

A-10 SPECTRUM ANALYZER

Log Scale: Within ± 2 dB linearity from -30 dBm to -90 dBm indication.

Dynamic Range: 70 dB (-30 dBm to -100 dBm).

Modes:	<u>SCAN WIDTH</u>	<u>BANDWIDTH</u>
	1 MHz/DIV	30 kHz
	500 kHz/DIV	30 kHz
	200 kHz/DIV	30 kHz
	100 kHz/DIV	30 kHz
	50 kHz/DIV	30 kHz
	20 kHz/DIV	3 kHz
	10 kHz/DIV	3 kHz
	5 kHz/DIV	3 kHz
	2 kHz/DIV	300 kHz
	1 kHz/DIV	300 kHz

The receiver is fixed on the center frequency for monitoring while the analyzer scans as specified.

A-11 MASTER OSCILLATOR

Standard TCXO:

Accuracy: 0.5 PPM (0-50° C)

Aging: 3 PPM first year, 1 PPM per year, thereafter.

Optional TCXO: (Option 01)

Accuracy: 0.2 PPM (0-50° C)

Aging: 3 PPM first year, 1 PPM per year, thereafter.

Optional Oven: (Option 02)

Accuracy: 0.05 PPM (0-50° C)

Aging: 0.25 PPM per year.

A-12 GENERATE AMPLIFIER (Optional)

Gain: 30 \pm 2 dB typical, 250 kHz to 1000 MHz
Test Set Output with
Amplifier Installed: Variable to +10 dBm, FM, CW
Variable to +4 dBm, AM

A-13 GENERAL CHARACTERISTICS

Dimensions: 13 1/16" wide, 7 5/16" high, 17½" deep
Weight: 32 lbs. (without options)
Temperature Range: 0 to 50° C

A-14 POWER REQUIREMENTS

Line: 105 - 130/210 - 260 VAC
50 - 400 Hz at 45 WATTS typical.
Ext. DC: 12 - 30 VDC nominal, 3 AMPS at 12 V
typical, 1.4 AMPS at 28 V typical

APPENDIX B - TEST EQUIPMENT REQUIREMENTS

B-1 GENERAL

This appendix contains a list of test equipment suitable for performing all of the maintenance procedures contained in this manual. Any other equipment meeting the specifications listed in this appendix may be substituted in place of the recommended models. It should be noted that the equipment listed in this appendix may exceed the minimum required specifications for some of the procedures contained in this manual.

B-2 RECOMMENDED TEST EQUIPMENT

TYPE	MANUFACTURER & MODEL	SPECIFICATIONS
Oscilloscope	Tektronix 465B	DC to 100 MHz 5 mV/div vertical trace 2 nS/div sweep rate Dual Trace
Spectrum Analyzer	Tektronix 7613 Frame Tektronix 7L13/U Spectrum Analyzer	Variable Persistence Storage Oscilloscope Frequency Range: 1 kHz to 2.5 GHz Resolution Bandwidth: 30 Hz to 3 MHz
Tracking Generator	Tektronix TM503 Frame	Three-wide Mainframe
	Tektronix TR502 Tracking Generator	Frequency Range: 100 kHz to 1.8 GHz Output Level: 0 dBm, ± 0.5 dB Power Range: 0 to -59 dBm in 10 and 1 dB steps
Frequency Counter	Fluke Model 7220A	Frequency Range: 5 Hz to 1300 MHz
Digital Multimeter	Fluke Model 8010A	3½ digit, $\pm 0.1\%$ basic DC accuracy
Distortion Analyzer	Sound Technology Model 1700B	Frequency Range: 10 Hz to 110 kHz Accuracy: .002% distortion AC Voltage Accuracy: 2%

TYPE	MANUFACTURER & MODEL	SPECIFICATIONS
Function Generator	Wavetek 182A	Frequency Range: .004 Hz to 4 MHz Functions: Sine, Triangle & Square High Level Output: 20 Vp-p (10 Vp-p into 50Ω)
Signal Generator	Hewlett Packard 8640B	Frequency Range: 1 to 1000 MHz Resolution: 0.1 to 100 Hz Accuracy: 2×10^{-6} RF Output: +20 to -130 dBm
Modulation Meter	Boonton Model 82AD	Frequency Range: 10 MHz to 1.2 GHz Accuracy: FM: ±2% of reading from 30 Hz to 100 kHz Accuracy: AM: ±2% of reading from 10 Hz to 90% AM and 5% of reading below 10% and above 90%; from 30 Hz to 100 kHz Resolution: 0.1% of full scale for FM and AM
RF Power Source	MCL 15122 Main Frame 6048 Oscillator Module	Frequency Range: 50 to 200 MHz Power Range: 0 to 65 W

TYPE	MANUFACTURER & MODEL	SPECIFICATIONS
RF Power Meter with Power Detector	Boonton RF Microwatt- meter Model 42 BD Boonton Power Sensor Model 41-4A	Frequency Range: 200 kHz to 18 GHz Power Range: 1.0 nW to 10 mW Accuracy: $\pm 0.25\%$ fs ± 0.15 dB >10 nW Frequency Range: 200 kHz to 7 GHz Power Range: 1 nW to 10 mW Accuracy: ± 0.3 dB >10 nW
Power Supply	B&K 1601	Regulation: .1% or 1 mV Ripple: 5 mV Voltage Range: 0-50 VDC @ 0-2 A

APPENDIX C - TABLE OF USER I/O PORTS/CONNECTOR PIN OUT TABLES

C-1 TABLE OF I/O PORTS

CONNECTOR NAME	CONNECTOR TYPE	SIGNAL INPUT/OUTPUT	SIGNAL TYPE
T/R	BNC	Input/Output	RF
AUX PWR	Banana Jack	Output	+12 VDC
DUPLEX Output	BNC	Output	RF
EXT MOD/SINAD	BNC	Input/Output	Audio
DEMODO	BNC	Output	Audio
TONE OUT	BNC	Output	Audio
MIC/ACC	5 Pin Microphone Connector	Input/Output	See Pin Out
SCOPE	BNC	Input	DC to 1 MHz
ANT	BNC	Input	RF
RS-232	25 Pin, Type D	Input/Output	See Pin Out
External Reference	BNC	Input/Output	10 MHz RF

C-2 PIN OUT TABLE FOR MIC/ACC CONNECTOR

MIC/ACC CONNECTOR PIN ASSIGNMENTS			
Pin No.	Signal Name	Signal Type	Input/Output
1	+12 VDC	DC Voltage	1/8 AMP Fused Output
2	Chassis GND		
3	Mic Key	Switched	GND for Generate
4	Mic Audio	Audio	Input
5	Tone Key	Switched	GND to Remove Variable Tone

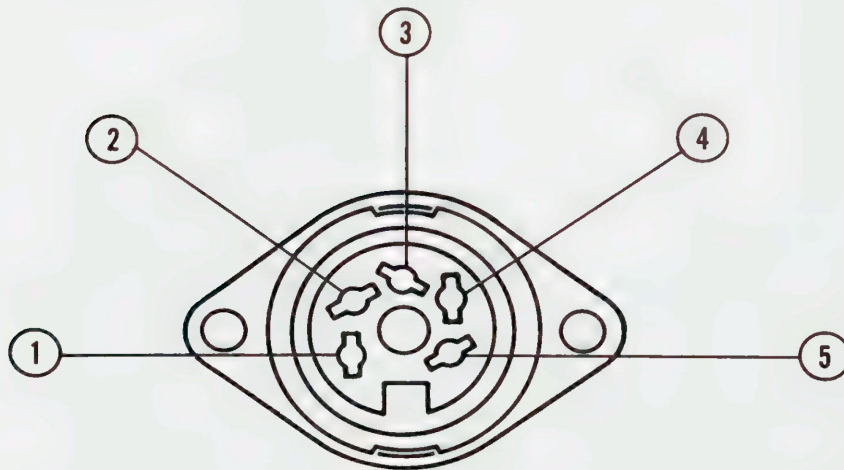

Figure C-1 MIC/ACC Connector Pin Identification (Front View)

C-3 PIN OUT TABLE FOR RS-232 CONNECTOR

RS-232 CONNECTOR PIN ASSIGNMENTS (The FM/AM-1200 is used as a terminal.)		
Pin No.	Input/Output	Remarks
2 (RXD)	← Commands	If low, FM/AM-1200 can receive command. If high FM/AM-1200 is busy.
3 (TXD)	Info →	
4 (RTS)	→	
5 (CTS)	←	
7 (Common Ground)		If low, terminal is not ready to receive. If not used, it must be tied high.
1, 6 and 8 thru 25 not used		

FM/AM-1200 PROTOCOL

No Parity

Must Be Half Duplex

Must Be Upper Case

8 Data Bits Per Character

Bit 8 Must Be Zero (Most Significant Bit)

1 Stop Bit (End Of Character)

High Level = -12V

Low Level = +12V

D-3 TUNE CONTROL POT

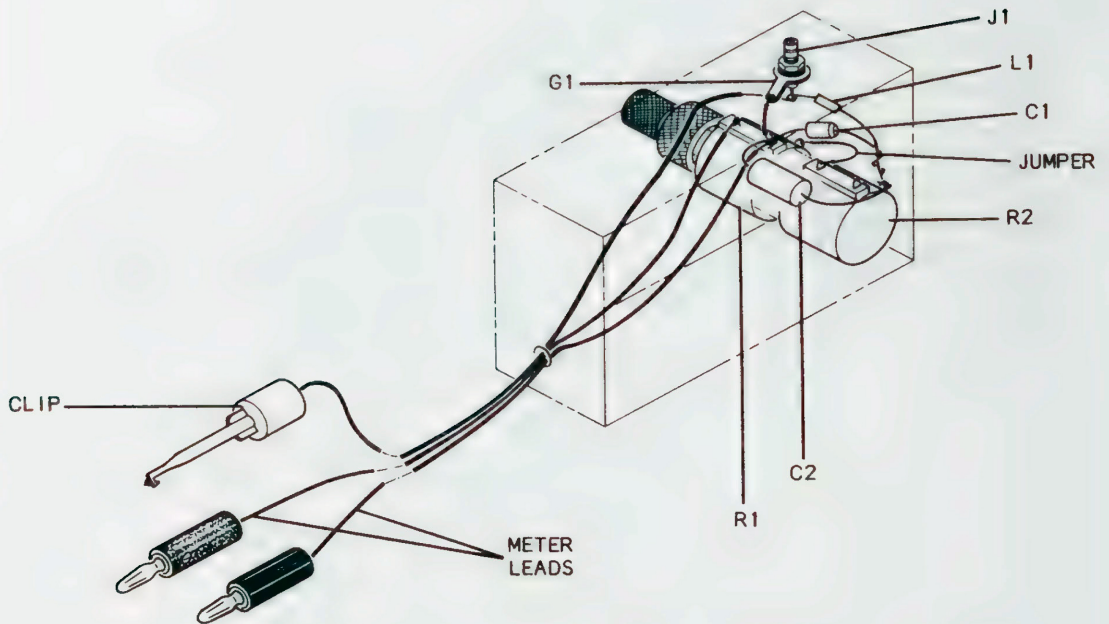
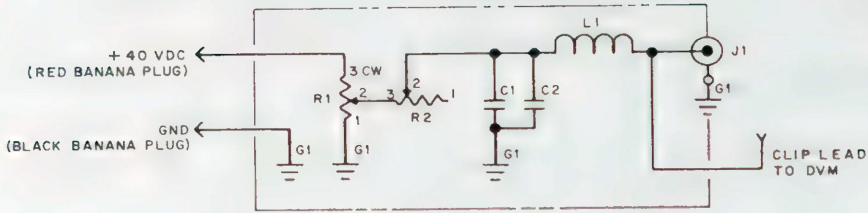

PART	TYPE	IFR PART NO.
R1, R2	10K, 10 TURN, 5%	4756-0000-001
C1	4.7 μ F, 35V TANT.	1502-0104-010
C2	0.1 μ F, 50V POLY CARB	1507-0475-018
L1	22 μ H	1801-0022-001
J1	SMB MALE	2123-0000-038
METER LEADS	ANY (RED & BLACK)	----
CLIP	ANY	----
CLIP LEAD	ANY	----
G1	GROUND LUG	----
KNOBS	ANY	----
ENCLOSURE	ANY	----

Figure D-2 Circuit Schematic and Diagram of Tune Control Pot

APPENDIX E - dBm TO MICROVOLT CONVERSION CHART

dBm	μV	dBm	μV	dBm	μV
0	224,000	-47	1,000	-94	4.47
-1	200,000	-48	891	-95	3.99
-2	178,000	-49	795	-96	3.55
-3	159,000	-50	709	-97	3.17
-4	141,000	-51	633	-98	2.82
-5	126,000	-52	563	-99	2.52
-6	112,000	-53	501	-100	2.24
-7	100,000	-54	447	-101	2.00
-8	89,100	-55	399	-102	1.78
-9	79,500	-56	355	-103	1.59
-10	70,900	-57	317	-104	1.41
-11	63,300	-58	282	-105	1.26
-12	56,300	-59	252	-106	1.12
-13	50,100	-60	224	-107	1.00
-14	44,700	-61	200	-108	0.891
-15	39,900	-62	178	-109	0.795
-16	35,500	-63	159	-110	0.709
-17	31,700	-64	141	-111	0.633
-18	28,200	-65	126	-112	0.563
-19	25,200	-66	112	-113	0.501
-20	22,400	-67	100	-114	0.447
-21	20,000	-68	89.1	-115	0.399
-22	17,800	-69	79.5	-116	0.355
-23	15,900	-70	70.9	-117	0.317
-24	14,100	-71	63.3	-118	0.282
-25	12,600	-72	56.3	-119	0.252
-26	11,200	-73	50.1	-120	0.224
-27	10,000	-74	44.7	-121	0.200
-28	8,900	-75	39.9	-122	0.178
-29	7,950	-76	35.5	-123	0.159
-30	7,090	-77	31.7	-124	0.141
-31	6,330	-78	28.2	-125	0.126
-32	5,630	-79	25.2	-126	0.112
-33	5,010	-80	22.4	-127	0.100
-34	4,470	-81	20.0	-128	0.0891
-35	3,990	-82	17.8	-129	0.0795
-36	3,550	-83	15.9	-130	0.0709
-37	3,170	-84	14.1	-131	0.0633
-38	2,820	-85	12.6	-132	0.0563
-39	2,520	-86	11.2	-133	0.0501
-40	2,240	-87	10.0	-134	0.0447
-41	2,000	-88	8.91	-135	0.0399
-42	1,780	-89	7.95	-136	0.0355
-43	1,590	-90	7.09	-137	0.0317
-44	1,410	-91	6.33	-138	0.0282
-45	1,260	-92	5.63	-139	0.0252
-46	1,120	-93	5.01	-140	0.0224

APPENDIX F - REPACKING FOR SHIPMENT

F-1 SHIPPING INFORMATION

IFR test sets returned to factory for calibration, service or repair must be repackaged and shipped subject to the following conditions:

Do not return any products to factory without first receiving authorization from IFR Customer Service Department.

CONTACT:

Customer Service Dept.
IFR, Inc.
10200 West York Street
Wichita, Kansas 67215

Telephone: (800)-835-2350
TWX: 910-741-6952

All test sets must be tagged with:

- a. Owner's identification and address.
- b. Nature of service or repair required.
- c. Model No.
- d. Serial No.

Sets must be repackaged in original shipping containers using IFR packing molds. If original shipping containers and materials are not available, contact IFR Customer Service Dept. for shipping instructions.

All freight costs on non-warranty shipments are assumed by customer. (See "Warranty Packet" for freight charge policy on warranty claims.)

F-2 REPACKING PROCEDURE (Reference - Figure F-1):

1. Make sure bottom packing mold is seated on floor of shipping container.
2. Carefully wrap test set with polyethylene sheeting to protect finish.
3. Place test set into shipping container, making sure set is securely seated in bottom packing mold.
4. Place top packing mold over top of set and press down until mold rests solidly on bottom packing mold.
5. Close shipping container lids and seal with shipping tape or an industrial stapler. Tie all sides of container with break resistant rope, twine or equivalent.

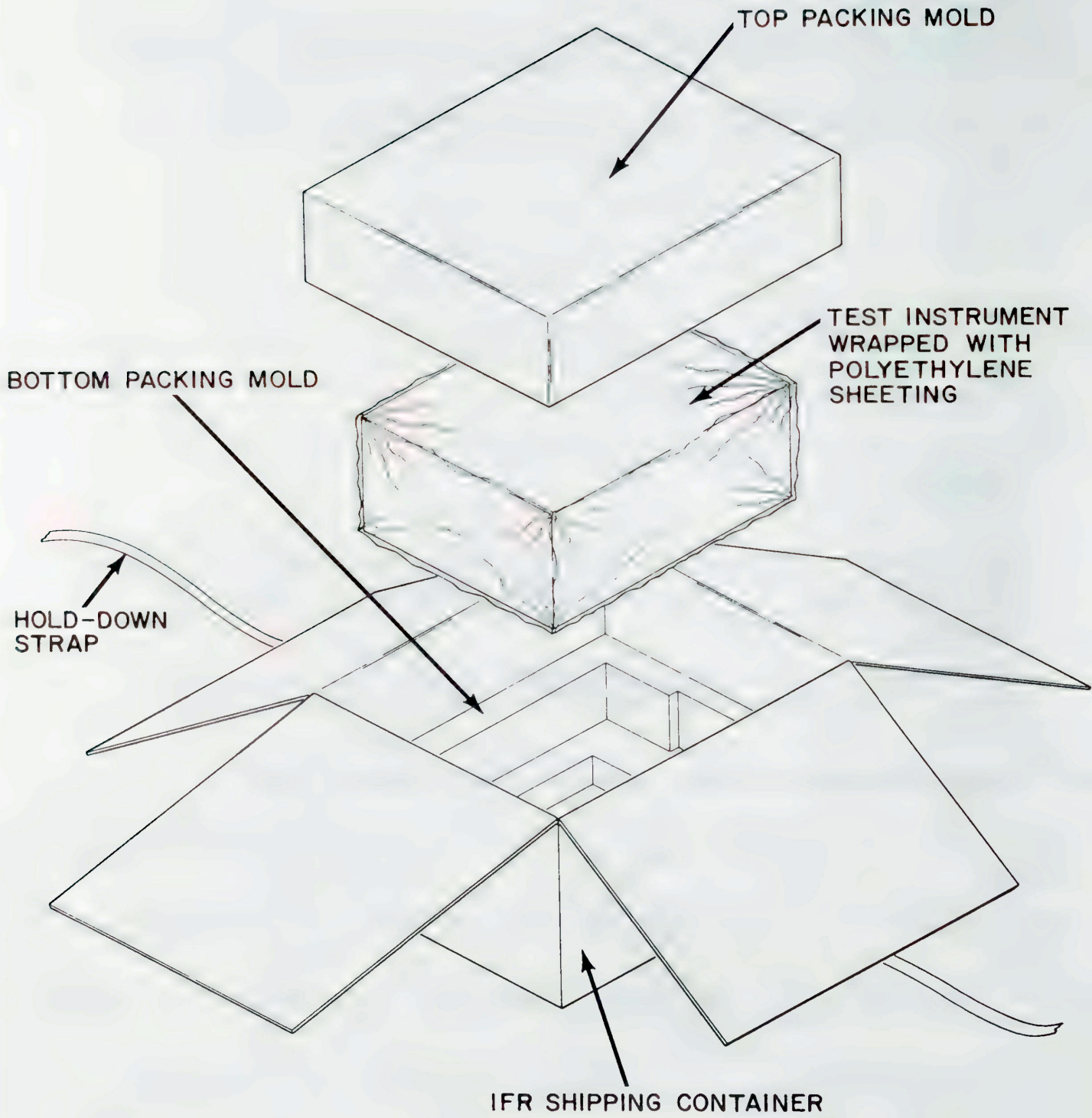

Figure F-1 Repacking for Shipment

APPENDIX G - ABBREVIATIONS & SYMBOLS

G-1 GENERAL

Defined below are various abbreviations and symbols which are commonly used throughout the FM/AM-1200 Maintenance Manual text.

G-2 GENERAL ABBREVIATIONS

A	- Ampere
AC or ac	- Alternating Current
Adj	- Adjustment
AGC	- Automatic Gain Control
AM	- Amplitude Modulation
Amp	- Ampere
ANALY DISP.	- Analyzer Dispersion
Assy	- Assembly
BATT	- Battery
BCD	- Binary Coded Decimal
BFO	- Beat Frequency Oscillator
°C	- Degrees Celsius
CAL	- Calibration
ccw	- Counterclockwise
CRT	- Cathode Ray Tube
cw	- Clockwise
CW	- Carrier Wave
DAC	- Digital to Analog Converter
dB	- decibels
dBc	- decibels above or below carrier level
dBm	- decibels above (or below) 1 milliwatt
DC or dc	- Direct Current
DCR	- Duty Cycle Regulator
DEFLEC AMP	- Deflection Amplifier
DEMODO	- Demodulation, demodulate or demodulated
DEV	- Deviation
DMM	- Digital Multimeter
DVM	- Digital Voltmeter
ECL	- Emitter Coupled Logic
EXT ACC	- External Accessory
EXT MOD	- External Modulation
EXT DC	- External Direct Current
°F	- Degrees Fahrenheit
FET	- Field Effect Transistor
FILT	- Filter
FM	- Frequency Modulation
FREQ	- Frequency
GEN	- Generate
GHz	- Gigahertz
GND	- Ground
HI LVL	- High Level
HORIZ	- Horizontal

Hz	- Hertz
IC	- Integrated Circuit
IF	- Intermediate Frequency
INT MOD	- Internal Modulation
IPC	- Illustrated Parts Catalog
Kg/cm ³	- Kilogram per cubic centimeter
kHz	- kilohertz
L/H	- Left-hand
LOG LIN	- Logarithmic Linearity
LO	- Local Oscillator
mA	- Milliamperes
MAX DISP	- Maximum Dispersion
Mech	- Mechanical
MHz	- Megahertz
MOD	- Modulation
MON	- Monitor
MTR	- Meter
μs	- microsecond
μV	- microvolt
ms or mSec	- millisecond
mV	- millivolt
mW	- milliwatt
MULT	- Multiplier
NC	- Not Connected
N/A	- Not Applicable
NORM	- Normal
OSC	- Oscillator
para	- paragraph
PC Bd	- Printed Circuit Board
PLL	- Phase Lock Loop
Preamp	- Preamplifier
psi	- pounds per square inch
PWR	- Power
PWR MON	- Power Monitor
RCVR	- Receiver
REF	- Reference
RF	- Radio Frequency
R/H	- Right-hand
RMS	- Root Mean Square
ROM	- Read Only Memory
sec	- Seconds
Scope Dev	- Oscilloscope Deviation
SIG	- Signal
SSB	- Single Sideband
SW	- Switch
TCXO	- Temperature Compensated Crystal Oscillator
TRANS	- Transmitter or Transceiver
TTL	- Transistor Transistor Logic
V	- Volts
Vp	- Volts Peak

Vp-p	- Volts Peak-to-Peak
VAC	- Volts Alternating Current
VCO	- Voltage Controlled Oscillator
VDC	- Volts Direct Current
VHF	- Very High Frequency
VOL	- Volume
VRMS	- Volts Root Mean Square
VSWR	- Voltage Standing Wave Ratio
W	- Watts
XMTR	- Transmitter
XTAL	- Crystal

G-3 ABBREVIATIONS FOR REFERENCE DESIGNATORS

BR	- Bridge Rectifier
C	- Capacitor
CR	- Diode
DS	- Display Lamps
E	- Terminal
FL	- Feed-thru Filter
G	- Ground
J	- Connector (Fixed)
K	- Relay
L	- Inductor
M	- Meter
MX	- Mixer
P	- Connector (Movable)
Q	- Transistor
R	- Resistor
SW	- Switch
T	- Transformer
TU	- Tuning Pole
U	- Integrated Circuit
VR	- Voltage Regulator
Y	- Crystal
YFL	- Crystal Filter

APPENDIX H - OPTIONAL GENERATE AMPLIFIER (OPTION 05)

H-1 GENERAL

The Generate Amplifier is a 30 dB amplifier intended to increase the output level of a generated signal above the normal maximum level by the service monitor. It is not designed to receive any signal directly from a Unit Under Test (UUT); however, if properly installed, it can be used to transmit and receive signals "off the air", using the antenna.

CAUTION

DO NOT TRANSMIT FROM A UUT DIRECTLY INTO THE GENERATE AMPLIFIER, OR THROUGH AN EXTERNAL ATTENUATOR. DAMAGE TO THE GENERATE AMPLIFIER AND/OR THE SERVICE MONITOR WILL RESULT.

H-2 INSTALLATION

Insert the banana plug on the Generate Amplifier into the AUX PWR Jack on the Front Panel of the Service Monitor and connect the BNC connector to the T/R Jack.

For Direct Connection To UUT:

Connect coax cable between the UUT Test Jack on the Generate Amplifier and the Microphone Jack or other audio input on the UUT.

For Radio Installation Checkout:

WARNING

THIS TEST MUST BE PERFORMED WITH THE SERVICE MONITOR AND UUT INSIDE A SHIELDED AREA TO PREVENT UNRESTRICTED RADIATION OF RF SIGNALS.

Connect coax between Antenna Jack on the Front Panel of the Service Monitor and the Antenna Jack on the Generate Amplifier. Connect accessory antenna to the UUT Test Jack on the Generate Amplifier.

H-3 OPERATION

Refer to FM/AM-1200 Operation Manual, Section 4 and perform the procedures for generating and receiving RF signals.

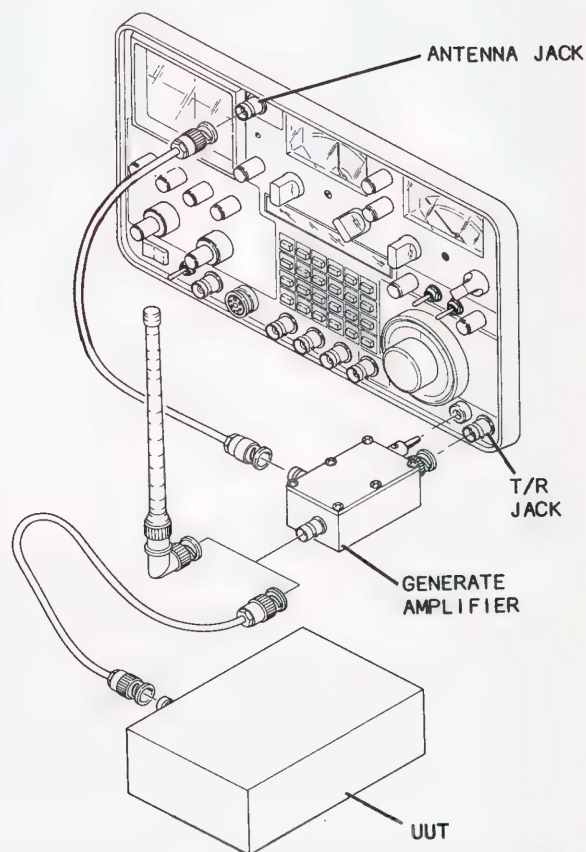

VERSION 1.4
EFF: S/N 3174

* NOTE: ASTERISK (*) BELOW, MARKS E-PROM LOCATION(S) EFFECTED BY THIS UPDATE.

E-PROM DATA:

1. PROCESSOR PC BD: 7010-6831-000
U12002: 3271-6801-140 (V-1.4)*
U12009: 3271-6802-140 (V-1.4)*
2. PULSE PC BD: 7010-6830-300
U11005: 3263-6800-240 (V-2.4)*
3. FRONT PANEL PC BD: 7010-6830-200
U14003: 3271-6803-140 (V-1.4)*

ENHANCEMENTS:

1. AN ON/OFF COMMAND WAS ADDED TO GP1B OPERATION.
2. VERSION NUMBER NOW DISPLAYED DURING INITIALIZATION.
3. ALTITUDE DISPLAY IS BLANK WHEN NO ALTITUDE IS REPORTED.
4. "NO REPLY" IS DISPLAYED ON LOWER HALF OF SCREEN, IF NO REPLY IS FOUND TO A SEQUENCE ITEM.

SYSTEM OPERATION MANUAL: 1002-6801-000
ILLUSTRATED PARTS LIST: 1002-6801-200
SYSTEM DATA - PACKAGE: 1007-6801-000

CORRECTIONS:

1. EXTRA INTERROGATIONS WERE BEING GENERATED IN ACL.
2. S-1403 WILL NOT OPERATE ABOVE SPECIFIED PRE LIMITS.
3. INCREASED ATC MODE PRE LIMIT TO 2400 PRE.
4. PERCENT REPLY NOW REPORTED FOR ATCRBS AND MODE-S IN BOTH ACL AND ACS MODES.
5. ELIMINATED SPURIOUS INTERROGATIONS EMITTED WHEN SWITCHING FUNCTIONS OR CHANGING CW/OFF/NORM SWITCH ON THE ATC-1400A.
6. BURST MODE DISPLAYS DATA FOR SEQ MODE, WHEN PRE IS <400. WITH PRE >400, DF DISPLAY IS NOW BLANK.
7. GP1B RANGE OF P4 IN ACL EXTENDED TO NOW COVER 0.2 TO 3.55 USEC. (UPPER LIMIT WAS 3.2 USEC)
8. IMPROVED GP1B RESPONSE TIME TO: PERCENT REPLY, REPLY DFLAY, DOWNLINK REQUESTS.
(RESPONSE TIME IS DEPENDENT ON PRE RATE + 150 MS DELAY - SEE GP1B PROGRAM TIMING, TABLE 1, S-1403 SERVICE BULLETIN #5)

FM/AM-1200 A/S
FIRMWARE REVISION OUTLINE

<u>FIRMWARE REVISION</u>	<u>EFFECTIVE SERIAL NO.</u>	<u>PAGE</u>
PROCESSOR PC BOARD ASSEMBLY . . .	(8-BIT) . . .	1
1.7	1558 . . . (8-BIT) . . .	2
1.1	1250A/3200S	2
1.2	1250A/3200S	2
1.4	1250A/3200S	2A
1.5	1250A/3200S	2A
1.51	1250A/3200S	2A
PROCESSOR PC BOARD ASSEMBLY . . .	(16-BIT) . . .	3
OPTION-11 ENC/DEC PC BD. ASSY		3A
1.3	OPTION-11	3B
2.0	N/A	4
2.2	1449A/4491S . . . (16-BIT) . . .	4
2.3	N/A	4
2.4	4762S	4
2.5	1467A/4878S	5
3.0	1697A	5
3.0	5031S	5
FIRMWARE SUFFIX NUMBERS		6
ENHANCED OPT-11 PC BD		6A
ENHANCED OPT-11 PC BD + S.B.-05		6A1
CELLULAR / E-TACS PC BD		6A2
2.3	ENH OPT-11	6B
3.0ENH OPT-11, OPT-15	6B
3.1ENH OPT-11, OPT-15	6B
* 3.2	OPT-15	6B

* = CURRENT CHANGES

(7/90)

FM/AM-1200 A/S
FIRMWARE REVISION OUTLINE

<u>FIRMWARE REVISION</u>	<u>EFFECTIVE SERIAL NO.</u>	<u>PAGE</u>
4.00 . . . ENH OPT-11, OPT-15, OPT-16 . . .		6C
4.01 . . . ENH OPT-11, OPT-15, OPT-16 . . .		6C
5.2-XX 6330S		7
5.3-XX 6815S		8
6.0-XX 7847S		9
PROCESSOR PC BOARD ASSY. (16-BIT) .		10
6.1-XX 8617S		11
7.0-XX 10556S		12

* = CURRENT CHANGES

(7/90)

VERSION LEVEL AND EFFECTIVITY	ENHANCEMENTS	CORRECTIONS
<p>VERSION 2.2 EFF: S/N 6330(S) E-PROM DATA ENC/DEC ASSY, U7: P/N 3271-7730-220</p>	<p>1. ADDS TWO FORMATS: CCIRH (20 MSEC), AND CCIRH4 (40 MSEC). 2. ALL FORMATS NOW ACCEPT 8 DIGITS ON VFD DISPLAY. 3. 5/6 TONE FORMAT NOW ACCEPTS PREAMBLE TONE. 4. DEVIATION SET NOW PROGRAMMABLE TO 7.0 KHZ. 5. "G" CHARACTER AVAILABLE TO DESIGNATE TONE "GROUPS" (OPERATORS MANUAL UPDATE: 1002-5501-007)</p>	<p>1. "ENHANCEMENTS" ACCESSABLE WITH FIRMWARE VER 5.2-XX AND UP. 2. WILL OPERATE IDENTICAL TO ORIGINAL OPT-11 IF INSTALLED IN FM1200, VER 3.0. 3. REFERENCE PAGE 6A FOR E-PROM U7 LOCATION. 4. "ENHANCED" OPTION-11 IS PART OF OPTION-15. 5. ORIGINAL OPTION-11 CANNOT BE UPGRADED.</p>
<p>VERSION 2.3 EFF: S/N 6956(S) E-PROM DATA ENC/DEC ASSY, U7: P/N 3271-7703-230</p>	<p>NONE (OPERATORS MANUAL UPDATE: NONE REQUIRED)</p>	<p>1. DECODING FEATURE WAS INTERMITTENT.</p>
<p>VERSION 3.0 EFF: S/N 7847(S) E-PROM DATA ENC/DEC ASSY, U7: P/N 3271-7703-300</p>	<p>NONE (OPERATORS MANUAL UPDATE: NONE REQUIRED)</p>	<p>1. OCCASIONALLY ON POWER-UP, U22 WOULD NOT LOAD PROGRAM. 2. REFERENCE FM1200S/A S.B.-05 FOR HARDWARE CHANGES.</p>
<p>VERSION 3.1 EFF: S/N 8617(S) E-PROM DATA ENC/DEC ASSY, U7: P/N 3271-7703-310</p>	<p>1. RS-232 COMMANDS ADDED. 2. "A" "B" "C" "D" CHARACTERS NOW VALID DIGITS IN ALL FORMAT SEQUENCES. (OPERATORS MANUAL UPDATE: 1002-5501-008)</p>	<p>1. INCOMPATIBLE WITH SOME LOW COST HAND-HELD AND MOBILE CELLULAR TELEPHONES. NOTE: OPTIONS 11/15 MUST HAVE VER 6.1-XX INSTALLED FOR THIS VERSION.</p>
<p>VERSION 3.2 EFF: S/N N/A E-PROM DATA ENC/DEC ASSY, U7: P/N 3271-7703-311</p>	<p>NONE (OPERATORS MANUAL UPDATE: NONE REQUIRED)</p>	<p>1. CELLULAR VOICE CHANNEL NO LONGER DROPS OUT WHEN TESTING FUJITSU FX CELLULAR TELEPHONE. 2. VER 3.2 IS IDENTICAL TO ENGINEERING PROTOTYPE VER 3.1.1 FIELDLED FOR VERIFICATION. 3. THIS CORRECTION IS INCLUDED IN VER 4.0 AND ABOVE.</p>
<p>FM/AM-1200S</p>	<p>FIRMWARE REVISION OUTLINE (CELLULAR, OPTION-15)</p>	<p>("ENHANCED" OPTION-11) (E-TACS, OPTION-16) PAGE NO. 6B</p>

VERSION LEVEL AND EFFECTIVITY	ENHANCEMENTS	CORRECTIONS
<p>VERSION 4.00 EFF: S/N 10556S E-FROM DATA: ENC/DEC ASSY, U7: 3271-7703-400</p>	<p>1. ENABLED EUROPEAN TONE TO ENCODE UP TO 8 TONES, INSTEAD OF 5 TONES PER STANDARD SPEC. 2. AUSTRALIAN TWO-TONE PERIOD GAP AFTER FIFTH TONE NOW ENABLED ONLY FOR CCIRH AND CCIRH4. EURO-CODES DO NOT INCORPORATE A TONE GAP AT THIS TIME. 3. ADDS "THRULINE" POWER METER MODULE TO OPT-15/16. (OPERATORS MANUAL UPDATE: 1002-5501-000, REV 06)</p>	<p>1. CHANGED DURATION FROM ONE TONE-GAP TO TWO TONE-GAPS FOR CCIRH AND CCIRH4. (OPT-11) 2. CELLULAR / E-TACS PRINTOUT: A. FROM: 1200S/A, TO: 1200S. B. FROM: TACS, TO: E-TACS. 3. "THRULINE" MODULE P/N: 7005-7740-600. 4. THIS IS NOT A WARRANTY UPDATE - SEE PG. 12.</p>
<p>VERSION 4.01 EFF: S/N 10556S E-FROM DATA: ENC/DEC ASSY, U7: 3271-7703-401</p>	<p>(OPERATORS MANUAL UPDATE: 1002-5501-009)</p>	<p>1. FM1200S WATT METER NOW USED TO MEASURE TYPE 1 PHONE POWER LEVEL 0 (7 WATTS). 2. 75 MS DELAY NOW 300 MS DELAY, AFTER SAT TONE "TURN-OFF" COMMAND. 3. ABOVE CHANGES FOR E-TACS OPTION-16, ONLY.</p>

FM/AM-1200 A/S
FIRMWARE REVISION OUTLINE

FIRMWARE REVISION	EFFECTIVE SERIAL NO.	PAGE
PROCESSOR PC BOARD ASSEMBLY	(8-BIT)	1
1.7	1558 (8-BIT)	2
1.1	1250A/3200S	2
1.2	1250A/3200S	2
1.4	1250A/3200S	2A
1.5	1250A/3200S	2A
1.51	1250A/3200S	2A
PROCESSOR PC BOARD ASSEMBLY	(16-BIT)	3
OPTION-11 ENC/DEC PC BD. ASSY		3A
1.3	OPTION-11	3B
2.0	N/A	4
2.2	1449A/4491S (16-BIT)	4
2.3	N/A	4
2.4	4762S	4
2.5	1467A/4878S	5
3.0	1697A	5
3.0	5031S	5
FIRMWARE SUFFIX NUMBERS		6
ENHANCED OPT-11 PC BD		6A
ENHANCED OPT-11 PC BD + S.B.-05		6A1
CELLULAR / E-TACS PC BD		6A2
2.3	ENH OPT-11	6B
3.0	ENH OPT-11, OPT-15	6B
3.1	ENH OPT-11, OPT-15	6B
* 3.2	OPT-15	6B

* = CURRENT CHANGES

(7/90)

FM/AM-1200 A/S
FIRMWARE REVISION OUTLINE

<u>FIRMWARE REVISION</u>	<u>EFFECTIVE SERIAL NO.</u>	<u>PAGE</u>
4.00 . . .	ENH OPT-11, OPT-15, OPT-16 . . .	6C
4.01 . . .	ENH OPT-11, OPT-15, OPT-16 . . .	6C
5.2-XX	6330S	7
5.3-XX	6815S	8
6.0-XX	7847S	9
PROCESSOR PC BOARD ASSY.	(16-BIT)	10
6.1-XX	8617S	11
7.0-XX	10556S	12

VERSION LEVEL AND EFFECTIVITY	ENHANCEMENTS	CORRECTIONS
VERSION 2.2 EFF: S/N 6330(S) E-PROM DATA ENC/DEC ASSY, U7: P/N 3271-7730-220	1. ADDS TWO FORMATS: CCIRH (20 MSEC), AND CCIRH4 (40 MSEC). 2. ALL FORMATS NOW ACCEPT 8 DIGITS ON VFD DISPLAY. 3. 5/6 TONE FORMAT NOW ACCEPTS PREAMBLE TONE. 4. DEVIATION SET NOW PROGRAMMABLE TO 7.0 KHZ. 5. "G" CHARACTER AVAILABLE TO DESIGNATE TONE "GROUPS" (OPERATORS MANUAL UPDATE: 1002-5501-007) NONE (OPERATORS MANUAL UPDATE: NONE REQUIRED)	1. "ENHANCEMENTS" ACCESSABLE WITH FIRMWARE VER 5.2-XX AND UP. 2. WILL OPERATE IDENTICAL TO ORIGINAL OPT-11 IF INSTALLED IN FM1200, VER 3.0. 3. REFERENCE PAGE 6A FOR E-PROM U7 LOCATION. 4. "ENHANCED" OPTION-11 IS PART OF OPTION-15. 5. ORIGINAL OPTION-11 CANNOT BE UPGRADED. 1. DECODING FEATURE WAS INTERMITTENT.
VERSION 2.3 EFF: S/N 6956(S) E-PROM DATA ENC/DEC ASSY, U7: P/N 3271-7703-230	NONE (OPERATORS MANUAL UPDATE: NONE REQUIRED)	1. OCCASIONALLY ON POWER-UP, U22 WOULD NOT LOAD PROGRAM. 2. REFERENCE FM1200S/A S.B.-05 FOR HARDWARE CHANGES.
VERSION 3.0 EFF: S/N 7847(S) E-PROM DATA ENC/DEC ASSY, U7: P/N 3271-7703-300	NONE (OPERATORS MANUAL UPDATE: NONE REQUIRED)	1. INCOMPATIBLE WITH SOME LOW COST HAND-HELD AND MOBILE CELLULAR TELEPHONES. NOTE: OPTIONS 11/15 MUST HAVE VER 6.1-XX INSTALLED FOR THIS VERSION.
VERSION 3.1 EFF: S/N 8617(S) E-PROM DATA ENC/DEC ASSY, U7: P/N 3271-7703-310	1. RS-232 COMMANDS ADDED. 2. "A" "B" "C" "D" CHARACTERS NOW VALID DIGITS IN ALL FORMAT SEQUENCES. (OPERATORS MANUAL UPDATE: 1002-5501-008)	1. CELLULAR VOICE CHANNEL NO LONGER DROPS OUT WHEN TESTING FUJITSU FX CELLULAR TELEPHONE. 2. VER 3.2 IS IDENTICAL TO ENGINEERING PROTOTYPE VER 3.1.1 FIELDIED FOR VERIFICATION. 3. THIS CORRECTION IS INCLUDED IN VER 4.0 AND ABOVE.
VERSION 3.2 EFF: S/N N/A E-PROM DATA ENC/DEC ASSY, U7: P/N 3271-7703-311	NONE (OPERATORS MANUAL UPDATE: NONE REQUIRED)	("ENHANCED" OPTION-11) (E-TACS, OPTION-16) (CELLULAR, OPTION-15)

VERSION LEVEL AND EFFECTIVITY	ENHANCEMENTS	CORRECTIONS
VERSION 4.00 EFF: S/N 10556S E-FROM DATA: ENC/DEC ASSY, U7: 3271-7703-400	1. ENABLED EUROPEAN TONE TO ENCODE UP TO 8 TONES, INSTEAD OF 5 TONES PER STANDARD SPEC. 2. AUSTRALIAN TWO-TONE PERIOD GAP AFTER FIFTH TONE NOW ENABLED ONLY FOR CCIRH AND CCIRH4. EURO-CODES DO NOT INCORPORATE A TONE GAP AT THIS TIME. 3. ADDS "THRULINE" POWER METER MODULE TO OPT-15/16. (OPERATORS MANUAL UPDATE: 1002-5501-000, REV 06)	1. CHANGED DURATION FROM ONE TONE-GAP TO TWO TONE-GAPS FOR CCIRH AND CCIRH4. (OPT-11) 2. CELLULAR / E-TACS PRINTOUT: A. FROM: 1200S/A, TO: 1200S. B. FROM: TACS, TO: E-TACS. 3. "THRULINE" MODULE F/N: 7005-7740-600. 4. THIS IS NOT A WARRANTY UPDATE - SEE PG. 12.
VERSION 4.01 EFF: S/N 10556S E-FROM DATA: ENC/DEC ASSY, U7: 3271-7703-401	(OPERATORS MANUAL UPDATE: 1002-5501-009)	1. FM1200S WATT METER NOW USED TO MEASURE TYPE 1 PHONE POWER LEVEL 0 (7 WATTS). 2. 75 MS DELAY NOW 300 MS DELAY, AFTER SAT TONE "TURN-OFF" COMMAND. 3. ABOVE CHANGES FOR E-TACS OPTION-16, ONLY.

