

COAX NO.	SIGNAL SOURCE		SIGNAL DESTINATION		RECEIVE MODE		GENERATE MODE		DUPLEX MODE	
	CONNECTOR NO.	MODULE	CONNECTOR NO.	MODULE	LEVEL	FREQ/SIGNAL	LEVEL	FREQ/SIGNAL	LEVEL	FREQ/SIGNAL
1	J4202	LOW LOOP	J2203	IF BLOCK	+5 TO +12 dBm	77.3-79.3 MHz	+5 TO +12 dBm	77.3-79.3 MHz	+5 TO +12 dBm	77.3-79.3 MHz
2	J4203	LOW LOOP	J403	ANALYZER RF	-20 TO -40 dBm	77.3-79.3 MHz	-20 TO -40 dBm	77.3-79.3 MHz	-20 TO -40 dBm	77.3-79.3 MHz
3	J602	HI/LOW FILTER	J4101	HIGH LOOP	-28 dBm TO -34 dBm	90-1088 MHz	-28 dBm TO -34 dBm	90-1088 MHz	-28 dBm TO -34 dBm	90-1088 MHz
4	E2807	FREQ STANDARD	J4001	HIGH LOOP	4 V P-P (±.5 V)	500 KHz	4 V P-P (±.5 V)	500 KHz	4 V P-P (±.5 V)	500 KHz
5	J4103	HIGH LOOP	J1201	DUPLEX	-20 TO -30 dBm	90-1088 MHz	-20 TO -30 dBm	90-1088 MHz	-20 TO -30 dBm	90-1088 MHz
6	J4003	HIGH LOOP	J1906	DUAL VCO (1ST LO)	D.C.	0-35 VDC	D.C.	0-35 VDC	D.C.	0-35 VDC
7	J4002	HIGH LOOP	J1903	DUAL VCO (2ND LO)	D.C.	0 VDC	D.C.	0 VDC	D.C.	0 VDC
8	J1203	DUPLEX	J3513	DUPLEX CONNECTOR					-60 dBm	OFFSET GEN FREQ
9	J1204	DUPLEX	J5105	OUTPUT AMPLIFIER					-30 dBm	OFFSET GEN FREQ
10	J4303	10.7 MHz GEN/REC	J4401	DIGITAL	120 mV P-P (±10 mV)	10.7 MHz	120 mV P-P (±10 mV)	10.7 MHz	120 mV P-P (±10 mV)	10.7 MHz
11	J4304	10.7 MHz GEN/REC	J4502	DIGITAL	2.2 V P-P (±.2 mV)	21.4 MHz	2.2 V P-P (±.2 mV)	21.4 MHz	2.2 V P-P (±.2 mV)	21.4 MHz
12	E2806	FREQ STANDARD	J4503	DIGITAL	4.0 V P-P (±.5 V)	1 MHz	4.0 V P-P (±.5 V)	1 MHz	4.0 V P-P (±.5 V)	1 MHz
13	J2202	IF BLOCK	J4302	10.7 MHz GEN/REC	INPUT ±2 dBm	10.7 MHz	-15 TO -20 dBm	10.7 MHz	INPUT ±2 dBm	10.7 MHz
14	J405	ANALYZER RF	J2208	IF BLOCK	INPUT	83-95 MHz	-28 dBm TO -32 dBm	88-90 MHz	INPUT	83-95 MHz
15	E2809	FREQ STANDARD	J404	ANALYZER RF	1.5 V P-P (±.2 V)	1 MHz	1.5 V P-P (±.2 V)	1 MHz	1.5 V P-P (±.2 V)	1 MHz
16	J401	ANALYZER RF	J502	ANALYZER IF	0 TO 5 dBc	22.3 MHz	-45 TO -60 dBc	22.3 MHz	0 TO 5 dBc	22.3 MHz
17	J503	ANALYZER IF	J802	ANALYZER LOG AMP	30 dBc	1.2 MHz	30 dBc	1.2 MHz	30 dBc	1.2 MHz
18	J3512	ANT CONNECTOR	J2201	IF BLOCK	INPUT	RF			INPUT	RF
19	J2202	IF BLOCK	J1501	OUTPUT AMPLIFIER			-20 dBm (±5 dB)	RF		
20	J5103	OUTPUT AMPLIFIER	AT3501-J1	ATTENUATOR			W/FINE ATTN CCW 0 dBm (±1 dB)	RF		
21	AT3501-J2	ATTENUATOR	J5102	OUTPUT AMPLIFIER			20 dB ABOVE SELECTED LEVEL	RF		
22	J3514	T/R CONNECTOR	J5104	OUTPUT AMPLIFIER			-20 TO -127 dBm	RF	-80 dBm	RF
23	J2209	IF BLOCK	J406	ANALYZER RF	INPUT	83-95 MHz	-28 dBm TO -32 dBm	88-90 MHz	INPUT	83-95 MHz
24	J6402	LOW PASS FILTER	J601	HI/LOW FILTER	-25 dBm TO -30 dBm	90-1088 MHz	-25 dBm TO -30 dBm	90-1088 MHz	-25 dBm TO -3 dBm	90-1088 MHz
25	J1907	DUAL VCO	J6401	LOW PASS FILTER	-22 dBm TO -28 dBm	90-1088 MHz	-22 dBm TO -28 dBm	90-1088 MHz	-22 dBm TO -28 dBm	90-1088 MHz
26	J1905	DUAL VCO	J9301	MIXER NULL	+5 TO +12 dBm	1300-2298 MHz	+5 TO +12 dBm	1300-2298 MHz	+5 TO +12 dBm	1300-2298 MHz
27	J1902	DUAL VCO	J2207	IF BLOCK	+5 TO +12 dBm	1210 MHz	+5 TO +12 dBm	1210 MHz	+5 TO +12 dBm	1210 MHz
28	E2805	FREQ STANDARD	J4603	EXT REF CONNECTOR	130 mV P-P (±10 mV)	10 MHz	130 mV P-P (±10 mV)	10 MHz	130 mV P-P (±10 mV)	10 MHz
29	J3602	OPT OVEN OSC	E2808	FREQ STANDARD	1.5 V P-P (±.2 V)	10 MHz	1.5 V P-P (±.2 V)	10 MHz	1.5 V P-P (±.2 V)	10 MHz
30	J9302	MIXER NULL	J2205	IF BLOCK	+5 TO +12 dBm	1300-2298 MHz	+5 TO +12 dBm	1300-2298 MHz	+5 TO +12 dBm	1300-2298 MHz
31	J9303	MIXER NULL	J2210	IF BLOCK		1300-2298 MHz		1300-2298 MHz		1300-2298 MHz

Figure 7-1 FM/AM-1200 System Block Diagram With Coax Numbers And Signal Flow Data

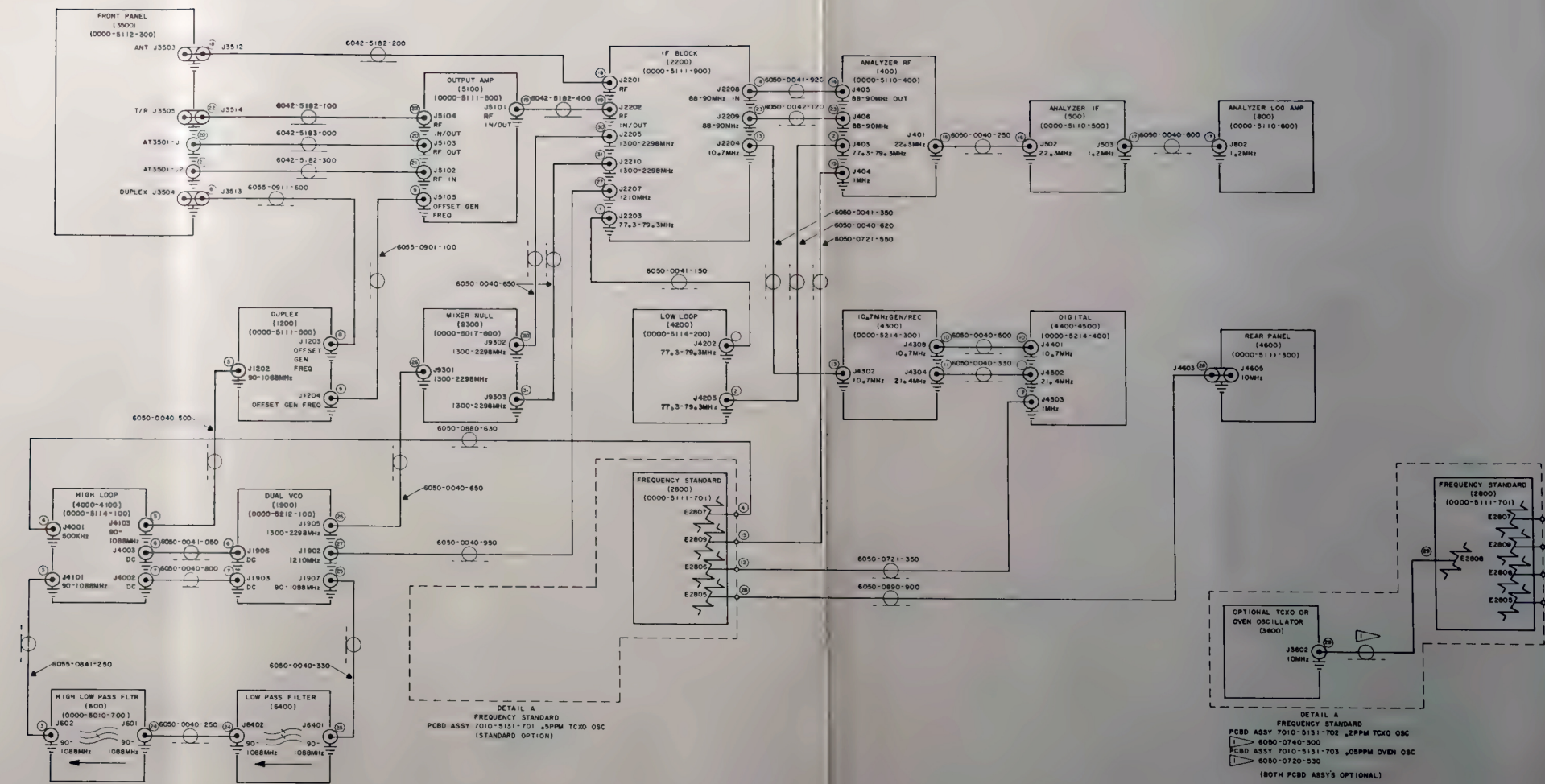
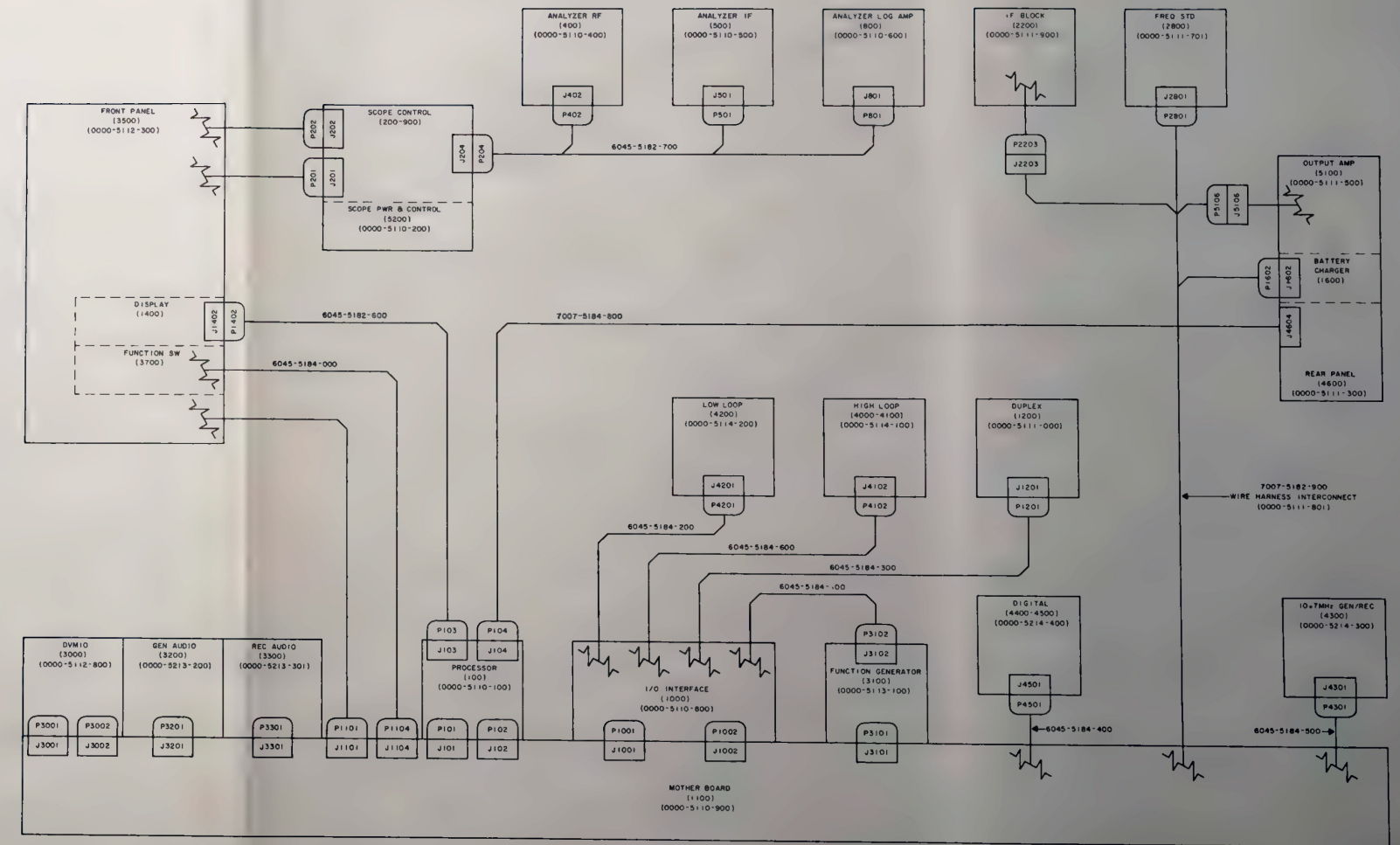

Figure 7-2 Coaxial Cable Interconnect Diagram (0000-5111-800-G)



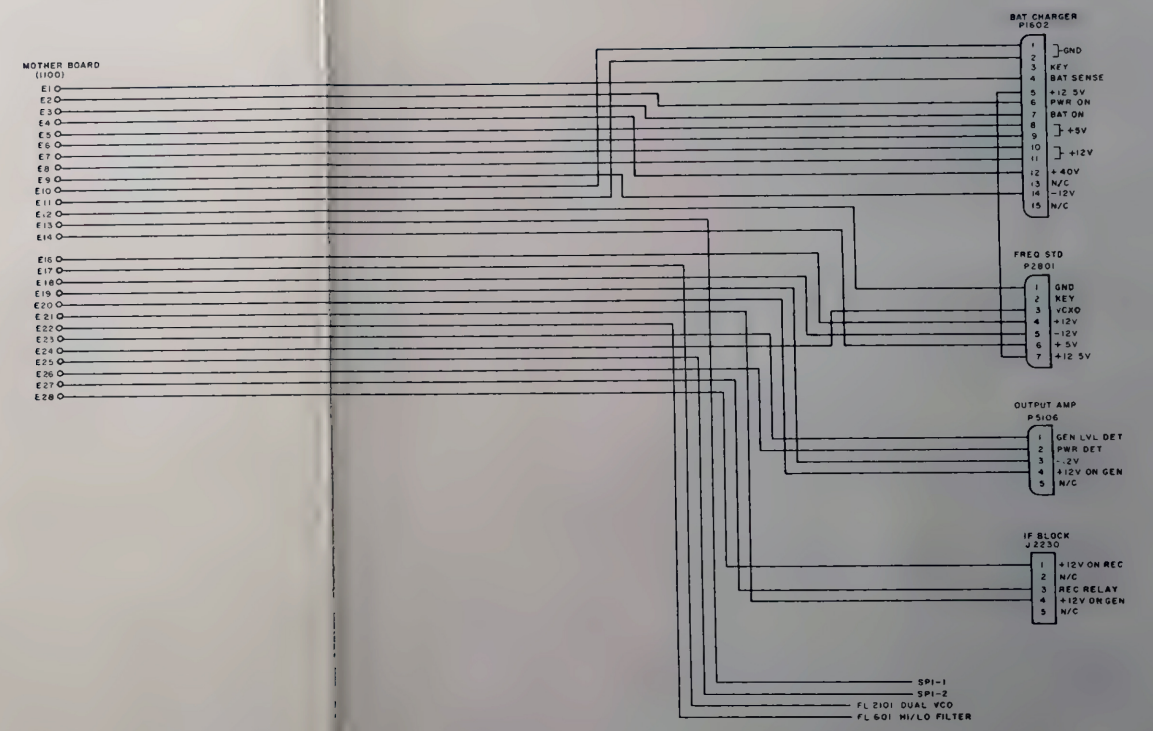
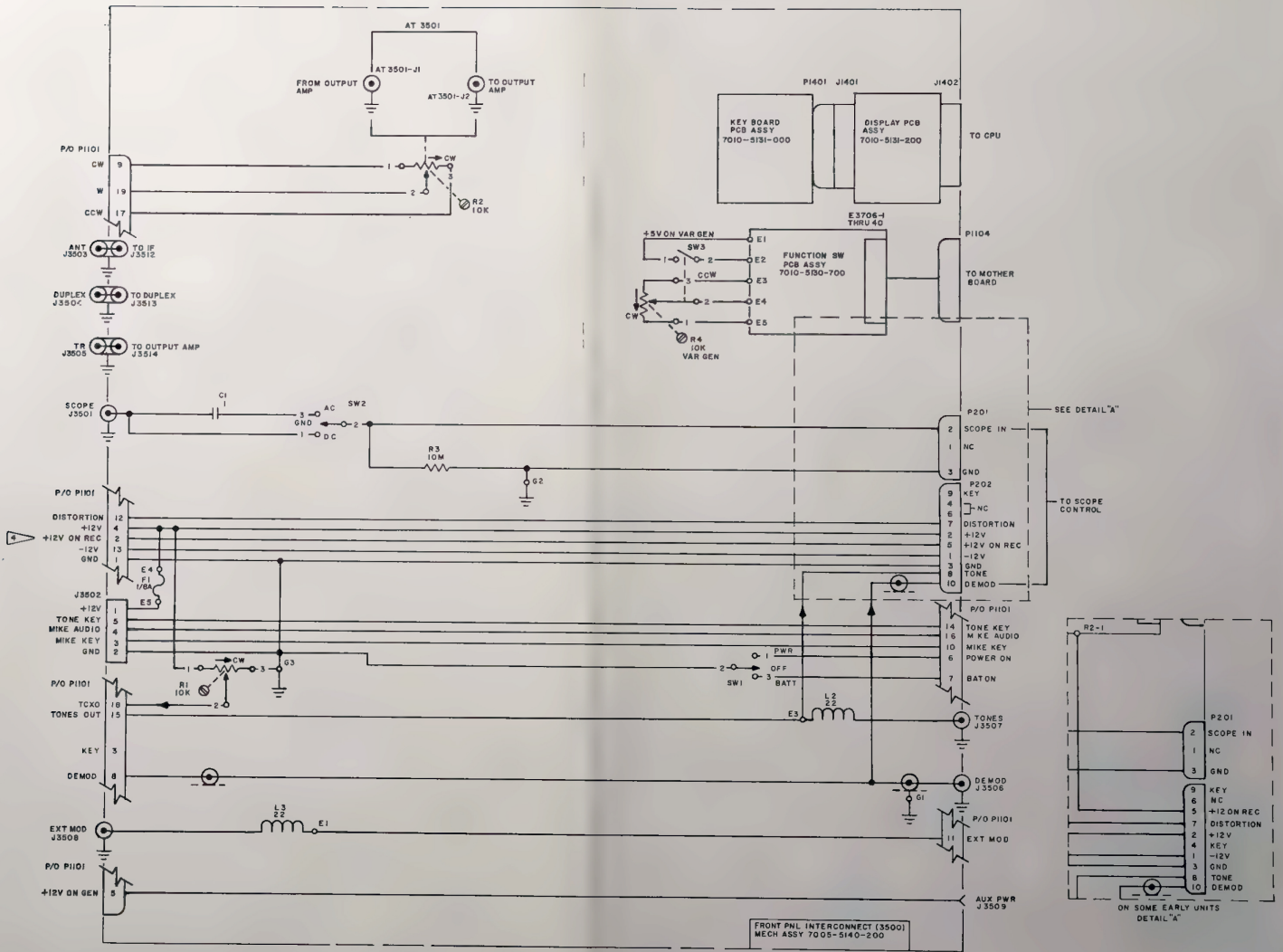
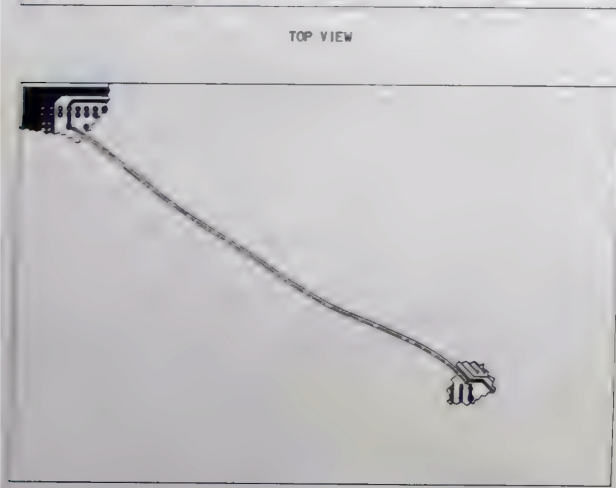
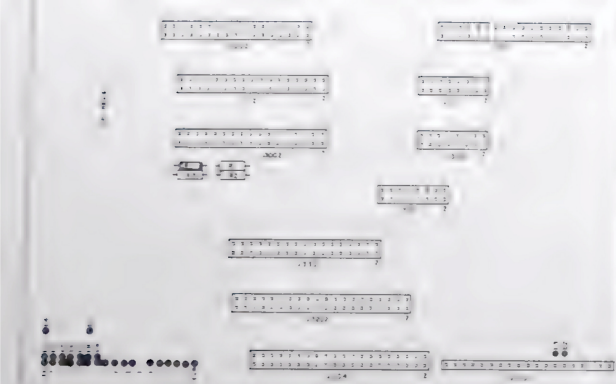

Figure 7-4 Main Wire Harness Diagram (0000-5111-801)



- NOTES:
1. ALL REFERENCE NUMBERS CARRY ASSIGNED DESIGNATOR SERIES. THIS SCHEMATIC CARRIES 3500 (E.G., R1 IS R3501).
  2. ALL RESISTORS ARE 1/4 W, 5% TOLERANCE UNLESS OTHERWISE NOTED.
  3. ALL RESISTANCE IS EXPRESSED IN OHMS UNLESS OTHERWISE NOTED.
  4. P1101 - PIN 2 ON SOME EARLY UNIT WAS NC.
  5. ALL CAPACITANCE IS EXPRESSED IN MICROFARADS UNLESS OTHERWISE NOTED.
  6. ALL INDUCTANCE IS EXPRESSED IN MICROHENRYS UNLESS OTHERWISE NOTED.

Figure 7-5 Front Panel Interconnect Diagram (0000-5112-300-H)



- NOTES:
1. ALL REFERENCE NUMBERS CARRY ASSIGNED DESIGNATOR SERIES. THIS SCHEMATIC CARRIES SERIES 1100 (E.G., R1 IS R1101).
  2. ALL RESISTORS ARE 1/4 W, 5% TOLERANCE UNLESS OTHERWISE NOTED.
  3. ALL RESISTANCE IS EXPRESSED IN OHMS UNLESS OTHERWISE NOTED.

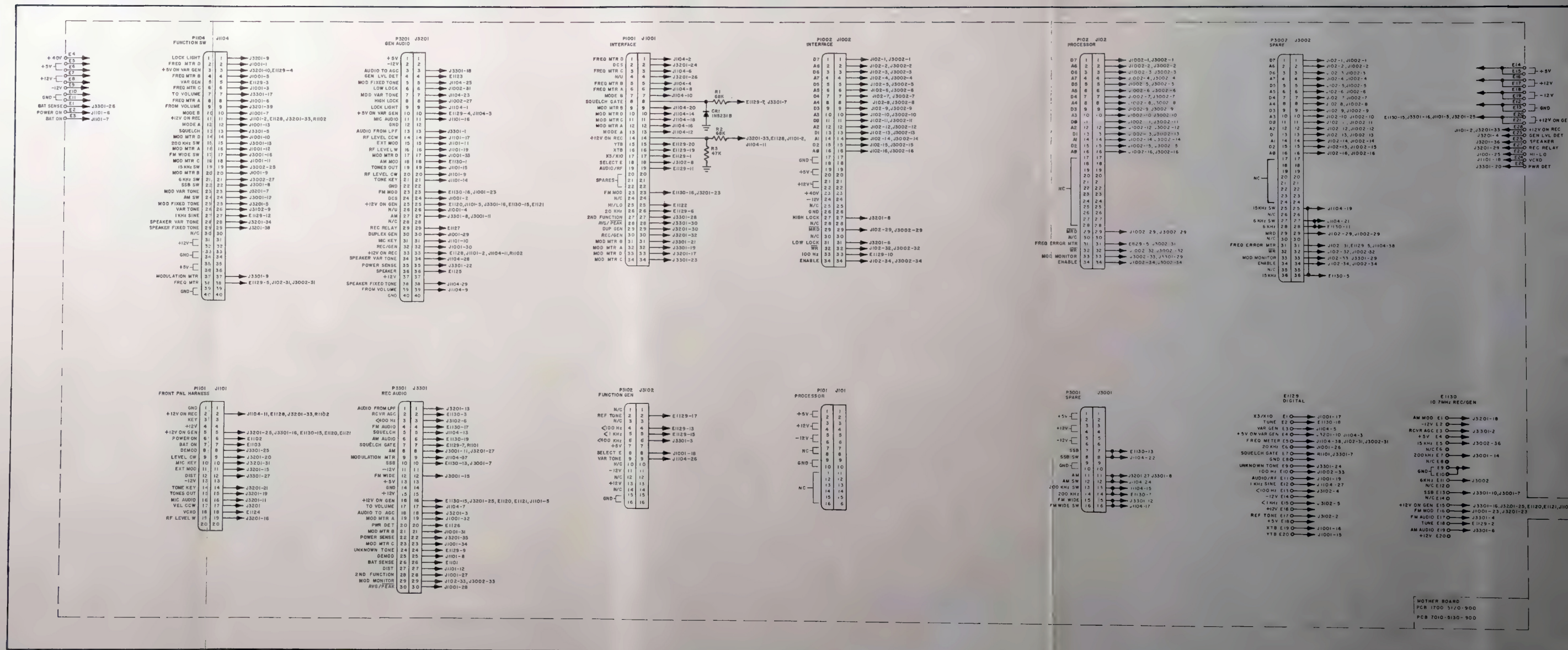
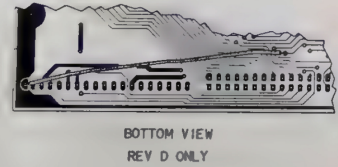

Motherboard PC Board (Rev E-3)

Figure 7-6 Motherboard PC Board Assembly (0000-5110-900-E3)





**STANDARDS:**  
(UNLESS OTHERWISE NOTED)

1. ALL REFERENCE NUMBERS CARRY ASSIGNED DESIGNATOR SERIES. THIS SCHEMATIC CARRIES SERIES:

- A. 1500 (INVERTER SUPPLY PC BOARD).
- B. 1600 (BATTERY CHARGER PC BOARD).
- C. 1700 (LINE SUPPLY PC BOARD).
- D. 3900 (POWER SUPPLY MECH ASSY).
- E. 4600 (REAR PANEL MECH ASSY).
- F. (E.g., R1 IS R1501, ETC.)

2. ALL RESISTORS ARE 1/4 W, 5% TOLERANCE. PRECISION RESISTORS (1%) ARE DESIGNATED BY AN ASTERISK (\*).

3. ALL CAPACITANCE IS EXPRESSED IN MICROFARADS.

4. ALL INDUCTANCE IS EXPRESSED IN MICROHENRYS.

**NOTES:** (INVERTER SUPPLY PC BOARD)

- 1. NOT USED.
- 2. NOT USED.
- 3. L1 THRU L4 ARE 30 TURNS OF 18 GA WIRE.
- 4. SN1001 THRU SN1408, Q1506 NOT USED.
- 5. SN1001 THRU SN1408, CR1513 NOT USED, R20 IS 47K, 1/4 W, 5% TOLERANCE.
- 6. SN1001 THRU SN1377, JTB1501 NOT USED.
- 7. SN1001 THRU SN1746, CR1514 AND R1521 NOT USED, R11 IS 4.75 K, 1/4 W, 5% TOLERANCE.

**NOTES:** (BATTERY CHARGER PC BOARD)

- 1. NOT USED.
- 2. NOT USED.
- 3. SN1001 THRU SN1045, CR1605 AND CR1606 ARE 1N 4002 TYPE DIODES AND R1624 NOT USED.
- 4. SN1001 THRU SN1101, C1611 NOT USED.
- 5. DETAIL A EFFECTIVE WITH OVEN OSCILLATOR (.05 PPM) OPTION ONLY.

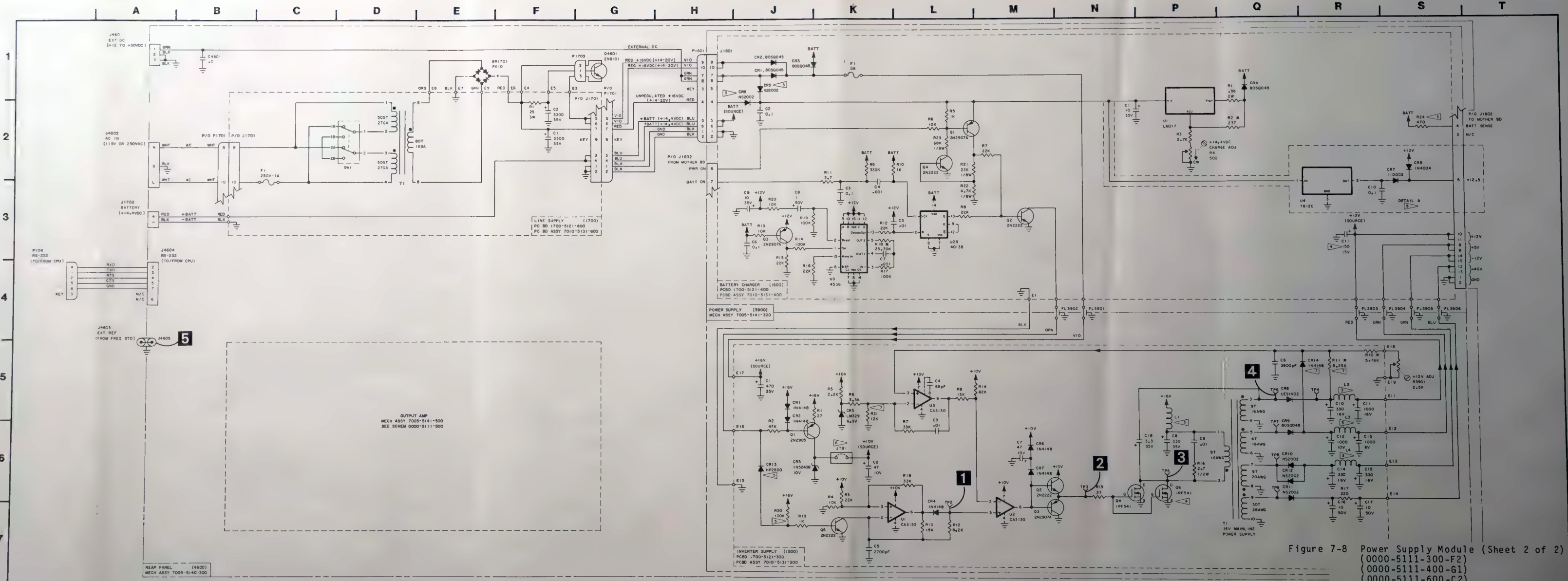
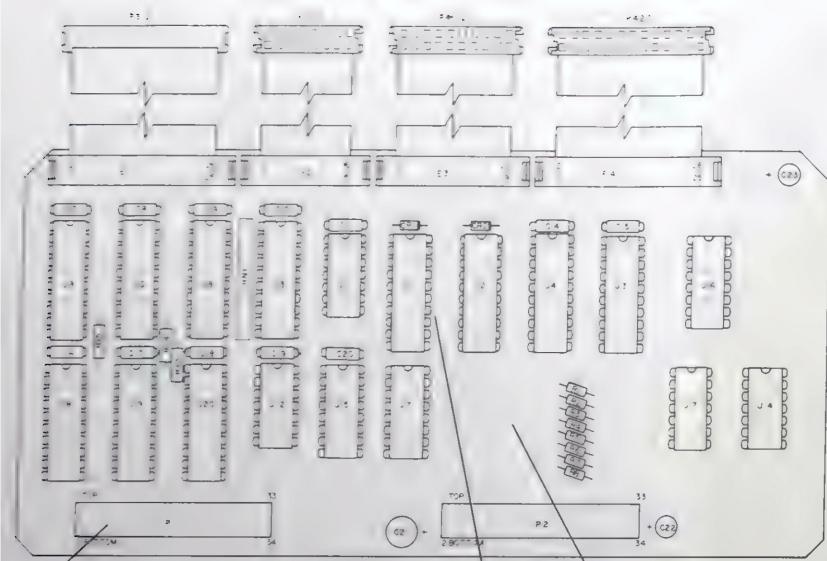
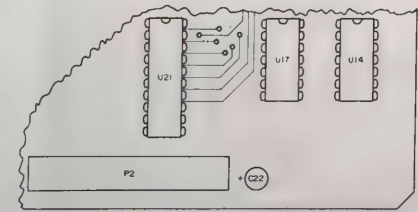
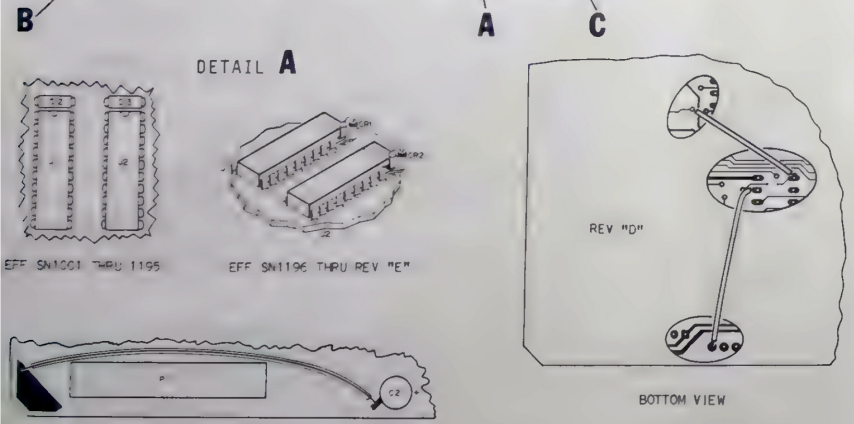

Figure 7-8 Power Supply Module (Sheet 2 of 2)  
(0000-5111-300-F2)  
(0000-5111-400-G1)  
(0000-5111-600-C2)



NOTES:

1. ALL REFERENCE NUMBERS CARRY ASSIGNED DESIGNATOR SERIES. THIS SCHEMATIC CARRIES SERIES 1000 (E.G., R1 IS R1001).
2. ALL RESISTORS ARE 1/4 W, 5% TOLERANCE UNLESS OTHERWISE NOTED.
3. ALL RESISTANCE IS EXPRESSED IN OHMS UNLESS OTHERWISE NOTED.
4. RESISTORS R1 THRU R8 ARE 100Ω, 1/8 W, 5% TOLERANCE.
5. ALL CAPACITANCE IS EXPRESSED IN MICROFARADS UNLESS OTHERWISE NOTED.
6. ALL INDUCTANCE IS EXPRESSED IN MICROHENRYS UNLESS OTHERWISE NOTED.



Interface PC Board (Rev J-1)

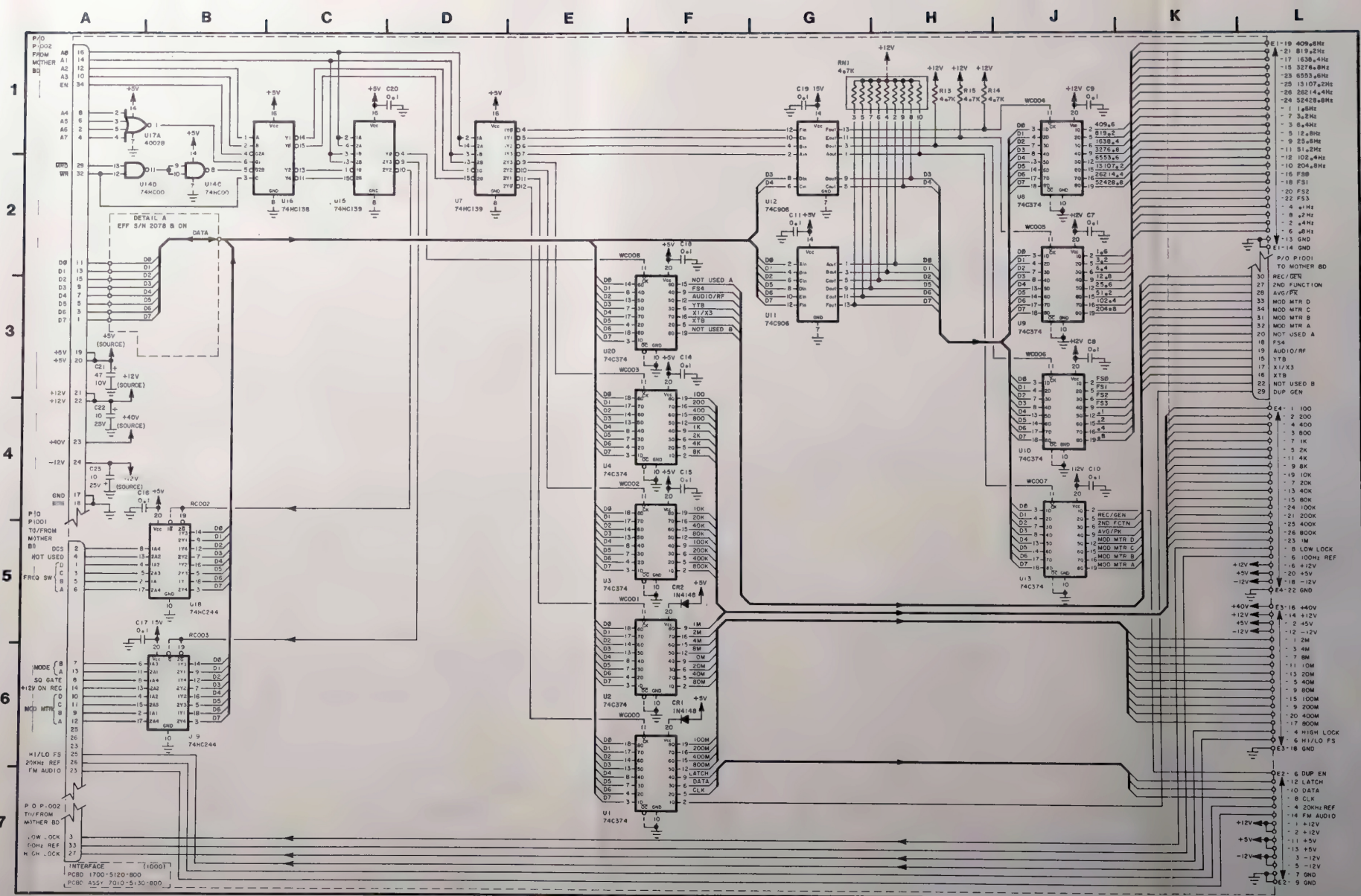

MODULATION METER CONTROL (P1001)										
MOD MTR CONTROL POSITION	INPUT					OUTPUT				
	MOD MTR A PIN 12	MOD MTR B PIN 9	MOD MTR C PIN 11	MOD MTR D PIN 10	MOD MTR E PIN 32	MOD MTR F PIN 31	MOD MTR G PIN 34	MOD MTR H PIN 33	MOD MTR I PIN 35	2ND FUNC PIN 27
MP	150	0	0	0	0	0	1	0	0	0
WR	150	0	1	0	0	0	0	1	0	0
kHz/SX10	15	1	1	0	0	1	0	1	0	0
	2	0	0	1	0	0	0	1	0	0
	6	1	0	1	0	1	1	0	0	0
	20	0	1	1	0	0	0	1	0	0
BATT	0	0	0	0	1	0	0	0	0	0
SIG	1	0	0	1	1	0	0	0	0	0
DIST	0	1	0	1	1	1	1	1	1	1
SINAD	1	1	0	1	1	1	1	1	1	1
1 = +5 VDC      0 = 0 VDC      1 = +12 VDC      0 = 0 VDC										

FREQ ERROR METER CONTROL (P1001)										
FREQ ERROR METER POSITION	INPUT					OUTPUT				
	FREQ SW A PIN 6	FREQ SW B PIN 5	FREQ SW C PIN 3	FREQ SW D PIN 1	XTB PIN 16	YTB PIN 15	X1/X3 PIN 17	AUDIO/RF PIN 19		
10	0	0	0	0	0	0	0	0	0	0
100	1	0	0	0	0	0	0	0	0	0
300	0	1	0	0	0	1	0	0	0	0
1K	1	1	0	0	0	1	0	1	0	0
3K	0	0	1	0	0	0	1	0	0	0
10K	1	0	0	0	0	0	1	1	0	0
AUDIO	3	0	1	1	0	1	0	0	0	1
	30	1	1	1	0	0	1	0	1	0
	300	0	0	0	1	1	1	1	0	1
	1 = +5 VDC      0 = 0 VDC      1 = +5 VDC      0 = 0 VDC									

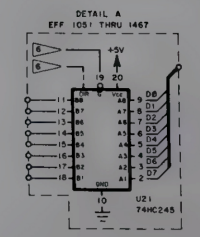

MODE CONTROL SWITCH				
MODE CONTROL POSITION	P1001 INPUT	P1001 OUTPUT	E1002-6 OUTPUT	
	MODE A PIN 13	MODE B PIN 30	REC/GEN PIN 30	DUP GEN PIN 29
GEN	0	0	0	0
REC	1	0	1	0
DUP	0	1	1	0
DUP/GEN	1	0	0	1
1 = +5VDC      0 = 0VDC      1 = 12VDC      * = +5VDC				

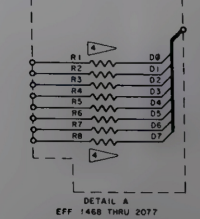
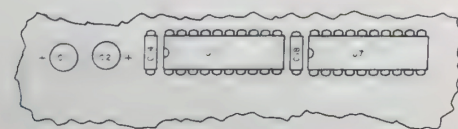
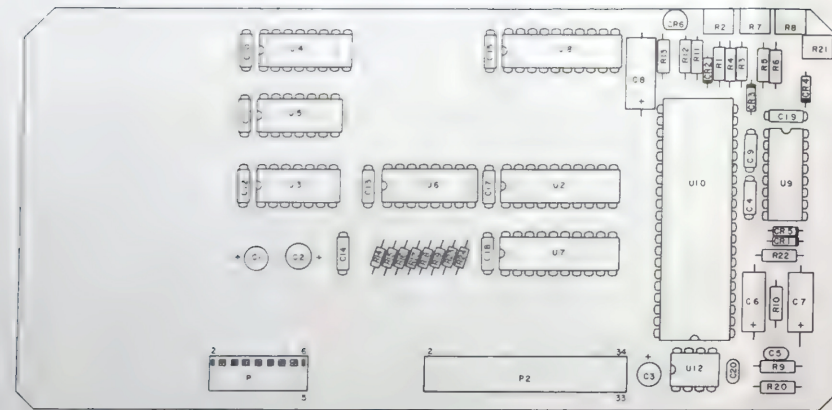

Figure 7-9 Interface PC Board Assembly (0000-5110-800-J)



EFF SN1001 THRU 1377



EFF SN1378 AND ON

DVM I/O PC Board (Rev B-5)

NOTES:

1. ALL REFERENCE NUMBERS CARRY ASSIGNED DESIGNATOR SERIES. THIS SCHEMATIC CARRIES SERIES 3000 (E.G., R1 IS R3001).
2. ALL RESISTORS ARE 1/4 W, 5% TOLERANCE UNLESS OTHERWISE NOTED.
3. ALL RESISTANCE IS EXPRESSED IN OHMS UNLESS OTHERWISE NOTED.
4. ALL CAPACITANCE IS EXPRESSED IN MICROFARADS UNLESS OTHERWISE NOTED.
5. ALL INDUCTANCE IS EXPRESSED IN MICROHENRYS UNLESS OTHERWISE NOTED.

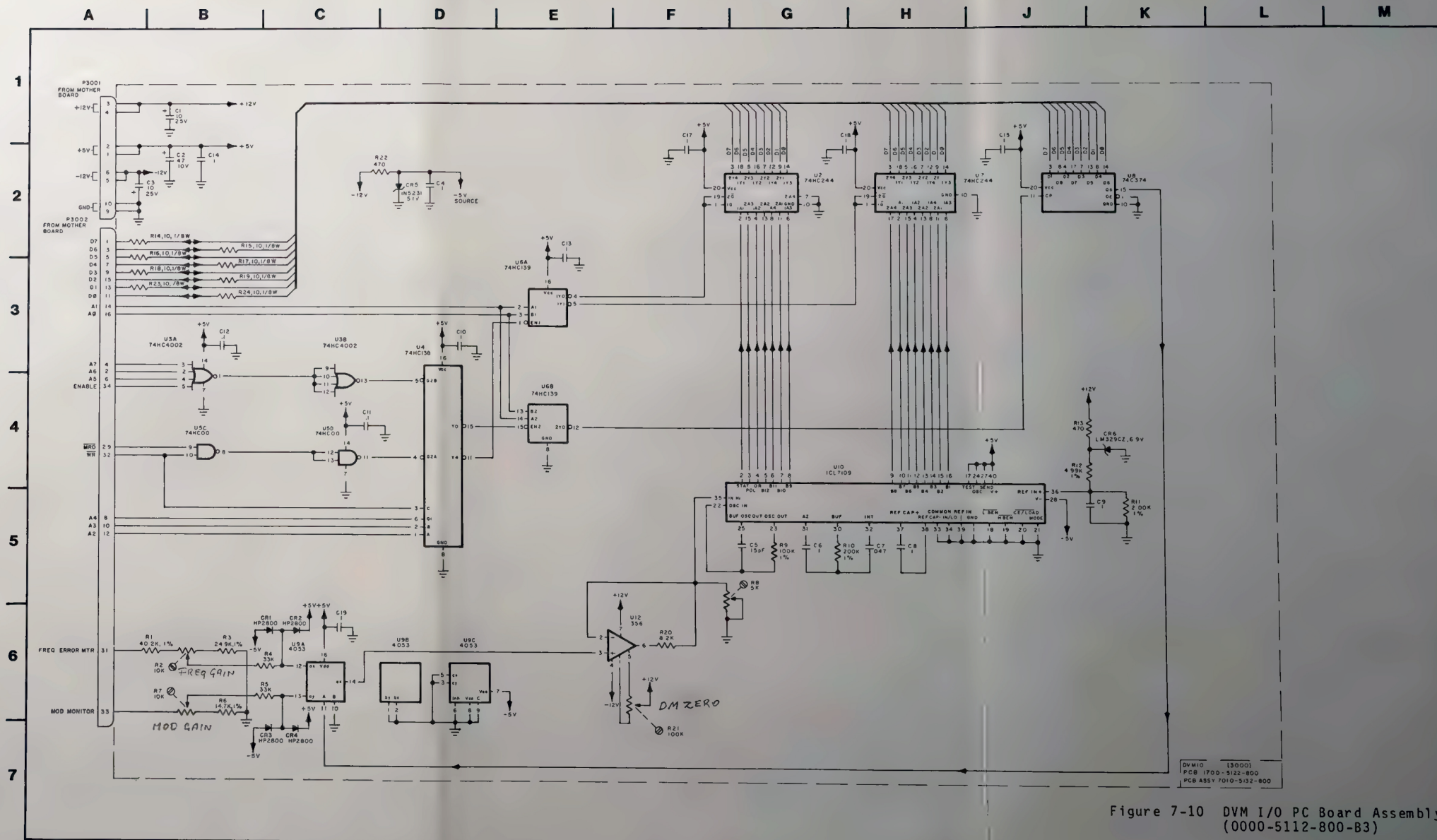
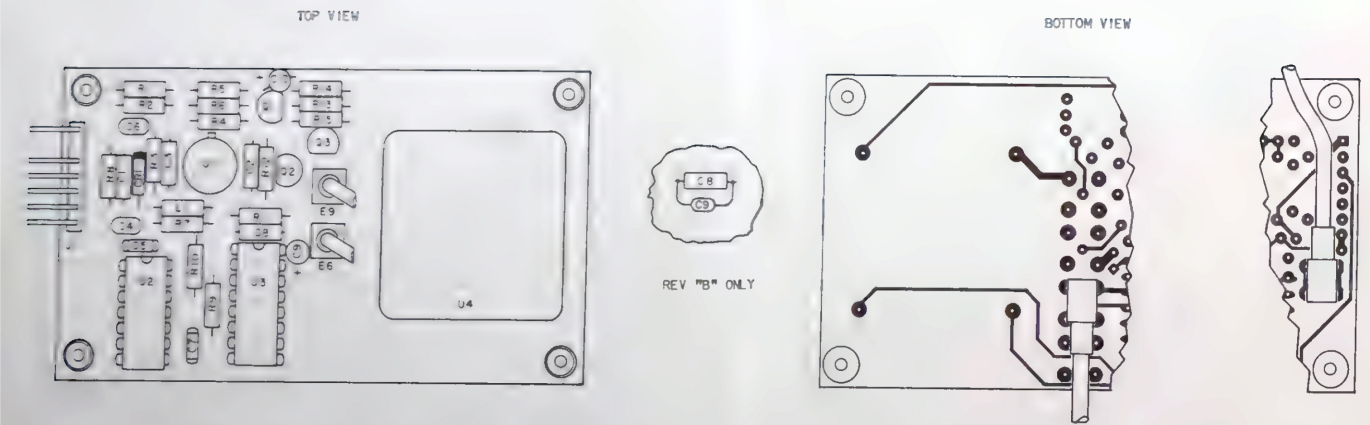
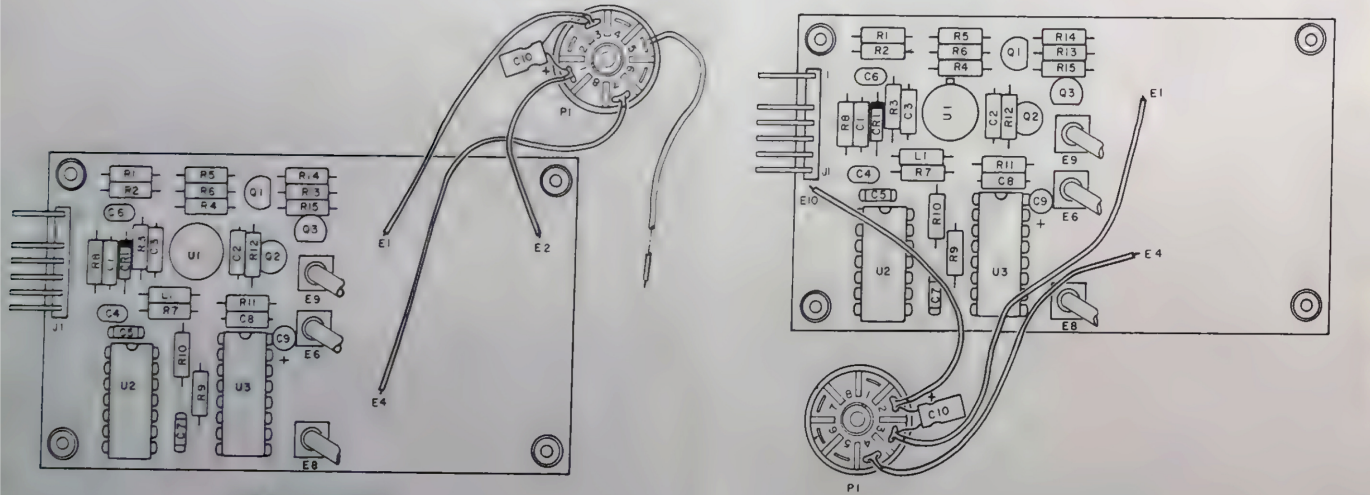

Figure 7-10 DVM I/O PC Board Assembly (0000-5112-800-B3)



STANDARD OPTION (.5 PPM TCXO)



OPTION 01 (.2 PPM TCXO)

OPTION 02 (.05 PPM TCXO)

Frequency Standard PC Board (Rev D-1)

- NOTES:
- ALL REFERENCE NUMBERS CARRY ASSIGNED DESIGNATOR SERIES. THIS SCHEMATIC CARRIES SERIES 2800 AND 3600 (E.G., R1 IS R2801, ETC.).
  - ONLY ONE (1) OSCILLATOR IS INSTALLED PER ASSY.
    - A. INSTALLED W/.05 PPM OSC ONLY.
    - B. INSTALLED W/.2 PPM OSC ONLY.
    - C. INSTALLED W/.5 PPM OSC ONLY.
  - ALL RESISTORS ARE 1/4 W, 5% TOLERANCE UNLESS OTHERWISE NOTED.
  - ALL RESISTANCE IS EXPRESSED IN OHMS UNLESS OTHERWISE NOTED.
  - ALL CAPACITANCE IS EXPRESSED IN MICROFARADS UNLESS OTHERWISE NOTED.
  - ALL INDUCTANCE IS EXPRESSED IN MICROHENRYS UNLESS OTHERWISE NOTED.

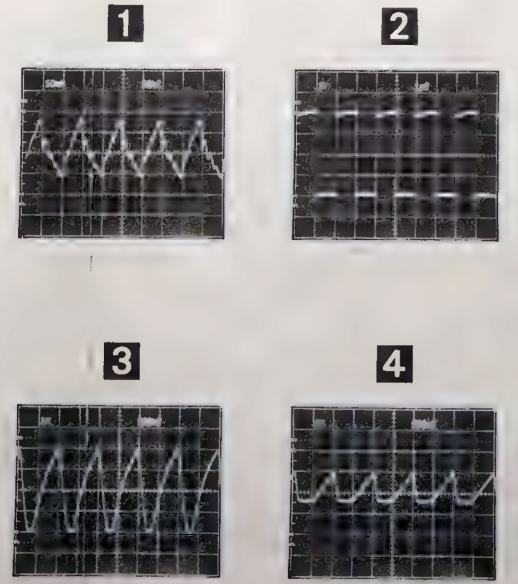

NOTE: ALL MEASUREMENTS WERE TAKEN USING A BNC TEE CONNECTOR WITH AN X1 PROBE.

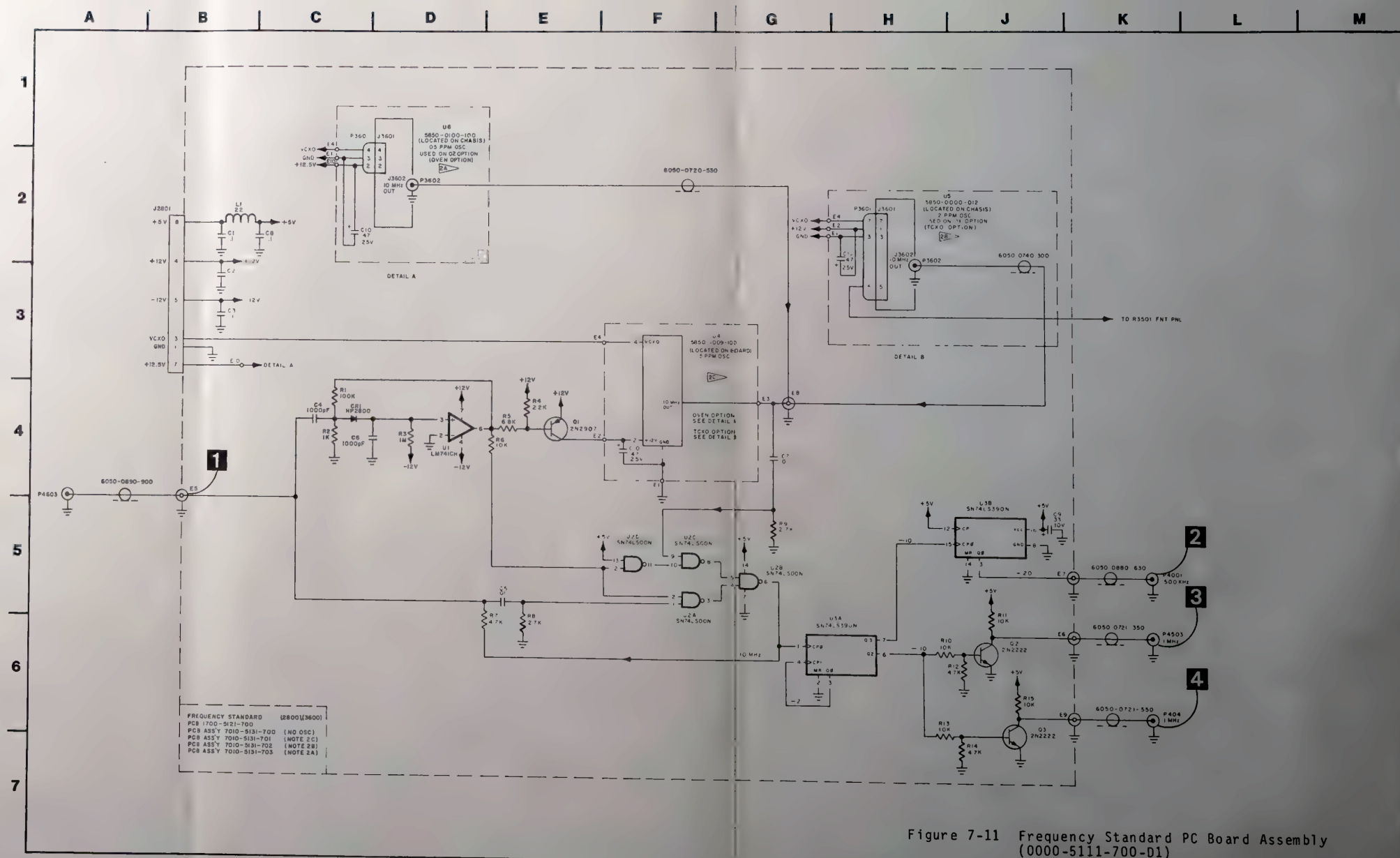
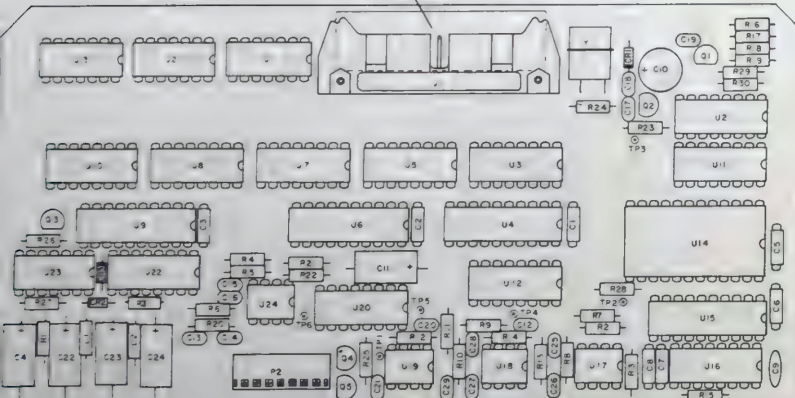

Figure 7-11 Frequency Standard PC Board Assembly (0000-5111-700-D1)



Function Generator PC Board (Rev B-7)

P3102 P.N.#	IDENTIFIER	REMARKS
4	<100 Hz	HIGH (+12 VDC) WHEN SELECTED TONE IS LESS THAN 102.4 Hz
6	<400 Hz	HIGH (+12 VDC) WHEN SELECTED TONE IS LESS THAN 409.6 Hz
5	< 1 kHz	HIGH (+12 VDC) WHEN SELECTED TONE IS LESS THAN 819.2 Hz

FUNCTION	A	B	C	D	E
SINE	0	0	0	0	0
SQUARE	1	0	0	0	0
RAMP	0	1	0	0	0
TRIANGLE	1	1	0	0	0
DTMF	X	X	1	0	1
PULSE	0	0	0	0	0
DCS	0	0	0	1	1

X - SELECT LINES A & B ARE HI IN DTMF WHEN NO TONE IS GENERATED. BOTH GO LOW WHEN GENERATING A TONE.

FUNCTION SELECTED	FILTER USED
SINEWAVE AND DCS	
<819.2 Hz	1 kHz
819.2 THRU 13106.2 Hz	10 kHz
13106.2 Hz	60 kHz
SQUARE, RAMP, AND TRIANGLE	
<819.2 Hz	10 kHz
819.2 Hz	60 kHz
DTMF	1 kHz

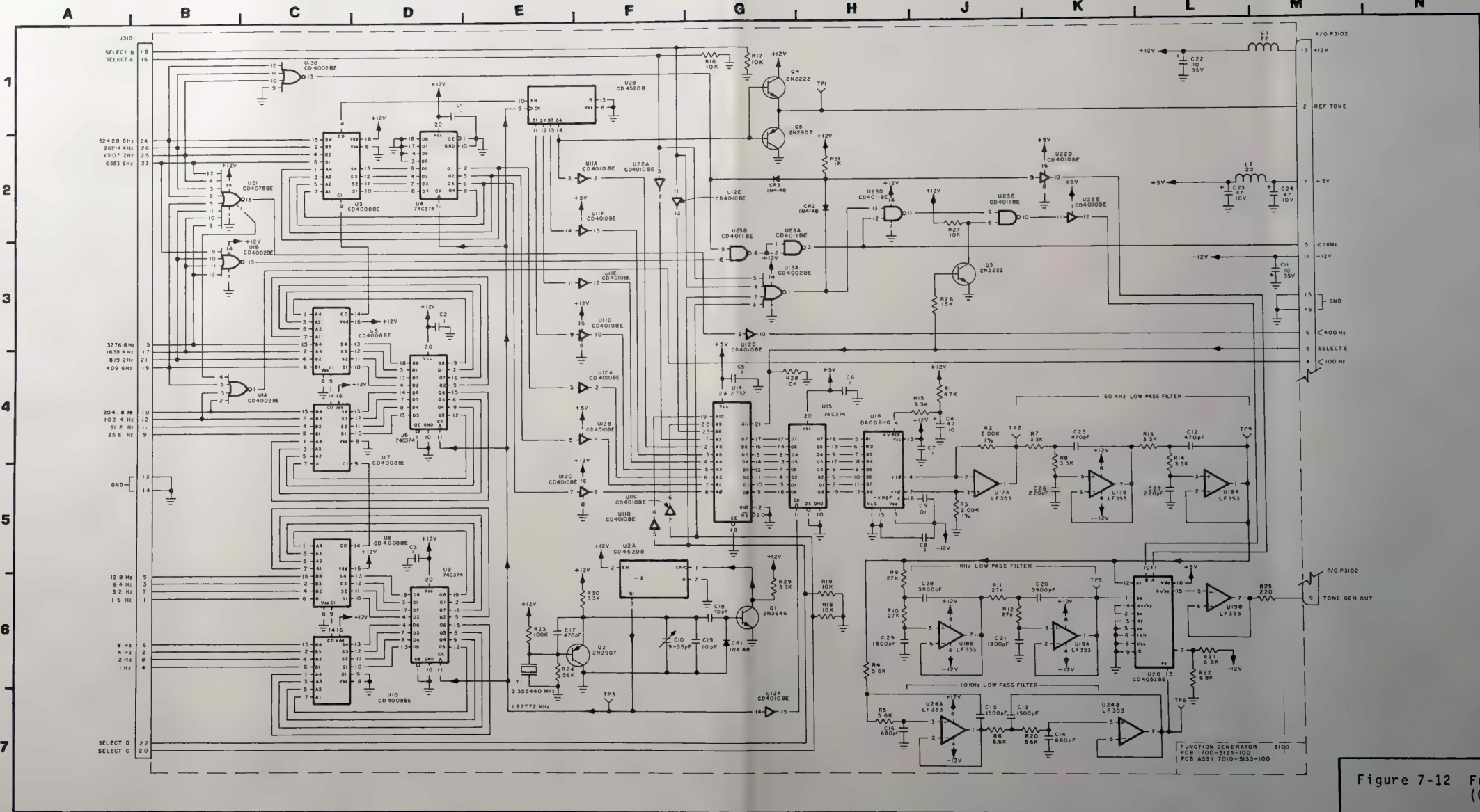

- NOTES:
- ALL REFERENCE NUMBERS CARRY AN ASSIGNED DESIGNATOR SERIES. THIS SCHEMATIC CARRIES SERIES 3100. (E.G., R1 IS R3101).
  - ALL RESISTORS ARE 1/4 W, 5% TOLERANCE UNLESS OTHERWISE NOTED.
  - ALL RESISTANCE IS EXPRESSED IN OHMS UNLESS OTHERWISE NOTED.
  - ALL CAPACITANCE IS EXPRESSED IN MICROFARADS UNLESS OTHERWISE NOTED.
  - ALL INDUCTANCE IS EXPRESSED IN MICROHENRYS UNLESS OTHERWISE NOTED.
  - APPLY TWO STRIPS OF MYLAR TAPE (1/4" WIDE X 1 3/4" LONG).

Figure 7-12 Function Generator PC Board Assembly (0000-5113-100-85)

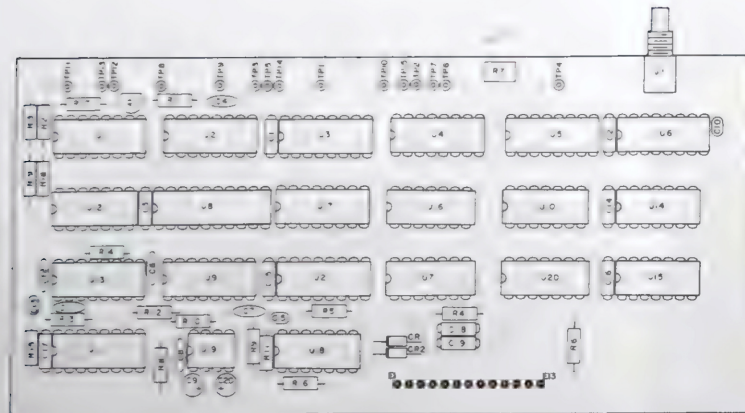

Digital Counter PC Board (Rev B)

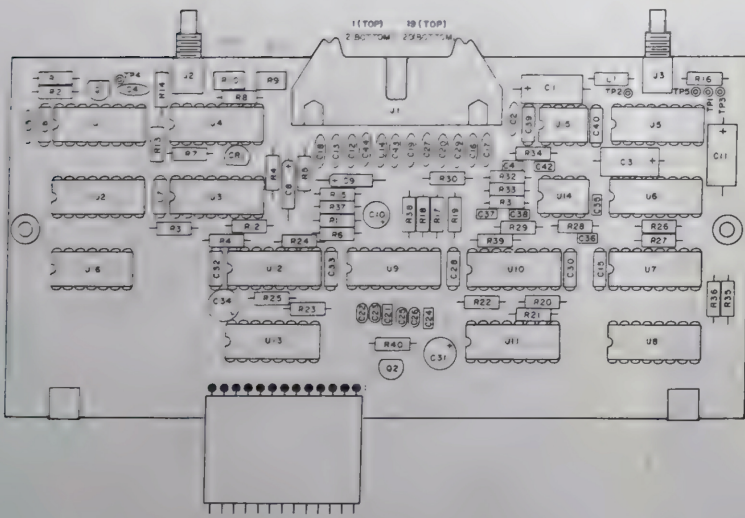

Digital Reference PC Board (Rev F-2)

J4501		FREQ ERROR SELECT CODING								
		S3702 FREQ ERROR METER RANGE POSITION								
		RF					AUDIO			
PIN #	IDENTIFIER	30	100	300	1K	3K	10K	3	50	300
1	X3/X10	0	1	0	1	0	1	0	0	0
11	AUDIO/RF	0	0	0	0	0	0	1	1	1
19	XTB	0	0	1	1	0	0	1	0	1
20	YTB	0	0	0	0	1	1	0	1	1
TIME BASE		10 Hz	100 Hz	1 kHz	100 Hz	1 kHz	10 kHz			

J4501 PIN #2 (GEN TUNE) IS TYPICALLY +5.0 VDC

TEST POINTS	RF SETTINGS					
	30	100	300	1K	3K	10K
TP4401	0	0	1	1	0	0
TP4402	1	1	1	1	1	1
TP4403	0	0	0	0	1	1
TP4404	1	1	1	1	1	0
TP4405	1	1	0	0	0	0
TP4406	1	1	0	0	1	1
TP4407	0	0	1	1	1	1

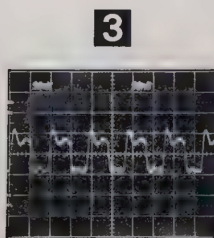
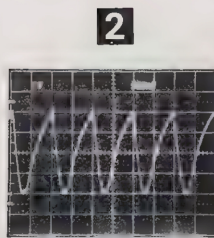
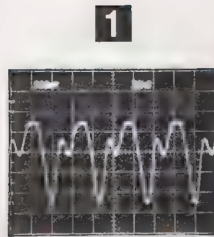

NOTE: ALL MEASUREMENTS WERE TAKEN USING A BNC TEE CONNECTOR WITH AN X1 PROBE.

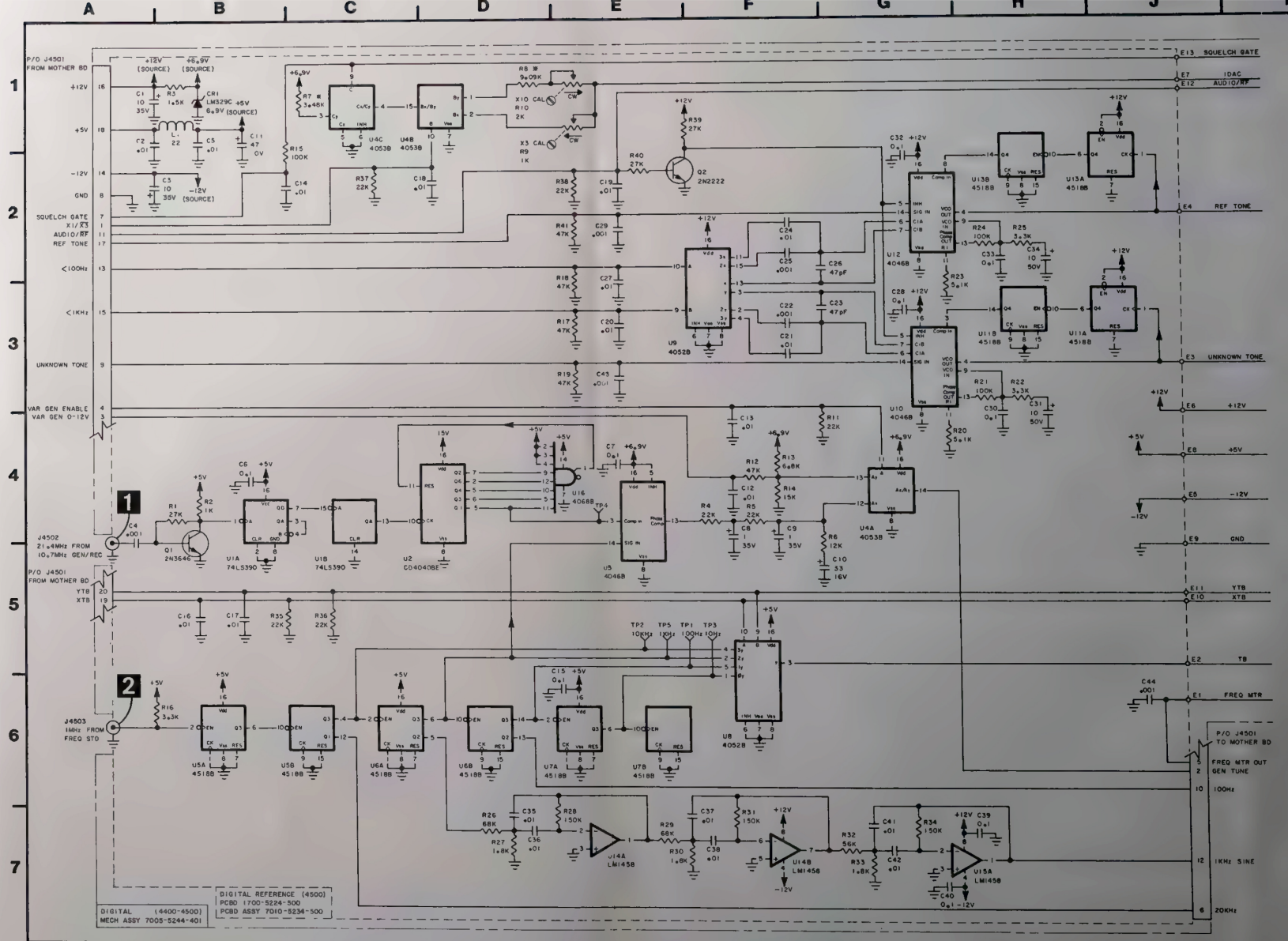
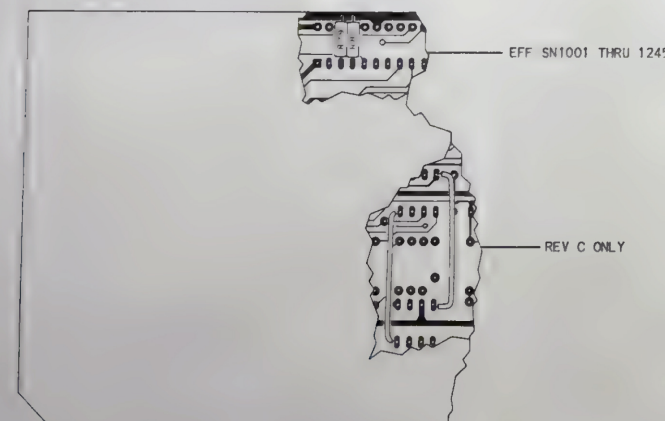
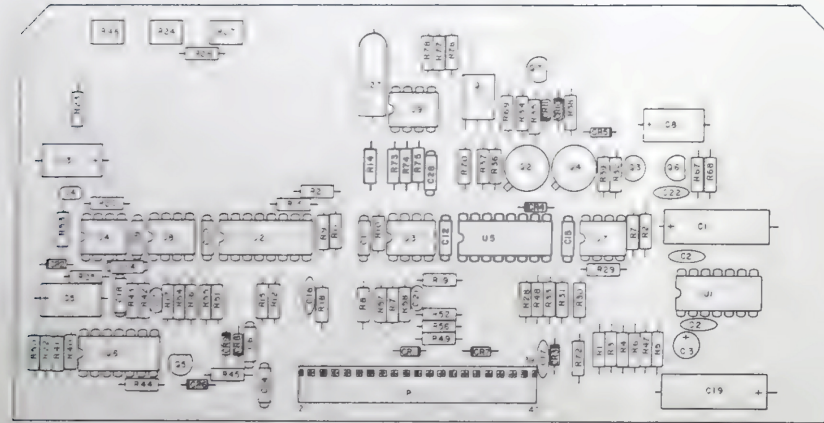

Figure 7-13 Digital Module (Sheet 1 of 2)  
(0000-5214-400-C1)  
(0000-5214-500-D)





Generate Audio PC Board (Rev P-1B)

P3201		REMARKS
PIN	IDENTIFIER	
4	GEN LVL DET	POSITIVE D.C. VOLTAGE PROPORTIONAL TO R.F. DETECTED IN THE OUTPUT AMP.
6	LOW LOCK	+5 VDC WHEN LOW LOOP IS PHASE LOCKED
8	HIGH LOCK	+5 VDC WHEN HIGH LOOP IS PHASE LOCKED
17	MOD MTR D	+12 VDC WHEN MODULATION METER CONTROL IS IN DIST OR SINAD
21	TO NE KEY	GROUND ON THIS LINE, WHEN IN GEN MODE, DISABLES FUNCTION GENERATOR OUTPUT
27	AM	+12 VDC WHEN MODULATION SELECT CONTROL IS IN AM NORM, AM VAR, AND SSB
31	MIKE KEY	GROUND WHEN MICROPHONE PTT SWITCH IS DEPRESSED
35	POWER SENSE	POSITIVE DC VOLTAGE PROPORTIONAL TO THE STRENGTH OF ANY RF RECEIVED AT THE T/R CONN

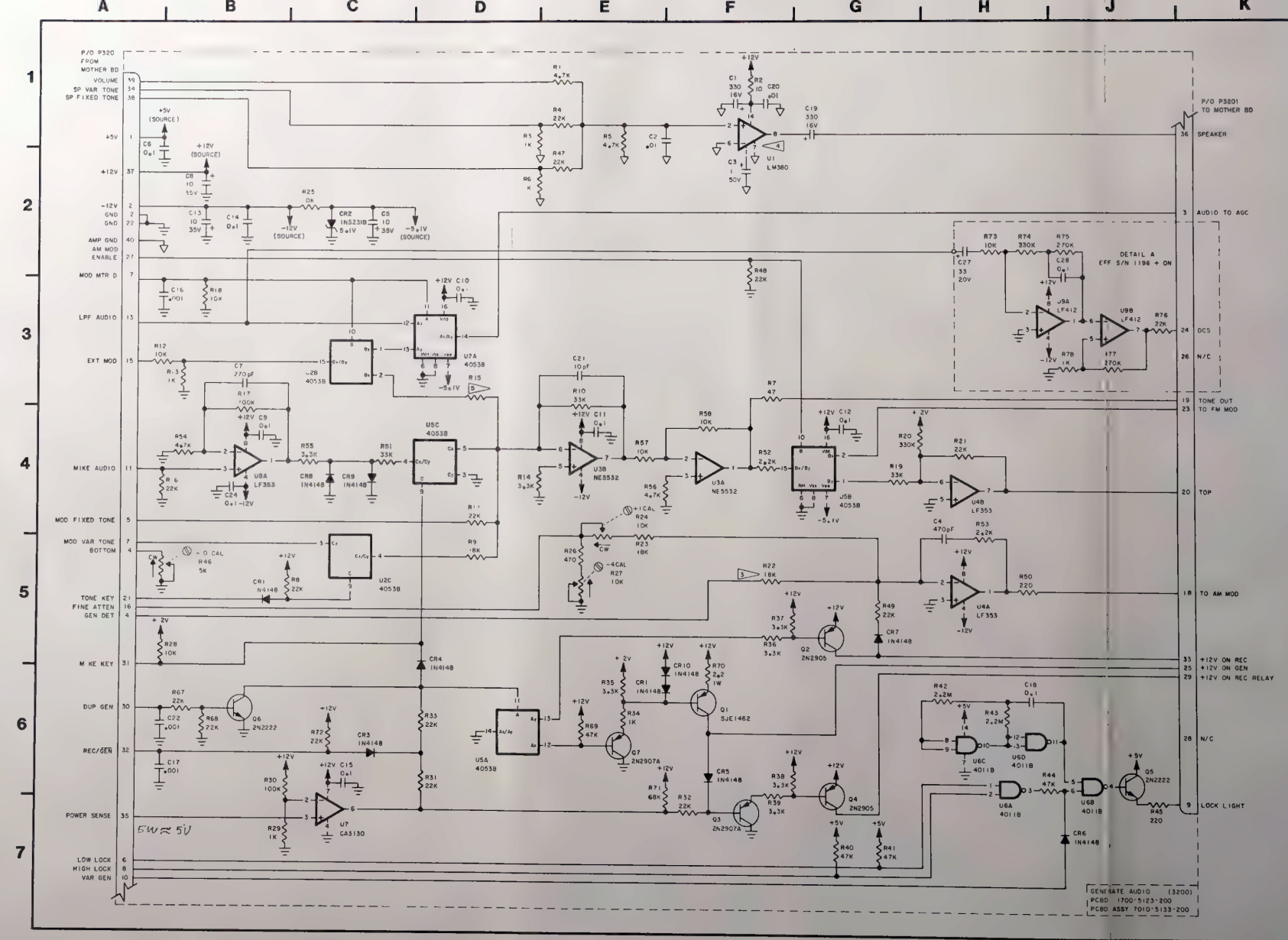

- NOTES:
- ALL REFERENCE DESIGNATORS CARRY ASSIGNED DESIGNATOR SERIES. THIS SCHEMATIC CARRIES SERIES 3200 (E.G., R1 IS R3201).
  - ALL CAPACITANCE IS EXPRESSED IN MICROFARADS UNLESS OTHERWISE NOTED.
  - SN1001 THRU SN1747, R22 IS A 15 K, 1/4 W, 5% TOLERANCE RESISTOR.
  - PINS 3, 4, 5, 10, 11 AND 12 ARE GROUNDED FOR HEAT DISSIPATION.
  - R15 IS SELECTED AT TEST (SAT). NOMINAL IS 5.6 K. RANGE IS 2.7 K TO 8.2 K.
  - ALL RESISTORS ARE 1/4 W, 5% TOLERANCE UNLESS OTHERWISE NOTED.
  - ALL RESISTANCE IS EXPRESSED IN OHMS UNLESS OTHERWISE NOTED.
  - ALL INDUCTANCE IS EXPRESSED IN MICROHENRYS UNLESS OTHERWISE NOTED.

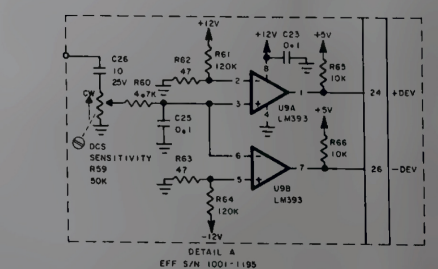
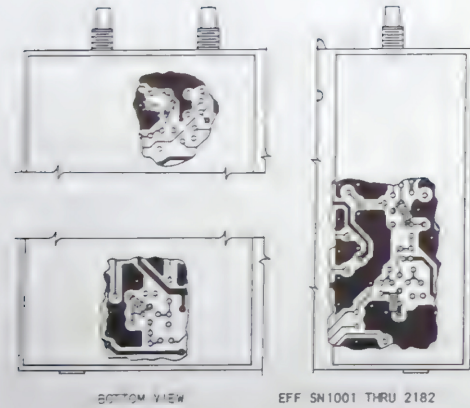

Figure 7-14 Generate Audio Module (0000-5113-200-D2)



BOTTOM VIEW EFF SN1001 THRU 2182



EFF SN1001 THRU 2182 DETAIL A

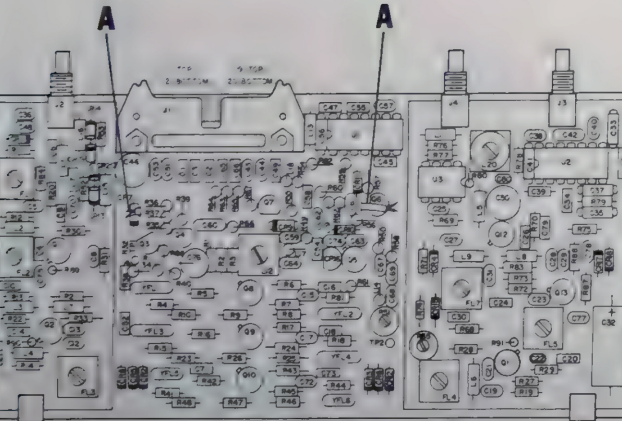

10.7 MHz Gen/Rec PC Board (Rev R)

NOTE: ALL MEASUREMENTS WERE TAKEN USING AN X10 PROBE.

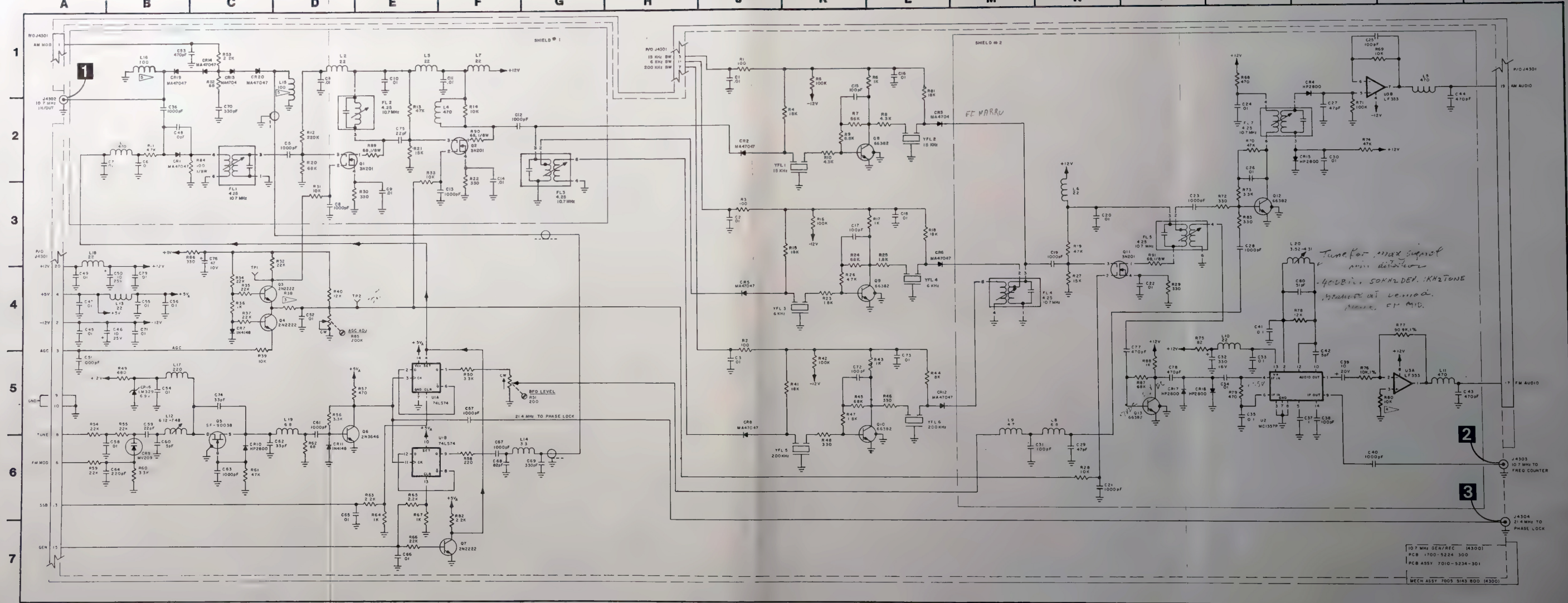
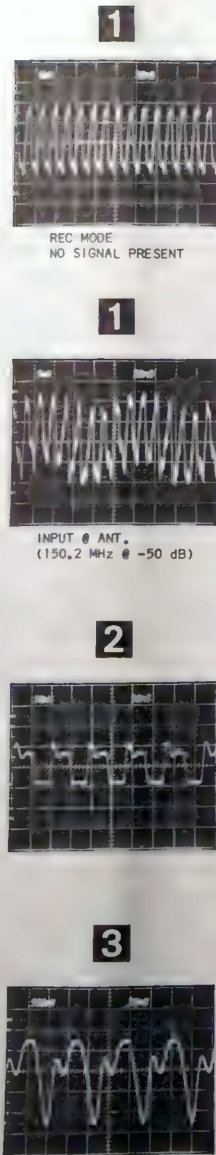

NOTES:

- ALL REFERENCE NUMBERS CARRY ASSIGNED DESIGNATOR SERIES. THIS SCHEMATIC CARRIES SERIES 4300 (E.G., R1 IS R4301).
- ALL CAPACITANCE IS EXPRESSED IN MICROFARADS UNLESS OTHERWISE NOTED.
- R38 IS SELECTED AT TEST (SAT). NOMINAL IS 6.8 K. RANGE IS 4.7 K TO 15 K.
- SN1001 THRU SN1055, R80 IS 150 K.
- CR19 AND CR20 NOT USED IN SN1001 THRU SN2182.

- ALL RESISTORS ARE 1/4 W, 5% TOLERANCE UNLESS OTHERWISE NOTED.
- ALL RESISTANCE IS EXPRESSED IN OHMS UNLESS OTHERWISE NOTED.
- ALL INDUCTANCE IS EXPRESSED IN MICROHENRYS UNLESS OTHERWISE NOTED.

Figure 7-15 10.7 MHz Gen/Rec Module (0000-5113-800-J)

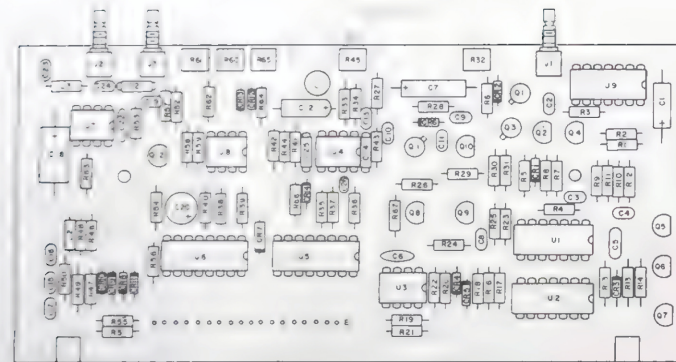

EFF SN2077 AND ON



EFF SN1001 THRU 2076

High Loop Analog PC Board (Rev C-1)

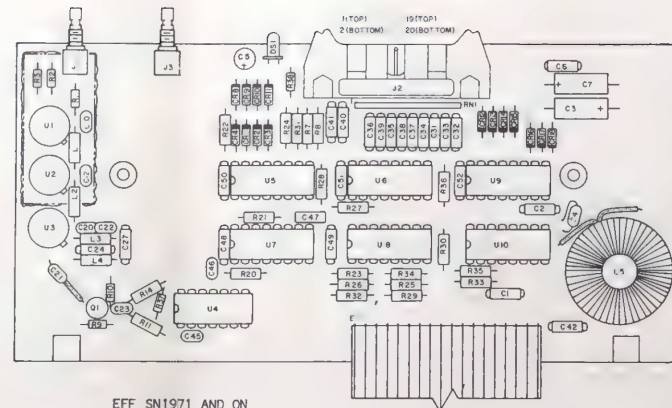

EFF SN1971 AND ON

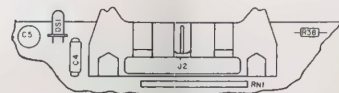

EFF SN1001 THRU 1970



BOTTOM VIEW

High Loop Divider PC Board (Rev E-2)

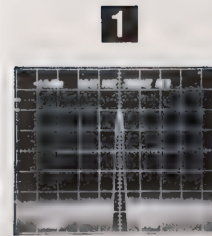

1

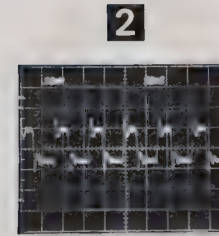

2



3



4



5

X1 PROBE



6

TOP TRACE Q11, PIN S  
BOTTOM TRACE Q11, PIN G

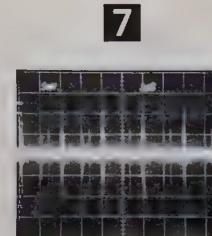

7

NOTE: ALL MEASUREMENTS WERE TAKEN WITH FM/AM-1200 FREQUENCY SET ON 150.2 MHz USING AN X10 PROBE.

NOTES:

1. ALL REFERENCE NUMBERS CARRY ASSIGNED DESIGNATOR SERIES. THIS SCHEMATIC CARRIES SERIES:
  - A. 4000 (HIGH LOOP ANALOG PC BOARD).
  - B. 4100 (HIGH LOOP DIVIDER PC BOARD).
  - C. (E.G., R1 IS R4001, ETC.).
2. ALL CAPACITANCE IS EXPRESSED IN MICROFARADS UNLESS OTHERWISE NOTED.
3. R4137 IS SELECTED AT TEST (SAT). NOMINAL IS 33 OHMS. RANGE IS 22 OHMS TO 56 OHMS.
4. ALL RESISTORS ARE 1/4 W, 5% TOLERANCE UNLESS OTHERWISE NOTED.
5. ALL RESISTANCE IS EXPRESSED IN OHMS UNLESS OTHERWISE NOTED.
6. ALL INDUCTANCE IS EXPRESSED IN MICROHENRYS UNLESS OTHERWISE NOTED.

Figure 7-16 High Loop Module (Sheet 1 of 2)  
(0000-5114-100-C)



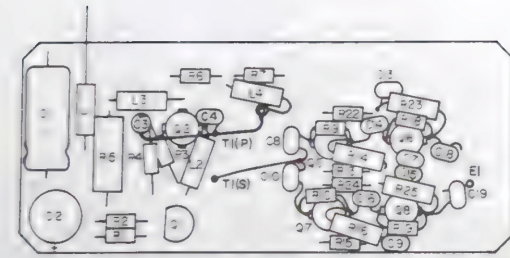

1210 MHz VCO PC Board (Rev H)

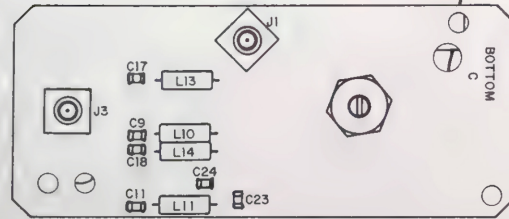
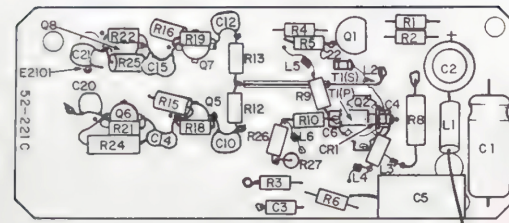

1300-2300 MHz VCO PC Board (Rev R)



VCO Mixer Assembly (Rev C)

NOTES:

1. ALL REFERENCE NUMBERS CARRY ASSIGNED DESIGNATOR SERIES. THIS SCHEMATIC CARRIES SERIES:
  - A. 1900 (VCO MIXER PC BOARD).
  - B. 2000 (1210 MHz VCO PC BOARD).
  - C. 2100 (1300-2298 MHz VCO PC BOARD).
  - D. (E.G., R1 IS R1901, ETC.).
2. ALL RESISTORS ARE 1/8 W, 5% TOLERANCE UNLESS OTHERWISE NOTED.
3. PRIMARY (T2001) IS FORMED BY LEAD OF C2004 PLACED 0.38 INCHES FROM SECONDARY. SECONDARY T2001 IS FORMED BY 22 GA WIRE 0.8 IN. LONG.
4. 10 TURNS, 38 GA WIRE 0.014 IN. DIA.
5. PRIMARY T2101 IS FORMED BY LEAD OF C2106 SOLDERED TO CR2101, LENGTH SELECTED AT TEST (SAT). SECONDARY T2101 IS 22 GA WIRE BENT TO WITHIN 0.4 IN. OF BOARD SURFACE THEN BACK TO WITHIN 0.2 IN. OF PRIMARY.
6. R2108 IS SELECTED AT TEST (SAT). NOMINAL IS 18Ω. RANGE IS 4Ω TO 22Ω.
7. TORR10D 18 GA, 30 TURNS.
8. SN1001 THRU SN1651, C6 IS 1200 pF.
9. SN1001 THRU SN1045, C25 NOT USED.
10. SN1001 THRU SN2077, R6 IS 56Ω.
11. ALL RESISTANCE IS EXPRESSED IN OHMS UNLESS OTHERWISE NOTED.
12. ALL CAPACITANCE IS EXPRESSED IN MICROFARADS UNLESS OTHERWISE NOTED.
13. ALL INDUCTANCE IS EXPRESSED IN MICROHENRYS UNLESS OTHERWISE NOTED.

1

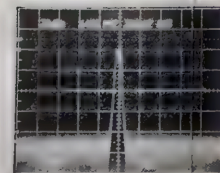

2

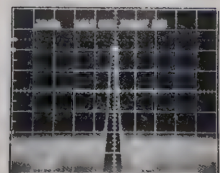

3

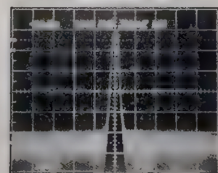

NOTE: ALL MEASUREMENTS WERE TAKEN WITH FM/AM-1200 FREQUENCY SET ON 150.2 MHz.

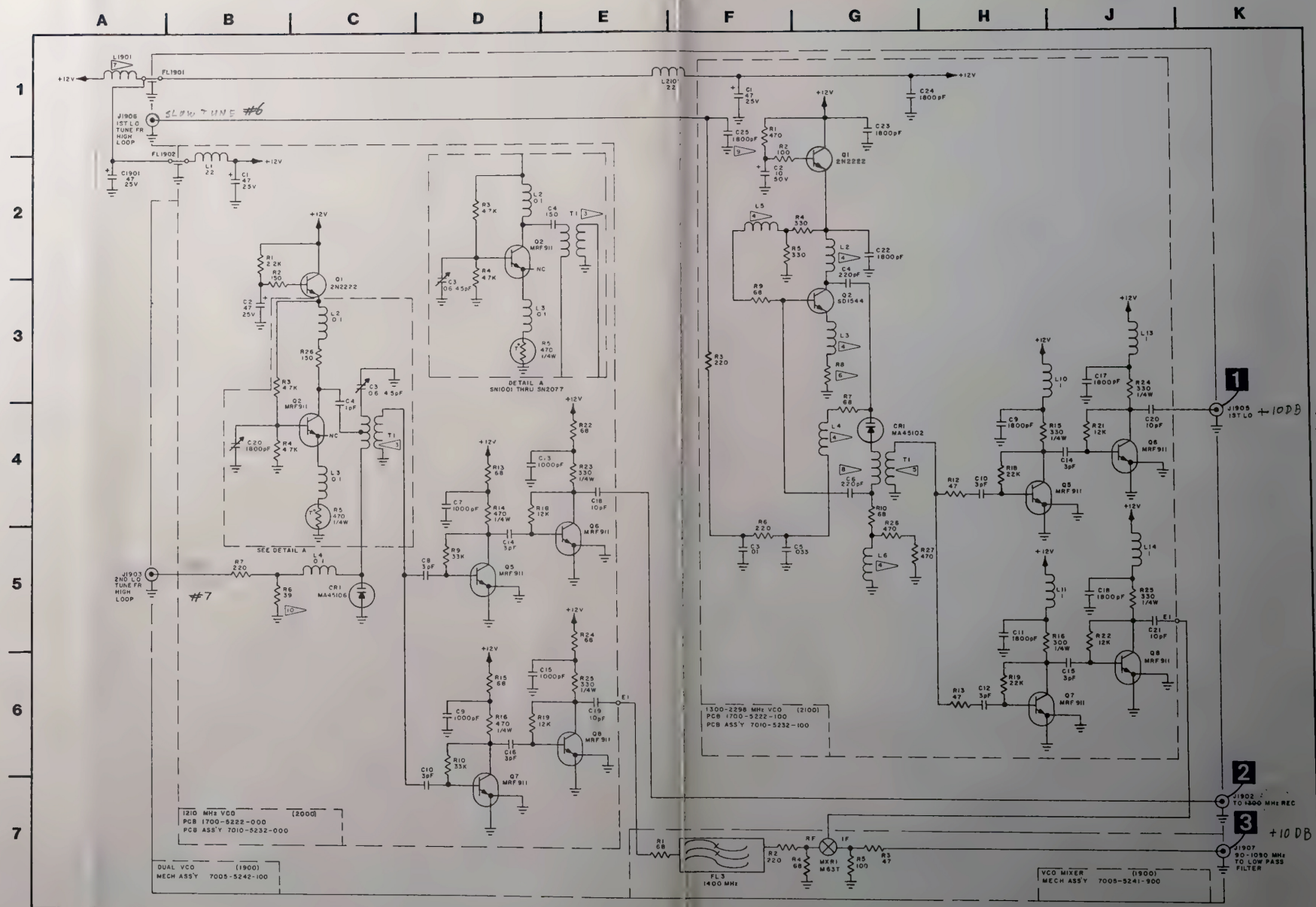

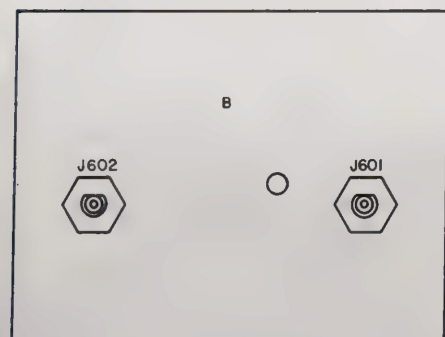
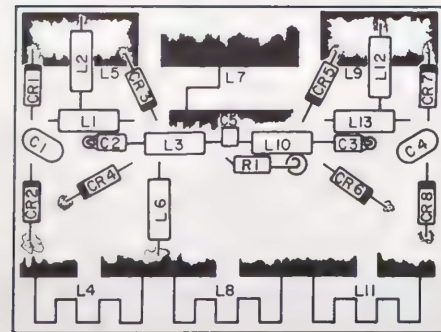

High/Low Pass Filter PC Board (Rev B-3)

NOTES:

1. ALL REFERENCE NUMBERS CARRY ASSIGNED DESIGNATOR SERIES. THIS SCHEMATIC CARRIES SERIES 600 AND 700 (E.G., C1 IS C701).
2. ALL RESISTORS ARE 1/8 W, 5% TOLERANCE UNLESS OTHERWISE NOTED.
3. ALL RESISTANCE IS EXPRESSED IN OHMS UNLESS OTHERWISE NOTED.
4. ALL CAPACITANCE IS EXPRESSED IN MICROFARADS UNLESS OTHERWISE NOTED.
5. ALL INDUCTANCE IS EXPRESSED IN MICROHENRYS UNLESS OTHERWISE NOTED.
6. ALL SHADED AREAS INDICATE MICRO-STRIPPING.
7. L4, L5, L7, L8, L9, AND L11 ARE PRINTED CIRCUIT COMPONENTS.

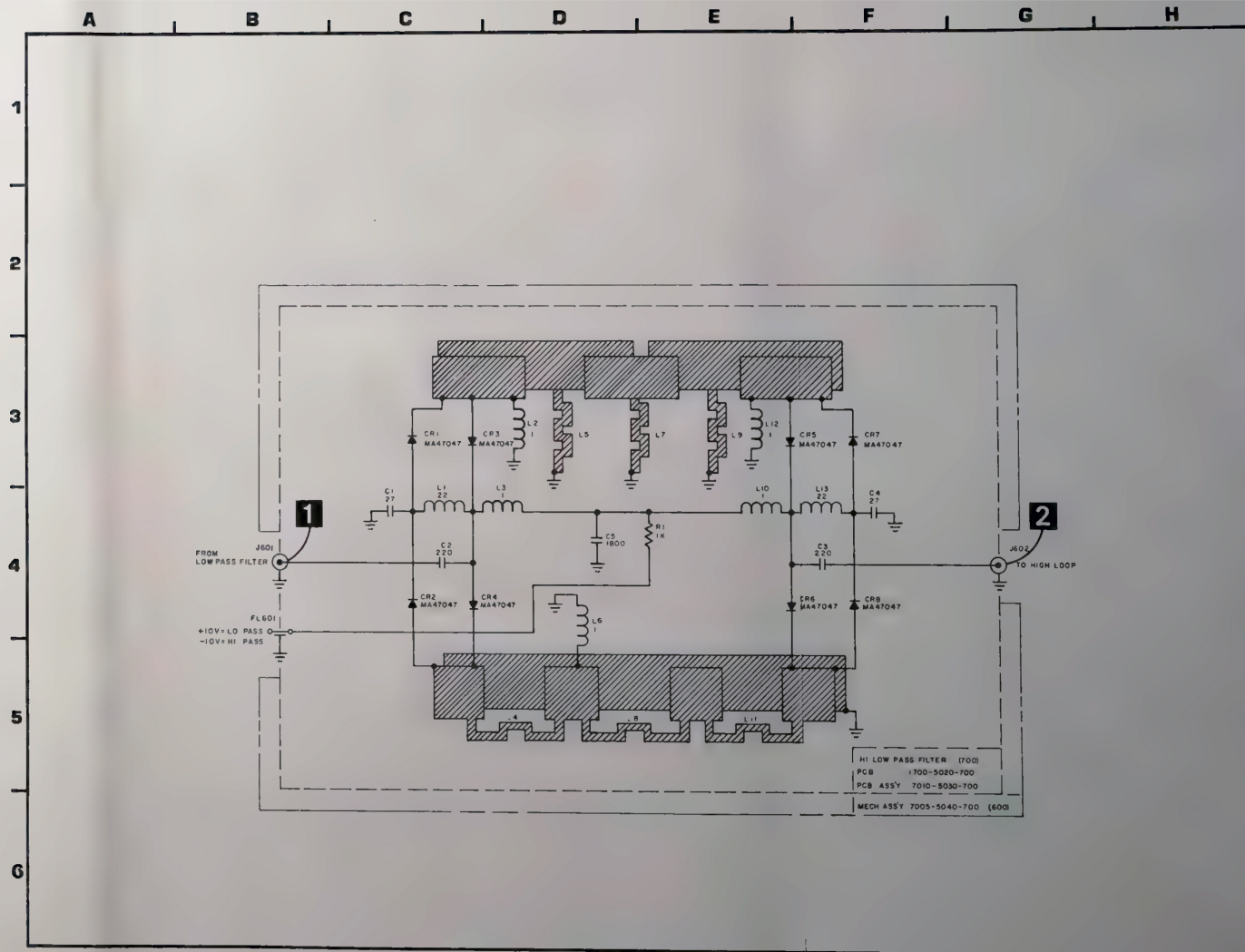
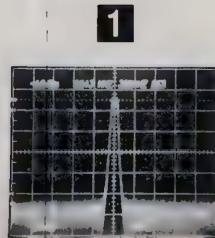
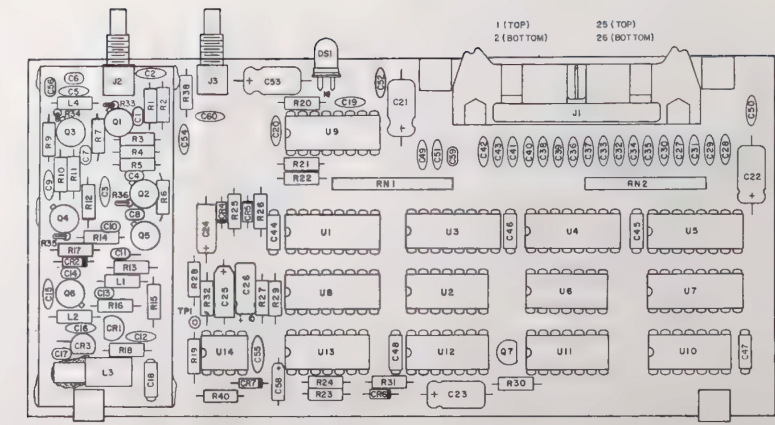
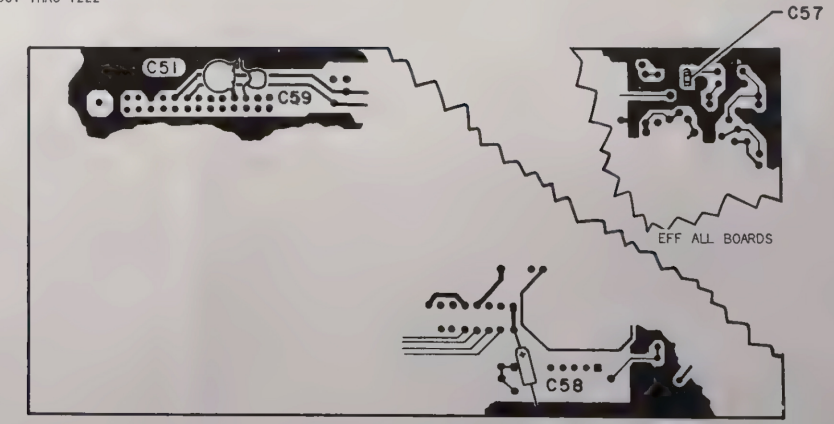
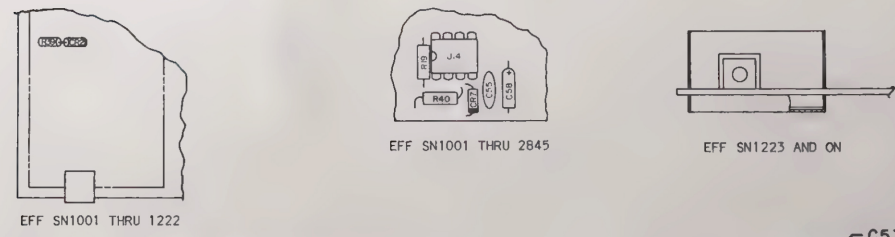

Figure 7-18 High/Low Pass Filter Assembly (0000-5010-700-B)



FM/AM 1200 FREQ. SETTING	LOW LOOP OUTPUT FREQ.	TUNE VOLTAGE TP 4201
0.0000	79.30000	6.00 VDC ± .5 V
1.0000	78.30000	4.50 VDC ± .5 V
1.9999	77.30010	3.00 VDC ± .5 V

- NOTES:
- ALL REFERENCE NUMBERS CARRY ASSIGNED DESIGNATOR SERIES. THIS SCHEMATIC CARRIES SERIES 4200 (E.G., R1 IS R4201).
  - ALL RESISTORS ARE 1/4 W, 5% TOLERANCE UNLESS OTHERWISE NOTED.
  - SN1001 THRU SN1222, R17 IS 100 K.
  - SN1001 THRU SN1287, R16 IS 470Ω.
  - SN1223 AND ON, R39 NOT USED.
  - SN1001 THRU SN1222, U14B, PIN 4 GOES DIRECTLY TO -12 V. R40 AND CR7 NOT USED.
  - ALL RESISTANCE IS EXPRESSED IN OHMS UNLESS OTHERWISE NOTED.
  - ALL CAPACITANCE IS EXPRESSED IN MICROFARADS UNLESS OTHERWISE NOTED.
  - ALL INDUCTANCE IS EXPRESSED IN MICROHENRYS UNLESS OTHERWISE NOTED.



Low Loop Synthesizer PC Board (Rev C)

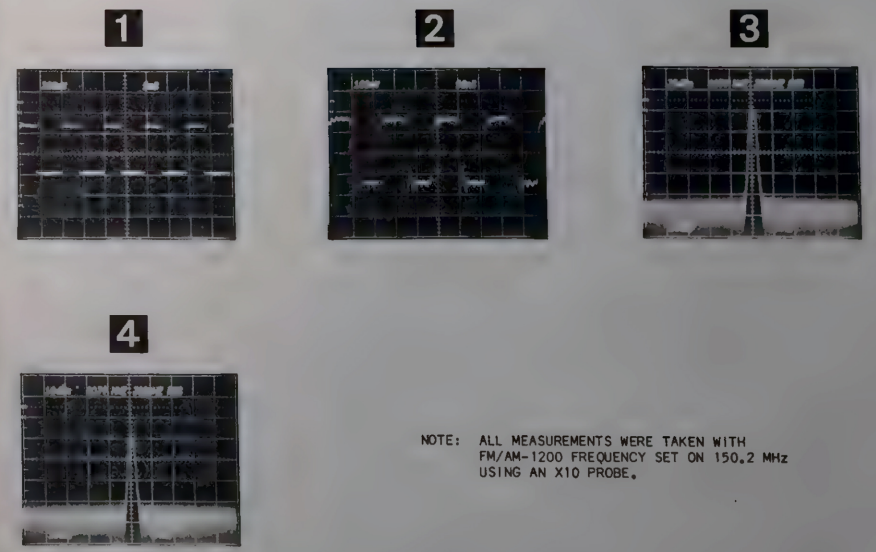

NOTE: ALL MEASUREMENTS WERE TAKEN WITH FM/AM-1200 FREQUENCY SET ON 150.2 MHz USING AN X10 PROBE.

Figure 7-19 Low Loop Module (Sheet 1 of 2) (0000-5214-200-H)

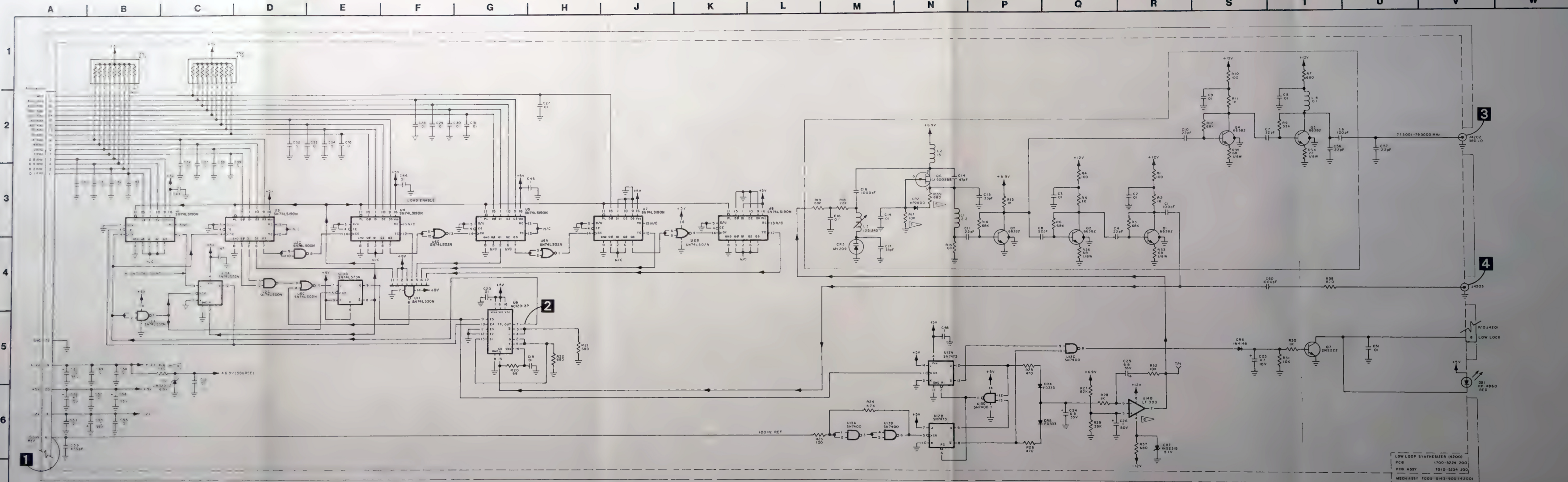
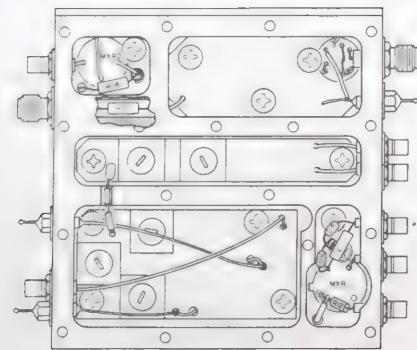
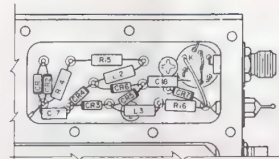

Figure 7-19 Low Loop Module  
 (Sheet 2 of 2)  
 (0000-5214-200-H)



IF Block Assembly (Rev J)



IF Amp PC Board (Rev C-2)

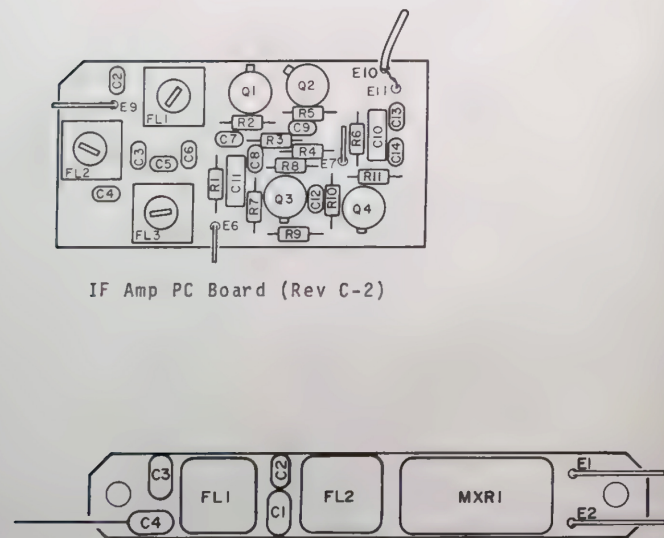

IF Mixer PC Board (Rev A)

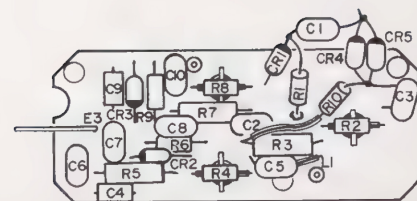

1300 MHz Amp PC Board (Rev B)

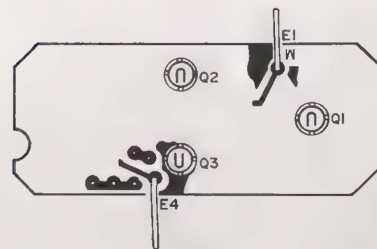

IF Voltage Protect PC Board (Rev B-1)

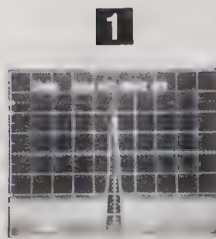
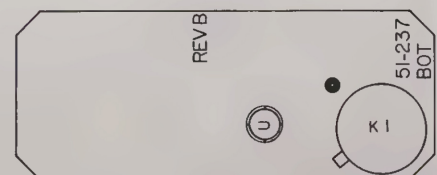
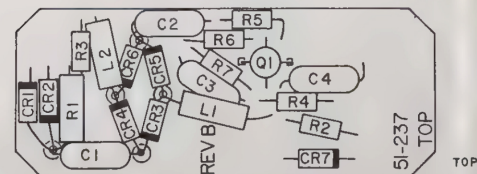

1

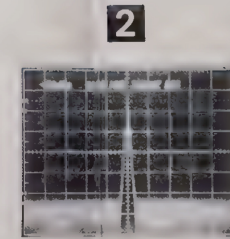

2

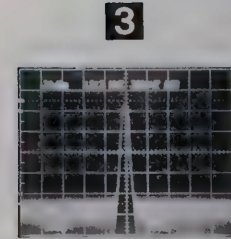

3

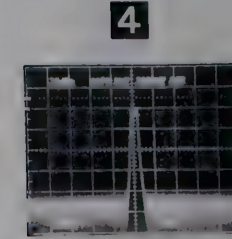

4

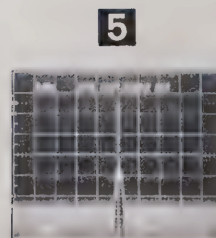

5

REC. MODE

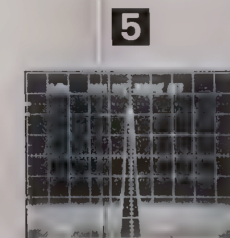

5

GEN. MODE



6

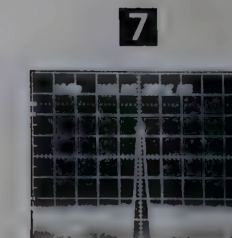

7



8

REC. MODE  
NO SIGNAL PRESENT

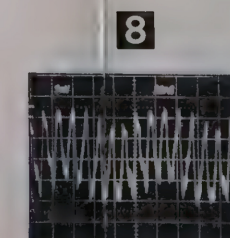

8

REC. MODE  
INPUT AT ANT  
(150.2 MHz @ -50 dB)

Figure 7-20 IF Block Assembly  
(Sheet 1 of 2)  
(0000-5111-900-H1)

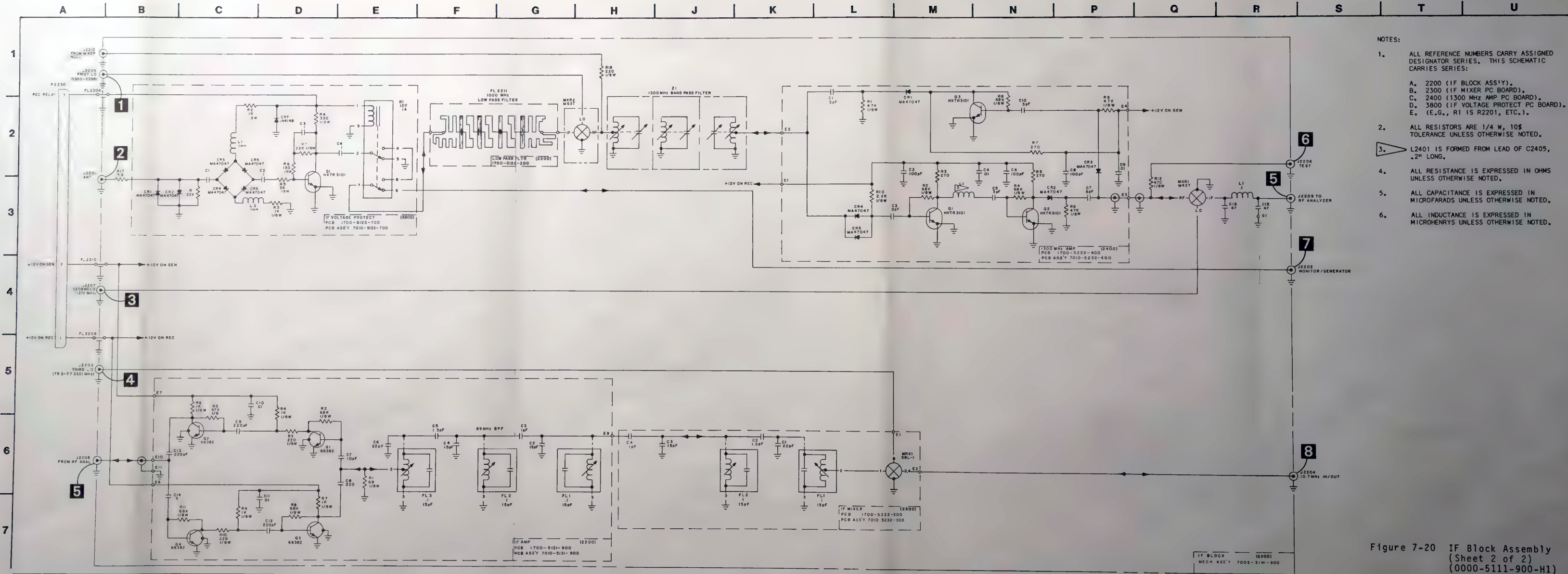

- NOTES:
- ALL REFERENCE NUMBERS CARRY ASSIGNED DESIGNATOR SERIES. THIS SCHEMATIC CARRIES SERIES:
    - A. 2200 (IF BLOCK ASS'Y).
    - B. 2300 (IF MIXER PC BOARD).
    - C. 2400 (1300 MHz AMP PC BOARD).
    - D. 3800 (IF VOLTAGE PROTECT PC BOARD).
    - E. (E.G., R1 IS R2201, ETC.).
  - ALL RESISTORS ARE 1/4 W, 10% TOLERANCE UNLESS OTHERWISE NOTED.
  - L2401 IS FORMED FROM LEAD OF C2405, .2" LONG.
  - ALL RESISTANCE IS EXPRESSED IN OHMS UNLESS OTHERWISE NOTED.
  - ALL CAPACITANCE IS EXPRESSED IN MICROFARADS UNLESS OTHERWISE NOTED.
  - ALL INDUCTANCE IS EXPRESSED IN MICROHENRYS UNLESS OTHERWISE NOTED.

Figure 7-20 IF Block Assembly (Sheet 2 of 2) (0000-5111-900-H1)

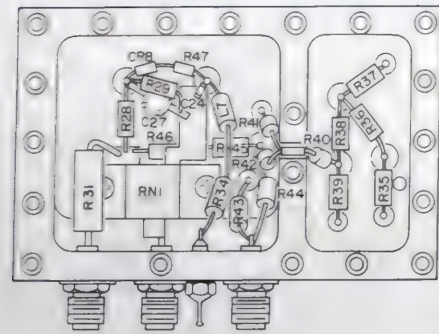

Output Amplifier Block Enclosure (Rev J)

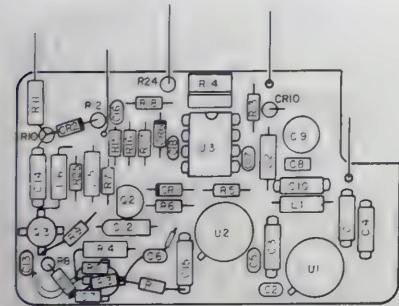

Output Amplifier PC Board (Rev C-3)

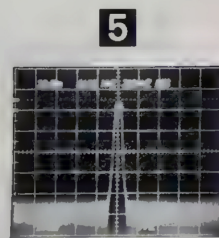
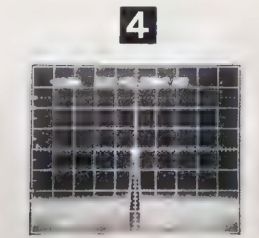
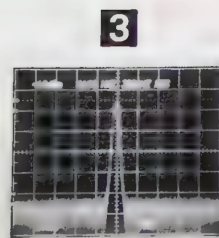
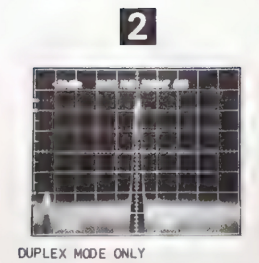
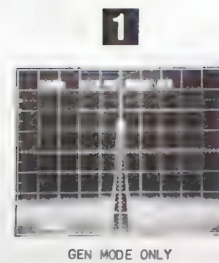

NOTE: UNLESS OTHERWISE NOTED ALL MEASUREMENTS WERE TAKEN WITH FM/AM-1200 IN GEN OR DUP GEN MODE AT A FREQUENCY OF 150.2 MHz @ -50 dBm WITH A +2 MHz OFFSET.

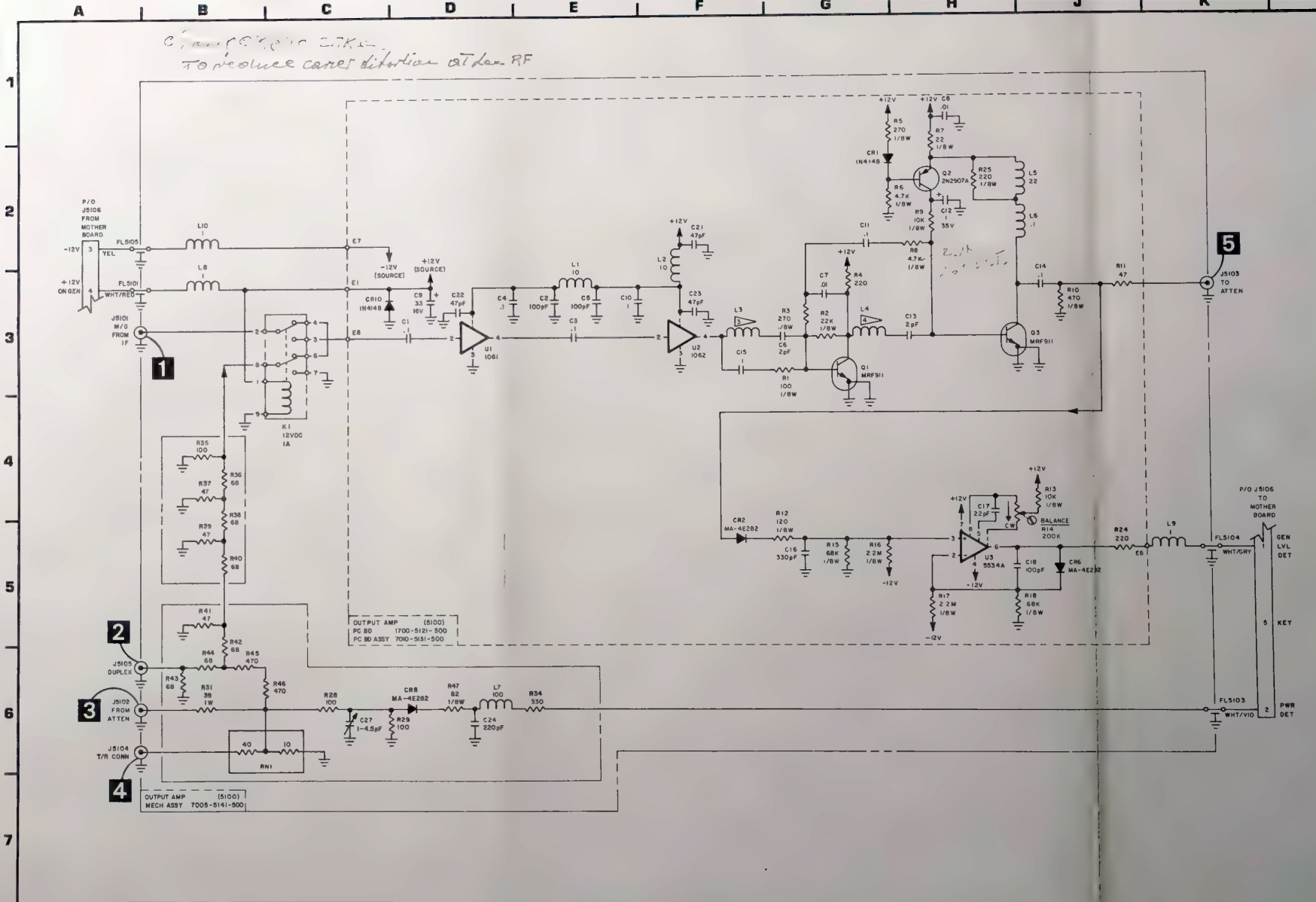

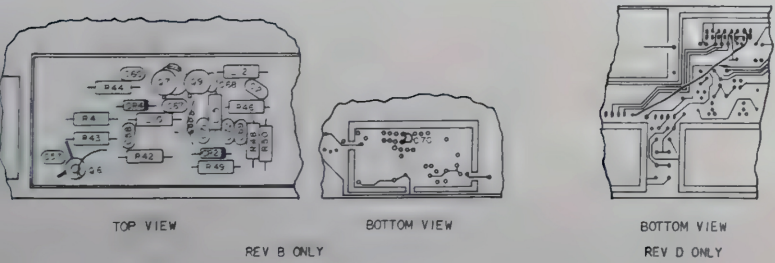
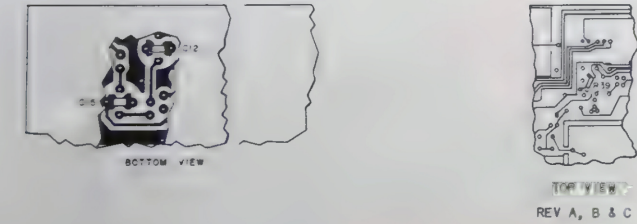
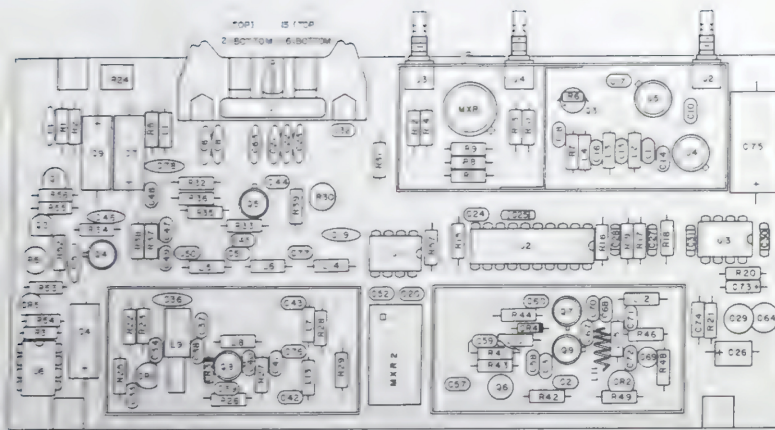

Duplex PC Board (Rev F-5)

- NOTES:
1. ALL REFERENCE NUMBERS CARRY ASSIGNED DESIGNATOR SERIES. THIS SCHEMATIC CARRIES SERIES 1200 (E.G., R1 IS R1201).
  2. ALL RESISTORS ARE 1/4 W, 5% TOLERANCE UNLESS OTHERWISE NOTED. PRECISION RESISTORS (1%) ARE DESIGNATED BY AN ASTERISK (\*).
  3. L11 IS FORMED BY A 2.4" LENGTH OF 24 GA WIRE WRAPPED 4 TURNS WITH A .125" ID.
  4. R8 IS SELECTED AT TEST (SAT). NOMINAL IS 1.8 K. RANGE IS 820 TO 2.7 K.
  5. SN1001 THRU SN1287, C70 IS 10 pF, C3 AND C60 IS 1800 pF, C59 NOT USED AND R41 IS 82 OHMS.
  6. SN1001 THRU SN1972, R18 AND R19 IS 68 K, R20 IS 1 K AND C74 IS 2.2 μf, 25 V.
  7. ALL RESISTANCE IS EXPRESSED IN OHMS UNLESS OTHERWISE NOTED.
  8. ALL CAPACITANCE IS EXPRESSED IN MICROFARADS UNLESS OTHERWISE NOTED.
  9. ALL INDUCTANCE IS EXPRESSED IN MICROHENRYS UNLESS OTHERWISE NOTED.

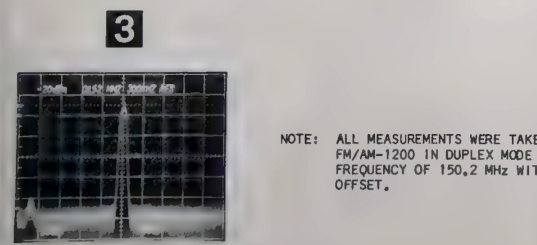
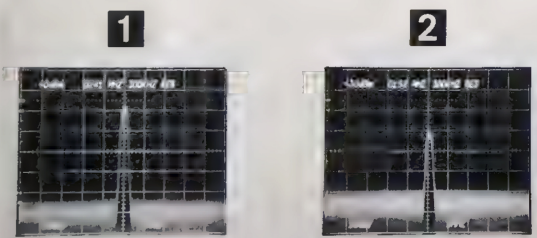

NOTE: ALL MEASUREMENTS WERE TAKEN WITH FM/AM-1200 IN DUPLEX MODE AT A FREQUENCY OF 150.2 MHz WITH +2 MHz OFFSET.

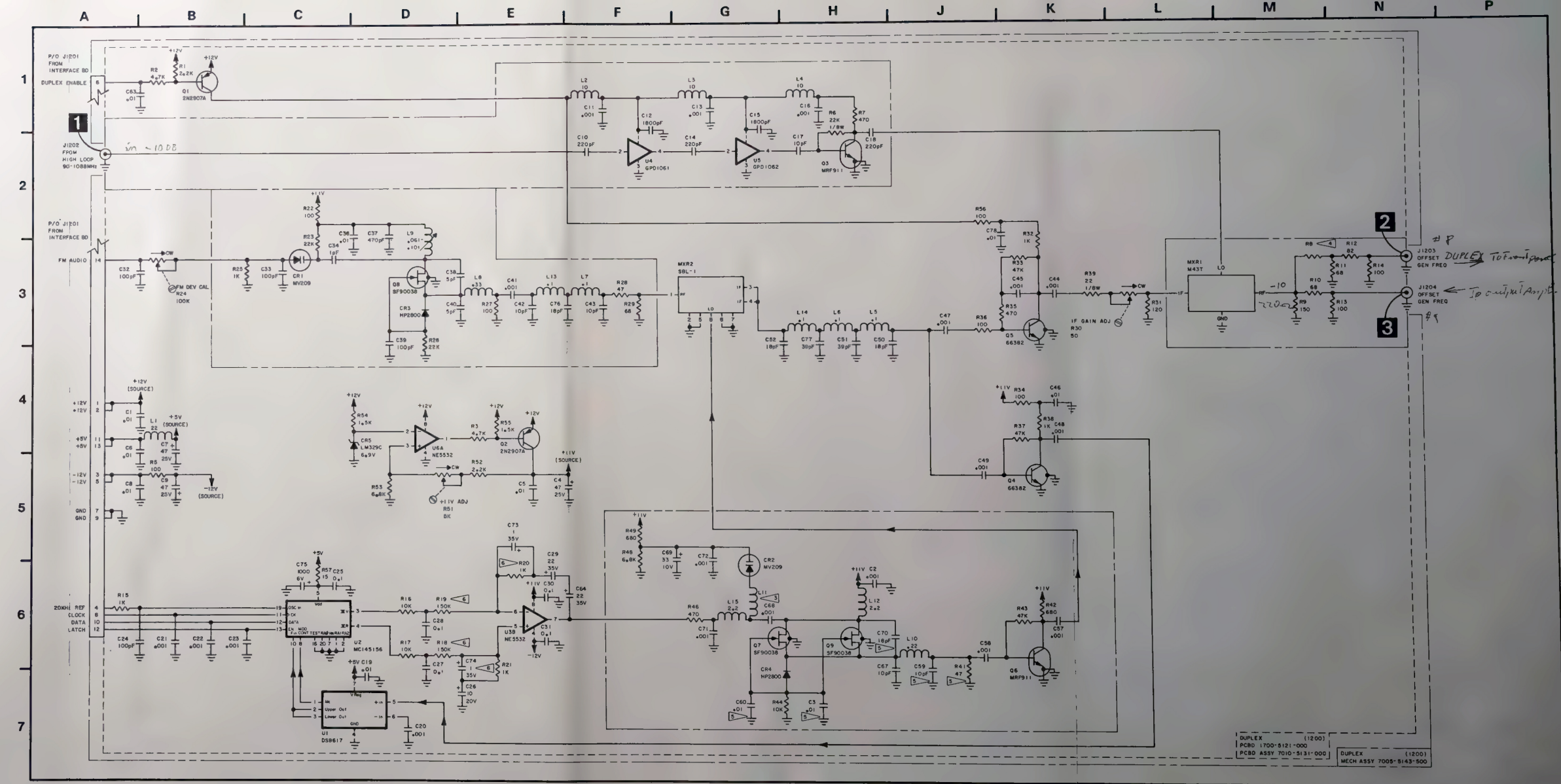

DUPLEX (1200)  
PCBD 1700-5131-000  
PCBD ASSY 7010-5131-000

DUPLEX (1200)  
MECH ASSY 7005-5143-500

Figure 7-22 Duplex Module (0000-5113-500-F5)

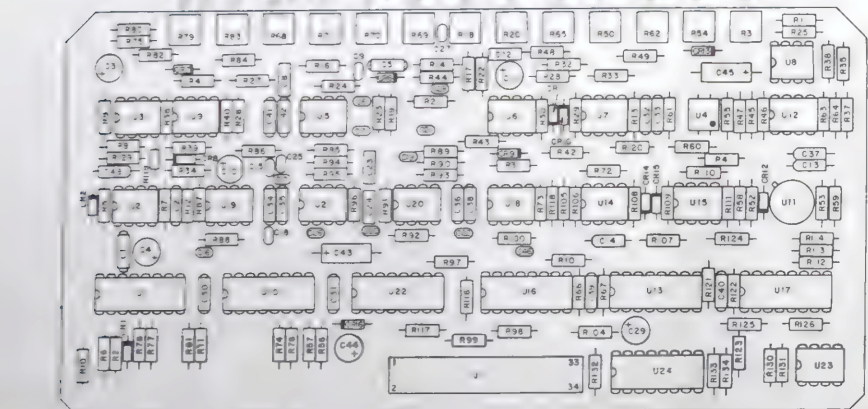

NOTES:

1. ALL REFERENCE NUMBERS CARRY ASSIGNED DESIGNATOR SERIES. THIS SCHEMATIC CARRIES SERIES 3300 AND 3400 (E.G., R1 IS R3301 AND R101 IS R3401).
2. ALL RESISTORS ARE 1/4 W, 5% TOLERANCE UNLESS OTHERWISE NOTED.
3. ALL RESISTANCE IS EXPRESSED IN OHMS UNLESS OTHERWISE NOTED.
4. ALL CAPACITANCE IS EXPRESSED IN MICROFARADS UNLESS OTHERWISE NOTED.
5. ALL INDUCTANCE IS EXPRESSED IN MICROHENRYS UNLESS OTHERWISE NOTED.

Receive Audio PC Board (Rev E)

METER SELECT CODING												
3300 3301 MOD MTR 1ST FCTN METER CONTROL POSITION												
PCB #	SENSE	FEED	A	25	AS	TEST	SYS	D	S	SINAD	150	15
19	MOD MTR A	0	0	0	0	0	0	0	0	0	0	0
21	MOD MTR B	0	1	1	0	0	0	0	0	0	0	0
22	MOD MTR C	0	0	0	0	0	0	0	0	0	0	0
28	ONE FUNCTION	0	0	0	0	0	0	0	0	0	0	0
30	AYS/PEAK	0	0	0	0	0	0	0	0	0	0	0

1 = +12 VDC    0 = 0 VDC

33301	REMARKS
PIN 3	+5 VDC WHEN FUNCTION GENERATOR IS SET ON ANY TONE BELOW 409.6 Hz
PIN 8	+12 VDC ON SSB AND ALL AM MODES
PIN 12	+12 VDC ON FM WIDE ONLY

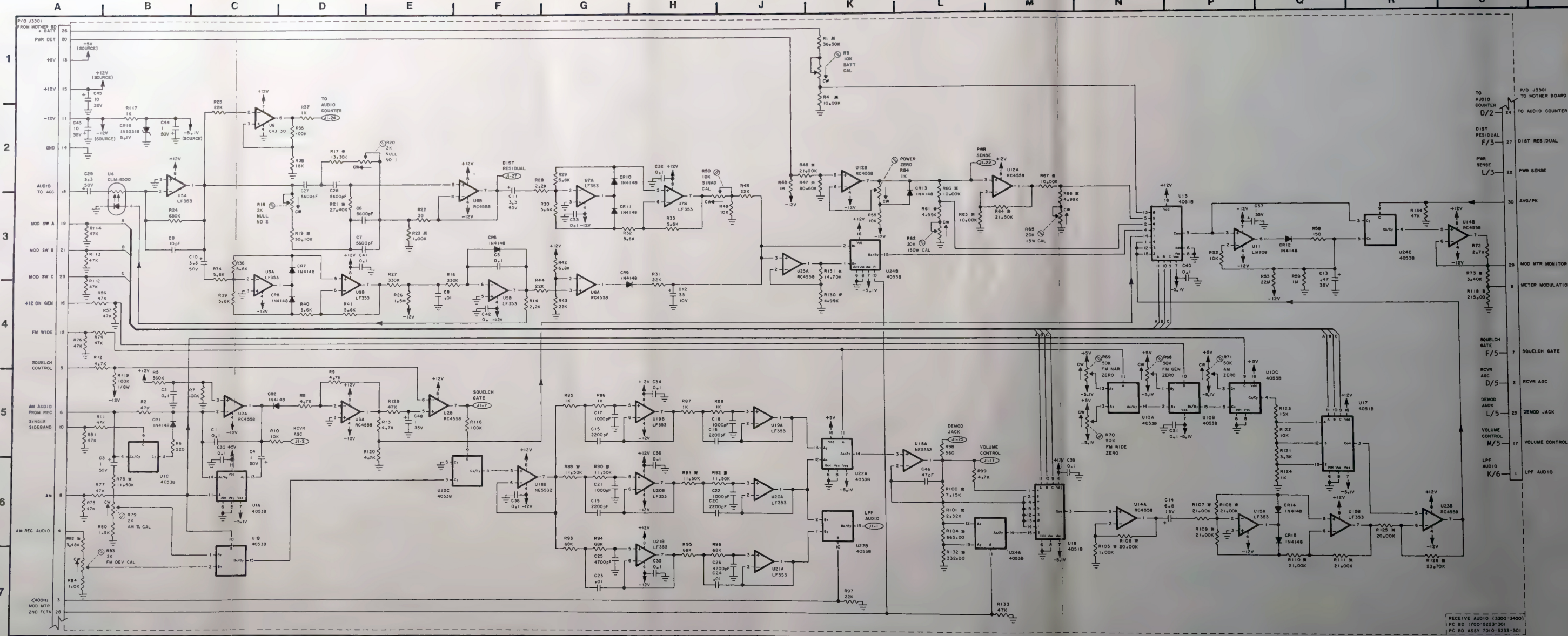
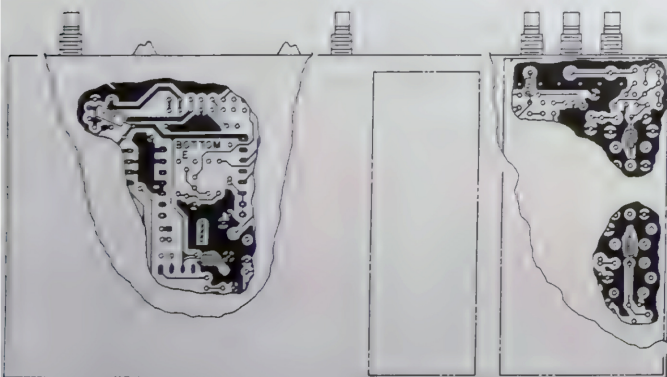
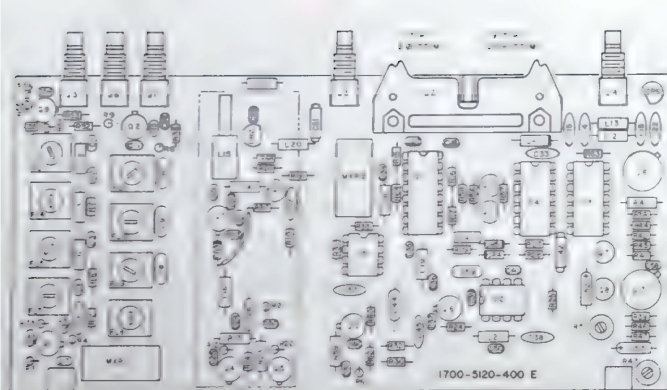
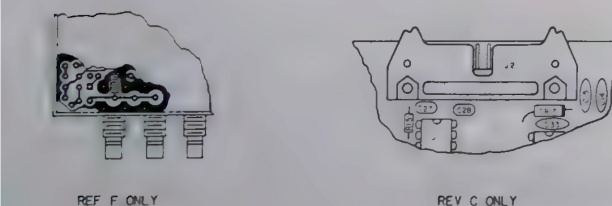

Figure 7-23 Receive Audio PC Board Assembly (0000-5213-301-D1)



BOTTOM VIEW REV C ONLY



REF F ONLY

REV C ONLY

Analyzer RF PC Board (Rev F-2)

NOTES:

- ALL REFERENCE NUMBERS CARRY ASSIGNED DESIGNATOR SERIES. THIS SCHEMATIC CARRIES SERIES 400 (E.G., R1 IS R401).
- ALL RESISTORS ARE 1/8 W, 5% TOLERANCE UNLESS OTHERWISE NOTED.
- ALL RESISTANCE IS EXPRESSED IN OHMS UNLESS OTHERWISE NOTED.
- R64 IS SELECTED AT TEST (SAT). NOMINAL IS 1.2 K. RANGE IS 1.0 K TO 2.2 K.
- SN1001 THRU SN1286, R34 IS 68Ω, R65 NOT USED, SN1287 & ON R34 IS NOT USED, AND R65 IS 56Ω.
- SN1001 THRU SN1196, C59 IS NOT USED.
- SN1001 THRU SN1747 R53 IS 10Ω, SN1748 & ON R53 IS 33Ω.
- ALL CAPACITANCE IS EXPRESSED IN MICROFARADS UNLESS OTHERWISE NOTED.
- ALL INDUCTANCE IS EXPRESSED IN MICROHENRYS UNLESS OTHERWISE NOTED.

HORIZONTAL SWEEP SELECTOR POSITION	PIN #		
	5	7	9
1 KHZ/DIV	1	0	0
2 KHZ/DIV	1	0	0
5 KHZ/DIV	0	1	0
10 KHZ/DIV	0	1	0
20 KHZ/DIV	0	1	0
50 KHZ/DIV	0	0	1
.1 MHZ/DIV	0	0	1
.2 MHZ/DIV	0	0	1
.5 MHZ/DIV	0	0	1
1 MHZ/DIV	0	0	1

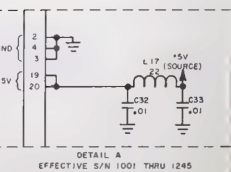

DETAIL A  
EFFECTIVE S/N 1001 THRU 1245

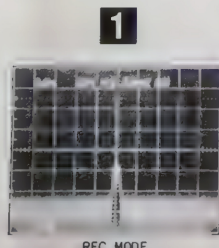

REC MODE

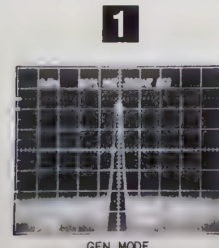

GEN MODE

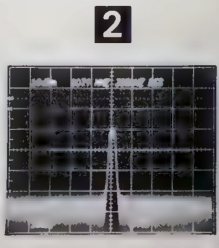

REC MODE

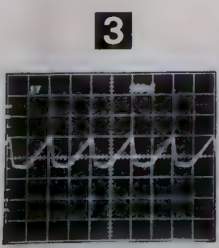

REC MODE

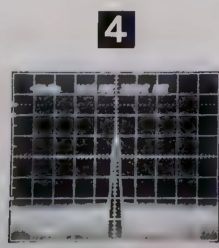

GEN MODE

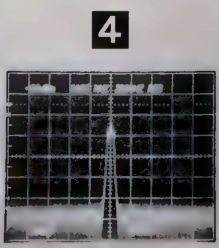

REC MODE

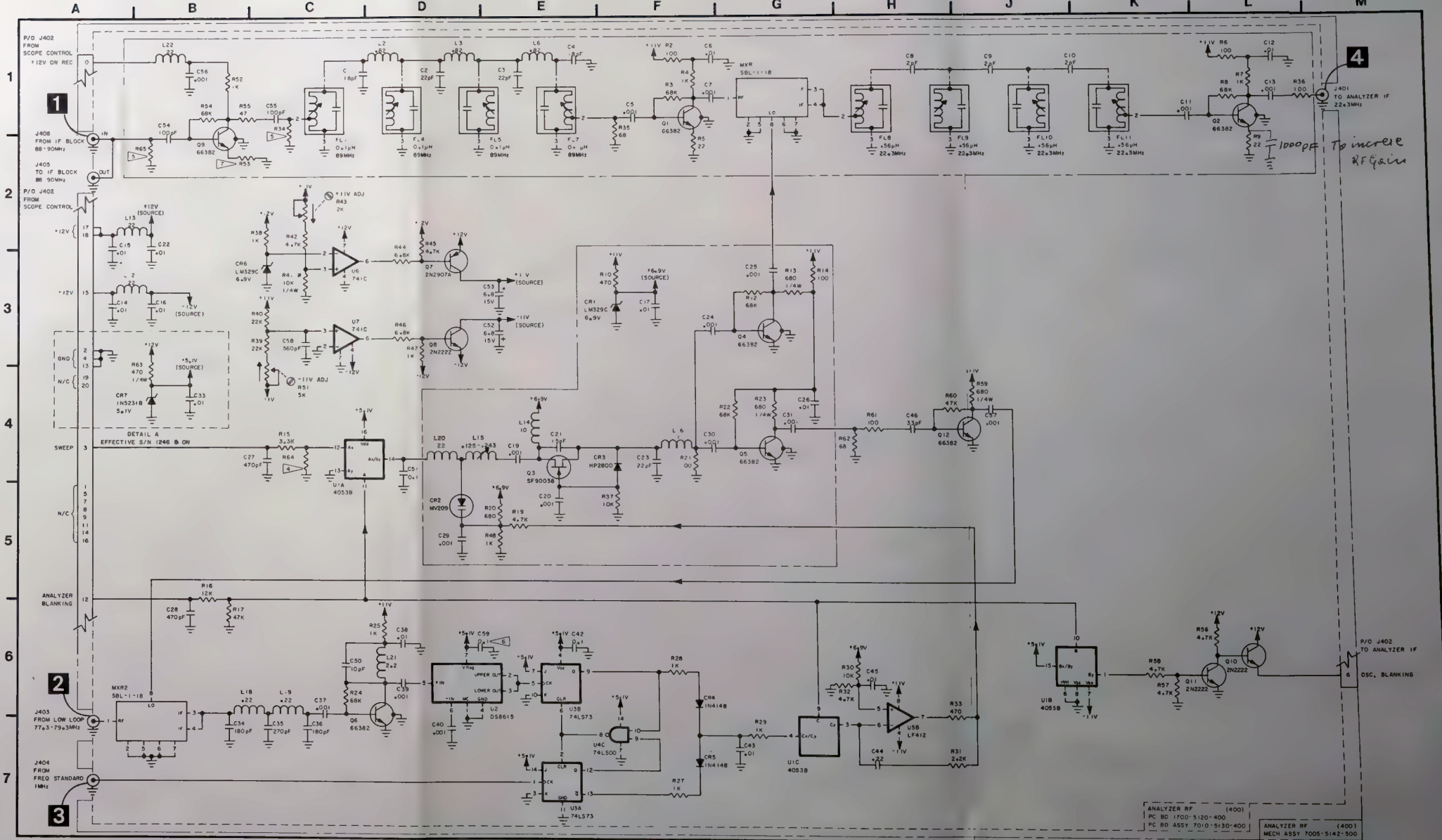
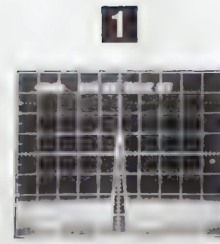

Figure 7-24 Analyzer RF Module  
(0000-5112-500-F)



REC MODE



GEN MODE

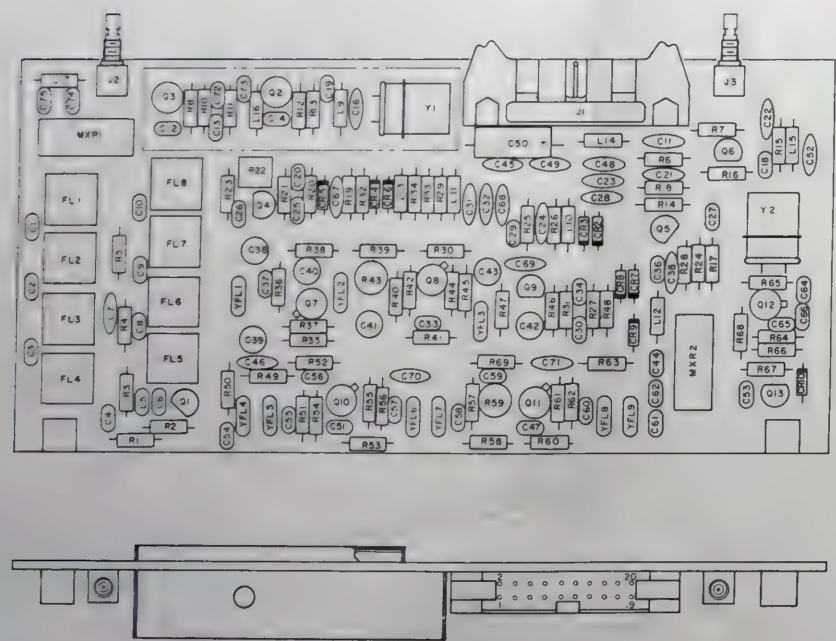

Analyzer IF PC Board (Rev D-7)

NOTES:

1. ALL REFERENCE NUMBERS CARRY ASSIGNED DESIGNATOR SERIES. THIS SCHEMATIC CARRIES SERIES 500 (E.G., R1 IS R501).
2. ALL RESISTORS ARE 1/4 W, 5% TOLERANCE UNLESS OTHERWISE NOTED.
3. SN1001 THRU SN1195, R42 IS 1 K, 1/4 W, 5% TOLERANCE.
4. SN1001 THRU SN1872, Q1, Q4, Q5, Q6, Q9 AND Q13 ARE 66382 TRANSISTORS. R50 IS 100Ω, 1/4 W, 5% TOLERANCE AND R54 IS 1 K, 1/4 W, 5% TOLERANCE.
5. ALL RESISTANCE IS EXPRESSED IN OHMS UNLESS OTHERWISE NOTED.
6. ALL CAPACITANCE IS EXPRESSED IN MICROFARADS UNLESS OTHERWISE NOTED.
7. ALL INDUCTANCE IS EXPRESSED IN MICROHENRYS UNLESS OTHERWISE NOTED.

HORIZONTAL SWEEP SELECTOR POSITION	PIN #		
	5	7	9
1 kHz/DIV	1	0	0
2 kHz/DIV	1	0	0
5 kHz/DIV	0	1	0
10 kHz/DIV	0	1	0
20 kHz/DIV	0	1	0
50 kHz/DIV	0	0	1
.1 MHz/DIV	0	0	1
.2 MHz/DIV	0	0	1
.5 MHz/DIV	0	0	1
1 MHz/DIV	0	0	1
1 = +12 VDC 0 = 0 VDC			

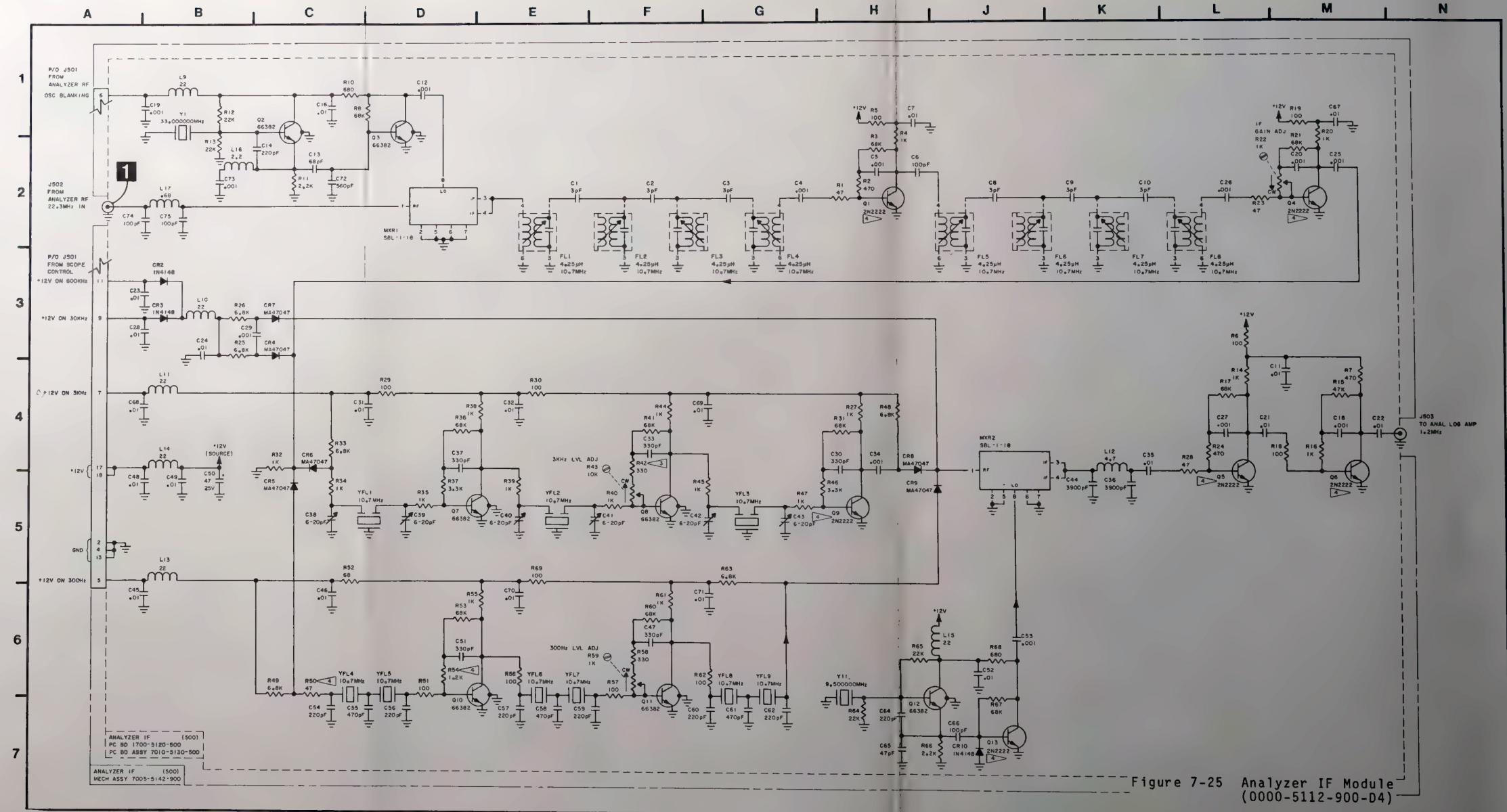
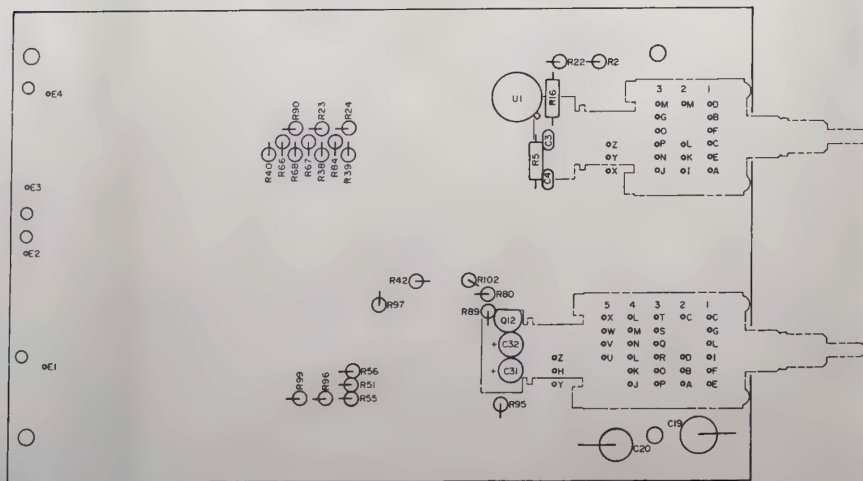
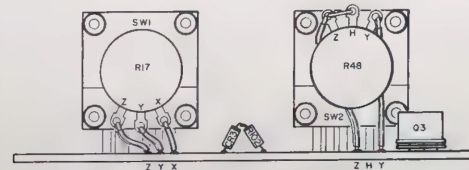
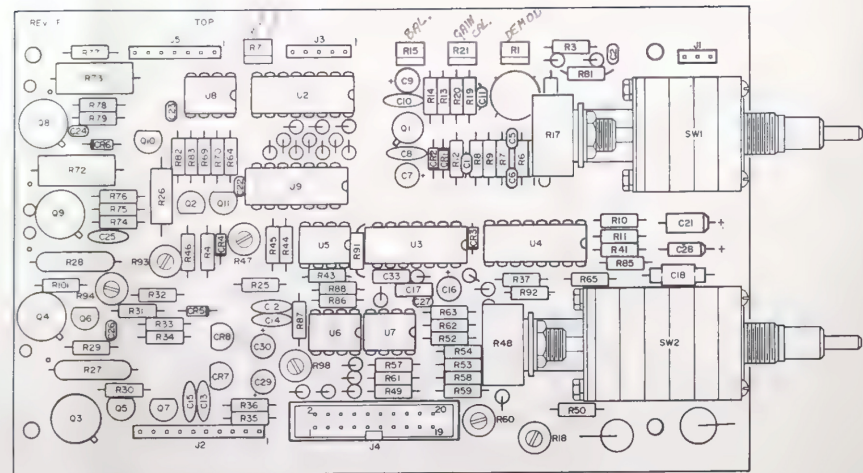
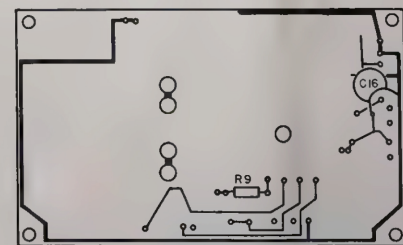
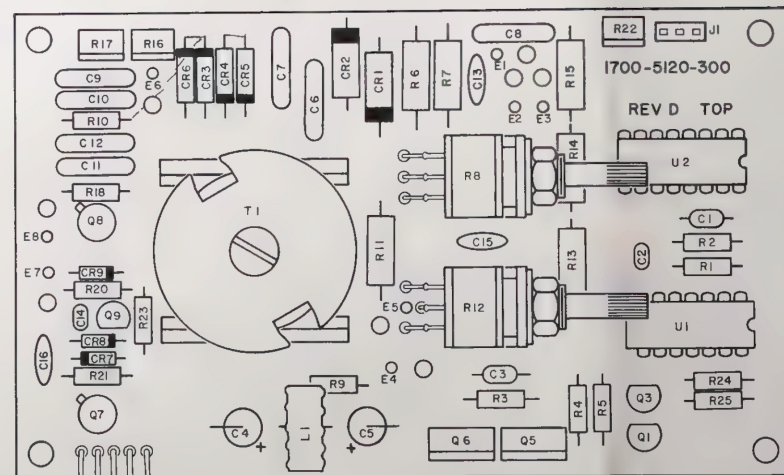

Figure 7-25 Analyzer IF Module (0000-5112-900-04)



Scope Control PC Board (Rev F-4)



Scope Power PC Board (Rev D-6)

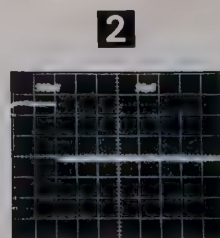
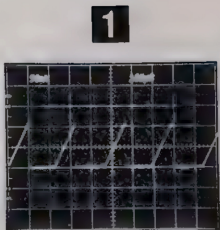

NOTE: ALL MEASUREMENTS WERE TAKEN WITH NO SIGNAL PRESENT. FM/AM-1200 SETTINGS: .01 mS/DIV, SQUELCH FULLY CW.

VERTICAL ATTENUATOR SELECTOR CONTROL (S201) TRUTH TABLE

VERTICAL ATTENUATOR SELECTOR POSITION	PINS SHORTED		
	SECTION 1	SECTION 2	SECTION 3
kHz/ÅX10			
OFF			P-Q
.5	D-B	M-I	
.2	D-A	M-I	
5	B-E		M-J
20	E-A		M-J
V/DIV			
10	F-C	M-L	P-G
1	F-C	M-K	P-G
.1	C-E		M-J P-G
.01	D-C	M-I	P-G
RESID			M-N P-G

HORIZONTAL SWEEP SELECTOR CONTROL (S202) TRUTH TABLE

HORIZONTAL SWEEP SELECTOR POSITION	PINS SHORTED				
	SECTION 1	SECTION 2	SECTION 3	SECTION 4*	SECTION 5
TONES	C-F		T-P, R-Q		
mS/DIV					
10		C-A	T-O, R-Q		
1		C-B	T-O, R-Q		
.1		C-D	T-O, R-Q		
.01	C-E		T-O, R-Q		
Hz/DIV					
1	C-G		R-S		U-V
.5	C-G, L-I		R-S		U-V
.2	C-G		R-S	L-J	U-V
.1	C-G		R-S	L-K	U-V
Hz/DIV					
50	C-G, L-I		R-S	L-M	U-V
20	C-G		R-S	L-J, L-M	U-W
10	C-G		R-S	L-K, L-M	U-W
5	C-G, L-I		R-S	L-N	U-W
2		C-A	R-S	L-J, L-N	U-X
1		C-A	R-S	L-K, L-N	U-X

\* SECTION 4 CONTAINS TWO "L" PINS WHICH ARE TIED TO GROUND

Figure 7-26 Scope Power and Control Assembly (Sheet 1 of 3) (0000-5110-200-F2) (0000-5110-300-D1)

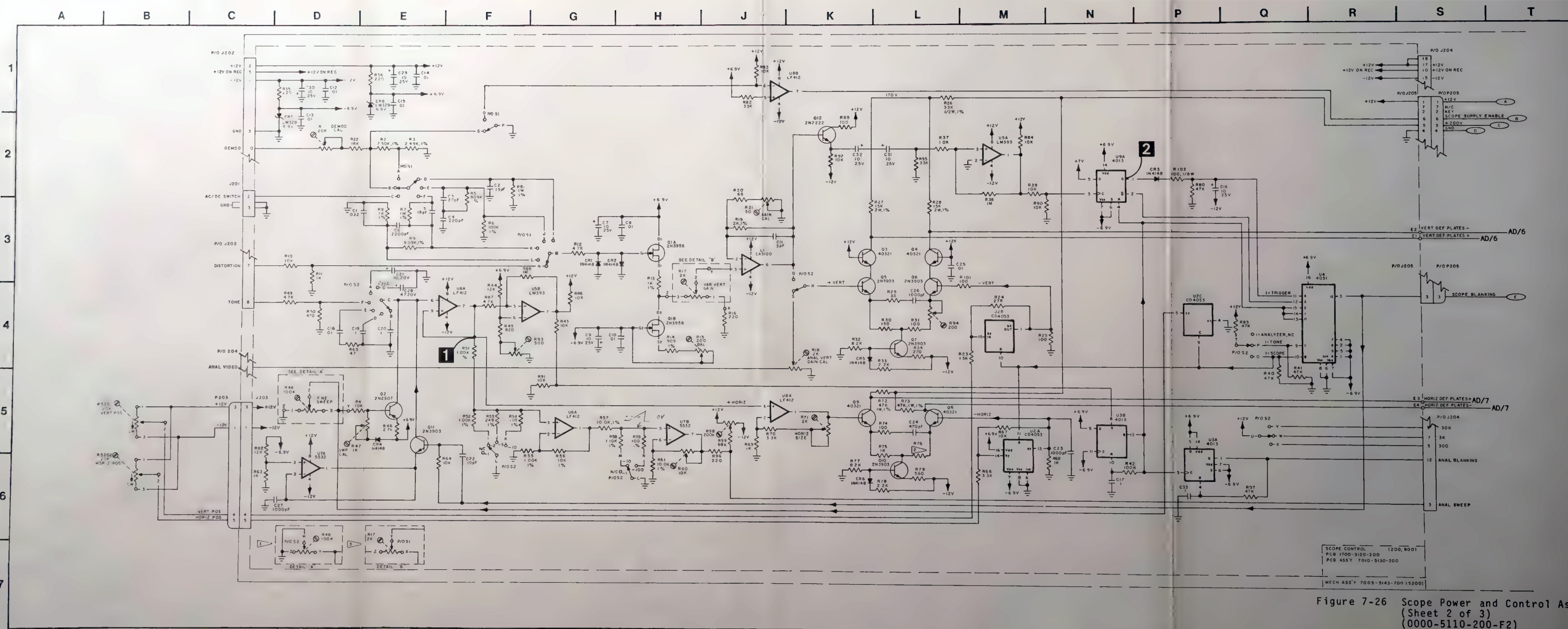
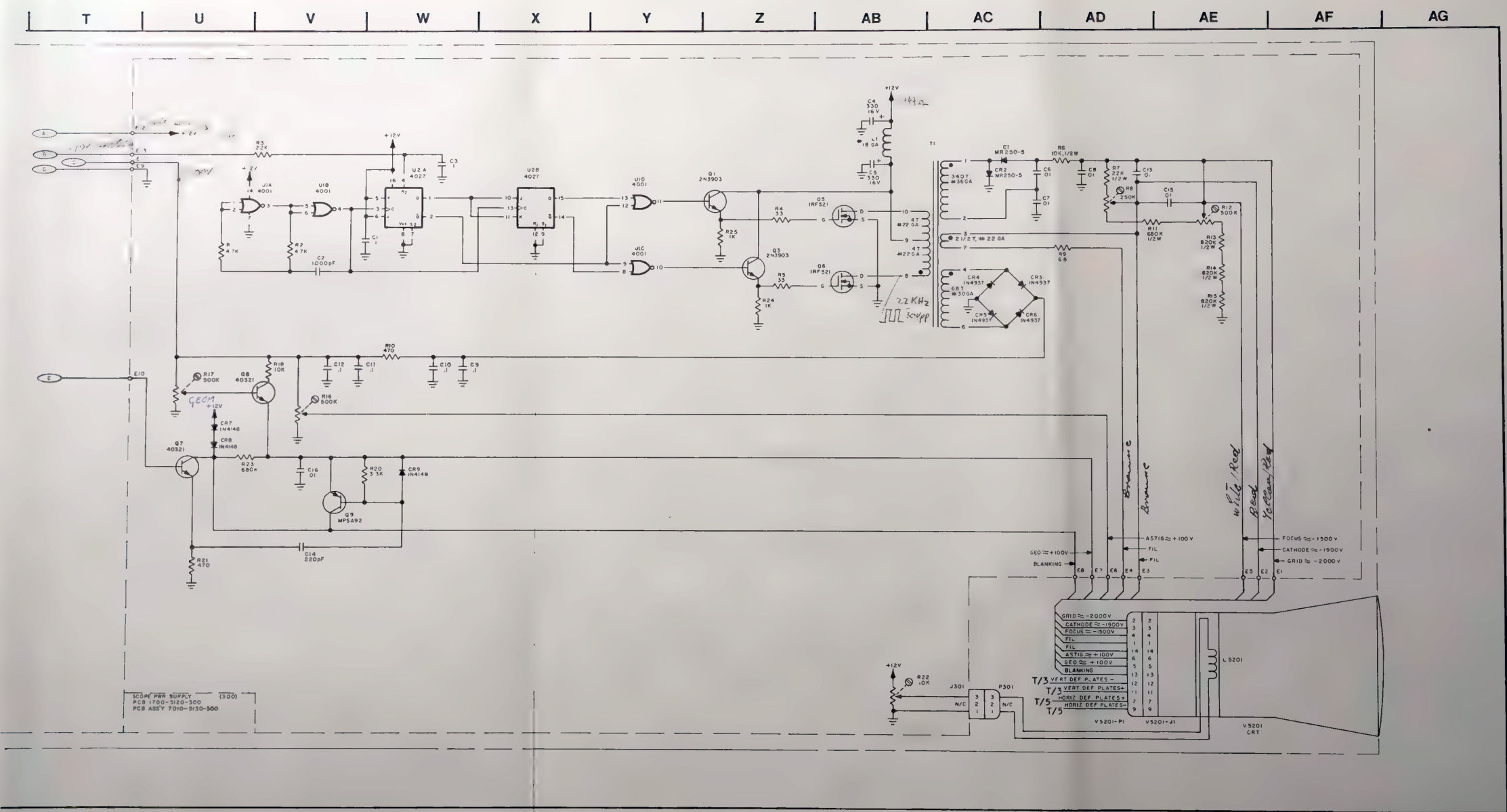
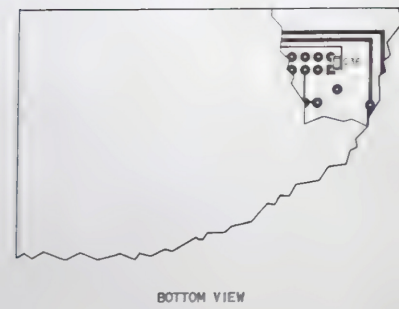

Figure 7-26 Scope Power and Control Assembly  
 (Sheet 2 of 3)  
 (0000-5110-200-F2)  
 (0000-5110-300-D1)



- STANDARDS:
- ALL REFERENCE NUMBERS CARRY ASSIGNED DESIGNATOR SERIES. THIS SCHEMATIC CARRIES SERIES:
    - A. 200, 900 (SCOPE CONTROL PC BOARD).
    - B. 300 (SCOPE POWER SUPPLY PC BOARD).
    - C. 5200 (MECHANICAL ASS'Y).
    - D. (E.G., R1 IS R201, ETC.)
  - ALL RESISTORS ARE 1/4 W, 5% TOLERANCE UNLESS OTHERWISE NOTED.
  - ALL RESISTANCE IS EXPRESSED IN OHMS UNLESS OTHERWISE NOTED.
  - ALL CAPACITANCE IS EXPRESSED IN MICROFARADS UNLESS OTHERWISE NOTED.
  - ALL INDUCTANCE IS EXPRESSED IN MICROHENRYS UNLESS OTHERWISE NOTED.
- NOTES: (SCOPE CONTROL PC BOARD)
- NOT USED.
  - R76 IS SELECTED AT TEST (SAT). NOMINAL IS 1 K. RANGE IS 800Ω TO 1.2 K.
  - THESE DETAILS ARE EFFECTIVE THROUGH SNI378.

Figure 7-26 Scope Power and Control Assembly  
 (Sheet 3 of 3)  
 (0000-5110-200-F2)  
 (0000-5110-300-D1)



HORIZONTAL SWEEP SELECTOR POSITION	PIN #		
1 kHz/DIV	1	0	0
2 kHz/DIV	1	0	0
5 kHz/DIV	0	1	0
10 kHz/DIV	0	1	0
20 kHz/DIV	0	1	0
50 kHz/DIV	0	0	1
1 MHz/DIV	0	0	1
2 MHz/DIV	0	0	1
5 MHz/DIV	0	0	1
1 MHz/DIV	0	0	1
	1 = +12 VDC	0 = 0 VDC	

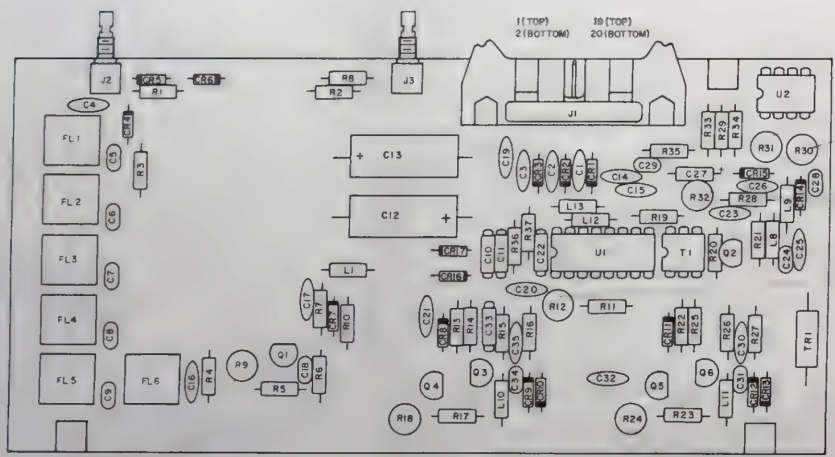

Analyzer Log Amplifier PC Board (Rev B-7)

NOTES:

- ALL REFERENCE NUMBERS CARRY ASSIGNED DESIGNATOR SERIES. THIS SCHEMATIC CARRIES SERIES 800 (E.G., R1 IS R801).
- ALL RESISTORS ARE 1/4 W, 5% TOLERANCE UNLESS OTHERWISE NOTED. PRECISION RESISTORS (1%) ARE DESIGNATED BY AN ASTERISK (\*).
- ALL RESISTANCE IS EXPRESSED IN OHMS UNLESS OTHERWISE NOTED.
- SN1001 THRU SN1872, Q1 IS A 66382 WITH CASE GROUNDING.
- R21 IS SELECT AT TEST (SAT). NOMINAL IS 1.8 K. RANGE IS 1.0 K TO 3.3 K.
- ALL CAPACITANCE IS EXPRESSED IN MICROFARADS UNLESS OTHERWISE NOTED.
- ALL INDUCTANCE IS EXPRESSED IN MICROHENRYS UNLESS OTHERWISE NOTED.

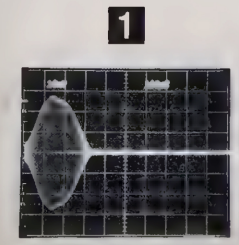

NOTE: MEASUREMENT WAS TAKEN WITH AN INPUT AT THE ANT OF 150.2 MHz @ -50 dBm USING AN X10 PROBE, FM/AM-1200 SETTING IS 1 MHz/DIV.

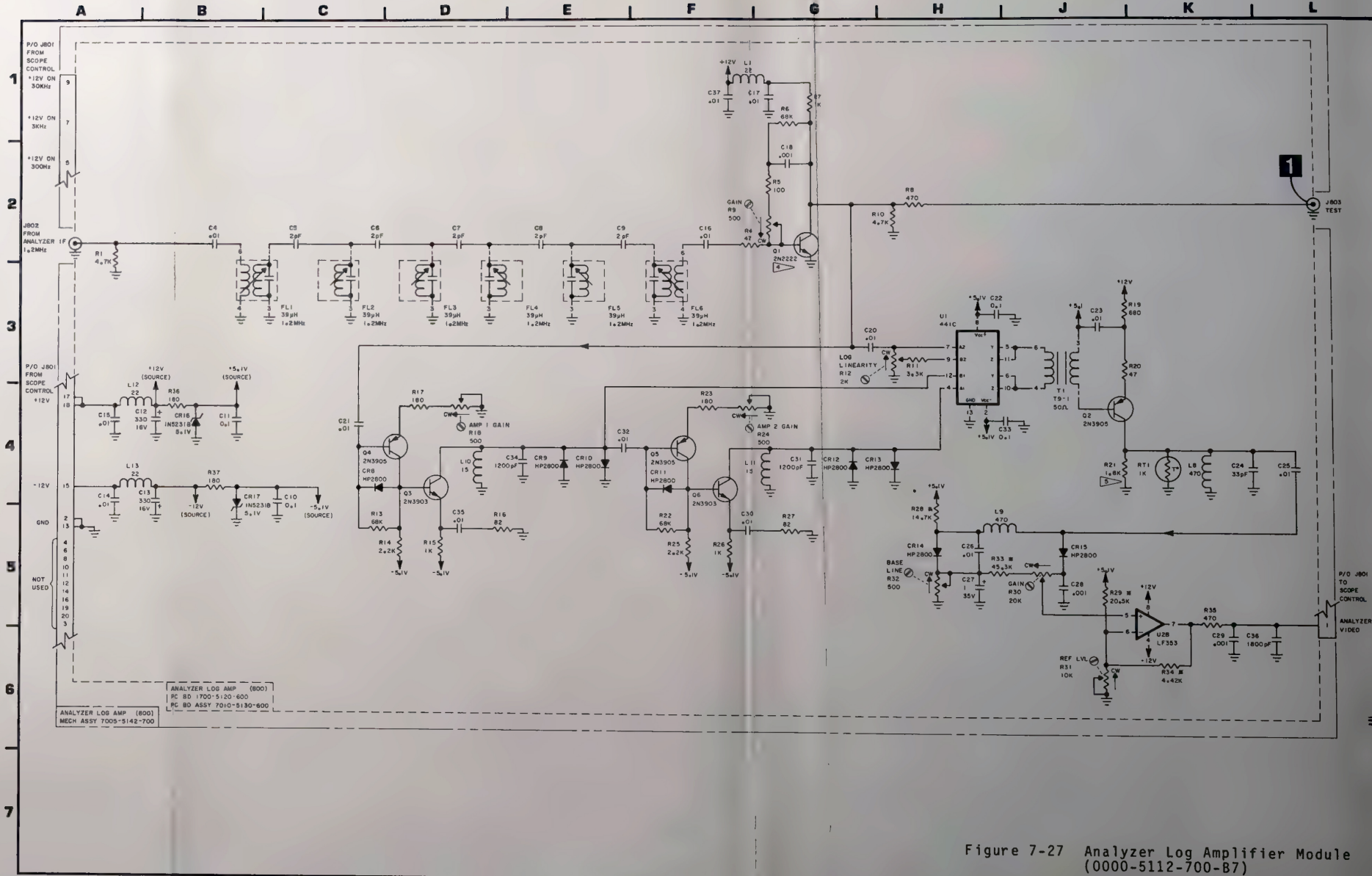
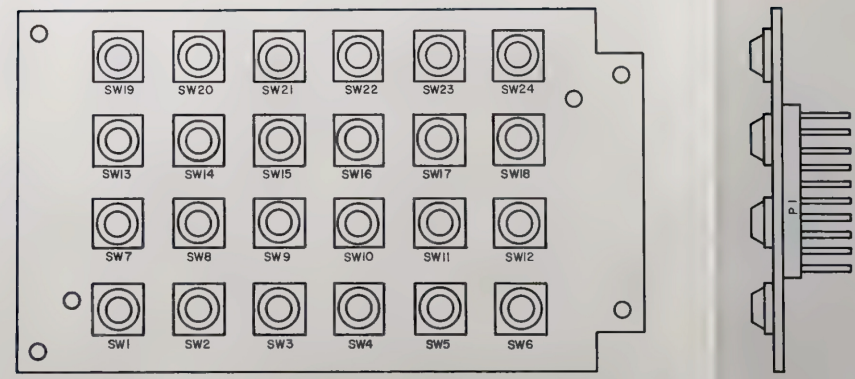

Figure 7-27 Analyzer Log Amplifier Module (0000-5112-700-B7)



Keyboard PC Board (Rev E-3)

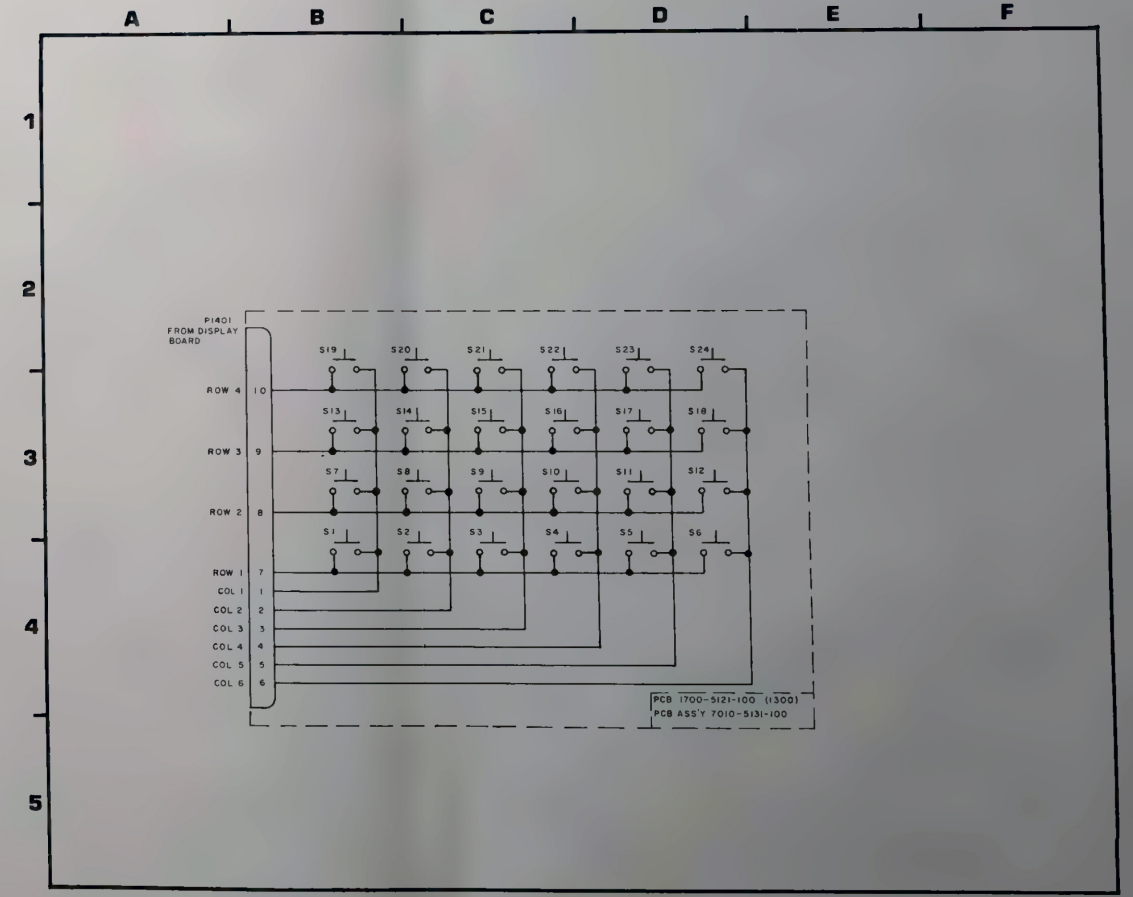
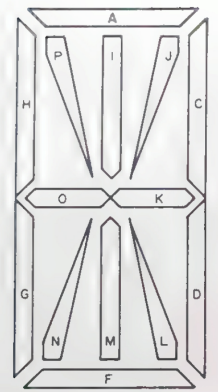
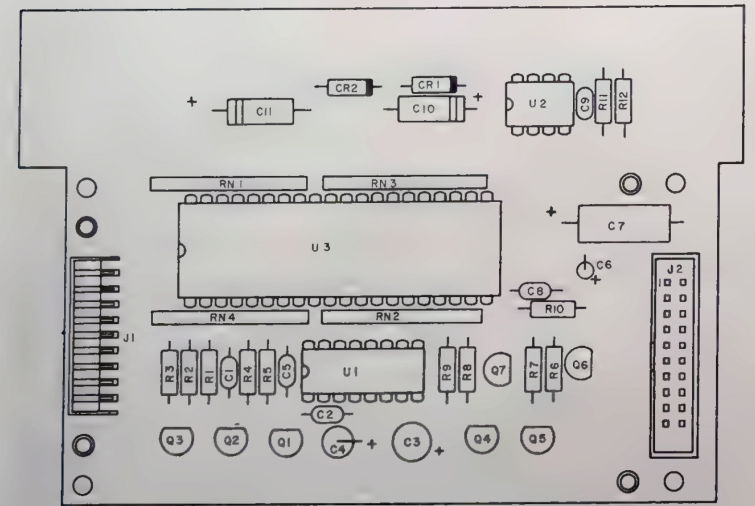

Figure 7-28 Keyboard Assembly (0000-5111-100-A)



VFD DISPLAY WITH SEGMENT LOCATIONS IDENTIFIED (A THRU P)

- NOTES:
1. ALL REFERENCE NUMBERS CARRY ASSIGNED DESIGNATOR SERIES. THIS SCHEMATIC CARRIES SERIES 1400 (E.G., R1 IS R1401).
  2. ALL RESISTORS ARE 1/4 W, 5% TOLERANCE UNLESS OTHERWISE NOTED.
  3. ALL RESISTANCE IS EXPRESSED IN OHMS UNLESS OTHERWISE NOTED.
  4. ALL CAPACITANCE IS EXPRESSED IN MICROFARADS UNLESS OTHERWISE NOTED.
  5. ALL INDUCTANCE IS EXPRESSED IN MICROHENRYS UNLESS OTHERWISE NOTED.



Display PC Board (Rev D-4)

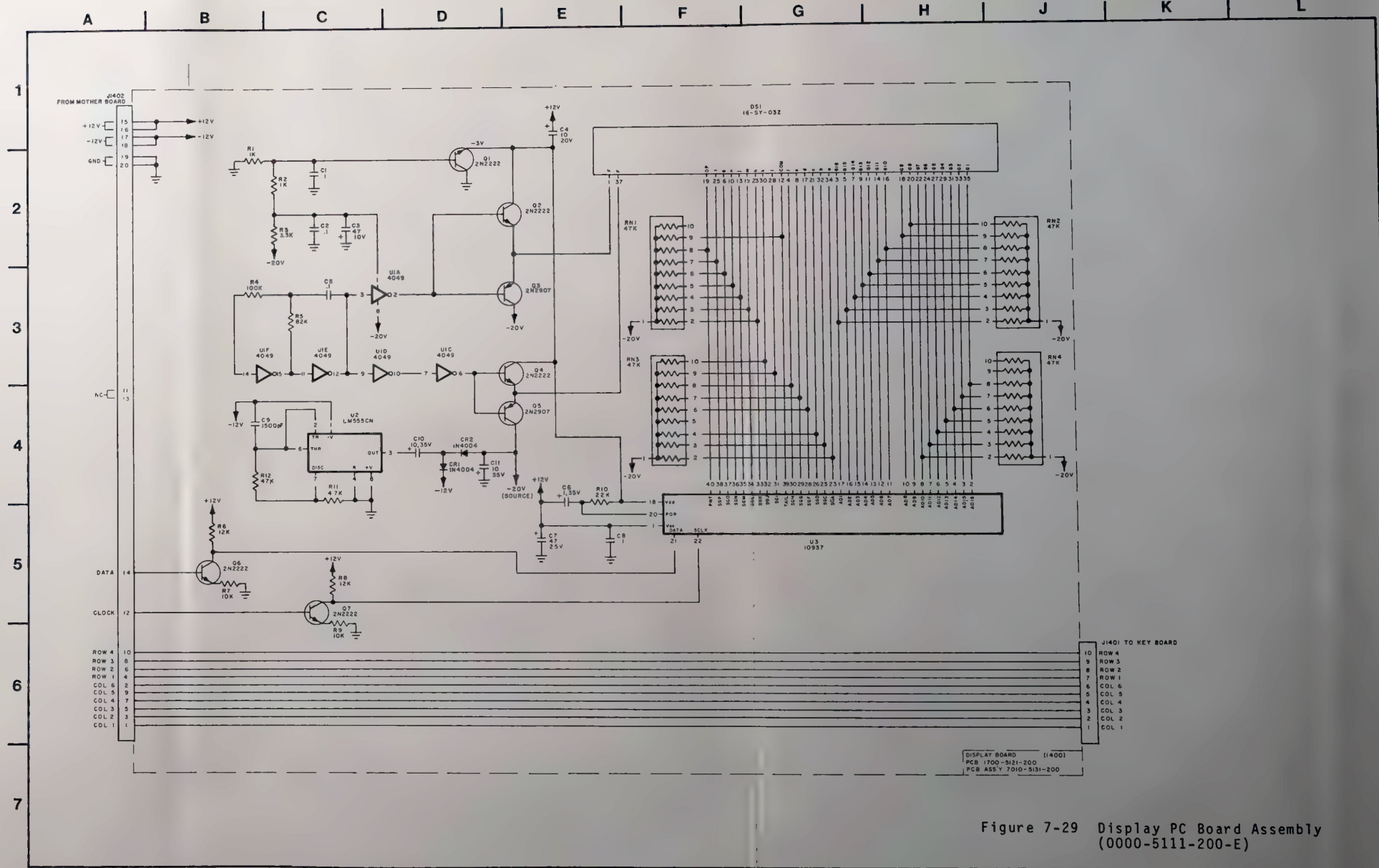
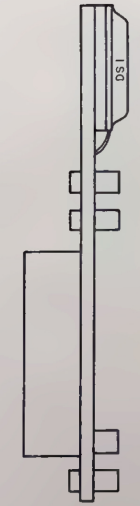
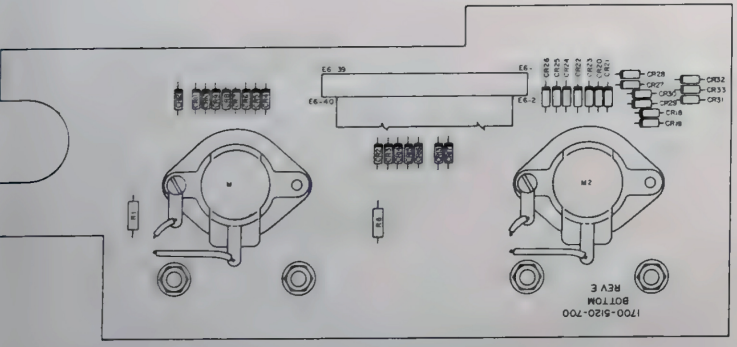
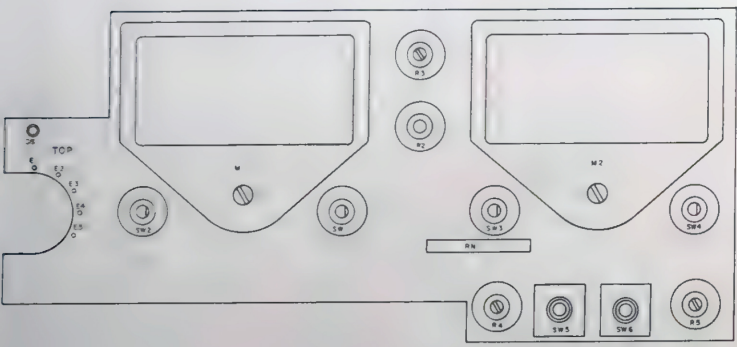

Figure 7-29 Display PC Board Assembly (0000-5111-200-E)



Display PC Board (Rev D-4)

S3701 MODE SELECTOR CONTROL		
POSITION	CONTROL LINES	
	MODE A	MODE B
GEN	0	0
REC	1	0
DUP	0	1
DUP/GEN	1	1
1 = +5 VDC 0 = 0 VDC		

S3703 MODULATION SELECT CONTROL						
POSITION	CONTROL LINES					
	AM	SSB	FM WIDE	6K	15K	200K
AM NORM	1	0	0	0	1	0
AM NAR	1	0	0	1	0	0
SSB	1	1	0	1	0	0
FM NAR	0	0	0	0	1	0
FM MID	0	0	0	0	0	1
FM WIDE	1	0	1	0	0	1
1 = +12 VDC 0 = 0 VDC						

S3702 FREQ ERROR METER RANGE SELECTOR CONTROL				
POSITION	CONTROL LINES			
	FREQ MTR A	FREQ MTR B	FREQ MTR C	FREQ MTR D
30	0	0	0	0
100	1	0	0	0
300	0	1	0	0
1K	1	1	0	0
3K	0	0	1	0
10K	1	0	1	0
AUDIO				
3	0	1	1	0
30	1	1	1	0
300	0	0	0	1
1 = +5 VDC 0 = 0 VDC				

S3704 MODULATION METER CONTROL				
POSITION	CONTROL LINES			
	MOD MTR A	MOD MTR B	MOD MTR C	MOD MTR D
MP 150	0	0	0	0
MP 15	1	0	0	0
MA 150	0	1	0	0
MA 15	1	1	0	0
2 kHz/\$X10	0	0	1	0
6 kHz/\$X10	1	0	1	0
20 kHz/\$X10	0	1	1	0
60 kHz/\$X10	1	1	1	0
BATT	0	0	0	1
SIG	1	0	0	1
DIST	0	1	0	1
SINAD	1	1	0	1
1 = +5 VDC 0 = 0 VDC				

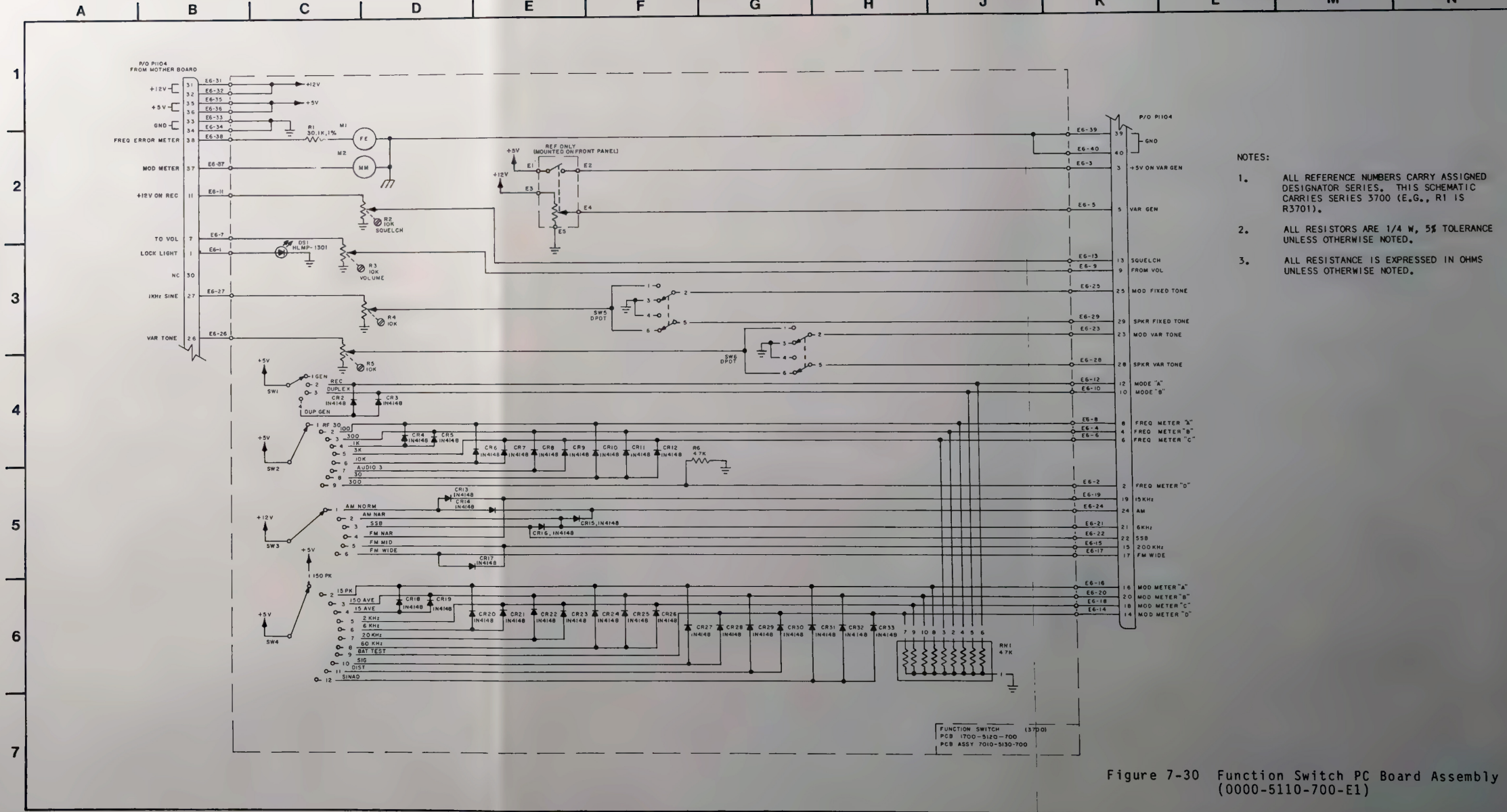
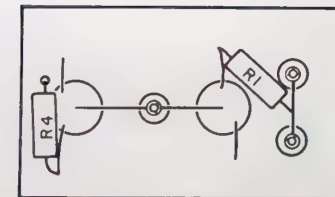
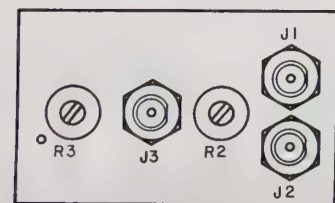

Figure 7-30 Function Switch PC Board Assembly (0000-5110-700-E1)



TOP VIEW



BOTTOM VIEW

Null Mixer PC Board (Rev A)

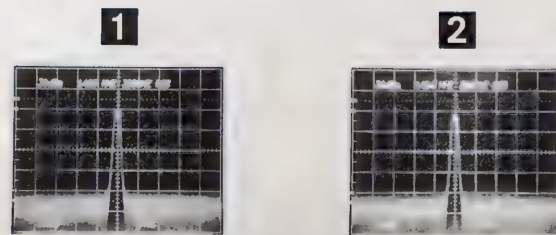

NOTE: MEASUREMENTS WERE TAKEN IN GEN MODE AT A FREQUENCY OF 150.2 MHz.

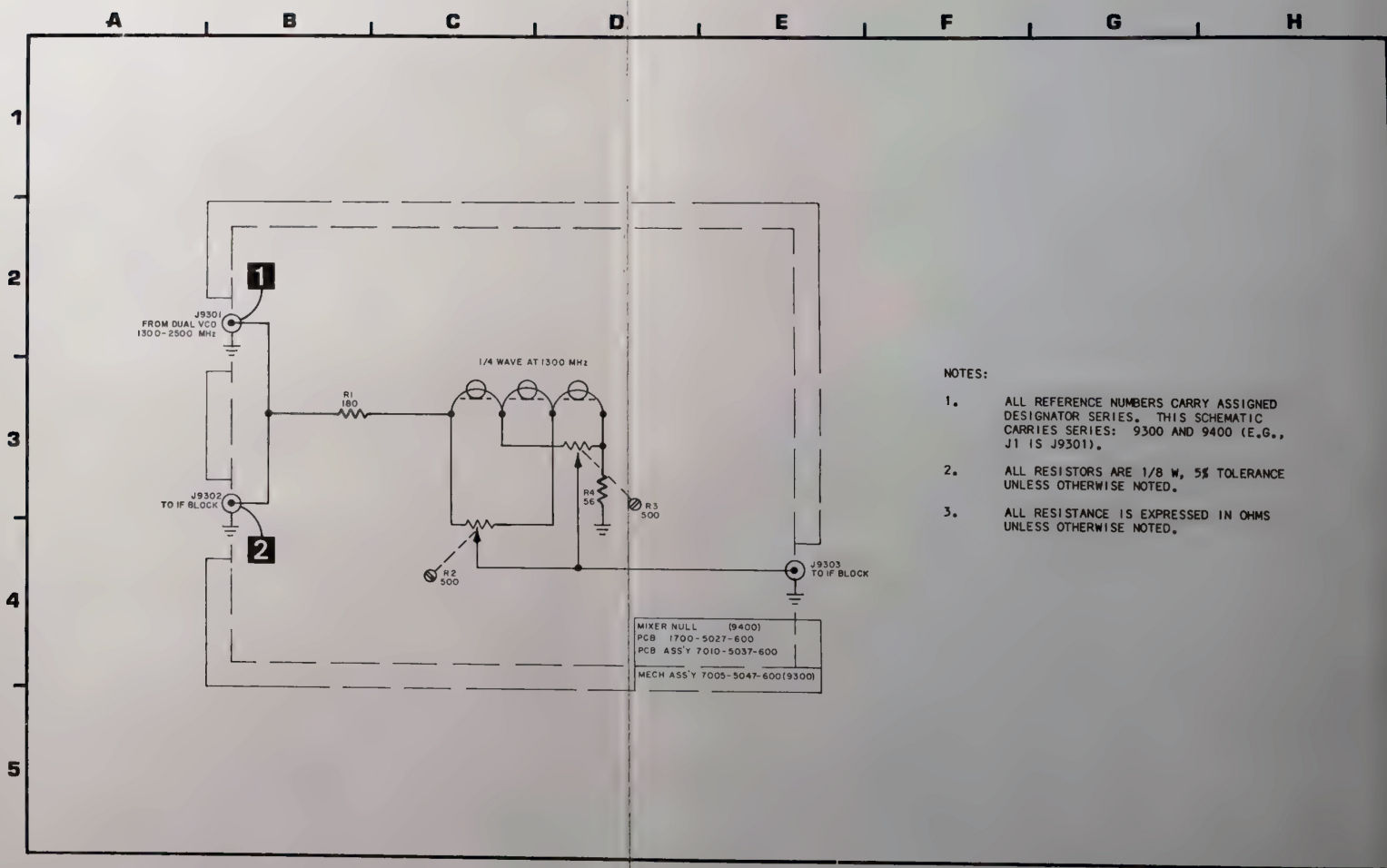

NOTES:

1. ALL REFERENCE NUMBERS CARRY ASSIGNED DESIGNATOR SERIES. THIS SCHEMATIC CARRIES SERIES: 9300 AND 9400 (E.G., J1 IS J9301).
2. ALL RESISTORS ARE 1/8 W, 5% TOLERANCE UNLESS OTHERWISE NOTED.
3. ALL RESISTANCE IS EXPRESSED IN OHMS UNLESS OTHERWISE NOTED.

Figure 7-31 Null Mixer Assembly (0000-5114-700-A)



Generate Amplifier PC Board (Rev P-1B)

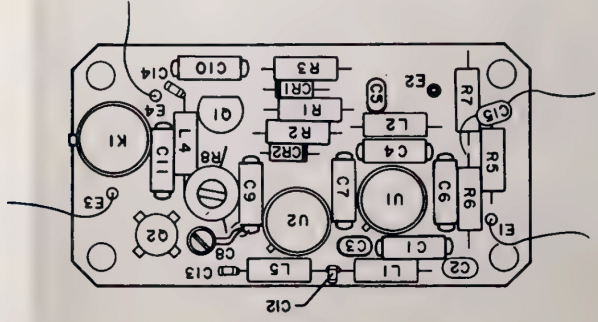

- NOTES:
1. ALL REFERENCE NUMBERS CARRY ASSIGNED DESIGNATOR SERIES. THIS SCHEMATIC CARRIES SERIES 9000 (E.G., R1 IS R9001).
  2. L3 IS FORMED FROM LEAD CB, CUT TO 2" LENGTH.
  3. ALL RESISTORS ARE 1/4 W, 5% TOLERANCE UNLESS OTHERWISE NOTED.
  4. ALL RESISTANCE IS EXPRESSED IN OHMS UNLESS OTHERWISE NOTED.
  5. ALL CAPACITANCE IS EXPRESSED IN MICROFARADS UNLESS OTHERWISE NOTED.
  6. ALL INDUCTANCE IS EXPRESSED IN MICROHENRYS UNLESS OTHERWISE NOTED.

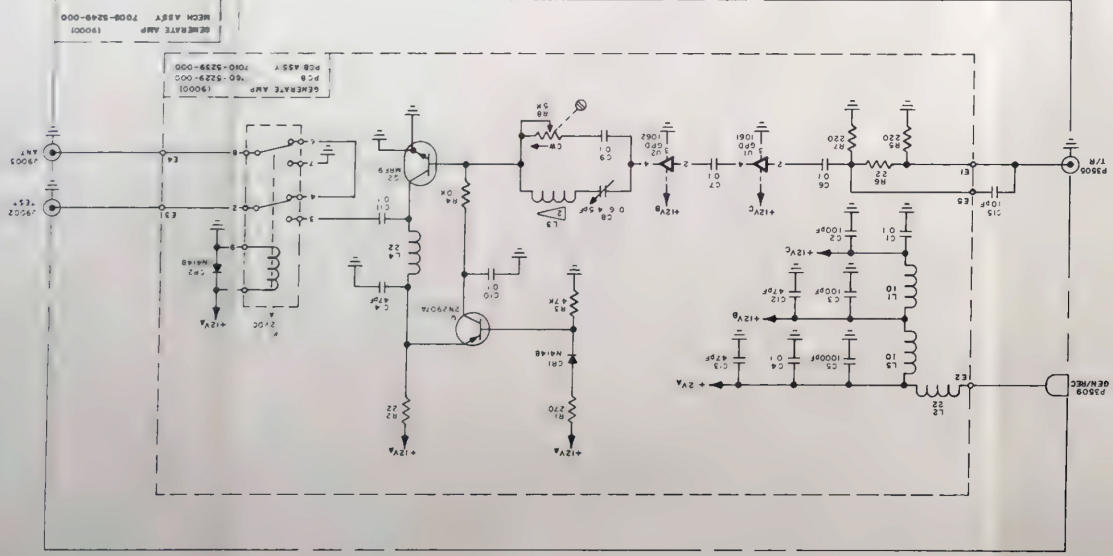

Figure 7-32 Generate Amplifier Assembly  
(Option 05)  
(0000-5219-000-8)