

## CONTENTS

GENERAL .....	2	PC BOARD VIEWS	
SYSTEM SET-UP .....	3	CONTROL UNIT(X53-3810-10) .....	59
INSTALLATION .....	4	TX UNIT(X56-3030-10) .....	65
REALIGNMENT .....	5	RX UNIT(X55-3040-10) .....	79
OPERATING FEATURES .....	7	SCHEMATIC DIAGRAM .....	85
CIRCUIT DESCRIPTION .....	10	BLOCK DIAGRAM .....	97
SEMICONDUCTOR DATA .....	29	LEVEL DIAGRAM .....	99
DESCRIPTION OF COMPONENTS .....	30	INTERCONNECTION DIAGRAM .....	101
PARTS LIST .....	33	KSP-1A/KES-4(EXTERNAL SPEAKER) .....	103
EXPLODED VIEW .....	45	KPG-46(PROGRAMMING INTERFACE CABLE) .....	104
PACKING .....	47	SPECIFICATIONS .....	BACK COVER
TERMINAL FUNCTION .....	48		
ADJUSTMENT .....	51		

## GENERAL

### INTRODUCTION

#### SCOPE OF THIS MANUAL

This manual is intended for use by experienced technicians familiar with similar types of commercial grade communications equipment. It contains all required service information for the equipment and is current as of the publication data. Changes which may occur after publication are covered by either Service Bulletins or Manual Revisions. These are issued as required.

#### ORDERING REPLACEMENT PARTS

When ordering replacement parts of equipment information, the full part identification number should be included. This applies to all parts : components, kits, or chassis. If the part number is not known, include the chassis or kit number of which it is a part, and a sufficient description of the required component for proper identification.

### PERSONNEL SAFETY

The following precautions are recommended for personnel safety :

- DO NOT transmit until you verify that all RF connectors are secure and any open connectors are properly terminated.
- SHUT OFF and DO NOT operate this equipment near electrical blasting caps or in an explosive atmosphere.
- This equipment should be serviced by a qualified technician only.

### SERVICE

This radio is designed for easy servicing. Refer to the schematic diagrams, printed circuit board views, and alignment procedures contained within.

### NOTE

WE CANNOT guarantee oscillator stability when using channel element manufactured by companies other than KENWOOD or its authorized agents.

### 1. Overview

The TKR-830 is a 400-MHz-band trunking repeater system radio unit.

### 2. Main Features

- (1) Dimensions Width : 19 inches, Height : 1.75 inches, Depth : 12 inches
- (2) Aluminum die-cast uni-body frame.
- (3) Number of Channels : 1CH (This channel is selected by using either Dip switch or a Control line from 32 preset channels.)
- (4) This radio has PC tuning as below:  
PC tuning RX : Squelch sensibility sensitivity, RA output level, RD output level  
TX : RF output power, Maximum deviation, TA deviation, TD deviation, TD balance,  
Manual tuning RX : Helical frequency bandwidth, MCF wave from, Quad coil  
TX : MIC sensitivity
- (5) Software is stored in flash memory and can be rewritten without opening the cover.
- (6) The following can be monitored on a PC :  
RX : VCO lock voltage, RF input level / TX : VCO lock voltage, RF output power.
- (7) Multi-mode (Wide : 25kHz / Narrow : 12.5kHz)
- (8) RF output power is adjustable from between 2 to 5 watts. It is 100% duty cycle.
- (9) This radio has an interface port for external equipment such as a Repeater controller.
- (10) This radio has grant of Type Approval for ETS and CE, FCC, and IC certification.
- (11) The Front panel has LED indicators for Power, TX, Busy, and REF. It also has two 7-segment displays, a Mic jack, a speaker, a Local AF volume control , and a TX test switch.
- (12) The Rear panel has a BNC connector for the RX input and the TX output. There is also an External Reference input, a DC supply connector, a 25 pin D-sub connector, a Fuse box, and a 15 pin Test I/O connector.
- (13) This radio requires an external 13.8V DC supply.
- (14) You can increase the RF output power of this radio to 25W by changing the final output device.
- (15) This radio has an External Reference input (10MHz) .



## SYSTEM SET-UP

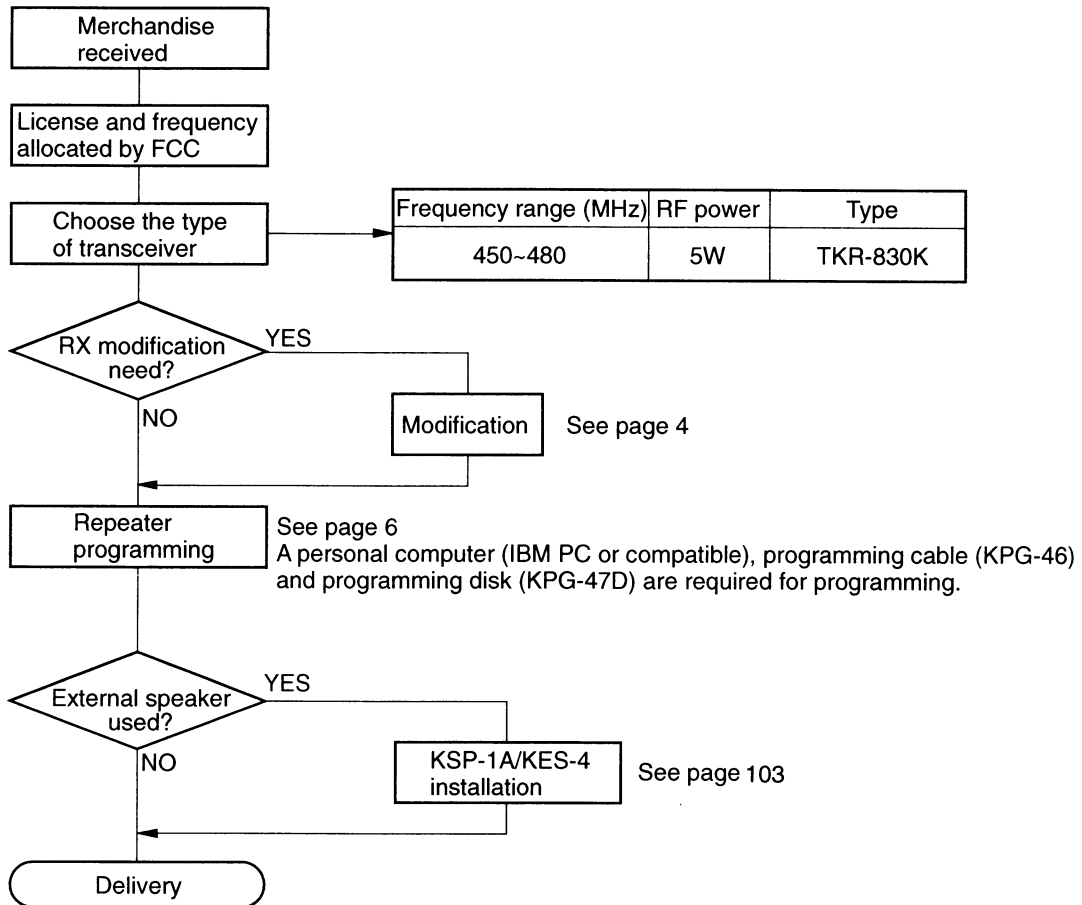

# TKR-830

## INSTALLATION

### RX MODIFICATION

When you modify the receiver system by using a narrow duplexer between the RX circuit and RX antenna, you don't need to use the L3 filter.

- ① Remove the RX cover panel.
- ② Remove the clip spring from IC4 and L16.
- ③ Remove the 12 screws from the RX unit and the 10 screws from the shield case.
- ④ Remove the jumper (R179) from the reverse side of the RX unit (X55-304).
- ⑤ Insert on SMB receptacle (E04-0409-05) at CN10. Solder the 5 leads in place.
- ⑥ Replace the screws on the RX unit and shield case, and the clip springs on IC4 and L16.
- ⑦ Move the RX. IN signal cable (from the back panel) from CN1 to CN10.
- ⑧ Attach a tacking generator signal to RX.IN, then use a spectrum analyzer to read the output at CN2 while adjusting L16 for the proper attenuation.
- ⑨ Next, adjust IF, squelch, and RSSI.
- ⑩ Replace the RX cover panel.

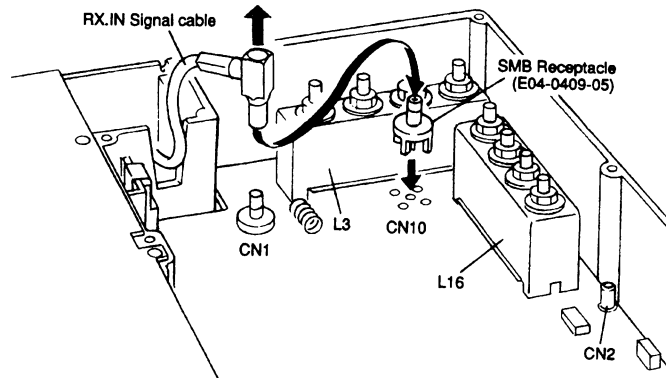
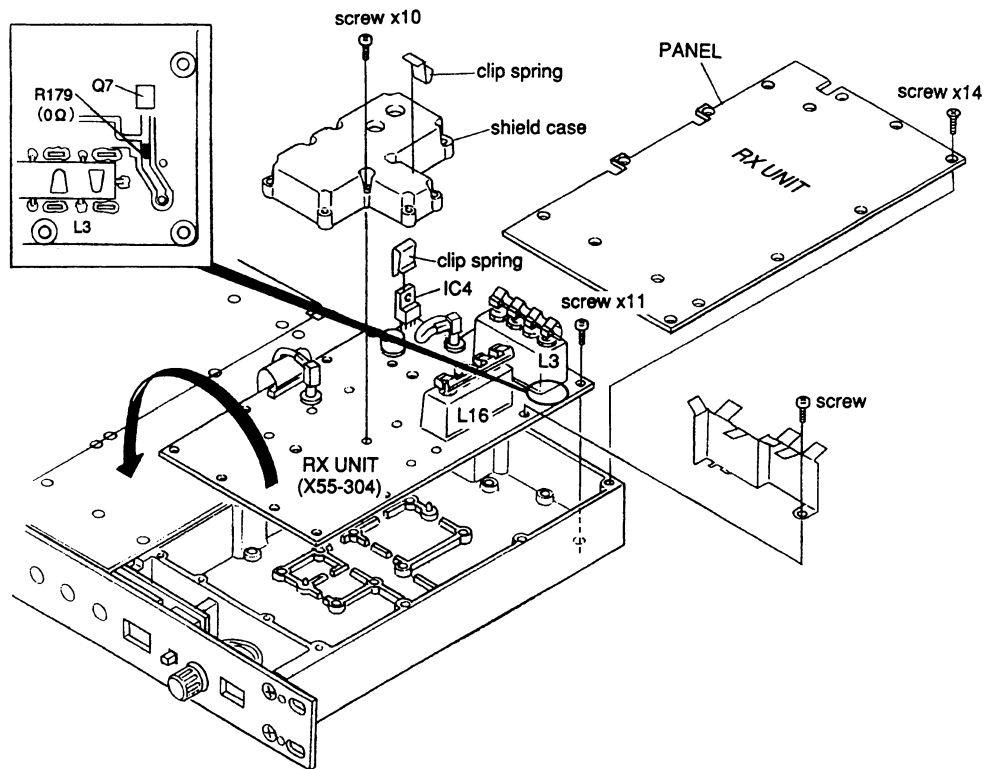

# REALIGNMENT

## 1. Modes

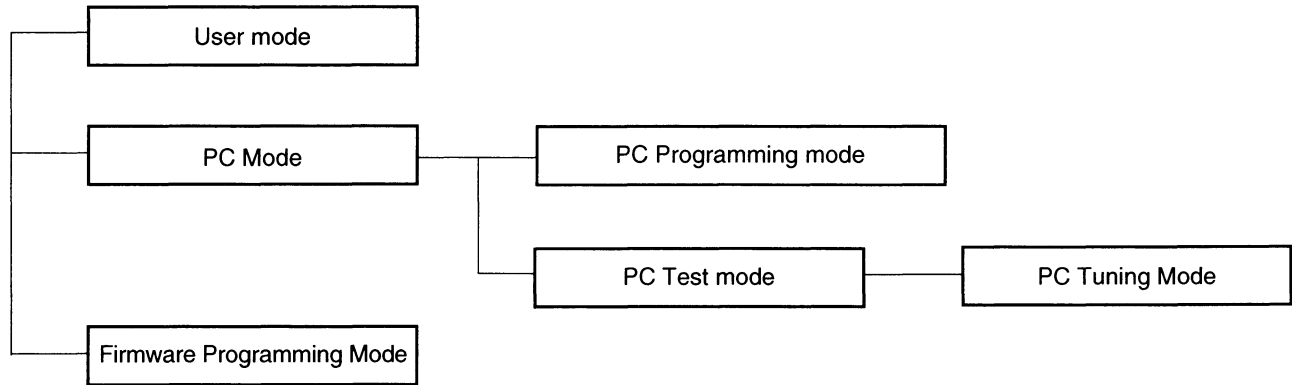

Mode	Function
User Mode	Use this mode for normal operation.
PC Mode	Use this mode to make various settings by means of the FPU through the RS-232C port.
PC Programming Mode	Use to read and write frequency data and other features to and from the Repeater.
PC Test Mode	Use to check the Repeater using the PC. This feature is included in the FPU.
Firmware Programming Mode	Use when changing the Firmware program of the flash memory.

## 2. How to Enter Each Mode

Mode	Operation
User Mode	Power ON.
PC Mode	Received commands from PC.
Firmware Programming Mode	Voltage is stored while you press the Test Switch. Press and hold the switch for 1 second so that all of the segments of the 7-segment display flash one time. Release the switch, and then press and hold it again within 1 second. "P.B" will appear after holding the switch for 1 second. Firmware Programming Mode is active.

# TKR-830

## REALIGNMENT

### 3. PC Mode

#### 3-1. Preface

The TKR-830 repeater is programmed by using a personal computer, programming interface

The program software can be used with an IBM PC or compatible. Figure 1 shows the setup of an IBM PC for programming.

#### 3-2. Connection procedure

1. Connect the TKR-830 to the personal computer with the interface cable.
2. When the power ON, user mode can be entered immediately. When PC sends command the repeater enter PC mode, and "PC" is displayed on the 7-segment LED. When data transmitting from repeater, the TX LED is blinking. When data receiving from repeater, the BUSY LED is blinking.

#### Notes:

- The data stored in the personal computer must match model type, when it is written into the flash memory.
- Change the TKR-830 to PC mode, then attach the interface cable.

#### 3-3. KPG-46 description (PC programming interface cable : Option)

The KPG-46 is required to interface the TKR-830 to the computer. It has a circuit in its D-subconnector (25-pin) case that converts the RS-232C logic level to the TTL level. The KPG-46 connects the universal connector of the TKR-830 to the computers RS-232C serial port.

#### 3-4. Programming software description

The KPG-47D programming disk is supplied in 3-1/2" disk format. The software on the disk allows a user to program TKR-830 repeaters via programming interface cable (KPG-46) .

#### 3-5. Programming with IBM PC

Data can be programmed into the flash memory in RS-232C format via the universal connector.

KPG-47D instruction manual parts No. : B62-1008-00

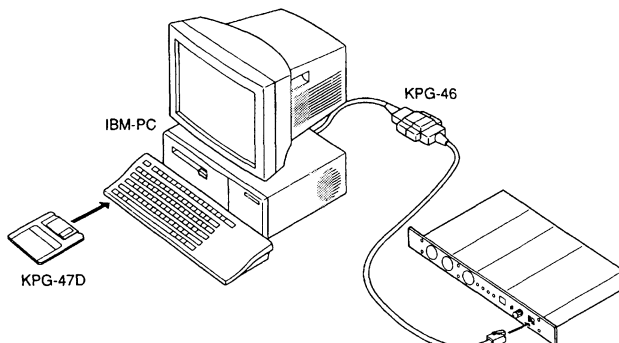

Fig.1

### 4. Firmware Programming Mode

#### 4-1. Preface

Flash memory is mounted on the TKR-830. This allows the TKR-830 to be upgraded when new features are released in the feature. (For details on how to obtain the firmware, contact Customer Service.)

#### 4-2. Connection procedure

Connect the TKR-830 to the personal computer (IBM PC or compatible) with the interface cable (KPG-46).(Connection is the same as in the PC Mode.)

#### Notes:

You can only program firmware from the 8-pin microphone connector on the front panel. Using the 25-pin logic interface on the rear panel will not work.

#### 4-3. Programming

3. Start up the programming software (KPG-47D), select "firmware program" in the "Program" item, and press the Return key on the personal computer. This starts up the firmware programmer.
4. The top screen is displayed. Press any key to advance to the next screen.
5. Set the communications speed (normally, 38400 bps) and communications port in the Setup item.
6. Set the firmware to be updated by File select (=F1)
7. Voltage is stored while you press the Test Switch. Press and hold the switch for 1 second so that all of the segments of the 7-segment display flash one time. Release the switch, and then press and hold it again within 1 second. "P.B" will appear after holding the switch for 1 second. Main Programing Mode is active.
8. Check the connection between the TKR-830 and the personal computer, and make sure that the TKR-830 is in the Program Mode.
9. Press F10 on the personal computer. A window opens on the display to indicate progress of writing.
10. If writing ends successfully, the TX LED on the TKR-830 lights.
11. If you want to continue programming other TKR-830s, repeat steps 5 to 8.

#### Notes:

- To start the Firmware Programmer from KPG-47D, the Fpro path must be set up by KPG-47D Setup.
- This mode cannot entered if the Firmware Program mode is set to Disable in the KPG-47D .

#### 4-4. Function

If you press the [TEST] switch (front panel), the right hand decimal point on the 7-segment display will light. The writing speed is 19200 bps (low-speed mode). If you press the [TEST] switch again, both decimal points will light. The writing speed is 38400bps (high-speed mode).

#### Notes:

Normally, write in the high-speed mode.

# OPERATING FEATURES

## CONTROLS AND FUNCTIONS

### ■ Front Panel

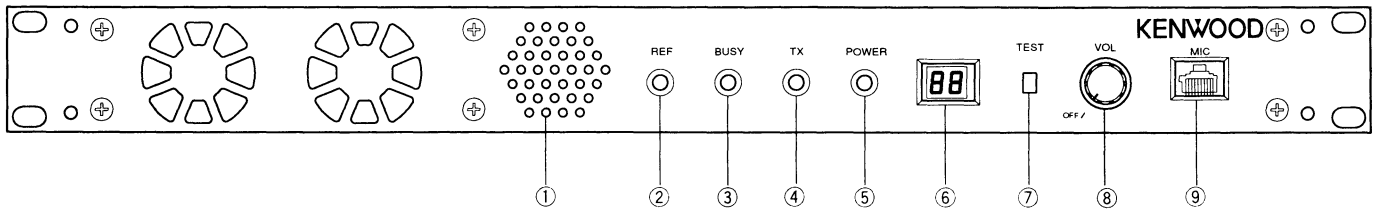

- ① **Speaker**
- ② **REF (reference) indicator**  
Lights red when using an external reference frequency.  
Lights green when using the internal reference frequency.
- ③ **BUSY indicator**  
Lights green when the channel is in use.
- ④ **TX (transmit) indicator**  
Lights red while transmitting.
- ⑤ **POWER indicator**  
Lights green when the power is turned ON.
- ⑥ **Display**  
Two, 7-segment digits display the channel number or status.
- ⑦ **TEST switch**  
Press to transmit an unmodulated signal with an external microphone connected.
- ⑧ **VOL (volume) control**  
Turn clockwise until a click sounds, to switch the power ON. Rotate to adjust the volume. Turn counterclockwise fully to switch the power OFF.
- ⑨ **MIC (microphone) jack**  
Connect a microphone to this 8-pin modular jack.

### ■ Rear Panel

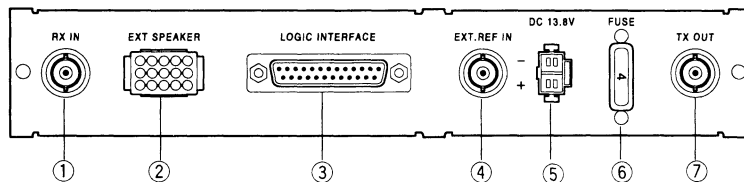

- ① **RX IN jack**  
Connect a RX antenna to this BNC receptacle.
- ② **EXT. SPEAKER jack**  
Test input/output jack. Connect an external speaker to this jack.
- ③ **LOGIC INTERFACE jack**  
Connect an external programming device to this DB-25 interface.
- ④ **EXT, REF IN jack**  
Connect an external reference frequency (10MHz) to this BNC receptacle.
- ⑤ **DC 13.8V jack**  
Connect a 13.8V DC power supply to this jack.
- ⑥ **FUSE**  
Insert a 4A blade fuse into this fuse holder.
- ⑦ **TX OUT jack**  
Connect a TX antenna to this BNC receptacle.

# TKR-830

## OPERATING FEATURES

### Logic interface (25pin) (D-SUB Connector) Back Panel

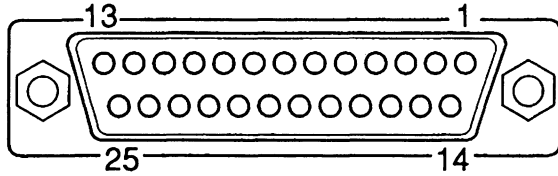

No.	Terminal name & Description
1	NC
2	RXD2 (PC serial data to radio)
3	TXD2 (PC serial data from radio)
4	NA (AUX1:IC9 Q5)
5	NA (AUX2:IC9 Q6)
6	NA (AUX3:IC9 Q7)
7	DG (Digital Ground)
8	TD (TX signal input)
9	TA (TX audio input)
10	RD (RX detector output)
11	RA (RX audio output)
12	RXG (RX Ground)
13	SPM (Speaker Mute)
14	NC
15	MON (Monitor SW)
16	PTT (Same test SW)
17	SC (SQ Control output)
18	NC (reserved for key)
19	TXG (TX Ground)
20	IN/EX SW (INT./EXT channel control select)
21	EC1 (EXT, Cannel bit select 1)
22	EC2 (EXT, Cannel bit select 2)
23	EC3 (EXT, Cannel bit select 3)
24	EC4 (EXT, Cannel bit select 4)
25	EC5 (EXT, Cannel bit select 5)

### EXT. Speaker (15pin) (TEST I/O Connector) Back Panel

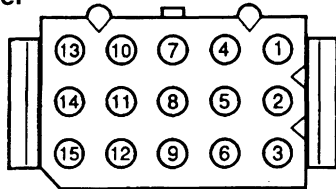

No.	Terminal name & Description
1	+B (AUX)
2	+B (AUX)
3	NC
4	GND
5	GND
6	SPG (Speaker Ground)
7	RD
8	RSSI
9	SPI (Internal Speaker Input)
10	TXCV
11	RXCV
12	SPO (Output for external Speaker 4W/4Ω)
13	VC (Voltage Check only)
14	FWD
15	EXT REF

### Internal channel setup switch (control unit) Method of setting up the channel using the DIP switches (S1 and S2)

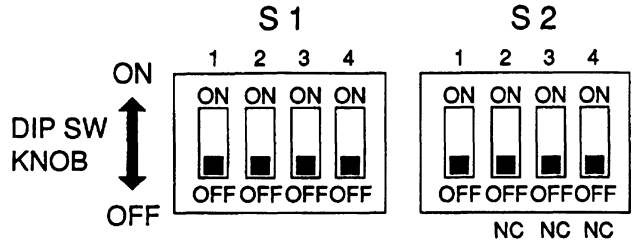

0 : ON  
1 : OFF

CH	S1				S2			
	1	2	3	4	1	2	3	4
1	1	1	1	1	1		NC	
2	0	1	1	1	1		NC	
3	1	0	1	1	1		NC	
4	0	0	1	1	1		NC	
5	1	1	0	1	1		NC	
6	0	1	0	1	1		NC	
7	1	0	0	1	1		NC	
8	0	0	0	1	1		NC	
9	1	1	1	0	1		NC	
10	0	1	1	0	1		NC	
11	1	0	1	0	1		NC	
12	0	0	1	0	1		NC	
13	1	1	0	0	1		NC	
14	0	1	0	0	1		NC	
15	1	0	0	0	1		NC	
16	0	0	0	0	1		NC	
17	1	1	1	1	0		NC	
18	0	1	1	1	0		NC	
19	1	0	1	1	0		NC	
20	0	0	1	1	0		NC	
21	1	1	0	1	0		NC	
22	0	1	0	1	0		NC	
23	1	0	0	1	0		NC	
24	0	0	0	1	0		NC	
25	1	1	1	0	0		NC	
26	0	1	1	0	0		NC	
27	1	0	1	0	0		NC	
28	0	0	1	0	0		NC	
29	1	1	0	0	0		NC	
30	0	1	0	0	0		NC	
31	1	0	0	0	0		NC	
32	0	0	0	0	0		NC	

## OPERATING FEATURES

### Display

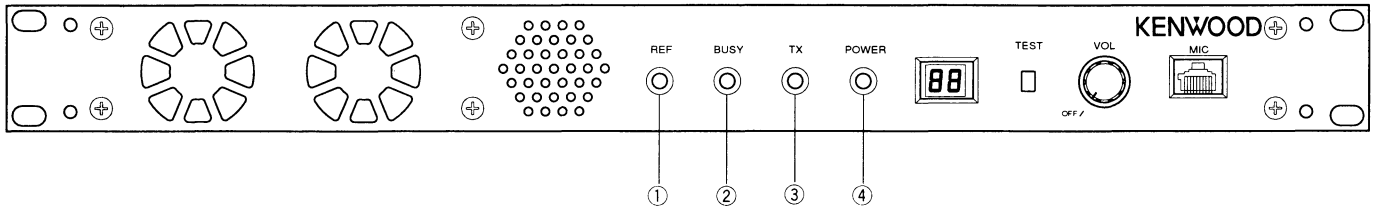

#### ① REF (Reference) LED

The LED is green when using the internal reference frequency and red when using an external reference.

#### ② BUSY LED

Lights green when receiving. Flashes when receiving data from the KPG-47D or when the receiving PLL is unlocked.

#### ③ TX LED

Lights red when transmitting. Flashes when transmitting data from the KPG-47D or when the transmit PLL is unlocked.

#### ④ POWER LED

Lights green when the power is ON.

### 7-segment LED Displays



- Channel display (1~32): while operating normally in User Mode

- "E2" display : when the channel data is not written.

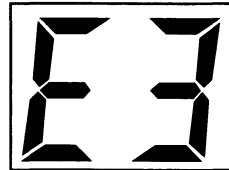

- "PC" display : while in PC Mode

- "E3" display : when PLL is unlocked  
When receive PLL is unlocked : BUSY LED flashes.  
When transmit PLL is unlocked : TX LED flashes.  
When the standard 19.2MHz is unlocked : the 7-segment display decimal point flashes.



- "PG" display : while in Firmware Programming Mode  
2 decimal points are displayed : 38.400 bps  
1 decimal point is displayed : 19.200 bps



- "E4" display : when you try to transmit on a channel that dose not have a frequency set up.

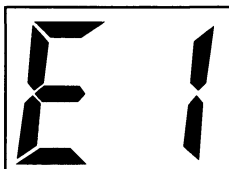

- "E1" display : when FPU data is not written.

## CIRCUIT DESCRIPTION

### Outline

The TKR-830 is a UHF-band relay radio unit for business radio applications. It is designed as a high-performance model with enhanced basic transmit/receive functions. The TKR-830 also has the PC tune and PC monitor functions and its circuits are configured to support future upgrading flexibly.

The TKR-830 has three PLL circuits in the transmitter unit and two PLL circuits in the receiver unit. All the PLL circuits are controlled with the same basic frequency, so the transmit and receive frequencies are very stable compared with the previous models. It uses a new circuit design to modulate the transmit reference PLL and the transmit main PLL at the same time during transmission. Therefore, it features flat modulation characteristics from a low-frequency range regardless of whether the external reference frequency or the internal TCXO is used.

### (1) Internal/external reference circuit

The internal/external reference circuit switches between the internal +/-1.0ppm/20MHz TCXO X101 and the 10MHz external reference automatically. If there is no external reference input, the internal TCXO is used as the basic frequency for PLL circuits. When the external reference (10MHz/-10dBm or higher) is input to CN101, the external reference is used as the reference frequency for all PLL circuits. The circuits operate as follows.

When the external reference signal (10MHz) is input, its impedance is converted by an emitter follower (Q102). Then, harmonic components are generated by a double amplifier. Only the 20MHz component is taken by the MCF XF210 and sent to D101 and high-frequency amplifier Q205. The 20MHz signal amplified by Q205 is converted to a direct current voltage by the double-voltage detection circuit consisting of C265 and D205. The direct current voltage is compared with the reference voltage by comparator IC204. If the detected direct current voltage is higher than the reference voltage, the comparator output changes from "L" to "H".

The comparator output switches Q110, Q111, Q112, Q113,

### Transmitter circuit

The transmitter unit (X56-303- A/3) consists of (1) internal/external reference circuit, (2) transmit reference PLL circuit, (3) receive reference PLL circuit, (4) transmit main PLL circuit, (5) driver circuit, (6) modulation level adjustment circuit, and (7) other circuits.

and Q114 switching transistors. Q110 turns "OFF" and Q114 turns "ON". Switching diode D101 conducts (since Q110 is "OFF", D103 does not conduct). The 20MHz reference signal generated from the external reference signal is input to IC201 and IC202 and the external reference signal is used as the reference frequency.

When the comparator output turns Q206 "ON", the comparator reference voltage decreases by a certain level, and hysteresis characteristics are obtained. Even if the external reference level changes slightly, the comparator output does not change. If there is no external reference input, the double voltage detection circuit C265 and D205 does not output any signal, the comparator output is "L". Therefore, Q114 turns "OFF" and Q110 turns "ON". Power is supplied to the internal TCXO and D103, the internal TCXO 20MHz reference signal is input to IC201 and IC202, and the internal TCXO is used as the reference frequency. The TCXO frequency stability may be affected by the output load impedance. The TKR-830 has a MOS FET buffer amplifier Q15 to stabilize the TCXO output load impedance and its frequency.

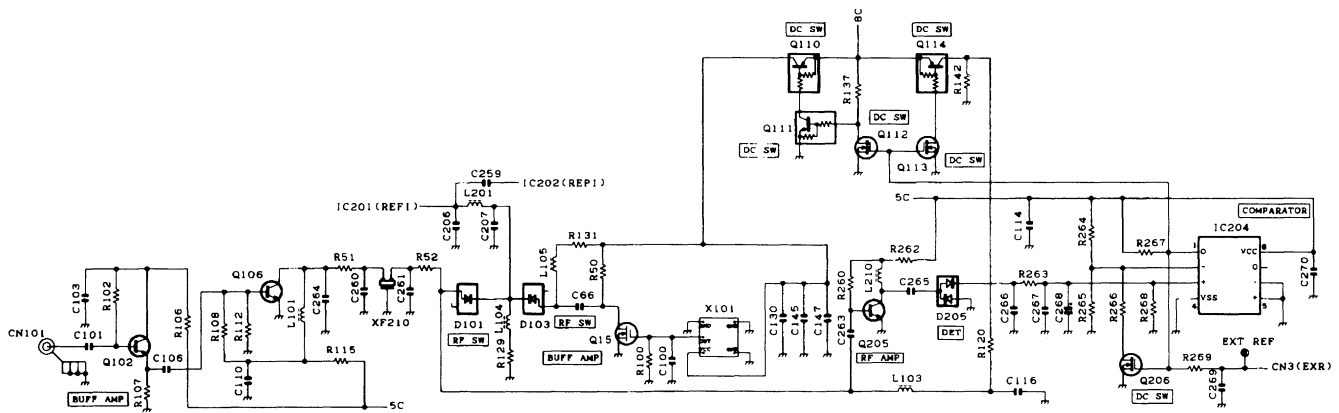

Fig.1 Internal/external reference circuit



## CIRCUIT DESCRIPTION

### (2) Transmit reference PLL circuit

The transmit reference PLL circuit generates the reference frequency signal (19.2MHz) for the transmit main PLL and consists of IC201, X201, Q201, and Q202.

The VCO has a no-adjustment type crystal oscillator circuit (based on a Colpitts circuit) consisting of Q201 and X201, varicap D203 for modulation, and varicap D201, D202 for changing the oscillator frequency by direct current voltage.

The signal generated by the VCO is fed to buffer amplifier Q202. The signal then goes to a "pi" type LPF to remove unwanted harmonic components. The resulting signal goes to the

fractional N type single-chip PLL IC (IC201), and the phase of the divided frequency (200kHz) is compared with that of the reference frequency. The phase difference signal enters the internal charge pump, is converted to an analog signal (0 to 5 V) and output from the PHA pin. Then, the signal is converted to a direct current voltage by a laglead type loop filter. The capacity of D201 and D204 is varied by the direct current voltage to keep the VCO oscillator frequency 19.2MHz.

The stabilized 19.2MHz oscillator signal is taken from the LPF output, output to IC101 Xin pin, and used as the reference frequency signal for the transmit main PLL.

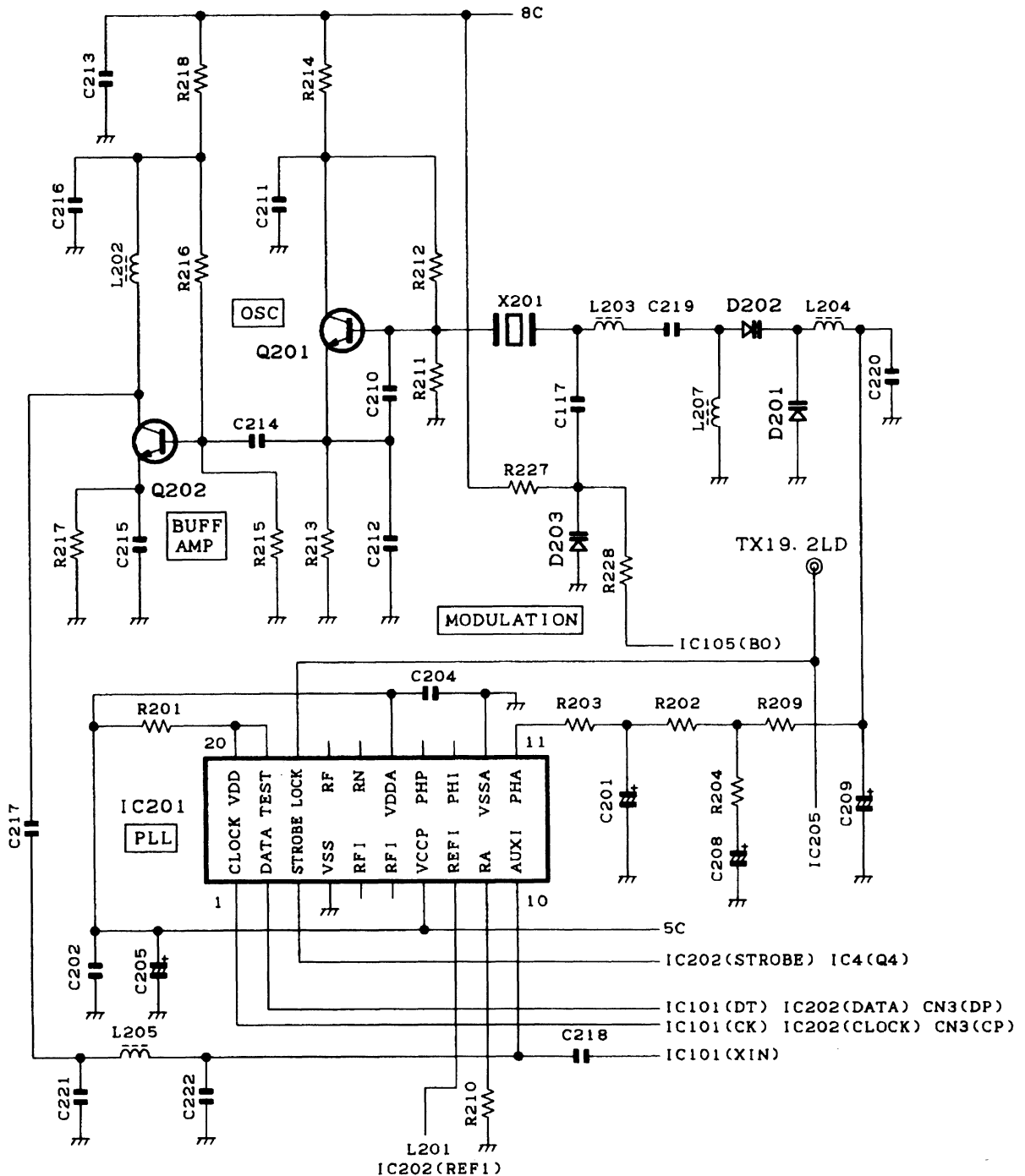

Fig.2 Transmit reference PLL circuit

## CIRCUIT DESCRIPTION

### (3) Receive reference PLL circuit

The receive reference PLL circuit produces the reference frequency signal (19.2MHz) for the receive PLL (first and second local oscillator), and consists of IC202, X202, Q204, and Q241.

The VCO contains a no-adjustment type crystal oscillator circuit (based on a Colpitts circuit) consisting of Q240 and X202 and varicap D240 for changing the oscillator frequency by direct current voltage.

The signal generated by the VCO is fed to the buffer amplifier Q241. The signal then goes to a "pi" type LPF to remove unwanted harmonic components. The resulting signal goes to the fractional N type single-chip PLL IC (IC202), and the phase of the divided frequency (200kHz) is compared with that of the reference frequency. The phase difference signal enters the internal charge pump, is converted to an analog signal (0 to 5 V) and output from the PHA pin. Then, the signal is

converted to a direct current voltage by a laglead type loop filter. The capacity of D240 is varied by the direct current voltage to keep the VCO oscillator frequency 19.2MHz.

The stabilized 19.2MHz oscillator signal is taken from the LPF output, output to IC101 Xin pin, and used as the reference frequency signal for the receive PLL (first and second local oscillator). The impedance is converted by emitter follower amplifier Q115. The resulting signal passes through the "pi" type LPF and goes to the receive PLL reference output pin CN102.

The unlock signals for the transmit reference PLL circuit and receive reference PLL circuit are output from pin 18 (LOCK) of IC201 and IC202. The two unlock signals are ANDed, and the reference PLL unlock signal (LDS) is sent from CN3 to the control unit.

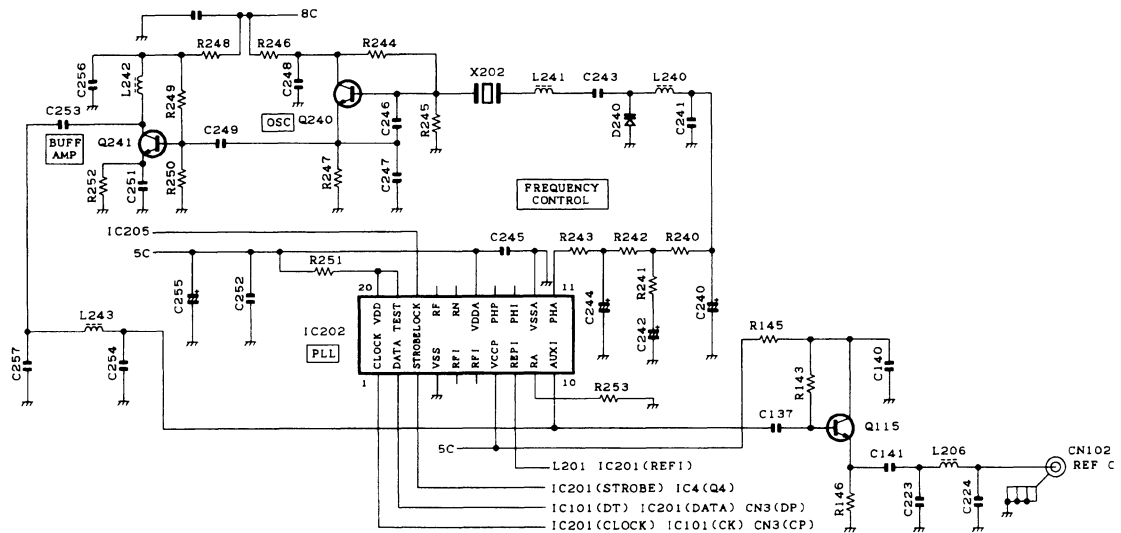

Fig.3 Receive reference PLL circuit

### (4) Transmit main PLL circuit

The transmit main PLL circuit generates the transmit frequency signal. This circuit consists of a clap type oscillator VCO consisting of Q1 and Q2 and single-chip PLL IC (IC101). When transmitting 450.0000 MHz to 464.995 MHz, the Q2 VCO oscillates and Q1 stops. The switching operation is performed by controlling switching transistors Q3, Q4, and Q5 using the output Q1 from shift register IC4.

The signal generated by Q1 or Q2 is fed to buffer amplifier Q6. Q6 provides isolation, and the signal goes to the high frequency amplifiers Q9 and Q107. Q107 amplifies the signal to the level required for the internal prescaler in IC101. Unwanted harmonic waves are removed by the "pi" type two-step LPF, and the resulting signal is input to IC101 Fin pin. IC101 divides

the VCO oscillator signal input to Fin and the transmit PLL reference signal (19.2MHz) input to Xin by the divide ratio, and the phase is compared with the 12.5kHz comparison frequency. The phase difference signal detected by phase comparison enters the internal charge pump, is converted to an analog signal (0 to 5 V) and output from the Do pin.

The analog signal output from the Do pin is converted to a direct current signal by the laglead type loop filter. The direct current signal is applied to varicap D1, D3, D2, D4 to lock the VCO oscillator frequency with the desired oscillator frequency. The direct current signal passes through the IC109 operational amplifier and buffer amplifier, and is output from CN3 as the voltage signal (CVT) for monitoring the transmit main PLL lock voltage.

## CIRCUIT DESCRIPTION

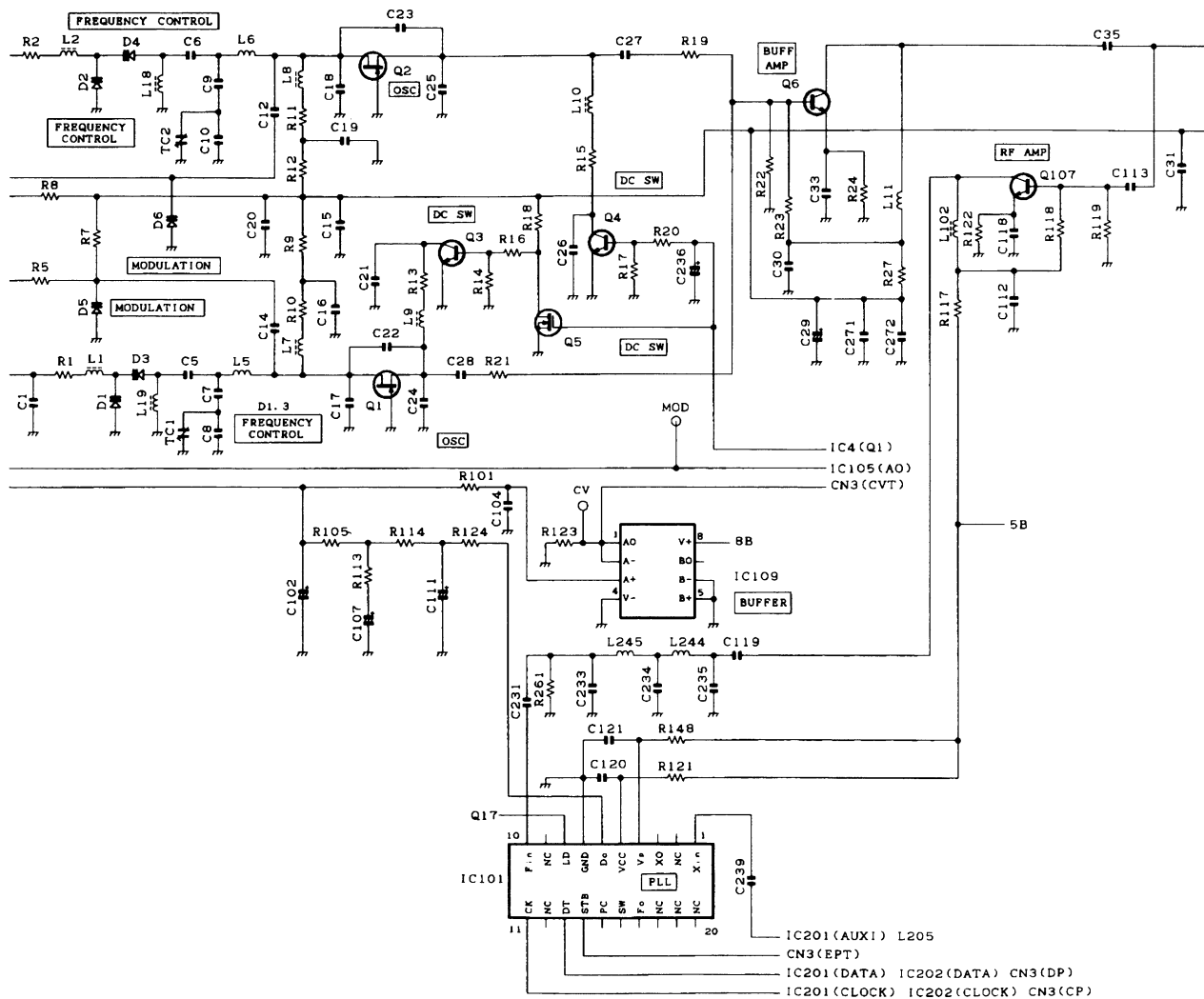

Fig.4 Transmit main PLL circuit

**(5) Driver circuit**

The driver circuit amplifies the transmit frequency signal generated by the transmit main PLL circuit to the level required for input to the final unit (X56-303 B/3). The driver circuit consists of high frequency amplifier Q9, high frequency switch D7, D10, high frequency amplifier Q13, high frequency amplifier Q14, direct current amplifier Q17, and switching elements Q18, Q203, Q8, Q16, Q10, Q12, and Q11.

When the transmit main PLL is locked, the IC101 LD pin goes "H", and the collector of Q17 goes "L". The collector of Q18 goes "H", the collector of Q203 goes "L", and the collector of Q8 goes "H". The logic is the opposite to the logic when the transmit main PLL is unlocked.

The transmit main PLL lock signal is output to CN3 as a signal "LDT" from the collector of Q18. This signal is used for the CPU in the control unit to monitor the lock state of the transmit main PLL. (See the control unit circuit description.)

When the collector of Q8 goes "L", Q16 turns "ON" and Q11 turns "OFF" regardless of whether the base voltage of Q10 is "H" or "L". Therefore, the power 8T for the drive is not provided. When the circuit is unlocked, it is protected to inhibit transmission.

The transmitter operation is controlled according to the data sent from the CPU in the control unit to shift register IC4. When IC4 pin 5 Q2 is "L" and the collector of Q8 is "H" (the transmit main PLL is locked), Q16 and D10 turn "OFF" and Q12 and Q11 turn "ON", 8T is supplied to the drive stage, D7 turns "ON", and the transmit signal is sent to Q13.

The transmit signal level input to Q13 is about 0 dBm. Q13 amplifies it by about 10 dB, and Q14 also amplifies it by about 10 dB. 20 dBm (about 100 mW) is output from drive output connector CN1.

## CIRCUIT DESCRIPTION

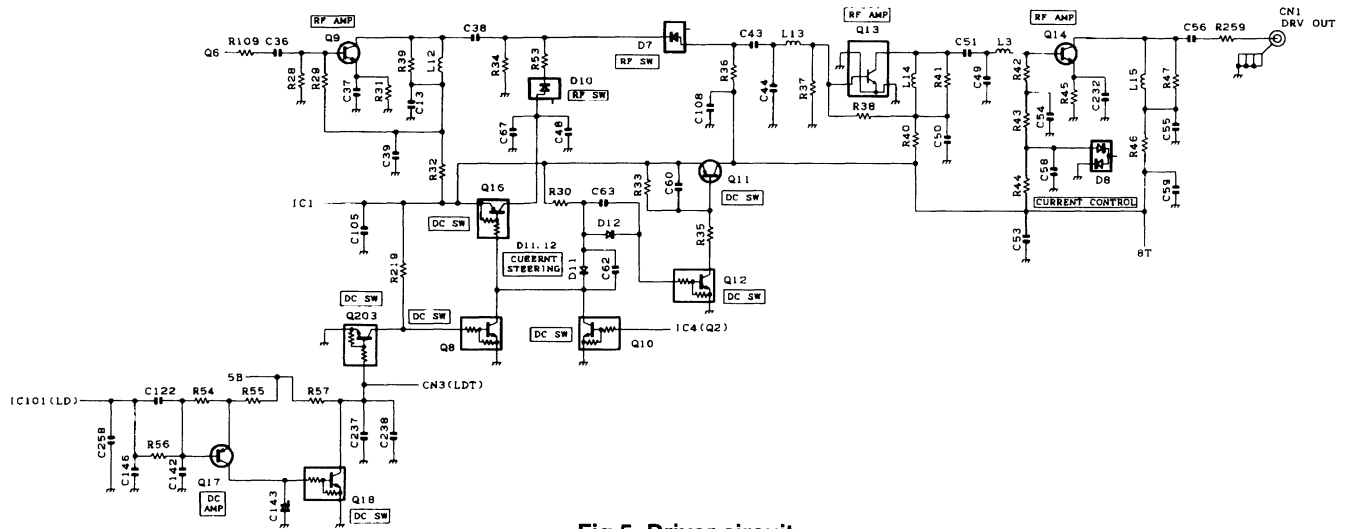

Fig.5 Driver circuit

### (6) Modulation level adjustment circuit

The modulation level adjustment circuit adjusts the modulation signal level and provides specified modulation. It consists of IC105, IC3, IC100, and IC203.

IC3 is an electronic volume IC. The signalling frequency change adjustment, signalling modulation balance adjustment (transmit reference PLL and transmit main PLL are modulated at the same time to provide flat modulation characteristics), maximum sound frequency change, and the reference voltage setting for transmission power adjustment can be performed

for each transmit frequency and for each channel using the FPU (KPG-47D) and a personal computer.

IC105 is a modulation signal summing amplifier (A/2) (sums the sound signal and the signalling signal whose balance is adjusted and modulates the transmit main PLL) and a signalling signal amplitude fine-adjustment amplifier (B/2).

IC203 is a DC amplifier that fine-adjusts the transmission power reference voltage generated by IC3. The "PC" signal is output to the final unit from connector CN.

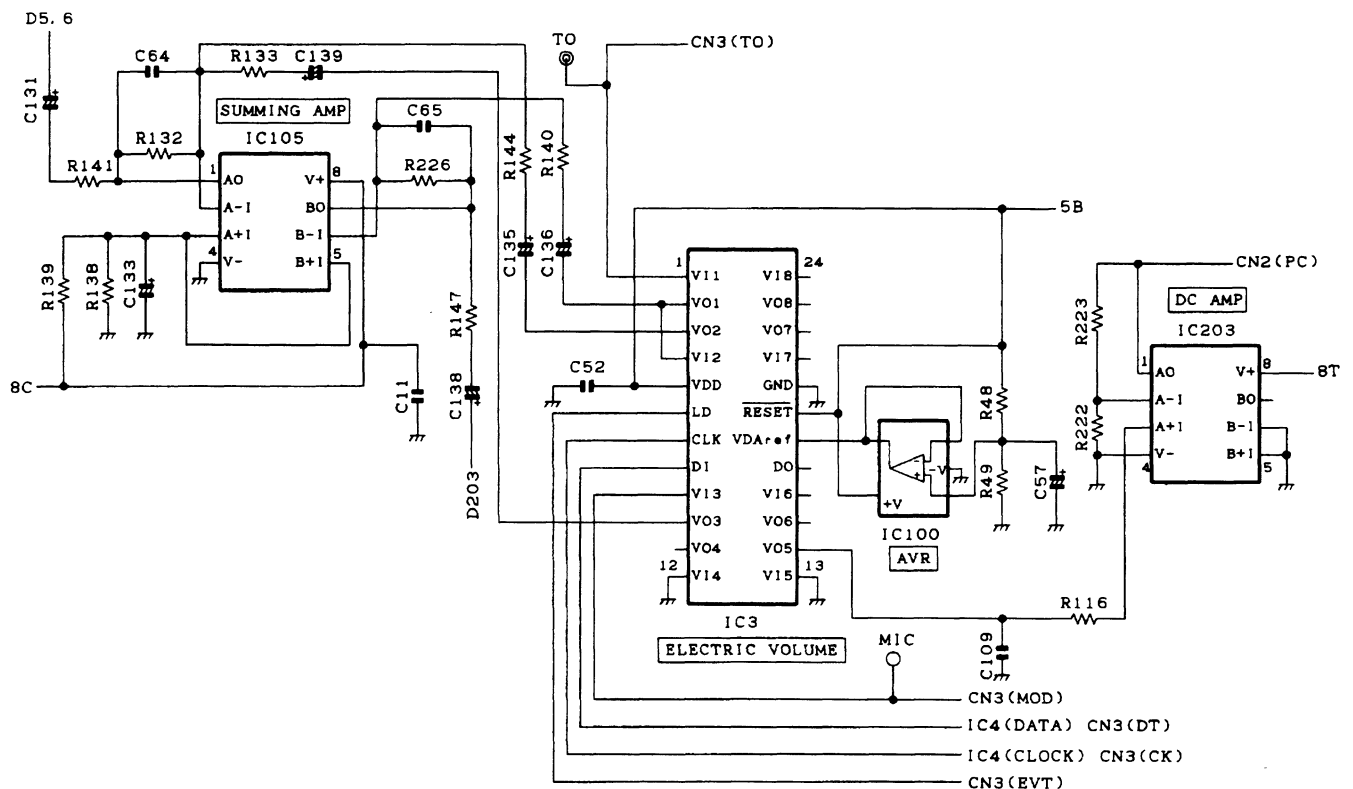

Fig.6 Modulation level adjustment circuit

## CIRCUIT DESCRIPTION

### (7) Other circuits

IC106 is an EEPROM. The transmit adjustment data adjusted for each unit is written into the EEPROM. If the unit is installed in another set, it is not necessary to adjust it again.

IC1, IC2, IC103, IC108, and IC110 are three-pin constant-voltage power supply ICs. Each circuit contains its own power IC to maintain isolation between circuits.

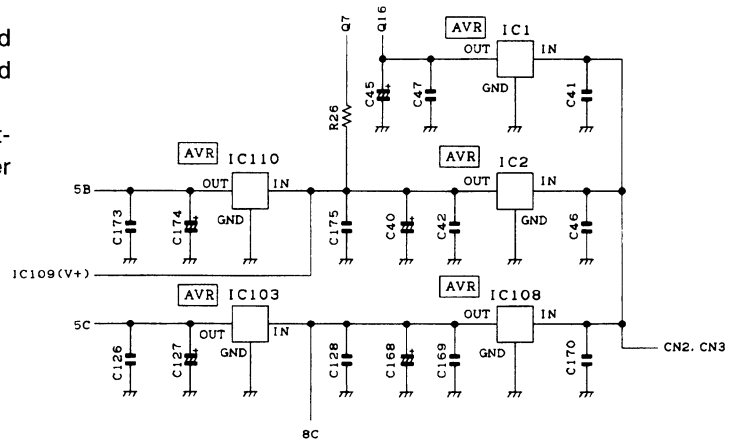

Fig.7 Other circuits

### Filant Unit

The final unit (X56-303 B/3) amplifies the transmission power to a specified level. This unit consists of (1) transmission power amplifier, (2) harmonic wave elimination circuit, (3) progressive wave power/reflected wave power detection circuit, (4) APC circuit, (5) abnormal temp. Detection circuit, and (6) common mode unwanted radiation prevention circuit.

#### (1) Transmission power amplifier

The transmission power amplifier IC301 uses a power module S-AU50M for portable transceivers to improve its efficiency. Driver output CN1 of the transmit unit is fed to CN301 of the final unit through a coaxial cable, and enters pin 1 of transmission power amplifier IC301 through a 5dB attenuator. The transmission power amplifier IC301 amplifies the power to the level corresponding to the voltage at the power control pin (pin 2) and outputs it from the output pin (pin 4).

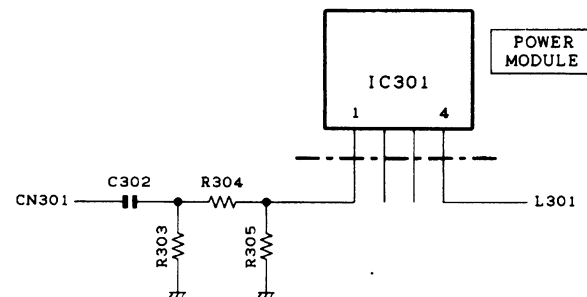

Fig.8 Transmission power amplifier

#### (2) Harmonic wave elimination circuit

The harmonic wave elimination circuit is a three-stage "pi" type Chebyshev type LPF consisting of L301, L302, L303, C307, C312, C315, and C316. This circuit removes harmonic wave components from the transmission power amplified by the transmission power amplifier and sends the resulting signal to the progressive wave power/reflective wave power detection circuit.

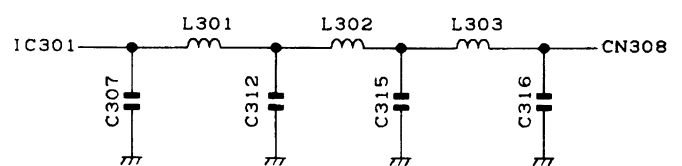
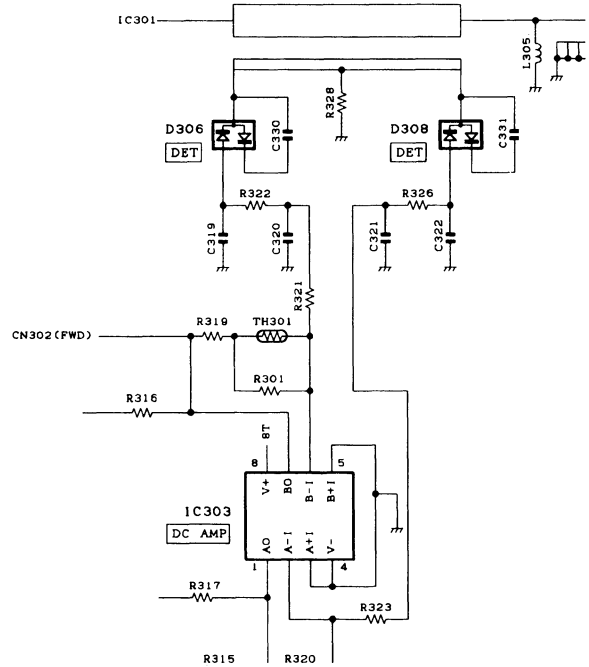

Fig.9 Harmonic wave elimination circuit

## CIRCUIT DESCRIPTION

### (3) Progressive wave power/reflected wave power detection circuit

The progressive wave power/reflective wave power detection circuit consists of a  $1/4 \lambda$  CM coupling type detection circuit formed by a strip line and a direct current amplifier IC303. The CM coupling detection circuit detects a negative voltage corresponding to a square root of the power values of the progressive wave and reflective wave. (D306 detects progressive wave and D308 detects reflective wave.) The progressive wave voltage FWD is sent to the APC circuit and control unit in the next stage, and reflective wave voltage REV is sent to the control unit through CN302. Thermistor TH301 corrects the thermal characteristics of the detection diode and keeps the APC function stable within the operation temperature range. Transmission power passes through the strip line and is output from CN308.

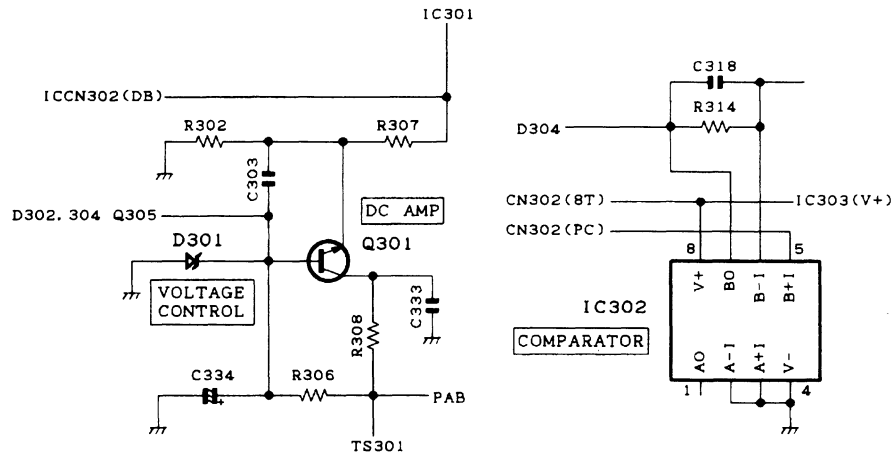

**Fig.10 Progressive wave power/reflected wave power detection circuit**

### (4) APC circuit

The APC circuit consists of differential amplifier IC302 and direct current amplifier Q301. IC302 places the transmission power setting voltage PC and progressive wave detection voltage FWD from the transmit unit to + input and - input, and outputs voltage Vd amplified according to the difference between the voltages. (If  $PC > FWD$ , Vd increases, and if  $PC < FWD$ , Vd decreases.) The voltage Vd is applied to direct current amplifier Q301 in the next stage. The voltage is converted to output voltage Vg to control the power control pin (pin 2) of the transmission power amplifier IC301. At the power control pin, the transmission power increases when the voltage Vg increases, and decreases when Vg decreases. A loop is formed between transmission power, FWD, Vd, and Vg, and

the transmission power converges into the point where the transmission power setting voltage PC and progressive wave detection voltage FWD are equal. The transmission power can be controlled according to the transmission power setting voltage PC. The +B voltage is applied to the power pin (pin 3) of the transmission power amplifier IC301 even when the final unit is not in transmit mode. When the voltage Vg is applied to the power control pin, the current flows to the power pin of IC301. In this case, there may be some problems, such as no isolation of the input and output of IC301. To prevent this problem, the switching transistors Q304 and Q305 are switched by transmission power 8T input through CN302 and the Vg voltage is grounded when transmission is not made.



**Fig.11 APC circuit**

## CIRCUIT DESCRIPTION

### (5) Abnormal temp. detection circuit

The abnormal temp. Detection circuit consists of thermal switch TS301 and digital transistor Q302. This circuit reduces the transmission power amplifier function and prevents temp. Rise to protect the circuits when the final unit temp. Rises excessively and the circuits cannot be operated safely. This circuit rarely activate during normal use. When the thermal switch detects the operating temp., the internal switch of the thermal switch conducts. When the voltage is applied to the base of Q302, digital transistor Q302 turns "ON". The collector of digital transistor Q302 grounds the differential amplifier output voltage Vd of the APC circuit to reduce transmission power.

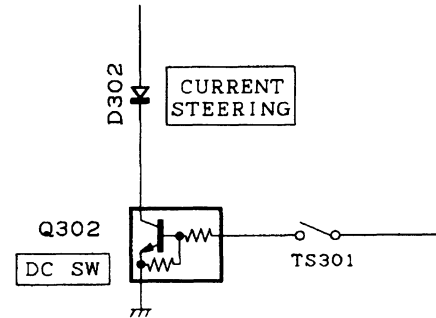

Fig.12 Abnormal temp. detection circuit

### (6) Common mode unwanted radiation prevention circuit

Common mode unwanted radiation prevention circuit. The TKR-830 has a filter L304 in the power line in the final unit to reduce unwanted radiation in common mode from the power cable.

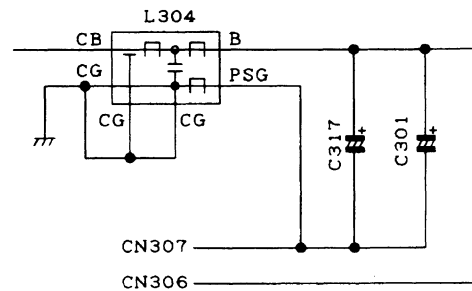

Fig.13 Common mode unwanted radiation prevention circuit

## Receiver Circuit

The receiver unit (X55-304) consists of (1) front-end circuit, (2) narrow IF circuit, (3) wide IF circuit, (4) first oscillator PLL circuit, (5) second oscillator PLL circuit, (6) base band circuit, and (7) other circuits.

### (1) Front-end circuit

The front-end circuit consists of helical BPF L3, high frequency amplifier Q7, helical BPF L16, mixer DBM A1, and IF switching circuit D10. The receive signal coming through CN1 goes to helical BPF L3. Unwanted signal components are damped and only the necessary band (about 5MHz) signal is sent to the high frequency amplifier Q7. The operating point of Q7 is set to maximize the gain and minimize distortion. The helical BPF L16 removes the unwanted out-of-band high frequency

components produced by high frequency amplifier Q7 and unwanted components leaked from the previous circuits, and sends only the necessary signal to mixer DBM A1. The mixer DBM A1 mixes the first local oscillator signal generated by the first local oscillator PLL with the receive signal coming from the helical BPF L16 to produce a first IF signal (73.05MHz). The first IF signal is switched to the narrow or wide IF circuit by the switching diode D10.

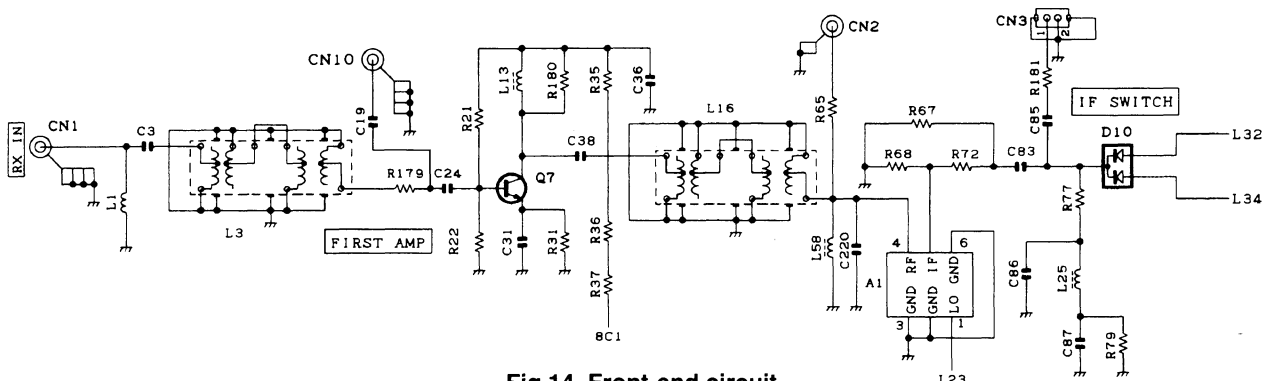

Fig.14 Front-end circuit

## CIRCUIT DESCRIPTION

### (2) Narrow IF circuit

The narrow IF circuit consists of two-pole MCF XF2, four-pole MCF XF4, IF amplifier Q25, IF amplifier Q32, FM detection IC IC7, ceramic filter CF1, and CF3. The unwanted components of the first IF signal connected to the narrow IF circuit by the switching diode D10 are removed by the overtone type two-pole MCF XF2. The resulting signal is amplified by IF amplifier Q25. Unwanted signal components are further eliminated by the overtone type four-pole MCF XF4 to maintain three-signal characteristics. The first IF signal output from XF4 is amplified by IF amplifier Q32 and input to pin 24 of FM detection IC IC7. The FM detection IC mixes the second PLL local oscillator signal with the first IF signal to generate a second IF signal (450kHz). Unwanted components of the second IF signal are removed by ceramic filter CF1. The resulting signal is amplified by the IF amplifier in IC7. Unwanted components of the amplified signal are further removed by ceramic filter CF3 to improve the two-signal characteristics of the IF stage. The signal then enters the quadrature detection circuit. The signal

with a phase shifted 90 degrees by phase shift coil L53 is compared with the original signal waveform to perform FM detection and generate the base band signal. The base band signal is output from pin 15 of IC7 and enters the low frequency amplifier IC11 (A/2 and B/2). The signal amplified by IC11 (A/2) goes to the Y0 input of multiplexer IC9 and the V2 input of electronic volume IC9. The level of the signal that enters V2 of the electronic volume IC is adjusted, the signal passes through the hysteresis circuit AF switch Q34. The signal goes to IC7 noise filter input (pin 17), and high frequency components are removed by a HPF. The signal is noise-detected and compared, and the noise squelch signal (N-DET) is fed to DC switch Q36. The voltage signal (RSSI) corresponding to the IF signal strength from the two second IF amplifiers in IC7 are compared with the reference voltage set by electronic volume V4 by the internal RSSI comparator, and the RSSI squelch signal (C-DET) is output from pin 20 of IC7. C-DET enters DC switch Q37 and is ANDed with N-DET by DC switch Q38. A squelch signal (SC) is output from connector CN6.

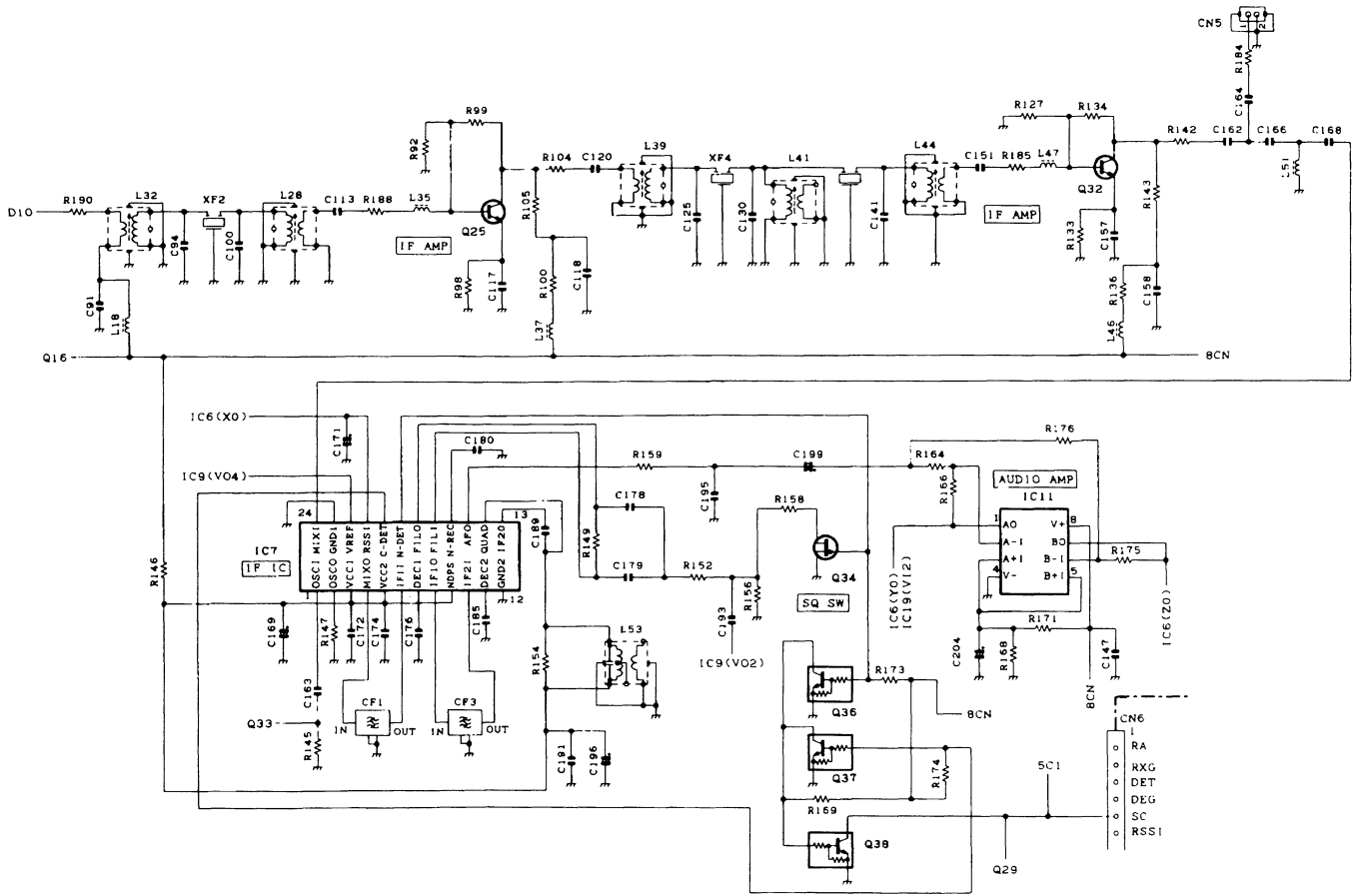

Fig.15 Narrow IF circuit



## CIRCUIT DESCRIPTION

### (3) Wide IF circuit

The wide IF circuit consists of two-pole MCF XF1, four-pole MCF XF3, IF amplifier Q24, IF amplifier Q31, FM detection IC IC8, ceramic filter CF2 and CF4. The unwanted components of the first IF signal connected to the wide IF circuit by the switching diode D10 are removed by the overtone type two-pole MCF XF1. The resulting signal is amplified by IF amplifier Q24. Unwanted signal components are further eliminated by the overtone type four-pole MCF XF3 to maintain three-signal characteristics. The first IF signal output from XF3 is amplified by IF amplifier Q31 and input to pin 24 of FM detection IC IC8. The FM detection IC mixes the second PLL local oscillator signal with the first IF signal to generate a second IF signal (450kHz). Unwanted components of the second IF signal are removed by ceramic filter CF2. The resulting signal is amplified by the IF amplifier in IC8. Unwanted components of the amplified signal are further removed by ceramic filter CF4 to improve the two-signal characteristics of the IF stage. The signal then enters the quadrature detection circuit. The signal with a phase shifted 90 degrees by phase shift coil L52 is compared with the original signal waveform to perform FM

detection is performed and generate the base band signal. The base band signal is output from pin 15 of IC8 and enters the low frequency amplifier IC12 (A/2 and B/2). The signal amplified by IC12 (A/2) goes to the Y1 input of multiplexer IC and the V1 input of electronic volume IC9. The level of the signal that enters V1 of the electronic volume IC is adjusted, and the signal passes through the AF switch Q35. The signal goes to IC8 noise filter input (pin 17), and high frequency components are removed by a HPF consisting of external CRs. The signal is noise-detected and compared, and the noise squelch signal (N-DET) is fed to DC switch Q36. The voltage signal (RSSI) corresponding to the IF signal strength from the two second IF amplifiers in IC8 are compared with the reference voltage set by electronic volume V3 by the internal RSSI comparator, and the RSSI squelch signal (C-DET) is output from pin 20 of IC8. C-DET enters DC switch Q37 and is ANDed with N-DET by DC switch Q38. A squelch signal (SC) is output from connector CN6. The C-DET signal and N-DET signal are the same for both the wide and narrow IF circuits. (The wide and narrow IF circuits do not operate at the same time.)

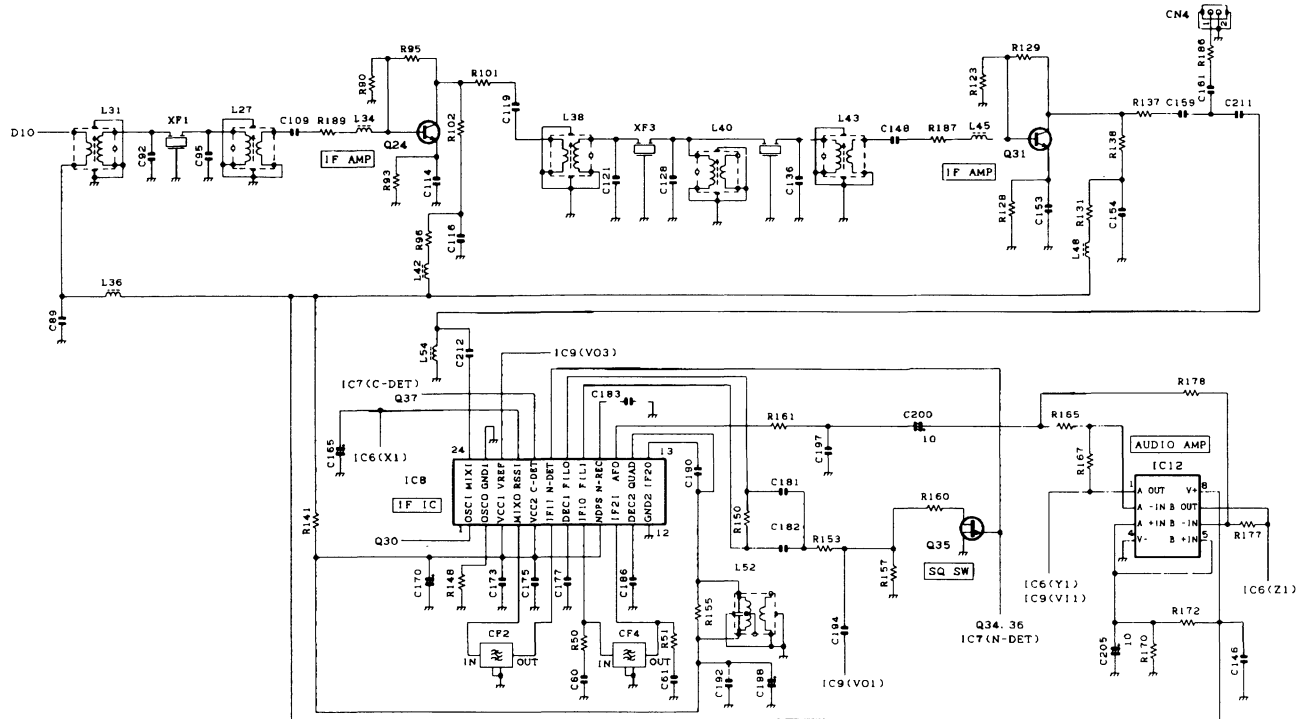

Fig.16 Wide IF circuit

## CIRCUIT DESCRIPTION

### (4) First oscillator PLL circuit

The first local oscillator PLL circuit consists of clap type VCO consisting of Q8 and Q9, fractional N type single-chip PLL IC IC1, buffer amplifier Q14, and high frequency amplifier Q3, Q1, Q5, and Q6. The first local oscillator is a lower heterodyne local oscillator with a receive frequency of 450.0000 to 480.0000 MHz. The VCO oscillator frequency is 376.95 to 406.95 MHz. One of the two VCOs, Q8, covers the range of 376.95 to 391.945 MHz, and Q9 covers the range of 391.95 to 406.95 MHz. One of the VCOs is selected by switching switching-transistors Q10, Q12, and Q13 by shift register IC3 output Q3.) The signal generated by Q8 or Q9 is fed to buffer amplifier Q14. The signal is isolated and is sent to high frequency amplifiers Q3 and Q23. The signal input to Q23 is amplified to the level required for IC1 prescaler input, harmonic

wave components are removed by a "pi" type two-step LPF, and the resulting signal goes to pin 5 of IC1. PLL IC IC1 divides the CN7 receive PLL reference signal 19.2MHz coming from the transmitter unit and the signal generated by the VCO and compares phases with a comparison frequency of 12.5 kHz. The detected phase difference signal is fed to the internal charge pump, converted to an analog signal (0 to 5 V), and output from the PHP pin. The analog signal output from the PHP pin is converted to a direct current voltage by a lag-lead type loop filter. The capacity of varicaps D2, D3, and D4 is varied by this direct current voltage to lock the VCO to the desired oscillator frequency. The signal input to Q3 is amplified to about 20 dBm by high frequency amplifier Q3, Q1, Q5, and fed to mixer DBM A1 as a first local oscillator signal.

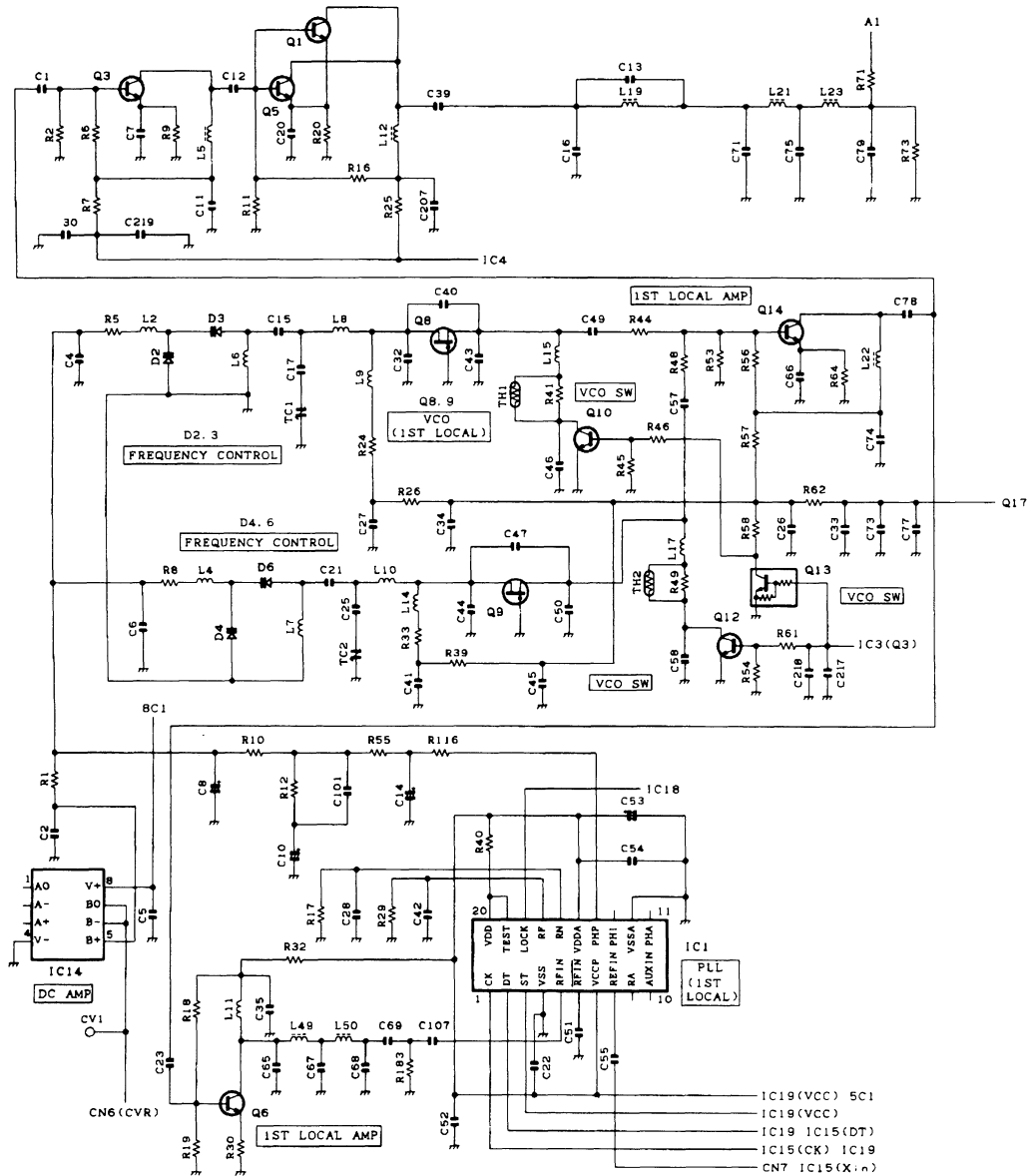

Fig.17 First oscillator PLL circuit

## CIRCUIT DESCRIPTION

### (5) Second oscillator PLL circuit

The second local oscillator PLL circuit consists of PLL IC IC15, crystal oscillator X1, oscillator FET Q21, buffer amplifier Q23, high frequency amplifier Q15, Q30, Q33, and emitter follower Q27. The VCO consists of no-adjustment type crystal oscillator circuit (Q21 and X1) (based on a Colpitts oscillator circuit) and varicap D9. The signal generated by the VCO is fed to buffer amplifier Q23. The signal is isolated by Q23 and fed to high frequency amplifier Q15 and emitter follower amplifier Q27. High frequency amplifier Q15 amplifies the signal to the level required for IC15 prescaler input, and outputs it to IC15 Fin (pin 20). IC15 divides the CN7 receive PLL reference signal 19.2MHz coming from the transmitter unit and the VCO-generated signal input to Fin and compares phases with a comparison frequency of 200 kHz. The detected phase

difference signal is converted to an analog signal (0 to 5 V) by the internal charge pump. The signal is output from the IC15 Do pin, and converted to a direct current voltage by a laglead type loop filter. The VCO varicap D9 is controlled by the direct current voltage to lock stably with the desired frequency 72.6 MHz. The signal input to emitter follower amplifier Q27 is isolated, and moved from the Q27 emitter to high frequency amplifier Q33, Q30. The signal is amplified to the level required for FM detection IC OSC1 input, and output to the OSC1 pin of each FM detection IC. The unlock detection signals from the two PLL circuits in the receiver unit are ANDed by IC18, and the resulting signal is sent to the CPU in the control unit from CN6 as receive PLL lock signal LDR.

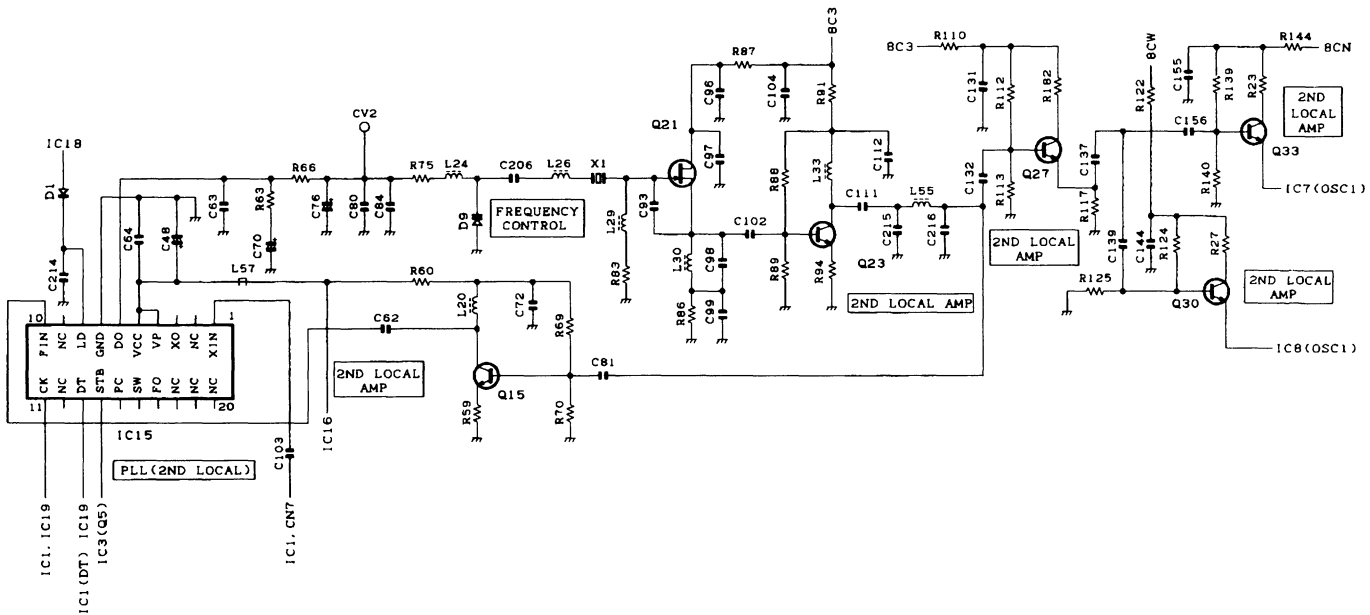

Fig.18 Second oscillator PLL circuit

### (6) Base band circuit

The base band signal circuit consists of HPF Q26 and Q28, switching diode D11, and digital transistor Q29. The level of the base band signal detected by the narrow and wide FM detection circuits is adjusted by the amplifier (B/2) of IC11, IC12. The active detection output is selected by Z0 and Z1 of multiplexer IC6. The amplified base band signal is output to

CN6 from IC6 "Z" pin as the DET signal. The level is adjusted by the amplifier (A/2) of IC11, IC12 and the active detection output is selected by Y0 and Y1 of multiplexer IC6. The sub-audio band components of the signal output from the "Y" pin are cut by the HPF of Q26 and Q28, the signal is switched by the squelch signal by D11 and Q29, and output from CN6 as the RA signal.

## CIRCUIT DESCRIPTION

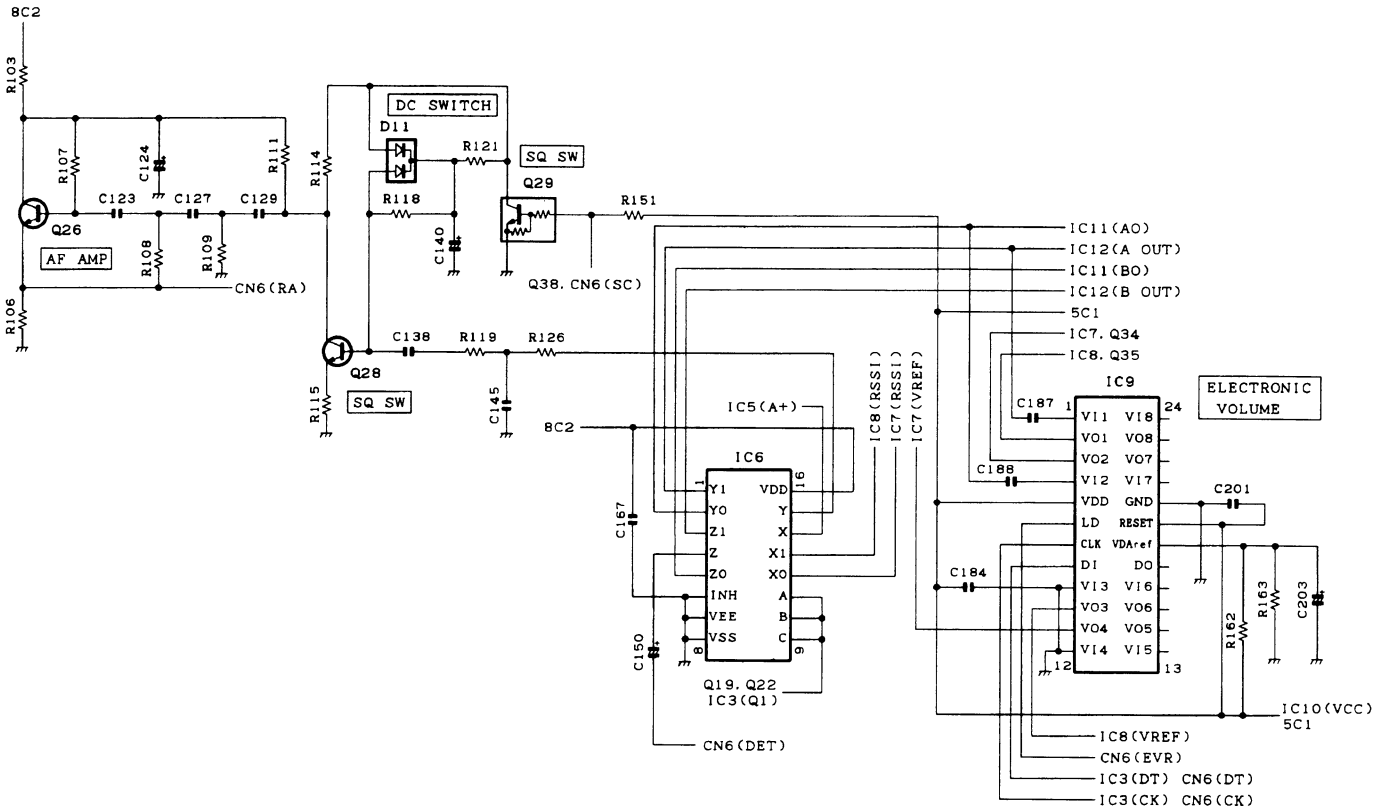

Fig.19 Base band circuit

### (7) Other circuits

The receiver circuit contains an EEPROM (IC10) like the transmitter circuit. Adjustment data for each unit is written into the EEPROM when adjustment ends. Therefore, even if the unit is moved to another set, no adjustment is required. IC2, IC4, IC13, IC16, and IC17 form a three-pin constant voltage power supply IC. Each circuit contains a power supply to isolate circuits. Q17 is a ripple filter for the power supplied to the first local oscillator PLL VCO. The RSSI signal for the active wide or narrow FM detection IC is selected by "X1, X0, X" of the

multiplexer IC6. The signal is output from connector CN6 through the operational amplifier buffer amplifier IC (A/2). IC3 is a shift register. IC3 switches between the two IF circuit power supplies and between the second local oscillator PLL strobe data and the first local oscillator PLL VCO according to the data from the CPU. Q16, Q18, Q19, Q20, and Q22 compose a switching transistor. It controls power supplies 8CN and 8CW for the two IF circuits.

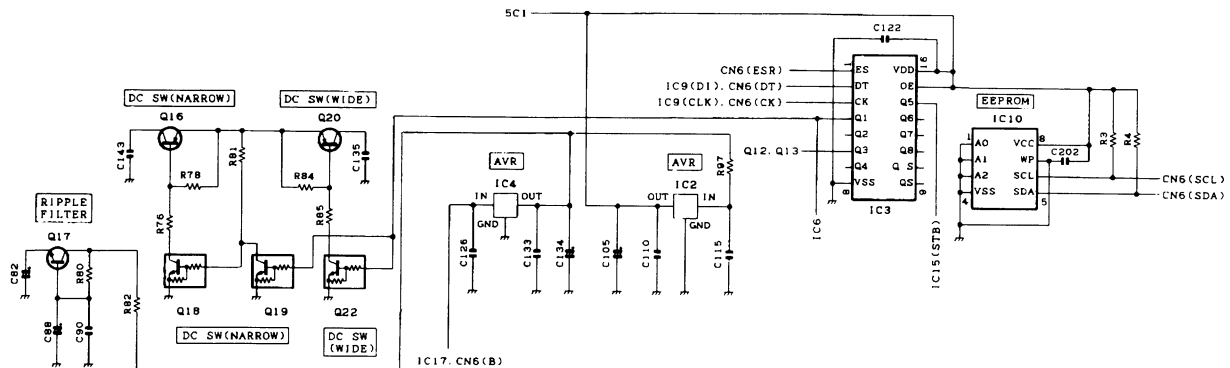

Fig.20 Other circuits

## CIRCUIT DESCRIPTION

### Control Circuit

The control unit (X53-381) consists of (1) CPU, (2) receive audio filter circuit, (3) LSD filter circuit, (4) AF PA circuit, (5) microphone amplifier circuit, (6) noise squelch circuit, (7) display circuit, (8) channel setting circuit, (9) RS-232C circuit, (10) external equipment connection circuit, and (11) other circuits.

#### (1) CPU

The CPU (IC10) is a single-chip microcomputer containing a 1Mbit flash ROM (128k x 8). The firmware can be modified easily. The CPU controls the transmitter unit, the receiver unit,

the control unit, and the display circuit and transfers data to or from external devices.

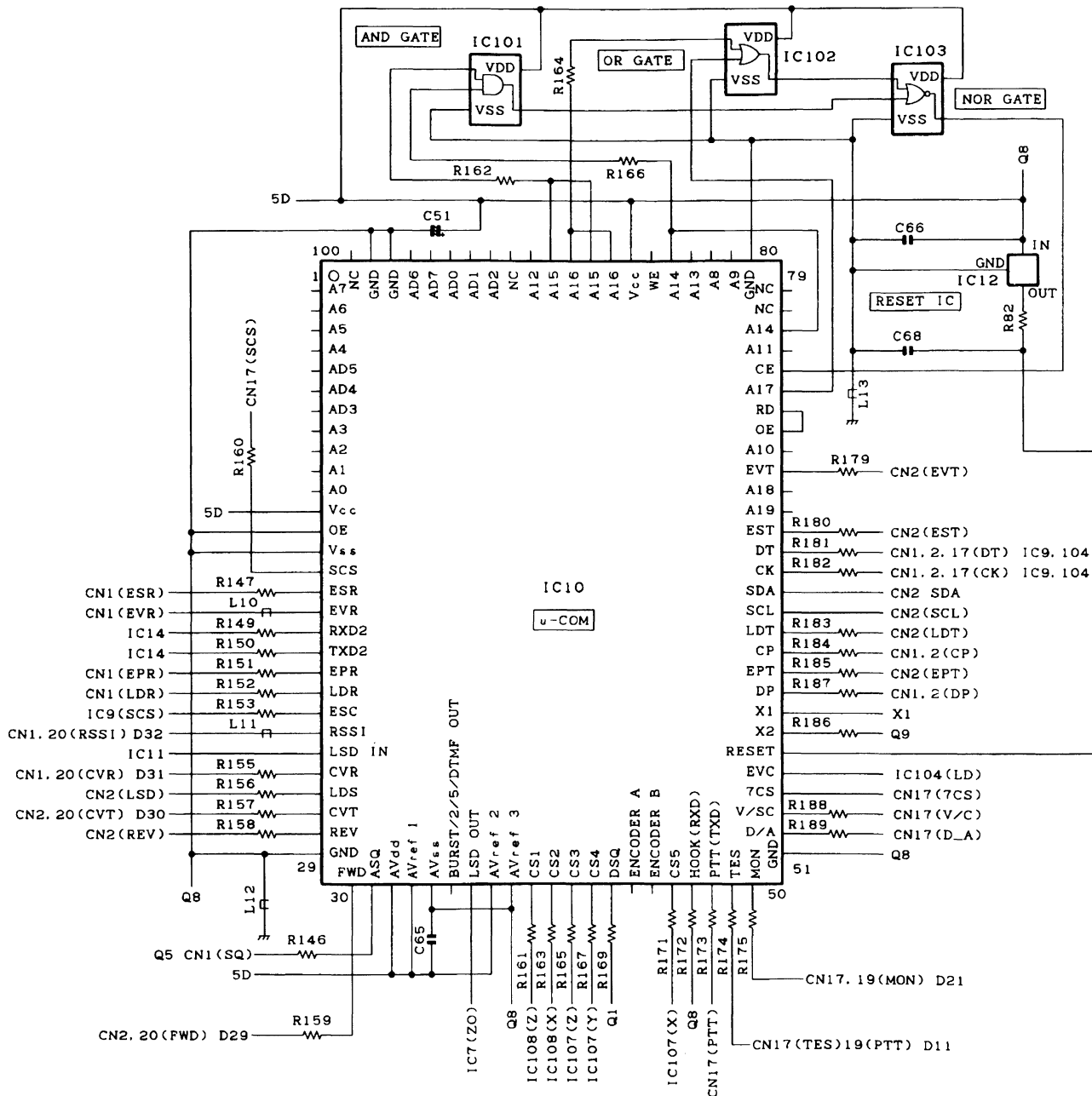

Fig.21 CPU

## CIRCUIT DESCRIPTION

### (2) Receive audio filter circuit

The receive audio filter circuit consists of operational amplifiers IC3 and IC5. The RA signal from the receiver unit (receive audio signal filtered by the receiver unit) passes through the second HPF ( $f_c=300$  Hz) in IC3 (A/2) and the twin T type notch filter ( $f_o=3$  kHz) in IC3 (B/2) to attenuate the signalling signal components under 300 Hz and prevent leakage of the signalling signal to the monitor audio. IC15 LFP ( $f_c=3$  kHz) cuts the high

frequency noise by low frequency pass characteristics. The signal passes through the volume adjustment variable resistor VR301 and goes to the AF PA circuit as the RAF signal. Its level is adjusted by V1 of electronic volume IC104, the signal passes through the operational amplifier IC105 (A/2) and is output from the CN19 D-sub 25-pin connector as the RA signal.

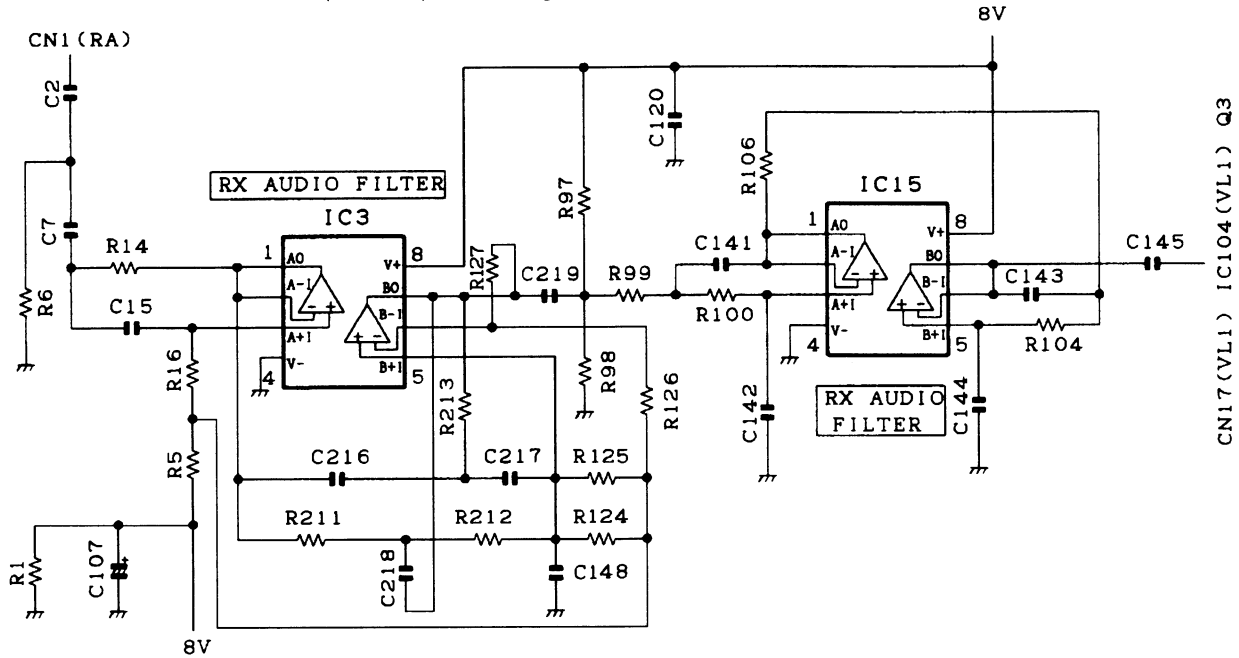

Fig.22 Receive audio filter circuit

### (3) LSD filter circuit

The IC11 LSD filter circuit is a pre-filter required to process the receive signal LSD (low speed data) by CPU IC10 for future upgrading. The TKR-830 does not use it.

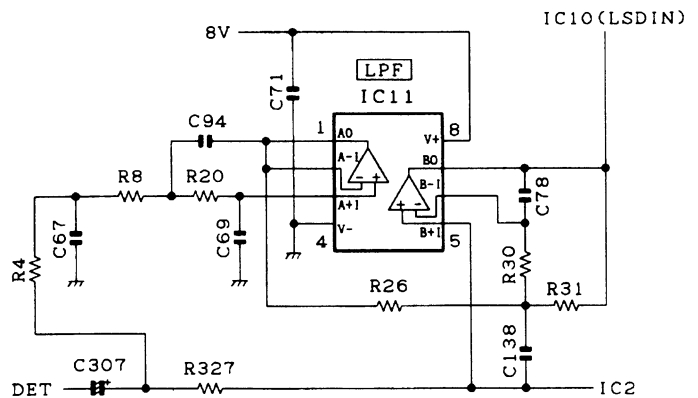

Fig.23 LSD filter circuit

## CIRCUIT DESCRIPTION

### (4) AF PA circuit

The IC8 AF PA circuit is an AF amplifier for driving speakers to monitor receive audio signals. The 4W audio output can be provided to the external speakers when power supply voltage 13.8 V/4 ohms is supplied by the 15-pin test connector "SPO.SPG" on the rear panel. The output impedance of the internal speaker is adjusted to provide an audio output of about 0.2 W when the internal speaker installed on the TKR-830 front panel is used.

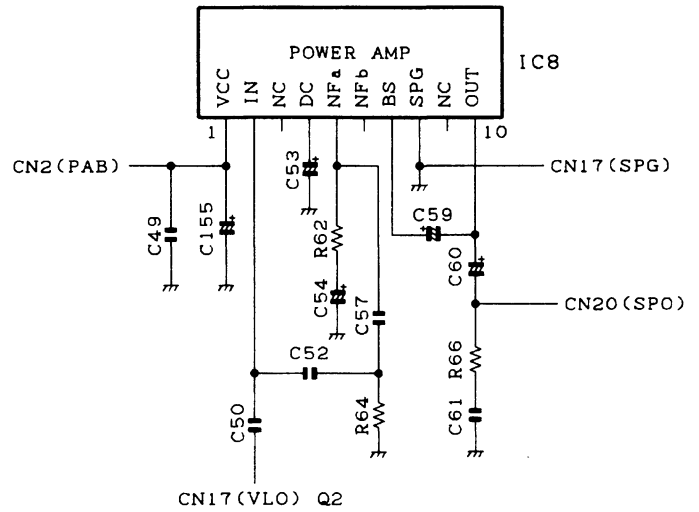

Fig.24 AF PA circuit

### (5) Microphone amplifier circuit

The display circuit contains 7-segment LED D212, D213 (orange: see page 9), D203 (green: power supply), D201 (red: transmission), D202 (green: busy), two-color LED D210 (green: internal/red: external reference state) to display channels and states.

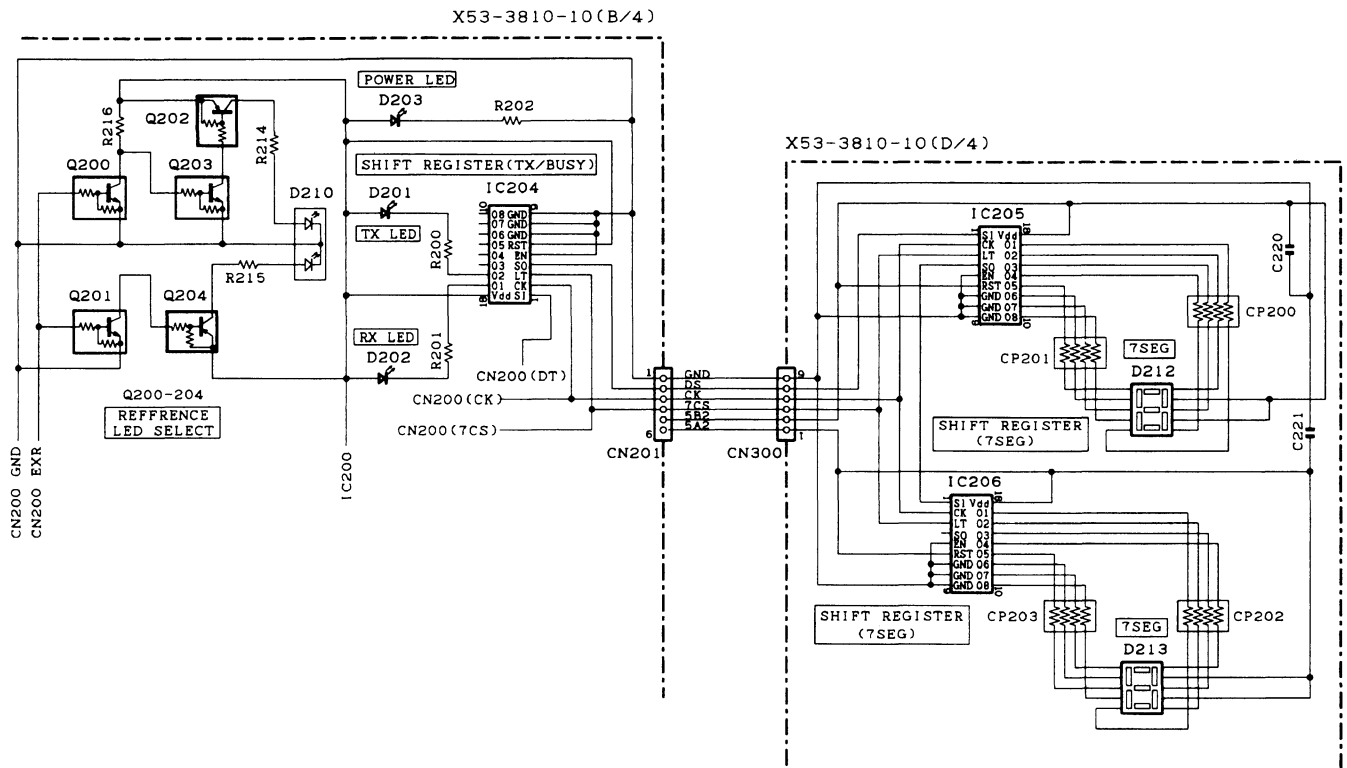

Fig.25 Microphone amplifier circuit

## CIRCUIT DESCRIPTION

### (6) Noise squelch circuit

The noise squelch circuit in the control unit is a pulse count type noise squelch circuit designed for future upgrading. The operational amplifier IC2 (A/2) HPF and IC2 (B/2) inverting amplifier convert high frequency noise components to pulse signals. The CPU counts the pulses to operate noise squelch. The TKR-830 does not use this circuit.

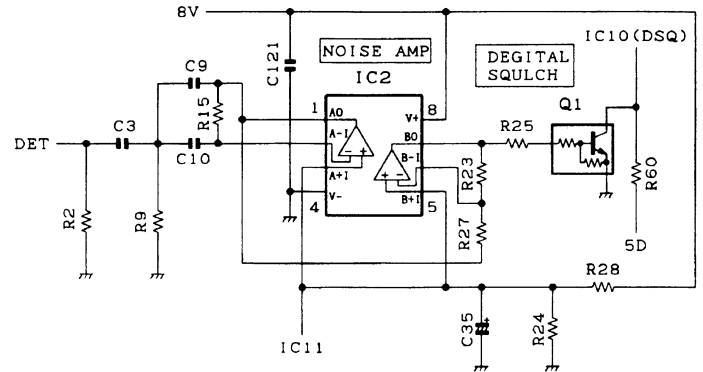

Fig.26 Noise squelch circuit

### (7) Display circuit

The microphone amplifier circuit process the audio signal when modulating from the local microphone on the TKR-830 front panel or from the TA pin of the D-sub connector on the rear panel. It consists of AGC amplifier IC13 (B/2), Q7, HPF IC13 (A/2), amplifier Q4, twin T BEF IC5 (B/2), pre-emphasis/limiter (B/2), and splatter filter IC4. The audio signal coming from J201 of the local microphone passes through CN17 pin 25 (MI) and goes to the AGC amplifier IC13 (1/2), Q7. The audio signal is amplified and the gain is automatically controlled. The signal is then fed to "XO" of multiplexer IC7. (IC7 is controlled according to data from the CPU. When the local microphone is used, "XO" and "X" conduct.) The audio signal input to "XO" is output from "X" to the amplifier Q4. Q4 fine-adjusts the amplitude of the audio signal. The signal passes through the HPF, twin T BEF, pre-emphasis/limiter, and splatter filter. The HPF and twin T BEF damp the components under 300 Hz with the  $f_c=300$  Hz high pass characteristics and  $f_o=210$  Hz notch characteristics to prevent blocking by the signalling audio

signal. The pre-emphasis/limiter circuit gives the audio signal of 300 Hz to 3 kHz +6dB/octav frequency characteristics and emphasizes high frequency to improve the signal-to-noise ratio. The limiter circuit limits the amplitude. The splatter filter attenuates high frequency components and prevents spreading of the occupied frequency bandwidth by the high frequency audio signal. The splatter filter circuit contains two Chebyshev secondary filters to provide  $f_c=3$  kHz and the damping characteristics of -24 dB/octave. The audio signal processed by the microphone amplifier is output from connector CN2 to the transmitter unit as modulation signal "MOD". When the signal is modulated from the TA pin of the D-sub 25-pin connector, the audio signal TA is amplified by the amplifier IC106 (A/2), and its level is adjusted by V5 of the electronic volume IC104. The signal passes through "YO", "Y", and "X1" of multiplexer IC7 and is output to "X". The route of the signal after "X" is the same as that for the local microphone.

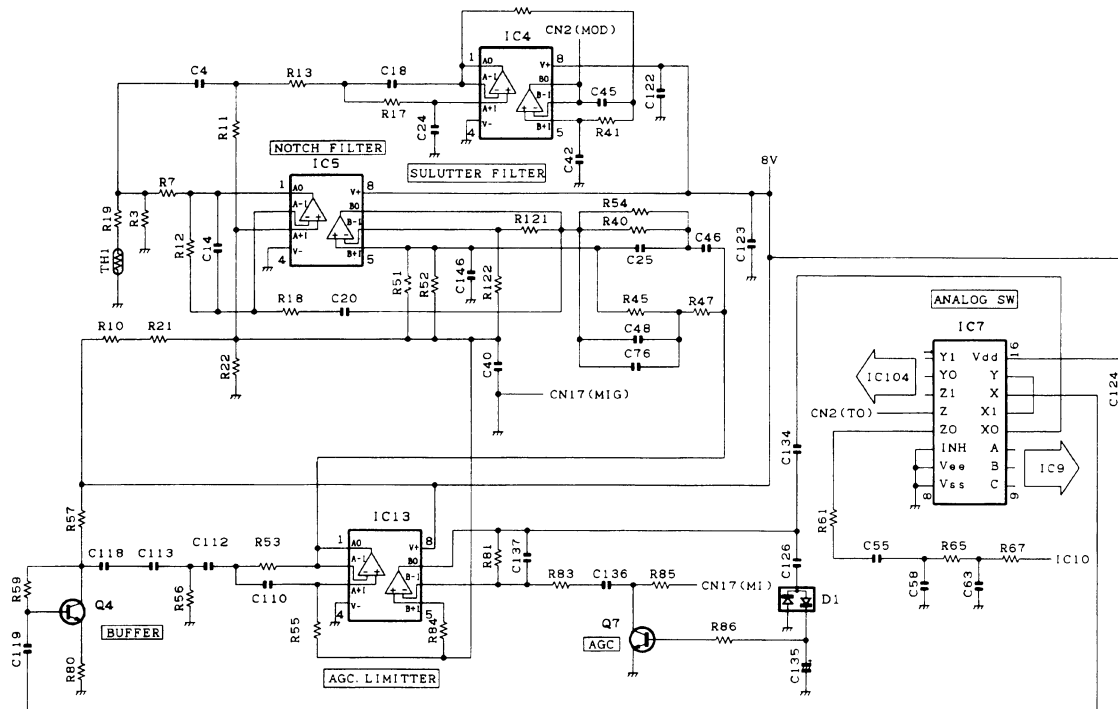

Fig.27 Display circuit



## CIRCUIT DESCRIPTION

### (8) Channel setting circuit

The channel setting circuit consists of DIP switch S1, S2, and multiplexer IC107, IC108. Channels 1 to 32 can be selected according to the 5-bit data of DIP switch S1, S2 or the 5-bit data input from the D-sub 25-pin connector. One of the data is

selected for channel setting according to the logic of the I/E pin of the D-sub 25-pin connector on the rear panel. If I/E is "H", the internal switch is selected. (see page 8) When it is "L", the external data is selected.

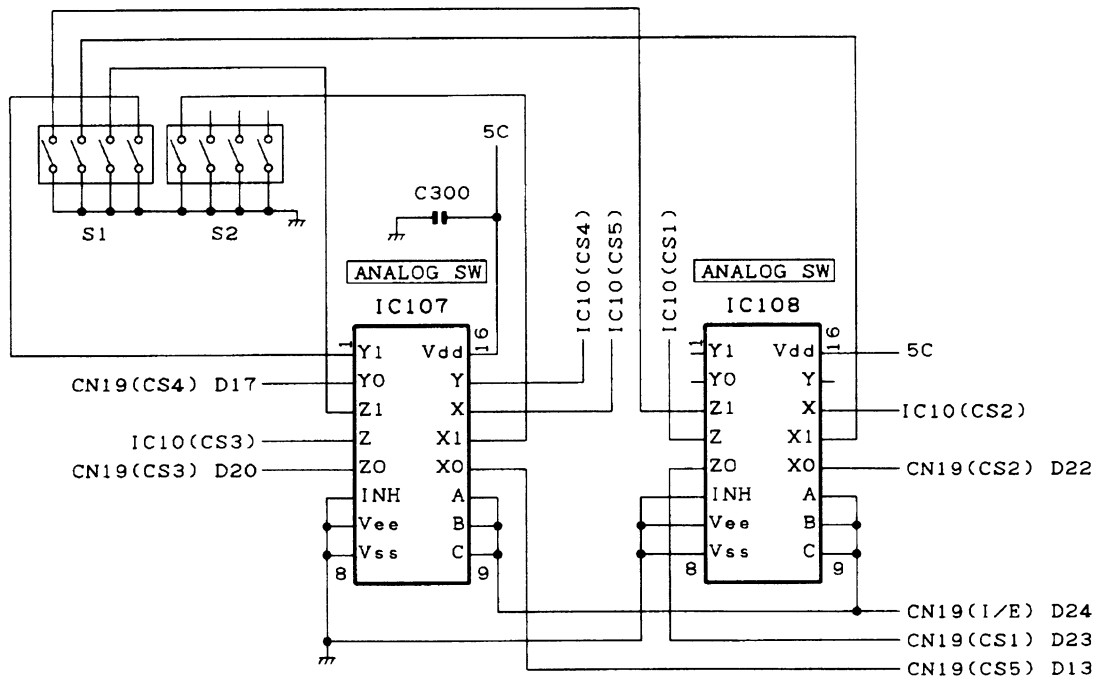

Fig.28 Channel setting circuit

### (9) RS-232C circuit

The RS-232C circuit connects the RS-232C serial port of the personal computer directly to the TKR-830 to perform FPU operation. The FPU can also be operated by connecting a programming cable (KPG-46) to the local microphone on the front panel. When the D-sub connector on the rear panel is used, the programming cable is not required. The 232C driver IC (IC14) changes TTL-232C levels. The FPU (KPG-47D) has

a new transmitter/receiver circuit monitor function (transmission: transmission progressive power display, transmission reflective power display, transmit main PLL lock voltage display; reception: RSSI display, receive main PLL lock voltage display). Data required for this function is also transferred through RS-232C. The firmware can only be modified by the local microphone on the front panel.

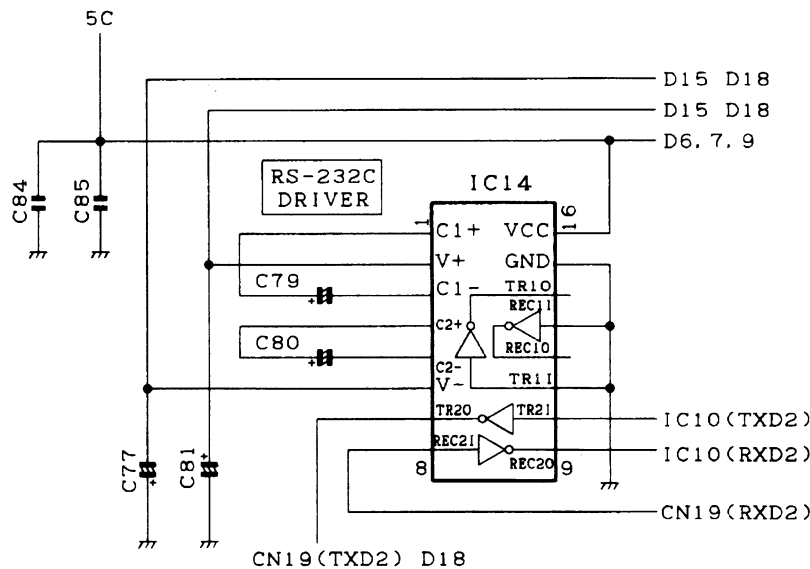

Fig.29 RS-232C circuit

## CIRCUIT DESCRIPTION

### (10) External equipment connection circuit

The external equipment connection circuit has CN19 for RS-232C: RXD2/TXD2, external modulation input: TD (signalling)/TA (audio), receive output: RD (signalling + audio)/RA (audio), speaker mute input: SPM, monitor control input: MON, transmission input: PTT, squelch output: SC, channel control: IN/EXT SW, and external channel input: EC1/EC2/EC3/EC4/

EC5. CN20 has receive output: RD (signalling + audio), receive signal strength output: RSSI, transmit main PLL lock voltage output: TXCV, receive first local oscillator PLL lock voltage output: RXCV, voltage check output: VC, transmit progressive power value output: FWD, and reference frequency display output: EXTREF.

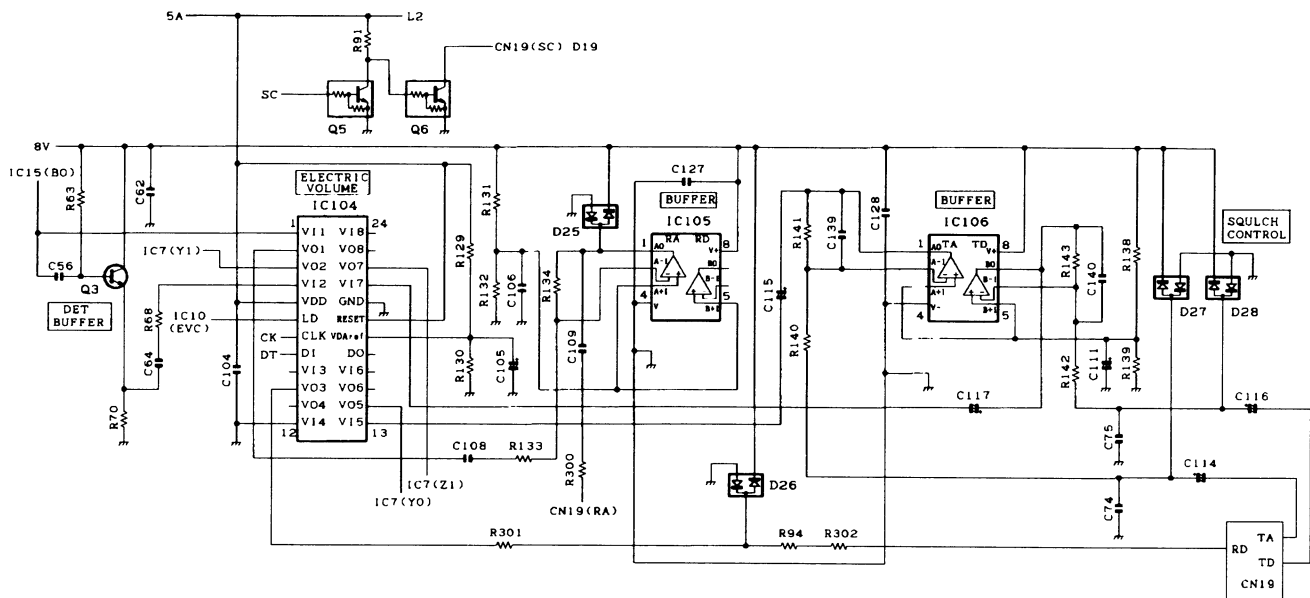

Fig.30 External equipment connection circuit

### (11) Other circuits

IC1, IC6, IC200, IC201, and IC202 form a three-pin constant voltage power supply IC. It provides power to the control unit circuits. IC101, IC102, and IC103 form a logic IC used to switch the banks of the flash ROM. IC9 is a shift register that shifts the clock, performs AF mute, and controls the multiplexer IC according to the data from the CPU. IC109 is a NAND logic

IC. This IC NANDs the AF mute signal from IC109 and the mute signal SPM from CN19 and turns Q2 "ON" or "OFF" to control muting of the input signal of the AF PA. IC204, IC205, and IC206 compose a shift register that controls display according to the data from the CPU.

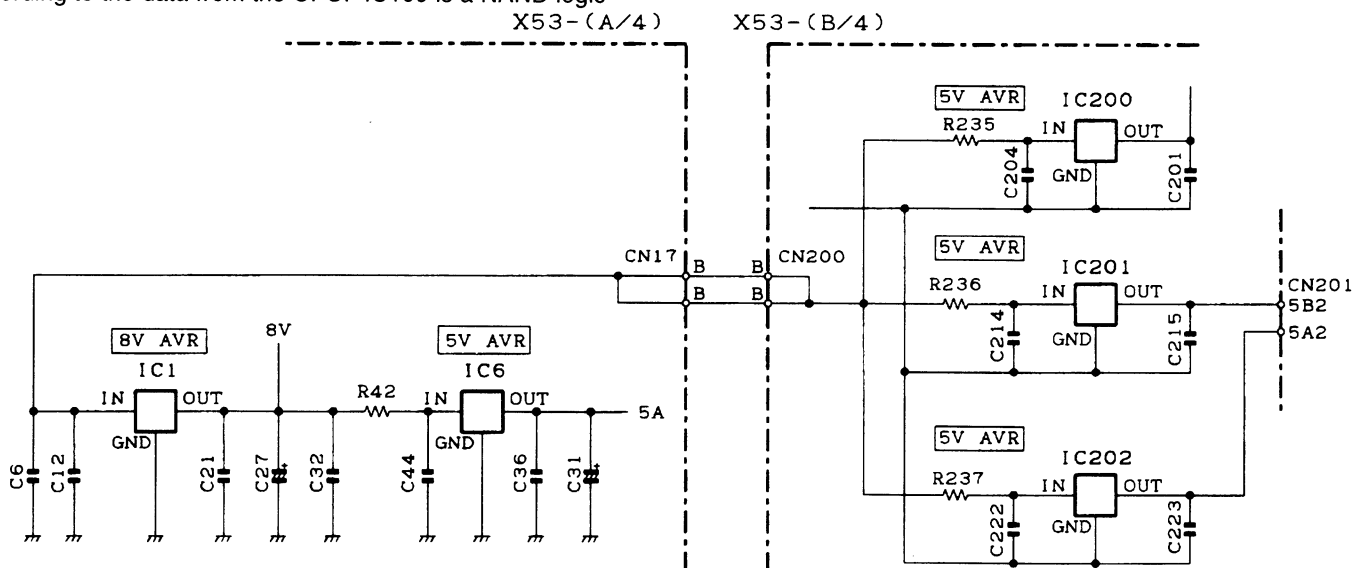

Fig.31 Other circuits

## SEMICONDUCTOR DATA

## Microprocessor : MC-8800-804 (Control Unit IC10)

## ■ Pin function

Pin No.	Port name	I/O	Function
1~4	A7~A4	-	Flash memory address bus
5~7	AD5~AD3	-	Flash memory address & data bus
8~11	A3~A0	-	Flash memory address bus
12	Vcc	-	+5V
13	OE		Address latch output enable(GND)
14	Vss	-	GND
15	SCS	I	NC : Scan switch
16	ESR	O	RX shift register data strobe output
17	EVR	O	RX D/A converter IC data strobe output
18	RXD2	I	Serial interface input 2(ex. PC)
19	TXD2	O	Serial interface output 2(ex. PC)
20	EPR	O	RX PLL data strobe output
21	LDR	I	RX PLL lock detect input
22	ESC	O	Control shift register data strobe output
23	RSSI	I	RSSI level input
24	LSD IN	I	Low speed data input (QT/DQT/LTR)
25	CVR	I	RX VCO voltage input
26	LDS	I	Sub PLL lock detect input
27	CVT	I	TX VCO voltage input
28	REV	I	Reverse power voltage input
29	GND	-	GND
30	FWD	I	Forward power voltage input
31	ASQ	I	Analogue squelch input
32	AVdd	-	+5V
33	AVref1	-	+5V
34	AVss	-	GND
35	BURST/2/5/ DTMFOUT	O	Burst /2/5/DTMF output
36	LSD OUT	O	Low speed data output(QT/DQT/LTR)
37	AVref2	-	+5V
38	AVref3	-	GND
39	CS1	I	Channel select 1
40	CS2	I	Channel select 2
41	CS3	I	Channel select 3
42	CS4	I	Channel select 4
43	DSQ	I	NC : Digital Squelch input
44	ENCODE A	I	NC : Encoder pulse input A
45	ENCODE B	I	NC : Encoder pulse input B
46	CS5	I	Channel select 5
47	HOOK(RXD)	I	serial interface input 1(ex.PC)
48	PTT(TXD)	I/O	PTT switch input Serial interface output 1(ex. PC)

Pin No.	Port name	I/O	Function
49	TES	I	Test switch input
50	MON	I	Monitor switch input
51	GND	-	GND
52	D/A	I	NC : D/A switch input
53	V/SC	I	NC : Voice scrambler switch input
54	7CS	O	7-segment LED data strobe
55	EVC	O	Control D/A converter IC data strobe output
56	RESET	I	Microcomputer reset input (reset active : L)
57,58	X2,X1	-	14.754MHz (System clock)
59	DP	O	PLL data output
60	EPT	O	TX PLL data strobe output
61	CP	O	PLL clock output
62	LDT	I	TX PLL lock detect input
63	SCL	O	Serial EEPROM clock output
64	SDA	I/O	Serial EEPROM data input/output
65	CK	O	Common clock output
66	DT	O	Common data output
67	EST	O	TX shift register data strobe output
68,69	A19,A18	-	Flash memory address bus
70	EVT	O	TX D/A converter IC data strobe output
71	A10	-	Flash memory address bus
72	OE	-	Flash memory output enable
73	RD	-	Flash memory RD bus
74	A17	-	Flash memory address bus
75	CE	-	Flash memory chip enable
76,77	A11,A14	-	Flash memory address bus
78,79	NC	-	Not used (open)
80	GND	-	GND
81,82	A9,A8	-	Flash memory address bus
83,84	A13,A14	-	Flash memory address bus
85	WE	-	Flash memory WE bus
86	Vcc	-	+5V
87,88	A16,A15	-	Flash memory address bus
89,90	A16,A15	-	Flash memory address bus
91	A12	-	Flash memory address bus
92	NC	-	Not used (open)
93~95	AD2~AD0	-	Flash memory address & data bus
96,97	AD7,AD6	-	Flash memory address & data bus
98,99	GND	-	GND
100	NC	-	Not used (open)

# TKR-830

## DESCRIPTION OF COMPONENTS

### CONTROL UNIT (X53-3810-10)

CIRCUIT SYMBOL	NUMBER	DESCRIPTION
D1	DIODE	DET
D6	DIODE	SURGE PROTECT
D7	DIODE	SURGE PROTECT
D8	DIODE	SURGE PROTECT
D9	DIODE	SURGE PROTECT
D11	DIODE	SURGE PROTECT
D13	DIODE	SURGE PROTECT
D15	DIODE	SURGE PROTECT
D17	DIODE	SURGE PROTECT
D18	DIODE	SURGE PROTECT
D20	DIODE	SURGE PROTECT
D21	DIODE	SURGE PROTECT
D22	DIODE	SURGE PROTECT
D23	DIODE	SURGE PROTECT
D24	DIODE	SURGE PROTECT
D25	DIODE	SURGE PROTECT
D26	DIODE	SURGE PROTECT
D27	DIODE	SURGE PROTECT
D28	DIODE	SURGE PROTECT
D29	DIODE	SURGE PROTECT
D30	DIODE	SURGE PROTECT
D31	DIODE	SURGE PROTECT
D32	DIODE	SURGE PROTECT
D200	VARISTOR	CURRENT PROTECT
D201	LED	TX LED
D202	LED	RX LED
D203	LED	POWER LED
D207	DIODE	SURGE PROTECT
D208	DIODE	SURGE PROTECT
D209	DIODE	SURGE PROTECT
D210	LED	REFERENCE LED
D212	LED ASS'Y	7SEG
D213	LED ASS'Y	7SEG
D214	DIODE	SURGE PROTECT
IC1	IC	8V AVR
IC2	IC	NOISE AMP
IC3	IC	RX AUDIO FILTER
IC4	IC	SPLUTTER FILTER
IC5	IC	NOTCH FILTER
IC6	IC	5V AVR
IC7	IC	AUDIO SW
IC8	IC	POWER AMP
IC9	IC	SHIFT REGISTER
IC10	IC	u-COM
IC11	IC	LPF
IC12	IC	RESET IC
IC13	IC	AGC, LIMITTER
IC14	IC	RS-232C DRIVER
IC15	IC	RX AUDIO FILTTER
IC101	IC	AND GATE
IC102	IC	OR GATE
IC103	IC	NOR GATE

CIRCUIT SYMBOL	NUMBER	DESCRIPTION
IC104	IC	ELECTRIC VOLUME
IC105	IC	BUFFER
IC106	IC	BUFFER
IC107	IC	ANALOG SW
IC108	IC	ANALOG SW
IC109	IC	NAND GATE
IC200	IC	5V AVR
IC201	IC	5V AVR
IC202	IC	5V AVR
IC204	IC	SHIFT REGISTER(TX/BUSY)
IC205	IC	SHIFT REGISTER(7SEG)
IC206	IC	SHIFT REGISTER(7SEG)
Q1	TRANSISTOR	DEGITAL SQUALCH
Q2	TRANSISTOR	AUDIO MUTE
Q3	TRANSISTOR	DET BUFFER
Q4	TRANSISTOR	BUFFER
Q5	TRANSISTOR	SQUALCH CONTROL
Q6	TRANSISTOR	SQUALCH CONTROL
Q7	TRANSISTOR	AGC
Q8	TRANSISTOR	HOOK
Q9	TRANSISTOR	CLOCK SHIFT
Q10	TRANSISTOR	HOOK
Q200	TRANSISTOR	REFERENCE LED SELECT
Q201	TRANSISTOR	REFERENCE LED SELECT
Q202	TRANSISTOR	REFERENCE LED SELECT
Q203	TRANSISTOR	REFERENCE LED SELECT
Q204	TRANSISTOR	REFERENCE LED SELECT
Q211	TRANSISTOR	REFERENCE MONITER SELECT

## DESCRIPTION OF COMPONENTS

## RX UNIT (X55-3040-10)

CIRCUIT SYMBOL	NUMBER	DESCRIPTION
D1	DIODE, LOCK DETECT	
D2	VARIABLE CAPACITANCE DIODE	FREQUENCY CONTROL
D3	VARIABLE CAPACITANCE DIODE	FREQUENCY CONTROL
D4	VARIABLE CAPACITANCE DIODE	FREQUENCY CONTROL
D6	VARIABLE CAPACITANCE DIODE	FREQUENCY CONTROL
D9	VARIABLE CAPACITANCE DIODE	FREQUENCY CONTROL
D10	DIODE,	IF SWITCH (WIDE/NARROW)
D11	DIODE,	DC SWITCH
IC1	IC	PLL(1ST LOCAL)
IC2	IC	AVR
IC3	IC	LATCH
IC4	IC	AVR
IC5	IC	DC AMP
IC6	IC	AUDIO SWITCH
IC7	IC	IF IC
IC8	IC	IF IC
IC9	IC	ELECTRONIC VOLUME
IC10	IC	EEPROM
IC11	IC	AUDIO AMP
IC12	IC	AUDIO AMP
IC13	IC	AVR
IC14	IC	DC AMP
IC15	IC	PLL (2ND LOCAL)
IC16	IC	AVR
IC17	IC	AVR
IC18	IC	AND GATE (LOCK DE)
IC19	IC	NOT GATE
Q1	TRANSISTOR	1ST LOCAL AMP
Q3	TRANSISTOR	1ST LOCAL AMP
Q5	TRANSISTOR	1ST LOCAL AMP
Q6	TRANSISTOR	1ST LOCAL AMP
Q7	TRANSISTOR	FIRST AMPLIFIER
Q8	FET	VCO (1ST LOCAL)
Q9	FET	VCO (1ST LOCAL)
Q10	TRANSISTOR	VCO SWITCH
Q12	TRANSISTOR	VCO SWITCH
Q13	TRANSISTOR	VCO SWITCH
Q14	TRANSISTOR	1ST LOCAL AMP
Q15	TRANSISTOR	2ND LOCAL AMP
Q16	TRANSISTOR	DC SWITCH(NARROW)
Q17	TRANSISTOR	RIPPLE FILTER
Q18	TRANSISTOR	DC SWITCH(NARROW)
Q19	TRANSISTOR	DC SWITCH(NARROW)
Q20	TRANSISTOR	DC SWITCH(WIDE)
Q21	FET	VCO (2ND)
Q22	TRANSISTOR	DC SWITCH(WIDE)
Q23	TRANSISTOR	2ND LOCAL AMP

CIRCUIT SYMBOL	NUMBER	DESCRIPTION
Q24	TRANSISTOR	IF AMP
Q25	TRANSISTOR	IF AMP
Q26	TRANSISTOR	AF AMP
Q27	TRANSISTOR	2ND LOCAL AMP
Q28	TRANSISTOR	SQ SWITCH
Q29	TRANSISTOR	SQ SWITCH
Q30	TRANSISTOR	2ND LOCAL AMP
Q31	TRANSISTOR	IF AMP
Q32	TRANSISTOR	IF AMP
Q33	TRANSISTOR	2ND LOCAL AMP
Q34	FET	SQ SWITCH
Q35	FET	SQ SWITCH
Q36	TRANSISTOR	OR GATE (SQ CONT)
Q37	TRANSISTOR	OR GATE (SQ CONT)
Q38	TRANSISTOR	NOT GATE(SQ CONT)

# TKR-830

## DESCRIPTION OF COMPONENTS

### TX UNIT (X56-3030-10)

CIRCUIT SYMBOL	NUMBER	DESCRIPTION
D1	VARIABLE CAPACITANCE DIODE	FREQUENCY CONTROL
D2	VARIABLE CAPACITANCE DIODE	FREQUENCY CONTROL
D3	VARIABLE CAPACITANCE DIODE	FREQUENCY CONTROL
D4	VARIABLE CAPACITANCE DIODE	FREQUENCY CONTROL
D5	VARIABLE CAPACITANCE DIODE	MODULATION
D6	VARIABLE CAPACITANCE DIODE	MODULATION
D7	DIODE	RF SWITCH
D8	DIODE	CURRENT CONTROL
D10	DIODE	RF SWITCH
D11	DIODE	CUEERNT STEERING
D12	DIODE	CUEERNT STEERING
D101	DIODE	RF SWITCH
D103	DIODE	RF SWITCH
D201	VARIABLE CAPACITANCE DIODE	FREQUENCY CONTROL
D202	VARIABLE CAPACITANCE DIODE	FREQUENCY CONTROL
D203	VARIABLE CAPACITANCE DIODE	MODULATION
D205	DIODE	DET
D206	VARIISTOR	CURRENT PROTECT
D207	VARIISTOR	CURRENT PROTECT
D240	VARIABLE CAPACITANCE DIODE	FREQUENCY CONTROL
D301	ZENER DIODE	VOLTAGE CONTROL
D302	DIODE	CURRENT STEERING
D303	SURGE ABS ORBER	SURGE PROTECTOR
D304	DIODE	CURRENT STEERING
D305	DIODE	REVERCE CONNECT PROTECTOR
D306	DIODE	DET
D308	DIODE	DET
D310	VARIISTOR	CURRENT PROTECTOR
D311	VARIISTOR	CURRENT PROTECTOR
IC1	IC	AVR
IC2	IC	AVR
IC3	IC	ELECTRIC VOLUME
IC4	IC	SHIFT REGISTOR
IC100	IC	AVR
IC101	IC	PLL
IC103	IC	AVR
IC105	IC	SUMMING AMP
IC106	IC	EEPROM
IC108	IC	AVR
IC109	IC	BUFFER
IC110	IC	AVR

CIRCUIT SYMBOL	NUMBER	DESCRIPTION
IC201	IC	PLL
IC202	IC	PLL
IC203	IC	DC AMP
IC204	IC	COMPARATOR
IC205	IC	BUFFER
IC301	IC	POWER MODULE
IC302	IC	COMPARATOR
IC303	IC	DC AMP
Q1	FET	OSC
Q2	FET	OSC
Q3	TRANSISTOR	DC SWITCH
Q4	TRANSISTOR	DC SWITCH
Q5	FET	DC SWITCH
Q6	TRANSISTOR	BUFF AMP
Q7	TRANSISTOR	RIPPLE FILTER
Q8	TRANSISTOR	DC SWITCH
Q9	TRANSISTOR	RF AMP
Q10	TRANSISTOR	DC SWITCH
Q11	TRANSISTOR	DC SWITCH
Q12	TRANSISTOR	DC SWITCH
Q13	TRANSISTOR	RF AMP
Q14	TRANSISTOR	RF AMP
Q15	FET	BUFF AMP
Q16	TRANSISTOR	DC SWITCH
Q17	TRANSISTOR	DC AMP
Q18	TRANSISTOR	DC SWITCH
Q102	TRANSISTOR	BUFF AMP
Q106	TRANSISTOR	DUBLER
Q107	TRANSISTOR	RF AMP
Q110	TRANSISTOR	DC SWITCH
Q111	TRANSISTOR	DC SWITCH
Q112	FET	DC SWITCH
Q113	FET	DC SWITCH
Q114	TRANSISTOR	DC SWITCH
Q115	TRANSISTOR	BUFF AMP
Q201	TRANSISTOR	OSC
Q202	TRANSISTOR	BUFF AMP
Q203	TRANSISTOR	DC SWITCH
Q205	TRANSISTOR	RF AMP
Q206	FET	DC SWITCH
Q240	TRANSISTOR	OSC
Q241	TRANSISTOR	BUFF AMP
Q301	TRANSISTOR	DC AMP
Q302	TRANSISTOR	DC SWITCH
Q304	TRANSISTOR	DC SWITCH
Q305	TRANSISTOR	DC SWITCH

## PARTS LIST

\* New Parts.  $\Delta$  indicates safety critical components.  
 Parts without **Parts No.** are not supplied.  
 Les articles non mentionnes dans le **Parts No.** ne sont pas fournis.  
 Teile ohne **Parts No.** werden nicht geliefert.

L: Scandinavia      K: USA      P: Canada  
 Y: PX (Far East, Hawaii)      T: England      E: Europe  
 Y: AAFES (Europe)      X: Australia      M: Other Areas

## TKR-830

Ref. No.	Address	New parts	Parts No.	Description	Destination	Ref. No.	Address	New parts	Parts No.	Description	Destination
<b>TKR-830</b>											
1	3A	*	A62-0587-03	PANEL (FRONT)		D210			B30-0864-05	LED (RE/EXT)(GR/INT)	
2	3B	*	B11-1192-04	FILTER (LED)		D212,213			LA301DB	LED ASSY	
3		*	B11-1202-04	FILTER (7 SEG)		C1			CC73GCH1H101J	CHIP C 100PF J	
4		*	B62-1010-00	INSTRUCTION MANUAL		C2			CK73GB1H562J	CHIP C 5600PF J	
5	1A	*	E23-1115-04	GROUND TERMINAL(FINAL)		C3			CC73GCH1H101J	CHIP C 100PF J	
6	2C	*	E30-3343-15	DC CORD		C4			CK73EB1C105K	CHIP C 1.0UF K	
7		*	E30-3344-05	DC CORD (ACCESSORY)		C5			CC73GCH1H101J	CHIP C 100PF J	
8		*	E31-3228-05	LEAD WIRE WITH CONNECTOR		C6			CK73GB1H102K	CHIP C 1000PF K	
9	2B	*	E37-0712-05	FLAT CABLE (CONT-TX,RX)		C7			CK73GB1H562J	CHIP C 5600PF J	
10	1B	*	E37-0713-05	FLAT CABLE (TX-FINAL)		C8			CC73GCH1H101J	CHIP C 100PF J	
11	2D	*	E37-0715-05	LEAD WIRE WITH CONNECTOR (25P)		C9			CC73GCH1H180J	CHIP C 18PF J	
12	3B	*	E37-0716-05	LEAD WIRE WITH CONNECTOR		C10,11			CC73GCH1H101J	CHIP C 100PF J	
13	3B	*	E37-0717-05	LEAD WIRE WITH CONNECTOR (SP)		C12			CK73FB1E104K	CHIP C 0.10UF K	
14	2C	*	E37-0718-05	LEAD WIRE WITH CONNECTOR (BNC)		C13			CC73GCH1H101J	CHIP C 100PF J	
15	1B	*	E37-0719-05	LEAD WIRE WITH CONNECTOR TX-RX		C14			CC73GCH1H330J	CHIP C 33PF J	
16	1B	*	E37-0720-05	LEAD WIRE WITH CONNECTOR		C15			CK73GB1H562J	CHIP C 5600PF J	
17	2D	*	E37-0721-05	LEAD WIRE WITH CONNECTOR (15P)		C16,17			CC73GCH1H101J	CHIP C 100PF J	
18	3B	*	E37-0780-05	LEAD WIRE WITH CONNECTOR		C18			CK73GB1H561K	CHIP C 560PF K	
19	1B	*	E37-0791-15	LEAD WIRE WITH TERMINAL DC(+)		C19			CC73GCH1H101J	CHIP C 100PF J	
20	2D		F06-4027-05	FUSE(BLADE) (4A/32V)		C20			CK73GB1H472K	CHIP C 4700PF K	
21	2C	*	F10-2296-04	SHIELDING PLATE (RX,BACK)		C21			CK73GB1E103K	CHIP C 0.010UF K	
22	2C	*	F10-2297-04	SHIELDING PLATE (RX,PARTITION)		C22			CC73GCH1H101J	CHIP C 100PF J	
23	1B		G02-0576-14	FLAT SPRING		C23			CK73EB1C105K	CHIP C 1.0UF K	
24	2C	*	G02-0829-14	FLAT SPRING		C24			CK73GB1H331K	CHIP C 330PF K	
25	2C	*	G02-0831-04	FLAT SPRING (HELICAL UPPER)		C25			CK73GB1H272J	CHIP C 2700PF J	
26	3B	*	G13-1653-04	CUSHION (SP)		C26			CC73GCH1H101J	CHIP C 100PF J	
27	3B	*	G13-1654-04	CUSHION (LED)		C27			C92-0505-05	CHIP-TAN 10UF 16WV	
28	3B	*	G13-1669-04	CUSHION (MIC)		C28-30			CC73GCH1H101J	CHIP C 100PF J	
29	3B	*	G13-1670-04	CUSHION (VOL,TEST)		C31			C92-0505-05	CHIP-TAN 10UF 16WV	
30	3B	*	G13-1703-14	CUSHION (FRONT,PANEL)		C32			CK73GB1H102K	CHIP C 1000PF K	
31		*	H10-6612-02	FOAM PACKING MOLD		C33,34			CC73GCH1H101J	CHIP C 100PF J	
32		*	H20-1437-03	PROTECTION COVER		C35			C92-0505-05	CHIP-TAN 10UF 16WV	
33		*	H52-1109-02	ITEM CARTON CASE		C36			CK73GB1E103K	CHIP C 0.010UF K	
34	1A	*	J21-8375-04	HARDWARE FIXTURE		C37-39			CC73GCH1H101J	CHIP C 100PF J	
36		*	K01-0421-05	HANDLE (ACCESSORY)		C40			CK73EB1C105K	CHIP C 1.0UF K	
37	3A		K29-3002-14	PUSHKNOB (TEST)		C41			CC73GCH1H101J	CHIP C. 100PF J	
38	3B		K29-4539-04	KNOB (VOL)		C42			CC73GCH1H390J	CHIP C 39PF J	
39	2D	*	N09-2292-05	HEXAGON BOSS SCREW		C43			CC73GCH1H101J	CHIP C 100PF J	
A	1B	*	N32-3006-45	FLAT HEAD MACHINE SCREW		C44			CK73FB1E104K	CHIP C 0.10UF K	
B	3A	*	N32-4008-45	FLAT HEAD MACHINE SCREW		C45			CK73GB1H152K	CHIP C 1500PF K	
C	1B		N35-3006-46	BINDING HEAD MACHINE SCREW(WDC)		C46			CK73GB1H272J	CHIP C 2700PF J	
F	1A		N67-2606-46	PAN HEAD SEMS SCREW W		C47			CC73GCH1H101J	CHIP C 100PF J	
G			N67-3006-46	PAN HEAD SEMS SCREW W		C48			CK73GB1H272J	CHIP C 2700PF J	
D	2D		N87-2606-46	BRAZIER HEAD TAPTITE SCREW		C49			CK73GB1H102K	CHIP C 1000PF K	
E	1B	*	N87-2616-46	BRAZIER HEAD TAPTITE SCREW		C50			CK73EB1C105K	CHIP C 1.0UF K	
40	1A		S79-0401-05	THERMAL SWITCH		C51		*	C92-0728-05	ELECTROLYTIC 470UH 16WV	
41	3B		T07-0347-05	SPEAKER		C52			CK73GB1H102K	CHIP C 1000PF K	
<b>CONTROL UNIRT (X53-3810-10)</b>											
D201		*	B30-2197-05	LED (RE,TX)		C53,54		*	C92-0726-05	ELECTROLYTIC 47UH 25WV	
D202,203		*	B30-2198-05	LED (GR,BUSY/POWER)		C55			CK73GB1E103K	CHIP C 0.010UF K	
						C56			CK73FB1E104K	CHIP C 0.10UF K	
						C57,58			CK73GB1H102K	CHIP C 1000PF K	
						C59		*	C92-0726-05	ELECTROLYTIC 47UH 25WV	
						C60		*	C92-0728-05	ELECTROLYTIC 470UH 16WV	
						C61,62			CK73FB1E104K	CHIP C 0.10UF K	
						C63			CK73GB1H102K	CHIP C 1000PF K	

# TKR-830

## PARTS LIST

### CONTROL UNIT (X53-3810-10)

Ref. No.	Address	New parts	Parts No.	Description	Destination	Ref. No.	Address	New parts	Parts No.	Description	Destination
C64			CK73FB1E104K	CHIP C 0 10UF K		C205,206			CC73GCH1H101J	CHIP C 100PF J	
C65,66			CK73GB1E103K	CHIP C 0 010UF K		C207			C92-0505-05	CHIP-TAN 10UF 16WV	
C67			CK73GB1C683K	CHIP C 0 068UF K		C208			CC73GCH1H101J	CHIP C 100PF J	
C68			CK73FB1E104K	CHIP C 0 10UF K		C209			CK73GB1H471K	CHIP C 470PF K	
C69			CK73GB1H222K	CHIP C 2200PF K		C210			CK73GB1H102K	CHIP C 1000PF K	
C70			CC73GCH1H680J	CHIP C 68PF J		C211			CC73GCH1H101J	CHIP C 100PF J	
C71			CK73GB1E103K	CHIP C 0 010UF K		C212			CK73GB1H102K	CHIP C 1000PF K	
C72,73			CC73GCH1H270J	CHIP C 27PF J		C213			CK73GB1H471K	CHIP C 470PF K	
C74,75			CK73GB1H102K	CHIP C 1000PF K		C214			CK73FF1E334Z	CHIP C 0.33UF Z	
C76			CK73GB1H272J	CHIP C 2700PF J		C215			CK73FB1E104K	CHIP C 0 10UF K	
C77			C92-0519-05	CHIP-TAN 1 0UF 25WV		C216,217			CK73GB1H272J	CHIP C 2700PF J	
C78			CC73GCH1H121J	CHIP C 120PF J		C218	*		CK73GB1H562J	CHIP C 5600PF J	
C79-81			C92-0519-05	CHIP-TAN 1 0UF 25WV		C219			CK73EB1C105K	CHIP C 1 0UF K	
C82,83			CK73GB1E104K	CHIP C 1000PF K		C220,221			CK73GB1E103K	CHIP C 0 010UF K	
C84			CK73FB1E104K	CHIP C 0 10UF K		C222			CK73FF1E334Z	CHIP C 0.33UF Z	
C85-89			CK73GB1H102K	CHIP C 1000PF K		C223			CK73FB1E104K	CHIP C 0 10UF K	
C90			CC73GCH1H101J	CHIP C 100PF J		C300-302			CK73GB1E103K	CHIP C 0 010UF K	
C91			CK73GB1H102K	CHIP C 1000PF K		C305			CK73GB1E103K	CHIP C 0.010UF K	
C92,93			CC73GCH1H101J	CHIP C 100PF J		C306			CK73GB1H102K	CHIP C 1000PF K	
C94			CK73GB1E123K	CHIP C 0 012UF K		C307			C92-0505-05	CHIP-TAN 10UF 16WV	
C95			CK73GB1H102K	CHIP C 1000PF K		CN1,2			E40-5736-05	FLAT CABLE CONNECTOR 26P	
C96,97			CC73GCH1H101J	CHIP C 100PF J		CN17			E40-5736-05	FLAT CABLE CONNECTOR 26P	
C98			CK73GB1H102K	CHIP C 1000PF K		CN19	*		E40-5960-05	PIN ASSY 30P	
C99-102			CC73GCH1H101J	CHIP C 100PF J		CN20			E40-5701-05	PIN ASSY 14P	
C103			CK73GB1E103K	CHIP C 0.010UF K		CN200			E40-5761-05	FLAT CABLE CONNECTOR 26P	
C104			CK73GB1H102K	CHIP C 1000PF K		CN201			E40-5821-05	PIN ASSY 6P	
C105			C92-0628-05	CHIP-TAN 10UF 10WV		CN203			E40-5538-05	PIN ASSY	
C106			CK73EB1C105K	CHIP C 1 0UF K		CN205			E40-5701-05	PIN ASSY 14P	
C107			C92-0505-05	CHIP-TAN 10UF 16WV		CN300	*		E40-5986-05	PIN ASSY 6P	
C108,109			CK73EB1C105K	CHIP C 1 0UF K		CN301			E40-5701-05	PIN ASSY 14P	
C110		*	CK73GB1H562J	CHIP C 5600PF J		J201			E08-0876-05	MODULAR JACK	
C111			C92-0628-05	CHIP-TAN 10UF 10WV		L1-3			L40-1015-48	SMALL FIXED INDUCTOR(100UH)	
C112,113		*	CK73GB1H562J	CHIP C 5600PF J		L5-11			L92-0140-05	FERRITE CHIP	
C114,115			C92-0519-05	CHIP-TAN 1 0UF 25WV		L12,13			L92-0131-05	FERRITE CHIP	
C116,117			C92-0628-05	CHIP-TAN 10UF 10WV		X1			L78-0431-05	RESONATOR (14 7456M)	
C118		*	CK73FB1C105K	CHIP C 1 0UF K		CP200-203			R90-1016-05	MULTIPLE R 470	
C119			CK73FB1E104K	CHIP C 0 10UF K		R1			RK73GB1J824J	CHIP R 820K J 1/16W	
C120-125			CK73GB1E103K	CHIP C 0 010UF K		R2			RK73GB1J473J	CHIP R 47K J 1/16W	
C126			CK73FB1E104K	CHIP C 0 10UF K		R3,4			RK73GB1J223J	CHIP R 22K J 1/16W	
C127,128			CK73GB1E103K	CHIP C 0 010UF K		R5			RK73GB1J824J	CHIP R 820K J 1/16W	
C129			C92-0519-05	CHIP-TAN 1 0UF 25WV		R6			RK73GB1J683J	CHIP R 68K J 1/16W	
C130-133			CC73GCH1H101J	CHIP C 100PF J		R7			RK73GB1J223J	CHIP R 22K J 1/16W	
C134			CK73FB1E104K	CHIP C 0 10UF K		R8			RK73GB1J184J	CHIP R 180K J 1/16W	
C135			C92-0501-05	CHIP-TAN 1 5UF 10WV		R9			RK73GB1J183J	CHIP R 18K J 1/16W	
C136			CK73FB1E104K	CHIP C 0 10UF K		R10			RK73GB1J103J	CHIP R 10K J 1/16W	
C137			CC73GCH1H470J	CHIP C 47PF J		R11			RK73GB1J474J	CHIP R 470K J 1/16W	
C138			CK73FB1H333K	CHIP C 0 033UF K		R12			RK73GB1J684J	CHIP R 680K J 1/16W	
C139			CC73GCH1H101J	CHIP C 100PF J		R13			RK73GB1J184J	CHIP R 180K J 1/16W	
C140			CC73GCH1H330J	CHIP C 33PF J		R14			RK73GB1J223J	CHIP R 22K J 1/16W	
C141			CK73GB1H561J	CHIP C 560PF J		R15			RK73GB1J824J	CHIP R 820K J 1/16W	
C142			CK73GB1H331K	CHIP C 330PF K		R16			RK73GB1J474J	CHIP R 470K J 1/16W	
C143		*	CK73GB1H152J	CHIP C 1500PF J		R17			RK73GB1J224J	CHIP R 220K J 1/16W	
C144			CC73GCH1H390J	CHIP C 39PF J		R18			RK73GB1J561J	CHIP R 560 J 1/16W	
C145			CK73EB1C105K	CHIP C 1 0UF K		R19			RK73GB1J473J	CHIP R 47K J 1/16W	
C146			CK73GB1H272J	CHIP C 2700PF J		R20,21			RK73GB1J184J	CHIP R 180K J 1/16W	
C148			CK73GB1H182K	CHIP C 1800PF K		R22			RK73GB1J224J	CHIP R 220K J 1/16W	
C155		*	C92-0729-05	ELECTROLYTIC 330UH 25WV		R23			RK73GB1J105J	CHIP R 1 0M J 1/16W	
C201			CK73FB1E104K	CHIP C 0 10UF K							
C202,203			CC73GCH1H101J	CHIP C 100PF J							
C204			CK73FF1E334Z	CHIP C 0.33UF Z							



## PARTS LIST

CONTROL UNIT (X53-3810-10)

Ref. No.	Address	New parts	Parts No.	Description	Destination	Ref. No.	Address	New parts	Parts No.	Description	Destination
R24			RK73GB1J104J	CHIP R 100K J 1/16W		R111			RK73GB1J473J	CHIP R 47K J 1/16W	
R25			RK73GB1J473J	CHIP R 47K J 1/16W		R112,113			RK73GB1J102J	CHIP R 1 0K J 1/16W	
R26			RK73GB1J154J	CHIP R 150K J 1/16W		R115-117			RK73GB1J102J	CHIP R 1 0K J 1/16W	
R27			RK73GB1J103J	CHIP R 10K J 1/16W		R118-120			RK73GB1J473J	CHIP R 47K J 1/16W	
R28			RK73GB1J104J	CHIP R 100K J 1/16W		R121			RK73GB1J563J	CHIP R 56K J 1/16W	
R29			RK73GB1J272J	CHIP R 2.7K J 1/16W		R122			RK73GB1J473J	CHIP R 47K J 1/16W	
R30,31			RK73GB1J334J	CHIP R 330K J 1/16W		R124			RK73GB1J274G	CHIP R 270K G 1/16W	
R32-39			RK73GB1J102J	CHIP R 1.0K J 1/16W		R125			RK73GB1J394J	CHIP R 390K J 1/16W	
R40			RK73GB1J274J	CHIP R 270K J 1/16W		R126			RK73GB1J473G	CHIP R 47K G 1/16W	
R41			RK73GB1J224J	CHIP R 220K J 1/16W		R127			RK73GB1J563G	CHIP R 56K G 1/16W	
R42			R92-0685-05	CHIP R 22 J 1/2W		R129			RK73GB1J103J	CHIP R 10K J 1/16W	
R43			RK73GB1J272J	CHIP R 2.7K J 1/16W		R130			RK73GB1J123J	CHIP R 12K J 1/16W	
R44			RK73GB1J224J	CHIP R 220K J 1/16W		R131			RK73GB1J104J	CHIP R 100K J 1/16W	
R45			RK73GB1J274J	CHIP R 270K J 1/16W		R132			RK73GB1J124J	CHIP R 120K J 1/16W	
R46			RK73GB1J332J	CHIP R 3.3K J 1/16W		R133			RK73GB1J103J	CHIP R 10K J 1/16W	
R47			RK73GB1J274J	CHIP R 270K J 1/16W		R134			RK73GB1J563J	CHIP R 56K J 1/16W	
R48			RK73GB1J473J	CHIP R 47K J 1/16W		R137			RK73GB1J473J	CHIP R 47K J 1/16W	
R49,50			RK73GB1J102J	CHIP R 1 0K J 1/16W		R138			RK73GB1J104J	CHIP R 100K J 1/16W	
R51,52			RK73GB1J274J	CHIP R 270K J 1/16W		R139			RK73GB1J124J	CHIP R 120K J 1/16W	
R53			RK73GB1J393J	CHIP R 39K J 1/16W		R140,141			RK73GB1J104J	CHIP R 100K J 1/16W	
R54			RK73GB1J334J	CHIP R 330K J 1/16W		R142			RK73GB1J223J	CHIP R 22K J 1/16W	
R55			RK73GB1J474J	CHIP R 470K J 1/16W		R143			RK73GB1J224J	CHIP R 220K J 1/16W	
R56			RK73GB1J823J	CHIP R 82K J 1/16W		R146			RK73GB1J102J	CHIP R 1 0K J 1/16W	
R57,58			RK73GB1J332J	CHIP R 3.3K J 1/16W		R147			RK73GB1J471J	CHIP R 470 J 1/16W	
R59			RK73GB1J394J	CHIP R 390K J 1/16W		R149,150			RK73GB1J102J	CHIP R 1 0K J 1/16W	
R60			RK73GB1J223J	CHIP R 22K J 1/16W		R151			RK73GB1J471J	CHIP R 470 J 1/16W	
R61			RK73GB1J154J	CHIP R 150K J 1/16W		R152			RK73GB1J102J	CHIP R 1 0K J 1/16W	
R62			RK73GB1J471J	CHIP R 470 J 1/16W		R153			RK73GB1J471J	CHIP R 470 J 1/16W	
R63			RK73GB1J154J	CHIP R 150K J 1/16W		R155-167			RK73GB1J102J	CHIP R 1 0K J 1/16W	
R64			RK73GB1J105J	CHIP R 1 0M J 1/16W		R169			RK73GB1J102J	CHIP R 1.0K J 1/16W	
R65			RK73GB1J103J	CHIP R 10K J 1/16W		R171-175			RK73GB1J102J	CHIP R 1 0K J 1/16W	
R66			RK73FB2A2R2J	CHIP R 2 2 J 1/10W		R179,180			RK73GB1J471J	CHIP R 470 J 1/16W	
R67			RK73GB1J103J	CHIP R 10K J 1/16W		R181-184			RK73GB1J102J	CHIP R 1 0K J 1/16W	
R68			RK73GB1J472J	CHIP R 4.7K J 1/16W		R185			RK73GB1J471J	CHIP R 470 J 1/16W	
R69			RK73GB1J473J	CHIP R 47K J 1/16W		R186-189			RK73GB1J102J	CHIP R 1 0K J 1/16W	
R70			RK73GB1J102J	CHIP R 1 0K J 1/16W		R200			RK73FB2A331J	CHIP R 330 J 1/10W	
R71-75			RK73GB1J473J	CHIP R 47K J 1/16W		R201,202			RK73FB2A221J	CHIP R 220 J 1/10W	
R76-79			RK73GB1J102J	CHIP R 1 0K J 1/16W		R203			R92-1252-05	CHIP R 0 OHM	
R80			RK73GB1J222J	CHIP R 2 2K J 1/16W		R204			RK73GB1J102J	CHIP R 1 0K J 1/16W	
R81			RK73GB1J564J	CHIP R 560K J 1/16W		R205			RK73GB1J681J	CHIP R 680 J 1/16W	
R82			RK73GB1J224J	CHIP R 220K J 1/16W		R206			RK73GB1J102J	CHIP R 1 0K J 1/16W	
R83-86			RK73GB1J103J	CHIP R 10K J 1/16W		R207			R92-1279-05	CHIP R 33 J 1W	
R87			RK73GB1J473J	CHIP R 47K J 1/16W		R208,209			RK73GB1J102J	CHIP R 1 0K J 1/16W	
R88			RK73GB1J122J	CHIP R 1 2K J 1/16W		R210			RK73GB1J683J	CHIP R 68K J 1/16W	
R89			R92-0670-05	CHIP R 0 OHM		R211,212			RK73GB1J274G	CHIP R 270K G 1/16W	
R90			RK73GB1J472J	CHIP R 4 7K J 1/16W		R213			RK73GB1J184J	CHIP R 180K J 1/16W	
R91			RK73GB1J103J	CHIP R 10K J 1/16W		R214			RK73FB2A221J	CHIP R 220 J 1/10W	
R92,93			RK73GB1J122J	CHIP R 1.2K J 1/16W		R215			RK73FB2A331J	CHIP R 330 J 1/10W	
R94			R92-1252-05	CHIP R 0 OHM		R216			RK73FB2A472J	CHIP R 4 7K J 1/10W	
R95			RK73GB1J122J	CHIP R 1 2K J 1/16W		R235-237			R92-1213-05	CHIP R 100 J 1/2W	
R96			RK73GB1J102J	CHIP R 1 0K J 1/16W		R300			RK73GB1J101J	CHIP R 100 J 1/16W	
R97,98			RK73GB1J474J	CHIP R 470K J 1/16W		R301			R92-1252-05	CHIP R 0 OHM	
R99,100			RK73GB1J224J	CHIP R 220K J 1/16W		R302			RK73GB1J101J	CHIP R 100 J 1/16W	
R101			RK73GB1J102J	CHIP R 1 0K J 1/16W		R303,304			RK73GB1J102J	CHIP R 1 0K J 1/16W	
R102,103			RK73GB1J473J	CHIP R 47K J 1/16W		R305,306			RK73GB1J473J	CHIP R 47K J 1/16W	
R104			RK73GB1J224J	CHIP R 220K J 1/16W		R307-312			RK73GB1J102J	CHIP R 1 0K J 1/16W	
R105			RK73GB1J473J	CHIP R 47K J 1/16W		R313-318			RK73GB1J473J	CHIP R 47K J 1/16W	
R106			RK73GB1J224J	CHIP R 220K J 1/16W		R319			RK73GB1J102J	CHIP R 1 0K J 1/16W	
R107-109			RK73GB1J473J	CHIP R 47K J 1/16W		R323			RK73GB1J473J	CHIP R 47K J 1/16W	
R110			RK73GB1J102J	CHIP R 1 0K J 1/16W		R324			RK73GB1J102J	CHIP R 1 0K J 1/16W	

## PARTS LIST

### CONTROL UNIT (X53-3810-10)

Ref. No.	Address	New parts	Parts No.	Description	Destination
R325			RK73GB1J103J	CHIP R 10K J 1/16W	
R326			RK73GB1J473J	CHIP R 47K J 1/16W	
R327			RK73GB1J474J	CHIP R 470K J 1/16W	
R328			RK73GB1J2R2J	CHIP R 2 2 J 1/16W	
R331			RK73GB1J103J	CHIP R 10K J 1/16W	
VR201			R12-6423-05	TRIMMING POT.(10K)	
VR301			R05-3442-05	POTENTIOMETER(10K)	
S1,2			S79-0421-05	DIP SWITCHES	
S200			S40-2441-15	PUSH SWITCH	
D1			HSM88AS	DIODE	
D6-9			DA204U	DIODE	
D11			DA204U	DIODE	
D13			DA204U	DIODE	
D15			DA204U	DIODE	
D16			1SS355	DIODE	
D17,18			DA204U	DIODE	
D20-32			DA204U	DIODE	
D200		*	MINISMDCC075-02	VARISTOR	
D207-209			DA204U	DIODE	
D214			DA204U	DIODE	
IC1			NJM78L08UA	IC (VOLTAGE REGULATOR/ +8V)	
IC2-5			NJM4558E	IC (OP AMP X2)	
IC6			NJM78L05UA	IC (VOLTAGE REGULATOR/ +5V)	
IC7			BU4053BCF	IC (AUDIO SWS SW)	
IC8			LA4422	IC (POWER AMP)	
IC9			BU4094BCFV	IC (8bit SHIFT/STORE REGISTER)	
IC10		*	MC-8800-804	IC (MICROPROCESSOR)	
IC11			NJM4558E	IC (OP AMP X2)	
IC12			RH5V142C	IC (REGULATOR)	
IC13			NJM4558E	IC (OP AMP X2)	
IC14			ADM232LAR	IC (RS-232C DRIVERS/RECEIVERS)	
IC15			NJM4558E	IC (OP AMP X2)	
IC101			TC7S08FU	IC (2INPUT AND GATE)	
IC102			TC7S32FU	IC (2INPUT OR GATE)	
IC103			TC7S02FU	IC (2,INPUT NOR GATE)	
IC104			M62364FP	IC (D/A CONVERTER)	
IC105,106			NJM4558E	IC (OP AMP X2)	
IC107,108			BU4053BCF	IC (ANALOG SW)	
IC109			TC7S00FU	IC (NAND GATE)	
IC200-202			NJM78L05UA	IC (VOLTAGE REGULATOR/ +5V)	
IC204-206			BU2114F	IC (LED DRIVER)	
Q1		*	DTC144EUA	DIGITAL TRANSISTOR	
Q2			DTC363EK	DIGITAL TRANSISTOR	
Q3			2SC4081(R)	TRANSISTOR	
Q4			2SC2712(Y)	TRANSISTOR	
Q5		*	DTC144EUA	DIGITAL TRANSISTOR	
Q6			DTC114EUA	DIGITAL TRANSISTOR	
Q7			2SD1757K	TRANSISTOR	
Q8			DTC114EUA	DIGITAL TRANSISTOR	
Q9			2SC4215(Y)	TRANSISTOR	
Q10			DTA144EUA	DIGITAL TRANSISTOR	
Q200,201		*	DTC144EUA	DIGITAL TRANSISTOR	
Q202			DTA114EUA	DIGITAL TRANSISTOR	
Q203		*	DTC144EUA	DIGITAL TRANSISTOR	
Q204			DTA114EUA	DIGITAL TRANSISTOR	
Q211		*	DTC144EUA	DIGITAL TRANSISTOR	
TH1			157-302-65801	THERMISTOR	

Ref. No.	Address	New parts	Parts No.	Description	Destination
<b>RX UNIT (X55-3040-10)</b>					
C1			CC73GCH1H030C	CHIP C 3.0PF C	
C2			CK73GB1H102K	CHIP C 1000PF K	
C3			CK73GB1H471K	CHIP C 470PF K	
C4			CK73GB1H102K	CHIP C 1000PF K	
C5			CK73GB1H103K	CHIP C 0.010UF K	
C6			CK73GB1H102K	CHIP C 1000PF K	
C7			CK73GB1H471K	CHIP C 470PF K	
C8			C92-0002-05	CHIP-TAN 0.22UF 35WV	
C9			C92-0633-05	CHIP-TAN 22UF 10WV	
C10		*	C92-0545-05	CHIP-TAN 2.2UF 6 3WV	
C11			CK73GB1H471K	CHIP C 470PF K	
C12			CC73GCH1H070D	CHIP C 7.0PF D	
C13			CC73GCH1H2R5C	CHIP C 2.5PF C	
C14			C92-0001-05	CHIP-C 0.1UF 35WV	
C15			CC73FCH1H060D	CHIP C 6.0PF D	
C16			CC73GCH1H080D	CHIP C 8.0PF D	
C17			CC73FCH1H120J	CHIP C 12PF J	
C18			CK73GB1H103K	CHIP C 0.010UF K	
C19,20			CK73GB1H471K	CHIP C 470PF K	
C21			CC73FCH1H050C	CHIP C 5 0PF C	
C22			CK73GB1H102K	CHIP C 1000PF K	
C23			CC73GCH1H020C	CHIP C 2.0PF C	
C24			CC73GCH1H101J	CHIP C 100PF J	
C25			CC73FCH1H100D	CHIP C 10PF D	
C26			CK73GB1H471K	CHIP C 470PF K	
C27			CK73GB1H102K	CHIP C 1000PF K	
C28			CK73FB1E104K	CHIP C 0.10UF K	
C30,31			CK73GB1H471K	CHIP C 470PF K	
C32			CC73FCH1H080D	CHIP C 8.0PF D	
C33			CC73GCH1H220J	CHIP C 22PF J	
C34,35			CK73GB1H102K	CHIP C 1000PF K	
C36			CK73GB1H471K	CHIP C 470PF K	
C38			CC73GCH1H101J	CHIP C 100PF J	
C39			CC73GCH1H150J	CHIP C 15PF J	
C40			CC73FCH1H080D	CHIP C 8.0PF D	
C41			CK73GB1H102K	CHIP C 1000PF K	
C42			CK73FB1E104K	CHIP C 0.10UF K	
C43			CC73FCH1H100D	CHIP C 10PF D	
C44			CC73FCH1H070D	CHIP C 7 0PF D	
C45,46			CK73GB1H102K	CHIP C 1000PF K	
C47			CC73FCH1H070D	CHIP C 7.0PF D	
C48			C92-0628-05	CHIP-TAN 10UF 10WV	
C49			CC73GCH1H0R5C	CHIP C 0.5PF C	
C50			CC73FCH1H100D	CHIP C 10PF D	
C51,52			CK73GB1H102K	CHIP C 1000PF K	
C53			C92-0628-05	CHIP-TAN 10UF 10WV	
C54			CK73GB1H102K	CHIP C 1000PF K	
C55			CK73GB1H103K	CHIP C 0 010UF K	
C57			CC73GCH1H0R5C	CHIP C 0 5PF C	
C58			CK73GB1H102K	CHIP C 1000PF K	
C60,61			CK73FB1E104K	CHIP C 0 10UF K	
C62			CK73GB1H102K	CHIP C 1000PF K	
C63			CK73GB1H103K	CHIP C 0.010UF K	
C64			CK73GB1H102K	CHIP C 1000PF K	
C65			CC73GCH1H100D	CHIP C 10PF D	
C66			CK73GB1H471K	CHIP C 470PF K	
C67			CC73GCH1H150J	CHIP C 15PF J	
C68			CC73GCH1H080D	CHIP C 8 0PF D	
C69			CK73GB1H471K	CHIP C 470PF K	

## PARTS LIST

RX UNIT (X55-3040-10)

Ref. No.	Address	New parts	Parts No.	Description	Destination	Ref. No.	Address	New parts	Parts No.	Description	Destination
C70			C92-0555-05	CHIP-TAN 0.047UF 35WV		C143,144			CK73GB1H103K	CHIP C 0.010UF K	
C71			CC73GCH1H150J	CHIP C 15PF J		C145			CK73GB1E223K	CHIP C 0.022UF K	
C72,73			CK73GB1H102K	CHIP C 1000PF K		C146-148			CK73GB1H103K	CHIP C 0.010UF K	
C74			CK73GB1H471K	CHIP C 470PF K		C149			CK73FB1E104K	CHIP C 0.10UF K	
C75			CC73GCH1H150J	CHIP C 15PF J		C150			C92-0628-05	CHIP-TAN 10UF 10WV	
C76			C92-0001-05	CHIP-C 0.1UF 35WV		C151,152			CK73GB1H103K	CHIP C 0.010UF K	
C77			CK73FB1E104K	CHIP C 0.10UF K		C153			CK73GB1H102K	CHIP C 1000PF K	
C78			CC73GCH1H040C	CHIP C 4.0PF C		C154,155			CK73GB1H103K	CHIP C 0.010UF K	
C79			CC73GCH1H080D	CHIP C 8.0PF D		C156			CC73GCH1H040C	CHIP C 4.0PF C	
C80			CK73GB1H102K	CHIP C 1000PF K		C157			CK73GB1H102K	CHIP C 1000PF K	
C81			CC73GCH1H020C	CHIP C 2.0PF C		C158,159			CK73GB1H103K	CHIP C 0.010UF K	
C82	*		C92-0728-05	ELECTROLYTIC 470UH 16WV		C160,161			CK73GB1H102K	CHIP C 1000PF K	
C83-85			CK73GB1H103K	CHIP C 0.010UF K		C162,163			CK73GB1H103K	CHIP C 0.010UF K	
C86			CC73GCH1H470J	CHIP C 47PF J		C164			CK73GB1H102K	CHIP C 1000PF K	
C87			CK73GB1H102K	CHIP C 1000PF K		C165			C92-0003-05	CHIP-TAN 0.47UF 25WV	
C88			C92-0633-05	CHIP-TAN 22UF 10WV		C166			CC73GCH1H080D	CHIP C 8.0PF D	
C89-91			CK73GB1H103K	CHIP C 0.010UF K		C167			CK73FB1E104K	CHIP C 0.10UF K	
C92			CC73GCH1H040C	CHIP C 4.0PF C		C168			CK73GB1H103K	CHIP C 0.010UF K	
C93			CC73GCH1H120J	CHIP C 12PF J		C169,170			C92-0628-05	CHIP-TAN 10UF 10WV	
C94			CC73GCH1H050C	CHIP C 5.0PF C		C171			C92-0003-05	CHIP-TAN 0.47UF 25WV	
C95			CC73GCH1H040C	CHIP C 4.0PF C		C172,173			CK73FB1E104K	CHIP C 0.10UF K	
C96,97			CK73GB1H103K	CHIP C 0.010UF K		C174,175			CK73GB1H102K	CHIP C 1000PF K	
C98			CC73GCH1H220J	CHIP C 22PF J		C176,177			CK73FB1E104K	CHIP C 0.10UF K	
C99			CK73GB1H103K	CHIP C 0.010UF K		C178,179			CK73GB1H221K	CHIP C 220PF K	
C100			CC73GCH1H050C	CHIP C 5.0PF C		C180			CK73FB1E104K	CHIP C 0.10UF K	
C101			CK73FB1E223K	CHIP C 0.022UF K		C181,182			CK73GB1H221K	CHIP C 220PF K	
C102			CC73GCH1H020C	CHIP C 2.0PF C		C183-186			CK73FB1E104K	CHIP C 0.10UF K	
C103,104			CK73GB1H103K	CHIP C 0.010UF K		C187,188			CK73GB1H102K	CHIP C 1000PF K	
C105,106			C92-0589-05	CHIP-TAN 47UF 6.3WV		C189,190			CC73GCH1H270J	CHIP C 27PF J	
C107			CK73GB1H471K	CHIP C 470PF K		C191,192			CK73FB1E104K	CHIP C 0.10UF K	
C108-110			CK73GB1H103K	CHIP C 0.010UF K		C193			CC73GCH1H680J	CHIP C 68PF J	
C111			CC73GCH1H220J	CHIP C 22PF J		C194			CC73GCH1H220J	CHIP C 22PF J	
C112,113			CK73GB1H103K	CHIP C 0.010UF K		C195			CK73GB1H102K	CHIP C 1000PF K	
C114			CK73GB1H102K	CHIP C 1000PF K		C196			C92-0628-05	CHIP-TAN 10UF 10WV	
C115			CK73FB1E104K	CHIP C 0.10UF K		C197			CK73GB1H102K	CHIP C 1000PF K	
C116			CK73GB1H103K	CHIP C 0.010UF K		C198-200			C92-0628-05	CHIP-TAN 10UF 10WV	
C117			CK73GB1H102K	CHIP C 1000PF K		C201,202			CK73FB1E104K	CHIP C 0.10UF K	
C118-120			CK73GB1H103K	CHIP C 0.010UF K		C203-205			C92-0628-05	CHIP-TAN 10UF 10WV	
C121			CC73GCH1H040C	CHIP C 4.0PF C		C206			CC73GCH1H470J	CHIP C 47PF J	
C122			CK73FB1E104K	CHIP C 0.10UF K		C207			CK73GB1H471K	CHIP C 470PF K	
C123			CK73GB1H562K	CHIP C 5600PF K		C208			CK73FB1E104K	CHIP C 0.10UF K	
C124			C92-0633-05	CHIP-TAN 22UF 10WV		C209			CK73GB1H103K	CHIP C 0.010UF K	
C125			CC73GCH1H050C	CHIP C 5.0PF C		C210			C92-0633-05	CHIP-TAN 22UF 10WV	
C126			CK73FB1E104K	CHIP C 0.10UF K		C211			CC73GCH1H080D	CHIP C 8.0PF D	
C127			CK73GB1H562K	CHIP C 5600PF K		C212			CK73GB1H103K	CHIP C 0.010UF K	
C128			CC73GCH1H040C	CHIP C 4.0PF C		C213			CK73FB1E104K	CHIP C 0.10UF K	
C129			CK73GB1C393K	CHIP C 0.039UF K		C214			CK73GB1H102K	CHIP C 1000PF K	
C130			CC73GCH1H050C	CHIP C 5.0PF C		C215,216			CC73GCH1H270J	CHIP C 27PF J	
C131			CK73GB1H103K	CHIP C 0.010UF K		C217			CK73GB1H471K	CHIP C 470PF K	
C132			CC73GCH1H040C	CHIP C 4.0PF C		C218,219			CC73GCH1H220J	CHIP C 22PF J	
C133			CK73GB1H103K	CHIP C 0.010UF K		C220			CC73GCH1H070D	CHIP C 7PF D	
C134			C92-0633-05	CHIP-TAN 22UF 10WV		TC1,2			C05-0393-05	CERAMIC TRIMMER CAP(8P)	
C135			CK73GB1H103K	CHIP C 0.010UF K		CN1	*		E04-0409-05	RF COAXIAL RECEPTACLE(SMB)	
C136			CC73GCH1H040C	CHIP C 4.0PF C		CN2			E04-0154-05	PIN SOCKET	
C137			CK73GB1H103K	CHIP C 0.010UF K		CN3-5			E40-5538-05	PIN ASSY	
C138			CK73GB1C333K	CHIP C 0.033UF K		CN6			E40-5736-05	FLAT CABLE CONNECTOR	
C139			CC73GCH1H040C	CHIP C 4.0PF C		CN7	*		E04-0409-05	RF COAXIAL RECEPTACLE(SMB)	
C140			C92-0001-05	CHIP-C 0.1UF 35WV		CF1	*		L72-0956-05	CERAMIC FILTER CFWC450F	
C141			CC73GCH1H050C	CHIP C 5.0PF C							
C142			CK73FB1E104K	CHIP C 0.10UF K							

## PARTS LIST

RX UNIT (X55-3040-10)

Ref. No.	Address	New parts	Parts No.	Description	Destination	Ref. No.	Address	New parts	Parts No.	Description	Destination
CF2		*	L72-0953-05	CERAMIC FILTER CFWC450D		R1			RK73GB1J105J	CHIP R	1.0M J 1/16W
CF3		*	L72-0956-05	CERAMIC FILTER CFWC450F		R2			RK73GB1J183J	CHIP R	18K J 1/16W
CF4		*	L72-0953-05	CERAMIC FILTER CFWC450D		R3,4			RK73GB1J473J	CHIP R	47K J 1/16W
L1		*	L34-4523-05	AIR-CORE COIL		R5			R92-1252-05	CHIP R	0 OHM
L2		*	L40-1098-76	SMALL FIXED INDUCTOR(1UH)		R6			RK73GB1J223J	CHIP R	22K J 1/16W
L3		*	L79-1529-05	HELICAL BLOCK 450-480MHZ		R7			RK73GB1J470J	CHIP R	47 J 1/16W
L4		*	L40-1098-76	SMALL FIXED INDUCTOR(1UH)		R8			R92-1252-05	CHIP R	0 OHM
L5		*	L40-1875-34	SMALL FIXED INDUCTOR(18NH)		R9			RK73GB1J560J	CHIP R	56 J 1/16W
L6,7		*	L40-1098-76	SMALL FIXED INDUCTOR(1UH)		R10			RK73GB1J222J	CHIP R	2.2K J 1/16W
L8		*	L34-4524-05	AIR-CORE COIL		R11			RK73GB1J102J	CHIP R	1.0K J 1/16W
L9		*	L40-1098-76	SMALL FIXED INDUCTOR(1UH)		R12			RK73GB1J222J	CHIP R	2.2K J 1/16W
L10		*	L34-4524-05	AIR-CORE COIL		R16,17			RK73GB1J222J	CHIP R	2.2K J 1/16W
L11		*	L40-1098-76	SMALL FIXED INDUCTOR(1UH)		R18,19			RK73GB1J103J	CHIP R	10K J 1/16W
L12		*	L40-1575-34	SMALL FIXED INDUCTOR(15NH)		R20			RK73FB2A100J	CHIP R	10 J 1/10W
L13		*	L40-1875-34	SMALL FIXED INDUCTOR(18NH)		R21			RK73GB1J272J	CHIP R	2.7K J 1/16W
L14,15		*	L40-1098-76	SMALL FIXED INDUCTOR(1UH)		R22			RK73GB1J102J	CHIP R	1.0K J 1/16W
L16		*	L79-1529-05	HELICAL BLOCK 450-480MHZ		R23			R92-0670-05	CHIP R	0 OHM
L17		*	L40-1098-76	SMALL FIXED INDUCTOR(1UH)		R24			R92-1252-05	CHIP R	0 OHM
L18		*	L40-1005-34	SMALL FIXED INDUCTOR(10UH)		R25			RK73FB2A100J	CHIP R	10 J 1/10W
L19		*	L40-1575-34	SMALL FIXED INDUCTOR(15NH)		R26			RK73GB1J101J	CHIP R	100 J 1/16W
L20		*	L40-1005-34	SMALL FIXED INDUCTOR(10UH)		R27			R92-0670-05	CHIP R	0 OHM
L21,22		*	L40-1875-34	SMALL FIXED INDUCTOR(18NH)		R29			RK73GB1J823J	CHIP R	82K J 1/16W
L23		*	L40-1575-34	SMALL FIXED INDUCTOR(15NH)		R30			RK73GB1J101J	CHIP R	100 J 1/16W
L24		*	L40-1005-34	SMALL FIXED INDUCTOR(10UH)		R31			RK73GB1J470J	CHIP R	47 J 1/16W
L25		*	L40-1085-34	SMALL FIXED INDUCTOR(100NH)		R32			RK73GB1J101J	CHIP R	100 J 1/16W
L26		*	L40-1295-34	SMALL FIXED INDUCTOR(1.2UH)		R33			R92-1252-05	CHIP R	0 OHM
L27		*	L34-4528-05	COIL		R35			RK73GB1J470J	CHIP R	47 J 1/16W
L28		*	L34-4529-05	COIL		R36			R92-1252-05	CHIP R	0 OHM
L29		*	L40-1005-34	SMALL FIXED INDUCTOR(10UH)		R37,38			R92-0670-05	CHIP R	0 OHM
L30		*	L40-3385-34	SMALL FIXED INDUCTOR(330NH)		R39			RK73GB1J101J	CHIP R	100 J 1/16W
L31		*	L34-4528-05	COIL		R40			R92-1252-05	CHIP R	0 OHM
L32		*	L34-4529-05	COIL		R41			RK73GB1J271J	CHIP R	270 J 1/16W
L33		*	L40-2285-34	SMALL FIXED INDUCTOR(220NH)		R42,43			R92-1252-05	CHIP R	0 OHM
L34,35		*	L40-1085-34	SMALL FIXED INDUCTOR(100NH)		R44			RK73GB1J470J	CHIP R	47 J 1/16W
L36,37		*	L40-1005-34	SMALL FIXED INDUCTOR(10UH)		R45			RK73GB1J103J	CHIP R	10K J 1/16W
L38		*	L34-4528-05	COIL		R46			RK73GB1J472J	CHIP R	4.7K J 1/16W
L39		*	L34-4529-05	COIL		R48			RK73GB1J470J	CHIP R	47 J 1/16W
L40		*	L34-4528-05	COIL		R49			RK73GB1J271J	CHIP R	270 J 1/16W
L41		*	L34-4529-05	COIL		R50,51			RK73GB1J222J	CHIP R	2.2K J 1/16W
L42		*	L40-1005-34	SMALL FIXED INDUCTOR(10UH)		R53,54			RK73GB1J103J	CHIP R	10K J 1/16W
L43		*	L34-4528-05	COIL		R55			RK73GB1J222J	CHIP R	2.2K J 1/16W
L44		*	L34-4529-05	COIL		R56			RK73GB1J223J	CHIP R	22K J 1/16W
L45		*	L40-1085-34	SMALL FIXED INDUCTOR(100NH)		R57			RK73GB1J101J	CHIP R	100 J 1/16W
L46		*	L40-1005-34	SMALL FIXED INDUCTOR(10UH)		R58			RK73GB1J472J	CHIP R	4.7K J 1/16W
L47		*	L40-1085-34	SMALL FIXED INDUCTOR(100NH)		R59,60			RK73GB1J221J	CHIP R	220 J 1/16W
L48		*	L40-1005-34	SMALL FIXED INDUCTOR(10UH)		R61			RK73GB1J472J	CHIP R	4.7K J 1/16W
L49,50		*	L40-1875-34	SMALL FIXED INDUCTOR(18NH)		R62			R92-1252-05	CHIP R	0 OHM
L51		*	L40-3985-34	SMALL FIXED INDUCTOR(390NH)		R63			RK73GB1J184J	CHIP R	180K J 1/16W
L52,53		*	L34-4530-05	COIL 455KHZ		R64			RK73GB1J101J	CHIP R	100 J 1/16W
L54		*	L40-3985-34	SMALL FIXED INDUCTOR(390NH)		R65			RK73GB1J102J	CHIP R	1.0K J 1/16W
L55		*	L40-6875-34	SMALL FIXED INDUCTOR(68NH)		R66			RK73GB1J103J	CHIP R	10K J 1/16W
L56		*	L40-1075-34	SMALL FIXED INDUCTOR(10NH)		R67,68			RK73GB1J821J	CHIP R	820 J 1/16W
L57		*	L92-0131-05	FERRITE CHIP		R69,70			RK73GB1J103J	CHIP R	10K J 1/16W
L58		*	L40-1575-34	SMALL FIXED INDUCTOR(15NH)		R71			RK73FB2A150J	CHIP R	15 J 1/10W
X1		*	L77-1753-05	CRYSTAL RESONATOR(72.6MHZ)		R72			RK73GB1J100J	CHIP R	10 J 1/16W
XF1		*	L71-0510-05	MCF (7.5K)		R73,74			RK73GB1J331J	CHIP R	330 J 1/16W
XF2		*	L71-0511-05	MCF (3.75K)		R75			R92-1252-05	CHIP R	0 OHM
XF3		*	L71-0527-05	MCF (73.05MHZ 8.5K)		R76			RK73GB1J182J	CHIP R	1.8K J 1/16W
XF4		*	L71-0528-05	MCF (73.05MHZ 4.25K)		R77			RK73GB1J470J	CHIP R	47 J 1/16W
		*				R78			RK73GB1J103J	CHIP R	10K J 1/16W

## PARTS LIST

RX UNIT (X55-3040-10)

Ref. No.	Address	New parts	Parts No.	Description	Destination	Ref. No.	Address	New parts	Parts No.	Description	Destination
R79			RK73GB1J102J	CHIP R 10K J 1/16W		R140			RK73GB1J103J	CHIP R 10K J 1/16W	
R80			RK73GB1J122J	CHIP R 12K J 1/16W		R141			RK73GB1J221J	CHIP R 220 J 1/16W	
R81			RK73GB1J103J	CHIP R 10K J 1/16W		R142			RK73GB1J100J	CHIP R 10 J 1/16W	
R82			RK73FB2A220J	CHIP R 22 J 1/10W		R143			RK73GB1J680J	CHIP R 68 J 1/16W	
R83			R92-1252-05	CHIP R 0 OHM		R144,145			RK73GB1J101J	CHIP R 100 J 1/16W	
R84			RK73GB1J103J	CHIP R 10K J 1/16W		R146			RK73GB1J221J	CHIP R 220 J 1/16W	
R85			RK73GB1J182J	CHIP R 1.8K J 1/16W		R147,148			RK73GB1J560J	CHIP R 56 J 1/16W	
R86			RK73GB1J391J	CHIP R 390 J 1/16W		R149,150			RK73GB1J154J	CHIP R 150K J 1/16W	
R87			RK73GB1J101J	CHIP R 100 J 1/16W		R151			RK73GB1J222J	CHIP R 22K J 1/16W	
R88			RK73GB1J223J	CHIP R 22K J 1/16W		R152,153			RK73GB1J103J	CHIP R 10K J 1/16W	
R89			RK73GB1J103J	CHIP R 10K J 1/16W		R154,155			RK73GB1J223J	CHIP R 22K J 1/16W	
R90			RK73GB1J681J	CHIP R 680 J 1/16W		R156,157			RK73GB1J332J	CHIP R 3.3K J 1/16W	
R91			RK73GB1J101J	CHIP R 100 J 1/16W		R158			RK73GB1J222J	CHIP R 22K J 1/16W	
R92			RK73GB1J681J	CHIP R 680 J 1/16W		R159			RK73GB1J272J	CHIP R 27K J 1/16W	
R93			RK73GB1J680J	CHIP R 68 J 1/16W		R160			RK73GB1J222J	CHIP R 22K J 1/16W	
R94			RK73GB1J101J	CHIP R 100 J 1/16W		R161			RK73GB1J272J	CHIP R 27K J 1/16W	
R95			RK73GB1J152J	CHIP R 1.5K J 1/16W		R162			RK73GB1J153J	CHIP R 15K J 1/16W	
R96			RK73GB1J470J	CHIP R 47 J 1/16W		R163			RK73GB1J123J	CHIP R 12K J 1/16W	
R97			RK73FB2A220J	CHIP R 22 J 1/10W		R164,165			RK73GB1J473J	CHIP R 47K J 1/16W	
R98			RK73GB1J680J	CHIP R 68 J 1/16W		R166			RK73GB1J474J	CHIP R 470K J 1/16W	
R99			RK73GB1J152J	CHIP R 1.5K J 1/16W		R167			RK73GB1J224J	CHIP R 220K J 1/16W	
R100			RK73GB1J470J	CHIP R 47 J 1/16W		R168			RK73GB1J124J	CHIP R 120K J 1/16W	
R101			RK73GB1J100J	CHIP R 10 J 1/16W		R169			RK73GB1J103J	CHIP R 10K J 1/16W	
R102			RK73GB1J680J	CHIP R 68 J 1/16W		R170			RK73GB1J124J	CHIP R 120K J 1/16W	
R103			RK73GB1J101J	CHIP R 100 J 1/16W		R171,172			RK73GB1J104J	CHIP R 100K J 1/16W	
R104			RK73GB1J100J	CHIP R 10 J 1/16W		R173,174			RK73GB1J103J	CHIP R 10K J 1/16W	
R105			RK73GB1J680J	CHIP R 68 J 1/16W		R175			RK73GB1J224J	CHIP R 220K J 1/16W	
R106			RK73GB1J222J	CHIP R 2.2K J 1/16W		R176-178			RK73GB1J104J	CHIP R 100K J 1/16W	
R107			RK73GB1J564J	CHIP R 560K J 1/16W		R179			R92-0670-05	CHIP R 0 OHM	
R108			RK73GB1J473J	CHIP R 47K J 1/16W		R180,181			RK73GB1J102J	CHIP R 10K J 1/16W	
R109			RK73GB1J223J	CHIP R 22K J 1/16W		R182			R92-0670-05	CHIP R 0 OHM	
R110			RK73GB1J101J	CHIP R 100 J 1/16W		R183			RK73GB1J560J	CHIP R 56 J 1/16W	
R111			RK73GB1J222J	CHIP R 2.2K J 1/16W		R184			RK73GB1J102J	CHIP R 10K J 1/16W	
R112			RK73GB1J223J	CHIP R 22K J 1/16W		R185			RK73GB1J180J	CHIP R 18 J 1/16W	
R113			RK73GB1J103J	CHIP R 10K J 1/16W		R186			RK73GB1J102J	CHIP R 10K J 1/16W	
R114			RK73GB1J394J	CHIP R 390K J 1/16W		R187			RK73GB1J180J	CHIP R 18 J 1/16W	
R115,116			RK73GB1J222J	CHIP R 2.2K J 1/16W		R188-191			R92-1252-05	CHIP R 0 OHM	
R117			RK73GB1J101J	CHIP R 100 J 1/16W		R193			RK73FB2A220J	CHIP R 22 J 1/10W	
R118			RK73GB1J104J	CHIP R 100K J 1/16W		R194			RK73GB1J224J	CHIP R 220K J 1/16W	
R119			RK73GB1J393J	CHIP R 39K J 1/16W		D1			1SS355	DIODE	
R120			R92-0679-05	CHIP R 0 OHM		D2-4			1SV283	VARIABLE CAPACITANCE DIODE	
R121			RK73GB1J104J	CHIP R 100K J 1/16W		D6			1SV283	VARIABLE CAPACITANCE DIODE	
R122			RK73GB1J101J	CHIP R 100 J 1/16W		D9			1SV283	VARIABLE CAPACITANCE DIODE	
R123			RK73GB1J681J	CHIP R 680 J 1/16W		D10			DAN235K	DIODE	
R124			RK73GB1J223J	CHIP R 22K J 1/16W		D11			DAN202U	DIODE	
R125			RK73GB1J103J	CHIP R 10K J 1/16W		IC1			SA7025DK	IC (PLL SYSTEM)	
R126			RK73GB1J183J	CHIP R 18K J 1/16W		IC2			NJM78L05UA	IC (VOLTAGE REGULATOR/ +5V)	
R127			RK73GB1J681J	CHIP R 680 J 1/16W		IC3			BU4094BCFV	IC (8bit SHIFT/STORE REGISTER)	
R128			RK73GB1J680J	CHIP R 68 J 1/16W		IC4			TA7808S	IC (REGULATOR)	
R129			RK73GB1J152J	CHIP R 1.5K J 1/16W		IC5			NJM2904E	IC (OP AMP X2)	
R130			RK73GB1J101J	CHIP R 100 J 1/16W		IC6			BU4053BCF	IC (AUDIO SW)	
R131			RK73GB1J470J	CHIP R 47 J 1/16W		IC7,8			TA31137FN	IC (IF IC)	
R132			RK73GB1J103J	CHIP R 10K J 1/16W		IC9			M62364FP	IC (D/A CONVERTER)	
R133			RK73GB1J680J	CHIP R 68 J 1/16W		IC10			AT2408N10SI2 5	IC (8Kbit SERIAL EEPROM)	
R134			RK73GB1J152J	CHIP R 1.5K J 1/16W		IC11,12			NJM4558E	IC (OP AMP X2)	
R135			RK73GB1J103J	CHIP R 10K J 1/16W		IC13			NJM78L08UA	IC (VOLTAGE REGULATOR/ +8V)	
R136			RK73GB1J470J	CHIP R 47 J 1/16W		IC14			NJM2904E	IC (OP AMP X2)	
R137			RK73GB1J100J	CHIP R 10 J 1/16W		IC15			LMX1511TMX	IC (PLL FREQUENCY SYNTHESIZER)	
R138			RK73GB1J680J	CHIP R 68 J 1/16W		IC16			NJM78L05UA	IC (VOLTAGE REGULATOR/ +5V)	
R139			RK73GB1J223J	CHIP R 22K J 1/16W							

## PARTS LIST

### RX UNIT (X55-3040-10)

Ref. No.	Address	New parts	Parts No.	Description	Destination
IC17			NJM78L08UA	IC (VOLTAGE REGULATOR/ +8V)	
IC18			TC4S81F	IC (UNLOCK COMPALETER)	
IC19			TC74HC14AF	IC (SCHMITT INVERTER)	
Q1			2SC3357	TRANSISTOR	
Q3			2SC3356	TRANSISTOR	
Q5			2SC3357	TRANSISTOR	
Q6			2SC4226(R24)	TRANSISTOR	
Q7			2SC3357	TRANSISTOR	
Q8,9			2SK508NV(K53)	FET	
Q10			2SC3722K(S)	TRANSISTOR	
Q12			2SC3722K(S)	TRANSISTOR	
Q13			DTC114EUA	DIGITAL TRANSISTOR	
Q14			2SC4226(R24)	TRANSISTOR	
Q15			2SC4215(Y)	TRANSISTOR	
Q16			2SB1386(R)	TRANSISTOR	
Q17			2SC3722K(S)	TRANSISTOR	
Q18,19			DTC114EUA	DIGITAL TRANSISTOR	
Q20			2SB1386(R)	TRANSISTOR	
Q21			2SK508NV(K52)	FET	
Q22			DTC114EUA	DIGITAL TRANSISTOR	
Q23			2SC4215(Y)	TRANSISTOR	
Q24,25			2SC3357	TRANSISTOR	
Q26			2SC4081(R)	TRANSISTOR	
Q27			2SC4215(Y)	TRANSISTOR	
Q28			2SC4081(R)	TRANSISTOR	
Q29			DTC114EUA	DIGITAL TRANSISTOR	
Q30			2SC4215(Y)	TRANSISTOR	
Q31,32			2SC3357	TRANSISTOR	
Q33			2SC4215(Y)	TRANSISTOR	
Q34,35			2SJ106(GR)	FET	
Q36-38			DTC114EUA	DIGITAL TRANSISTOR	
TH1,2			157-302-65801	THERMISTOR	
A1		*	W02-1940-05	DBM	

### TX UNIT (X56-3030-10)

C1,2			CK73GB1H102K	CHIP C	100PF	K
C3,4			CK73GB1H471K	CHIP C	470PF	K
C5,6			CC73FCH1H070B	CHIP C	7.0PF	B
C7		*	CC73FCH1H120G	CHIP C	12PF	G
C8			CC73FCH1H040B	CHIP C	4.0PF	B
C9			CC73FCH1H100D	CHIP C	10PF	D
C10			CC73FCH1H050B	CHIP C	5.0PF	B
C11			CK73GB1E103K	CHIP C	0.010UF	K
C12			CC73GCH1H0R5B	CHIP C	0.5PF	B
C13			CK73GB1H471K	CHIP C	470PF	K
C14			CC73GCH1H0R5B	CHIP C	0.5PF	B
C15,16			CK73GB1H102K	CHIP C	1000PF	K
C17,18			CC73FCH1H070D	CHIP C	7.0PF	D
C19-21			CK73GB1H102K	CHIP C	1000PF	K
C22			CC73FCH1H090D	CHIP C	9.0PF	D
C23			CC73FCH1H070D	CHIP C	7.0PF	D
C24			CC73FCH1H110J	CHIP C	11PF	J
C25			CC73FCH1H080D	CHIP C	8.0PF	D
C26			CK73GB1H102K	CHIP C	1000PF	K
C27,28			CC73GCH1H0R5B	CHIP C	0.5PF	B
C29		*	C92-0728-05	ELECTROLYTIC	470UH	16WV
C30			CK73GB1H471K	CHIP C	470PF	K
C31			CK73GB1H103K	CHIP C	0.010UF	K
C32			C92-0633-05	CHIP-TAN	22UF	10WV

Ref. No.	Address	New parts	Parts No.	Description	Destination
C33			CK73GB1H471K	CHIP C	470PF K
C34			CK73GB1H103K	CHIP C	0.010UF K
C35,36			CC73GCH1H040C	CHIP C	4.0PF C
C37			CK73GB1H471K	CHIP C	470PF K
C38			CC73GCH1H050C	CHIP C	5.0PF C
C39			CK73GB1H471K	CHIP C	470PF K
C40			C92-0633-05	CHIP-TAN	22UF 10WV
C41			CK73FB1E104K	CHIP C	0.10UF K
C42			CK73GB1H103K	CHIP C	0.010UF K
C43			CC73GCH1H040C	CHIP C	4.0PF C
C44			CC73GCH1H020C	CHIP C	2.0PF C
C45			C92-0633-05	CHIP-TAN	22UF 10WV
C46			CK73FB1E104K	CHIP C	0.10UF K
C47			CK73GB1H103K	CHIP C	0.010UF K
C48			CK73GB1H471K	CHIP C	470PF K
C49			CC73GCH1H020C	CHIP C	2.0PF C
C50			CK73GB1H471K	CHIP C	470PF K
C51			CC73GCH1H100D	CHIP C	10PF D
C52			CK73GB1H102K	CHIP C	1000PF K
C53-55			CK73GB1H471K	CHIP C	470PF K
C56			CC73GCH1H070D	CHIP C	7.0PF D
C57			C92-0560-05	CHIP-TAN	10UF 6.3WV
C58-60			CK73GB1H471K	CHIP C	470PF K
C61			CK73GB1H102K	CHIP C	1000PF K
C62,63			CK73GB1H471K	CHIP C	470PF K
C64			CC73GCH1H151J	CHIP C	150PF J
C65			CC73GCH1H101J	CHIP C	100PF J
C66			CK73GB1H102K	CHIP C	1000PF K
C67			CK73GB1H471K	CHIP C	470PF K
C100			CC73GCH1H070D	CHIP C	7.0PF D
C101			CK73GB1H103K	CHIP C	0.010UF K
C102			C92-0502-05	CHIP-TAN	0.33UF 35WV
C103,104			CK73GB1H103K	CHIP C	0.010UF K
C105			CK73GB1H102K	CHIP C	1000PF K
C106			CK73GB1H471K	CHIP C	470PF K
C107			C92-0606-05	CHIP-TAN	4.7UF 10WV
C108,109			CK73GB1H102K	CHIP C	1000PF K
C110			CK73GB1H103K	CHIP C	0.010UF K
C111			C92-0001-05	CHIP-C	0.1UF 35WV
C112			CK73GB1H102K	CHIP C	1000PF K
C113			CC73GCH1H020C	CHIP C	2.0PF C
C114			CK73GB1H103K	CHIP C	0.010UF K
C116			CK73GB1H103K	CHIP C	0.010UF K
C117			CC73GCH1H101J	CHIP C	100PF J
C118-120			CK73GB1H102K	CHIP C	1000PF K
C121			CK73FB1E104K	CHIP C	0.10UF K
C122			CC73GCH1H101J	CHIP C	100PF J
C126			CK73GB1H103K	CHIP C	0.010UF K
C127			C92-0589-05	CHIP-TAN	47UF 6.3WV
C128			CK73FB1E104K	CHIP C	0.10UF K
C130			CK73GB1H103K	CHIP C	0.010UF K
C131			C92-0628-05	CHIP-TAN	10UF 10WV
C133			C92-0628-05	CHIP-TAN	10UF 10WV
C135,136			C92-0628-05	CHIP-TAN	10UF 10WV
C137			CC73GCH1H100D	CHIP C	10PF D
C138			C92-0628-05	CHIP-TAN	10UF 10WV
C139			C92-0004-05	CHIP-TAN	1.0UF 16WV
C140			CK73GB1H103K	CHIP C	0.010UF K
C141,142			CK73GB1H102K	CHIP C	1000PF K
C143			C92-0512-05	CHIP-TAN	1.0UF 16WV

## PARTS LIST

TX UNIT (X56-3030-10)

Ref. No.	Address	New parts	Parts No.	Description	Destination	Ref. No.	Address	New parts	Parts No.	Description	Destination
C144			CK73GB1H102K	CHIP C 1000PF K		C302			CK73GB1H471K	CHIP C 470PF K	
C145			CK73GB1H103K	CHIP C 0.010UF K		C303			CK73GB1H102K	CHIP C 1000PF K	
C146			CK73GB1H471K	CHIP C 470PF K		C304			CK73GB1H471K	CHIP C 470PF K	
C147			CK73FB1E104K	CHIP C 0.10UF K		C305			CK73GB1E103K	CHIP C 0.010UF K	
C168			C92-0633-05	CHIP-TAN 22UF 10WV		C307			CM73F2H020C	CHIP C 2 0PF C	
C169			CK73GB1H103K	CHIP C 0.010UF K		C308			CK73GB1H471K	CHIP C 470PF K	
C170			CK73FB1E104K	CHIP C 0.10UF K		C309			CK73GB1E103K	CHIP C 0 010UF K	
C173			CK73GB1H103K	CHIP C 0.010UF K		C310			CK73FB1E104K	CHIP C 0.10UF K	
C174			C92-0589-05	CHIP-TAN 47UF 6.3WV		C311	*		C92-0729-05	ELECTROLYTIC 330UH 25WV	
C175			CK73FB1E104K	CHIP C 0.10UF K		C312			CM73F2H080D	CHIP C 8 0PF D	
C201			C92-0003-05	CHIP-TAN 0.47UF 25WV		C313			CK73GB1H102K	CHIP C 1000PF K	
C202-204			CK73GB1H103K	CHIP C 0.010UF K		C315			CM73F2H100D	CHIP C 10PF D	
C205			C92-0633-05	CHIP-TAN 22UF 10WV		C316			CM73F2H080D	CHIP C 8 0PF D	
C206,207			CC73GCH1H271J	CHIP C 270PF J		C317	*		C92-0729-05	ELECTROLYTIC 330UH 25WV	
C208			C92-0606-05	CHIP-TAN 4.7UF 10WV		C318			CK73GB1H562K	CHIP C 5600PF K	
C209			C92-0519-05	CHIP-TAN 1.0UF 25WV		C319-322			CK73GB1H471K	CHIP C 470PF K	
C210			CC73GCH1H151J	CHIP C 150PF J		C323-328			CK73GB1H102K	CHIP C 1000PF K	
C211			CK73GB1H103K	CHIP C 0.010UF K		C329			CK73GB1H103K	CHIP C 0.010UF K	
C212			CC73GCH1H151J	CHIP C 150PF J		C330,331			CK73GB1H102K	CHIP C 1000PF K	
C213			CK73GB1H103K	CHIP C 0.010UF K		C332,333			CK73FB1E104K	CHIP C 0.10UF K	
C214			CC73GCH1H100D	CHIP C 10PF D		C334			C92-0003-05	CHIP-TAN 0.47UF 25WV	
C215,216			CK73GB1H103K	CHIP C 0.010UF K		TC1,2			C05-0393-05	CERAMIC TRIMMER CAP(8P)	
C217			CC73GCH1H560J	CHIP C 56PF J		CN1	*		E04-0409-05	RF COAXIAL RECEPTACLE(SMB)	
C218			CK73GB1H103K	CHIP C 0.010UF K		CN2			E40-5758-05	FLAT CABLE CONNECTOR 12P	
C219			CC73GCH1H820J	CHIP C 82PF J		CN3			E40-5736-05	FLAT CABLE CONNECTOR 26P	
C220			CK73GB1H103K	CHIP C 0.010UF K		CN101,102	*		E04-0409-05	RF COAXIAL RECEPTACLE(SMB)	
C221-224			CC73GCH1H271J	CHIP C 270PF J		CN103,104			E40-5538-05	PIN ASSY	
C231,232			CK73GB1H471K	CHIP C 470PF K		CN301	*		E04-0408-05	RF COAXIAL RECEPTACLE(SMB)	
C233			CC73GCH1H080D	CHIP C 8 0PF D		CN302			E40-5758-05	FLAT CABLE CONNECTOR 12P	
C234			CC73GCH1H150J	CHIP C 15PF J		CN304,305			E40-5538-05	PIN ASSY	
C235			CC73GCH1H080D	CHIP C 8.0PF D		CN306,307			E23-0902-05	TERMINAL	
C236			C92-0004-05	CHIP-TAN 1.0UF 16WV		CN308	*		E04-0408-05	RF COAXIAL RECEPTACLE(SMB)	
C237-239			CK73GB1H102K	CHIP C 1000PF K		CN502	*		E40-5783-05	PIN ASSY	
C240			C92-0519-05	CHIP-TAN 1.0UF 25WV		J402			J13-0071-05	FUSE HOLDER	
C241			CK73GB1H103K	CHIP C 0.010UF K		L1,2			L40-1095-34	SMALL FIXED INDUCTOR(1UH)	
C242			C92-0606-05	CHIP-TAN 4.7UF 10WV		L3			L40-1071-36	SMALL FIXED INDUCTOR(10NH)	
C243			CC73GCH1H560J	CHIP C 56PF J		L5,6	*		L34-4545-05	AIR-CORE COIL	
C244			C92-0003-05	CHIP-TAN 0.47UF 25WV		L7-10			L40-1095-34	SMALL FIXED INDUCTOR(1UH)	
C245			CK73GB1H103K	CHIP C 0.010UF K		L11,12			L40-1571-36	SMALL FIXED INDUCTOR(15NH)	
C246,247			CC73GCH1H151J	CHIP C 150PF J		L13			L40-1071-36	SMALL FIXED INDUCTOR(10NH)	
C248			CK73GB1H103K	CHIP C 0.010UF K		L14			L40-1571-36	SMALL FIXED INDUCTOR(15NH)	
C249			CC73GCH1H100D	CHIP C 10PF D		L15			L40-1271-36	SMALL FIXED INDUCTOR(12NH)	
C250-252			CK73GB1H103K	CHIP C 0.010UF K		L18,19			L40-1095-34	SMALL FIXED INDUCTOR(1UH)	
C253			CC73GCH1H560J	CHIP C 56PF J		L101,102			L40-1095-34	SMALL FIXED INDUCTOR(1UH)	
C254			CC73GCH1H271J	CHIP C 270PF J		L103			L40-3385-34	SMALL FIXED INDUCTOR(330NH)	
C255			C92-0633-05	CHIP-TAN 22UF 10WV		L104,105			L40-1015-34	SMALL FIXED INDUCTOR(100UH)	
C256			CK73GB1H103K	CHIP C 0.010UF K		L201			L40-4785-34	SMALL FIXED INDUCTOR(470NH)	
C257			CC73GCH1H271J	CHIP C 270PF J		L202			L40-1095-34	SMALL FIXED INDUCTOR(1UH)	
C258			CK73FB1E104K	CHIP C 0.10UF K		L203			L40-1595-34	SMALL FIXED INDUCTOR(1.5UH)	
C259			CK73GB1H103K	CHIP C 0.010UF K		L204			L40-1015-34	SMALL FIXED INDUCTOR(100UH)	
C260,261			CC73GCH1H050C	CHIP C 5.0PF C		L205,206			L40-4785-34	SMALL FIXED INDUCTOR(470NH)	
C262			CK73GB1H102K	CHIP C 1000PF K		L207			L40-1015-34	SMALL FIXED INDUCTOR(100UH)	
C263			CK73GB1H471K	CHIP C 470PF K		L210			L40-1095-34	SMALL FIXED INDUCTOR(1UH)	
C264,265			CC73GCH1H560J	CHIP C 56PF J		L240			L40-1015-34	SMALL FIXED INDUCTOR(100UH)	
C266,267			CK73GB1E223K	CHIP C 0.022UF K		L241,242			L40-1095-34	SMALL FIXED INDUCTOR(1UH)	
C268			C92-0628-05	CHIP-TAN 10UF 10WV		L243			L40-4785-34	SMALL FIXED INDUCTOR(470NH)	
C269,270			CK73GB1E103K	CHIP C 0.010UF K		L244,245			L40-1871-36	SMALL FIXED INDUCTOR(18NH)	
C271			CK73GB1H471K	CHIP C 470PF K							
C272			CC73GCH1H470J	CHIP C 47PF J							
C301		*	C92-0729-05	ELECTROLYTIC 330UH 25WV							

# TKR-830

## PARTS LIST

TX UNIT (X56-3030-10)

Ref. No.	Address	New parts	Parts No.	Description	Destination	Ref. No.	Address	New parts	Parts No.	Description	Destination
L301			L34-1113-05	AIR-CORE COIL		R100			RK73GB1J103J	CHIP R 10K J 1/16W	
L302,303			L34-1039-05	AIR-CORE COIL		R101			RK73GB1J105J	CHIP R 1 0M J 1/16W	
L304			L79-0558-05	FILTER		R102			RK73GB1J473J	CHIP R 47K J 1/16W	
L305		*	L34-4523-05	AIR-CORE COIL		R103,104			R92-0670-05	CHIP R 0 OHM	
X101		*	L77-1735-05	TCXO (20MHZ)		R105			RK73GB1J332J	CHIP R 3 3K J 1/16W	
X201,202		*	L77-1748-05	CRYSTAL RESONATOR (19.2MHZ)		R106			RK73GB1J101J	CHIP R 100 J 1/16W	
XF210		*	L71-0529-05	MCF(20MHZ 2K)		R107			RK73GB1J471J	CHIP R 470 J 1/16W	
R1,2			R92-1252-05	CHIP R 0 OHM		R108			RK73GB1J183J	CHIP R 18K J 1/16W	
R3,4			RK73GB1J473J	CHIP R 47K J 1/16W		R109-111			R92-0670-05	CHIP R 0 OHM	
R5,6			RK73GB1J104J	CHIP R 100K J 1/16W		R112			RK73GB1J183J	CHIP R 18K J 1/16W	
R7			RK73GB1J683J	CHIP R 68K J 1/16W		R113			RK73GB1J102J	CHIP R 1 0K J 1/16W	
R8			RK73GB1J473J	CHIP R 47K J 1/16W		R114			RK73GB1J222J	CHIP R 2 2K J 1/16W	
R9			RK73GB1J101J	CHIP R 100 J 1/16W		R115			RK73GB1J101J	CHIP R 100 J 1/16W	
R10,11			R92-1252-05	CHIP R 0 OHM		R116			RK73GB1J472J	CHIP R 4 7K J 1/16W	
R12			RK73GB1J101J	CHIP R 100 J 1/16W		R117			RK73GB1J101J	CHIP R 100 J 1/16W	
R13			RK73GB1J181J	CHIP R 180 J 1/16W		R118,119			RK73GB1J103J	CHIP R 10K J 1/16W	
R14			RK73GB1J103J	CHIP R 10K J 1/16W		R120			RK73GB1J102J	CHIP R 1.0K J 1/16W	
R15			RK73GB1J331J	CHIP R 330 J 1/16W		R121,122			RK73GB1J101J	CHIP R 100 J 1/16W	
R16			RK73GB1J103J	CHIP R 10K J 1/16W		R123			RK73GB1J103J	CHIP R 10K J 1/16W	
R17			RK73GB1J473J	CHIP R 47K J 1/16W		R124			RK73GB1J102J	CHIP R 1 0K J 1/16W	
R18			RK73GB1J103J	CHIP R 10K J 1/16W		R129			RK73GB1J102J	CHIP R 1 0K J 1/16W	
R19			RK73GB1J470J	CHIP R 47 J 1/16W		R130			R92-0679-05	CHIP R 0 OHM	
R20			RK73GB1J103J	CHIP R 10K J 1/16W		R131			RK73GB1J102J	CHIP R 1 0K J 1/16W	
R21			RK73GB1J470J	CHIP R 47 J 1/16W		R132			RK73GB1J124J	CHIP R 120K J 1/16W	
R22			RK73GB1J103J	CHIP R 10K J 1/16W		R133			RK73GB1J104J	CHIP R 100K J 1/16W	
R23			RK73GB1J183J	CHIP R 18K J 1/16W		R134-136			R92-0679-05	CHIP R 0 OHM	
R24			RK73GB1J101J	CHIP R 100 J 1/16W		R137			RK73GB1J103J	CHIP R 10K J 1/16W	
R25			RK73GB1J472J	CHIP R 4 7K J 1/16W		R138			RK73GB1J124J	CHIP R 120K J 1/16W	
R26			RK73GB1J220J	CHIP R 22 J 1/16W		R139			RK73GB1J104J	CHIP R 100K J 1/16W	
R27			RK73GB1J101J	CHIP R 100 J 1/16W		R140			RK73GB1J474J	CHIP R 470K J 1/16W	
R28			RK73GB1J103J	CHIP R 10K J 1/16W		R141			RK73GB1J102J	CHIP R 1 0K J 1/16W	
R29			RK73GB1J183J	CHIP R 18K J 1/16W		R142			RK73GB1J104J	CHIP R 100K J 1/16W	
R30			RK73GB1J103J	CHIP R 10K J 1/16W		R143			RK73GB1J473J	CHIP R 47K J 1/16W	
R31			RK73GB1J101J	CHIP R 100 J 1/16W		R144			RK73GB1J334J	CHIP R 330K J 1/16W	
R32			RK73GB1J471J	CHIP R 470 J 1/16W		R145			RK73GB1J102J	CHIP R 1 0K J 1/16W	
R33			RK73GB1J103J	CHIP R 10K J 1/16W		R146			RK73GB1J101J	CHIP R 100 J 1/16W	
R34			RK73GB1J222J	CHIP R 2 2K J 1/16W		R147			RK73GB1J102J	CHIP R 1 0K J 1/16W	
R35			RK73GB1J182J	CHIP R 1 8K J 1/16W		R148			RK73GB1J101J	CHIP R 100 J 1/16W	
R36			RK73GB1J472J	CHIP R 4 7K J 1/16W		R201,202			R92-1252-05	CHIP R 0 OHM	
R37			RK73GB1J122J	CHIP R 1 2K J 1/16W		R203			RK73GB1J223J	CHIP R 22K J 1/16W	
R38			RK73GB1J822J	CHIP R 8 2K J 1/16W		R204			RK73GB1J103J	CHIP R 10K J 1/16W	
R39			RK73GB1J471J	CHIP R 470 J 1/16W		R209			RK73GB1J102J	CHIP R 1 0K J 1/16W	
R40			RK73GB1J101J	CHIP R 100 J 1/16W		R210			RK73GB1J224J	CHIP R 220K J 1/16W	
R41			RK73GB1J152J	CHIP R 1 5K J 1/16W		R211			RK73GB1J103J	CHIP R 10K J 1/16W	
R42			RK73GB1J471J	CHIP R 470 J 1/16W		R212			RK73GB1J223J	CHIP R 22K J 1/16W	
R43			RK73GB1J221J	CHIP R 220 J 1/16W		R213			RK73GB1J821J	CHIP R 820 J 1/16W	
R44			RK73GB1J681J	CHIP R 680 J 1/16W		R214			RK73GB1J101J	CHIP R 100 J 1/16W	
R45			RK73GB1J100J	CHIP R 10 J 1/16W		R215			RK73GB1J103J	CHIP R 10K J 1/16W	
R46			RK73FB2A470J	CHIP R 47 J 1/10W		R216			RK73GB1J223J	CHIP R 22K J 1/16W	
R47			RK73GB1J222J	CHIP R 2 2K J 1/16W		R217,218			RK73GB1J471J	CHIP R 470 J 1/16W	
R48			RK73GB1J103J	CHIP R 10K J 1/16W		R219			RK73GB1J103J	CHIP R 10K J 1/16W	
R49			RK73GB1J123J	CHIP R 12K J 1/16W		R222			RK73GB1J103J	CHIP R 10K J 1/16W	
R50			RK73GB1J471J	CHIP R 470 J 1/16W		R223			RK73GB1J153J	CHIP R 15K J 1/16W	
R51,52			RK73GB1J101J	CHIP R 100 J 1/16W		R226			RK73GB1J474J	CHIP R 470K J 1/16W	
R53			RK73GB1J120J	CHIP R 12 J 1/16W		R227			RK73GB1J473J	CHIP R 47K J 1/16W	
R54			RK73GB1J223J	CHIP R 22K J 1/16W		R228			RK73GB1J104J	CHIP R 100K J 1/16W	
R55			RK73GB1J101J	CHIP R 100 J 1/16W		R240			RK73GB1J102J	CHIP R 1 0K J 1/16W	
R56			RK73GB1J473J	CHIP R 47K J 1/16W		R241			RK73GB1J103J	CHIP R 10K J 1/16W	
R57			RK73GB1J222J	CHIP R 2 2K J 1/16W		R242			R92-1252-05	CHIP R 0 OHM	
						R243,244			RK73GB1J223J	CHIP R 22K J 1/16W	



# PARTS LIST

# TKR-830

# TKR-830

# PARTS LIST

TX UNIT (X56-3030-10)

Ref. No.	Address	New parts	Parts No.	Description	Destination	Ref. No.	Address	New parts	Parts No.	Description	Destination
R245			RK73GB1J103J	CHIP R 10K J 1/16W		D305			DSM3MA1	DIODE	
R246			RK73GB1J101J	CHIP R 100 J 1/16W		D306			HSM88AS	DIODE	
R247			RK73GB1J821J	CHIP R 820 J 1/16W		D308			HSM88AS	DIODE	
R248			RK73GB1J471J	CHIP R 470 J 1/16W		D310,311		*	MINISMDC075-02	VARISTOR	
R249			RK73GB1J223J	CHIP R 22K J 1/16W		IC1			TA7808S	IC (REGULATOR)	
R250			RK73GB1J103J	CHIP R 10K J 1/16W		IC2			NJM78L08UA	IC (VOLTAGE REGULATOR/+8V)	
R251			R92-1252-05	CHIP R 0 OHM		IC3			M62364FP	IC (D/A CONVERTER)	
R252			RK73GB1J471J	CHIP R 470 J 1/16W		IC4			BU4094BCFV	IC (8bit SHIFT/STORE REGISTER)	
R253			RK73GB1J224J	CHIP R 220K J 1/16W		IC100			TA75S01F	IC (OP AMP)	
R259			R92-0670-05	CHIP R 0 OHM		IC101			LMX1511TMX	IC (PLL FREQUENCY SYNTHESIZER)	
R260			RK73GB1J104J	CHIP R 100K J 1/16W		IC103			NJM78L05UA	IC (VOLTAGE REGULATOR/+5V)	
R261			RK73GB1J470J	CHIP R 47 J 1/16W		IC105			NJM4558E	IC (OP AMP X2)	
R262			RK73GB1J471J	CHIP R 470 J 1/16W		IC106			AT2408N10SI2.5	IC (8kbit SERIAL EEPROM)	
R263			RK73GB1J473J	CHIP R 47K J 1/16W		IC108			NJM78L08UA	IC (VOLTAGE REGULATOR/+8V)	
R264			RK73GB1J273J	CHIP R 27K J 1/16W		IC109			NJM2904E	IC (OP AMP X2)	
R265			RK73GB1J223J	CHIP R 22K J 1/16W		IC110			NJM78L05UA	IC (VOLTAGE REGULATOR/+5V)	
R266			RK73GB1J104J	CHIP R 100K J 1/16W		IC201,202			SA7025DK	IC (PLL SYSTEM)	
R267			RK73GB1J103J	CHIP R 10K J 1/16W		IC203			NJM2904E	IC (OP AMP X2)	
R268			RK73GB1J473J	CHIP R 47K J 1/16W		IC204			NJM2903M	IC (COMPARATOR X2)	
R269			RK73GB1J102J	CHIP R 1.0K J 1/16W		IC205			TC4S81F	IC (UNLOCK COMPALETER)	
R270,271			R92-1201-05	CHIP R 220 J 1/2W		IC301		*	S-AU50M	IC (POWER MODULE)	
R301			RK73GB1J183J	CHIP R 18K J 1/16W		IC302,303			NJM2904E	IC (OP AMP X2)	
R302			RK73GB1J471J	CHIP R 470 J 1/16W		Q1,2			2SK508NV(K52)	FET	
R303			RK73FB2A181J	CHIP R 180 J 1/10W		Q3,4			2SC3722K(S)	TRANSISTOR	
R304			RK73FB2A330J	CHIP R 33 J 1/10W		Q5			2SK1824	FET	
R305			RK73FB2A181J	CHIP R 180 J 1/10W		Q6			2SC4226(R24)	TRANSISTOR	
R306			RK73GB1J103J	CHIP R 10K J 1/16W		Q7			2SC3722K(S)	TRANSISTOR	
R307			R92-1252-05	CHIP R 0 OHM		Q8			DTC114EUA	DIGITAL TRANSISTOR	
R308			RK73GB1J102J	CHIP R 1.0K J 1/16W		Q9		*	2SC4226(R24)	TRANSISTOR	
R310			R92-1201-05	CHIP R 220 J 1/2W		Q10			DTC144EUA	DIGITAL TRANSISTOR	
R311			RK73GB1J473J	CHIP R 47K J 1/16W		Q11			2SB1386(R)	TRANSISTOR	
R312			R92-1201-05	CHIP R 220 J 1/2W		Q12			DTC114EUA	DIGITAL TRANSISTOR	
R313			RK73GB1J102J	CHIP R 1.0K J 1/16W		Q13			2SC4093(R27)	TRANSISTOR	
R314			RK73GB1J105J	CHIP R 1.0M J 1/16W		Q14			2SC3357	TRANSISTOR	
R315			RK73GB1J102J	CHIP R 1.0K J 1/16W		Q15			2SK302(Y)	FET	
R316			RK73GB1J473J	CHIP R 47K J 1/16W		Q16			DTA114EUA	DIGITAL TRANSISTOR	
R317			RK73GB1J104J	CHIP R 100K J 1/16W		Q17			2SA1586(Y,GR)	TRANSISTOR	
R319			RK73GB1J823J	CHIP R 82K J 1/16W		Q18		*	DTC143EUA	DIGITAL TRANSISTOR	
R320			RK73GB1J104J	CHIP R 100K J 1/16W		Q102			2SC4215(Y)	TRANSISTOR	
R321			RK73GB1J223J	CHIP R 22K J 1/16W		Q106			2SC4215(Y)	TRANSISTOR	
R322			RK73GB1J103J	CHIP R 10K J 1/16W		Q107			2SC4226(R24)	TRANSISTOR	
R323			RK73GB1J473J	CHIP R 47K J 1/16W		Q110			DTA114EUA	DIGITAL TRANSISTOR	
R326			RK73GB1J103J	CHIP R 10K J 1/16W		Q111			DTC114EUA	DIGITAL TRANSISTOR	
R328			RK73FB2A330J	CHIP R 33 J 1/10W		Q112,113			2SK1824	FET	
D1-6			1SV283	VARIABLE CAPACITANCE DIODE		Q114			DTA114EUA	DIGITAL TRANSISTOR	
D7			1SV128	DIODE		Q115			2SC4215(Y)	TRANSISTOR	
D8			DA204U	DIODE		Q201,202			2SC4215(Y)	TRANSISTOR	
D10			1SV128	DIODE		Q203			DTC114EUA	DIGITAL TRANSISTOR	
D11,12			1SS355	DIODE		Q205			2SC4226(R24)	TRANSISTOR	
D101			1SV128	DIODE		Q206			2SK1824	FET	
D103			1SV128	DIODE		Q240,241			2SC4215(Y)	TRANSISTOR	
D201-203			1SV283	VARIABLE CAPACITANCE DIODE		Q301			2SC4081(R)	TRANSISTOR	
D205			HSM88AS	DIODE		Q302		*	DTC144EUA	DIGITAL TRANSISTOR	
D206,207			MINISMDC075-02	VARISTOR		Q304,305		*	DTC144EUA	DIGITAL TRANSISTOR	
D240			1SV283	VARIABLE CAPACITANCE DIODE		TH301			157-503-53006	THERMISTOR	
D301			UDZ4.7(B)	ZENER DIODE							
D302			1SS355	DIODE							
D303			ERZ-M14DK220M	SURGE ABSORBER							
D304			1SS355	DIODE							

## CAPACITORS

CC 45 TH 1H 220 J  
1 2 3 4 5 6

1 = Type ... ceramic, electrolytic, etc. 4 = Voltage rating  
2 = Shape ... round, square, ect. 5 = Value  
3 = Temp. coefficient 6 = Tolerance

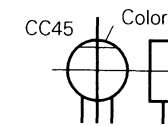

### Capacitor value

010 = 1pF  
100 = 10pF  
101 = 100pF  
102 = 1000pF = 0.001μF  
103 = 0.01μF

Multiplier  
2nd number  
1st number

### Temperature coefficient

1st Word	C	L	P	R	S	T	U
Color*	Black	Red	Orange	Yellow	Green	Blue	Violet
ppm/°C	0	-80	-150	-220	-330	-470	-750

2nd Word	G	H	J	K	L
ppm/°C	± 30	± 60	± 120	± 250	± 500

Example : CC45TH = -470 ± 60ppm/°C

### Tolerance (More than 10pF)

Code	C	D	G	J	K	M	X	Z	P	No code
(%)	± 0.25	± 0.5	± 2	± 5	± 10	± 20	+ 40	+ 80	+ 100	More than 10μF - 10 ~ + 50
							- 20	- 20	- 0	Less than 4.7μF - 10 ~ + 75

### (Less than 10pF)

Code	B	C	D	F	G
(pF)	± 0.1	± 0.25	± 0.5	± 1	± 2

### Voltage rating

2nd word	A	B	C	D	E	F	G	H	J	K	V
0	1.0	1.25	1.6	2.0	2.5	3.15	4.0	5.0	6.3	8.0	-
1	10	12.5	16	20	25	31.5	40	50	63	80	35
2	100	125	160	200	250	315	400	500	630	800	-
3	1000	1250	1600	2000	2500	3150	4000	5000	6300	8000	-

### Chip capacitors

(EX) C C 7 3 F S L 1 H 0 0 0 J  
1 2 3 4 5 6 7

Refer to the table above.

(Chip) (CH, RH, UJ, SL)

(EX) C K 7 3 F F 1 H 0 0 0 Z  
1 2 3 4 5 6 7

(Chip) (B, F)

### Dimension (Chip capacitors)

Dimension code	L	W	T
Empty	5.6 ± 0.5	5.0 ± 0.5	Less than 2.0
A	4.5 ± 0.5	3.2 ± 0.4	Less than 2.0
B	4.5 ± 0.5	2.0 ± 0.3	Less than 2.0
C	4.5 ± 0.5	1.25 ± 0.2	Less than 1.25
D	3.2 ± 0.4	2.5 ± 0.3	Less than 1.5
E	3.0 ± 0.2	1.6 ± 0.2	Less than 1.25
F	2.0 ± 0.3	1.25 ± 0.2	Less than 1.25
G	1.6 ± 0.2	0.8 ± 0.2	Less than 1.0

## RESISTORS

### Chip resistor (Carbon)

(EX) R K 7 3 E B 2 B 0 0 0 J  
1 2 3 4 5 6 7

(Chip) (B, F)

### Carbon resistor (Normal type)

(EX) R D 1 4 B B 2 C 0 0 0 J  
1 2 3 4 5 6 7

1 = Type 5 = Rating wattage  
2 = Shape 6 = Value  
3 = Dimension 7 = Tolerance  
4 = Temp. coefficient

### Dimension

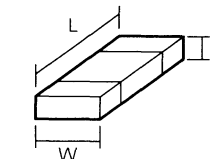

### Dimension (Chip resistor)

Dimension code	L	W	T
E	3.2 ± 0.2	1.6 ± 0.2	1.0
F	2.0 ± 0.3	1.25 ± 0.2	1.0
G	1.6 ± 0.2	0.8 ± 0.2	0.5 ± 0.1

### Rating wattage

Code	Wattage	Code	Wattage	Code	Wattage
1J	1/16W	2C	1/6W	3A	1W
2A	1/10W	2E	1/4W	3D	2W
2B	1/8W	2H	1/2W		

# TKR-830 TKR-830 EXPLODED VIEW

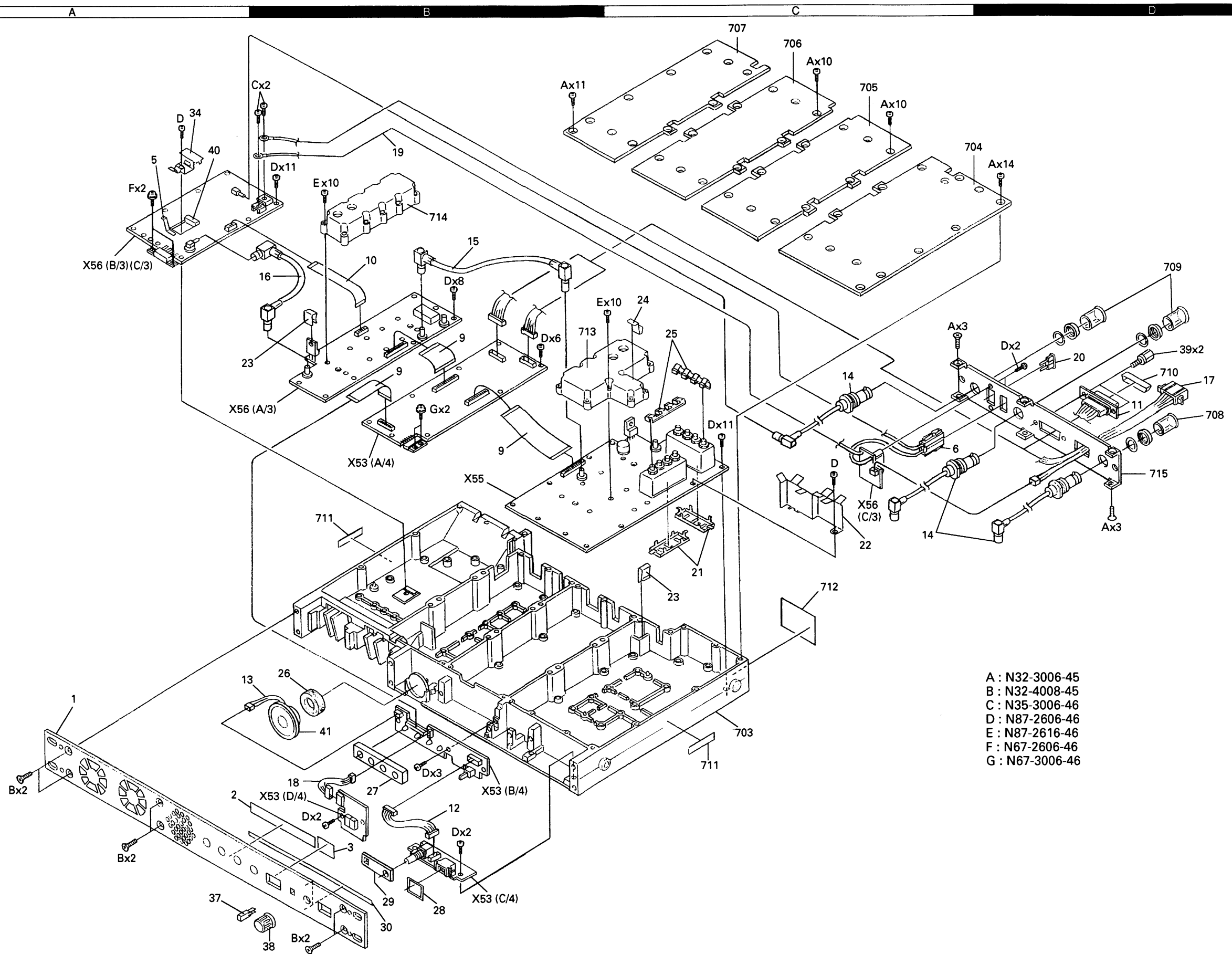

## PACKING

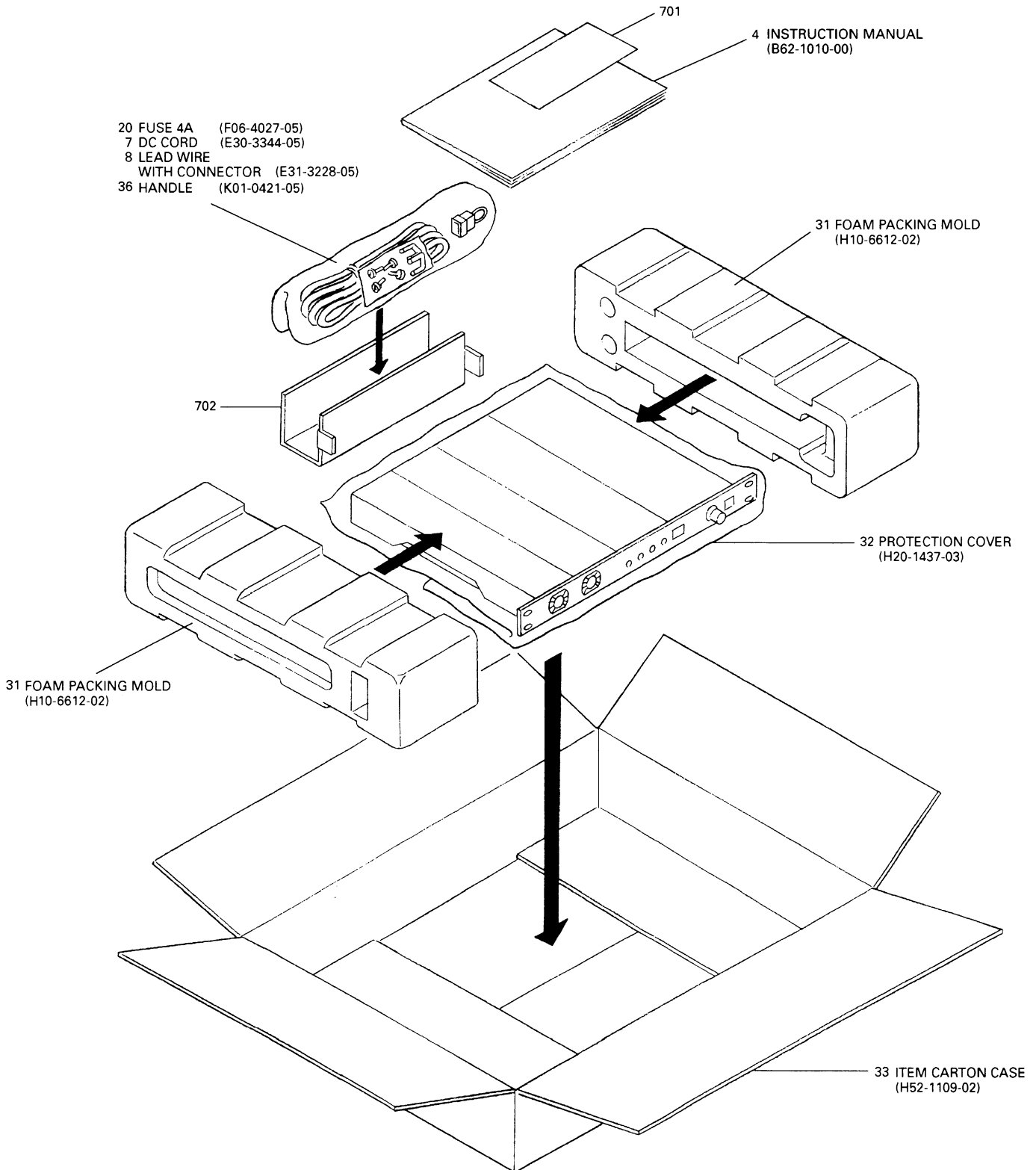

# TKR-830

## TERMINAL FUNCTION

### CONTROL UNIT (X53-3810-10)

Connector No.	Terminal No.	Terminal name	Terminal function
CN1 A/4 for Rxunit CN6	1	RA	RX Audio input (filtered)
	2	RXG	RX Audio ground
	3	DET	Detection signal input
	4	DEG	Detection signal ground
	5	SC	Noise squelch control input
	6	RSSI	Receiving signal strength indicator input
	7	CK	Common clock output
	8	DT	Common data output
	9	RSR	Shift register enable signal output
	10	EVR	Electrical volume loadenable signal output
	11	SCL	EEPROM serial clock output
	12	SDA	EEPROM serial data input/output
	13	DP	PLL data signal output
	14	CP	PLL clock signal output
	15	EPR	RX main PLL strobe signal output
	16	LDR	RX PLL lock detector input
	17	GND	Ground
	18	CVR	RX main PLL lock voltage input
	19	NC	No connection
	20	NC	No connection
	21	B	Power supply output
	22	B	Power supply output
	23	B	Power supply output
	24	NC	No connection
	25	NC	No connection
	26	NC	No connection

CN2 A/4 for Txunit CN3 A/3	1	MOD	Modulation signal output
	2	TO	Signaling signal output
	3	MIG	Microphone ground
	4	EVT	TX Electrical volume enable signal output
	5	EST	TX Shift-register strobe signal output
	6	DT	Data signal output for IC3,IC4
	7	CK	Clock signal output for IC3,IC4
	8	NC	No connection
	9	NC	No connection
	10	SDA	EEPROM serial data input/output
	11	SCL	EEPROM serial clock output

Connector No.	Terminal No.	Terminal name	Terminal function
CN2 A/4 for Txunit CN3 A/3	12	LDT	TX main PLL lock detector input
	13	LDS	TX sub PLL lock detector input
	14	CP	TX PLL clock signal output
	15	EPT	TX main PLL strobe signal output
	16	DP	TX PLL data signal output
	17	EXR	Exit reference detector input
	18	CVT	TX main PLL lock voltage input
	19	REV	Reverse power detector voltage input
	20	FWD	Forward power detector voltage input
	21	GND	Ground
	22	NC	No connection
	23	B	Power supply input
	24	B	Power supply input
	25	B	Power supply input
	26	PAB	Power supply input for AF PAIC

CN20 for 15pin TEST I/O	1	B	Power supply voltage output
	2	FWD	Forward power voltage output
	3	EXR	Reference indicator signal output
	4	CVT	TX main PLL lock voltage output
	5	CVR	RX main PLL lock voltage output
	6	RD	RX signal output (data & voice)
	7	RSSI	Radio signal strength indicator output
	8	SPO	Speaker signal output
	9	SPO	Speaker signal output
	10	SPI	Speaker signal input
	11	GND	Ground
	12	GND	Ground
	13	SPG	Speaker ground
	14	SPG	Speaker ground

## TERMINAL FUNCTION

## CONTROL UNIT (X53-3810-10)

Connector No.	Terminal No.	Terminal name	Terminal function
CN200 B/4 for CONT unit CN17 A/4	1	SPO	Speaker input
	2	SPG	Speaker ground
	3	VLO	AF signal from volume control
	4	VLI	AF signal for volume control
	5	GND	Ground
	6	NC	No connection
	7	SCS	Scan-SW input (No use)
	8	HOK	Hook-SW input (No use)
	9	PTT	PTT output
	10	EXR	Ext reference indicator input
	11	NC	No connection
	12	NC	No connection
	13	B	Power supply input
	14	B	Power supply input
	15	NC	No connection
	16	NC	No connection
	17	TES	TEST SW output
	18	NC	No connection
	19	NC	No connection
	20	7CS	7segment latch signal input
	21	MON	Monitor SW signal output
	22	DT	7segment data signal input
	23	CK	7segment clock signal input
	24	GND	Ground
	25	MI	Microphone signal output
	26	MIG	Microphone signal ground

Connector No.	Terminal No.	Terminal name	Terminal function
CN19 for 25pin Dsub	1	SPM	Speaker mute signal input
	2	CS5	EXT.Channel bit 5 input
	3	RXG	RX signal ground
	4	CS4	EXT.Channel bit 4 input
	5	RA	RX signal output(voice)
	6	CS3	EXT.Channel bit 3 input
	7	RD	RX signal output (data & voice)
	8	CS2	EXT.Channel bit 2 input
	9	TA	TX signal input (voice)
	10	CS1	EXT.Channel bit 1 input
	11	TD	TX signal input (data or signaling)
	12	I/E	INT./EXT channel control select.
	13	DG	Control line's ground
	14	TXG	TX signal ground
	15	AUX3	Auxiliary output 3 (IC9 Q7)
	16	KEY	KEY signal input (no connection)
	17	AUX2	Auxiliary output 2 (IC9 Q6)
	18	SC	SQ control output
	19	AUX1	Auxiliary output 1 (IC9 Q5)
	20	PTT	PTT input
	21	TXD2	RS-232C output (for FPU)
	22	MON	Monitor SW input
	23	RXD2	RS-232C input (for FPU)
	24	NC	No connection
	25	NC	No connection
	26	NC	No connection
	27	NC	No connection
	28	NC	No connection
	29	NC	No connection
	30	NC	No connection

CN205 B/4 CN301 C/4	1	VLO	AF signal from volume control
	2	VLI	AF signal for volume control
	3	GND	Ground
	4	NC	No connection
	5	B	Power supply output
	6	GND	Ground
	7	PTT	PTT input
	8	MIG	Microphone signal ground
	9	MIC	Microphone signal input
	10	HOK	Hook-SW input (No use)
	11	NC	No connection
	12	NC	No connection
	13	NC	No connection
	14	NC	No connection

## TERMINAL FUNCTION

### CONTROL UNIT (X53-3810-10)

Connector No.	Terminal No.	Terminal name	Terminal function
CN201	1	GND	Ground
	2	DS	7segment data signal output
	3	CK	7segment data signal output
	4	7CS	7segment latch signal output
	5	5B2	5V output for D212 & IC205
	6	5A2	5V output D213 & IC206

CN300	1	5A2	5v input for D213 & IC206
	2	5B2	5V input for D212 & IC205
	3	7CS	7segment latch signal input
	4	CK	7segment data signal input
	5	DS	7segment data signal input
	6	GND	Ground

CN203	1	SPG	Speaker ground
	2	SP	Speaker signal output

### TX UNIT(X56-3030-10) A/3

Connector No.	Terminal No.	Terminal name	Terminal function
CN1		DRV OUT	TX driver signal output

CN2 A/3 FINAL unit  CN302 B/3	1	PAB	Power supply for AF PA IC
	2	B	Power supply input
	3	B	Power supply input
	4	B	Power supply input
	5	NC	No connection
	6	FWD	Forward power detector voltage input
	7	REV	Reverse power detector voltage input
	8	PC	Power control signal output
	9	NC	No connection
	10	GND	Ground
	11	8T	TX 8V output
	12	DB	TX 8V output(No use)

CN101	-	EXT REF IN	EXT. reference signal output, coaxial connector
-------	---	------------	-------------------------------------------------

CN102	-	REF OUT	RX PLL reference signal output, coaxial connector
-------	---	---------	---------------------------------------------------

CN103	1	GND	Ground
	2	FB	Fused +B (power supply for fan), No use

CN104	1	GND	Ground
	2	FB	Fused +B (power supply for fan), No use

### FINAL UNIT (X56-3030-10) B/3

Connector No.	Terminal No.	Terminal name	Terminal function
CN301	-	DRV IN	TX driver signal input, coaxial connector

CN304	1	GND	Ground
	2	FB	Fused +B (power supply for fan), No use

CN305	1	GND	Ground
	2	FB	Fused +B (power supply for fan), No use

CN306	-	+B	Power supply input
CN307	-	GND	Ground

CN308	-	RF OUT	TX RF signal output, coaxial connector
-------	---	--------	----------------------------------------

### RX UNIT (X55-3040-10)

Connector No.	Terminal No.	Terminal name	Terminal function
CN1	-	RX IN	Receive signal input, coaxial connector

CN2	-	-	Use for RX helical BPF tuning
-----	---	---	-------------------------------

CN3	1	IN	Use for RX MCF tuning
	2	GND	Use for RX MCF tuning

CN4	1	OUT	Use for wide band MCF tuning
	2	GND	Use for wide band MCF tuning

CN5	1	OUT	Use for narrow band MCF tuning
	2	GND	Use for narrow band MCF tuning

CN7		REF IN	RX PLL reference signal input, coaxial connector
-----	--	--------	--------------------------------------------------

## ADJUSTMENT

### Test Equipment Required for Alignment

No. Test Equipment	Major Specifications	
1. Standard Signal Generator (SSG)	Frequency Range	340 to 520MHz.
	Modulation	Frequency modulation and external modulation.
	Output	0.1μV to greater than 1mV.
2. Power Meter	Input Impedance	50Ω.
	Operation Frequency	340 to 520MHz or more.
	Measurement Capability	Vicinity of 50W.
3. Deviation Meter	Frequency Range	340 to 520MHz.
4. Digital Volt Meter	Measuring Range	1 to 20V DC.
	Accuracy	High input impedance for minimum circuit loading.
5. Oscilloscope		DC through 30MHz.
6. High Sensitivity Frequency Counter	Frequency Range	10Hz to 600MHz.
	Frequency Stability	0.2ppm or less.
7. Ammeter		5A or more.
8. AF Volt Meter (AF VTVM)	Frequency Range	50Hz to 10kHz.
	Voltage Range	3mV to 3V.
9. Audio Generator (AG)	Frequency Range	50Hz to 5kHz.
	Output	0 to 1V.
10. Distortion Meter	Capability	3% or less at 1kHz.
	Input Level	50mV to 10Vrms.
11. Voltmeter	Measuring Range	10 to 1.5V DC or less.
	Input Impedance	50kΩ/V or greater.
12. 4Ω Dummy Load		Approx. 4Ω, 5W

### The Following Parts are Required for Adjustment

- Test cable for local microphone

MIC connector  
front PANEL view

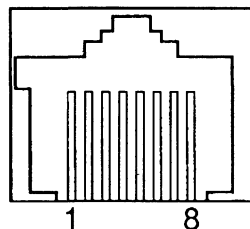

No.	Terminal name & Description
1	NC
2	+B
3	GND
4	PTT/TXD1(PC serial data from radio)
5	MIC G
6	MIC
7	HOOK/RXD1(PC serial data to radio)
8	NC

- The following test cables are recommended.

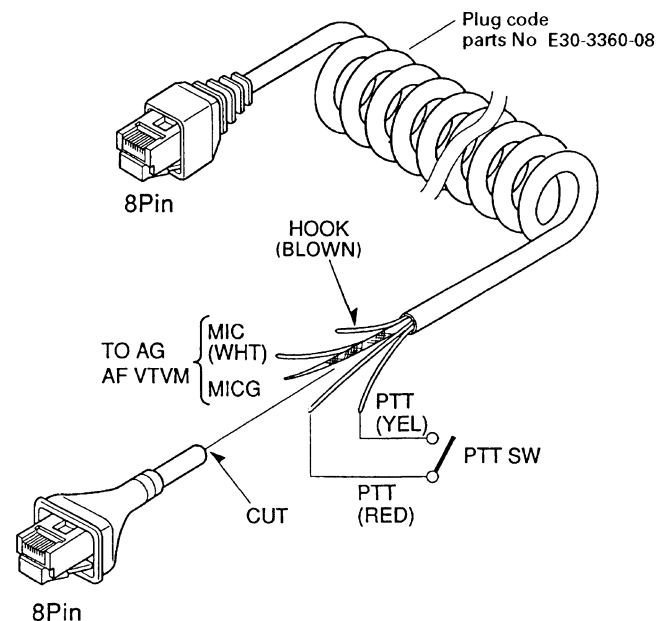

Test cable for Microphone input

# TKR-830

## ADJUSTMENT

### Adjustment Location

•Top view

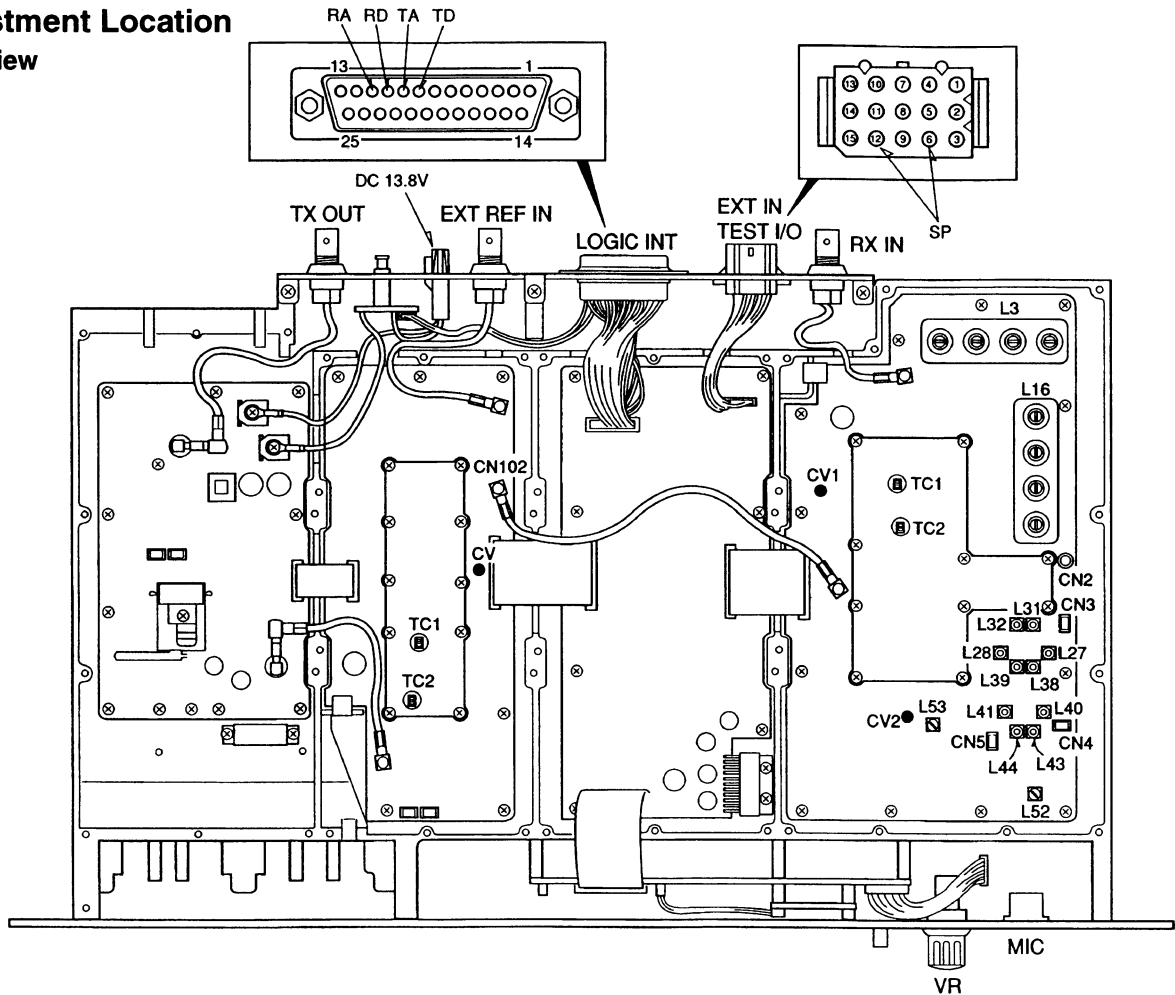

### Section Arrangement (Top view)

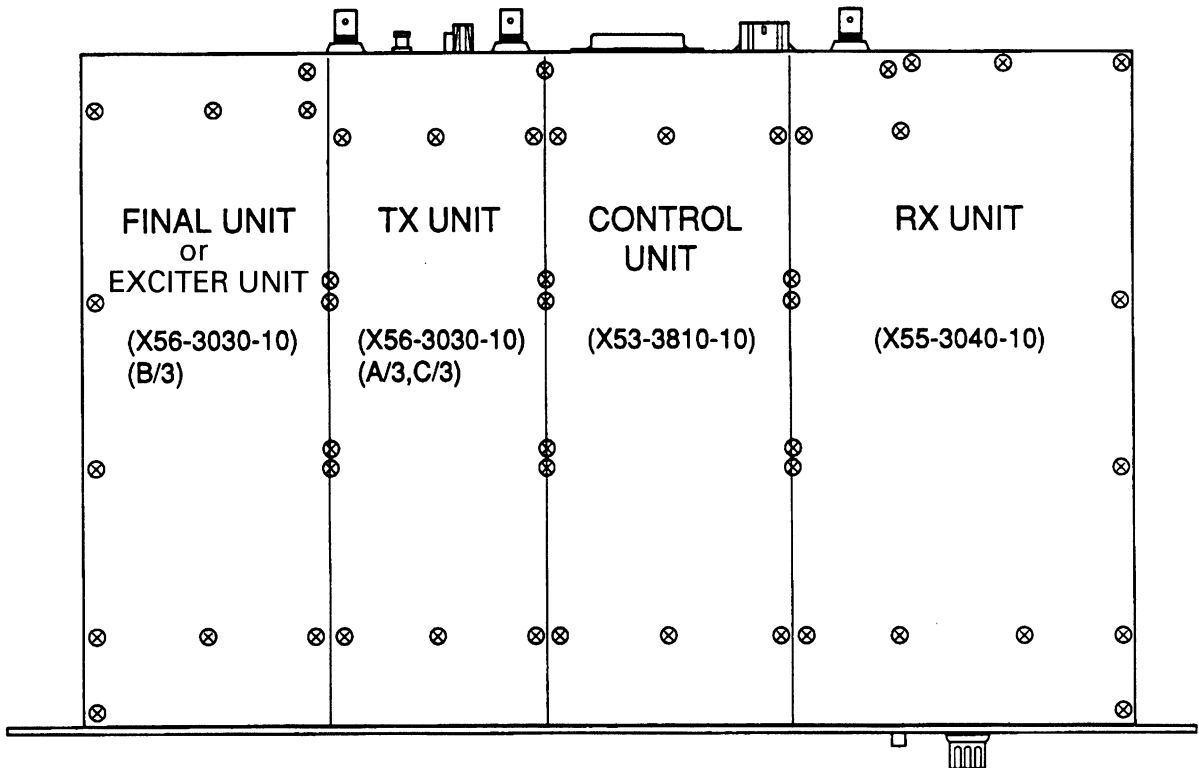



## ADJUSTMENT

## TEST FREQUENCY LIST

CH	RX Frequency	TX Frequency	Beat Shift	W/N	VCO	NOTE
1	450.1000	450.0000	No	Wide	A Low	vcoA Low
2	457.6000	457.5000	No	Wide	A Center	vcoA Center
3	464.9000	464.9500	No	Wide	A High	vcoA High
4	465.1000	465.0000	No	Wide	B Low	vcoB Low
5	472.6000	472.5000	No	Wide	B Center	vcoB Center
6	479.9000	480.0000	No	Wide	B High	vcoB High
7	450.1000	450.0000	No	Narrow	A Low	vcoA Low
8	457.6000	457.5000	No	Narrow	A Center	vcoA Center
9	464.9000	464.9500	No	Narrow	A High	vcoA High
10	465.1000	465.0000	No	Narrow	B Low	vcoB Low
11	472.6000	472.5000	No	Narrow	B Center	vcoB Center
12	479.9000	480.0000	No	Narrow	B High	vcoB High
13	457.6000	457.5000	Yes	Wide	A Center	vcoA Center
14	472.6000	472.5000	Yes	Wide	B Center	vcoB Center
15	462.5000	467.5000	No	Wide	A(Hi)/B(Lo)	
16	467.5000	462.5000	No	Wide	B(Lo)/A(Hi)	
17	462.4000	462.4000	No	Wide	A High	helical filter (center) Low edge
18	467.6000	467.6000	No	Wide	B Low	helical filter (center) High edge
19	462.4000	462.4000	No	Narrow	A High	helical filter (center) Low edge
20	467.6000	467.6000	No	Narrow	B Low	helical filter (center) High edge
21	452.6000	452.6000	No	Wide	A Low	helical filter (Low) High edge
22	452.6000	452.6000	No	Narrow	A Low	helical filter (Low) High edge
23	477.4000	477.4000	No	Wide	B High	helical filter (High) Low edge
24	477.4000	477.4000	No	Narrow	B High	helical filter (High) Low edge
25	450.1000	450.0000	No	Wide	A Low	efficiency warranty Range Low edge
26	465.1000	465.0000	No	Wide	B Low	efficiency warranty Range Center
27	479.9000	480.0000	No	Wide	B High	efficiency warranty Range High edge
28	465.9750	460.9750	No	Wide	B(Lo)/A(Hi)	Repeater
29	465.9750	460.9750	No	Narrow	B(Lo)/A(Hi)	Repeater
30	465.5500	465.5500	No	Wide	B Low	
31	457.6000	472.6000	No	Narrow	A(Ce)/B(Ce)	
32	472.6000	457.6000	No	Narrow	B(Ce)/A(Ce)	

# TKR-830

## ADJUSTMENT

### RX UNIT

Item	Condition	Measurement			Adjustment			Specifications/ Remarks
		Test equipment	Unit	Terminal	Unit	Parts	Method	
1. Setting	1) VOL : OFF 2) 13.8V External power supply 3) POWER : ON							
2. RX Lock Voltage	1) CH6 (RX B Hi) 2) CH4 (RX B Lo) 3) CH3 (RX A Hi) 4) CH1 (RX A Lo) 5) SUB (RX, ANY CHANNEL OK)	DVM	RX.U	CV1	RX.U	TC2	4.5V ADJ Check	±0.1V 1V or more
						TC1	4.5V ADJ Check	±0.1V 1V or more
				CV2			Check	1 to 4.5V
3. BPF ADJ	Connect the TG to RX. IN, then connect CN2 to the spectrum analyzer.	TG spectrum analyzer		RX.IN CN2		L3 L16	Center the frequency you are using, then adjust it to look like the wave on page 58.	Refer to page 58
4. MCF ADJ	Connect the TG to CN3, then connect CN4 to the spectrum analyzer input. 1) CH4 (Wide)				CN3 CN4		L31 L27 L38 L40 L43	Adjust it to look like the wave or page 58.
	Connect the TG to N3, then connect CN5 to the spectrum analyzer input. 2) CH10 (Narrow)			CN3 CN5		L32 L28 L39 L41 L44	Adjust it to look like the wave or page 58.	Refer to page 58
5. Discre ADJ	Connect the SSG to RX.IN 1) CH4 (Wide) MOD : 1kHz DEV : 3kHz LEVEL : -53dBm	SSG AFVM		EXT.SP		L52	Adjust for maximum	
	2) CH10 (narrow) MOD : 1kHz DEV : 1.5kHz LEVEL : -53dBm				L53			
6. Sensitivity check	1) Connect the SSG to RX.IN, then select the channel that the user will use (Wide) MOD : 1kHz DEV : 3kHz LEVEL : -113dBm	SSG Audio,Ana		RX.IN EXT.SP			Check	12dB SINAD or more
	2) Connect the SSG to RX.IN, then select the channel that the user will use (narrow) MOD : 1kHz DEV : 1.5kHz LEVEL : -113dBm							

## ADJUSTMENT

## RX UNIT

Item	Condition	Measurement			Adjustment			Specifications/ Remarks
		Test equipment	Unit	Terminal	Unit	Parts	Method	
7. Analog squelch	1) Connect the SSG to RX.IN, then select the channel that the user will use (Wide) MOD : 1kHz DEV : 3kHz LEVEL : 3dB below to 12dB SINAD level	SSG Audio, Ana VTVM oscilloscope	RX.U	RX.IN	RX.U		PC ADJ Adjust to point of opening squelch	
	EXT.SP 4Ω Load							
8. RSSI squelch	1) Connect the SSG to RX.IN, then select the channel that the user will use (Wide) MOD : 1kHz DEV : 3kHz LEVEL : 3dB below to 12dB SINAD level							
	2) Connect the SSG to RX.IN, then select the channel that the user will use (narrow) MOD : 1kHz DEV : 1.5kHz LEVEL : 3dB below to 12dB SINAD level							
9. RX S/N	1) Connect the SSG to RX.IN, then select the channel that the user will use (Wide) MOD : 1kHz DEV : 3kHz LEVEL : -53dBm						Check	-53dB or less
	2) Connect the SSG to RX.IN, then select the channel that the user will use (narrow) MOD : 1kHz DEV : 1.5kHz LEVEL : -53dBm							-47dB or less
10. RD OUTPUT Level	1) Connect the SSG to RX.IN, then select the channel that the user will use (Wide) MOD : 1kHz DEV : 3kHz LEVEL : -53dBm	SSG DVM		RX.IN			PC ADJ 80mV	±3mV
	2) Connect the SSG to RX.IN, then select the channel that the user will use (narrow) MOD : 1kHz DEV : 1.5kHz LEVEL : -53dBm			D-sub RD Terminal (pin 10) 600Ω Load				

## ADJUSTMENT

### RX UNIT

Item	Condition	Measurement			Adjustment			Specifications/ Remarks
		Test equipment	Unit	Terminal	Unit	Parts	Method	
11. RA OUTPUT Level	1) Connect the SSG to RX.IN, then select the channel that the user will use (Wide) MOD : 1kHz DEV : 3kHz LEVEL : -53dBm	SSG DVM		RX.IN			PC ADJ 400mV	±20mV
	D-sub RA Terminal (pin 11)							
	2) Connect the SSG to RX.IN, then select the channel that the user will use (narrow) MOD : 1kHz DEV : 1.5kHz LEVEL : -53dBm			600Ω Load				

### TX UNIT

Item	Condition	Measurement			Adjustment			Specifications/ Remarks
		Test equipment	Unit	Terminal	Unit	Parts	Method	
12. TX LOCK Voltage	1) CH3 (TX A Hi) 2) CH1 (TX A Lo) 3) CH6 (TX B Hi) 4) CH4 (TX B Lo)	DVM	TX.U A/3	CV		TC1	4.5V ADJ	±0.1V
						TC2	4.5V	Check
13. RX Ref check	Connect a frequency counter to CN102, then measure the frequency. 1) CH2	f.counter		CN102			Check	19.2MHz±1.0ppm
14. EXT. Ref check	• Connect a frequency counter to CN102, then measure the frequency. • Connect a SSG to EXT.REF IN. 1) CH2 LEVEL : 10MHz -10dBm MOD : OFF	f.counter SSG					Check	19.2MHz
	2) frequency=10MHz ±10ppm							19.2MHz ±10ppm
15. TX. Power	Measure the power level at TX.OUT. 1) CH1 (Lo) 2) CH4 (Center) 3) CH6 (Hi)	POWER meter		TX.OUT			PC ADJ 5.0W	±0.1W
16. Max.DEV (Wide)	1) CH1 (VCO-A LO) 2) CH2 (VCO-A center) 3) CH3 (VCO-A Hi) 4) CH4 (VCO-B Lo) 5) CH5 (VCO-B center) 6) CH6 (VCO-B Hi) MOD : 1kHz LEVEL : 50mV (Terminal load)	MOD.ANA	TX.U B/3				PC ADJ 4.1kHz	±0.2kHz
	Max.DEV (narrow)						1) CH7 (VCO-A LO) 2) CH8 (VCO-A center) 3) CH9 (VCO-A Hi) 4) CH10 (VCO-B Lo) 5) CH11 (VCO-B center) 6) CH12 (VCO-B Hi) MOD : 1kHz LEVEL : 50mV (Terminal load)	PC ADJ 1.7kHz

# ADJUSTMENT

## TKR-830

## TKR-830

# ADJUSTMENT

### TX UNIT

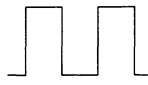
Item	Condition	Measurement			Adjustment		Specifications/ Remarks	
		Test equipment	Unit	Terminal	Unit	Parts		Method
17. MIC, SENCE (Wide)	1) CH2 (VCO-A center) 2) CH5 (VCO-B center) MOD : 1kHz LEVEL : 3mV (Terminal load)	MOD,ANA Oscilloscope	TX.U B/3	TX.OUT			Check	1.5kHz±0.25kHz
MIC, SENCE (narrow)	1) CH8 (VCO-A center) 2) CH11 (VCO-B center) MOD : 1kHz LEVEL : 3mV (Terminal load)						Check	0.75kHz±0.1kHz
18. DQT Balance (Wide)	1) CH2 (VCO-A center) 2) CH5 (VCO-B center) AG.f : 50Hz (square wave) LEVEL : Insert 0.5pp into the D-sub TD terminal (pin 8)		TX.U A/3				PC ADJ Make the demodulation waves into square waves.	 Oscilloscope DC range
DQT Balance (narrow)	1) CH8 (VCO-A center) 2) CH11 (VCO-B center) AG.f : 50Hz (square wave) LEVEL : Insert 0.5pp into the D-sub TD terminal (pin 8)							
19. Signaling DEV (Wide)	1) CH2 (VCO-A center) 2) CH5 (VCO-B center) AG.f : 100Hz (Sine wave) LEVEL : Insert 0.5pp into the D-sub TD terminal (pin 8)						PC ADJ 0.75kHz	±0.05kHz
Signaling DEV (narrow)	1) CH8 (VCO-A center) 2) CH11 (VCO-B center) AG.f : 50Hz (Sine wave) LEVEL : Insert 0.5pp into the D-sub TD terminal (pin 8)							
20. Line Input DEV (Wide)	1) CH4 (Center) AG.f : 1kHz (Sine wave) LEVEL : Insert 140mV into the D-sub TA terminal (pin 9)						PC ADJ 1.5kHz	±0.1kHz
Line Input DEV (narrow)	2) CH10 (Center) AG.f : 1kHz (Sine wave) LEVEL : Insert 140mV into the D-sub TA terminal (pin 9)							
21. TX. S/N (Wide)	1) CH2 (VCO-A center) 2) CH5 (VCO-B center) AG : OFF						Check	-52dB or less
TX. S/N (narrow)	1) CH8 (VCO-A center) 2) CH11 (VCO-B center) AG : OFF							

### BPF-wave

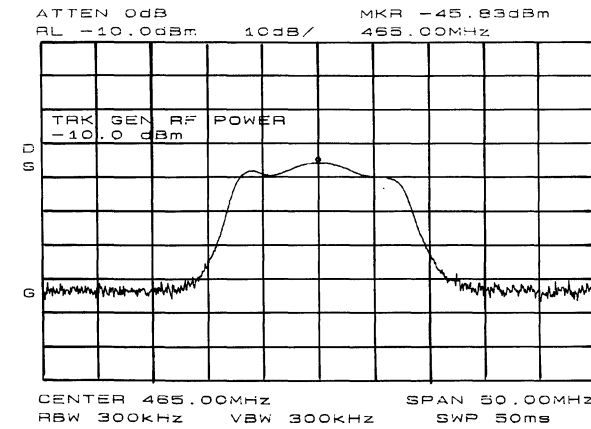

Example : The wave will look like this when using a frequency of 465,000 MHz

### MCF-wave

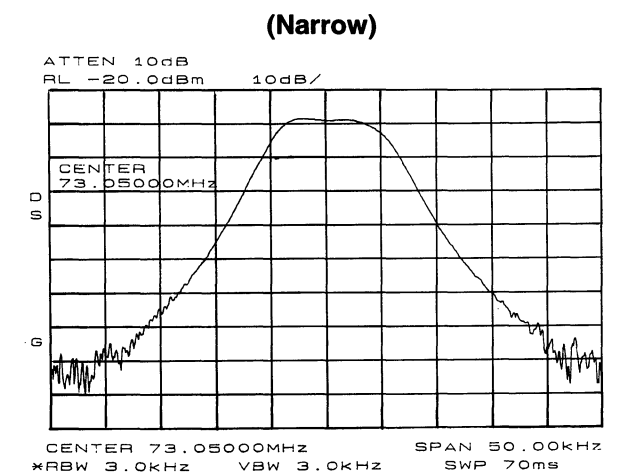
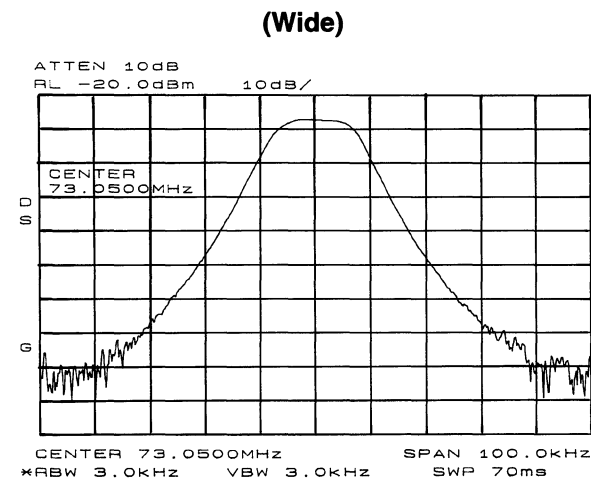

# TKR-830 PC BOARD VIEWS

## CONTROL UNIT (X53-3810-10)(A/4)

Ref. No.	Address
IC1	10H
IC2	6M
IC3	5L
IC4	10K
IC5	10M
IC6	10G
IC7	9N
IC8	5O
IC9	9L
IC10	7J
IC11	6M
IC12	8L
IC13	10N
IC14	5G
IC15	5M
IC101	7L
IC102	7L
IC103	7L
IC104	7G
IC105	6G
IC106	8G
IC107	7E
IC108	6E
IC109	8E
Q1	5M
Q2	7O
Q3	6H
Q4	9O
Q5	6I
Q6	6I
Q7	10P
Q8	7H
Q9	8I
Q10	7H
Q211	5E
D1	10P
D6	9F
D7	9F
D8	10C
D9	10F
D11	10C
D13	8C
D15	10F
D16	9Q
D17	8C
D18	10F
D20	9C
D21	10C
D22	9C
D23	9C
D24	9C
D25	7G
D26	7F
D27	9G
D28	9H
D29	4E
D30	5E
D31	5E
D32	5E
D214	8F

**CONTROL UNIT (X53-3810-10) (A/4) Component side view**

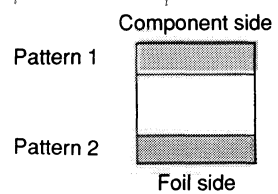
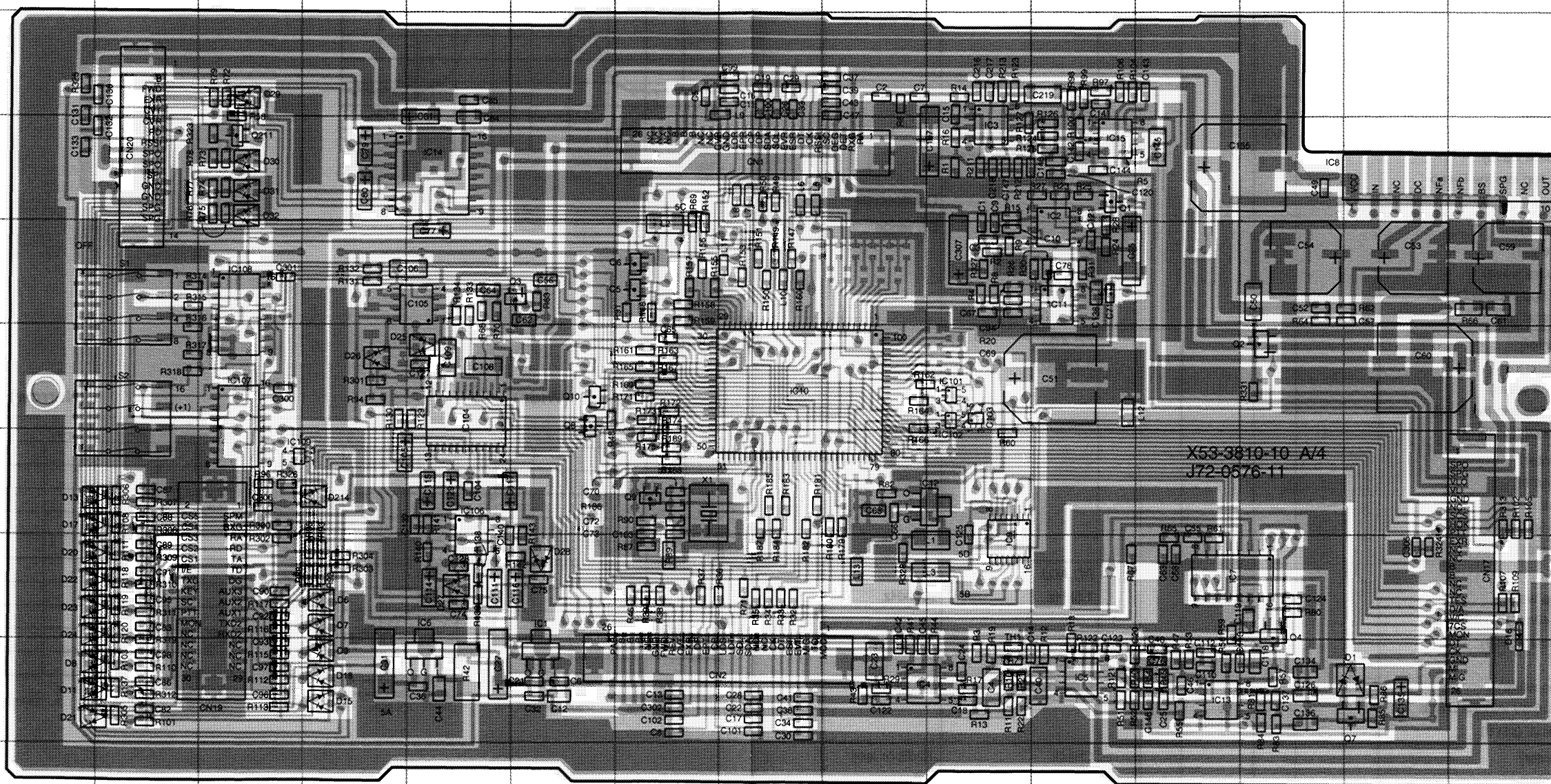

NJM78L08UA  
NJM78L05UA

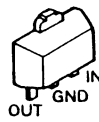

BU4053BCF  
BU4094BCFV

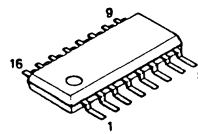

RH5VL42C



TC7S00FU

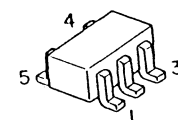

NJM4558E

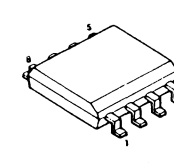

DTC144EUA  
DTC363EK  
2SC4081(R)  
2SC2712(Y)  
2SD1757K  
2SC4215(Y)

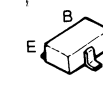



# PC BOARD VIEWS TKR-830

**CONTROL UNIT (X53-3810-10) (B/4) Component side view**

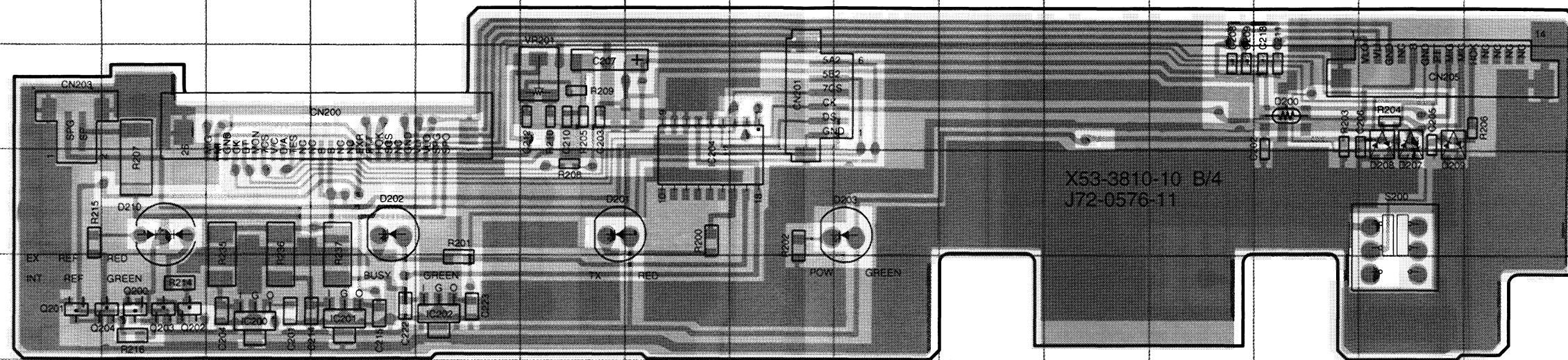

**CONTROL UNIT (X53-3810-10)(B/4)**

Ref. No.	Address
IC200	8E
IC201	8F
IC202	8G
IC204	8H
Q200	8D
Q201	8C
Q202	8D
Q203	8D
Q204	8C
D200	6O
D201	7H
D202	7F
D203	7K
D207	6P
D208	6P
D209	6P
D210	7D

NJM78L08UA

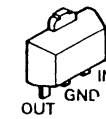

DTC144EUA



BU2114F

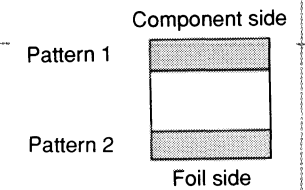
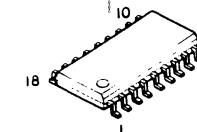

# TKR-830 PC BOARD VIEWS

## CONTROL UNIT (X53-3810-10)(D/4)

Ref. No.	Address
IC205	6P
IC206	9P
D212	7K
D213	5K

**CONTROL UNIT (X53-3810-10) (C/4) Component side view**

**CONTROL UNIT (X53-3810-10) (D/4) Component side view**

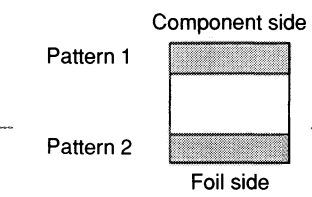
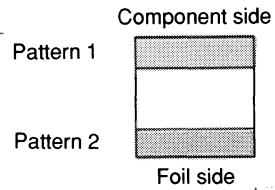
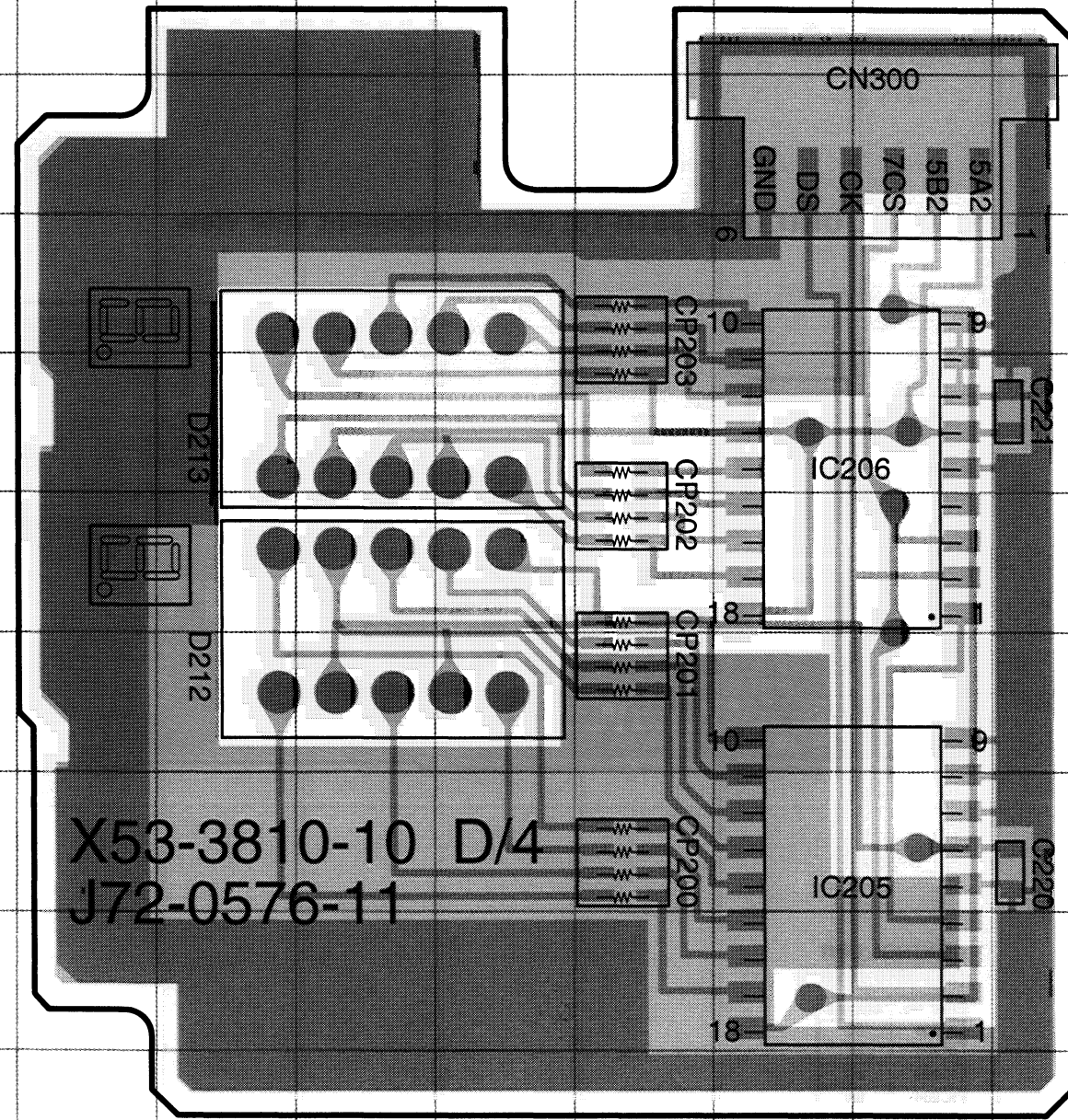
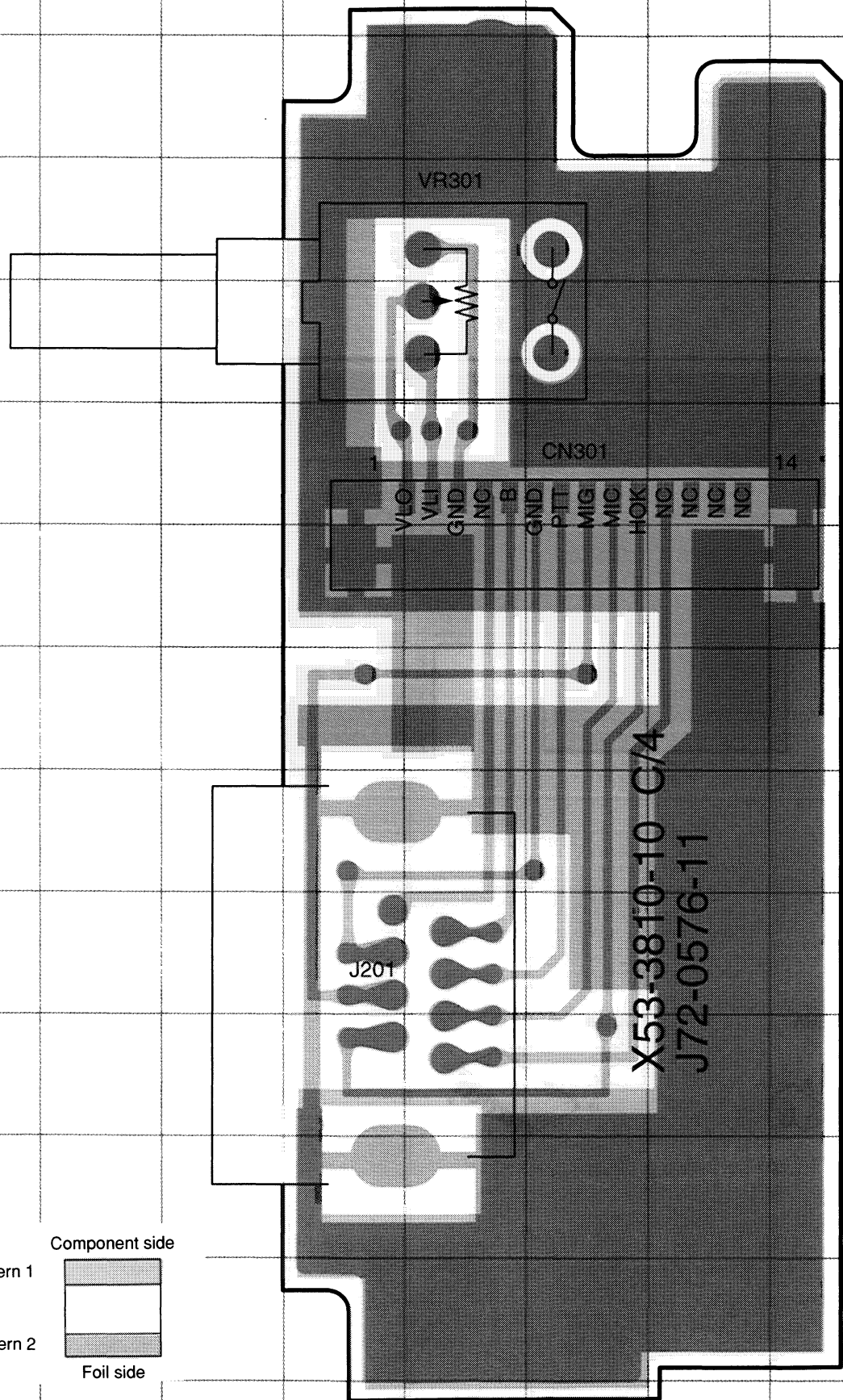

BU2114F

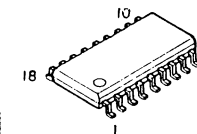



# PC BOARD VIEWS TKR-830

## TX-RX UNIT (X56-3030-10) (A/3) Component side view

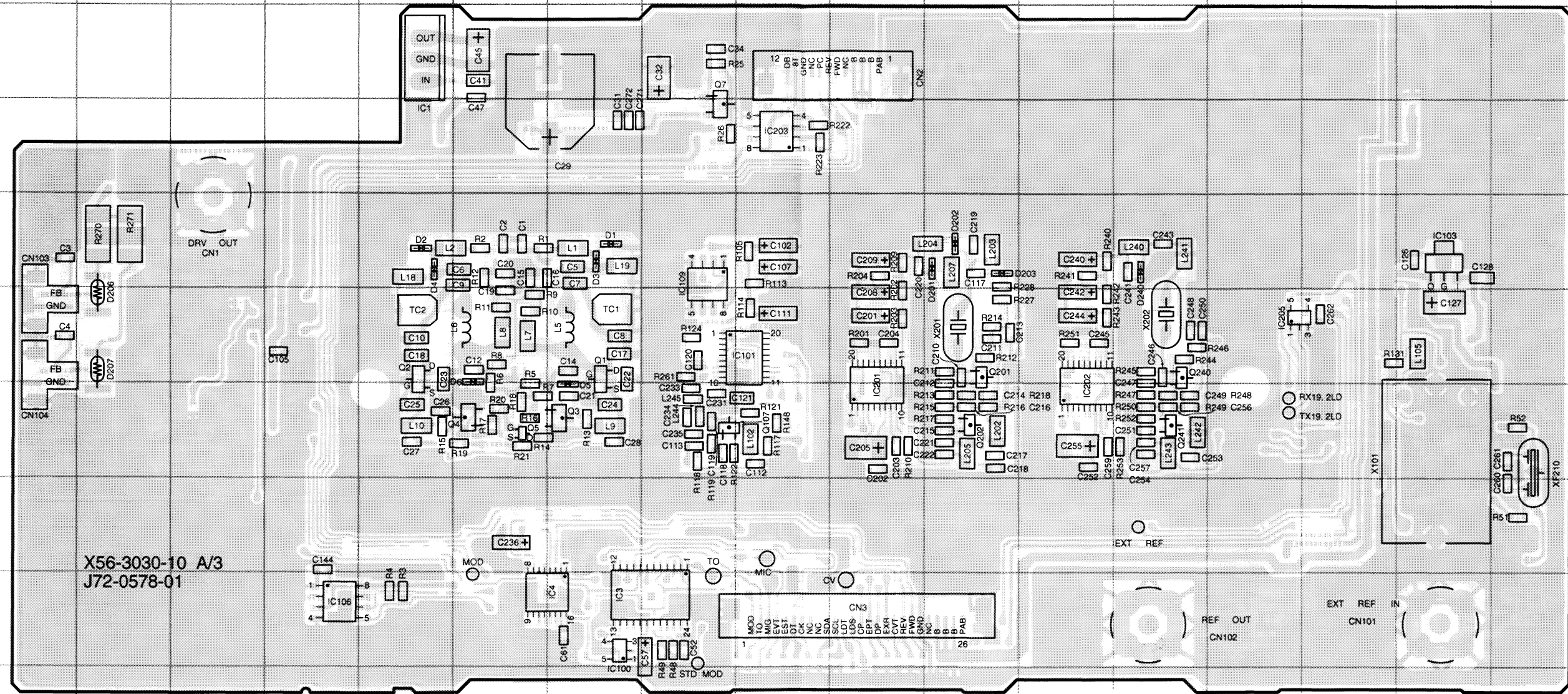

X56-3030-10 A/3  
J72-0578-01

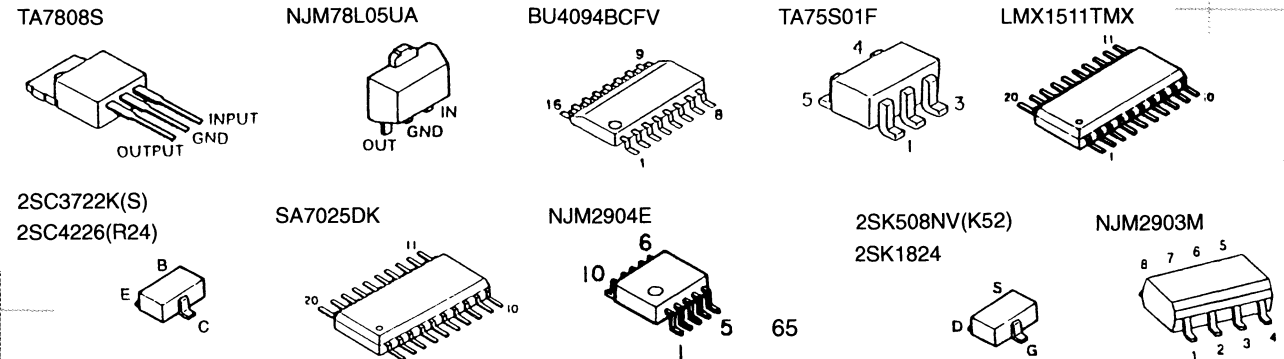
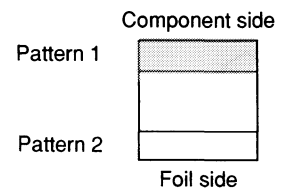

### TX UNIT(X56-3030-10)(A/3) (Component side)

Ref. No.	Address	Ref. No.	Address	Ref. No.	Address
IC1	4Y	Q1	7H	D2	6F
IC3	10H	Q2	7F	D3	6H
IC4	10G	Q3	8H	D4	6F
IC100	10H	Q4	8G	D5	7H
IC101	7J	Q5	8G	D6	7G
IC103	6Q	Q7	4I	D201	6L
IC106	10E	Q107	8I	D202	6L
IC109	6I	Q201	7L	D203	6L
IC201	7K	Q202	8L	D206	6V
IC202	7M	Q240	8N	D207	7V
IC203	5J	Q241	8N	D240	6N
IC205	7O	D1	6H		



# TKR-830 PC BOARD VIEWS

## TX UNIT(X56-3030-10)(A/3) (Foil side)

Ref. No.	Address	Ref. No.	Address
IC2	4H	Q110	7C
IC105	10L	Q111	7C
IC108	4E	Q112	7C
IC110	9J	Q113	7C
IC204	9D	Q114	7C
Q6	8M	Q115	10E
Q8	8P	Q203	8O
Q9	8P	Q205	9B
Q10	7P	Q206	8D
Q11	7O	D7	8Q
Q12	8O	D8	7P
Q13	7Q	D10	8P
Q14	6Q	D11	7P
Q15	8D	D12	7O
Q16	8P	D101	8C
Q17	8K	D103	8C
Q18	8K	D205	9C
Q102	10B		
Q106	9B		

### TX-RX UNIT (X56-3030-10) (A/3) Foil side view

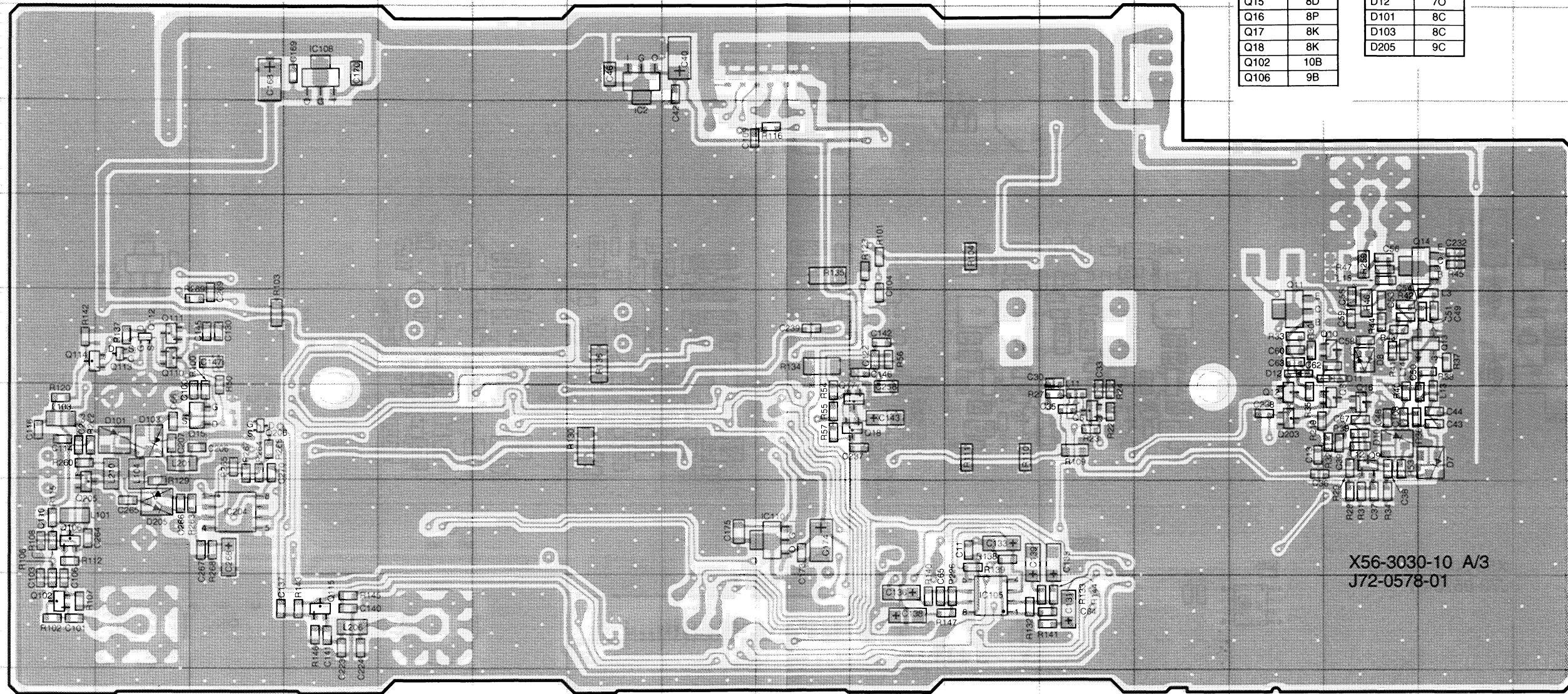

X56-3030-10 A/3  
J72-0578-01

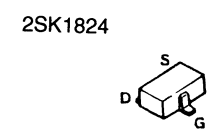
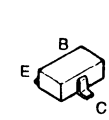
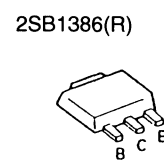
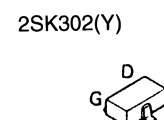
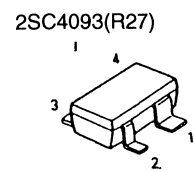
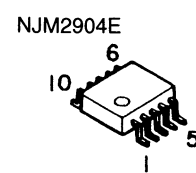
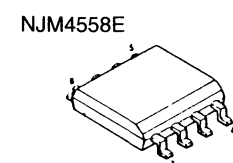
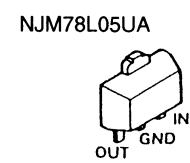
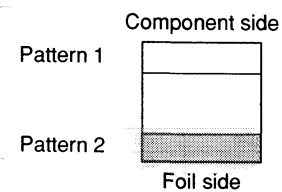



# PC BOARD VIEWS TKR-830

## TX UNIT(X56-3030-10)(A/3) (Component side) + (Foil side)

Ref. No.	Address	Ref. No.	Address	Ref. No.	Address	Ref. No.	Address
IC1	4Y	Q7	4I	Q201	7L	D202	6L
IC2	4L	Q8	8D	Q202	8L	D203	6L
IC3	10H	Q9	8D	Q203	8E	D205	9Q
IC4	10G	Q10	7D	Q205	9R	D206	6V
IC100	10H	Q11	7E	Q206	8P	D207	7V
IC101	7J	Q12	8E	Q240	8N	D240	6N
IC103	6Q	Q13	7C	Q241	8N		
IC105	10H	Q14	6C	D1	6H		
IC106	10E	Q15	8P	D2	6F		
IC108	4O	Q16	8D	D3	6H		
IC109	6I	Q17	8J	D4	6F		
IC110	9J	Q18	8I	D5	7H		
IC201	7K	Q102	10R	D6	7G		
IC202	7M	Q106	9R	D7	8C		
IC203	5J	Q107	8I	D8	7D		
IC204	9P	Q110	7Q	D10	8D		
IC205	7O	Q111	7Q	D11	7D		
Q1	7H	Q112	7Q	D12	7E		
Q2	7F	Q113	7Q	D101	8Q		
Q3	8H	Q114	7Q	D103	8Q		
Q4	8G	Q115	10O	D201	6L		
Q5	8G						
Q6	8G						

## TX-RX UNIT (X56-3030-10) (A/3) Component side + Foil side view

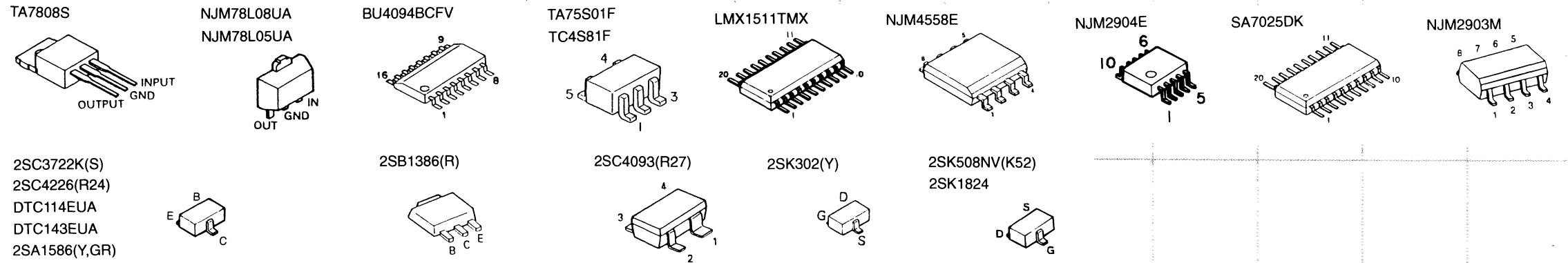
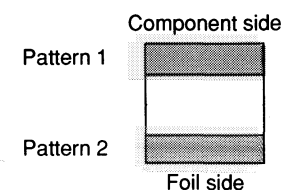
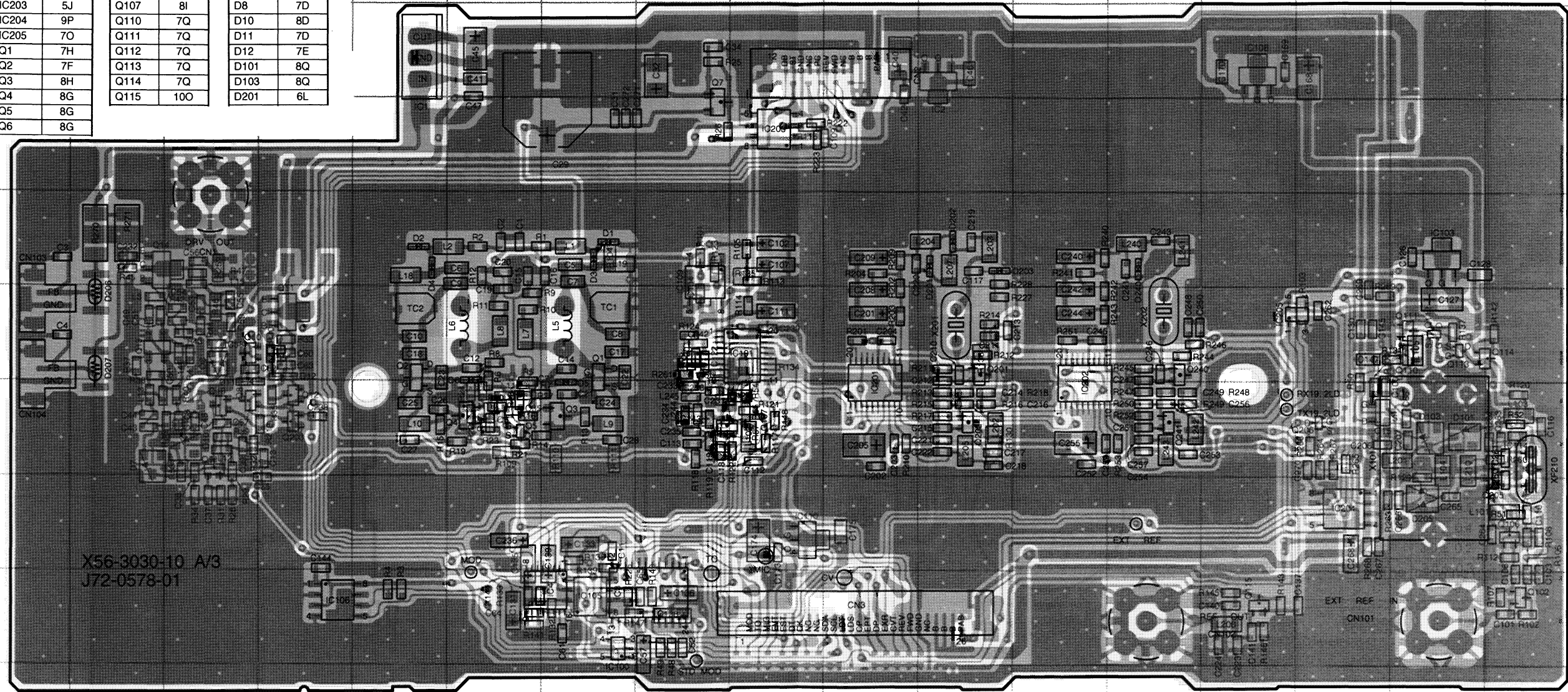



# TKR-830 PC BOARD VIEWS

## TX UNIT(X56-3030-10)(B/3) (Component side)

Ref. No.	Address
IC302	6J
IC303	6I
Q301	5M
Q302	10K
Q304	6K
Q305	7J
D301	5M
D302	10K
D303	10G
D304	6K
D305	7F
D310	9I
D311	9I

**TX-RX UNIT (X56-3030-10) (B/3) Component side view**

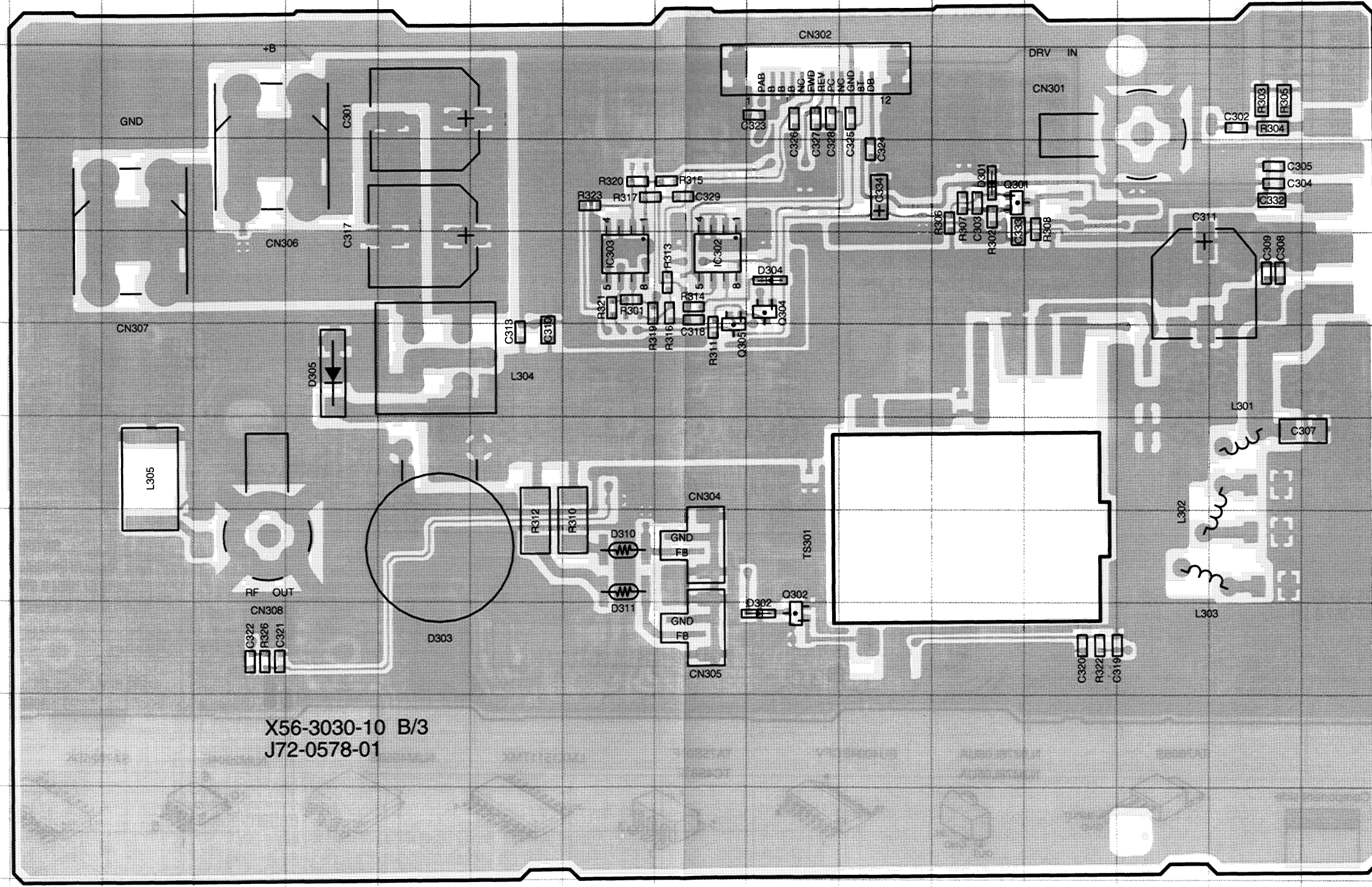

X56-3030-10 B/3  
J72-0578-01

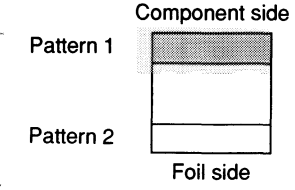
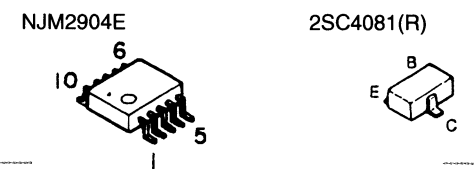



# PC BOARD VIEWS TKR-830

**TX-RX UNIT (X56-3030-10) (B/3) Foil side view**

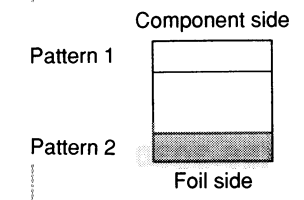

**TX UNIT(X56-3030-10)(B/3)  
(Foil side)**

Ref. No.	Address
D306	10E
D308	10C

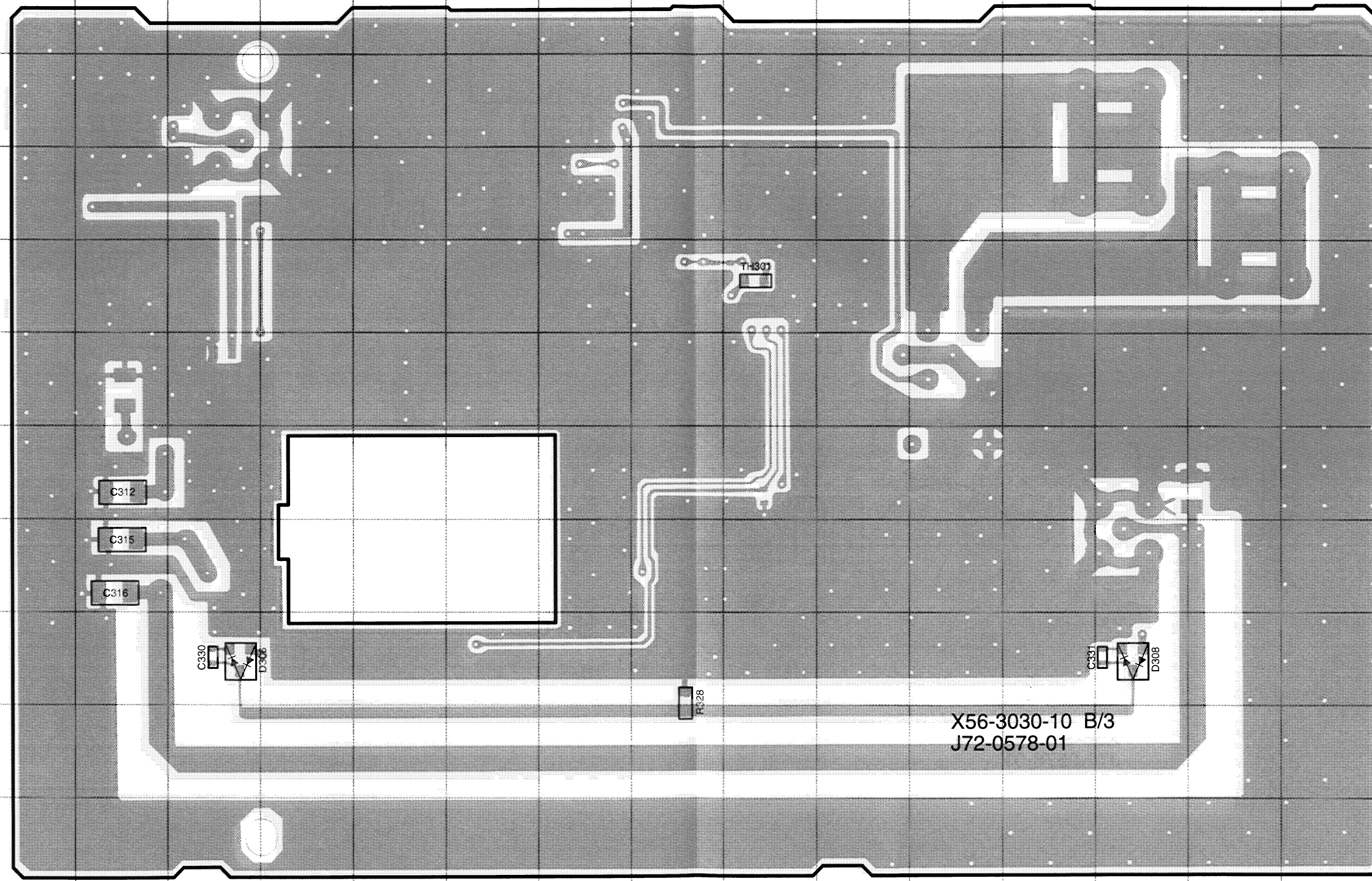

X56-3030-10 B/3  
J72-0578-01



# TKR-830 PC BOARD VIEWS

TX UNIT(X56-3030-10)(B/3)  
(Component side) + (Foil side)

Ref. No.	Address
IC302	6J
IC303	6I
Q301	5M
Q302	10K
Q303	10G
Q304	6K
Q305	7F
D301	5M
D302	10K
D303	10G
D304	6K
D305	7F
D306	10O
D308	10E
D310	9I
D311	9I

NJM2904E

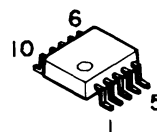

2SC4081(R)

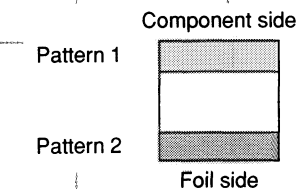

TX-RX UNIT (X56-3030-10) (B/3) Component side + Foil side view

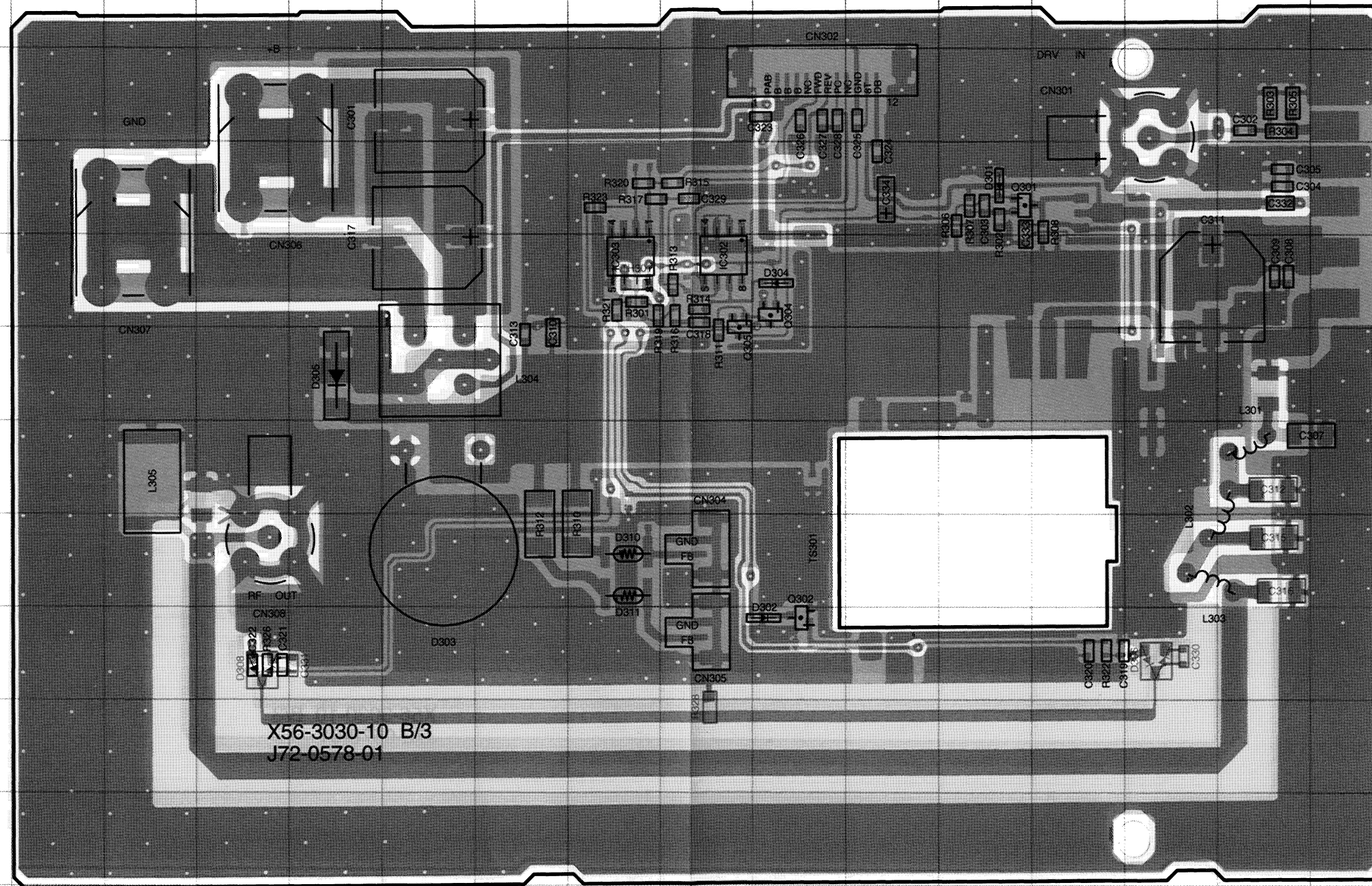

X56-3030-10 B/3  
J72-0578-01



# PC BOARD VIEWS TKR-830

**TX-RX UNIT (X56-3030-10) (C/3)**  
**Component side view**

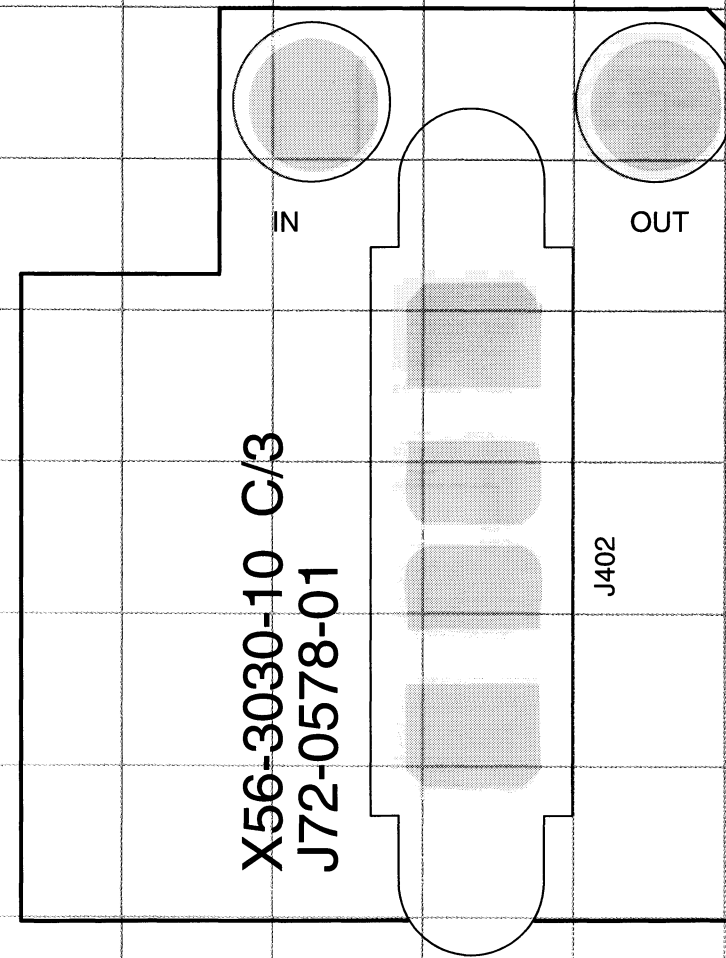

**TX-RX UNIT (X56-3030-10) (C/3)**  
**Foil side view**

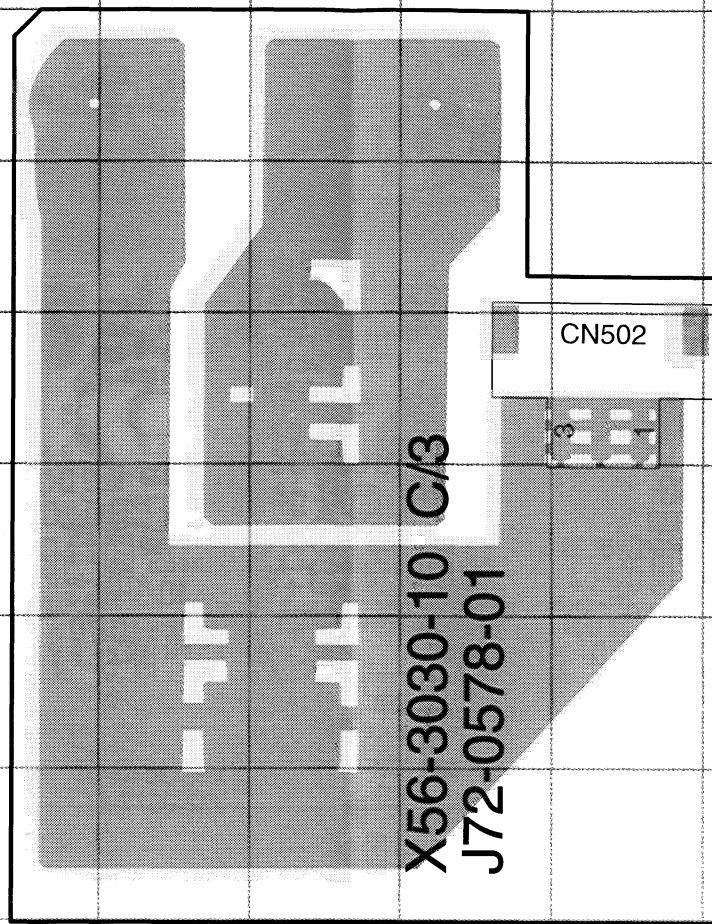

**TX-RX UNIT (X56-3030-10) (C/3)**  
**Component side + Foil side view**

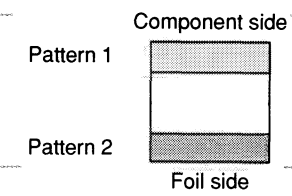
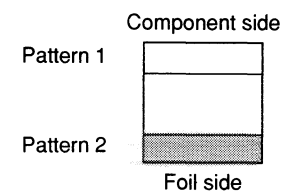
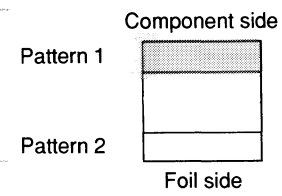
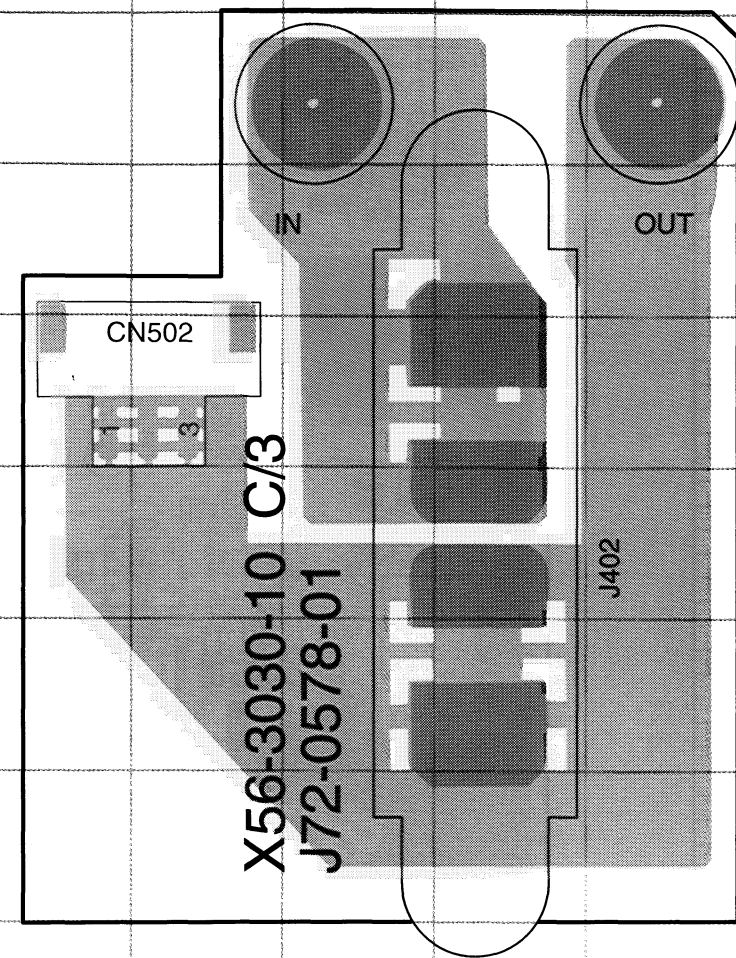

# TKR-830 PC BOARD VIEWS

**RX UNIT (X55-3040-10)**  
(Component side)

**RX UNIT (X55-3040-10) Component side view**

Ref. No.	Address
IC2	4K
IC3	4E
IC4	4D
IC5	7D
IC6	8D
IC7	8E
IC9	6E
IC13	4H
IC14	4M
IC17	5F
Q1	8J
Q3	7J
Q5	8J
Q6	7J
Q8	7L
Q9	7K
Q10	7M
Q12	7L
Q13	7M
Q14	8L
Q15	8H
Q16	6F
Q17	5O
Q18	6F
Q19	6F
Q20	6F
Q21	6H
Q22	5F
Q23	7H
Q26	3D
Q27	7G
Q28	3D
Q29	3D
Q30	10E
Q33	9F
Q34	7E
D2	6L
D3	6M
D4	6K
D6	6K
D9	6H
D11	4D

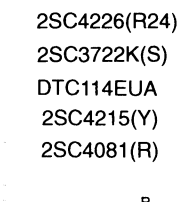
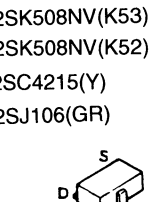
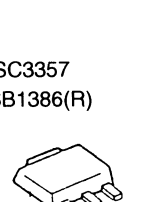
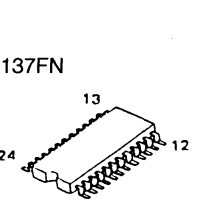
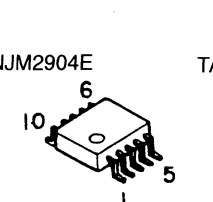
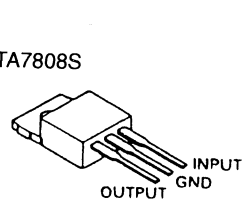
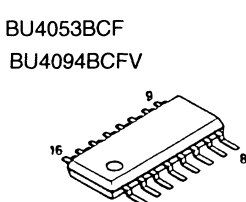
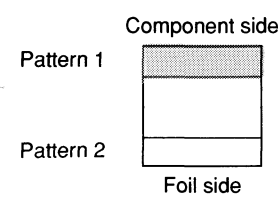
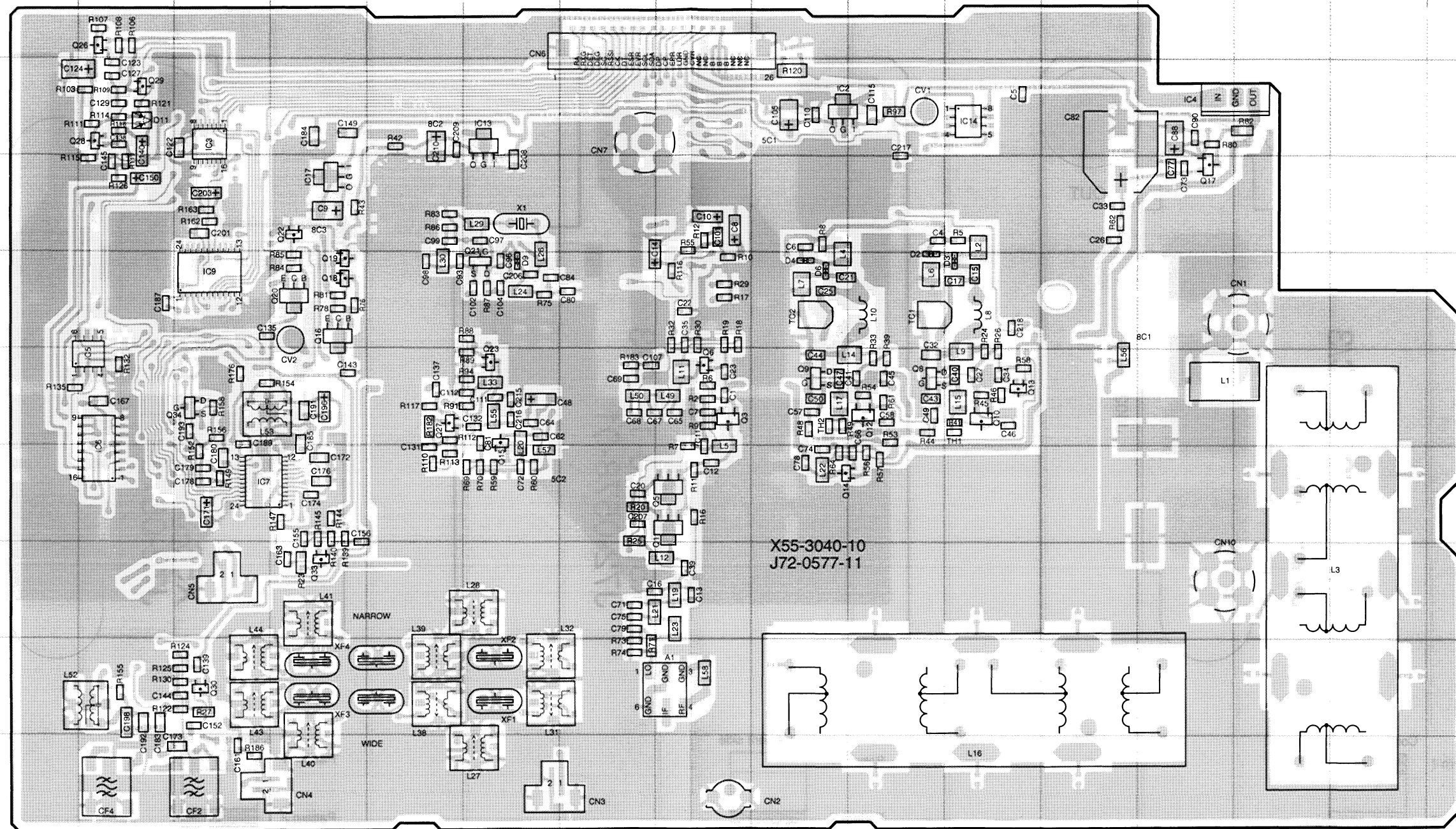



**RX UNIT(X55-3040-10)  
(Foil side)**

Ref. No.	Address
IC1	6K
IC8	10P
IC10	3K
IC11	7O
IC12	9Q
IC15	7L
IC16	8M
IC18	4J
IC19	4I
Q7	10E
Q24	11M
Q25	9M
Q31	11O
Q32	9O
Q35	9P
Q36	6Q
Q37	6P
Q38	6P
D1	6P
D10	10L

**RX UNIT (X56-3040-10) Foil side view**

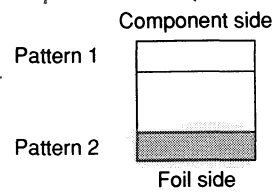
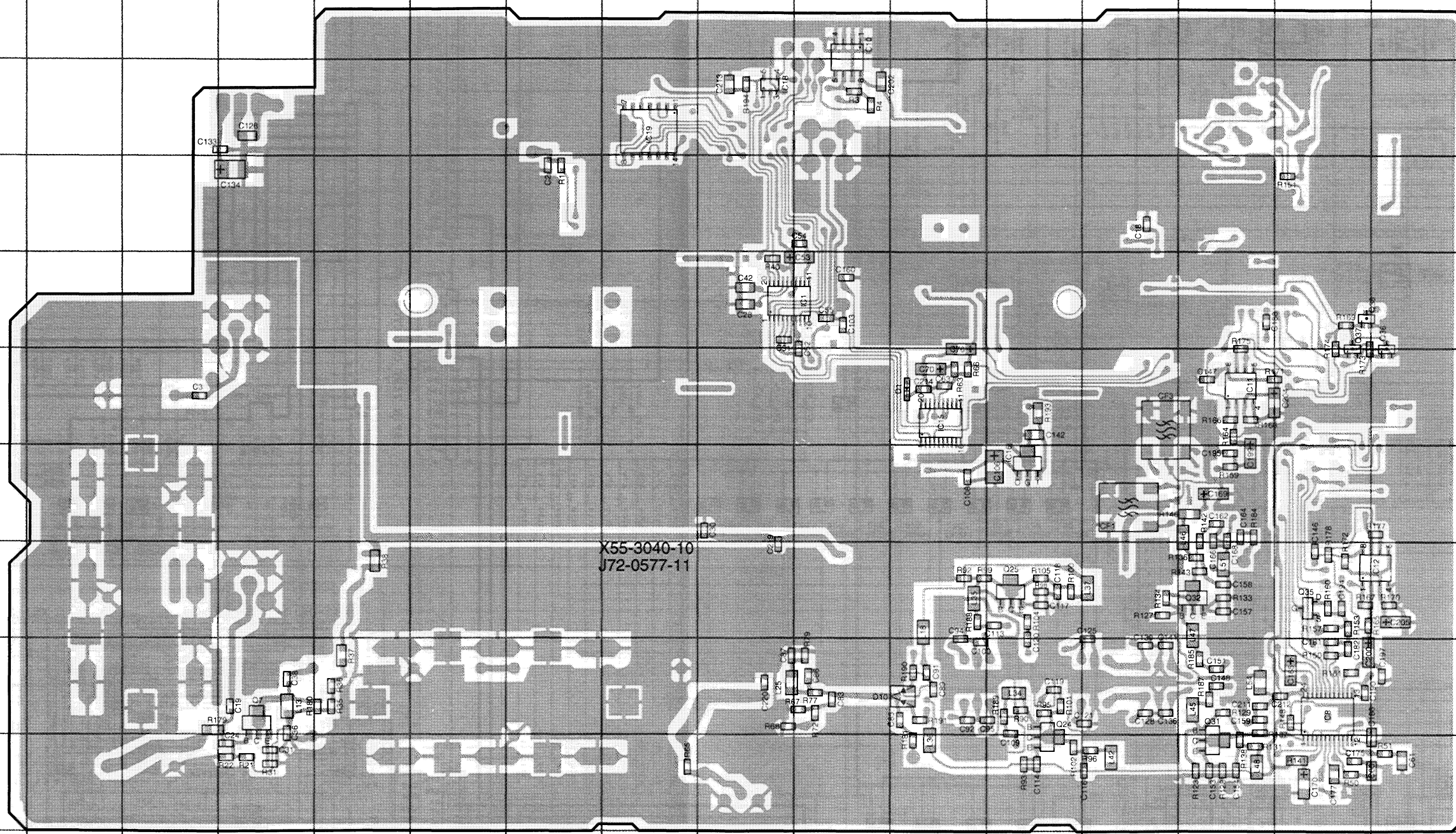

LMX1511TMX  
SA7025DK

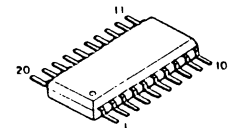

TA31137FN

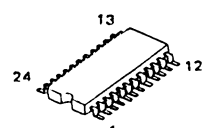

NJM4558E

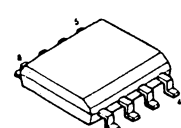

TC74HC14AF

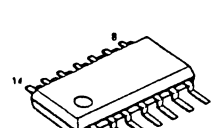

2SC3357

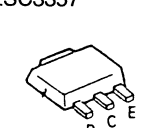

DTC114EUA

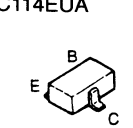

2SJ106(GR)

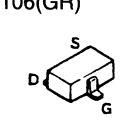



# PC BOARD VIEWS TKR-830

RX UNIT(X55-3040-10)  
(Component side) + (Foil side)

Ref. No.	Address
IC1	6AC
IC2	4AD
IC3	4X
IC4	4AH
IC5	7W
IC6	8W
IC7	8X
IC8	10W
IC9	6X
IC10	3AB
IC11	7X
IC12	9W
IC13	6AA
IC14	6AF
IC15	7AA
IC16	8Z
IC17	5Y
IC18	4AC
IC19	4AD
Q1	8AC
Q3	7AC
Q5	8AC
Q6	7AC
Q7	10AH
Q8	7AE
Q9	7AD
Q10	7AF
Q12	7AE
Q13	7AF
Q14	8AE
Q15	8AA
Q16	6Y
Q17	5AH
Q18	6Y
Q19	6Y
Q20	6Y
Q21	6AA
Q22	5Y
Q23	7AA
Q24	10Z
Q25	9Z
Q26	3W
Q27	7Z
Q28	3W
Q29	3W
Q30	10X
Q31	10X
Q32	9Y
Q33	9Y
Q34	7X
Q35	9W
Q36	6W
Q37	6W
Q38	6W
D1	6W
D2	6AE
D3	6AF
D4	6AD
D6	6AD
D9	6AA
D10	10AB
D11	4W

RX UNIT (X56-3040-10) Component side + Foil side view

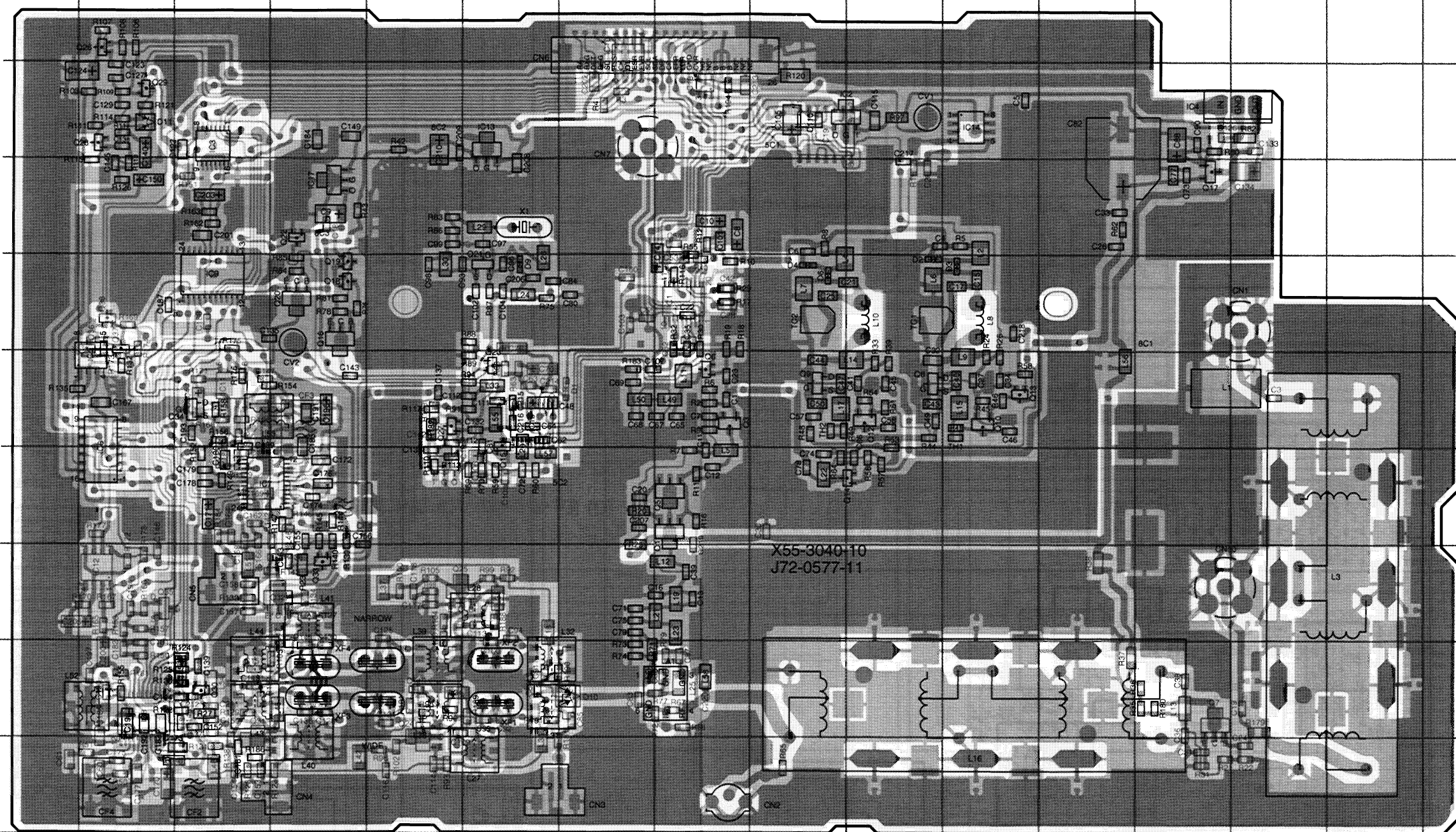

2SK508NV(K53)  
2SK508NV(K52)  
2SC4215(Y)  
2SJ106(GR)

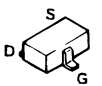

2SC3356  
2SC4226(R24)  
2SC3722K(S)  
DTC114EUA  
2SC4215(Y)  
2SC4081(R)

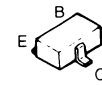

2SC3357  
2SB1386(R)

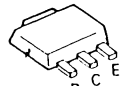

TC4S81F

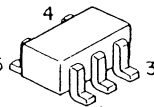

	LMX1511TMX SA7025DK	NJM78L08UA NJM78L05UA	BU4053BCF BU4094BCFV	TA7808S	NJM2904E	TA31137FN	NJM4558E	TC74HC14AF	
Pattern 1									
Pattern 2									

# R-830 SCHEMATIC DIAGRAM

X53-9810-10(A4) CONTROL UNIT

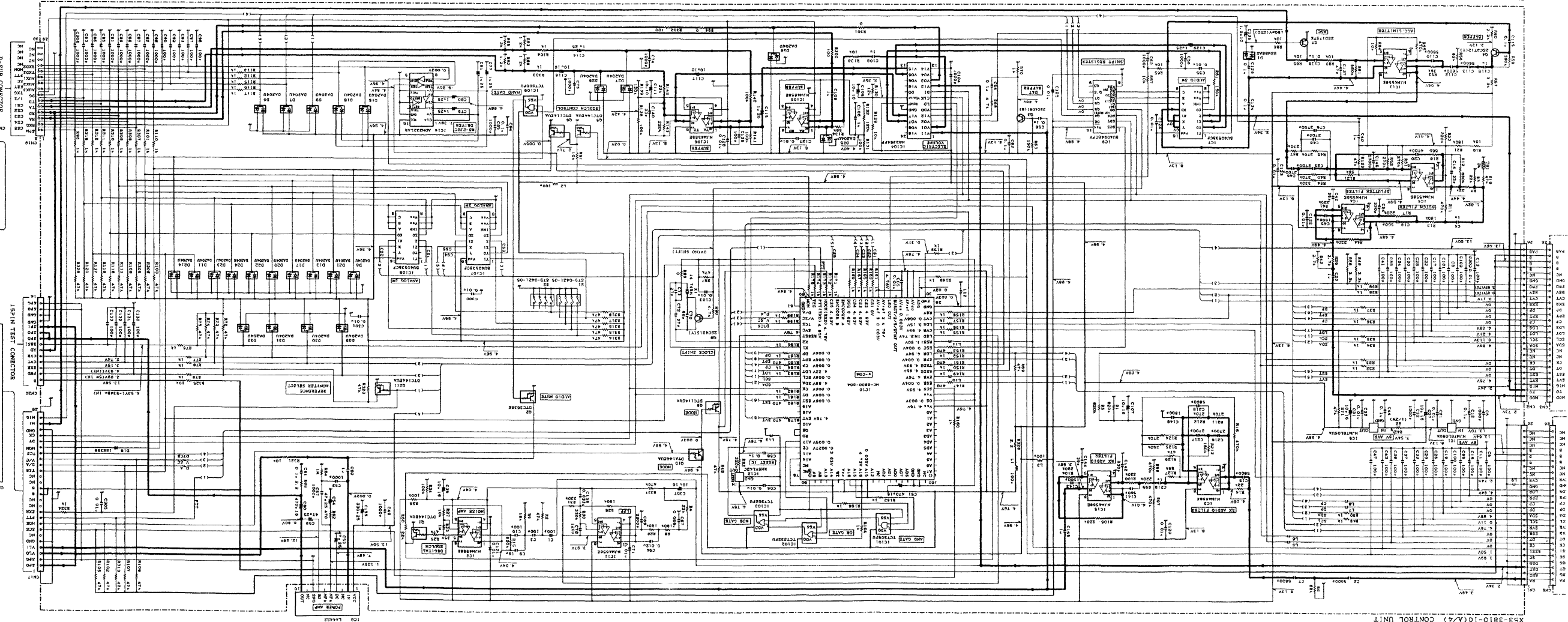

IC1 1K4422 IC2 1K4422 IC3 1K4422 IC4 1K4422 IC5 1K4422 IC6 1K4422 IC7 1K4422 IC8 1K4422 IC9 1K4422 IC10 1K4422 IC11 1K4422 IC12 1K4422 IC13 1K4422 IC14 1K4422 IC15 1K4422 IC16 1K4422 IC17 1K4422 IC18 1K4422 IC19 1K4422 IC20 1K4422 IC21 1K4422 IC22 1K4422 IC23 1K4422 IC24 1K4422 IC25 1K4422 IC26 1K4422 IC27 1K4422 IC28 1K4422 IC29 1K4422 IC30 1K4422 IC31 1K4422 IC32 1K4422 IC33 1K4422 IC34 1K4422 IC35 1K4422 IC36 1K4422 IC37 1K4422 IC38 1K4422 IC39 1K4422 IC40 1K4422 IC41 1K4422 IC42 1K4422 IC43 1K4422 IC44 1K4422 IC45 1K4422 IC46 1K4422 IC47 1K4422 IC48 1K4422 IC49 1K4422 IC50 1K4422 IC51 1K4422 IC52 1K4422 IC53 1K4422 IC54 1K4422 IC55 1K4422 IC56 1K4422 IC57 1K4422 IC58 1K4422 IC59 1K4422 IC60 1K4422 IC61 1K4422 IC62 1K4422 IC63 1K4422 IC64 1K4422 IC65 1K4422 IC66 1K4422 IC67 1K4422 IC68 1K4422 IC69 1K4422 IC70 1K4422 IC71 1K4422 IC72 1K4422 IC73 1K4422 IC74 1K4422 IC75 1K4422 IC76 1K4422 IC77 1K4422 IC78 1K4422 IC79 1K4422 IC80 1K4422 IC81 1K4422 IC82 1K4422 IC83 1K4422 IC84 1K4422 IC85 1K4422 IC86 1K4422 IC87 1K4422 IC88 1K4422 IC89 1K4422 IC90 1K4422 IC91 1K4422 IC92 1K4422 IC93 1K4422 IC94 1K4422 IC95 1K4422 IC96 1K4422 IC97 1K4422 IC98 1K4422 IC99 1K4422 IC100 1K4422

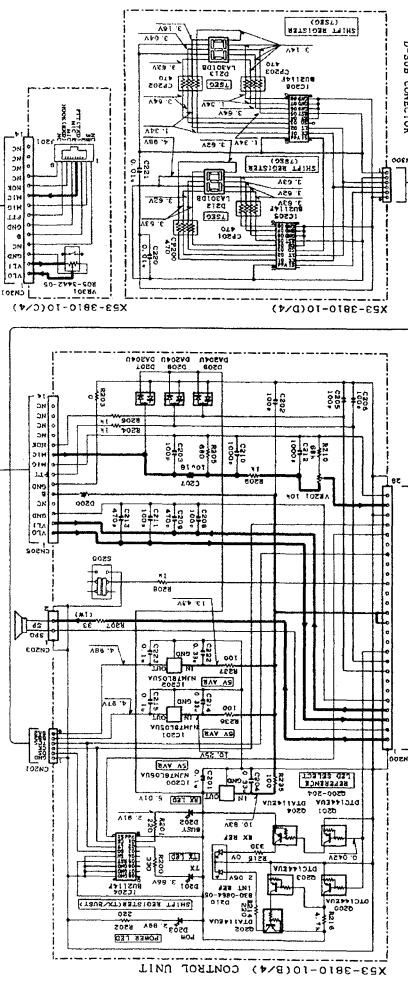

Note: Ref. No. Parts of pattern 1.

A B C D E F G H I J K L M N O P Q R S



**SCHMATIC DIAGRAM TKR-83**

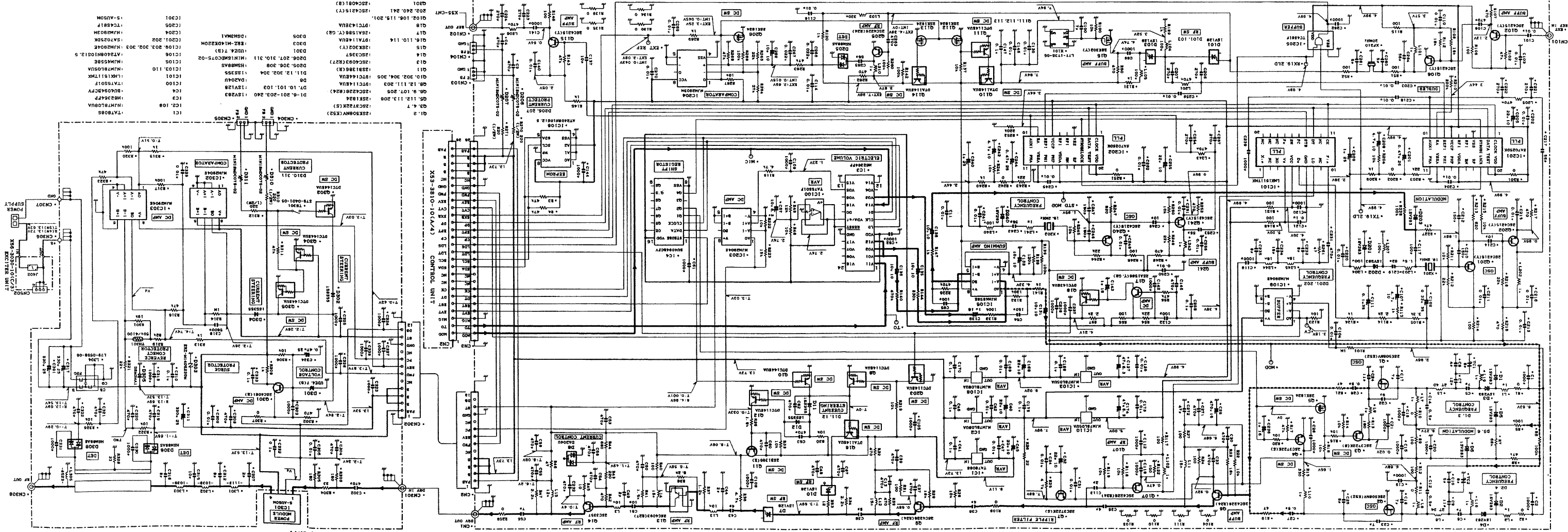

- D1-1 6X4
- D1-2 6X4
- D1-3 6X4
- D1-4 6X4
- D1-5 6X4
- D1-6 6X4
- D1-7 6X4
- D1-8 6X4
- D1-9 6X4
- D1-10 6X4
- D1-11 6X4
- D1-12 6X4
- R1-1 100K
- R1-2 100K
- R1-3 100K
- R1-4 100K
- R1-5 100K
- R1-6 100K
- R1-7 100K
- R1-8 100K
- R1-9 100K
- R1-10 100K
- R1-11 100K
- R1-12 100K
- R1-13 100K
- R1-14 100K
- R1-15 100K
- R1-16 100K
- R1-17 100K
- R1-18 100K
- R1-19 100K
- R1-20 100K
- R1-21 100K
- R1-22 100K
- R1-23 100K
- R1-24 100K
- R1-25 100K
- R1-26 100K
- R1-27 100K
- R1-28 100K
- R1-29 100K
- R1-30 100K
- R1-31 100K
- R1-32 100K
- R1-33 100K
- R1-34 100K
- R1-35 100K
- R1-36 100K
- R1-37 100K
- R1-38 100K
- R1-39 100K
- R1-40 100K
- R1-41 100K
- R1-42 100K
- R1-43 100K
- R1-44 100K
- R1-45 100K
- R1-46 100K
- R1-47 100K
- R1-48 100K
- R1-49 100K
- R1-50 100K
- R1-51 100K
- R1-52 100K
- R1-53 100K
- R1-54 100K
- R1-55 100K
- R1-56 100K
- R1-57 100K
- R1-58 100K
- R1-59 100K
- R1-60 100K
- R1-61 100K
- R1-62 100K
- R1-63 100K
- R1-64 100K
- R1-65 100K
- R1-66 100K
- R1-67 100K
- R1-68 100K
- R1-69 100K
- R1-70 100K
- R1-71 100K
- R1-72 100K
- R1-73 100K
- R1-74 100K
- R1-75 100K
- R1-76 100K
- R1-77 100K
- R1-78 100K
- R1-79 100K
- R1-80 100K
- R1-81 100K
- R1-82 100K
- R1-83 100K
- R1-84 100K
- R1-85 100K
- R1-86 100K
- R1-87 100K
- R1-88 100K
- R1-89 100K
- R1-90 100K
- R1-91 100K
- R1-92 100K
- R1-93 100K
- R1-94 100K
- R1-95 100K
- R1-96 100K
- R1-97 100K
- R1-98 100K
- R1-99 100K
- R1-100 100K
- C1-1 1000P
- C1-2 1000P
- C1-3 1000P
- C1-4 1000P
- C1-5 1000P
- C1-6 1000P
- C1-7 1000P
- C1-8 1000P
- C1-9 1000P
- C1-10 1000P
- C1-11 1000P
- C1-12 1000P
- C1-13 1000P
- C1-14 1000P
- C1-15 1000P
- C1-16 1000P
- C1-17 1000P
- C1-18 1000P
- C1-19 1000P
- C1-20 1000P
- C1-21 1000P
- C1-22 1000P
- C1-23 1000P
- C1-24 1000P
- C1-25 1000P
- C1-26 1000P
- C1-27 1000P
- C1-28 1000P
- C1-29 1000P
- C1-30 1000P
- C1-31 1000P
- C1-32 1000P
- C1-33 1000P
- C1-34 1000P
- C1-35 1000P
- C1-36 1000P
- C1-37 1000P
- C1-38 1000P
- C1-39 1000P
- C1-40 1000P
- C1-41 1000P
- C1-42 1000P
- C1-43 1000P
- C1-44 1000P
- C1-45 1000P
- C1-46 1000P
- C1-47 1000P
- C1-48 1000P
- C1-49 1000P
- C1-50 1000P
- C1-51 1000P
- C1-52 1000P
- C1-53 1000P
- C1-54 1000P
- C1-55 1000P
- C1-56 1000P
- C1-57 1000P
- C1-58 1000P
- C1-59 1000P
- C1-60 1000P
- C1-61 1000P
- C1-62 1000P
- C1-63 1000P
- C1-64 1000P
- C1-65 1000P
- C1-66 1000P
- C1-67 1000P
- C1-68 1000P
- C1-69 1000P
- C1-70 1000P
- C1-71 1000P
- C1-72 1000P
- C1-73 1000P
- C1-74 1000P
- C1-75 1000P
- C1-76 1000P
- C1-77 1000P
- C1-78 1000P
- C1-79 1000P
- C1-80 1000P
- C1-81 1000P
- C1-82 1000P
- C1-83 1000P
- C1-84 1000P
- C1-85 1000P
- C1-86 1000P
- C1-87 1000P
- C1-88 1000P
- C1-89 1000P
- C1-90 1000P
- C1-91 1000P
- C1-92 1000P
- C1-93 1000P
- C1-94 1000P
- C1-95 1000P
- C1-96 1000P
- C1-97 1000P
- C1-98 1000P
- C1-99 1000P
- C1-100 1000P

Note: Ref. No. : Parts of pattern 1.

# TKR-830 SCHEMATIC DIAGRAM

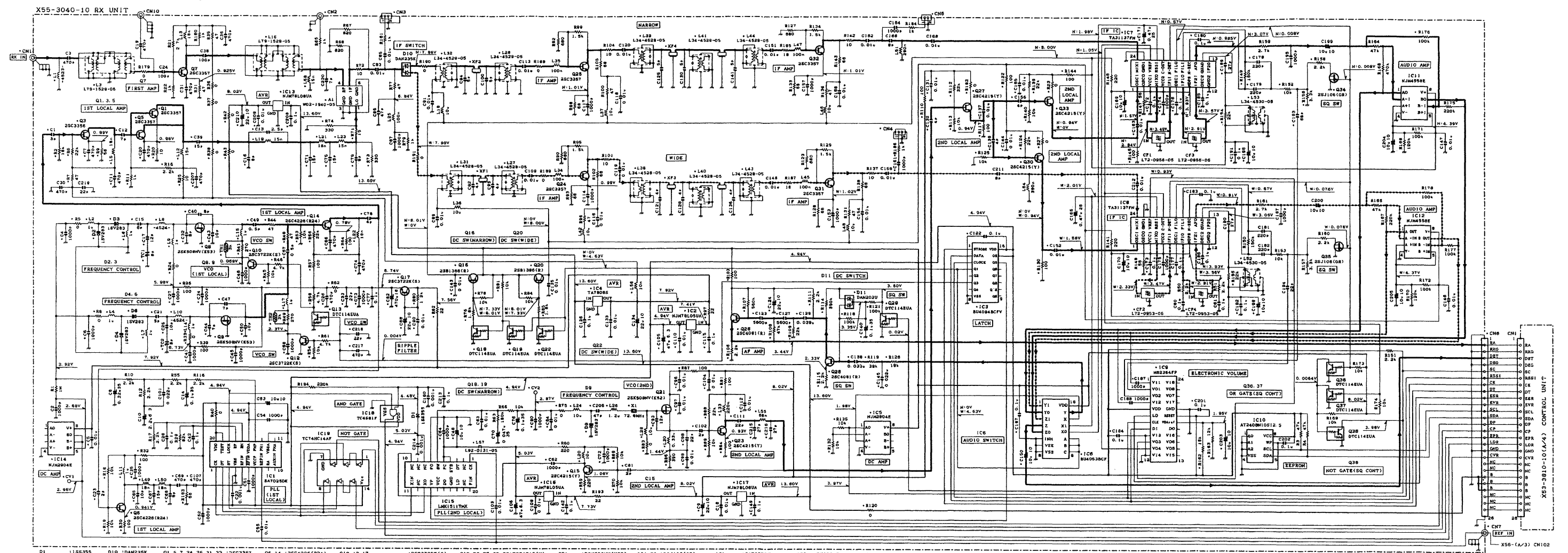

- |            |        |     |         |    |                      |         |        |               |                            |             |                     |            |         |              |         |            |     |            |     |            |         |           |        |           |          |                |          |            |      |           |
|------------|--------|-----|---------|----|----------------------|---------|--------|---------------|----------------------------|-------------|---------------------|------------|---------|--------------|---------|------------|-----|------------|-----|------------|---------|-----------|--------|-----------|----------|----------------|----------|------------|------|-----------|
| D1         | 188355 | D10 | DAN236X | Q1 | 5, 7, 24, 25, 31, 32 | 28C3357 | 06, 14 | 28C4226(R24)  | Q10, 12, 17                | 28C3722K(5) | Q15, 23, 27, 30, 33 | 28C4215(Y) | Q21     | 28K08NV(E52) | Q34, 35 | 28J106(GR) | IC1 | SAT025DK   | IC3 | BU4094BCPV | IC5, 14 | NJN2904E  | IC7, 8 | TA31137FN | IC10     | AT2408N10E12.5 | IC13, 17 | NJN19L08UA | IC18 | TC481P    |
| D2-4, 6, 9 | 18V283 | D11 | DAN202U | Q3 |                      | 28C3356 | 08, 9  | 28K508NV(E53) | Q13, 18, 19, 22, 29, 30-38 | DTC114EUA   | Q16, 20             | 28B1366(R) | Q26, 28 | 28C4081(E)   | Q38     | 28C4081(E) | IC2 | NJN19L08UA | IC4 | TA7808     | IC6     | BU4053BCF | IC8    | MB2364FP  | IC11, 12 | NJN4558E       | IC15     | LMX1511TX  | IC19 | TC74HC14P |

Note: Ref. No.: Parts of pattern 1.

# TKR-830 TKR-830 BLOCK DIAGRAM

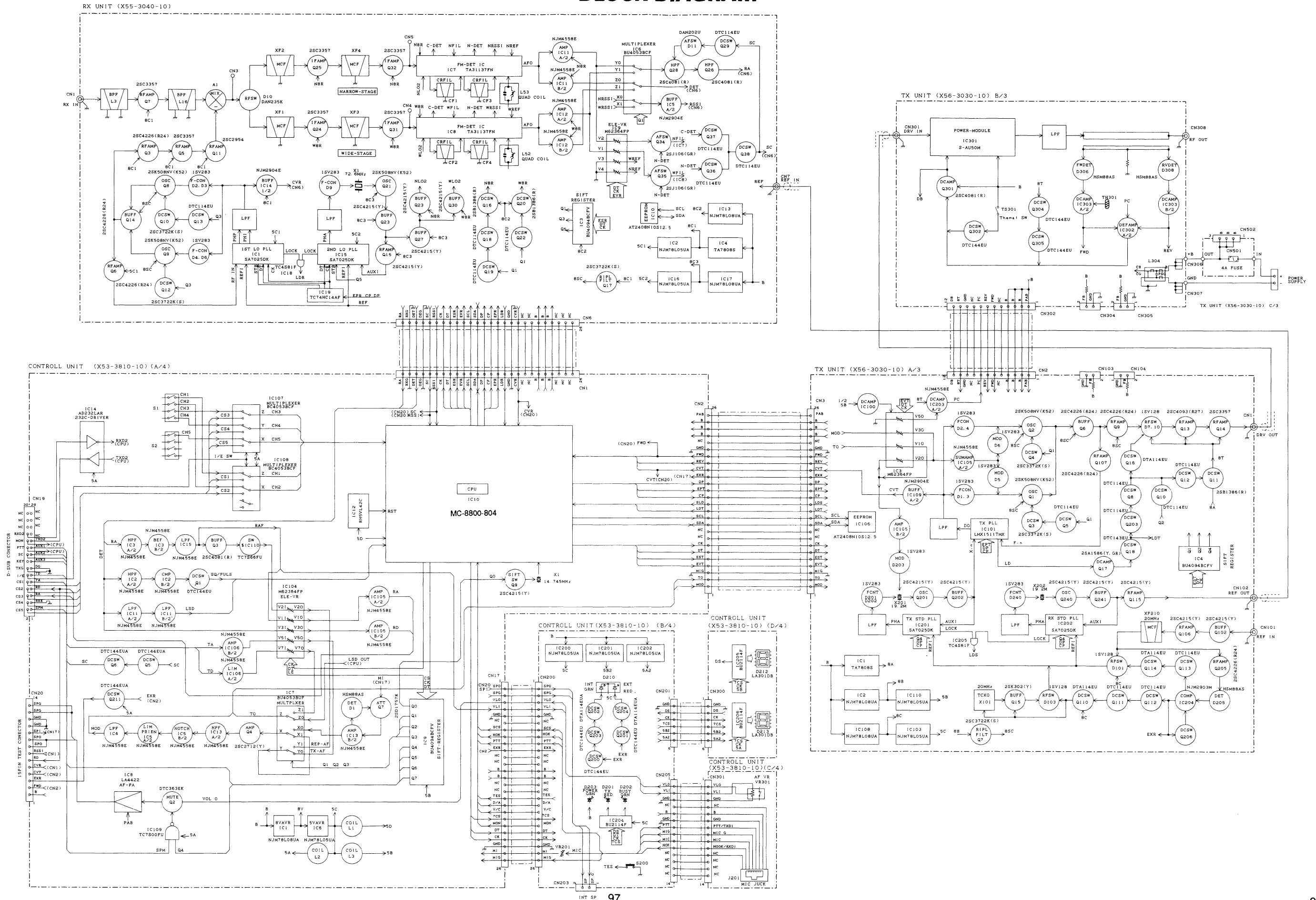

# TKR-830 TKR-830 LEVEL DIAGRAM

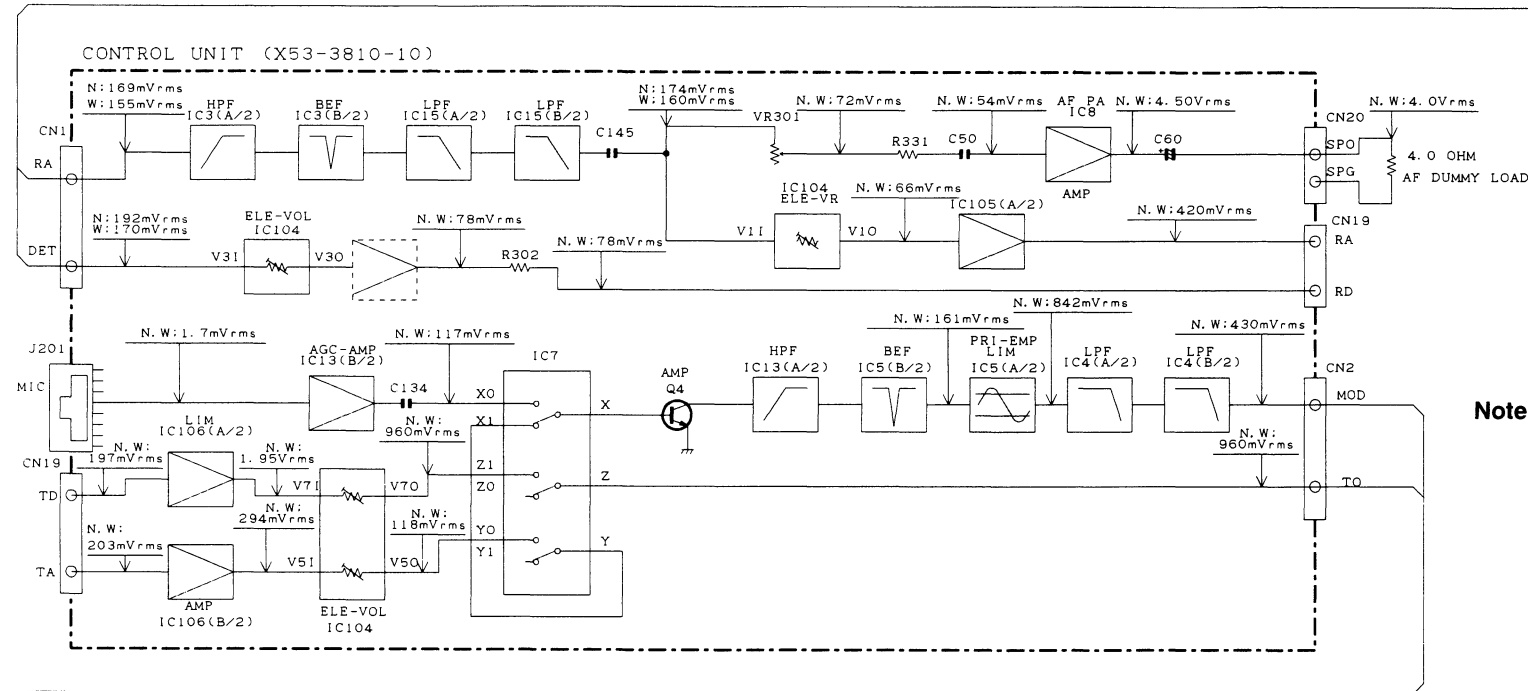
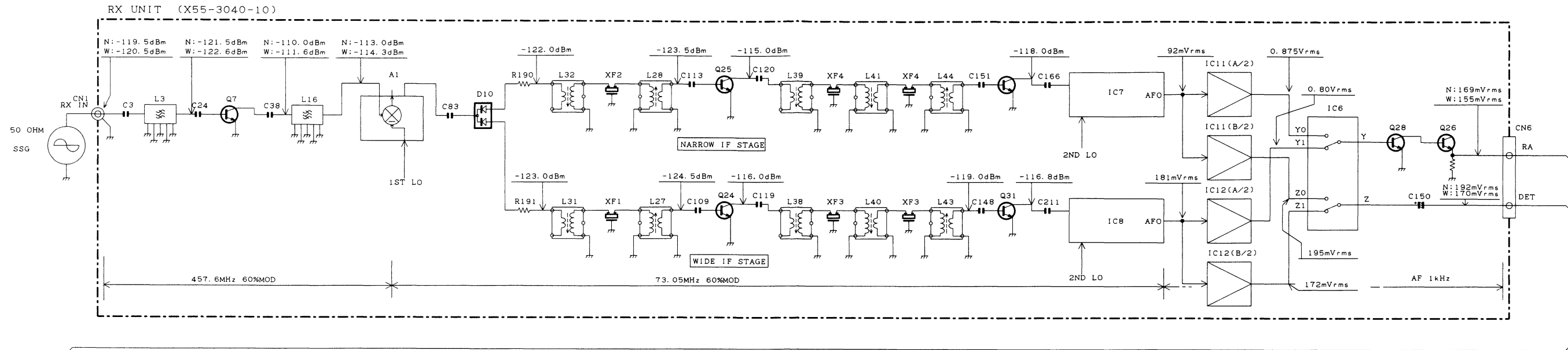

- Note**
- Because the speech output terminal reaches 12dB SINAD when receiving high frequencies, you need an antenna input level (60% modulation)
  - Even though the speech output terminal reaches 4W when receiving low frequencies, you need a 1kHz AF signal level.
  - Even though the modulation reaches 60% when transmitting low frequencies, you need a 1kHz MIC input level.
  - Measure the level of transmitted high frequencies directly from a special quality 50Ω impedance spectrum analyzer.

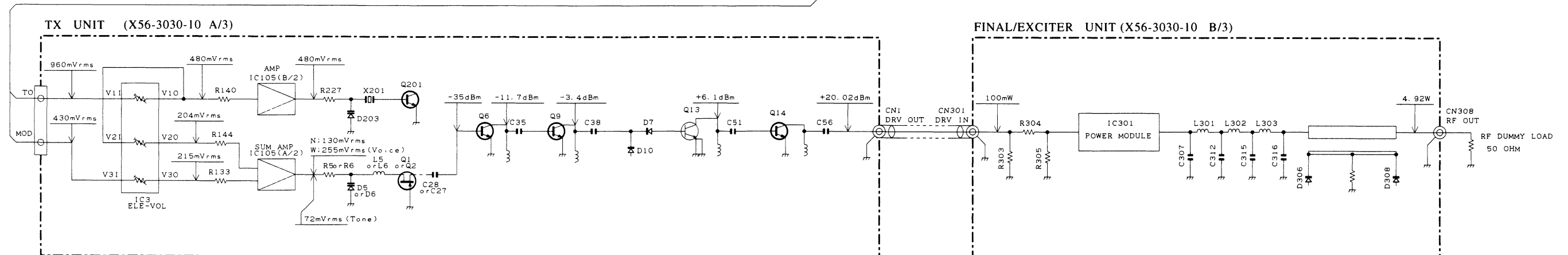

# TKR-830 TKR-830 INTERCONNECTION DIAGRAM

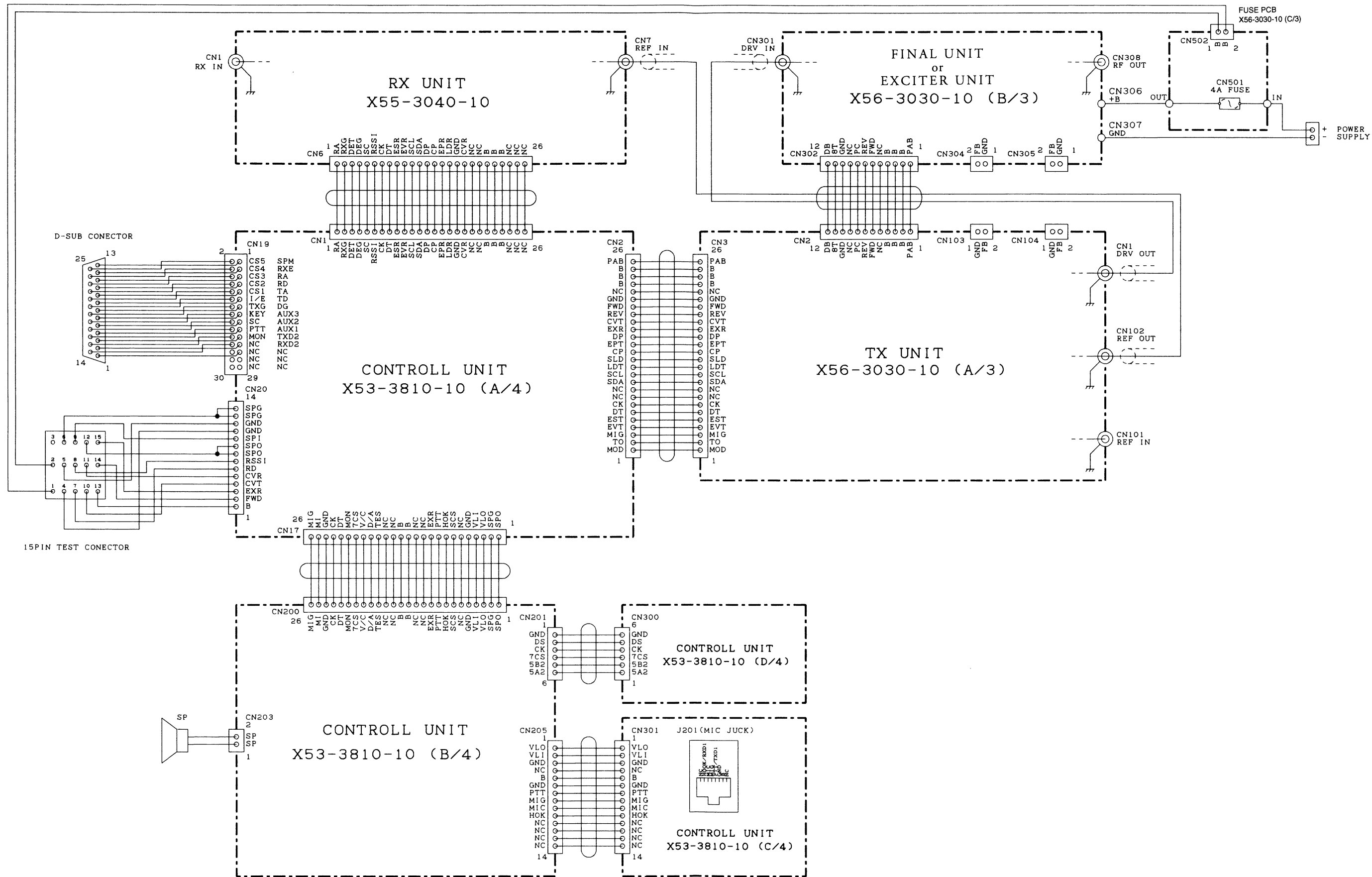



# TKR-830 KSP-1A/KES-4 (EXTERNAL SPEAKER)

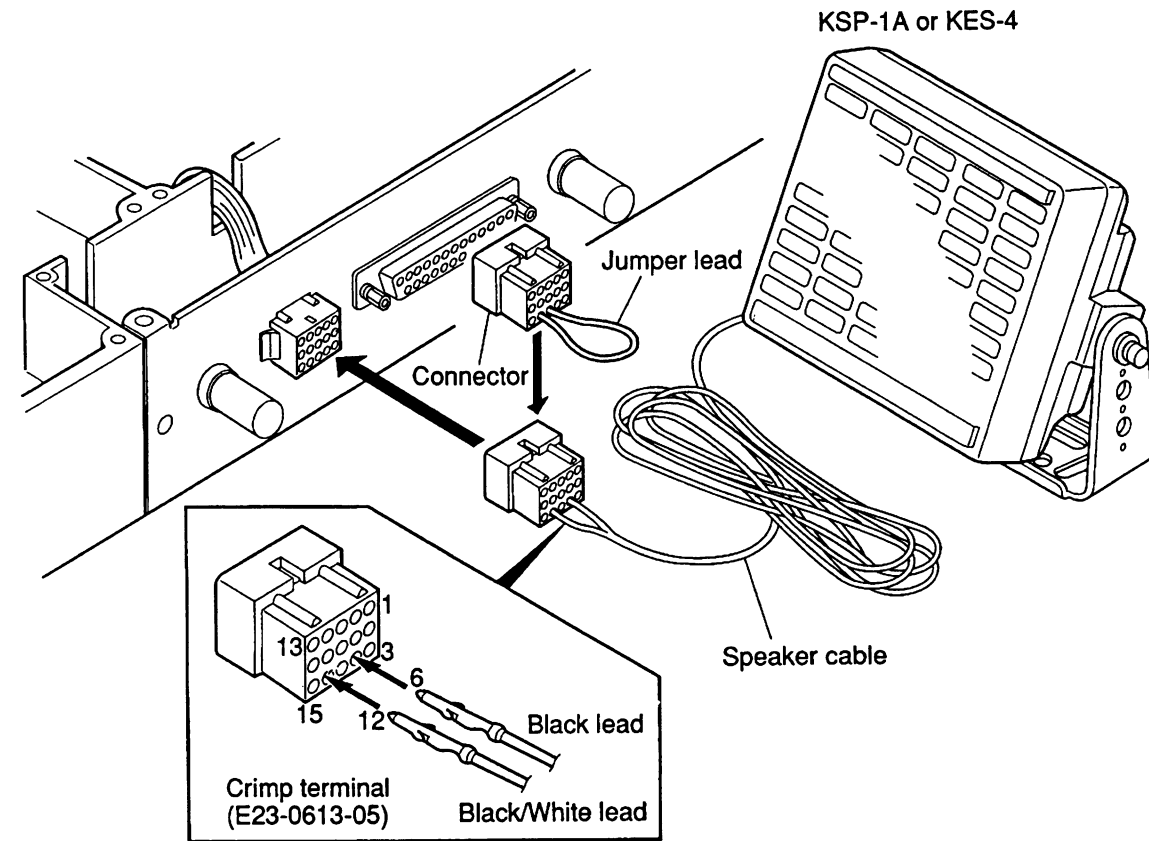

### ■ When using an external speaker :

1. Make sure the unit's power is turned OFF.
2. When using the external speaker, remove the jumper lead from the connector, and attach the speaker cable.

3. When not using the external speaker, replace the jumper lead and insert the connector into the speaker jack. (pins 9 and 12)

### ■ SPECIFICATIONS

Specifications	KES-4	KSP-1A
Speaker size	120 mm	120 mm
Maximum input power	20W	10W
Impedance	4 ohms	4 ohms
Frequency response	100 to 5000 Hz	165 to 8000Hz
Dimensions (W × H × D, projection not inclrd)	127 × 127 × 65mm (5" × 5" × 2-9/16")	127 × 127 × 65mm (5" × 5" × 2-9/16")
Weight	780g(1.72lbs)	750g(1.65lbs)a

# TKR-830 KPG-46 (PROGRAMMING INTERFACE CABLE)

KPG-46 External view

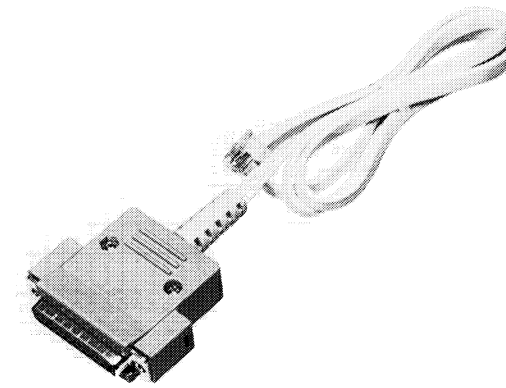



# TKR-830

## SPECIFICATIONS

### GENERAL

Frequency range .....	RX : 450,000 to 480,000 MHz, Band spread 5MHz TX : 450,000 to 480,000 MHz
Input volta .....	13.8V DC negative ground
Temperature range .....	-30°C to +60°C (-22°F to +140°F)
Frequency stability .....	±0.00015%
Antenna impedance .....	50Ω
Channel spacing .....	Wide : 25 kHz, Narrow : 12.5 kHz (PLL channel step 5 kHz, 6.25 kHz)
Channels quantity .....	1 (32 Preset)
Duty cycle .....	100%
Dimensions (not including protrusions) .....	19.00" (482.6mm) W × 1.73" (44mm) H × 10.41" (265mm) D

### RECEIVER

Sensitivity (EIA 12dB SINAD) .....	0.32 μV
Selectivity .....	Wide : -90dB, Narrow : -82dB
Channel Frequency Spread .....	5 MHz
Spurious and image rejection .....	-100 dB
Intermodulation .....	Wide : -85dB, Narrow : -80dB

### TRANSMITTER

RF power output .....	5W
Channel Frequency Spread .....	30MHz
Type of Emiss .....	11K0F3E, 16K0F3E
Audio distortion .....	Less than 2%
Spurious and emission .....	Harmonics : -50dB Short distance : -75dB
FM Noise .....	Wide : -55dB, Narrow : -50dB

## KENWOOD CORPORATION

14-6, Dogenzaka 1-chome, Shibuya-ku, Tokyo 150-8501, Japan

### KENWOOD SERVICE CORPORATION

P.O. BOX 22745, 2201 East Dominguez Street, Long Beach, CA 90801-5745, U.S.A.

### KENWOOD ELECTRONICS LATIN AMERICA S.A.

P.O. BOX 55-2791 Piso 6 Plaza Chase Cl, 47 y Aquilino de la Guardia Panama, Republic of Panama

### KENWOOD ELECTRONICS CANADA INC.

6070 Kestrel Road, Mississauga, Ontario, Canada L5T 1S8

### KENWOOD ELECTRONICS DEUTSCHLAND GMBH

Rembrücker Str. 15, 63150 Heusenstamm, Germany

### KENWOOD ELECTRONICS BELGIUM N.V.

Mechelsesteenweg 418 B-1930 Zaventem, Belgium

### KENWOOD ELECTRONICS FRANCE S.A.

13, Boulevard Ney, 75018 Paris, France

### KENWOOD ELECTRONICS U.K. LIMITED

KENWOOD House, Dwight Road, Watford, Herst., WD1 8EB United Kingdom

### KENWOOD ELECTRONICS EUROPE B.V.

Amsterdamseweg 37, 1422 AC Uithoorn, The Netherlands

### KENWOOD ELECTRONICS ITALIA S.p.A.

Via G. Sirtori, 7/9 20129 Milano, Italy

### KENWOOD IBERICA S.A.

Bolivia, 239-08020 Barcelona, Spain

### KENWOOD ELECTRONICS AUSTRALIA PTY. LTD.

(A.C.N. 001 499 074)

P.O. Box 504, 8 Figtree Drive, Australia Centre, Homebush, N.S.W. 2140, Australia

### KENWOOD ELECTRONICS (HONG KONG) LTD.

Unit 3712-3724, Level 37, Tower one Metroplaza, 223 Hing Fong Road, Kwai Fong, N.T., Hong Kong

### KENWOOD ELECTRONICS TECHNOLOGIES(S) PTE LTD.

Sales Marketing Division  
1 Ang Mo Kio Street 63, Singapore 569110