

Introduction



This manual provides technical information necessary for servicing the VXR-5000 FM Land Mobile Repeater. A reprint of the CE-8 channel-programming software manual is also included for easy reference.

Servicing this equipment requires expertise in handling surface-mount chip components. Attempts by non-qualified persons to service this equipment may result in permanent damage not covered by the warranty, and may be illegal in some countries.

Two PCB layout diagrams are provided for each double-sided circuit board in the repeater. Each side of the board is referred to by

the type of the majority of components installed on that side ("leaded" or "chip-only"). In most cases one side has only chip components, and the other has either a mixture of both chip and leaded components (trimmers, coils, electrolytic capacitors, ICs, etc.), or leaded components only.

While we believe the technical information in this manual to be correct, Yaesu Musen assumes no liability for damage that may occur as a result of typographical or other errors that may be present. Your cooperation in pointing out any inconsistencies in the technical information would be appreciated.

Repeater Version Identification

The VXR-5000 version can be determined from the identification label located on the rear panel. From the production code on the identification label, use the table below to determine the various hardware, options and operational features for which the repeater is configured, based on the example at the bottom of the table.

VXR-5000 Production Codes

Frequency Range	
13	134 - 147 MHz version A
14	146 - 160 MHz version B
15	156 - 168 MHz version BS-1
16	164 - 175 MHz version C
40	400 - 420 MHz version A
43	430 - 450 MHz version C
45	450 - 470 MHz version D
47	470 - 490 MHz version E
49	490 - 512 MHz version F
Channel Separation	
E	12.5 kHz
G	20 kHz
H	25 / 30 kHz
Power Output	
25	25 Watts RF Output
Not Used	
9	This digit not used (placeholder)
Control Units	
J	Standard Type
Options	
0	w / o Options
1	FTS-22 CTCSS Encoder/Decoder
AC Mains Voltage/AC Plug	
B	117 VAC 2P USA Plug w/o ground
C	117 VAC 3P USA Plug w/ground
E	220 VAC 2P USA Plug w/o ground
F	220 VAC 3P Europe Plug
G	234 VAC 3P Europe Plug
H	234 VAC 3P Australia Plug
L	220 VAC 3P Australia Plug
Z	12 VDC w/o AC Power Supply
Remarks	
A	without Special Instructions
X	with Special Instructions

VXR5000 15 E 25 9 J - 1 C

↑ This is an example of a typical Production Code and its meaning.

Specifications

General

Freq. Range (MHz):	Vers (A) 134 - 147 (B) 146 - 160 (BS1) 156 - 168 (C) 164 - 175
Max. Ch. Spread:	2 MHz (w/o degradation)
No. of Channels:	1 - 8
Ch. Separation:	12.5 kHz / 20 kHz / 25 kHz
Frequency Stability:	± 2 ppm
Emission Type:	F3E
Tx Activation System:	carrier-operated, CTCSS tone operated, or remote control
Power Requirements:	100/117/220/234 V AC (50/60 Hz), 13.8 VDC
Input Power:	200 W AC (25 watts RF output), 30 W standby 6.0 A DC (25 watts RF output), 500 mA standby
Operating Temp.:	-30 ~ +60 C
Case Size:	375 x 275 x 110 mm (WHD)
Weight:	12 kg

Transmitter

RF Power Output:	25 Watts, continuous-duty
Maximum Deviation:	± 2.5 kHz (12.5 kHz spacing) ± 4.0 kHz (20 kHz spacing) ± 5.0 kHz (25 kHz spacing)
Audio Response:	+ 6 dB/octave (+1.0/-3.0 dB)
Audio Distortion:	<5 %
FM Noise Ratio:	40dB
Spurious Emissions:	-80 dBc

Receiver

Receiver Type:	Double-conversion, Superheterodyne
Sensitivity:	0.5 μ V (0 dB μ) for 12 dB SINAD
1st & 2nd IF:	21.6 MHz (1st I.F.) 455 kHz (2nd I.F.)
Adj. Ch. Selectivity:	70 dB
Intermodulation:	70 dB
Spurious Response:	75 dB
AF Response:	750 μ s de-emphasis

Interface

Line Port:	600- Ω 4-wire (E+M signaling)
Accessory Port:	25-pin (DB-25F type)

Specifications subject to change without notice or obligation.

VXR-5000 Options & Accessories

<u>Model No.</u>	<u>Item</u>	<u>P/N</u>
YH-2	Intercom Headset w/Boom Microphone	D3000319
VTS-100	VX-TRUNK Unit	A06150001
MR-KIT 1	19" Cabinet Rack-Mount Unit	A06500001
PD-506	VHF Cavity Duplexer Unit	D3000275
VPL-1	Programming Connection Cable	
CE-8	Software Programming Disk	
FS-100	DC Local Controller with Line Interface Unit	A07410001

Rear Panel Controls & Connectors

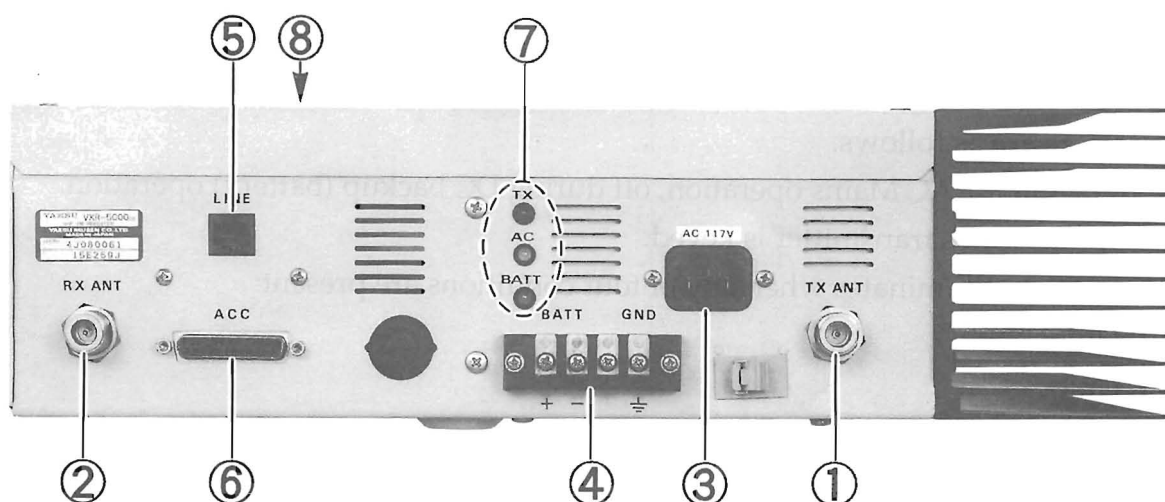

1. TX ANT

This N-type coaxial jack provides the transmitter output signal for connection to the transmitting antenna, or TX jack on the duplexer, if used. Impedance requirement is 50Ω.

2. RX ANT

This N-type coaxial jack accepts the receiver input signal from the receiving antenna or RX jack on the duplexer, if used. Impedance requirement is 50Ω.

3. AC

This receptacle accepts the AC power cord, which should be connected to the AC Mains supply or wall outlet. The AC line voltage must match that for which the repeater is wired.

4. BATT terminal posts

The terminal posts accept 12~15-V DC for operating the repeater from a battery or other DC source. When operating from AC mains, a small trickle current is present at these terminals to maintain battery charge. A battery rated for 12 volts, 55 Ah (minimum) is recommended for short-term emergency/backup operation.

5. LINE

This 8-pin modular jack is used for remote control and provides TX & RX audio, TX keying and squelch status output. Impedance is 600Ω.

6. ACC

This DB-25 connector provides a data interface between the microprocessor in the VXR-5000 and peripheral devices (such as the VTS-100 VX-TRUNK unit).

7. LED Indicators

TX - This LED glows red when transmitting.

AC - This LED glows green during AC operation.

BATT - This LED glows orange during DC operation.

8. Programming Jack (inside cabinet)

This 8-pin modular-type jack is located inside the repeater cabinet on top of the CNTL unit. The modular plug from the VPL-1 Cable or FRB-2 Service Kit cable is inserted here for channel programming using the CE-8 channel editor software, and an IBM PC®/PC-compatible personal computer with RS-232 serial port.

CNTL-1 Unit Status LEDs:

Three LED status indicators on the CNTL-1 Unit provide for visual monitoring of repeater operation while performing servicing and alignment. The repeater cabinet cover must be removed to view these.

LED indicators are as follows:

AC (D1002) - On for AC Mains operation, off during DC backup (battery) operation.

TX (D1008) - Indicates transmitter is keyed.

ALARM (D1001) - Illuminates when any of four conditions are present:

Rx PLL Unlock*

Tx PLL Unlock*

PA Module Hi Temp (PWR Reduction)*

EEPROM Data Error

**indicates parameter can also be monitored using the CE-8 Programming Software (see the EEPROM Programming Software Instructions chapter for details).*

Installation

Repeater operation without a duplexer requires that two antennas be installed, one for receiving and one for transmitting, so that the receiving antenna does not absorb energy from the transmitting antenna. There are a number of ways to do this, depending on the TX/RX frequency separation, and on the location available for antenna mounting. If a duplexer is used, a single antenna suffices for both transmitting and receiving. If using a reduced-size duplexer, a six-cavity model (minimum) is recommended.

Regardless of the above choice, it is of paramount importance that the antenna(s) be mounted as high as possible, and in the clear as possible, preferably within line-of-sight to all repeater users. Furthermore, losses in the feedline(s) must be minimized, so the feedline(s) should be high quality, and as short as possible. If a long feedline is necessary, use coaxial hardline cable to reduce losses.

Repeater antennas should have an impedance of 50 ohms at the operating frequency. When separate receive and transmit antennas are used, high-Q narrow-band types may serve to minimize interaction. However, when a single antenna is used with a duplexer, it should be a low-Q wide-band type.

NEVER TRANSMIT WITHOUT HAVING A TRANSMIT ANTENNA CONNECTED TO THE REPEATER.

AC Power Supply Voltage Selection

Each repeater is wired for a particular AC mains voltage between 100 and 234 VAC. This should be indicated by a label near the AC jack on the rear panel. If no label is present, or if the AC voltage on the label is different from the local AC line, check the wiring to the power transformer inside the repeater, and change the connections (and label) if necessary, as shown on the following page.

Changing the transformer wiring also requires changing the fuse in the power supply if the voltage is changed from below 117-V AC to above 200 VAC, or vice-versa. Use a

5-amp fuse for for 117 VAC or less, or a 3-amp fuse for 200 VAC or more.

Operation

DC Power Supply Backup

For uninterrupted operation during power failures, a 12-volt rechargeable type battery (55-Ah or more recommended) may be connected to the DC terminal posts on the rear panel. While the repeater is operating from the AC source, a slight charging current will maintain battery charge. In the event of AC power outage, the automatic power control circuit will automatically switch the repeater to the backup battery, and operation will not be interrupted.

After prolonged operation from the battery, it should be disconnected from the repeater and recharged separately before re-connecting, as the trickle charge is not sufficient for recharging a completely discharged battery. *Never reapply AC power to the repeater with a discharged battery connected, as the DC startup current can damage the repeater and battery.* While operating from a battery or DC supply, the repeater requires approximately 7 amperes at 12 volts during transmit.

Equipment Location

While the operating temperature range of the repeater is quite broad, the best location is still one in which the air temperature does not approach the extremes or change rapidly. Make sure to allow for free air circulation around the heatsink on the rear apron at all times. In warm climates, the repeater should not be sealed in a small closed room.

Protect the repeater from wind and rain, and extremes in temperature or humidity that may shorten the useful life of the equipment. Try to locate the repeater in an environment that is also comfortable for service personnel, if possible.

Changing Power Transformer AC Mains Wiring

Before attempting this wiring change, remove the AC power cord from the rear panel jack.

- ❑ Remove the four screws affixing the top cover of the repeater, and remove the cover.
- ❑ Note the location of the AC fuse, and the three screws affixing the clear protective plastic sheet to the repeater (one screw near the fuse block, and two on the PA Unit).
- ❑ Remove the four screws and the plastic sheet.

- ❑ Referring to the diagram below, determine the correct transformer primary jumper wiring for the AC Mains voltage used in your area.
- ❑ Next, using a medium power (approx. 30-watt) soldering iron, rewire the jumpers according to the diagram.
- ❑ If necessary, replace the AC fuse according to the AC Mains voltage range:
 - 100~117-V AC: 5A
 - 200~234-V AC: 3A
- ❑ Replace the clear protective sheet and cover, this completes the wiring change.

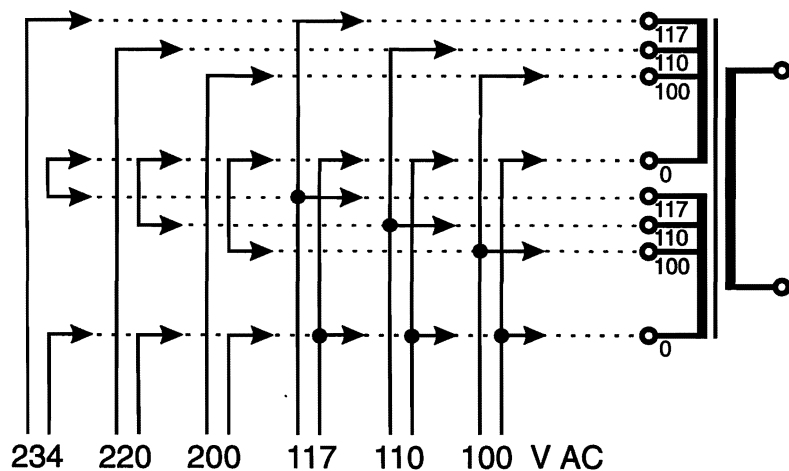

AC Mains Voltage Selection

Important!

If you change the AC voltage range, *you must also change the rear-panel AC fuse*. Do not replace with a slow-blow type fuse. Also make sure the voltage marking on the rear-panel label matches the new voltage setting.

Caution!

To avoid blowing the rear-panel AC fuse, wait at least 30 seconds after un-plugging the repeater AC power cord before plugging it in again. This allows the DC power supply capacitor-bank residual voltage to bleed down, and prevent a high start-up current when power is reapplied.

Repeater Mounting & Installation

Rack Mount

The optional MR-KIT 1 bracket kit is required for installation into an EIA-standard 19-inch rack. When stacking multiple VXR-5000 units in a rack, use forced air cooling. In addition, repeater output power should be reduced by approximately 50% when continuous duty operation is expected.

- ❑ To install the repeater, first remove the top cover and locate the three mounting holes.

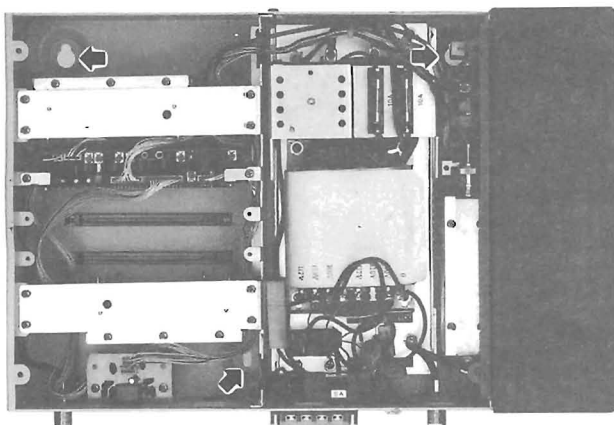

- ❑ Attach the VXR-5000 to the mounting cradle using the three supplied screws, then replace the protective sheet and top cover.
- ❑ Next, install the cradle front panel using three machine screws along the panel bottom, and one rack mount handle (two screws each) on each side.
- ❑ Insert the unit into the rack cabinet and secure it with four screws.

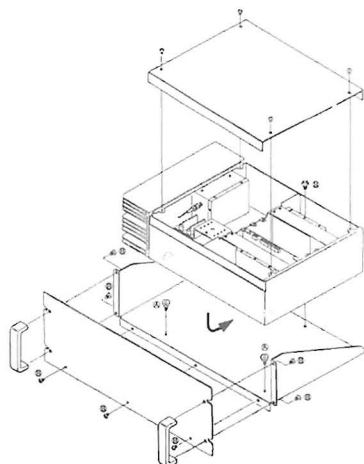

Wall Mount

The repeater can be affixed vertically to a wall using the three mounting holes in the bottom panel of the repeater chassis.

- ❑ Remove the top cover of the repeater and clear protective sheet, then locate the three mounting holes.
- ❑ Lay the repeater flat on a large sheet of paper or cardboard, and trace the outline of the mounting holes onto the paper to make a drilling template.

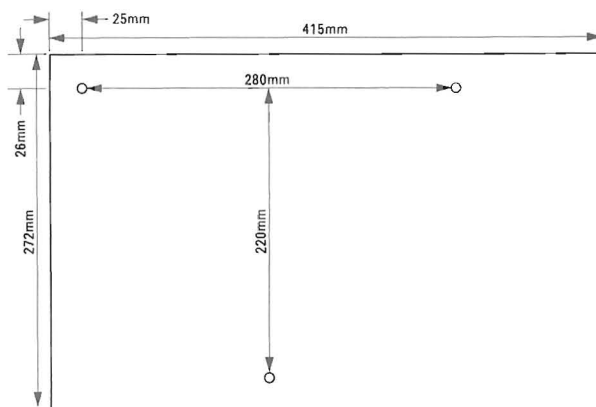

- ❑ Drive three large screws (not supplied) into the wall studs (anchor bolts can be used for concrete walls), leaving approximately 1 cm of the screw exposed.
- ❑ After aligning the repeater chassis mounting holes with the three exposed screws (or anchor bolts), hang the repeater in place, then drive the screws home to securely attach the repeater (see below).

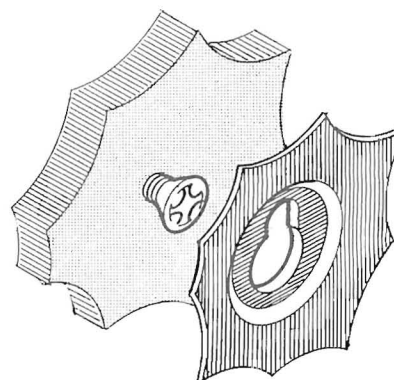

Notes:

VTS-100 VX-TRUNK I Interconnection

The VTS-100 VX-TRUNK I rack-mount unit is used with the VXR-5000 as part of a land-mobile trunking system. The VTS-100 connects to the repeater using the DB-25 connector (**ACC**). Interconnection requires a cable constructed according to the diagram below.

For VTS-100 operation, free the CNTL Unit card from the chassis as described later under *Cover Removal and Unit Access*, then slide switch S2001 on CNTL Unit 2 to the **HI** position, as shown at the right.

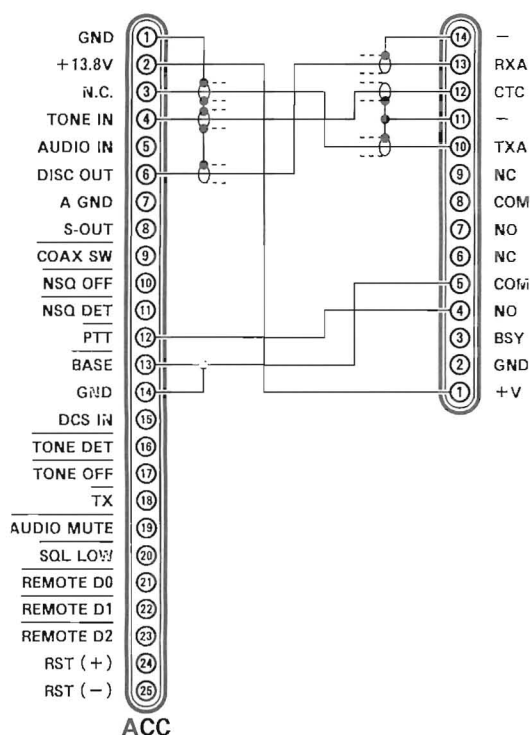
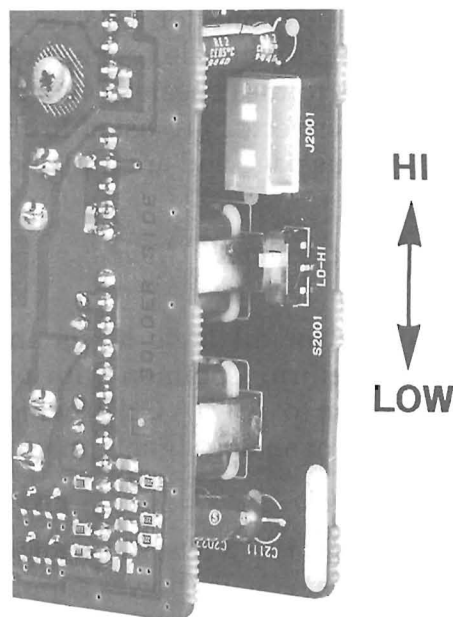

VXR-5000 VTS-100

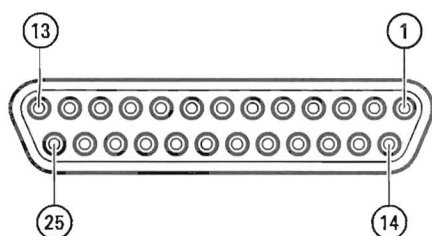

**ACC Jack
DB-25 Pin Numbering**

ACC Connector DB-25 Pin-Out Data

Pin	Signal	Logic I/O	Active State
1	GND	Logic & PS ground	N/A
2	+13.8 V	N/A	N/A
3	TX AUDIO IN	Analog Tx input	N/A
4	TONE IN	Analog TX input	N/A
5	AUDIO IN	Analog Input	N/A
6	DISC OUT	Analog Output	N/A
7	AUDIO GND	Analog Ground	N/A
8	S-METER OUT	Proportional output	N/A
9	COAXIAL SWITCH	Logic Output	Active Low
10	NSQ OFF	Logic Input	Active Low
11	NSQ DET	Logic Output	Active Low
12	PTT	Logic Input	Active Low
13	BASE	Logic Input	Active Low
14	GND	Logic & PS ground	N/A
15	DCS IN	DCS/LTR Data Input	< 2.5V = logic 0 >2.5V = logic 1
16	TONE DET	Logic Output	Active Low
17	TONE OFF	Logic Input	Active Low
18	TX	Logic Output	Active Low
19	AUDIO MUTE	Logic Input	Active Low
20	SQL LOW	Logic Input	Active Low
21	DATA 0	Logic Input	Active Low
22	DATA 1	Logic Input	Active Low
23	DATA 2	Logic Input	Active Low
24	RST (+)	Logic Input	level of 3-5 V DC causes CPU reset
25	RST (-)	Logic Input	

VXR-5000 Accessory Connector

The VXR-5000 repeater is provided with a 25-pin DB-25F female connector for accessories. Use a DB-25M 25-pin male connector to connect accessories to the repeater. The pins on the accessory connector are listed in the table on the previous page and are explained in detail as follows:

1. GND Logic and Power Supply Ground Connection

Chassis ground for all logic levels and power supply return. Common with pin 13. Do not connect to pin 7 (A GND), which is for grounding of analog signals only.

2. +13.8 V Power Supply

This pin provides 13.8 volts, 1.0A, regulated DC from the repeater power supply. Use an 1A fuse to prevent damage to the repeater.

3. TX AUDIO Analog Transmitter Input (Voice Band 300 -3000 Hz)

Approximately 0.245 V_{rms} audio input on this pin will produce full system deviation at 1 kHz (i.e. with 25 kHz channel spacing, \pm 5-kHz deviation). Input impedance is 600 Ω . This audio is injected before transmitter pre-emphasis and limiting stages, so excess signal input levels are clipped.

This pin is intended to be used as a voice-band input to the repeater for telephone patch audio, line control panel audio or community repeater tone panel audio. The repeater must be in BASE mode (pin 13 grounded) for signals on this pin to be fed to the transmitter. The absolute level on this pin can be adjusted by VR2001 (LINE SENSITIVITY control) and also by S2003, which provides 10 dB attenuation, both on the CNTL-2 Unit. Use shielded cable to connect to this pin, connecting the shield to pin 7 (A GND).

4. TONE IN Analog Transmitter Input (Sub-Audible Band 67-250 Hz)

Applying a 0.1 V_{rms} sub-audible tone produces 10% of full system deviation. This input is high impedance (approx. 10 k Ω), and has a flat response characteristic (repeater deviation is constant for a given

signal level over the frequency range of 67-250 Hz). This pin is intended to be used for CTCSS transmission from a community repeater tone panel. This input is applied after limiting and pre-emphasis, and therefore exhibits flat direct FM input characteristics.

Injecting too high a voltage here causes over-deviation of CTCSS, degrading performance. Signals with DC content (DCS or LTR data) *should not* be connected here, but to pin 15. If the repeater is fitted with internal CTCSS, then its output will be present on this pin. Use shielded cable to connect to this pin, connecting the shield to pin 7 (A GND).

5. AUDIO IN Analog Input

Set S2005 on the CNTL-2 Unit to **EXT** to enable audio input to the LINE OUT using this pin. This allows Rx audio to be intercepted (at the DISC OUT pin, see below), and externally processed for special applications, such as descrambling. The normal position of S2005 is **INT**, and in this case, AUDIO IN signals come from Rx audio.

6. DISC OUT Analog Output (Wide-Band 0-3000 Hz)

Received signals with full system deviation produce 1 V_{p-p} audio at this pin. The output is low impedance, and is extracted before de-emphasis and squelch circuitry. This pin should be used as the Discriminator Audio Signal required by most community repeater tone panels and telephone patch units. Use shielded cable to connect to this pin, and connect the shield to pin 7 (A GND).

7. A GND Analog Ground

Connect the shields of any accessory analog signal lines to this pin. Do not connect this pin to pin 1 or pin 13, as an audio hum loop may result.

8. S-OUT S-Meter Output

A DC voltage proportional to the strength of the signal currently being received (Receiver Signal Strength) is output on this pin. This low impedance output is generated by the receiver IF sub-system and

buffered by an internal op-amp. Typical voltages are graphed as follows:

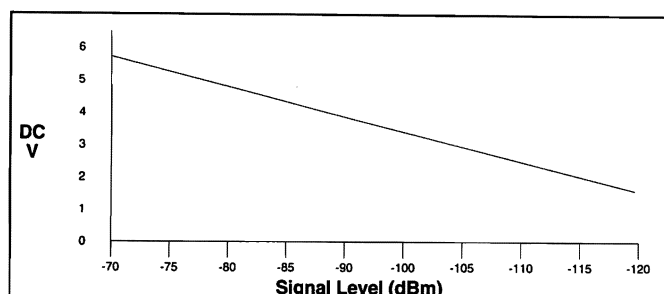

S-Meter Output Proportional Voltage Graph

9. COAX SW Logic Output (Active Low)

This output is intended for controlling an external coaxial switching relay. It is an open collector output which can sink approx. 100 mA when active. This signal only switches if the repeater has been programmed for simplex mode. If programmed for duplex, the signal remains open (at high impedance) at all times.

10. NSQ OFF Logic Input (Active Low)

This input is internally pulled up to 5-V DC. When pulled low by an external device, receiver squelch is canceled. If the internal CTCSS decoder is programmed, pin 17 (TONE OFF) should also be pulled low during monitoring. If the repeater is in the REPEATER mode, the transmitter is *not* keyed when this pin is activated, but an incoming signal on the receiver channel *does* cause the transmitter to be keyed and the signal repeated as normal. Do not apply more than 5 V to this pin, as this can damage the CNTL-1 Unit CPU.

11. NSQ DET Logic Output (Active Low)

This is an open-collector, active-low output capable of sinking about 100 mA. It indicates that the receiver squelch is open. If the squelch control is properly set, this indicates a carrier on the receiver channel, and is sometimes referred to as a COR (Carrier Operated Relay) signal. Some telephone interconnect panels and community repeater tone panels require this signal.

12. PTT Logic Input (Active Low)

This input is internally pulled up to 5-V DC. When pulled low by an external device, it keys the repeater transmitter, provided that the BASE signal is present on pin 13 (indicating the repeater is in the base mode of operation). The pin has no effect if the BASE signal on pin 13 is not present (i.e. the REPEATER mode is selected). Avoid voltage in excess of 5 V on this pin, or internal damage to the CPU on the repeater CNTL-1 unit may result.

13. BASE Logic Input (Active Low)

This input is internally pulled up to 5-V DC. In simplex mode, this pin is not normally used. However, after programming via CE-8 Software and pulled low by an external device, BASE or REPEATER modes of operation can be selected. In BASE mode, the receiver and transmitter operate independently: receiver signals do not key the transmitter. In the alternate (REPEATER) mode, a proper signal on the receive channel causes the transmitter to be keyed and modulated by receiver audio. Avoid voltage in excess of 5 V on this pin or internal damage to the CPU on the repeater CNTL-1 unit may result.

14. GND

This is the chassis ground for all logic levels and power supply return, and is also common with pin 1. Do not connect to pin 7 (A GND), which should only be used for grounding of analog signals.

15. DCS IN Digital Input for DCS / LTR data

This pin accepts sub-audible tones in the range of 6 - 136 Hz for modulation of the transmitter with DCS or LTR data. Internal buffering allows the data to be DC referenced from 5~9 VDC. Signals below 2.5 V are transmitted as Logic "0" while levels above 2.5 V are Logic "1". Voltage in excess of 9 V may cause internal damage.

16. TONE DET Logic Output (Active Low)

This open-collector output can sink about 100 mA, and is activated when the internal CTCSS detects a valid CTCSS tone at the demodulator.

17. *TONE OFF Logic Input (Active Low)*

This input is internally pulled up to 5-V DC. When pulled low by an external device, it disables the internal CTCSS decoder (if enabled). The internal CTCSS encoder section is not affected by this input. Use this input when channel monitoring with squelch action is required (e.g. tone monitor function). Voltage in excess of 5 V on this pin may damage the CPU on the repeater CNTL-1 Unit.

18. *TX Logic Output (Active Low)*

This open-collector logic output is pulled low when the transmitter is activated. It can sink approx. 100 mA. The signal on this pin is always true when the transmitter is on. It is intended to be used where an "ON-AIR" indication is required.

19. *AUDIO MUTE Logic Input (Active Low)*

This input is internally pulled up to 5-V DC. When pulled low by an external device, it disables receiver output to pins 5 & 6 of the modular LINE jack. In the REPEATER mode, the repeat audio is not affected by signals on this pin. Avoid voltage in excess of 5 V on this pin or internal damage to the CPU on the repeater CNTL-1 Unit may result.

20. *SQ LOW Logic Input (Active Low)*

This input is internally pulled up to 5-V DC. When pulled low by an external device it selects the low squelch mode. In low squelch mode, the hysteresis between squelch open and closed is only 3 dB (instead of the normal 6 dB). The squelch closing level is unchanged.

The absolute squelch closing level is set by VR4001 on the RX Unit. For example, if the squelch on the RX Unit has been set to open at -110 dBm in normal mode, then

with the SQ LOW pin grounded, the squelch will now open at about -113 dBm. In either case, the squelch will close at -116 dBm. Avoid voltage in excess of 5 V on this pin, which could damage the CPU on the repeater CNTL-1 Unit.

21, 22 & 23. *REMOTE D0, D1 & D2 Logic Inputs (Active Low)*

These inputs are internally pulled up to 5-V DC. When pulled low by an external device, they select one of the eight pre-programmed repeater operating channels. The logic truth table below shows the combinations for selecting all 8 channels.

In the truth table, "1" represents no connection, and "0" represents a ground connection on the pin.

The channel selection logic is not inhibited while the transmitter is keyed: the repeater will change frequency when instructed, even while transmitting.

Avoid voltage in excess of 5 V on these pins or internal damage to the CPU on the repeater CNTL-1 Unit may result.

VXR-5000 Channel Access (D0-D2, pins 21, 22 & 23)			
CH	D2	D1	D0
1	1	1	1
2	1	1	0
3	1	0	1
4	1	0	0
5	0	1	1
6	0	1	0
7	0	0	1
8	0	0	0

24 & 25. *RST+ & RST- Logic Inputs*

An opto-isolated RESET input is provided between pins 24 and 25. A voltage of between 3 and 15 V resets the repeater microprocessor.

VXR-5000 Line Interface Port

The VXR-5000 is provided with an 8-pin modular jack for line interfacing applications. A Western Electric modular-type RJ45 plug should be used to connect to the jack. The **LINE** jack provides -10 dBm line-level audio for two uses:

- Provides an impedance-balanced, 4-wire audio port with E+M auxilliary signalling.
- Provides audio for SINAD meter connection during alignment procedures (see diagram on page 4-1).

LINE jack pin-out is shown below.

Note that there are both 4-line and 8-line types of modular plugs. If a 4-pin modular plug is used, only the **LINE OUT** and **LINE IN** connections will be made. An 8-pin plug is required to access all lines. In accordance with standard telecommunications interfacing, the line connections on the **LINE** interface jack are impedance balanced, and are described as follows:

Pins 1 & 2. RX SQ+, RX SQ-

An opto-isolator is provided to facilitate E signaling (**EAR**). The opto-isolator comes on when a signal exceeding the receiver squelch appears on the receiver channel (with correct CTCSS tone, if enabled). The **RX SQ-** pin is the emitter, and **RX SQ+** is the collector.

Pins 3 & 4. LINE IN Tx Line Audio

Analog signals between 300 and 3000 Hz supplied to this pair are fed to the transmitter when the repeater is set to the **BASE** mode (**ACC** connector, pin 13 grounded) and keyed either by the **TX KEY** input signal (see below), or by the **PTT** signal on pin 12 of the **ACC** jack. Full system deviation is obtained with a line level of -10 dBm.

Pins 5 & 6. LINE OUT Rx Line Audio

Receiver audio is available from this pair, subject to internal CTCSS decode if the received signal strength is above the squelch threshold. Receiver audio can be monitored by activating the **NSQ OFF** signal on pin 10 of the **ACC** jack.

As shipped from the factory, a 1-kHz receiver signal with full system deviation gives -10 dBm on the line, but this can be varied over the range -55 dBm to +10 dBm by VR2006 and S2004 on the repeater **CNTL-2** Unit.

Pins 7 & 8. TX KEY+, TX KEY-

An opto-isolator is provided to facilitate M signalling (**MIC**). That is, a voltage presented to these pins turns on the opto-isolator and keys the transmitter. The **TX KEY+** pin is the anode of the opto-isolator and **TX KEY-** is the cathode.

Socket J8201

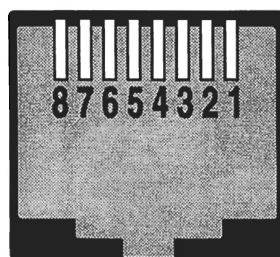

- 1 Rx SQL +
- 2 Rx SQL -
- 3 Line IN
- 4 " "
- 5 Line OUT
- 6 " "
- 7 Tx Key +
- 8 Tx Key -

LINE jack pin-out

Cover Removal and Unit Access

The VXR-5000 repeater uses professional modular card-style unit construction and mounting. Major units are secured in a miniature rack-mount cage for easy access and servicing. Each unit can be removed by unscrewing the mounting-tab screws, unplugging the cables to the unit, then sliding the unit out from the chassis. Plastic guide rails on the chassis body ensure positive insertion and support the units firmly in place.

Opening the Repeater Cabinet

- To remove the cover, remove the 4 screws as shown below and lift the cover off. Unit identification and locations are shown below.

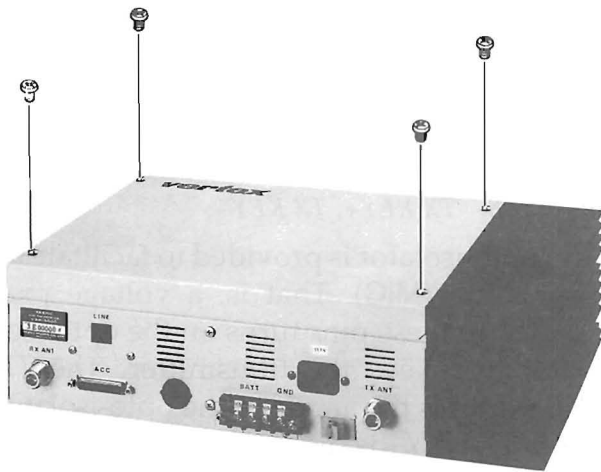

Control Unit Access

- Remove the two screws from the Control Unit mounting tabs to loosen it from the chassis.

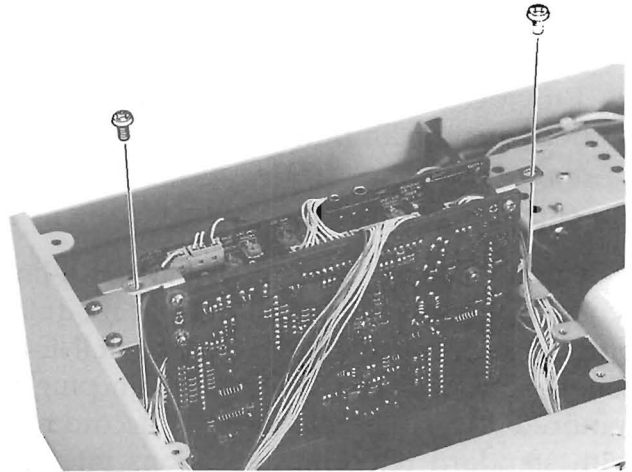

CNTL Units 1 & 2

TX Unit Access

- Remove 4 screws from the TX unit mounting tabs to loosen it from the chassis.
- Remove the 10 screws affixing the top cover, and lift it off (note the type of screws used) to expose the VCO Unit.

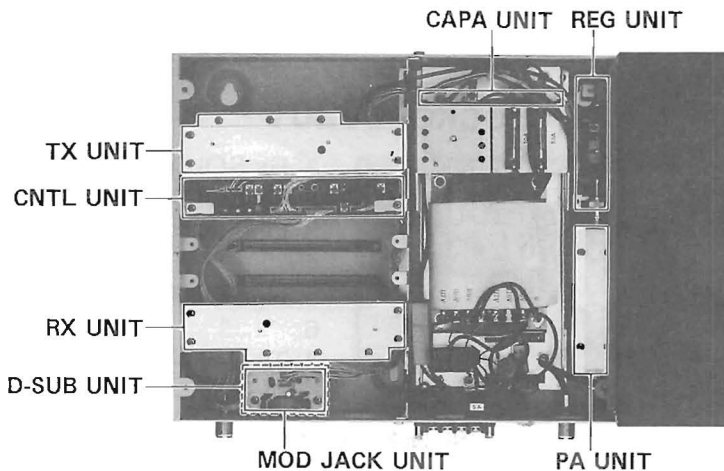

Unit Location & Identification

- This completes normal disassembly for servicing, to completely remove the unit, disconnect the TX coaxial cable from the BNC jack, and unplug the two cables leading to the CNTL Unit from J3001 & J3002.

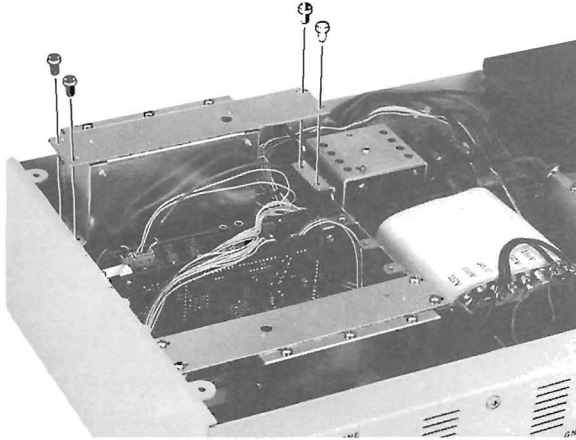

TX Unit

PA Unit Access

- First remove the 6 large screws affixing the heat sink/PA Unit to the chassis. Loosen the heat sink unit from the chassis.

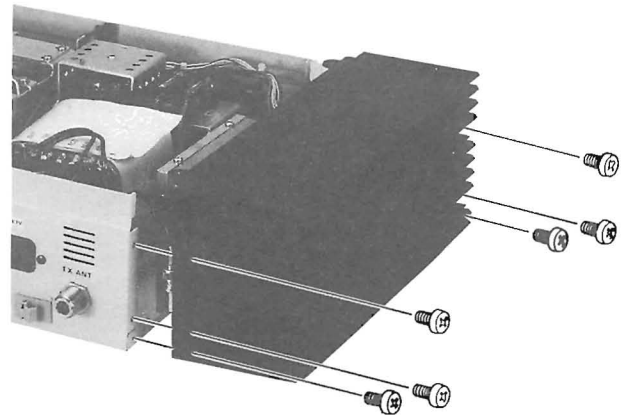

RX Unit Access

- This unit is removed in the same manner as described for the TX Unit. Control Unit cables connect to J4001 & J4002. To completely remove the unit, disconnect the coaxial cable leading to the RX ANT jack from the BNC jack.

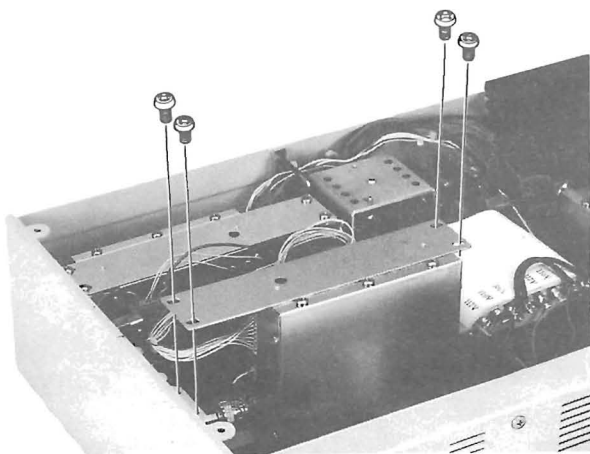

RX Unit

- Next remove the TX ANT cable from the BNC connector on the TX Unit, and remove the 8 screws affixing the top cover to expose the PA Unit (see below).

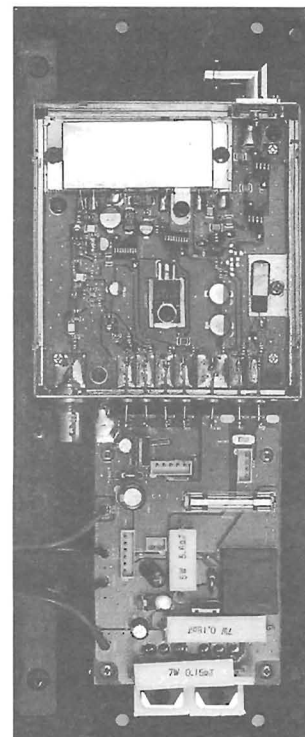

TX PA Unit

Notes: