

VHF FM Transceiver

VX-4000V

Service Manual

©2002 VERTEX STANDARD CO., LTD. Printed in Japan.

VERTEX STANDARD CO., LTD.
4-8-8 Nakameguro, Meguro-Ku, Tokyo 153-8644, Japan

VERTEX STANDARD

US Headquarters

10900 Walker Street, Cypress, CA 90630, U.S.A.

International Division

8350 N.W. 52nd Terrace, Suite 201, Miami, FL 33166, U.S.A.

YAESU EUROPE B.V.

P.O. Box 75525, 1118 ZN Schiphol, The Netherlands

YAESU UK LTD.

Unit 12, Sun Valley Business Park, Winnall Close
Winchester, Hampshire, SO23 0LB, U.K.

VERTEX STANDARD HK LTD.

Unit 5, 20/F., Seaview Centre, 139-141 Hoi Bun Road,
Kwun Tong, Kowloon, Hong Kong

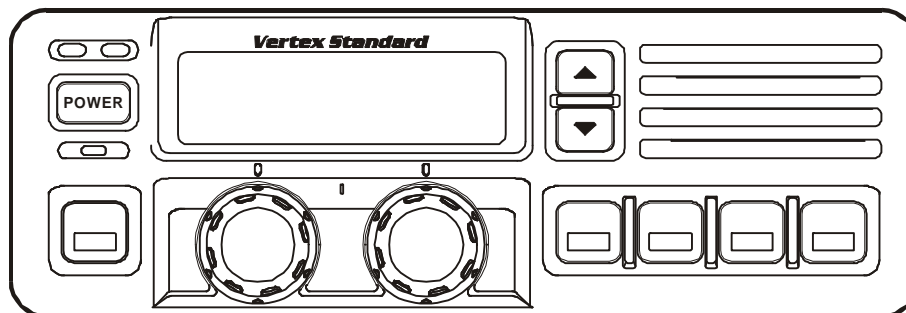

Introduction

This manual provides technical information necessary for servicing the VX-4000V FM Transceiver.

Servicing this equipment requires expertise in handling surface-mount chip components. Attempts by non-qualified persons to service this equipment may result in permanent damage not covered by the warranty, and may be illegal in some countries.

Two PCB layout diagrams are provided for each double-sided circuit board in the Transceiver. Each side of is referred to by the type of the majority of components installed on that side (“leaded” or “chip-only”). In most cases one side has only chip components, and the other has either a mixture of both chip and leaded components (trimmers, coils, electrolytic capacitors, ICs, etc.), or leaded components only.

While we believe the technical information in this manual to be correct, VERTEX STANDARD assumes no liability for damage that may occur as a result of typographical or other errors that may be present. Your cooperation in pointing out any inconsistencies in the technical information would be appreciated.

Contents

Operating Manual Reprint	1-1
Cloning	2-1
Specifications	2-2
Exploded View & Miscellaneous Parts ...	3-1
Block Diagram	3-2
Interconnection Diagram	3-4
Circuit Description	4-1
Alignment	5-1

Board Unit (Schematics, Layouts & Parts)

MAIN Unit	6A-1
DISPLAY Unit	6B-1
KEY Unit	6C-1
VR Unit	6D-1
MIC CONN Unit	6D-2

Optional Board Unit (Schematics, Layouts & Parts)

F2D-8 2-Tone Decode Unit	7A-1
F5D-14 5-Tone Unit	7B-1
FVP-25 Encryption / DTMF Pager Unit	7C-1
VTP-50 VX-Trunk Unit	7D-1

CONTROLS & CONNECTORS

Front Panel

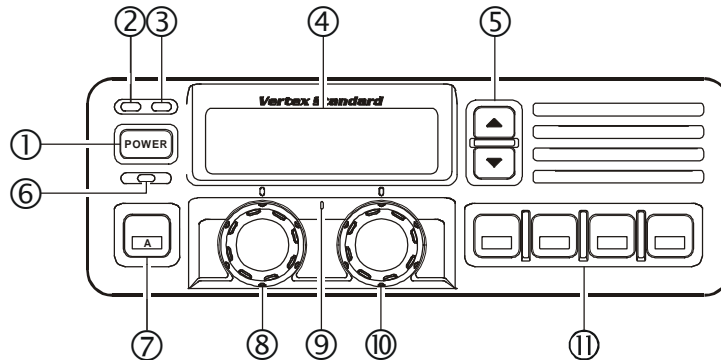

① **POWER Button**

Press the button to turn the transceiver ON and OFF.

② **TX Indicator**

This lamp glows red when the radio is transmitting.

③ **BUSY Indicator**

This lamp glows green when the channel is busy.

④ **Liquid Crystal Display**

The display include an 8-character alpha-numeric section showing channel and group names, status and identity information, and error messages. Additional indicators on the display show priority channel assignments and scan include / exclude selection.

⑤ **▲/▼ Button**

Pressing these buttons changes the current group (and displayed group number or name). Holding this button for more than 1/2 second causes the function to repeat.

⑥ **SQC Indicator**

This lamp glows orange when incorrect position at the setting of CE35.

⑦ **Programmable Function Button (PF button)**

This button can be set up for special applications, such as high/low power selection, monitor, dimmer, talk-around, and call alert function, as determined by your network requirements and programmed by your VERTEX STANDARD dealer.

⑧ **VOLUME Knob**

This knob sets the volume of the receiver.

⑨ **EMERGENCY Microphone**

The emergency microphone is located behind this small slit. When the emergency feature is activated, this Microphone is enabled.

⑩ **CHANNEL Selector Knob**

This knob select the operating channel.

⑪ **Programmable Function Button (PF button)**

This button can be set up for special applications, such as high/low power selection, monitor, dimmer, talk-around, and call alert function, as determined by your network requirements and programmed by your VERTEX STANDARD dealer.

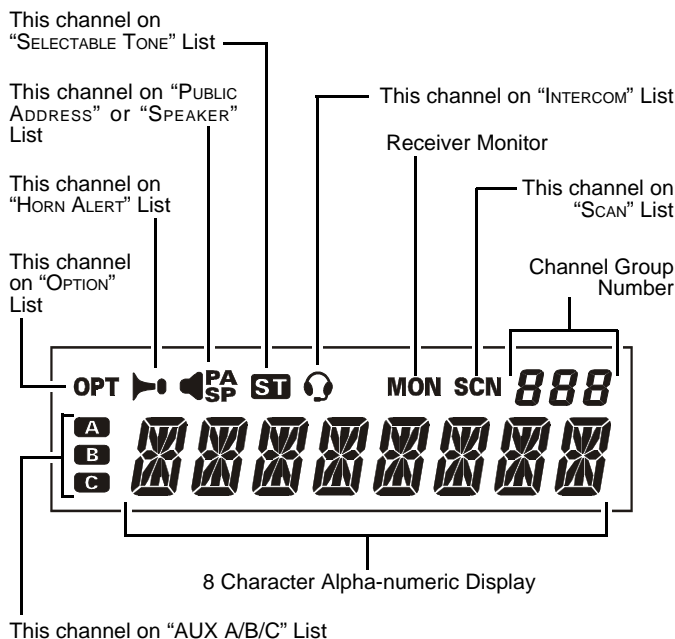

CONTROLS & CONNECTORS

Side Panel

Microphone Jack (It is on both sides.)
Connect the microphone plug to this jack.

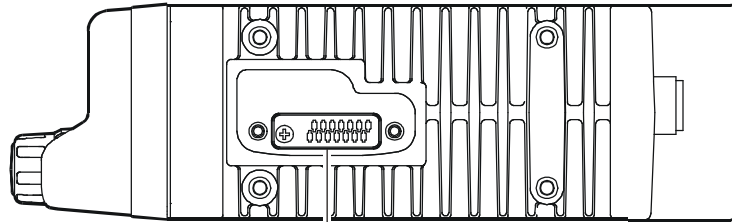

Microphone Jack

REAR (Heatsink)

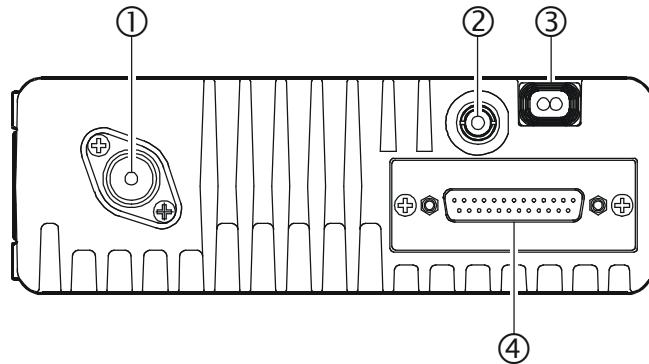

① **Antenna Socket**

The 50-ohm coaxial feedline to the antenna must be connected here, using a type-M (PL-259) plug.

② **External Speaker Jack**

An external loudspeaker may be connected to this 2-contact, 3.5-mm mini-phone jack.

Caution: Do not connect this line to ground, and be certain that the speaker has adequate capability to handle the audio output from the VX-4000.

③ **13.8-V DC Cable Pigtail w/Connector**

The supplied DC power cable must be connected to this 2-pin connector. Use only the supplied fused cable, extended if necessary, for power connection.

④ **DSUB 25-Pin Accessory Connector**

External TX audio line input, PTT (Push To Talk), Squelch, and external RX audio line output signal may be obtained from this connector for use with accessories such as data transmission/reception modems, etc.

BASIC OPERATION OF THE TRANSCEIVER

Important! - Before turning on the radio the first time, confirm that the power connections have been made correctly and that a proper antenna is connected to the antenna jack.

Switching Power ON/OFF

Push the **POWER** switch turn on the radio. The display will become illuminated. The radio will start up on the last channel used prior to shut-down during the previous operating session.

Turn the **CHANNEL** selector knob to choose the desired operating channel. A channel name will appear on the display. If you want to select the operating channel from a different Memory Channel Group, press the **UP** (▲) or **DOWN** (▼) button to select the Memory Channel Group you want before selecting the operating channel.

Setting the Volume

Turn the **VOLUME** knob clockwise to increase the volume, and counterclockwise to decrease it. If no signal is present, press and hold in the **MON** button more than 1/2 seconds; background noise will now be heard, and you may use this to set the **VOLUME** knob for the desired audio level. Press and hold the **MON** button more than 1/2 seconds to quiet the noise and resume normal (quiet) monitoring.

Transmitting

To transmit, wait until the “**BUSY**” indicator is off (the channel is not in use), and press the **PTT** (Push-To-Talk) switch on the side of the microphone (the “**TX**” indicator will appear or the “**TX**” indicator will glow red). While holding in the **PTT** switch, speak across the face of the microphone in a clear, normal voice level, and then release the **PTT** switch to receive.

Selecting Groups and Channels

- Press the **UP** (▲) or **DOWN** (▼) button (repeatedly, if necessary) to select a different group of channels.
- Turn the **CHANNEL** selector knob to select a different channel *within the current group*.

Automatic Time-Out Timer

If the selected channel has been programmed for automatic time-out, you must limit the length of each transmission. While transmitting, a beep will sound five seconds before time-out. Another beep will sound just before the deadline; the “**TX**” indicator will disappear and transmission will cease soon thereafter. To resume transmitting, you must release the **PTT** and wait for the “penalty timer” to expire (if you press the **PTT** before this timer expires, the timer restarts, and you will have to wait another “penalty” period.)

ADVANCED OPERATION

Programmable Function Button (PF button)

The VX-4000 includes the seven **Programmable Function Buttons (PF button)**. The **PF** button functions can be customized, via programming by your VERTEX STANDARD dealer, to meet your communications/network requirements. Some features may require the purchase and installation of optional internal accessories. The possible **PF** button programming features are il-

lustrated at the below, and their functions are explained on next page. For further details, contact your VERTEX STANDARD dealer. For future reference, check the box next to each function that has been assigned to the **PF** button on your particular radio, and keep it handy.

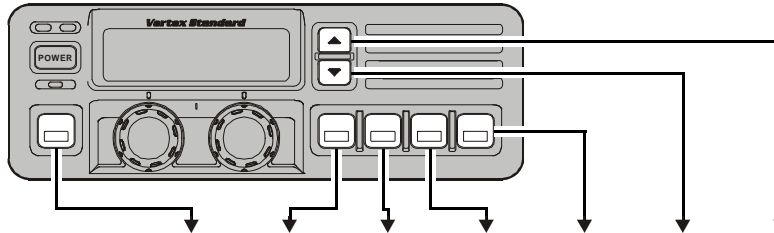

Functions	Programmable Function Button (PF button)													
	<1.5 sec	>1.5 sec	<1.5 sec	>1.5 sec	<1.5 sec	>1.5 sec	<1.5 sec	>1.5 sec	<1.5 sec	>1.5 sec	<1.5 sec	>1.5 sec	<1.5 sec	>1.5 sec
None														
SCAN (SCN)														
Dual Watch														
Call/Reset														
Talk-Around (TA)														
Noise Blanker* (NB)														
Alpha Numeric (A/N)														
DIMMER (DIM)														
Emergency (EMG)														
Horn Alert (HA)														
Home Channel (HOM)														
Intercom (IC)														
Low Power (LOW)														
GRP UP														
GRP DWN														
CH UP														
CH DWN														
AUX A														
AUX B														
AUX C														
Public Address (PA)														
Monitor (MON)														
RCL														
Selectable Tone (ST)														
SP**														
Squish Level (SQL)														
Encryption*** (OPT)														

* for VX-4000L ** requires RMK-4000 *** requires Encryption Unit

ADVANCED OPERATION

Channel Scan

The Scanning feature is used to monitor multiple signals programmed into the transceiver. While scanning, the transceiver will check each channel for the presence of a signal, and will stop on a channel if a signal is present.

To activate scanning:

- Press the assigned **PF** button of the “**Scan**” momentarily to activate scanning.
- The scanner will search the channels, looking for active ones; it will pause each time it finds a channel on which someone is speaking.

To stop scanning

- Press the assigned **PF** button of the “**Scan**”.
- Operation will revert to the channel to which the **CHANNEL** selector knob is set.

Note:Your dealer may have programmed your radio to stay on one of the following channels if you press the **PTT** switch during scanning pause:

- Current channel (“Talk Back”)
- “Last Busy” channel
- “Priority” channel
- “Home” channel
- Scan Start” channel

Dual Watch

The Dual Watch feature is similar to the Scan feature, except that only two channels are monitored:

- The current operating channel; and
- The “Priority” channel.

To activate Dual Watch:

- Press the assigned **PF** button of the “**Dual Watch**”.
- The scanner will search the two channels; it will pause each time it finds a channel on which someone is speaking.

To stop Dual Watch:

- Press the assigned **PF** button of the “**Dual Watch**”.
- Operation will revert to the channel to which the **CHANNEL** selector knob is set.

ARTS (Auto Range Transpond System)

This system is designed to inform you when you and another ARTS-equipped station are within communication range.

During ARTS operation, your radio automatically transmits for about 1 second every 25 (or 55) seconds (the interval is programmed by Dealer) in an attempt to Shake hands with the other station. If you move out of range for more than one minute, your radio senses that no signal has been received, a ringing beeper will sound. If you subsequently move back into range, as soon as the other station transmits, your beeper will sound.

The PF Button Function

The **PF** (Programmable Function) button can be programmed by the dealer to provide two of the other functions described below.

To activate the primary Accessory function, press the **PF** button momentarily. To access the secondary Accessory function (which may include the Alarm), press and hold the **PF** button for 1.5 seconds or longer.

Call/Reset

When this feature is programmed and a selective call has been received, momentarily press the assigned **PF** button of the “**Call/Reset**” to reset the flashing indicator and mute the receiver, otherwise press the assigned **PF** button of the “**Call/Reset**” to sent your radio’s identification code (ANI) to the dispatcher.

Talk-Around

The feature causes the assigned **PF** button of the “**Talk-Around**” to select simplex operation on semi-duplex channels: the transmit frequency becomes the same as the receive frequency (regardless of any programmed offset for the channel).

Note:*This feature has no effect on simplex channels. After pressing the button, “TA” is displayed on the LCD.*

Noise Blanker (for VX-4000L)

Because local noise can be particularly troublesome in the VHF Low-Band frequency spectrum, the Low-Band version of the VX-4000 includes a Noise Blanker feature, which may be toggled on and off by pressing the assigned **PF** button of the “**Noise Blanker**” for the appropriate length of time.

ADVANCED OPERATION

Alpha Numeric

Press the assigned **PF** button of the “**Alpha Numeric**” to switch the display between the Group/Channel number, and the Group/Channel name (alphanumeric). A tone will sound each time you switch between numerical and alphanumeric display.

DIM

Press the assigned **PF** button of the “**DIM**” to adjust the brightness of the display and key backlight.

EMG (Emergency)

Press the assigned **PF** button of the “**EMG**” to initiate an emergency call (requires ANI board). When an emergency call is made, no tone is emitted and the display does not change. To end the emergency call, turn the transceiver power OFF.

HA (Horn Alert)

Press the assigned **PF** button of the “**HA**” to turn the Horn Alert function ON or OFF. If you receive a call from the base station with 2Tone or DTMF signaling, horn alert will activate. When you turn Horn Alert ON, a tone will sound and “” appears on the display.

Home (Home Channel)

Press the assigned **PF** button of the “**Home**” to select the pre-programmed Home Channel. Press it again to return to the previous channel. If used while scanning, pressing this key a second time will change to the revert channel.

IC (Intercom)

This feature requires dual head configuration. Press the assigned **PF** button of the “**IC**” to turn the intercom feature ON or OFF. While ON, you can press the PTT switch to communicate to another control head operator without transmitting over the air. When you press this key, a tone sounds and “” appears on the display. The intercom can be used even while scanning and receiving a call.

Low Power

Press the assigned **PF** button of the “**Low Power**” to set the radio's transmitter to the “Low Power” mode. Press this key again to return to “High Power” operation when in difficult terrain.

GRP UP/DWN

Press the assigned **PF** button of the “**GRP UP**” or “**GRP DWN**” to select a different group of channels.

CH UP/DWN

Press the assigned **PF** button of the “**CH UP**” or “**CH DWN**” to select a different channel within the current group.

AUX A/B/C

Press the assigned **PF** button of the “**AUX A**”, “**AUX B**”, or “**AUX C**” to turn the output port (respectively).

PA (Public Address)

Press the assigned **PF** button of the “**PA**” to use the transceiver as a PA amplifier. When you enable this function, a tone sounds and “PA” appears on the display. The public address can be used even while scanning and receiving a call.

MONI (Monitor)

Press the assigned **PF** button of the “**MONI**” momentarily to cancel CTCSS and DCS signaling squelch; the “**MON**” icon appears on the display. Press and hold this key for 1/2 seconds to hear background noise (unmute the audio); the **MON** icon blinks on the display.

RCL (Channel Recall)

During scan, you can press the assigned **PF** button of the “**RCL**” to select the last called channel.

ST (Selectable Tone)

Press the assigned **PF** button of the “**Selectable Tone**”, then rotate the CHANNEL selector knob to select a 2-Tone.

SP

Press the assigned **PF** button of the “**SP**” to switch “Front panel”, “Front panel & Body” and “Body” speaker. When “Body” is selected, a tone sounds and the “SP” icon appears on the display. You can use this function while scanning and receiving a call. However, all audio will be emitted from the PA speaker.

ADVANCED OPERATION

SQL (Squelch Level)

You can manually adjust the squelch level using this function:

1. Press the assigned **PF** button of the “**SQL**”. A tone sounds and SQL appears on the display with the current squelch level.
2. Rotate the **CHANNEL** selector knob to select the desired level.
3. Press the this key. A tone sounds and the display returns to the normal channel.

Encryption (Option)

When the Voice Scrambler feature is enabled, pressing the assigned **PF** button of the “**Encryption**” toggles the Scrambler on and off.

OPTIONAL ACCESSORIES

MH-25 _{B7A}	Microphone
MH-53 _{C7A}	Heavy Duty Microphone
MH-53 _{A7A}	Heavy Duty Microphone w/Noise Canceler
MH-53 _{B7A}	Heavy Duty DTMF Microphone w/Noise Canceler
CE35	Programming Software
CT-70	Radio Programming Cable (Requires VPL-1)
CT-71	Radio to PC Programming Cable
CT-72	Radio to Radio Programming Cable
CT-81	Cable for RMK-4000 (6 m)
CT-82	Cable for RMK-4000 (2.5 m)
CT-83	Cable for RMK-4000 (0.6 m)
CNT-4000	Control Head
RF DECK	RF Deck w/MMB-75 (for Dual Band Installations)
RMK-4000SH	Remote Kit (for Single Transceiver)
RMK-4000DH	Remote Kit (for Dual-Head Installations)
RMK-4000DB	Remote Kit (for Dual Band Installations)
RMK-4000DBH	Remote Kit (for Dual Band plus Dual Head Installations)
F2D-8	2-Tone Decode Unit (Requires FIF-7)
F5D-14	5-Tone ENC-DEC Unit (Requires FIF-7)
VTP-50	VX-Trunk Unit (Requires FIF-7)
FVP-25	Encryption/DTMF pager Unit (Requires FIF-7)
FP-1023	External 23A Power Supply
MLS-100	Mobile Loud speaker (12 W Peak Power)
MMB-75	Mobile Mounting Bracket
MMB-76	Locking Mobile Mounting Bracket
LF-1	Line Filter
FIF-7	Inter face Board (for F2D-8, F5D-14, VTP-50, FVP-25)
CN-6	Inter face Board (for Accessories)
FIF-8	Flash ROM Adapter

DSUB 25-PIN ACCESSORY CONNECTOR

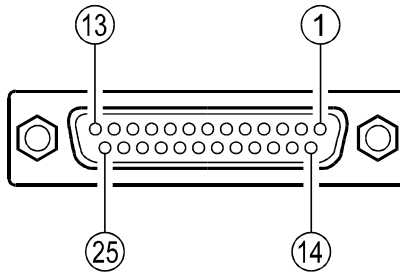

DSUB 25-Pin Numbering

Pin 1: RSSI [Analog Output]

A DC voltage proportional to the strength of the signal currently being received (Receiver Signal Strength Indicator) is provided on this pin. This low impedance output is generated by the receiver IF sub-system and buffered by an internal op-amp. Typical voltages are graphed as follows:

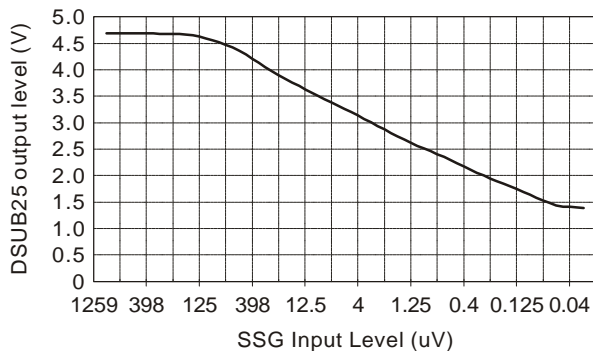

Pin 2, 3, 4, 5 & 6: AI1, AI2, AI3, AI4 & AI5

[Universal Input Port]

These input port features can be programmed via the CE35 programmer. The same item can not be chosen twice.

To select the "Input port" page, (View \Rightarrow Common View \Rightarrow DSUB-25pin connector \Rightarrow Input port).

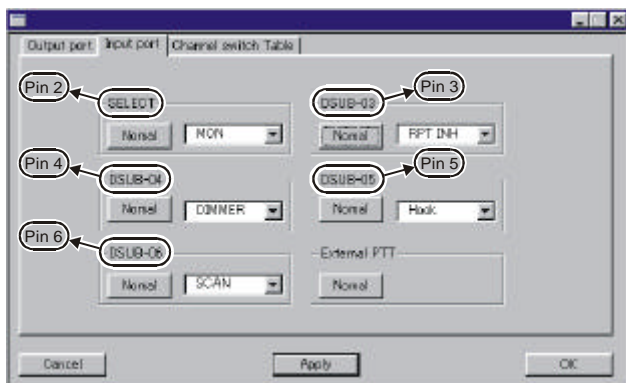

LOGIC level (+5V / 0V) input (Low active).
High Impedance input.

None
MON

This feature is the same as pressing and holding in the Monitor key.

DIM
Hook

LCD illumination dimmer "on."
Activates the Hook1 feature.

SCAN

Activates the scanner.

G-SCAN

Activates the Group scanner.

RPT INH

Disables the repeater feature during Multi Deck operation.

ENG

Activates the Emergency feature.

Home

Switches to the Home Channel.

CH SW0

Memory channel recall
(Channel Switch Table bit 0)

CH SW1

Memory channel recall
(Channel Switch Table bit 1)

CH SW2

Memory channel recall
(Channel Switch Table bit 2)

CH SW3

Memory channel recall
(Channel Switch Table bit 3)

Example

If you assign "CH SW0" and "CH SW1" to the Universal Input Port, you can recall Channels 1-3 as shown below.

Channel	CH SW0	CH SW1
1	1	0
2	0	1
3	1	1

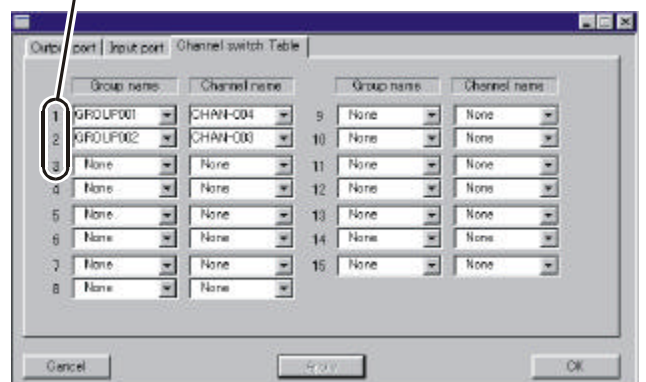

Similarly, if you assign “CH SW0,” “CH SW1,” and “CH SW2” to the Universal Input Port, you can recall Channels 1~7 as shown below:

Channel	CH SW0	CH SW1	CH SW2
1	1	0	0
2	0	1	0
3	1	1	0
4	0	0	1
5	1	0	1
6	0	1	1
7	1	1	1

If you need to recall all memory channels (15 CH) from the External Controller via the Universal Input Port, you should assign the “All Channel Recall” Command (CH SW 0 ~ CH SW 3) to the Universal Input Port.

In this case:

Channel	CH SW0	CH SW1	CH SW2	CH SW3
1	1	0	0	0
2	0	1	0	0
3	1	1	0	0
4	0	0	1	0
5	1	0	1	0
6	0	1	1	0
7	1	1	1	0
8	0	0	0	1
9	1	0	0	1
10	0	1	0	1
11	1	1	0	1
12	0	0	1	1
13	1	0	1	1
14	0	1	1	1
15	1	1	1	1

The Memory Channel is determined via the CE35 Programmer. (View Common View DSUB-25pin connector Channel switch Table).

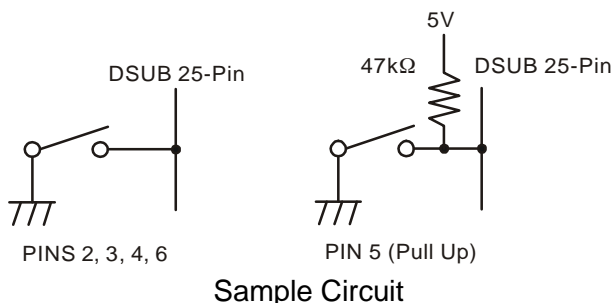
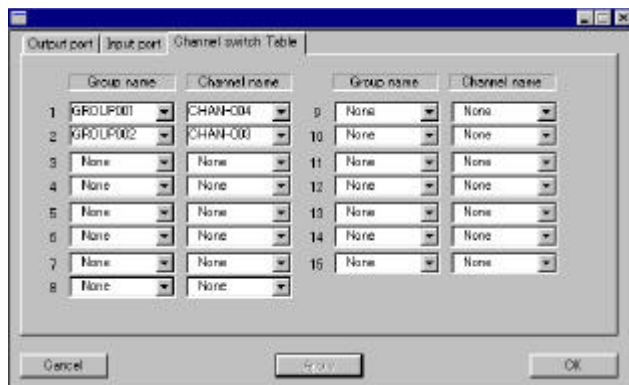

Pin 7: E [GND]

Ground for all logic levels and power supply return.

Pin 8: AO2 [Universal Output Port]

Open collector output. Output voltage 0 ~ 5 V, Max. sink current 30 mA.

The possible programming features (use CE35) are illustrated below.

A KEY/B KEY/C KEY/D KEY/E KEY/HA/Invert

Refer to the “Pins 20, 21, & 22” section for details.

Pin 9: TXD2 [Digital Output for Alignment software]

Connect to the RS232C cable (requires FIF-8 and CT-88)

Pin 10: RXD2 [Digital Input for Alignment software]

Connect to the RS232C cable (requires FIF-8 and CT-88)

Pin 11: TXS [EXT PTT]

Shorting this port to ground causes the transceiver to be placed in the Transmit mode, while opening the connection to this port returns the transceiver to the Receive mode.

Pin 12: MCM [MIC Mute]

MIC mute on: Level High (5V)

MIC mute off: Open

LOGIC level (+5V / 0V) output.

When the PTT/EXT PTT switch is pressed, this pin switches to “open.”

Pin 13: MD/DI [Digital Input for DATA Communications]

○ TX Hi-speed Data Input Type (jumper JP2006).

Input level 800 mV/600 Ohms, Max.input 1.2V

○ Tx Low-speed Data input Type (Jumper JP2007). Input level 40 mV/600-Ohms

If the Jumper setting is “Low-speed Data” (JP2007 jumpered), this port is usable in the AUDIO (300~3000 Hz) range.

If the jumper setting is “HI-speed Data” (JP2006 jumpered), this port is usable for 9600 bps DATA communications, because the filter and limiter are not engaged in the Audio line.

Pin 14: SB [13.8 V/5 V DC Output]

○ Switched 13.8V output for supplying power to an accessory (jumper JP2009).

○ Switched and regulated DC 5.0V output for supplying power to an accessory (jumper JP2008).

Maximum output current is 200 mA

Pin 15: IGN [Ignition Sense feature]

The VX-4000 may automatically be switched to the STAND-BY mode when the vehicle's ignition key is turned on.

Maximum current is 20 mA.

This feature is only enabled on transceivers configured for Dual Deck operation.

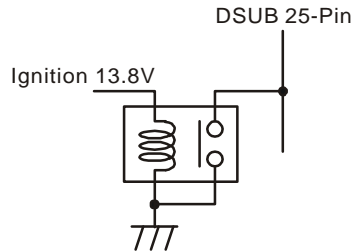

Pin 16: NC [NO connection]

Pin 17: AFO [Digital Output for DATA Communications]

- RX Hi-speed Data Output Type (jumper JP2004). output level 600 mV/10k Ohms
- RX Low-speed Data Output Type (jumper JP2005). output level 200 mV/600 Ohms

If the Jumper setting is "Low-speed Data" (JP2007 jumpered), this port is usable in the AUDIO (300~3000 Hz) range.

If the jumper setting is "HI-speed Data" (JP2006 jumpered), this port is usable for 9600 bps DATA communications, because the filter and limiter are not engaged in the Audio line.

Pin 18: E [GND]

Ground for all logic levels and power supply return.

Pin 19: NC [No Connection]

Pins 20, 21, & 22: AO1, AO3 & AO4

[Universal Output Port]

LOGIC level (+5V / 0V) output.

The logic output appears at these pins when the front panel's PF key is turned on.

The possible programming features (use CE35) are illustrated below.

If the HA feature is assigned to these ports, a current amplifier must be connected between the Horn circuit and the port.

A KEY/B KEY/C KEY/D KEY/E KEY/HA/Invert

Pin 23: SQ [Squelch Signal Output]

Open collector output. Max. sink current 10 mA.

A Signal is present (Squelch is open): Level High
No Signal is present (Squelch is closed): Open

When you connect the solder jumper on J2002, this port changes to PULL UP (5 V) output.

This status can be changed by CE35 programmer.

Pin 24: SPM [Speaker Mute Output]

Open collector output.

External Speaker mute on: Level High

External Speaker mute off: Open

Pin 25: ME [GND]

Chassis ground.

Note:

Cloning

The **VX-4000** includes a convenient "Clone" feature, which allows the programming data from one transceiver to be transferred to another **VX-4000**. Here is the procedure for Cloning one radio's data to another.

Note: When a cloning isn't made, you correct the following part using "CE35."

When a "Radio to Radio Clone" which is in the "Miscellaneous" menu is "Disabled," change this menu to "Enabled."

1. Turn both transceivers off.
2. Remove the plastic cap and its two mounting screws from the **Microphone** jack on the transceiver. Do this for both transceivers.
3. Connect the optional **CT-72** cloning cable between the **Microphone** jacks of the two transceivers.
4. On the **Destination** transceiver, press and hold the **PF Button** (just below the **POWER Button**) while turning the transceiver on.
5. Now, on the **source** transceiver, press and hold the **▼ Button** while turning the transceiver on. Data will now be transferred to the **Destination** transceiver from the **source** transceiver.
6. If there is a problem during the cloning process, sound an error beep from source the transceiver. Check your cable connections and battery voltage, and try again.
7. If cloning is a successful, turn the **Destination** transceiver off. Now turn the **source** transceiver off.
8. Disconnect the **CT-72**. Replace the plastic cap and its two mounting screws.
9. You can then turn the transceivers back on, and begin normal operation.

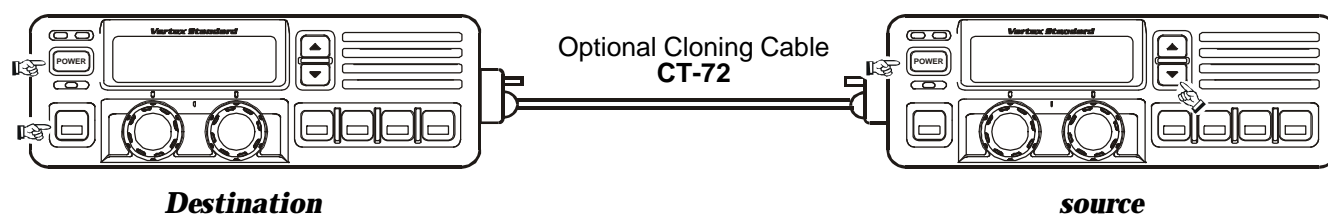

Dealer Programming of VTP-50 and F5D-14

These procedures are designed to be used by the installing technician after the **VTP-50** and **F5D-14** has been installed in the transceiver. To program a **VX-4000**'s **VTP-50** and **F5D-14** board, you will need the **CT-71** programming interface cable, the **CE-26** Programming diskette, and an IBM PC/AT or PS/2-compatible type computer.

To enter the Programming mode, use the following procedure:

1. Turn the transceiver off.
2. Turn on the transceiver while holding in the **PF Button** (just below the **▼ Button**).

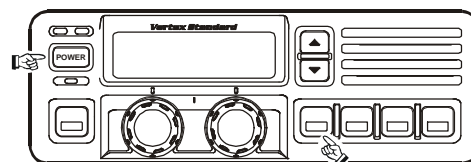

Specifications

GENERAL

Number of Channels:	250 channels
Frequency Range:	134 - 160 MHz (A), 148 - 174 MHz (C)
Channel Spacing:	12.5 / 25 / 30 kHz
Power Supply Voltage:	13.8 VDC
Current Consumption:	Standby: 400 mA Receive: 2.1 A Transmit: 12 A
Ambient Temperature Range:	-30°C to +60°C (-22°F to +140°F)
Frequency Stability:	±2.5 ppm
RF Input-Output Impedance:	50 Ohms
Audio Output Impedance:	4 Ohms
Dimensions:	7" (w) x 2.4" (H) x 7.7" (D) (178 x 60 x 195 mm)
Weight:	4.9 lbs. (2.2 kg)

RECEIVER (Measurements made per EIA standard TIA/EIA-603)

Circuit Type:	Double-conversion Super-heterodyne
Sensitivity(EIA 12 dB SINAD):	0.25 μ V
Adjacent Channel Selectivity:	85 dB / 75 dB
Intermodulation:	76 dB
Spurious and Image Rejection:	90 dB
Audio Response:	+3 / -8 dB from the 6 dB / oct. re-emphasis curve
Audio Output:	5 W @ 4 Ohms, 10 % THD 10 W @ 4 Ohms w/<10 % THD (Option)

TRANSMITTER (Measurements made per EIA standard TIA/EIA-603)

Power Output:	50 / 25 W
Modulation:	16K0F3E, 11K0F3E
Max Deviation:	5.0 / 2.5 kHz
Conducted Spurious Emissions:	70 dB Below Carrier
FM Hum & Noise:	45 dB (25 kHz) / 40 dB (12.5 kHz)
Audio Response:	+1 / -3 dB from the 6 dB / oct-8
Audio Distortion (@ 1 kHz):	< 3 %

*Measurements per EIA standards unless noted above.
Specifications subject to change without notice or obligation.*

Exploded View & Miscellaneous Parts

Screw List			
REF.	VXSTD P/N	Description	Qty.
1	U20306007	BINDING HEAD SCREW M3x6B	4
2	U20306002	BINDING HEAD SCREW M3x6NI	6
3	U24308002	TAPTITE SCREW M3x8NI	9
4	U23206001	TAPTITE SCREW M2.6x6	14
5	U20308002	BINDING HEAD SCREW M3x8NI	2
6	U24208001	TAPTITE SCREW M2.6x8	1
7	U20305007	BINDING HEAD SCREW M3x5B	2
8	U32450007	FLAT HEAD SCREW M2.6x5B	2
9	U31306007	OVAL HEAD SCREW M3x6B	2
10	S5000182	SCREW JFS-4S-B1MW	2

Accessories		
Description	VXSTD P/N	Qty.
BLADE FUSE ATC 15A	Q0000075	2
DC CABLE 02P 15AX2	T9021015	1
KNOB CAP	RA0254100	5
NAME PLATE	RA0254700	1

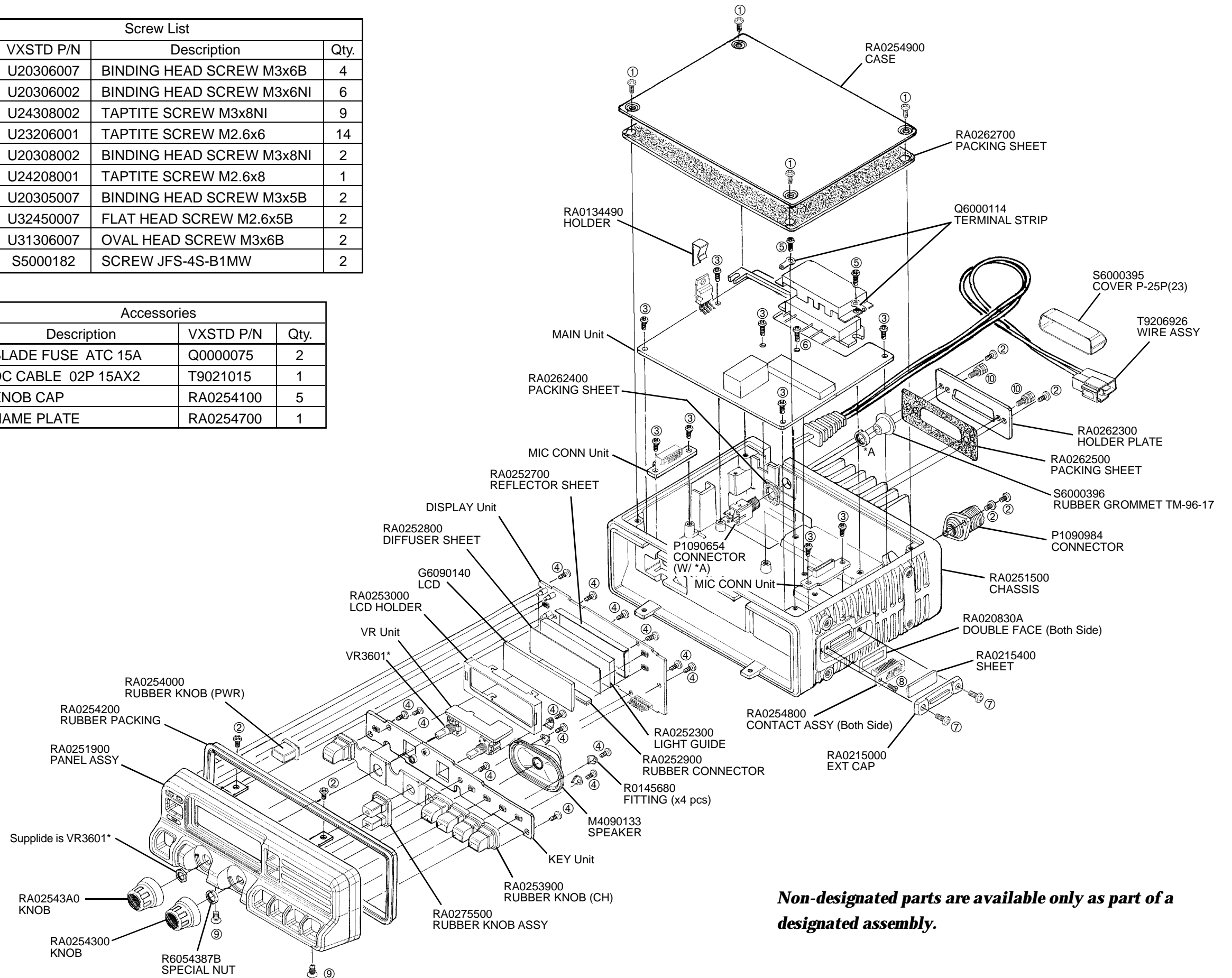

Non-designated parts are available only as part of a designated assembly.

Block Diagram

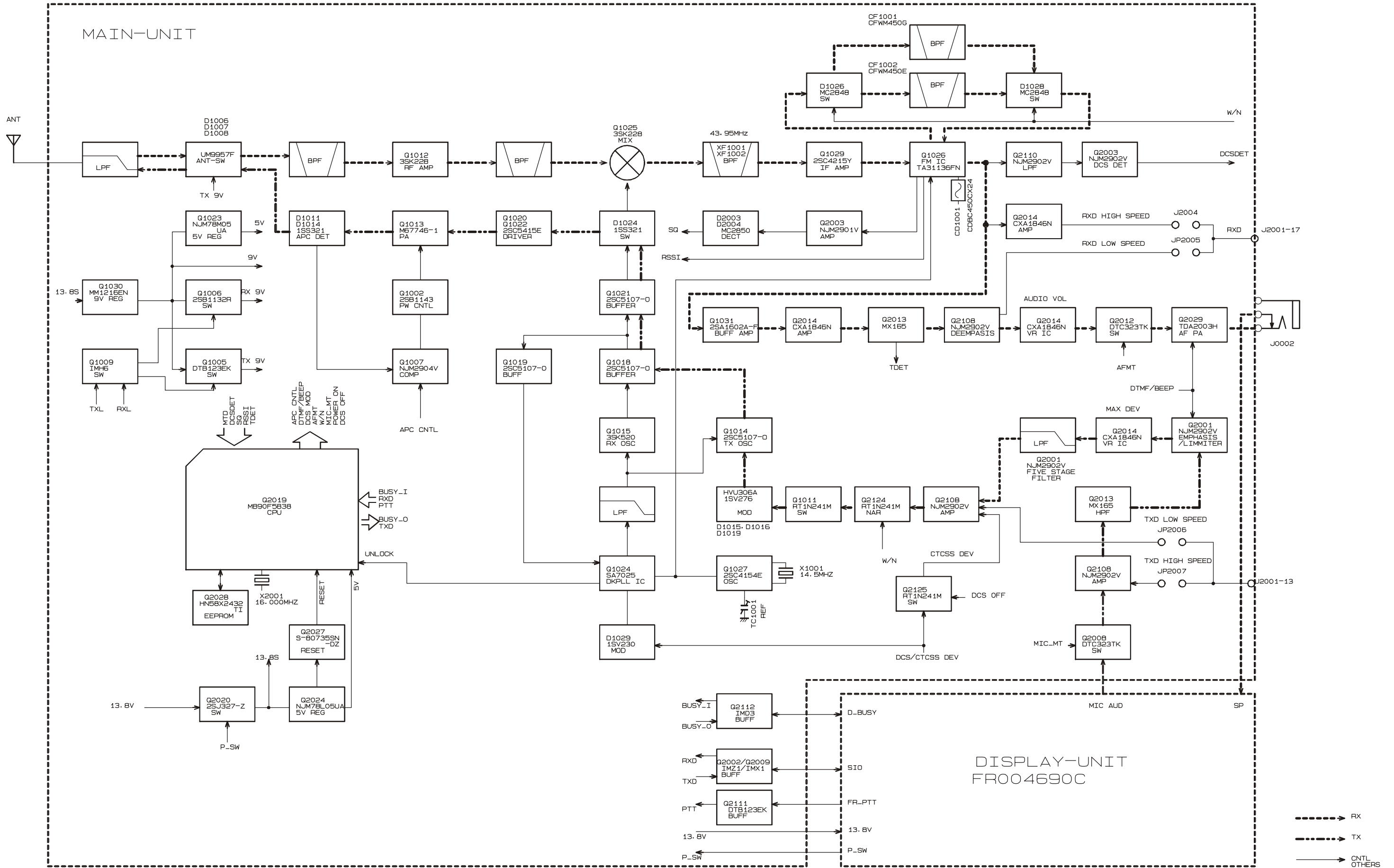

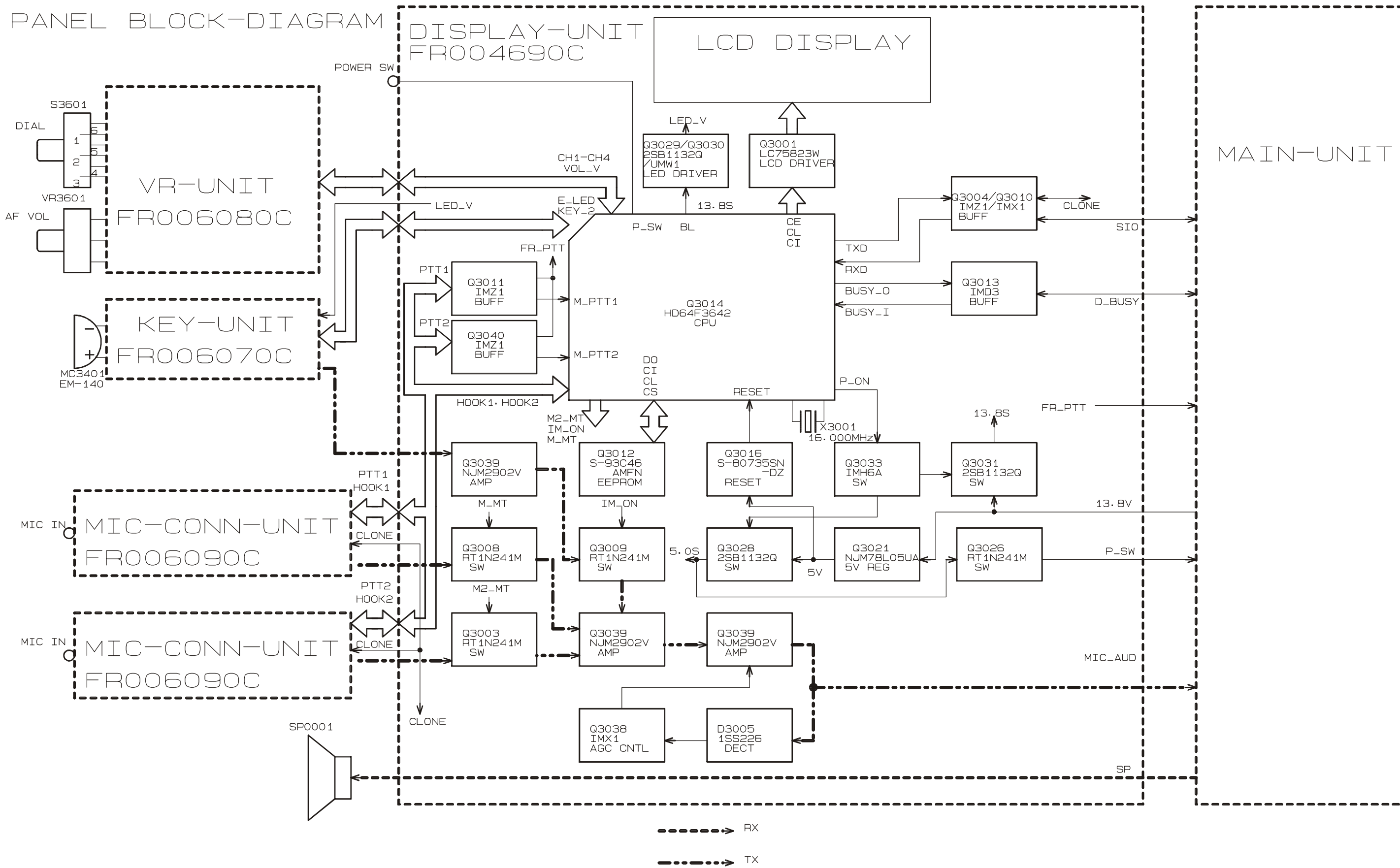

Interconnection Diagram

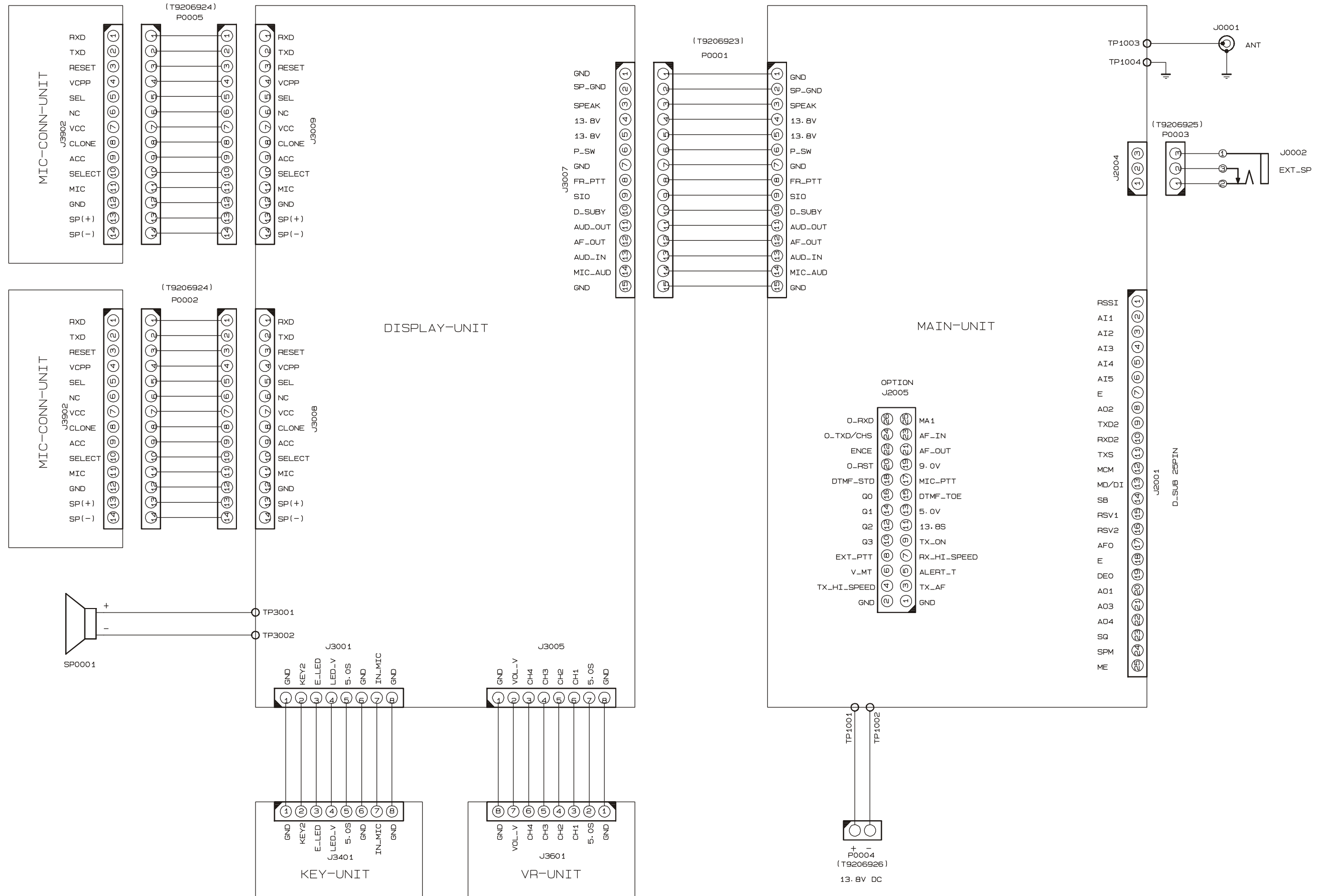

Circuit Description

Reception and transmission are switched by "RX" and "TX" lines from the microprocessor unit (MPU).

Main Receiver Signal Path

The receiver uses double-conversion superheterodyne circuitry, with a 43.95MHz 1st IF and 450 kHz 2nd IF. The 1st LO, produced by a PLL synthesizer, yields the 43.95MHz 1st IF.

The 2nd LO uses a 43.5 MHz (43.95 MHz-450 kHz) signal generated by a crystal oscillator. The 2nd mixer and other circuits use a custom IC to convert and amplify the 2nd IF, and detect FM to obtain demodulated signals.

During transmit, the PLL synthesizer oscillates at the desired frequency directly, for amplification to obtain RF power output. During transmit, voice modulation and CTCSS (or DCS) modulation are applied to this synthesizer. Transceiver functions, such as TX/RX control, PLL synthesizer settings, and channel programming, are controlled using the MPU.

Receiver

Incoming RF signals from the antenna connector are delivered to the MAIN Unit, and pass through a low-pass filter (LPF) antenna switching network consisting of coils L1001, L1002, L1003 and L1006, capacitors C1001, C1006, C1009, C1013, and C1023, and antenna switching diodes D1006, D1007 and D1008 for delivery to the receiver front end.

Signals within the frequency range of the transceiver are then passed through a varactor-tuned bandpass filter consisting of L1008, L1009 / L1024, L1025 before RF amplification by Q1012 (**3SK228**).

The amplified RF is then band-pass filtered again by varactor-tuned resonators L1018, L1019 / L1038, L1039 to ensure pure in-band input to 1st mixer Q1025 (**2SK228**).

Buffered output from the VCO Unit is amplified by Q1021 (**2SC5107**) and low-pass filtered by L1042 / L1046 and C1132 / C1139 / C1142, to provide a pure 1st local signal between 112.3 and 152.3 MHz to the 1st mixer.

The 43.95MHz 1st mixer product then passes through dual monolithic crystal filters XF1001 and XF1002 (7.5 kHz BW), and is amplified by Q1029 (**2SC4215Y**) and delivered to the input of the FM IF subsystem IC Q1026 (**TA31136FN**).

This IC contains the 2nd mixer, 2nd local oscillator, limiter amplifier, FM detector, noise amplifier, and squelch gates.

The 2nd LO in the IF-IC is produced from crystal X1001 (14.500MHz), and the 1st IF is converted to 450kHz by the 2nd mixer and stripped of unwanted components by ceramic filter CF1001 or CF1002. After passing through a limiter amplifier, the signal is demodulated by the FM detector.

Demodulated receive audio from the IF-IC is amplified by Q1031 (**2SA1602A**) / Q2014 (**CXA1846N**). After volume adjustment by the AF power amplifier Q2029 (**TDA7240AV**), the audio signal is passed to the optional headphone jack or 4-ohm loudspeaker.

PLL synthesizer

The 1st LO maintains stability from the PLL synthesizer by using a 14.500 MHz reference signal from crystal X1001. PLL synthesizer IC Q1024 (**SA7025DK**) consists of a prescaler, reference counter, swallow counter, programmable counter, a serial data input port to set these counters based on the external data, a phase comparator, and charge pump. The PLL-IC divides the 14.500 MHz reference signal by 725 using the reference counter (20.0 kHz comparison frequency). The phase detector comparison frequency to be eight times the channel spacing (2.5kHz). The VCO output is divided by the prescaler, swallow counter and programmable counter. These two signals are compared by the phase comparator and input to the charge pump. A voltage proportional to their phase difference is delivered to the low-pass filter circuit, then fed back to the VCO as a voltage with phase error, controlling and stabilizing the oscillating frequency. This synthesizer also operates as a modulator during transmit.

The RX-VCO is comprised of Q1015 (**2SK520**) and D1017, D1018, D1035, D1036 (**HVU356x4**), and oscillates between 177.950MHz and 217.950MHz according to the programmed receiving frequency. And the TX-VCO is comprised of Q1014 (**2SC5107**) and D1015, D1016, D1019 (**1SV276x3**), and oscillates between 134.000MHz and 174.000MHz according to the programmed transmit frequency. The VCO output passes through buffer amplifier Q1018 (**2SC5107**), and a portion is fed to the buffer amplifier Q1019 (**2SC5107**) of the PLL IC, and at the same time amplified by Q1021 (**2SC5107**) to obtain stable output. The VCO DC supply is regulated by Q1008 (**2SC4154E**). Synthesizer output is fed to the 1st mixer by diode switch D1024 (**1SS321**) during receive, and to drive amplifier Q1020/Q1022 (**2SC5415Ex2**) for transmit. The reference oscillator feeds the PLL synthesizer, and is com-

Circuit Description

posed of crystal X1001 (14.500 MHz), the temperature compensation circuit which includes D1033 (**MC2850**) and thermostats TH1003 and TH1002, and transmit (DCS) modulation circuit D1029 (**1SV2309**).

Transmitter

Voice audio from the microphone is delivered via the Mic (Jack) Unit to the MAIN Unit, after passing through amplifier Q3039/Q2108 (**NJM2902V**), pre-emphasis, limiter (IDC instantaneous deviation control), and LPF Q2001 (**NJM2902V**), is adjusted for optimum deviation level and delivered to the next stage.

Voice input from the microphone and CTCSS are FM-modulated to the VCO of the synthesizer, while DCS audio is modulated by the reference frequency oscillator of the synthesizer.

Synthesizer output, after passing through diode switch D1024 (**1SS321**), is amplified by driver Q1020 / Q1022 (**2SC5415Ex2**) and power module Q1013 (**M67746**) to obtain full RF output. The RF energy then passes through antenna switch D1007 / D1008 and a low-pass filter circuit and finally to the antenna connector.

RF output power from the final amplifier is sampled by CM coupler and is rectified by D1011, D1014 (**HSM88ASx2**). The resulting DC is fed through Automatic Power Controller Q1007 (**NJM2904V**), Q1001 (**2SC4154E**), Q1002 (**2SB1143S**) to transmitter RF amplifier and thus the power output.

Generation of spurious products by the transmitter is minimized by the fundamental carrier frequency being equal to the final transmitting frequency, modulated directly in the transmit VCO. Additional harmonic suppression is provided by a low-pass filter consisting of L1002, L1003, L1007, L1012 and C1006, C1009, C1013, C1023, C1033, C1037 and C1046, resulting in more than 60dB of harmonic suppression prior to delivery to the RF energy to the antenna.

DCS Demodulator

DCS signals are demodulated on the MAIN-UNIT, and are applied to low-pass filter Q2110 (**NJM2902V**), as well as the limiter comparator Q2110.

CTCSS encoder/decoder

The CTCSS code is generation and encoding by MPU IC Q2019 (**MB90F583B**).

Demodulation and detection of the CTCSS tones are carried out by IC Q2013 (**MX165C**).

MPU

Operation is controlled by 16-bit MPU IC Q2019 (**MB90F583B**). The system clock uses a 16.000 MHz crystal for a time base. IC Q2027 (**S-80735SN**) resets the MPU when the power is on, and monitors the voltage of the regulated 5V power supply line.

EEPROM

The EEPROM retains TX and RX data for all memory channels and CTCSS data, DCS data, prescaler dividing, and REF oscillator data (internal/external).

The VX-4000 has been carefully aligned at the factory for the specified performance across the frequency range specified for each version.

Realignment should therefore not be necessary except in the event of a component failure, or alteration of version. All component replacement and service should be performed only by an authorized **VERTEX STANDARD** representative, or the warranty policy may be voided.

The following procedures cover the sometimes critical and tedious adjustments that are not normally required once the transceiver has left the factory. However, if damage occurs and some parts are replaced, realignment may be required. If a sudden problem occurs during normal operation, it is likely due to component failure; realignment should not be done until after the faulty component has been replaced.

We recommend that servicing be performed only by authorized **VERTEX STANDARD** service technicians who are experienced with the circuitry and fully equipped for repair and alignment. Therefore, if a fault is suspected, contact the dealer from whom the transceiver was purchased for instructions regarding repair.

Authorized **VERTEX STANDARD** service technicians realign all circuits and make complete performance checks to ensure compliance with factory specifications after replacing any faulty components. Those who do undertake any of the following alignments are cautioned to proceed at their own risk. Problems caused by unauthorized attempts at realignment are not covered by the warranty policy. Also, **VERTEX STANDARD** must reserve the right to change circuits and alignment procedures in the interest of improved performance, without notifying owners. Under no circumstances should any alignment be attempted unless the normal function and operation of the transceiver are clearly understood, the cause of the malfunction has been clearly pinpointed and any faulty components replaced, and the need for realignment determined to be absolutely necessary. The following test equipment (and thorough familiarity with its correct use) is necessary for complete realignment. Correction of problems caused by misalignment resulting from use of improper test equipment is not covered under the warranty policy.

While most steps do not require all of the equipment listed, the interactions of some adjustments may require that more complex adjustments be performed afterwards.

Do not attempt to perform only a single step unless it is clearly isolated electrically from all other steps. Have all test equipment ready before beginning, and follow all of the steps in a section in the order presented.

Required Test Equipment

- RF signal generator: calibrated output level at 1000 MHz
- Deviation Meter (linear detector)
- AF Millivoltmeter
- SINAD Meter
- Inline Wattmeter with 5% accuracy at 1000 MHz
- Regulated DC Power Supply: adjustable from 10 to 17 VDC, 15A
- 50-ohm Non-reactive Dummy Load: 100 W at 1000 MHz
- Frequency Counter: >0.1 ppm accuracy at 1000 MHz
- AF Signal Generator
- DC Voltmeter: high impedance
- RF Sampling Coupler(attenuation pad)
- AF Dummy Load: 4 ohm, 20W
- Oscilloscope
- Spectrum Analyzer
- IBM PC/compatible computer w/ VERTEX STANDARD CT-71 programming cable and CE35 channel programming editor.

Alignment Preparation & Precautions

A dummy load and inline wattmeter must be connected to the main antenna jack in all procedures that call for transmission, except where specified otherwise. Correct alignment is not possible with an antenna. After completing one step, read the following step to determine whether the same test equipment will be required. If not, remove the test equipment (except dummy load and wattmeter, if connected) before proceeding.

Correct alignment requires that the ambient temperature be the same as that of the transceiver and test equipment, and that this temperature be held constant between 68 ~ 86°F (20 ~ 30°C). When the transceiver is brought into the shop from hot or cold air it should be allowed some time for thermal equalization with the environment before alignment. If possible, alignments should be made with oscillator shields and circuit boards firmly affixed in place. Also, the test equipment must be thoroughly warmed up before beginning.

Alignment

Before beginning, connect the transceiver and PC using the CT-71 programming cable as described in the EEPROM Programming chapter, and download the EEPROM data from the transceiver to the computer.

Store this data in a disk file so that it can be saved and retrieved later. Using the table below, program the channel, CTCSS, and DCS alignment settings for your transceiver version. Upload this file to the transceiver.

Note: Signal levels in dB referred to in this procedure are based on $0 \text{ dB}\mu = 0.5 \mu\text{V}$ (closed circuit).

Caution: Do not connect this line to ground, and be certain that the speaker has adequate capability to handle the audio output from the radio.

Because of the bridge audio amplifier circuit used in the radio, it is necessary to construct and use a simple audio load test adapter as shown in the schematic diagram above, when conducting receiver alignment steps.

Alignment Channel Frequencies

VHF TYPE A

Channel	Frequency (simplex)	CTCSS Encode	DCS Encode	Narrow/wide
CH1	134.01 MHz	None	None	Wide
CH2	147.01 MHz	None	None	Wide
CH3	159.99 MHz	None	None	Wide
CH4	134.01 MHz	None	None	Narrow
CH5	147.01 MHz	None	None	Narrow
CH6	159.99 MHz	None	None	Narrow
CH7	147.01 MHz	151.4 Hz	None	Wide
CH8	147.01 MHz	None	023	Wide
CH9	147.01 MHz	151.4 Hz	None	Narrow
CH10	147.01 MHz	None	023	Narrow

VHF TYPE C

Channel	Frequency (simplex)	CTCSS Encode	DCS Encode	Narrow/wide
CH1	148.01 MHz	None	None	Wide
CH2	161.01 MHz	None	None	Wide
CH3	173.99 MHz	None	None	Wide
CH4	148.01 MHz	None	None	Narrow
CH5	161.01 MHz	None	None	Narrow
CH6	173.99 MHz	None	None	Narrow
CH7	161.01 MHz	151.4 Hz	None	Wide
CH8	161.01 MHz	None	023	Wide
CH9	161.01 MHz	151.4 Hz	None	Narrow
CH10	161.01 MHz	None	023	Narrow

PLL & Transmitter

Set up the test equipment as shown for transmitter alignment.

Maintain the supply voltage at 13.8 V DC for all steps.

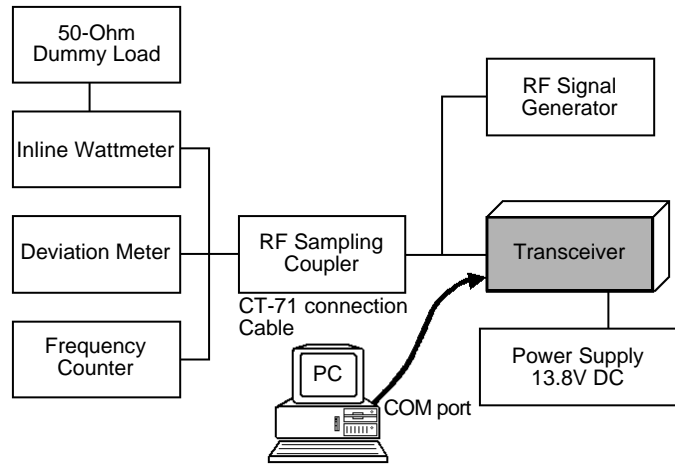

PLL VCV

- Connect the positive lead of the DC voltmeter to the test point **TP1007** (VCV) on the Main Unit, as indicated in the figure, and the negative lead to chassis ground.
- Set the transceiver to the high band edge frequency channel, then adjust **L1021** on the Unit for 4.2 V (VHF-A), 4.3 V (VHF-C) on the voltmeter.
- Key the transmitter, and adjust **L1022** on the Unit for 4.2 V (VHF-A), 4.3 V (VHF-C) on the voltmeter.
- Next select to the low edge frequency channel and confirm 0.8 V on the voltmeter.
- Key the transmitter, and confirm 1.0 V on the voltmeter.

PLL Reference Frequency

With the wattmeter, dummy load and frequency counter connected to the antenna jack, and select band center frequency channel, key the transmitter (Low power level) and adjust **TC1001** on the Main Unit, if necessary, so the counter frequency is within 100 Hz of the channel center frequency for the transceiver version.

Transmitter Output Power

The following transmitter parameters can be adjusted from the computer by utilizing the Alignment Software. Refer to the onboard help of the Alignment Software Manual for details.

HIGH Power $50 \pm 1 \text{ W}$
LOW Power $25 \pm 0.5 \text{ W}$

Transmitter Deviation

The following modulation parameters can be adjusted from the computer by utilizing the Alignment Software. Refer to the onboard help of the Alignment Software Manual for details.

Microphone Audio Modulation Level

4.3 kHz \pm 0.1 kHz

CTCSS Modulation Level

0.75 kHz \pm 0.1 kHz

DCS Modulation Level

0.75 kHz \pm 0.1 kHz

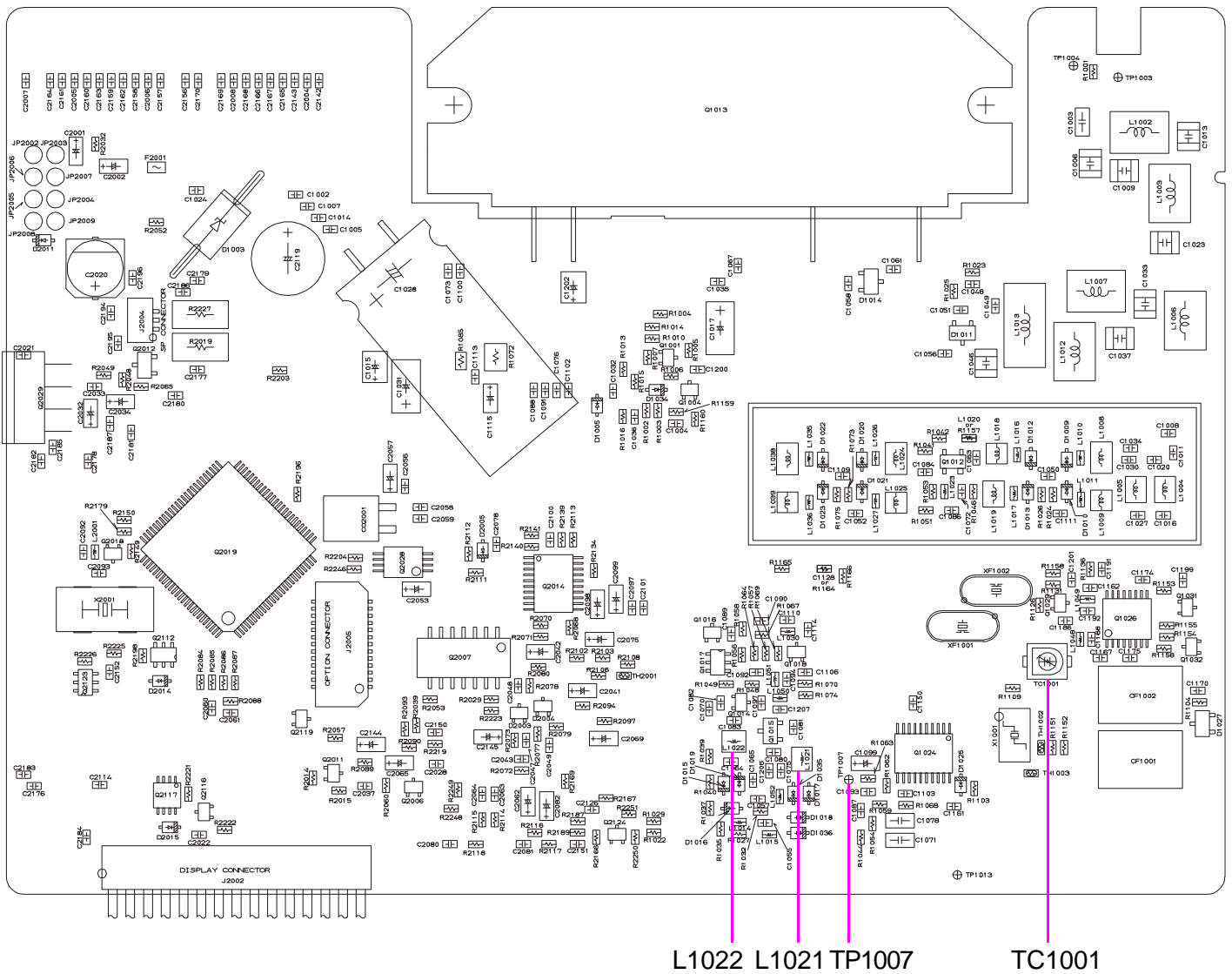

Alignment

Receiver

The sensitivity parameters can be adjusted from the computer by utilizing the Alignment Software. Refer to the onboard help of the Alignment Software Manual for details.

- Set up the test equipment as shown for receiver alignment, and install the audio test adapter.

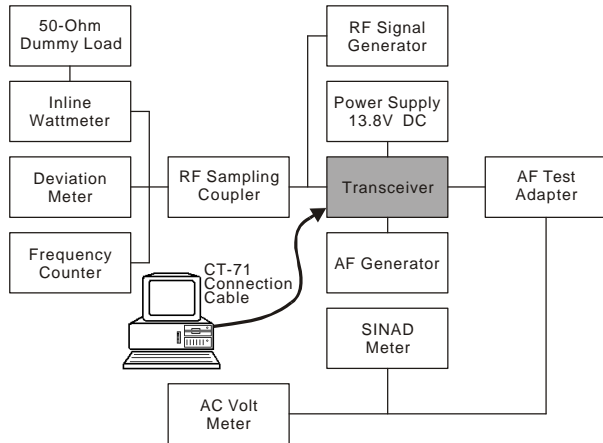

- With the transceiver set to the band center frequency channel, and with the RF signal generator tuned to the same frequency, set the generator for ± 3.0 kHz deviation (for 25 kHz steps) with 1 kHz tone modulation, and set the output level for $1\mu\text{V}$ at the antenna jack.
- Adjust (by control commands from the computer) the receiver front-end tuning for optimum SINAD, reducing signal generator output level as necessary for proper meter deflection.
- After the previous step, the final signal generator level should be less than $-8\text{ dB}\mu$ (for wide) or $-6\text{ dB}\mu$ (for narrow) for 12dB SINAD.

Squelch Threshold

The squelch parameters can also be adjusted from the computer by utilizing the Alignment Software. Refer to the onboard help of the Alignment Software Manual for details.

- Select the band center frequency channel, and with the RF signal generator turned to the same frequency, set the generator for ± 3.0 kHz deviation with 1 kHz tone modulation, and set the output level for $-6\text{ dB}\mu$ (for wide) or $-4\text{ dB}\mu$ (for narrow) at the antenna jack.
- Adjust the squelch threshold level (by control commands from the computer) such that the squelch just closes at this signal input level (the BUSY LED will turn off).

Circuit Diagram

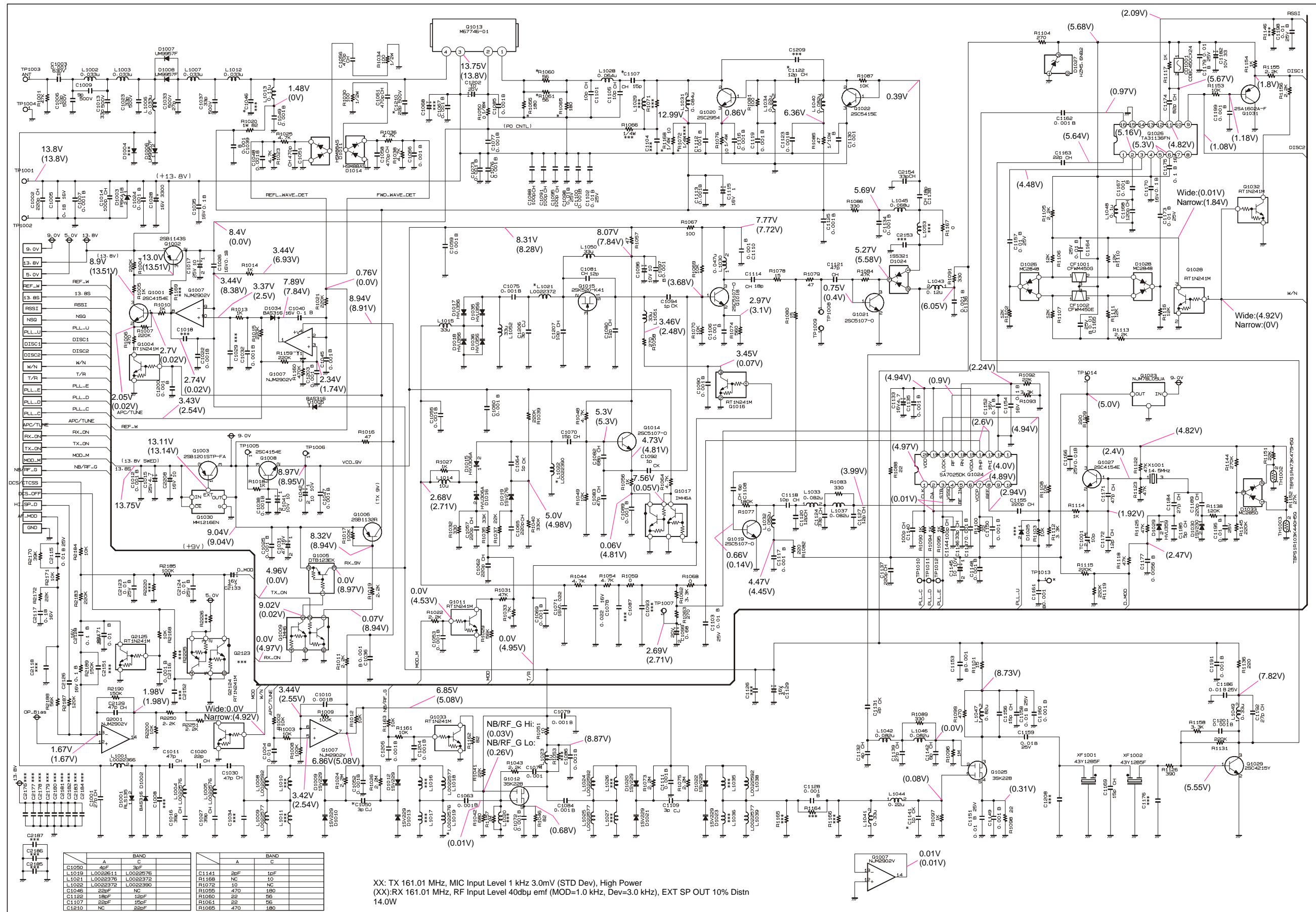

XX: TX 161.01 MHz, MIC Input Level 1 kHz 3.0mV (STD Dev), High Power
 (XX):RX 161.01 MHz, RF Input Level 40dbm emf (MOD=1.0 kHz, Dev=3.0 kHz), EXT SP OUT 10% Distn
 14.0V

MAIN Unit (Lot. 1~)

Parts Layout

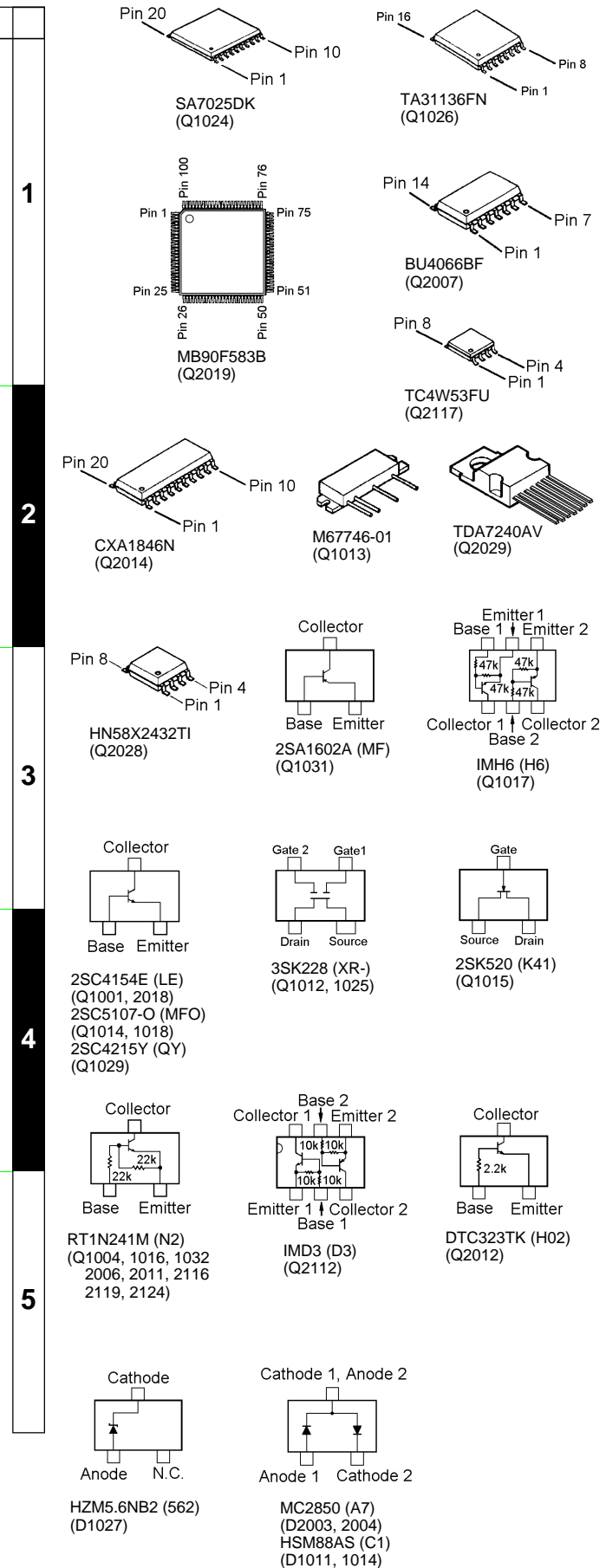
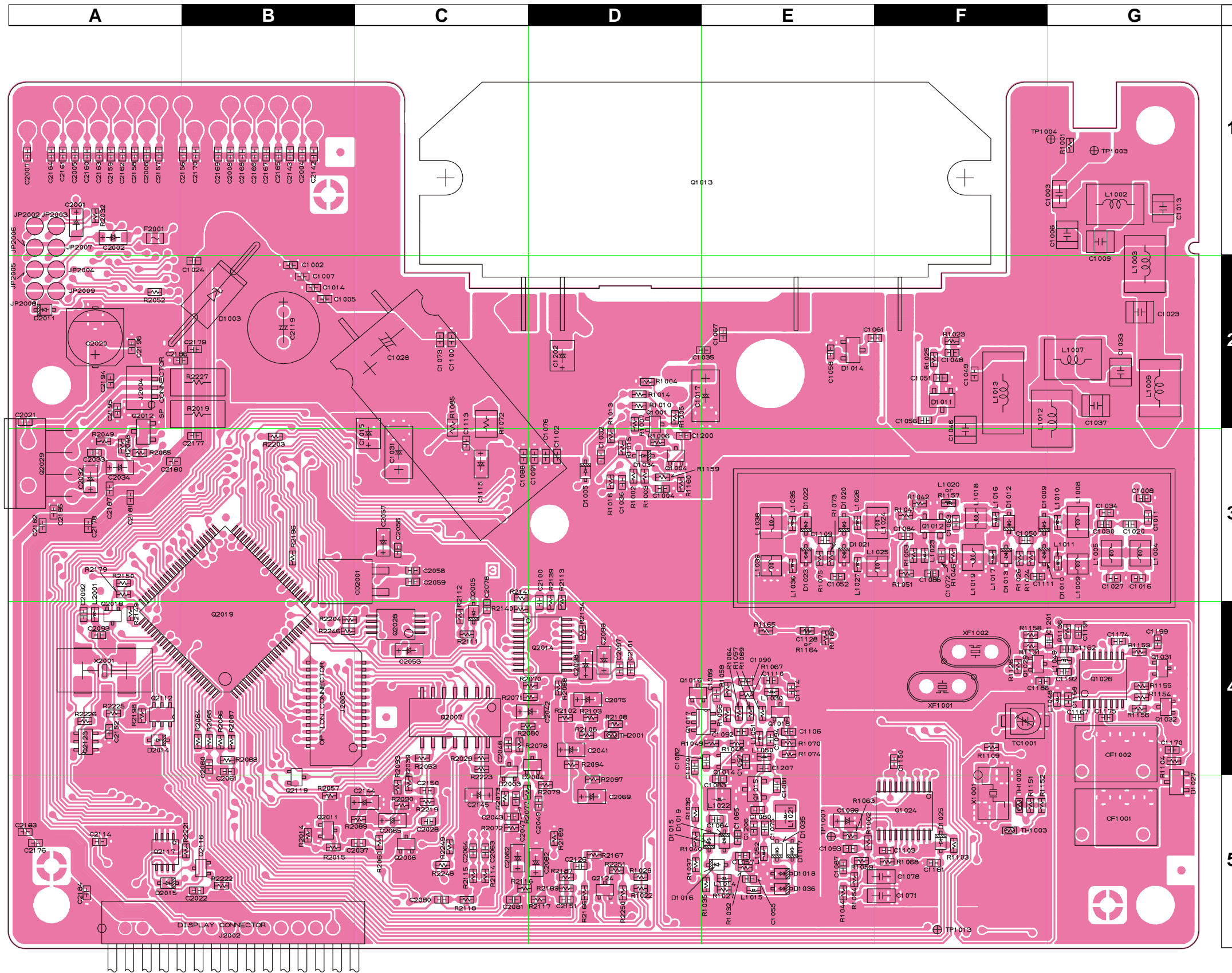

Side A

Circuit Diagram

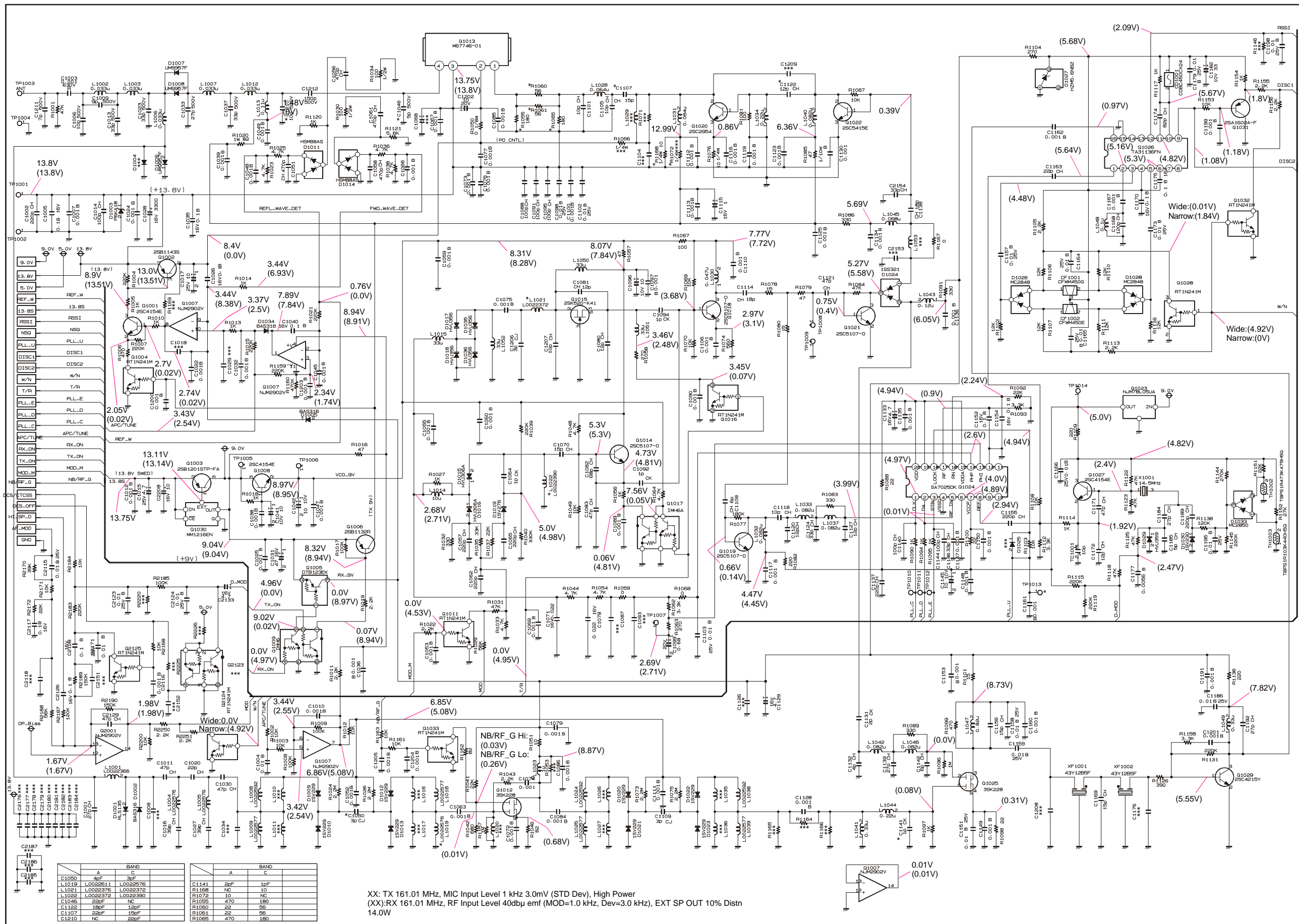

C	A		BAND	
	Value	Code	Value	Code
C1050	40F	40F		
L1019	L0022511	L0022511		
L1021	L0022576	L0022576		
L1022	L0022372	L0022372		
L1023	L0022390	L0022390		
C1046	220F	NC		
C1122	180F	120F		
C1117	20F	150F		
C1210	NC	20F		
C	A		BAND	
	Value	Code	Value	Code
C1141	20P	10P		
R1198	NC	10		
R1078	10	NC		
R1055	470	180		
R1050	20	95		
R1051	20	95		
R1055	470	180		

MAIN Unit (Lot. 4~)

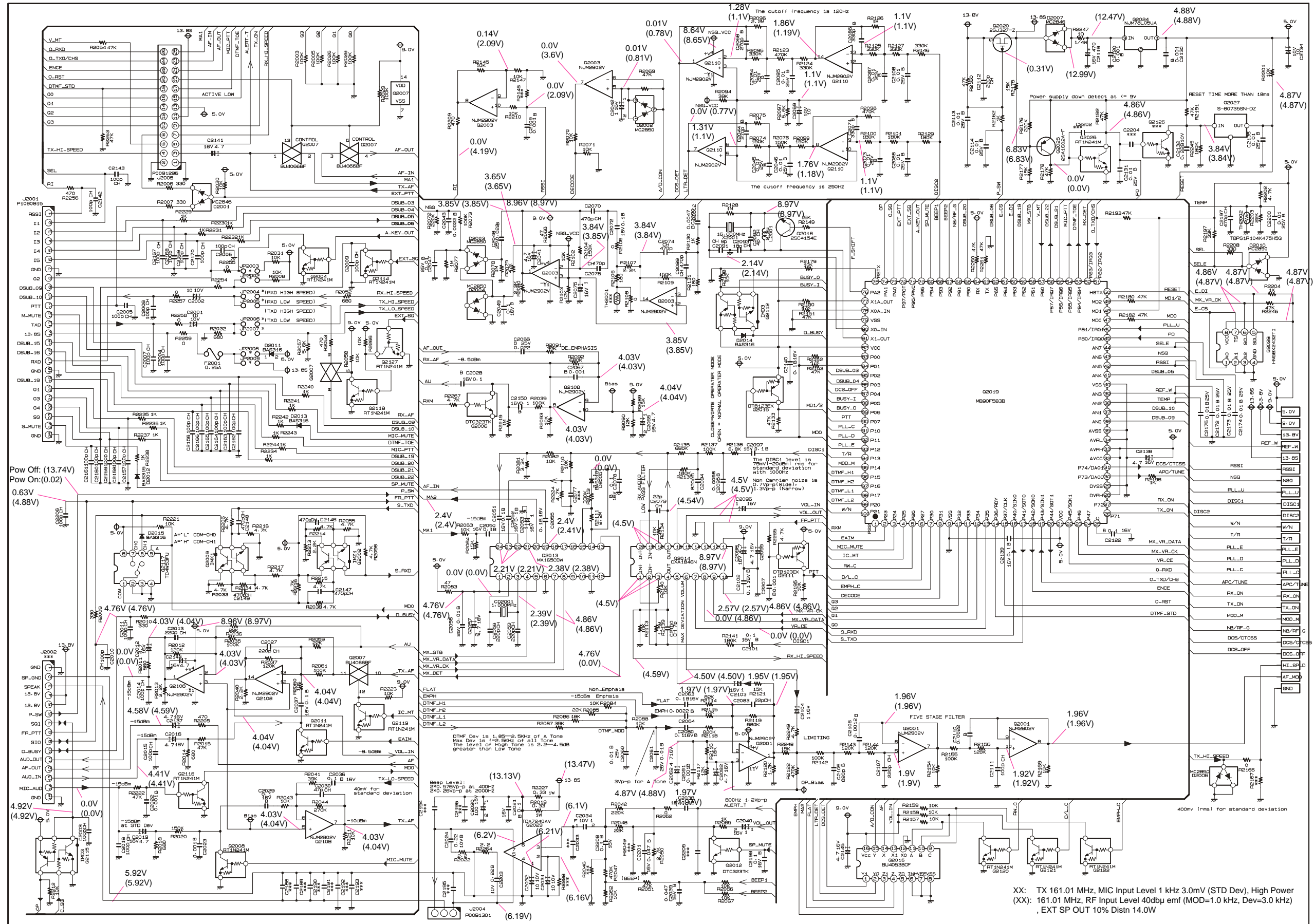

MAIN Unit (Lot. 4~)

Parts Layout

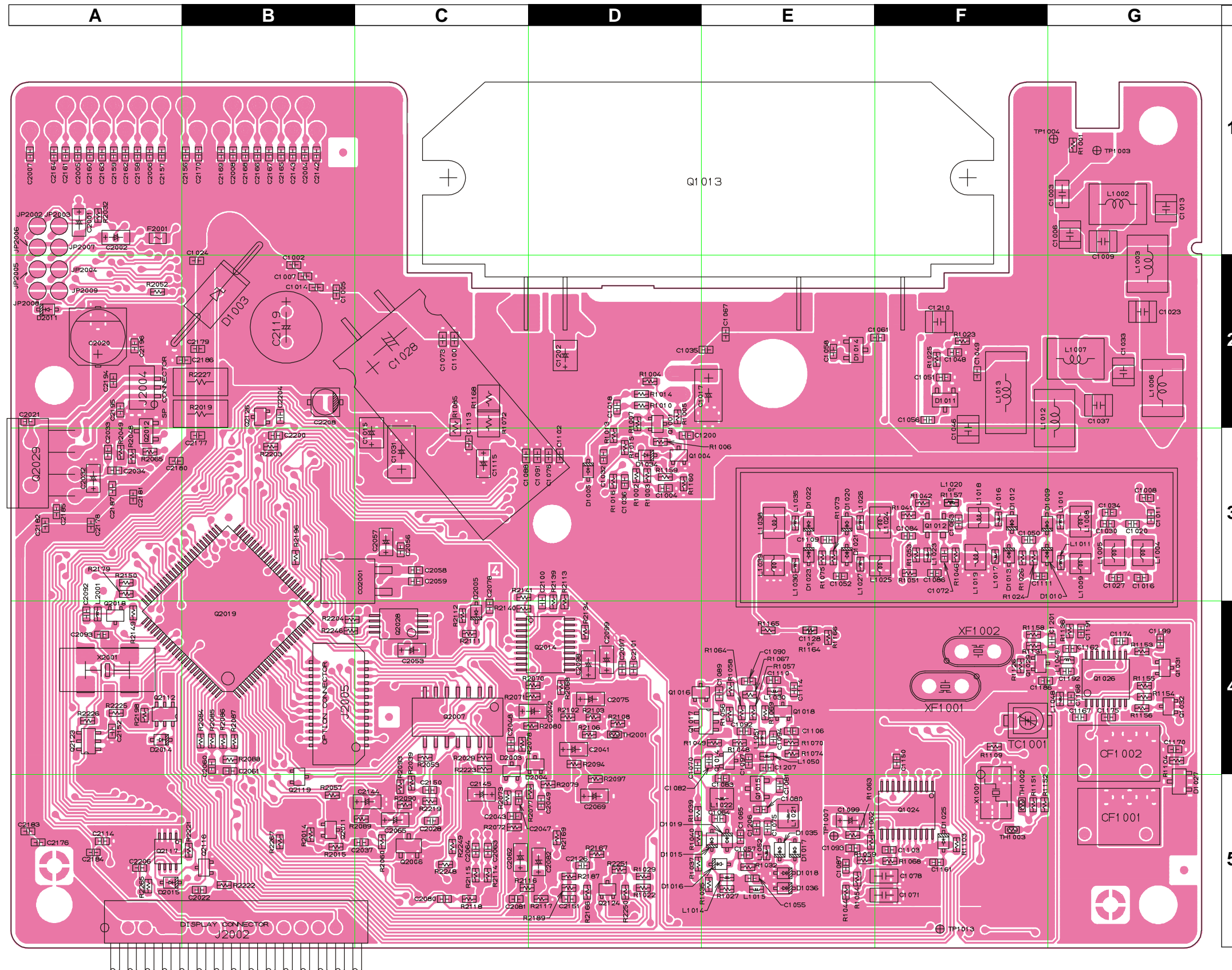

Side A

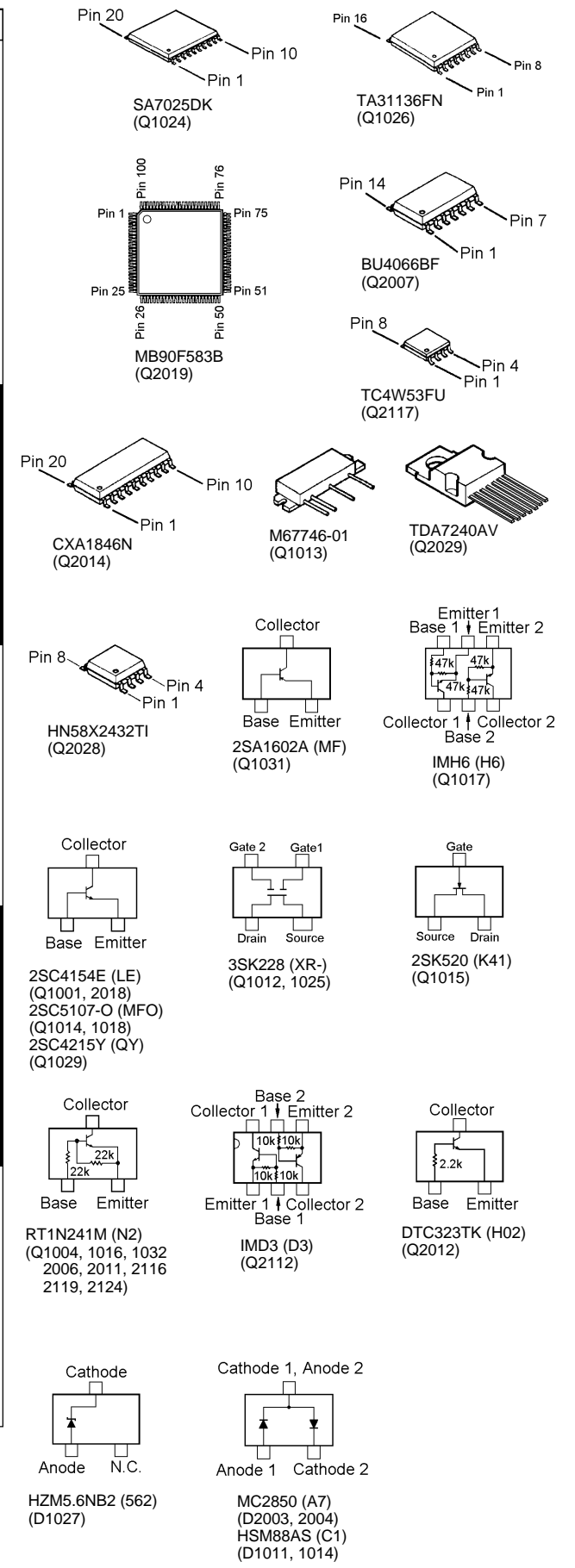

MAIN Unit (Lot. 4~)

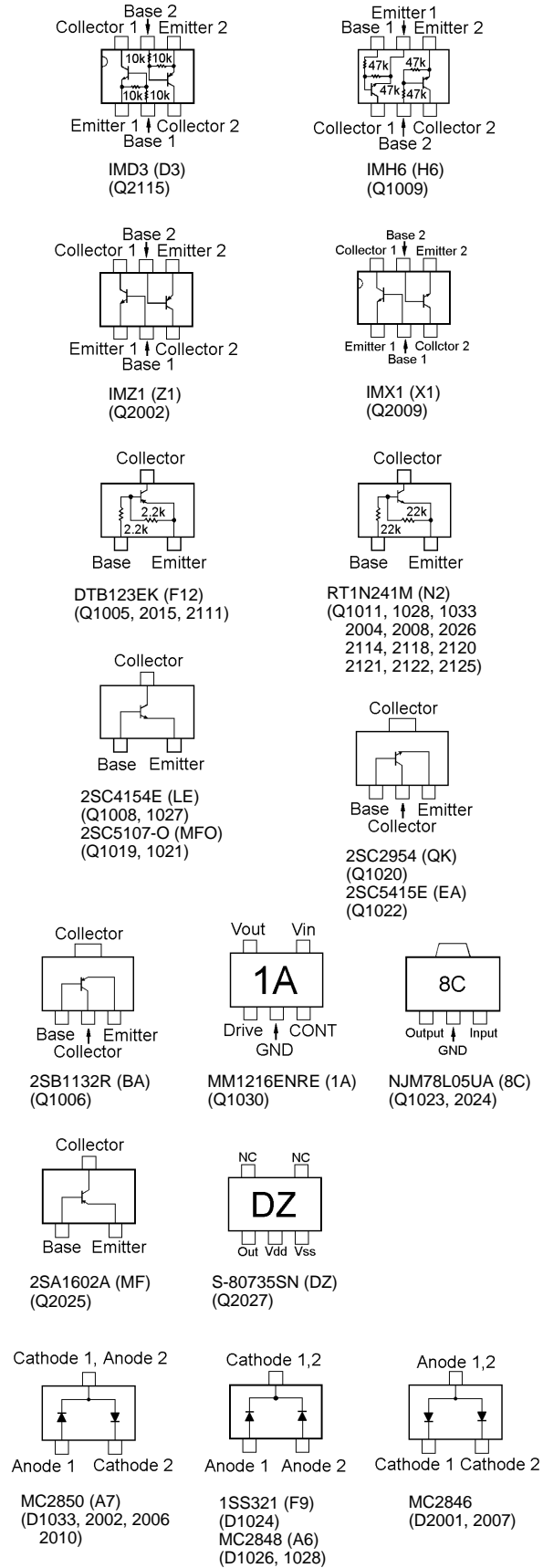
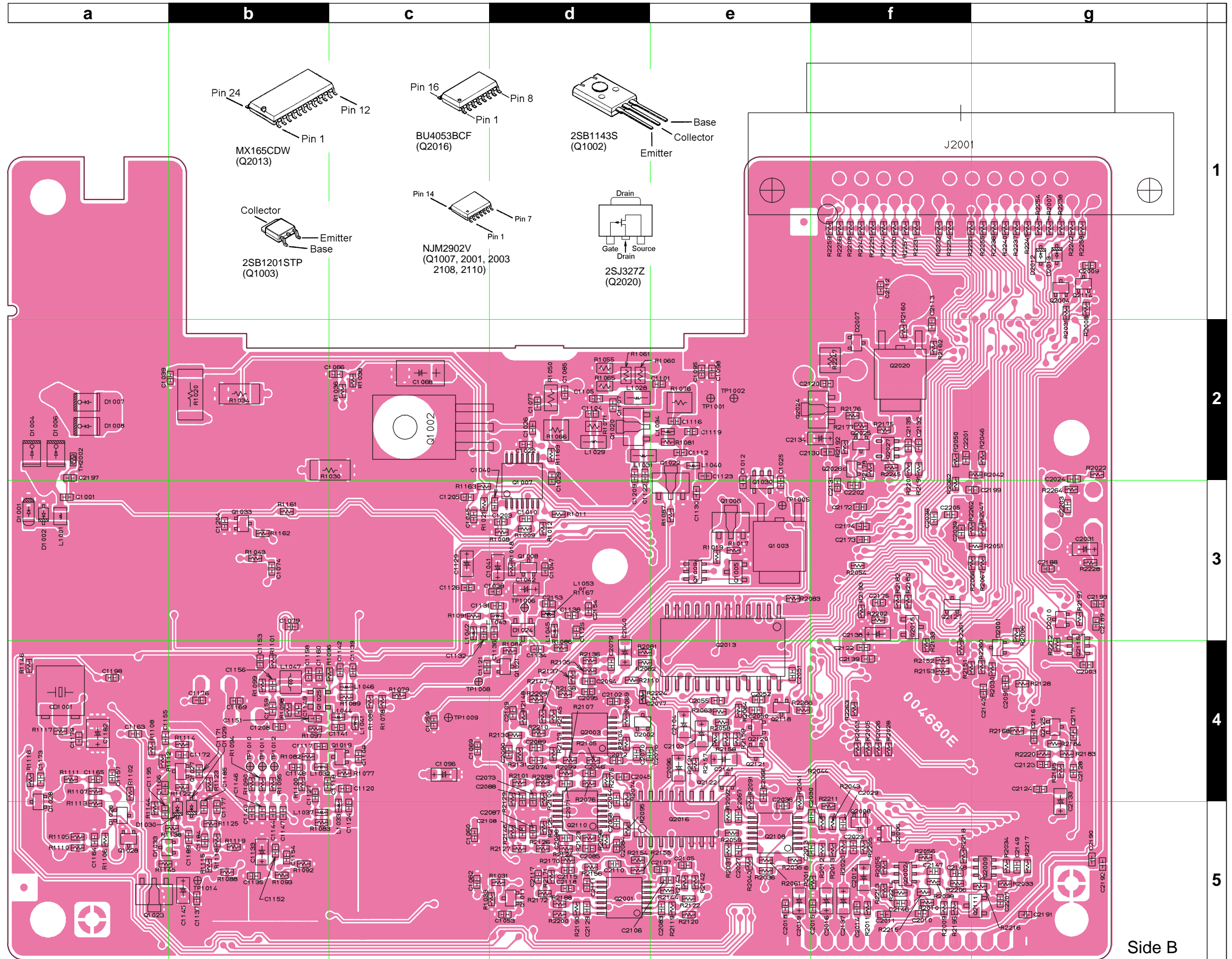

Parts List

REF.	DESCRIPTION	VALUE	WV	TOL.	MFR'S DESIG	VXSTD P/N	VERS.	LOT.	SIDE	LAY ADR.
*** MAIN UNIT ***										
PCB with Components						CS1728001	VERSION C			
PCB with Components						CS1728002	VERSION A			
Printed Circuit Board						FR004680D		1-		
Printed Circuit Board						FR004680E		4-		
C 1001	CHIP CAP.	27pF	50V	CH	GRM39CH270J50PT	K22174221		1-	B	a3
C 1002	CHIP CAP.	220pF	50V	CH	GRM39CH221J50PT	K22174243		1-	A	B2
C 1003	CHIP CAP.	0.001uF	630V	R	GHM1030R102K630PT	K22281801		1-	A	G1
C 1004	CHIP CAP.	0.01uF	50V	B	GRM39B103M50PT	K22174823		1-	A	D3
C 1005	CHIP CAP.	0.1uF	16V	B	GRM39B104K16PT	K22124805		1-	A	B2
C 1006	FILM CAP.	10pF	500V		UC232H0100D-T	K33279019		1-	A	G1
C 1007	CHIP CAP.	0.001uF	50V	B	GRM39B102K50PT	K22174821		1-	A	B2
C 1009	FILM CAP.	9pF	500V		UC232H0090D-T	K33279047		1-	A	G1
C 1010	CHIP CAP.	0.001uF	50V	B	GRM39B102K50PT	K22174821		1-	B	d3
C 1011	CHIP CAP.	47pF	50V	CH	GRM39CH470J50PT	K22174227		1-	A	G3
C 1012	CHIP CAP.	0.001uF	50V	B	GRM39B102K50PT	K22174821		1-	B	e3
C 1013	FILM CAP.	33pF	500V		UC232H0330J-T	K33279024		1-	A	G1
C 1014	CHIP CAP.	100pF	50V	CH	GRM39CH101J50PT	K22174235		1-	A	B2
C 1015	CHIP TA.CAP.	4.7uF	16V		TEMSVB21C475M-8R	K78120016		1-	A	C3
C 1015	CHIP TA.CAP.	4.7uF	25V		TEMSVB21E475M-8R	K78140019		3-	A	C3
C 1016	CHIP CAP.	39pF	50V	CH	GRM39CH390J50PT	K22174225		1-	A	G3
C 1017	CHIP TA.CAP.	10uF	25V		TEMSVC1E106M12R	K78140021		1-	A	E2
C 1020	CHIP CAP.	22pF	50V	CH	GRM39CH220J50PT	K22174219		1-	A	G3
C 1022	CHIP CAP.	0.001uF	50V	B	GRM39B102K50PT	K22174821		1-	B	d2
C 1023	FILM CAP.	33pF	500V		UC232H0330J-T	K33279024		1-	A	G2
C 1024	CHIP CAP.	0.001uF	50V	B	GRM39B102K50PT	K22174821		1-	A	B2
C 1025	CHIP CAP.	0.001uF	50V	B	GRM39B102K50PT	K22174821		1-	B	e3
C 1026	CHIP CAP.	0.1uF	16V	B	GRM39B104K16PT	K22124805		1-	B	d2
C 1027	CHIP CAP.	39pF	50V	CH	GRM39CH390J50PT	K22174225		1-	A	G3
C 1028	AL.ELECTRO.CAP.	3300uF	16V		RE3-16V332M 3300UF	K40129065		1-	A	C2
C 1030	CHIP CAP.	47pF	50V	CH	GRM39CH470J50PT	K22174227		1-	A	G3
C 1031	CHIP TA.CAP.	68uF	10V		TEMSVC1A686M12R	K78100048		1-	A	C3
C 1031	CHIP TA.CAP.	47uF	16V		TEMSVC1C476M12R	K78120057		4-	A	C3
C 1032	CHIP CAP.	0.001uF	50V	B	GRM39B102K50PT	K22174821		1-	A	D3
C 1033	FILM CAP.	27pF	500V		UC232H0270J-T	K33279023		1-	A	G2
C 1035	CHIP CAP.	0.1uF	16V	B	GRM39B104K16PT	K22124805		1-	A	E2
C 1036	CHIP CAP.	0.001uF	50V	B	GRM39B102K50PT	K22174821		1-	A	D3
C 1037	FILM CAP.	33pF	500V		UC232H0330J-T	K33279024		1-	A	G2
C 1038	CHIP CAP.	0.001uF	50V	B	GRM39B102K50PT	K22174821		1-	B	d3
C 1039	CHIP CAP.	0.001uF	50V	B	GRM39B102K50PT	K22174821		1-	B	b2
C 1040	CHIP CAP.	0.1uF	16V	B	GRM39B104K16PT	K22124805		1-	B	d3
C 1041	CHIP TA.CAP.	10uF	10V		TEMSVA1A106M-8R	K78100028		1-	B	d3
C 1042	CHIP TA.CAP.	10uF	10V		TEMSVA1A106M-8R	K78100028		1-	B	d3
C 1045	CHIP CAP.	0.001uF	50V	B	GRM39B102K50PT	K22174821		1-	B	c3
C 1046	CHIP CAP.	22pF	500V	CH	GRM42-6CH220J500PT	K22271221		1	A	F3
C 1046	CHIP CAP.	5pF	500V	CH	GRM42-6CH050C500PT	K22271208		2-3	A	F3
C 1046	FILM CAP.	22pF	500V		UC232H0220J-T	K33279021	VERSION A	4-	A	F3
C 1046	FILM CAP.	10pF	500V		UC232H0100D-T	K33279019	VERSION C	4-	A	F3
C 1047	CHIP CAP.	0.001uF	50V	B	GRM39B102K50PT	K22174821		1-	B	d3
C 1048	CHIP CAP.	0.001uF	50V	B	GRM39B102K50PT	K22174821		1-	A	F2
C 1049	CHIP CAP.	0.001uF	50V	B	GRM39B102K50PT	K22174821		1-	A	F2
C 1050	CHIP CAP.	3pF	50V	CJ	GRM39CJ030C50PT	K22174204		1-3	A	F3
C 1050	CHIP CAP.	4pF	50V	CH	GRM39CH040C50PT	K22174205	VERSION A	4-	A	F3
C 1050	CHIP CAP.	3pF	50V	CJ	GRM39CJ030C50PT	K22174204	VERSION C	4-	A	F3
C 1051	CHIP CAP.	470pF	50V	CH	GRM39CH471J50PT	K22174249		1-	A	F2
C 1052	CHIP CAP.	0.001uF	50V	B	GRM39B102K50PT	K22174821		1-	A	E3
C 1053	CHIP CAP.	0.001uF	50V	B	GRM39B102K50PT	K22174821		1-	B	d5
C 1055	CHIP CAP.	0.001uF	50V	B	GRM39B102K50PT	K22174821		1-	A	E5
C 1056	CHIP CAP.	470pF	50V	CH	GRM39CH471J50PT	K22174249		1-	A	F2
C 1057	CHIP CAP.	220pF	50V	CH	GRM39CH221J50PT	K22174243		1-	A	E5

MAIN Unit

REF.	DESCRIPTION	VALUE	WV	TOL.	MFR'S DESIG	VXSTD P/N	VERS.	LOT.	SIDE	LAY ADR.
C 1058	CHIP CAP.	470pF	50V	CH	GRM39CH471J50PT	K22174249		1-	A	E2
C 1059	CHIP CAP.	0.001uF	50V	B	GRM39B102K50PT	K22174821		1-	B	c4
C 1060	CHIP CAP.	0.001uF	50V	B	GRM39B102K50PT	K22174821		1-	B	c5
C 1061	CHIP CAP.	470pF	50V	CH	GRM39CH471J50PT	K22174249		1-	A	F2
C 1062	CHIP CAP.	220pF	50V	CH	GRM39CH221J50PT	K22174243		1-	B	c5
C 1063	CHIP CAP.	0.001uF	50V	B	GRM39B102K50PT	K22174821		1-	A	F3
C 1064	CHIP CAP.	1pF	50V	CK	GRM39CK010C50PT	K22174202		1-	A	E5
C 1065	CHIP CAP.	220pF	50V	CH	GRM39CH221J50PT	K22174243		1-	A	E5
C 1066	CHIP CAP.	0.001uF	50V	B	GRM39B102K50PT	K22174821		1-	B	c2
C 1067	CHIP CAP.	0.001uF	50V	B	GRM39B102K50PT	K22174821		1-	A	E2
C 1069	CHIP CAP.	0.001uF	50V	B	GRM39B102K50PT	K22174821		1-	B	c4
C 1070	CHIP CAP.	15pF	50V	CH	GRM39CH150J50PT	K22174215		1-	A	D4
C 1071	FILM CAP.	0.022uF	16V		ECHU1C223JB5	K57120011		1-	A	F5
C 1072	CHIP CAP.	0.001uF	50V	B	GRM39B102K50PT	K22174821		1-	A	F3
C 1073	CHIP CAP.	0.001uF	50V	B	GRM39B102K50PT	K22174821		1-	A	C2
C 1074	CHIP CAP.	0.001uF	50V	B	GRM39B102K50PT	K22174821		1-	B	b3
C 1075	CHIP CAP.	0.001uF	50V	B	GRM39B102K50PT	K22174821		1-	A	E5
C 1076	CHIP CAP.	0.001uF	50V	B	GRM39B102K50PT	K22174821		1-	A	D3
C 1077	CHIP CAP.	0.001uF	50V	B	GRM39B102K50PT	K22174821		1-	B	d2
C 1078	FILM CAP.	0.022uF	16V		ECHU1C223JB5	K57120011		1-	A	F5
C 1079	CHIP CAP.	0.001uF	50V	B	GRM39B102K50PT	K22174821		1-	B	b3
C 1080	CHIP CAP.	12pF	50V	CH	GRM39CH120J50PT	K22174213		1-	A	E5
C 1081	CHIP CAP.	12pF	50V	CH	GRM39CH120J50PT	K22174213		1-	A	E5
C 1082	CHIP CAP.	68pF	50V	CH	GRM39CH680J50PT	K22174231		1-	A	E4
C 1083	CHIP CAP.	47pF	50V	CH	GRM39CH470J50PT	K22174227		1-	A	E5
C 1084	CHIP CAP.	0.001uF	50V	B	GRM39B102K50PT	K22174821		1-	A	F3
C 1085	CHIP CAP.	0.001uF	50V	B	GRM39B102K50PT	K22174821		1-	B	d2
C 1086	CHIP CAP.	0.001uF	50V	B	GRM39B102K50PT	K22174821		1-	A	F3
C 1088	CHIP CAP.	100pF	50V	CH	GRM39CH101J50PT	K22174235		1-	A	C3
C 1089	CHIP CAP.	0.001uF	50V	B	GRM39B102K50PT	K22174821		1-	A	E4
C 1090	CHIP CAP.	0.001uF	50V	B	GRM39B102K50PT	K22174821		1-	A	E4
C 1091	CHIP CAP.	100pF	50V	CH	GRM39CH101J50PT	K22174235		1-	A	D3
C 1092	CHIP CAP.	1pF	50V	CK	GRM39CK010C50PT	K22174202		1-	A	E4
C 1094	CHIP CAP.	1pF	50V	CK	GRM39CK010C50PT	K22174202		1-	A	E4
C 1095	CHIP CAP.	100pF	50V	CH	GRM39CH101J50PT	K22174235		1-	B	e2
C 1096	CHIP TA.CAP.	10uF	10V		TEMSVA1A106M-8R	K78100028		1-	B	c4
C 1097	CHIP CAP.	0.001uF	50V	B	GRM39B102K50PT	K22174821		1-	A	E4
C 1098	CHIP CAP.	0.01uF	25V	B	GRM39B103K25PT	K22144803		1-	B	e2
C 1099	CHIP TA.CAP.	0.68uF	20V		TESVA1D684M1-8R	K78130009		1-	A	E5
C 1100	CHIP CAP.	0.001uF	50V	B	GRM39B102K50PT	K22174821		1-	A	C2
C 1101	CHIP CAP.	10pF	50V	CH	GRM39CH100D50PT	K22174211		1-	B	e2
C 1102	CHIP CAP.	0.01uF	25V	B	GRM39B103K25PT	K22144803		1-	A	D3
C 1103	CHIP CAP.	0.01uF	25V	B	GRM39B103K25PT	K22144803		1-	A	F5
C 1105	CHIP CAP.	10pF	50V	CH	GRM39CH100D50PT	K22174211		1-	B	d2
C 1106	CHIP CAP.	0.001uF	50V	B	GRM39B102K50PT	K22174821		1-	A	E4
C 1107	CHIP CAP.	15pF	50V	CH	GRM39CH150J50PT	K22174215		1-3	B	d2
C 1107	CHIP CAP.	22pF	50V	CH	GRM39CH220J50PT	K22174219	VERSION A	4-	B	d2
C 1107	CHIP CAP.	15pF	50V	CH	GRM39CH150J50PT	K22174215	VERSION C	4-	B	d2
C 1108	CHIP CAP.	6pF	50V	CH	GRM39CH060D50PT	K22174207		1-	B	c4
C 1109	CHIP CAP.	3pF	50V	CJ	GRM39CJ030C50PT	K22174204		1-	A	E3
C 1110	CHIP CAP.	0.001uF	50V	B	GRM39B102K50PT	K22174821		1-	A	E4
C 1111	CHIP CAP.	0.001uF	50V	B	GRM39B102K50PT	K22174821		1-	A	F3
C 1112	CHIP CAP.	0.001uF	50V	B	GRM39B102K50PT	K22174821		1-	B	e2
C 1113	CHIP CAP.	0.001uF	50V	B	GRM39B102K50PT	K22174821		1-	A	C3
C 1114	CHIP CAP.	18pF	50V	CH	GRM39CH180J50PT	K22174217		1-	A	E4
C 1115	CHIP TA.CAP.	1uF	16V		TESVA1C105M1-8R	K78120009		1-	A	C3
C 1116	CHIP CAP.	0.001uF	50V	B	GRM39B102K50PT	K22174821		1-	B	e2
C 1117	CHIP CAP.	0.001uF	50V	B	GRM39B102K50PT	K22174821		1-	B	b4
C 1118	CHIP CAP.	10pF	50V	CH	GRM39CH100D50PT	K22174211		1-	B	b4
C 1119	CHIP CAP.	0.001uF	50V	B	GRM39B102K50PT	K22174821		1-	B	e2

REF.	DESCRIPTION	VALUE	WV	TOL.	MFR'S DESIG	VXSTD P/N	VERS.	LOT.	SIDE	LAY ADR.
C 1120	CHIP CAP.	12pF	50V	CH	GRM39CH120J50PT	K22174213		1-	B	c4
C 1121	CHIP CAP.	47pF	50V	CH	GRM39CH470J50PT	K22174227		1-	B	c4
C 1122	CHIP CAP.	12pF	50V	CH	GRM39CH120J50PT	K22174213		1-3	B	d2
C 1122	CHIP CAP.	18pF	50V	CH	GRM39CH180J50PT	K22174217	VERSION A	4-	B	d2
C 1122	CHIP CAP.	12pF	50V	CH	GRM39CH120J50PT	K22174213	VERSION C	4-	B	d2
C 1123	CHIP CAP.	0.001uF	50V	B	GRM39B102K50PT	K22174821		1-	B	e2
C 1124	CHIP CAP.	33pF	50V	CH	GRM39CH330J50PT	K22174223		1-	B	c5
C 1125	CHIP CAP.	0.001uF	50V	B	GRM39B102K50PT	K22174821		1-	B	d3
C 1127	CHIP CAP.	12pF	50V	CH	GRM39CH120J50PT	K22174213		1-	B	b4
C 1128	CHIP CAP.	0.001uF	50V	B	GRM39B102K50PT	K22174821		1-	A	E4
C 1129	CHIP TA.CAP.	4.7uF	10V		TEMSVA1A475M-8R	K78100022		1-	B	c3
C 1129	CHIP TA.CAP.	4.7uF	16V		TEMSVA1C475M-8R	K78120031		4-	B	c3
C 1130	CHIP CAP.	0.001uF	50V	B	GRM39B102K50PT	K22174821		1-	B	e3
C 1131	CHIP CAP.	2pF	50V	CK	GRM39CK020C50PT	K22174203		1-11	B	d3
C 1131	CHIP CAP.	4pF	50V	CH	GRM39CH040C50PT	K22174205	VERSION A	12-	B	d3
C 1131	CHIP CAP.	2pF	50V	CK	GRM39CK020C50PT	K22174203	VERSION C	12-	B	d3
C 1132	CHIP CAP.	4pF	50V	CH	GRM39CH040C50PT	K22174205		1-	B	c3
C 1133	CHIP TA.CAP.	4.7uF	10V		TEMSVA1A475M-8R	K78100022		1-	B	b5
C 1133	CHIP TA.CAP.	4.7uF	16V		TEMSVA1C475M-8R	K78120031		4-	B	b5
C 1134	CHIP CAP.	0.001uF	50V	B	GRM39B102K50PT	K22174821		1-	B	d4
C 1135	CHIP CAP.	0.001uF	50V	B	GRM39B102K50PT	K22174821		1-	B	b5
C 1136	CHIP CAP.	0.001uF	50V	B	GRM39B102K50PT	K22174821		1-	B	d3
C 1137	CHIP CAP.	220pF	50V	CH	GRM39CH221J50PT	K22174243		1-	B	b5
C 1138	CHIP CAP.	18pF	50V	CH	GRM39CH180J50PT	K22174217		1-	B	d3
C 1139	CHIP CAP.	27pF	50V	CH	GRM39CH270J50PT	K22174221		1-	B	c4
C 1140	CHIP CAP.	100pF	50V	CH	GRM39CH101J50PT	K22174235		1-	B	b5
C 1141	CHIP CAP.	1pF	50V	CK	GRM39CK010C50PT	K22174202		1-3	B	c4
C 1141	CHIP CAP.	2pF	50V	CK	GRM39CK020C50PT	K22174203	VERSION A	4-	B	c4
C 1141	CHIP CAP.	1pF	50V	CK	GRM39CK010C50PT	K22174202	VERSION C	4-	B	c4
C 1142	CHIP CAP.	6pF	50V	CH	GRM39CH060D50PT	K22174207		1-	B	c4
C 1144	CHIP CAP.	100pF	50V	CH	GRM39CH101J50PT	K22174235		1-	B	b5
C 1145	CHIP TA.CAP.	10uF	10V		TEMSVA1A106M-8R	K78100028		1-	B	b5
C 1146	CHIP CAP.	33pF	50V	CH	GRM39CH330J50PT	K22174223		1-	B	b5
C 1147	CHIP CAP.	0.001uF	50V	B	GRM39B102K50PT	K22174821		1-	B	b5
C 1148	CHIP CAP.	0.001uF	50V	B	GRM39B102K50PT	K22174821		1-	B	b4
C 1149	CHIP CAP.	0.001uF	50V	B	GRM39B102K50PT	K22174821		1-	B	b4
C 1150	CHIP CAP.	0.001uF	50V	B	GRM39B102K50PT	K22174821		1-	A	F4
C 1151	CHIP CAP.	0.01uF	25V	B	GRM39B103K25PT	K22144803		1-	B	b4
C 1152	CHIP CAP.	0.1uF	16V	B	GRM39B104K16PT	K22124805		1-	B	b5
C 1153	CHIP CAP.	0.001uF	50V	B	GRM39B102K50PT	K22174821		1-	B	b4
C 1154	CHIP CAP.	0.1uF	16V	B	GRM39B104K16PT	K22124805		1-	B	b5
C 1155	CHIP CAP.	220pF	50V	CH	GRM39CH221J50PT	K22174243		1-	B	a4
C 1156	CHIP CAP.	15pF	50V	CH	GRM39CH150J50PT	K22174215		1-	B	b4
C 1157	CHIP CAP.	0.01uF	25V	B	GRM39B103K25PT	K22144803		1-	B	a4
C 1158	CHIP CAP.	0.01uF	25V	B	GRM39B103K25PT	K22144803		1-	B	b4
C 1159	CHIP CAP.	0.01uF	25V	B	GRM39B103K25PT	K22144803		1-	B	b4
C 1160	CHIP CAP.	0.001uF	50V	B	GRM39B102K50PT	K22174821		1-	B	b4
C 1161	CHIP CAP.	0.001uF	50V	B	GRM39B102K50PT	K22174821		1-	A	F5
C 1162	CHIP CAP.	0.001uF	50V	B	GRM39B102K50PT	K22174821		1-	A	G4
C 1163	CHIP CAP.	22pF	50V	CH	GRM39CH220J50PT	K22174219		1-	B	a4
C 1164	CHIP CAP.	0.01uF	25V	B	GRM39B103K25PT	K22144803		1-	B	a5
C 1165	CHIP CAP.	0.01uF	25V	B	GRM39B103K25PT	K22144803		1-	B	a4
C 1166	CHIP CAP.	0.01uF	25V	B	GRM39B103K25PT	K22144803		1-	B	a4
C 1167	CHIP CAP.	0.001uF	50V	B	GRM39B102K50PT	K22174821		1-	A	G4
C 1168	CHIP CAP.	120pF	50V	CH	GRM39CH121J50PT	K22174237		1-	A	G4
C 1169	CHIP CAP.	15pF	50V	CH	GRM39CH150J50PT	K22174215		1-	B	b4
C 1170	CHIP CAP.	0.1uF	16V	B	GRM39B104K16PT	K22124805		1-	A	G4
C 1171	CHIP CAP.	47pF	50V	CH	GRM39CH470J50PT	K22174227		1-	B	b4
C 1172	CHIP CAP.	12pF	50V	CH	GRM39CH120J50PT	K22174213		1-	B	b4
C 1173	CHIP CAP.	0.01uF	25V	B	GRM39B103K25PT	K22144803		1-	B	a4

MAIN Unit

REF.	DESCRIPTION	VALUE	WV	TOL.	MFR'S DESIG	VXSTD P/N	VERS.	LOT.	SIDE	LAY ADR.
C 1174	CHIP CAP.	82pF	50V	CH	GRM39CH820J50PT	K22174233		1-	A	G4
C 1175	CHIP CAP.	0.1uF	16V	B	GRM39B104K16PT	K22124805		1-	A	G4
C 1177	CHIP CAP.	0.0056uF	50V	B	GRM39B562M50PT	K22174818		1-	B	b5
C 1179	CHIP CAP.	0.01uF	25V	B	GRM39B103K25PT	K22144803		1-	B	a4
C 1182	CHIP TA.CAP.	33uF	10V		TEMSVB21A336M-8R	K78100047		1-	B	a4
C 1184	CHIP CAP.	27pF	50V	CH	GRM39CH270J50PT	K22174221		1-	B	b5
C 1185	CHIP CAP.	5pF	50V	CH	GRM39CH050C50PT	K22174206		1-	B	b5
C 1186	CHIP CAP.	0.01uF	25V	B	GRM39B103K25PT	K22144803		1-	A	F4
C 1189	CHIP CAP.	220pF	50V	CH	GRM39CH221J50PT	K22174243		1-	B	b5
C 1191	CHIP CAP.	0.001uF	50V	B	GRM39B102K50PT	K22174821		1-	A	G4
C 1192	CHIP CAP.	27pF	50V	CH	GRM39CH270J50PT	K22174221		1-	A	G4
C 1195	CHIP CAP.	0.01uF	25V	B	GRM39B103K25PT	K22144803		1-	B	a5
C 1198	CHIP CAP.	0.01uF	25V	B	GRM39B103K25PT	K22144803		1-	B	a4
C 1199	CHIP CAP.	0.001uF	50V	B	GRM39B102K50PT	K22174821		1-	A	G4
C 1200	CHIP CAP.	0.001uF	50V	B	GRM39B102K50PT	K22174821		1-	A	D3
C 1201	CHIP CAP.	0.001uF	50V	B	GRM39B102K50PT	K22174821		1-	A	G4
C 1202	CHIP TA.CAP.	10uF	20V		TEMSVB21D106M-8R	K78130028		1-	A	D2
C 1203	CHIP CAP.	0.001uF	50V	B	GRM39B102K50PT	K22174821		1-	B	d3
C 1204	CHIP CAP.	0.001uF	50V	B	GRM39B102K50PT	K22174821		1-	B	b3
C 1205	CHIP CAP.	0.001uF	50V	B	GRM39B102K50PT	K22174821		1-	B	c3
C 1206	CHIP CAP.	3pF	50V	CJ	GRM39CJ030C50PT	K22174204		1-	A	E5
C 1207	CHIP CAP.	10pF	50V	CH	GRM39CH100D50PT	K22174211		1-	A	E4
C 1210	FILM CAP.	5pF	500V		UC232H0050D-T	K33279010	VERSION C	4-	A	F2
C 1210	FILM CAP.	2pF	500V		UC232H0020D-T	K33279043	VERSION C	10-	A	F2
C 1211	CHIP CAP.	10pF	500V	CH	GRM42-6CH100D500PT	K22271213		2-3		
C 1212	CHIP CAP.	150pF	300V	CH	GRH111CH151J300	K22253201		2		
C 1212	CHIP CAP.	82pF	500V	CH	GRM42-6CH820J500PT	K22271235		3		
C 1212	CHIP CAP.	150pF	300V	CH	GRH111CH151J300	K22253201	VERSION C	4-		
C 1213	CHIP CAP.	7pF	500V	CH	GRM42-6CH070D500PT	K22271210		2-3		
C 1213	CHIP CAP.	7pF	500V	CH	GRM42-6CH070D500PT	K22271210	VERSION C	4-		
C 1213	CHIP CAP.	5pF	500V	CH	GRM42-6CH050C500PT	K22271208	VERSION C	10-		
C 1214	CHIP CAP.	82pF	500V	CH	GRM42-6CH820J500PT	K22271235		3		
C 2001	CHIP TA.CAP.	10uF	10V		TEMSVA1A106M-8R	K78100028		1-	A	A1
C 2002	CHIP TA.CAP.	10uF	10V		TEMSVA1A106M-8R	K78100028		1-	A	A1
C 2003	CHIP CAP.	100pF	50V	CH	GRM39CH101J50PT	K22174235		1-	B	g4
C 2004	CHIP CAP.	100pF	50V	CH	GRM39CH101J50PT	K22174235		1-	A	B1
C 2005	CHIP CAP.	100pF	50V	CH	GRM39CH101J50PT	K22174235		1-	A	A1
C 2006	CHIP CAP.	100pF	50V	CH	GRM39CH101J50PT	K22174235		1-	A	A1
C 2007	CHIP CAP.	100pF	50V	CH	GRM39CH101J50PT	K22174235		1-	A	A1
C 2008	CHIP CAP.	100pF	50V	CH	GRM39CH101J50PT	K22174235		1-	A	B1
C 2009	CHIP CAP.	100pF	50V	CH	GRM39CH101J50PT	K22174235		1-	B	g1
C 2010	CHIP CAP.	100pF	50V	CH	GRM39CH101J50PT	K22174235		1-	B	f5
C 2011	CHIP CAP.	100pF	50V	CH	GRM39CH101J50PT	K22174235		1-	B	f5
C 2012	CHIP TA.CAP.	4.7uF	10V		TEMSVA1A475M-8R	K78100022		1-	B	f5
C 2012	CHIP TA.CAP.	4.7uF	16V		TEMSVA1C475M-8R	K78120031		4-	B	f5
C 2013	CHIP CAP.	220pF	50V	CH	GRM39CH221J50PT	K22174243		1-	B	f5
C 2014	CHIP CAP.	100pF	50V	CH	GRM39CH101J50PT	K22174235		1-	B	f5
C 2015	CHIP CAP.	100pF	50V	CH	GRM39CH101J50PT	K22174235		1-	B	f5
C 2016	CHIP TA.CAP.	4.7uF	10V		TEMSVA1A475M-8R	K78100022		1-	B	f5
C 2016	CHIP TA.CAP.	4.7uF	16V		TEMSVA1C475M-8R	K78120031		4-	B	f5
C 2018	CHIP CAP.	100pF	50V	CH	GRM39CH101J50PT	K22174235		1-	B	e5
C 2019	CHIP TA.CAP.	4.7uF	10V		TEMSVA1A475M-8R	K78100022		1-	B	e5
C 2019	CHIP TA.CAP.	4.7uF	16V		TEMSVA1C475M-8R	K78120031		4-	B	e5
C 2020	AL.ELECTRO.CAP.	100uF	16V		ECEV1CA101WP	K48120012		1-	A	A2
C 2021	CHIP CAP.	0.1uF	16V	B	GRM39B104K16PT	K22124805		1-	A	A2
C 2022	CHIP CAP.	0.001uF	50V	B	GRM39B102K50PT	K22174821		1-	A	B5
C 2023	CHIP CAP.	0.001uF	50V	B	GRM39B102K50PT	K22174821		1-	B	f5
C 2024	CHIP CAP.	0.1uF	16V	B	GRM39B104K16PT	K22124805		1-	B	g3
C 2024	CHIP CAP.	0.22uF	10V	B	GRM39B224K10PT	K22104801		4-	B	g3
C 2027	CHIP CAP.	220pF	50V	CH	GRM39CH221J50PT	K22174243		1-	B	e5

REF.	DESCRIPTION	VALUE	WV	TOL.	MFR'S DESIG	VXSTD P/N	VERS.	LOT.	SIDE	LAY ADR.
C 2028	CHIP CAP.	0.1uF	16V	B	GRM39B104K16PT	K22124805		1-	A	C5
C 2029	CHIP CAP.	0.1uF	16V	B	GRM39B104K16PT	K22124805		1-	B	f5
C 2030	CHIP CAP.	47pF	50V	CH	GRM39CH470J50PT	K22174227		1-	B	f5
C 2031	CHIP TA.CAP.	10uF	10V		TEMSVA1A106M-8R	K78100028		1-	B	g3
C 2032	CHIP TA.CAP.	10uF	10V		TEMSVA1A106M-8R	K78100028		1-	A	A3
C 2034	CHIP CAP.	1uF	10V	F	GRM39F105Z10PT	K22105001		1-	A	A3
C 2036	CHIP CAP.	0.1uF	16V	B	GRM39B104K16PT	K22124805		1-	B	e5
C 2037	CHIP CAP.	0.1uF	16V	B	GRM39B104K16PT	K22124805		1-	A	C5
C 2038	CHIP CAP.	0.1uF	16V	B	GRM39B104K16PT	K22124805		1-	B	f3
C 2039	CHIP CAP.	0.047uF	16V	B	GRM39B473K16PT	K22124804		1-	B	f3
C 2040	CHIP TA.CAP.	1uF	16V		TESVA1C105M1-8R	K78120009		1-	B	d4
C 2041	CHIP TA.CAP.	4.7uF	10V		TEMSVA1A475M-8R	K78100022		1-	A	D4
C 2041	CHIP TA.CAP.	4.7uF	16V		TEMSVA1C475M-8R	K78120031		4-	A	D4
C 2042	CHIP TA.CAP.	1uF	16V		TESVA1C105M1-8R	K78120009		1-	A	D4
C 2043	CHIP CAP.	0.0022uF	50V	B	GRM39B222M50PT	K22174813		1-	A	C5
C 2043	CHIP CAP.	0.0022uF	50V	B	GRM39B222K50PT	K22174822		4-	A	C5
C 2044	CHIP CAP.	270pF	50V	B	GRM39B271M50PT	K22174802		1-	B	d5
C 2045	CHIP CAP.	0.01uF	25V	B	GRM39B103K25PT	K22144803		1-	B	d4
C 2046	CHIP CAP.	0.01uF	25V	B	GRM39B103K25PT	K22144803		1-	B	d4
C 2047	CHIP CAP.	0.01uF	25V	B	GRM39B103K25PT	K22144803		1-	A	C5
C 2048	CHIP CAP.	0.022uF	25V	B	GRM39B223K25PT	K22144807		1-	A	C4
C 2049	CHIP CAP.	0.1uF	16V	B	GRM39B104K16PT	K22124805		1-	A	D5
C 2050	CHIP CAP.	0.1uF	16V	B	GRM39B104K16PT	K22124805		1-	B	e4
C 2051	CHIP CAP.	0.1uF	16V	B	GRM39B104K16PT	K22124805		1-	B	e4
C 2052	CHIP CAP.	0.1uF	16V	B	GRM39B104K16PT	K22124805		1-	B	e4
C 2053	CHIP TA.CAP.	1uF	16V		TESVA1C105M1-8R	K78120009		1-	A	C4
C 2055	CHIP CAP.	0.1uF	16V	B	GRM39B104K16PT	K22124805		1-	B	e4
C 2056	CHIP CAP.	0.01uF	25V	B	GRM39B103K25PT	K22144803		1-	A	C3
C 2057	CHIP TA.CAP.	4.7uF	10V		TEMSVA1A475M-8R	K78100022		1-	A	C3
C 2057	CHIP TA.CAP.	4.7uF	16V		TEMSVA1C475M-8R	K78120031		4-	A	C3
C 2058	CHIP CAP.	220pF	50V	CH	GRM39CH221J50PT	K22174243		1-	A	C3
C 2059	CHIP CAP.	220pF	50V	CH	GRM39CH221J50PT	K22174243		1-	A	C3
C 2060	CHIP CAP.	0.01uF	25V	B	GRM39B103K25PT	K22144803		1-	A	B4
C 2061	CHIP CAP.	0.01uF	25V	B	GRM39B103K25PT	K22144803		1-	A	B4
C 2062	CHIP TA.CAP.	4.7uF	10V		TEMSVA1A475M-8R	K78100022		1-	A	C5
C 2062	CHIP TA.CAP.	4.7uF	16V		TEMSVA1C475M-8R	K78120031		4-	A	C5
C 2063	CHIP CAP.	0.1uF	16V	B	GRM39B104K16PT	K22124805		1-	A	C5
C 2064	CHIP CAP.	0.0022uF	50V	B	GRM39B222K50PT	K22174822		1-	A	C5
C 2065	CHIP TA.CAP.	4.7uF	10V		TEMSVA1A475M-8R	K78100022		1-	A	C5
C 2065	CHIP TA.CAP.	4.7uF	16V		TEMSVA1C475M-8R	K78120031		4-	A	C5
C 2066	CHIP CAP.	0.022uF	25V	B	GRM39B223K25PT	K22144807		1-	B	e4
C 2067	CHIP CAP.	0.001uF	50V	B	GRM39B102K50PT	K22174821		1-	B	e5
C 2068	CHIP CAP.	270pF	50V	B	GRM39B271M50PT	K22174802		1-	B	d5
C 2069	CHIP TA.CAP.	10uF	10V		TEMSVA1A106M-8R	K78100028		1-	A	D5
C 2070	CHIP CAP.	470pF	50V	CH	GRM39CH471J50PT	K22174249		1-	B	d4
C 2071	CHIP CAP.	330pF	50V	B	GRM39B331K50PT	K22174820		1-	B	d4
C 2072	CHIP CAP.	0.1uF	16V	B	GRM39B104K16PT	K22124805		1-	B	d4
C 2073	CHIP CAP.	0.01uF	25V	B	GRM39B103K25PT	K22144803		1-	B	d5
C 2074	CHIP CAP.	470pF	50V	CH	GRM39CH471J50PT	K22174249		1-	B	d4
C 2075	CHIP TA.CAP.	1uF	16V		TESVA1C105M1-8R	K78120009		1-	A	D4
C 2076	CHIP CAP.	470pF	50V	CH	GRM39CH471J50PT	K22174249		1-	B	d4
C 2078	CHIP CAP.	0.1uF	16V	B	GRM39B104K16PT	K22124805		1-	A	C4
C 2079	CHIP CAP.	22pF	50V	CH	GRM39CH220J50PT	K22174219		1-	B	d4
C 2080	CHIP CAP.	0.1uF	16V	B	GRM39B104K16PT	K22124805		1-	A	C5
C 2081	CHIP CAP.	0.001uF	50V	B	GRM39B102K50PT	K22174821		1-	A	C5
C 2082	CHIP TA.CAP.	4.7uF	10V		TEMSVA1A475M-8R	K78100022		1-	A	D5
C 2082	CHIP TA.CAP.	4.7uF	16V		TEMSVA1C475M-8R	K78120031		4-	A	D5
C 2083	CHIP CAP.	22pF	50V	CH	GRM39CH220J50PT	K22174219		1-	B	e5
C 2084	CHIP CAP.	0.01uF	25V	B	GRM39B103K25PT	K22144803		1-	B	d5
C 2085	CHIP CAP.	0.01uF	25V	B	GRM39B103K25PT	K22144803		1-	B	d5

MAIN Unit

REF.	DESCRIPTION	VALUE	WV	TOL.	MFR'S DESIG	VXSTD P/N	VERS.	LOT.	SIDE	LAY ADR.
C 2086	CHIP CAP.	330pF	50V	B	GRM39B331K50PT	K22174820		1-	B	d5
C 2087	CHIP CAP.	0.01uF	25V	B	GRM39B103K25PT	K22144803		1-	B	d5
C 2088	CHIP CAP.	0.01uF	25V	B	GRM39B103K25PT	K22144803		1-	B	d5
C 2089	CHIP CAP.	470pF	50V	CH	GRM39CH471J50PT	K22174249		1-	B	d4
C 2090	CHIP CAP.	0.0047uF	50V	B	GRM39B472M50PT	K22174817		1-	B	d4
C 2090	CHIP CAP.	0.0047uF	50V	B	GRM39B472K50PT	K22174833		4-	B	d4
C 2091	CHIP CAP.	9pF	50V	CH	GRM39CH090D50PT	K22174210		1-	B	g4
C 2092	CHIP CAP.	4pF	50V	CH	GRM39CH040C50PT	K22174205		1-	A	A4
C 2093	CHIP CAP.	18pF	50V	CH	GRM39CH180J50PT	K22174217		1-	A	A4
C 2094	CHIP CAP.	820pF	50V	B	GRM39B821M50PT	K22174808		1-	B	d4
C 2095	CHIP CAP.	0.0056uF	50V	B	GRM39B562M50PT	K22174818		1-	B	d4
C 2096	CHIP TA.CAP.	1uF	16V		TESVA1C105M1-8R	K78120009		1-	B	e4
C 2097	CHIP CAP.	0.1uF	16V	B	GRM39B104K16PT	K22124805		1-	A	D4
C 2098	CHIP TA.CAP.	4.7uF	10V		TEMSVA1A475M-8R	K78100022		1-	A	D4
C 2098	CHIP TA.CAP.	4.7uF	16V		TEMSVA1C475M-8R	K78120031		4-	A	D4
C 2099	CHIP TA.CAP.	4.7uF	10V		TEMSVA1A475M-8R	K78100022		1-	A	D4
C 2099	CHIP TA.CAP.	4.7uF	16V		TEMSVA1C475M-8R	K78120031		4-	A	D4
C 2100	CHIP CAP.	7pF	50V	CH	GRM39CH070D50PT	K22174208		1-	A	D4
C 2101	CHIP CAP.	0.1uF	16V	B	GRM39B104K16PT	K22124805		1-	A	D4
C 2102	CHIP CAP.	0.1uF	16V	B	GRM39B104K16PT	K22124805		1-	B	d4
C 2103	CHIP TA.CAP.	1uF	16V		TESVA1C105M1-8R	K78120009		1-	B	e4
C 2104	CHIP TA.CAP.	1uF	16V		TESVA1C105M1-8R	K78120009		1-	B	e4
C 2105	CHIP CAP.	820pF	50V	B	GRM39B821M50PT	K22174808		1-	B	e5
C 2106	CHIP CAP.	0.0012uF	50V	B	GRM39B122K50PT	K22174826		1-	B	e5
C 2107	CHIP CAP.	220pF	50V	CH	GRM39CH221J50PT	K22174243		1-	B	e5
C 2108	CHIP CAP.	0.01uF	25V	B	GRM39B103K25PT	K22144803		1-	B	d5
C 2109	CHIP CAP.	0.001uF	50V	B	GRM39B102K50PT	K22174821		1-	B	d4
C 2110	CHIP CAP.	0.0022uF	50V	B	GRM39B222K50PT	K22174822		1-	B	d5
C 2111	CHIP CAP.	100pF	50V	CH	GRM39CH101J50PT	K22174235		1-	B	d5
C 2112	CHIP CAP.	220pF	50V	CH	GRM39CH221J50PT	K22174243		1-	B	f1
C 2113	CHIP CAP.	0.01uF	25V	B	GRM39B103K25PT	K22144803		1-	B	f2
C 2114	CHIP CAP.	0.01uF	25V	B	GRM39B103K25PT	K22144803		1-	A	A5
C 2115	CHIP CAP.	0.01uF	25V	B	GRM39B103K25PT	K22144803		1-	B	d5
C 2116	CHIP CAP.	0.001uF	50V	B	GRM39B102K50PT	K22174821		1-	B	g4
C 2117	CHIP CAP.	0.1uF	16V	B	GRM39B104K16PT	K22124805		1-	B	d5
C 2119	AL.ELECTRO.CAP.	470uF	16V		RE3-16V471M 470UF	K40129066		1-	A	B2
C 2120	CHIP CAP.	0.001uF	50V	B	GRM39B102K50PT	K22174821		1-	B	f2
C 2122	CHIP CAP.	0.1uF	16V	B	GRM39B104K16PT	K22124805		1-	B	f4
C 2123	CHIP CAP.	0.01uF	25V	B	GRM39B103K25PT	K22144803		1-	B	g4
C 2124	CHIP CAP.	0.01uF	25V	B	GRM39B103K25PT	K22144803		1-	B	g4
C 2126	CHIP CAP.	0.1uF	16V	B	GRM39B104K16PT	K22124805		1-	A	D5
C 2128	CHIP CAP.	0.1uF	16V	B	GRM39B104K16PT	K22124805		1-	B	g4
C 2129	CHIP CAP.	47pF	50V	CH	GRM39CH470J50PT	K22174227		1-	B	d5
C 2130	CHIP CAP.	0.001uF	50V	B	GRM39B102K50PT	K22174821		1-	B	f2
C 2131	CHIP CAP.	0.01uF	25V	B	GRM39B103K25PT	K22144803		1-	B	f3
C 2132	CHIP CAP.	0.22uF	10V	B	GRM39B224K10PT	K22104801		1-	B	f2
C 2133	CHIP TA.CAP.	4.7uF	10V		TEMSVA1A475M-8R	K78100022		1-	B	g5
C 2133	CHIP TA.CAP.	4.7uF	16V		TEMSVA1C475M-8R	K78120031		4-	B	g5
C 2134	CHIP TA.CAP.	10uF	10V		TEMSVA1A106M-8R	K78100028		1-	B	f2
C 2135	CHIP CAP.	0.01uF	25V	B	GRM39B103K25PT	K22144803		1-	B	f2
C 2137	CHIP TA.CAP.	4.7uF	10V		TEMSVA1A475M-8R	K78100022		1-	B	f5
C 2137	CHIP TA.CAP.	4.7uF	16V		TEMSVA1C475M-8R	K78120031		4-	B	f5
C 2138	CHIP TA.CAP.	4.7uF	10V		TEMSVA1A475M-8R	K78100022		1-	B	f3
C 2138	CHIP TA.CAP.	4.7uF	16V		TEMSVA1C475M-8R	K78120031		4-	B	f3
C 2139	CHIP CAP.	0.1uF	16V	B	GRM39B104K16PT	K22124805		1-	B	f4
C 2140	CHIP CAP.	0.1uF	16V	B	GRM39B104K16PT	K22124805		1-	B	g4
C 2141	CHIP TA.CAP.	4.7uF	10V		TEMSVA1A475M-8R	K78100022		1-	B	e4
C 2141	CHIP TA.CAP.	4.7uF	16V		TEMSVA1C475M-8R	K78120031		4-	B	e4
C 2142	CHIP CAP.	100pF	50V	CH	GRM39CH101J50PT	K22174235		1-	A	B1
C 2143	CHIP CAP.	100pF	50V	CH	GRM39CH101J50PT	K22174235		1-	A	B1

REF.	DESCRIPTION	VALUE	WV	TOL.	MFR'S DESIG	VXSTD P/N	VERS.	LOT.	SIDE	LAY ADR.
C 2144	CHIP TA.CAP.	4.7uF	10V		TEMSVA1A475M-8R	K78100022		1-	A	C5
C 2144	CHIP TA.CAP.	4.7uF	16V		TEMSVA1C475M-8R	K78120031		4-	A	C5
C 2145	CHIP TA.CAP.	4.7uF	10V		TEMSVA1A475M-8R	K78100022		1-	A	C5
C 2145	CHIP TA.CAP.	4.7uF	16V		TEMSVA1C475M-8R	K78120031		4-	A	C5
C 2146	CHIP CAP.	470pF	50V	B	GRM39B471M50PT	K22174805		1-	B	f5
C 2146	CHIP CAP.	470pF	50V	CH	GRM39CH471J50PT	K22174249		4-	B	f5
C 2147	CHIP CAP.	470pF	50V	B	GRM39B471M50PT	K22174805		1-	B	f5
C 2147	CHIP CAP.	470pF	50V	CH	GRM39CH471J50PT	K22174249		4-	B	f5
C 2148	CHIP CAP.	470pF	50V	B	GRM39B471M50PT	K22174805		1-	B	f5
C 2148	CHIP CAP.	470pF	50V	CH	GRM39CH471J50PT	K22174249		4-	B	f5
C 2149	CHIP CAP.	470pF	50V	B	GRM39B471M50PT	K22174805		1-	B	g5
C 2149	CHIP CAP.	470pF	50V	CH	GRM39CH471J50PT	K22174249		4-	B	g5
C 2150	CHIP CAP.	0.1uF	16V	B	GRM39B104K16PT	K22124805		1-	A	C5
C 2154	CHIP CAP.	33pF	50V	CH	GRM39CH330J50PT	K22174223		1-	B	d3
C 2156	CHIP CAP.	100pF	50V	CH	GRM39CH101J50PT	K22174235		1-	A	B1
C 2157	CHIP CAP.	100pF	50V	CH	GRM39CH101J50PT	K22174235		1-	A	A1
C 2158	CHIP CAP.	100pF	50V	CH	GRM39CH101J50PT	K22174235		1-	A	A1
C 2159	CHIP CAP.	100pF	50V	CH	GRM39CH101J50PT	K22174235		1-	A	A1
C 2160	CHIP CAP.	100pF	50V	CH	GRM39CH101J50PT	K22174235		1-	A	A1
C 2161	CHIP CAP.	100pF	50V	CH	GRM39CH101J50PT	K22174235		1-	A	A1
C 2162	CHIP CAP.	100pF	50V	CH	GRM39CH101J50PT	K22174235		1-	A	A1
C 2163	CHIP CAP.	100pF	50V	CH	GRM39CH101J50PT	K22174235		1-	A	A1
C 2164	CHIP CAP.	100pF	50V	CH	GRM39CH101J50PT	K22174235		1-	A	A1
C 2165	CHIP CAP.	100pF	50V	CH	GRM39CH101J50PT	K22174235		1-	A	B1
C 2166	CHIP CAP.	100pF	50V	CH	GRM39CH101J50PT	K22174235		1-	A	B1
C 2167	CHIP CAP.	100pF	50V	CH	GRM39CH101J50PT	K22174235		1-	A	B1
C 2168	CHIP CAP.	100pF	50V	CH	GRM39CH101J50PT	K22174235		1-	A	B1
C 2169	CHIP CAP.	100pF	50V	CH	GRM39CH101J50PT	K22174235		1-	A	B1
C 2170	CHIP CAP.	100pF	50V	CH	GRM39CH101J50PT	K22174235		1-	A	B1
C 2171	CHIP CAP.	0.01uF	25V	B	GRM39B103K25PT	K22144803		1-	B	g4
C 2172	CHIP CAP.	0.01uF	25V	B	GRM39B103K25PT	K22144803		1-	B	f3
C 2173	CHIP CAP.	0.01uF	25V	B	GRM39B103K25PT	K22144803		1-	B	f3
C 2174	CHIP CAP.	0.01uF	25V	B	GRM39B103K25PT	K22144803		1-	B	f3
C 2175	CHIP CAP.	0.01uF	25V	B	GRM39B103K25PT	K22144803		1-	B	f3
C 2197	CHIP CAP.	470pF	50V	CH	GRM39CH471J50PT	K22174249		4-	B	a2
C 2199	CHIP CAP.	0.1uF	16V	B	GRM39B104K16PT	K22124805		1-	B	g3
C 2200	CHIP CAP.	0.01uF	25V	B	GRM39B103K25PT	K22144803		1-	A	B3
C 2201	CHIP CAP.	0.047uF	16V	B	GRM39B473K16PT	K22124804		1-	B	f2
C 2203	CHIP CAP.	0.1uF	16V	B	GRM39B104K16PT	K22124805		1-	B	g3
C 2203	CHIP CAP.	0.22uF	10V	B	GRM39B224K10PT	K22104801		4-	B	g3
C 2204	CHIP CAP.	0.1uF	16V	B	GRM39B104K16PT	K22124805		1-3	A	B2
C 2205	CHIP CAP.	0.1uF	16V	B	GRM39B104K16PT	K22124805		1-3	B	f3
C 2206	CHIP CAP.	100pF	50V	CH	GRM39CH101J50PT	K22174235		4-	A	A5
C 2207	CHIP CAP.	0.001uF	50V	B	GRM39B102K50PT	K22174821		4-	B	g5
C 2208	AL.ELECTRO.CAP.	10uF	16V		RV2-16V100MB55-R	K48120014		4-	A	B2
C 2209	CHIP CAP.	0.1uF	16V	B	GRM39B104K16PT	K22124805		1-		
CD1001	CERAMIC DISC				CDBC450CX24-TC	H7901340		1-	B	a4
CF1001	CERAMIC FILTER				CFWM450G	H3900435		1-	A	G5
CF1002	CERAMIC FILTER				CFWM450E	H3900466		1-	A	G4
CO2001	CERAMIC OSC	1MHz			CSBF1000J221T-TC01	H7900950		1-	A	B3
D 1001	DIODE				RLS135 TE-11	G2070128		1-	B	a3
D 1002	DIODE				BAS316	G2070716		1-	B	a3
D 1003	SURGE ABSORBER				P6KA18	Q9000721		1-	A	B1
D 1005	DIODE				BAS316	G2070716		1-	A	D3
D 1006	DIODE				UM9957F/TR	G2070562		1-	B	a2
D 1007	DIODE				UM9957F/TR	G2070562		1-	B	a2
D 1008	DIODE				UM9957F/TR	G2070562		1-	B	a2
D 1009	DIODE				1SV229 TPH3	G2070256		1-	A	F3
D 1010	DIODE				1SV229 TPH3	G2070256		1-	A	F3
D 1011	DIODE				HSM88AS TR	G2070170		1-	A	F2

MAIN Unit

REF.	DESCRIPTION	VALUE	WV	TOL.	MFR'S DESIG	VXSTD P/N	VERS.	LOT.	SIDE.	LAY ADR.
D 1012	DIODE				1SV229 TPH3	G2070256		1-	A	F3
D 1013	DIODE				1SV229 TPH3	G2070256		1-	A	F3
D 1014	DIODE				HSM88AS TR	G2070170		1-	A	E2
D 1015	DIODE				HVU306A5TRF	G2070132		1-	A	E5
D 1016	DIODE				HVU306A5TRF	G2070132		1-	A	E5
D 1017	DIODE				HVU356TRF	G2070306		1-	A	E5
D 1018	DIODE				HVU356TRF	G2070306		1-	A	E5
D 1019	DIODE				1SV276(TPH3)	G2070420		1-	A	E5
D 1020	DIODE				1SV229 TPH3	G2070256		1-	A	E3
D 1021	DIODE				1SV229 TPH3	G2070256		1-	A	E3
D 1022	DIODE				1SV229 TPH3	G2070256		1-	A	E3
D 1023	DIODE				1SV229 TPH3	G2070256		1-	A	E3
D 1024	DIODE				1SS321 TE85R	G2070076		1-	B	d3
D 1026	DIODE				MC2848-T11-1	G2070694		1-	B	a5
D 1027	DIODE				HZM5.6NB2 TR	G2070722		1-	A	G5
D 1028	DIODE				MC2848-T11-1	G2070694		1-	B	a5
D 1029	DIODE				HVU359TRF	G2070452		1-	B	b5
D 1030	DIODE				1SV230 TPH3	G2070126		1-	B	b5
D 1031	SURGE ABSORBER				P6KA18	Q9000721		1-		
D 1033	DIODE				MC2850-T11-1	G2070704		1-	B	a5
D 1034	DIODE				BAS316	G2070716		1-	A	D3
D 1035	DIODE				HVU356TRF	G2070306		1-	A	E5
D 1036	DIODE				HVU356TRF	G2070306		1-	A	E5
D 2001	DIODE				MC2846-T11-1	G2070702		1-	B	g4
D 2002	DIODE				MC2850-T11-1	G2070704		1-	B	d4
D 2003	DIODE				MC2850-T11-1	G2070704		1-	A	C4
D 2004	DIODE				MC2850-T11-1	G2070704		1-	A	D4
D 2005	DIODE				BAS316	G2070716		1-	A	C4
D 2006	DIODE				MC2850-T11-1	G2070704		1-	B	f5
D 2007	DIODE				MC2846-T11-1	G2070702		1-	B	f2
D 2010	DIODE				MC2850-T11-1	G2070704		1-	B	g3
D 2011	DIODE				BAS316	G2070716		1-	A	A2
D 2012	DIODE				BAS316	G2070716		1-	B	g1
D 2013	DIODE				BAS316	G2070716		1-	B	g1
D 2014	DIODE				BAS316	G2070716		1-	A	A4
D 2015	DIODE				BAS316	G2070716		1-	A	A5
F 2001	CHIP FUSE	0.25A			KAB-2402-251NA31	Q0000085		1-	A	A1
J 2001	CONNECTOR				JBV-25S-1A3F	P1090815		1-	B	f1
J 2004	CONNECTOR				BM03B-SRSS-TBT	P0091301		1-	A	A2
J 2005	CONNECTOR				AXN426C530P	P0091296		1-	A	B4
L 1001	COIL				E2 0.28-1.0-6T-R	L0022366		1-	B	a3
L 1002	COIL	0.033uH			AS1005-33NK	L0022546		1-	A	G1
L 1003	COIL	0.033uH			AS1005-33NK	L0022546		1-	A	G2
L 1004	COIL				E2 0.25-1.85-8.5T-L	L0022576		1-	A	G3
L 1005	COIL				E2 0.25-1.85-8.5T-L	L0022576		1-	A	G3
L 1006	COIL	0.033uH			AS1005-33NK	L0022546		1-	A	G2
L 1007	COIL	0.033uH			AS1005-33NK	L0022546		1-	A	G2
L 1008	COIL				E2 0.25-1.9-12T-L	L0022592		1-	A	G3
L 1009	COIL				E2 0.35-1.6-4.5T-L	L0022577		1-	A	G3
L 1012	COIL	0.033uH			AS1005-33NK	L0022546		1-	A	G2
L 1013	COIL	0.11uH			AS0810-B0NK	L0022542		1-	A	F2
L 1014	M.RFC	10uH			LK1608 100K-T	L1690689		1-	A	E5
L 1015	M.RFC	33uH			LK1608 330M-T	L1690690		1-	A	E5
L 1018	COIL				E2 0.35-1.6-4.5T-L	L0022577		1-	A	F3
L 1019	COIL				E2 0.25-1.85-8.5T-L	L0022576		1-3	A	F3
L 1019	COIL				E2 0.25-1.9-8.5T-L	L0022611	VERSION A	4-	A	F3
L 1019	COIL				E2 0.25-1.85-8.5T-L	L0022576	VERSION C	4-	A	F3
L 1021	COIL				E2 0.3-1.7-7T-R	L0022372		1-3	A	E5
L 1021	COIL				E2 0.3-1.7-8T-L	L0022376	VERSION A	4-	A	E5
L 1021	COIL				E2 0.3-1.7-7T-R	L0022372	VERSION C	4-	A	E5

REF.	DESCRIPTION	VALUE	WV	TOL.	MFR'S DESIG	VXSTD P/N	VERS.	LOT.	SIDE	LAY ADR.
L 1022	COIL				E2 0.35-1.6-7T-L	L0022390		1-3	A	E5
L 1022	COIL				E2 0.3-1.7-7T-R	L0022372	VERSION A	4-	A	E5
L 1022	COIL				E2 0.35-1.6-7T-L	L0022390	VERSION C	4-	A	E5
L 1023	M.RFC	1uH			LK1608 1R0K-T	L1690687		1-	A	F3
L 1024	COIL				E2 0.25-1.9-12T-L	L0022592		1-	A	F3
L 1025	COIL				E2 0.35-1.6-4.5T-L	L0022577		1-	A	F3
L 1028	CHIP COIL	0.064uH			LQN1A64NJ04	L1690258		1-	B	d2
L 1030	M.RFC	0.047uH			HK1608 47NJ-T	L1690524		1-	A	E4
L 1031	CHIP COIL	0.084uH			LQN1A84NJ04	L1690259		1-	B	d2
L 1032	M.RFC	0.082uH			HK1608 82NJ-T	L1690527		1-	B	b4
L 1033	M.RFC	0.082uH			HK1608 82NJ-T	L1690527		1-	B	c5
L 1034	M.RFC	0.22uH			LK1608 R22K-T	L1690410		1-	B	e2
L 1037	M.RFC	0.082uH			HK1608 82NJ-T	L1690527		1-	B	b5
L 1038	COIL				E2 0.25-1.9-12T-L	L0022592		1-	A	E3
L 1039	COIL				E2 0.35-1.6-4.5T-L	L0022577		1-	A	E3
L 1040	M.RFC	0.082uH			HK1608 82NJ-T	L1690527		1-	B	e2
L 1041	M.RFC	0.33uH			LK1608 R33K-T	L1690412		1-	B	c4
L 1042	M.RFC	0.082uH			HK1608 82NJ-T	L1690527		1-	B	c3
L 1043	M.RFC	0.12uH			LK1608 R12K-T	L1690408		1-	B	d3
L 1044	M.RFC	0.22uH			LK1608 R22K-T	L1690410		1-	B	c4
L 1045	M.RFC	0.068uH			HK1608 68NJ-T	L1690526		1-	B	d3
L 1046	M.RFC	0.082uH			HK1608 82NJ-T	L1690527		1-	B	c4
L 1047	CHIP COIL	0.82uH			C2520C-R82J	L1690555		1-	B	b4
L 1048	M.RFC	0.1uH			HK1608 R10J-T	L1690528		1-	A	G4
L 1049	M.RFC	0.33uH			LK1608 R33K-T	L1690412		1-	A	G4
L 1050	M.RFC	33uH			LK1608 330M-T	L1690690		1-	A	E4
L 1051	M.RFC	33uH			LK1608 330M-T	L1690690		1-	A	E4
L 1052	M.RFC	33uH			LK1608 330M-T	L1690690		1-	A	E5
L 2001	M.RFC	2.2uH			LK1608 2R2K-T	L1690634		1-	A	A4
Q 1001	TRANSISTOR				2SC4154-T11-1E	G3341548E		1-	A	D2
Q 1002	TRANSISTOR				2SB1143S	G3211430S		1-	B	d2
Q 1003	TRANSISTOR				2SB1201S-TL	G3070195		1-	B	e3
Q 1004	TRANSISTOR				RT1N241M-T11-1	G3070249		1-	A	D3
Q 1005	TRANSISTOR				DTB123EK T146	G3070022		1-	B	e3
Q 1006	TRANSISTOR				2SB1132 T100 R	G3211327R		1-	B	e3
Q 1007	IC				NJM2902V-TE1	G1091679		1-	B	d3
Q 1008	TRANSISTOR				2SC4154-T11-1E	G3341548E		1-	B	d3
Q 1009	TRANSISTOR				IMH6A T108	G3070066		1-	B	e3
Q 1011	TRANSISTOR				RT1N241M-T11-1	G3070249		1-	B	d5
Q 1012	FET				3SK228XR-TR	G4802287		1-	A	F3
Q 1013	IC				M67746-01	G1092992		1-	A	C1
Q 1014	TRANSISTOR				2SC5107-O(TE85R)	G3351077O		1-	A	E4
Q 1015	FET				2SK520-T2B K41	G3805207A		1-	A	E5
Q 1016	TRANSISTOR				RT1N241M-T11-1	G3070249		1-	A	D4
Q 1017	TRANSISTOR				IMH6A T108	G3070066		1-	A	E4
Q 1018	TRANSISTOR				2SC5107-O(TE85R)	G3351077O		1-	A	E4
Q 1019	TRANSISTOR				2SC5107-O(TE85R)	G3351077O		1-	B	c4
Q 1020	TRANSISTOR				2SC2954-T2	G3329547		1-	B	d2
Q 1021	TRANSISTOR				2SC5107-O(TE85R)	G3351077O		1-	B	d4
Q 1022	TRANSISTOR				2SC5415E-TD	G3354158E		1-	B	e3
Q 1023	IC				NJM78L05UA TE1	G1091325		1-	B	a5
Q 1024	IC				SA7025DK	G1093014		1-	A	F5
Q 1025	FET				3SK228XR-TR	G4802287		1-	B	b4
Q 1026	IC				TA31136FN(EL)	G1091605		1-	A	G4
Q 1027	TRANSISTOR				2SC4154-T11-1E	G3341548E		1-	B	b4
Q 1028	TRANSISTOR				RT1N241M-T11-1	G3070249		1-	B	a5
Q 1029	TRANSISTOR				2SC4215Y TE85R	G3342157Y		1-	A	F4
Q 1030	IC				MM1216ENRE	G1092432		1-	B	e3
Q 1031	TRANSISTOR				2SA1602A-T11-1F	G3116028F		1-	A	G4
Q 1032	TRANSISTOR				RT1N241M-T11-1	G3070249		1-	A	G4

MAIN Unit

REF.	DESCRIPTION	VALUE	WV	TOL.	MFR'S DESIG	VXSTD P/N	VERS.	LOT.	SIDE	LAY ADR.
Q 1033	TRANSISTOR				RT1N241M-T11-1	G3070249		1-	B	b3
Q 2001	IC				NJM2902V-TE1	G1091679		1-	B	d5
Q 2002	TRANSISTOR				IMZ1 T108	G3070025		1-	B	f5
Q 2003	IC				NJM2902V-TE1	G1091679		1-	B	d4
Q 2004	TRANSISTOR				RT1N241M-T11-1	G3070249		1-	B	g1
Q 2006	TRANSISTOR				RT1N241M-T11-1	G3070249		1-	A	C5
Q 2006	TRANSISTOR				DTC323TK T146	G3070042		4-	A	C5
Q 2007	IC				BU4066BF-E2	G1092593		1-	A	C4
Q 2008	TRANSISTOR				RT1N241M-T11-1	G3070249		1-	B	f5
Q 2009	TRANSISTOR				IMX1 T110	G3070024		1-	B	g5
Q 2011	TRANSISTOR				RT1N241M-T11-1	G3070249		1-	A	B5
Q 2012	TRANSISTOR				DTC323TK T146	G3070042		1-	A	A3
Q 2013	IC				MX165CDW-TR	G1092775		1-	B	e4
Q 2014	IC				CXA1846N-T4	G1092690		1-	A	D4
Q 2015	TRANSISTOR				DTB123EK T146	G3070022		1-	B	f3
Q 2016	IC				BU4053BCF-E2	G1092723		1-	B	e5
Q 2018	TRANSISTOR				2SC4154-T11-1E	G3341548E		1-	A	A4
Q 2019	IC				MB90F583B R0509	G1093508		1-	A	B4
Q 2019	IC				MB90F583B R0526	G1093538		3-	A	B4
Q 2019	IC				MB90F583B(FLASH)	G1093208		10-	A	B4
Q 2020	FET				2SJ327-Z-E1	G4070010		1-	B	f2
Q 2024	IC				NJM78L05UA TE1	G1091325		1-	B	f2
Q 2025	TRANSISTOR				2SA1602A-T11-1F	G3116028F		1-	B	f2
Q 2026	TRANSISTOR				RT1N241M-T11-1	G3070249		1-	B	f2
Q 2027	IC				S-80735SN-DZ-T1	G1091876		1-	B	f2
Q 2027	IC				S-80835CNMC-B8U-T2	G1093606		13-	B	f2
Q 2028	IC				HN58X2432TI	G1093315		1-	A	C4
Q 2029	IC				TDA7240AV	G1091020		1-	A	A3
Q 2108	IC				NJM2902V-TE1	G1091679		1-	B	e5
Q 2110	IC				NJM2902V-TE1	G1091679		1-	B	d5
Q 2111	TRANSISTOR				DTB123EK T146	G3070022		1-	B	g5
Q 2112	TRANSISTOR				IMD3 T108	G3070053		1-	A	A4
Q 2114	TRANSISTOR				RT1N241M-T11-1	G3070249		1-	B	g1
Q 2115	TRANSISTOR				IMD3 T108	G3070053		1-	B	g4
Q 2116	TRANSISTOR				RT1N241M-T11-1	G3070249		1-	A	B5
Q 2117	IC				TC4W53FU TE12L	G1091675		1-	A	A5
Q 2118	TRANSISTOR				RT1N241M-T11-1	G3070249		1-	B	e4
Q 2119	TRANSISTOR				RT1N241M-T11-1	G3070249		1-	A	B5
Q 2120	TRANSISTOR				RT1N241M-T11-1	G3070249		1-	B	e4
Q 2121	TRANSISTOR				RT1N241M-T11-1	G3070249		1-	B	e4
Q 2122	TRANSISTOR				RT1N241M-T11-1	G3070249		1-	B	e4
Q 2124	TRANSISTOR				RT1N241M-T11-1	G3070249		1-	A	D5
Q 2125	TRANSISTOR				RT1N241M-T11-1	G3070249		1-	B	g4
Q 2127	TRANSISTOR				RT1N241M-T11-1	G3070249		4-	B	f3
R 1001	CHIP RES.	47k	1/16W	5%	RMC1/16 473JATP	J24185473		1-	A	G1
R 1002	CHIP RES.	10k	1/16W	5%	RMC1/16 103JATP	J24185103		1-	A	D3
R 1003	CHIP RES.	10k	1/16W	5%	RMC1/16 103JATP	J24185103		1-	A	D3
R 1004	CHIP RES.	220k	1/16W	5%	RMC1/16 224JATP	J24185224		1-	A	D2
R 1005	CHIP RES.	1k	1/16W	5%	RMC1/16 102JATP	J24185102		1-	A	D2
R 1006	CHIP RES.	470	1/16W	5%	RMC1/16 471JATP	J24185471		1-	A	D3
R 1007	CHIP RES.	220k	1/16W	5%	RMC1/16 224JATP	J24185224		1-	A	D2
R 1008	CHIP RES.	100k	1/16W	5%	RMC1/16 104JATP	J24185104		1-	B	d3
R 1009	CHIP RES.	100k	1/16W	5%	RMC1/16 104JATP	J24185104		1-	B	d3
R 1010	CHIP RES.	1k	1/16W	5%	RMC1/16 102JATP	J24185102		1-	A	D2
R 1011	CHIP RES.	2.2k	1/16W	5%	RMC1/16 222JATP	J24185222		1-	B	d3
R 1012	CHIP RES.	10k	1/16W	5%	RMC1/16 103JATP	J24185103		1-	B	d3
R 1013	CHIP RES.	1k	1/16W	5%	RMC1/16 102JATP	J24185102		1-	A	D3
R 1014	CHIP RES.	1k	1/16W	5%	RMC1/16 102JATP	J24185102		1-	A	D2
R 1015	CHIP RES.	220k	1/16W	5%	RMC1/16 224JATP	J24185224		1-	A	D3
R 1016	CHIP RES.	47	1/16W	5%	RMC1/16 470JATP	J24185470		1-	A	D3

※ Requires Firmware, CE35 and FIF-8.

REF.	DESCRIPTION	VALUE	WV	TOL.	MFR'S DESIG	VXSTD P/N	VERS.	LOT.	SIDE	LAY ADR.
R 1017	CHIP RES.	100k	1/16W	5%	RMC1/16 104JATP	J24185104		1-	B	e3
R 1018	CHIP RES.	1k	1/16W	5%	RMC1/16 102JATP	J24185102		1-	B	d3
R 1019	CHIP RES.	2.2k	1/16W	5%	RMC1/16 222JATP	J24185222		1-	B	e3
R 1020	CHIP RES.	82	1W	5%	RMC1 820JTE	J24305820		1-	B	b2
R 1021	CHIP RES.	220k	1/16W	5%	RMC1/16 224JATP	J24185224		1-	B	c3
R 1022	CHIP RES.	2.2k	1/16W	5%	RMC1/16 222JATP	J24185222		1-	A	D5
R 1023	CHIP RES.	4.7k	1/16W	5%	RMC1/16 472JATP	J24185472		1-	A	F2
R 1024	CHIP RES.	2.2M	1/16W	5%	RMC1/16 225JATP	J24185225		1-	A	F3
R 1025	CHIP RES.	4.7k	1/16W	5%	RMC1/16 472JATP	J24185472		1-	A	F2
R 1026	CHIP RES.	2.2M	1/16W	5%	RMC1/16 225JATP	J24185225		1-	A	F3
R 1027	CHIP RES.	1k	1/16W	5%	RMC1/16 102JATP	J24185102		1-	A	E5
R 1029	CHIP RES.	56k	1/16W	5%	RMC1/16 563JATP	J24185563		1-	A	D5
R 1030	CHIP RES.	100	1/2W	5%	RMC1/2 101JCTP	J24275101		1-	B	c2
R 1031	CHIP RES.	47k	1/16W	5%	RMC1/16 473JATP	J24185473		1-	B	d5
R 1032	CHIP RES.	330	1/16W	5%	RMC1/16 331JATP	J24185331		1-	A	E5
R 1033	CHIP RES.	4.7k	1/16W	5%	RMC1/16 472JATP	J24185472		1-	B	d5
R 1034	CHIP RES.	100	1/2W	5%	RMC1/2 101JCTP	J24275101		1-	B	b2
R 1035	CHIP RES.	33k	1/16W	5%	RMC1/16 333JATP	J24185333		1-	A	E5
R 1036	CHIP RES.	4.7k	1/16W	5%	RMC1/16 472JATP	J24185472		1-	B	c2
R 1037	CHIP RES.	22k	1/16W	5%	RMC1/16 223JATP	J24185223		1-	A	D5
R 1038	CHIP RES.	4.7k	1/16W	5%	RMC1/16 472JATP	J24185472		1-	B	c2
R 1039	CHIP RES.	220k	1/16W	5%	RMC1/16 224JATP	J24185224		1-	A	D5
R 1040	CHIP RES.	330k	1/16W	5%	RMC1/16 334JATP	J24185334		1-	A	D5
R 1041	CHIP RES.	22k	1/16W	5%	RMC1/16 223JATP	J24185223		1-	A	F3
R 1042	CHIP RES.	680	1/16W	5%	RMC1/16 681JATP	J24185681		1-	A	F3
R 1043	CHIP RES.	2.2k	1/16W	5%	RMC1/16 222JATP	J24185222		1-	B	b3
R 1044	CHIP RES.	4.7k	1/16W	5%	RMC1/16 472JATP	J24185472		1-	A	E5
R 1046	CHIP RES.	82	1/16W	5%	RMC1/16 820JATP	J24185820		1-	A	F3
R 1048	CHIP RES.	4.7k	1/16W	5%	RMC1/16 472JATP	J24185472		1-	A	E4
R 1049	CHIP RES.	10k	1/16W	5%	RMC1/16 103JATP	J24185103		1-	A	E4
R 1050	CHIP RES.	0	1/8W	5%	RMC1/8T 000J	J24215000		1-	B	d2
R 1051	CHIP RES.	10	1/16W	5%	RMC1/16 100JATP	J24185100		1-	A	F3
R 1054	CHIP RES.	4.7k	1/16W	5%	RMC1/16 472JATP	J24185472		1-	A	E5
R 1055	CHIP RES.	470	1/10W	5%	RMC1/10T 471J	J24205471		1-3	B	d2
R 1055	CHIP RES.	470	1/10W	5%	RMC1/10T 471J	J24205471	VERSION A	4-	B	d2
R 1055	CHIP RES.	180	1/10W	5%	RMC1/10T 181J	J24205181	VERSION C	4-	B	d2
R 1056	CHIP RES.	1k	1/16W	5%	RMC1/16 102JATP	J24185102		1-	A	E4
R 1057	CHIP RES.	47	1/16W	5%	RMC1/16 470JATP	J24185470		1-	A	E4
R 1058	CHIP RES.	270	1/16W	5%	RMC1/16 271JATP	J24185271		1-	A	E4
R 1059	CHIP RES.	0	1/16W	5%	RMC1/16 000JATP	J24185000		1-	A	E5
R 1060	CHIP RES.	22	1/10W	5%	RMC1/10T 220J	J24205220		1-3	B	d2
R 1060	CHIP RES.	22	1/10W	5%	RMC1/10T 220J	J24205220	VERSION A	4-	B	d2
R 1060	CHIP RES.	56	1/10W	5%	RMC1/10T 560J	J24205560	VERSION C	4-	B	d2
R 1061	CHIP RES.	22	1/10W	5%	RMC1/10T 220J	J24205220		1-3	B	d2
R 1061	CHIP RES.	22	1/10W	5%	RMC1/10T 220J	J24205220	VERSION A	4-	B	d2
R 1061	CHIP RES.	56	1/10W	5%	RMC1/10T 560J	J24205560	VERSION C	4-	B	d2
R 1062	CHIP RES.	3.3k	1/16W	5%	RMC1/16 332JATP	J24185332		1-	A	E5
R 1063	CHIP RES.	270	1/16W	5%	RMC1/16 271JATP	J24185271		1-	A	E5
R 1064	CHIP RES.	4.7k	1/16W	5%	RMC1/16 472JATP	J24185472		1-	A	E4
R 1065	CHIP RES.	470	1/10W	5%	RMC1/10T 471J	J24205471		1-3	B	d2
R 1065	CHIP RES.	470	1/10W	5%	RMC1/10T 471J	J24205471	VERSION A	4-	B	d2
R 1065	CHIP RES.	180	1/10W	5%	RMC1/10T 181J	J24205181	VERSION C	4-	B	d2
R 1067	CHIP RES.	100	1/16W	5%	RMC1/16 101JATP	J24185101		1-	A	E4
R 1068	CHIP RES.	0	1/16W	5%	RMC1/16 000JATP	J24185000		1-	A	F5
R 1069	CHIP RES.	10k	1/16W	5%	RMC1/16 103JATP	J24185103		1-	A	E4
R 1070	CHIP RES.	10k	1/16W	5%	RMC1/16 103JATP	J24185103		1-	A	E4
R 1072	CHIP RES.	10	1/4W	5%	RMC1/4 100JATP	J24245100		1-3	A	C2
R 1072	CHIP RES.	10	1/4W	5%	RMC1/4 100JATP	J24245100	VERSION A	4-	A	C2
R 1073	CHIP RES.	2.2M	1/16W	5%	RMC1/16 225JATP	J24185225		1-	A	E3
R 1074	CHIP RES.	560	1/16W	5%	RMC1/16 561JATP	J24185561		1-	A	E4

MAIN Unit

REF.	DESCRIPTION	VALUE	WV	TOL.	MFR'S DESIG	VXSTD P/N	VERS.	LOT.	SIDE	LAY ADR.
R 1075	CHIP RES.	2.2M	1/16W	5%	RMC1/16 225JATP	J24185225		1-	A	E3
R 1076	CHIP RES.	10	1/4W	5%	RMC1/4 100JATP	J24245100		1-	B	e2
R 1077	CHIP RES.	180k	1/16W	5%	RMC1/16 184JATP	J24185184		1-	B	c4
R 1078	CHIP RES.	15	1/16W	5%	RMC1/16 150JATP	J24185150		1-	B	c4
R 1079	CHIP RES.	47	1/16W	5%	RMC1/16 470JATP	J24185470		1-	B	c4
R 1080	CHIP RES.	15	1/16W	5%	RMC1/16 150JATP	J24185150		1-	B	c4
R 1081	CHIP RES.	100	1/16W	5%	RMC1/16 101JATP	J24185101		1-	B	e2
R 1082	CHIP RES.	220	1/16W	5%	RMC1/16 221JATP	J24185221		1-	B	b4
R 1083	CHIP RES.	330	1/16W	5%	RMC1/16 331JATP	J24185331		1-	B	b5
R 1084	CHIP RES.	47k	1/16W	5%	RMC1/16 473JATP	J24185473		1-	B	d4
R 1085	CHIP RES.	47	1/10W	5%	RMC1/10T 470J	J24205470		1-	A	C2
R 1086	CHIP RES.	330	1/16W	5%	RMC1/16 331JATP	J24185331		1-	B	d4
R 1087	CHIP RES.	10k	1/16W	5%	RMC1/16 103JATP	J24185103		1-	B	e3
R 1088	CHIP RES.	22	1/16W	5%	RMC1/16 220JATP	J24185220		1-	B	b5
R 1089	CHIP RES.	330	1/16W	5%	RMC1/16 331JATP	J24185331		1-	B	c4
R 1090	CHIP RES.	1k	1/16W	5%	RMC1/16 102JATP	J24185102		1-	B	b4
R 1091	CHIP RES.	330	1/16W	5%	RMC1/16 331JATP	J24185331		1-	B	c3
R 1092	CHIP RES.	22k	1/16W	5%	RMC1/16 223JATP	J24185223		1-	B	b5
R 1093	CHIP RES.	3.3k	1/16W	5%	RMC1/16 332JATP	J24185332		1-	B	b5
R 1094	CHIP RES.	1k	1/16W	5%	RMC1/16 102JATP	J24185102		1-	B	b4
R 1095	CHIP RES.	1k	1/16W	5%	RMC1/16 102JATP	J24185102		1-	B	b4
R 1096	CHIP RES.	1M	1/16W	5%	RMC1/16 105JATP	J24185105		1-	B	c4
R 1097	CHIP RES.	1k	1/16W	5%	RMC1/16 102JATP	J24185102		1-	B	b4
R 1098	CHIP RES.	22	1/16W	5%	RMC1/16 220JATP	J24185220		1-	B	b4
R 1099	CHIP RES.	470	1/16W	5%	RMC1/16 471JATP	J24185471		1-	B	b4
R 1100	CHIP RES.	22	1/16W	5%	RMC1/16 220JATP	J24185220		1-	B	b4
R 1101	CHIP RES.	15	1/16W	5%	RMC1/16 150JATP	J24185150		1-	B	b4
R 1102	CHIP RES.	12k	1/16W	5%	RMC1/16 123JATP	J24185123		1-	B	a4
R 1103	CHIP RES.	10k	1/16W	5%	RMC1/16 103JATP	J24185103		1-	A	F5
R 1104	CHIP RES.	270	1/16W	5%	RMC1/16 271JATP	J24185271		1-	A	G4
R 1105	CHIP RES.	2.2k	1/16W	5%	RMC1/16 222JATP	J24185222		1-	B	a5
R 1106	CHIP RES.	12k	1/16W	5%	RMC1/16 123JATP	J24185123		1-	B	a5
R 1107	CHIP RES.	12k	1/16W	5%	RMC1/16 123JATP	J24185123		1-	B	a4
R 1108	CHIP RES.	10k	1/16W	5%	RMC1/16 103JATP	J24185103		1-	B	a4
R 1109	CHIP RES.	220	1/16W	5%	RMC1/16 221JATP	J24185221		1-	A	F4
R 1110	CHIP RES.	12k	1/16W	5%	RMC1/16 123JATP	J24185123		1-	B	a5
R 1111	CHIP RES.	12k	1/16W	5%	RMC1/16 123JATP	J24185123		1-	B	a4
R 1112	CHIP RES.	3.3k	1/16W	5%	RMC1/16 332JATP	J24185332		1-	B	a4
R 1113	CHIP RES.	2.2k	1/16W	5%	RMC1/16 222JATP	J24185222		1-	B	a5
R 1114	CHIP RES.	1k	1/16W	5%	RMC1/16 102JATP	J24185102		1-	B	b4
R 1115	CHIP RES.	220k	1/16W	5%	RMC1/16 224JATP	J24185224		1-	B	b5
R 1116	CHIP RES.	12k	1/16W	5%	RMC1/16 123JATP	J24185123		1-	B	a4
R 1117	CHIP RES.	1k	1/16W	5%	RMC1/16 102JATP	J24185102		1-	B	a4
R 1118	CHIP RES.	47k	1/16W	5%	RMC1/16 473JATP	J24185473		1-	B	b5
R 1119	CHIP RES.	220k	1/16W	5%	RMC1/16 224JATP	J24185224		1-	B	b5
R 1120	CHIP RES.	1k	1/10W	5%	RMC1/10T 102J	J24205102		2-3		
R 1120	CHIP RES.	1k	1/10W	5%	RMC1/10T 102J	J24205102	VERSION C	4-		
R 1121	CHIP RES.	5.6k	1/10W	5%	RMC1/10T 562J	J24205562		2-3		
R 1121	CHIP RES.	5.6k	1/16W	5%	RMC1/16 562JATP	J24185562	VERSION C	4-		
R 1122	CHIP RES.	47k	1/16W	5%	RMC1/16 473JATP	J24185473		1-	B	b4
R 1123	CHIP RES.	47k	1/16W	5%	RMC1/16 473JATP	J24185473		1-	B	b4
R 1125	CHIP RES.	47k	1/16W	5%	RMC1/16 473JATP	J24185473		1-	B	b5
R 1126	CHIP RES.	390	1/16W	5%	RMC1/16 391JATP	J24185391		1-	A	F4
R 1131	CHIP RES.	220k	1/16W	5%	RMC1/16 224JATP	J24185224		1-	A	F4
R 1136	CHIP RES.	220	1/16W	5%	RMC1/16 221JATP	J24185221		1-	A	G4
R 1138	CHIP RES.	120k	1/16W	5%	RMC1/16 124JATP	J24185124		1-	B	b5
R 1144	CHIP RES.	270k	1/16W	5%	RMC1/16 274JATP	J24185274		1-	B	a5
R 1145	CHIP RES.	220k	1/16W	5%	RMC1/16 224JATP	J24185224		1-	B	a5
R 1151	CHIP RES.	22k	1/16W	5%	RMC1/16 223JATP	J24185223		1-	A	F5
R 1152	CHIP RES.	27k	1/16W	5%	RMC1/16 273JATP	J24185273		1-	A	F5

REF.	DESCRIPTION	VALUE	WV	TOL.	MFR'S DESIG	VXSTD P/N	VERS.	LOT.	SIDE	LAY ADR.
R 1153	CHIP RES.	10k	1/16W	5%	RMC1/16 103JATP	J24185103		1-	A	G4
R 1154	CHIP RES.	1k	1/16W	5%	RMC1/16 102JATP	J24185102		1-	A	G4
R 1155	CHIP RES.	2.2k	1/16W	5%	RMC1/16 222JATP	J24185222		1-	A	G4
R 1156	CHIP RES.	2.2k	1/16W	5%	RMC1/16 222JATP	J24185222		1-	A	G4
R 1157	CHIP RES.	1M	1/16W	5%	RMC1/16 105JATP	J24185105		1-	A	F3
R 1158	CHIP RES.	3.3k	1/16W	5%	RMC1/16 332JATP	J24185332		1-	A	F4
R 1159	CHIP RES.	220k	1/16W	5%	RMC1/16 224JATP	J24185224		1-	A	D3
R 1160	CHIP RES.	470k	1/16W	5%	RMC1/16 474JATP	J24185474		1-	A	D3
R 1161	CHIP RES.	10k	1/16W	5%	RMC1/16 103JATP	J24185103		1-	B	b3
R 1162	CHIP RES.	82	1/16W	5%	RMC1/16 820JATP	J24185820		1-	B	b3
R 1163	CHIP RES.	10k	1/16W	5%	RMC1/16 103JATP	J24185103		1-	B	c3
R 1167	CHIP RES.	0	1/16W	5%	RMC1/16 000JATP	J24185000		1-	B	d3
R 1168	CARBON FILM RES.	150	1/4W	5%	RD14SJ151 150	J02245151		1-3	A	C2
R 1168	CHIP RES.	10	1/4W	5%	RMC1/4 100JATP	J24245100	VERSION C	4-	A	C2
R 2003	CHIP RES.	100k	1/16W	5%	RMC1/16 104JATP	J24185104		1-	B	f4
R 2005	CHIP RES.	100k	1/16W	5%	RMC1/16 104JATP	J24185104		1-	B	f4
R 2006	CHIP RES.	330	1/16W	5%	RMC1/16 331JATP	J24185331		1-	B	g3
R 2007	CHIP RES.	330	1/16W	5%	RMC1/16 331JATP	J24185331		1-	B	g1
R 2008	CHIP RES.	10k	1/16W	5%	RMC1/16 103JATP	J24185103		1-	B	g1
R 2009	CHIP RES.	330	1/16W	5%	RMC1/16 331JATP	J24185331		1-	B	f5
R 2010	CHIP RES.	330	1/16W	5%	RMC1/16 331JATP	J24185331		1-	B	f5
R 2011	CHIP RES.	560	1/16W	5%	RMC1/16 561JATP	J24185561		1-	B	f5
R 2012	CHIP RES.	120k	1/16W	5%	RMC1/16 124JATP	J24185124		1-	B	f5
R 2013	CHIP RES.	2.2k	1/16W	5%	RMC1/16 222JATP	J24185222		1-	B	f5
R 2014	CHIP RES.	680	1/16W	5%	RMC1/16 681JATP	J24185681		1-	A	B5
R 2015	CHIP RES.	47k	1/16W	5%	RMC1/16 473JATP	J24185473		1-	A	B5
R 2018	CHIP RES.	680	1/16W	5%	RMC1/16 681JATP	J24185681		1-	B	f5
R 2019	CHIP RES.	0.33	1W	10%	RMC1 R33KATE	J24309001		1-	A	B2
R 2020	CHIP RES.	150k	1/16W	5%	RMC1/16 154JATP	J24185154		1-	B	f5
R 2022	CARBON FILM RES.	2.2	1/6W	5%	RD16UJ2R2 2.2	J02225229		1-	B	g2
R 2022	CHIP RES.	2.2	1/16W	5%	RMC1/16 2R2JATP	J24185229		4-	B	g2
R 2026	CHIP RES.	100k	1/16W	5%	RMC1/16 104JATP	J24185104		1-	B	f4
R 2028	CHIP RES.	100k	1/16W	5%	RMC1/16 104JATP	J24185104		1-	B	f4
R 2029	CHIP RES.	100k	1/16W	5%	RMC1/16 104JATP	J24185104		1-	A	C4
R 2030	CHIP RES.	10k	1/16W	5%	RMC1/16 103JATP	J24185103		1-	B	g4
R 2031	CHIP RES.	10k	1/16W	5%	RMC1/16 103JATP	J24185103		1-	B	g1
R 2032	CHIP RES.	680	1/16W	5%	RMC1/16 681JATP	J24185681		1-	A	A1
R 2033	CHIP RES.	4.7k	1/16W	5%	RMC1/16 472JATP	J24185472		1-	B	g5
R 2034	CHIP RES.	4.7k	1/16W	5%	RMC1/16 472JATP	J24185472		1-	B	g5
R 2035	CHIP RES.	100k	1/16W	5%	RMC1/16 104JATP	J24185104		1-	B	e5
R 2036	CHIP RES.	22k	1/16W	5%	RMC1/16 223JATP	J24185223		1-	B	e5
R 2037	CHIP RES.	120k	1/16W	5%	RMC1/16 124JATP	J24185124		1-	B	e5
R 2038	CHIP RES.	4.7k	1/16W	5%	RMC1/16 472JATP	J24185472		1-	B	f5
R 2039	CHIP RES.	100k	1/16W	5%	RMC1/16 104JATP	J24185104		1-	A	C5
R 2040	CHIP RES.	2.2k	1/16W	5%	RMC1/16 222JATP	J24185222		1-	B	e5
R 2041	CHIP RES.	39k	1/16W	5%	RMC1/16 393JATP	J24185393		1-	B	e5
R 2042	CHIP RES.	220k	1/16W	5%	RMC1/16 224JATP	J24185224		1-	B	g2
R 2043	CHIP RES.	10k	1/16W	5%	RMC1/16 103JATP	J24185103		1-	B	f5
R 2044	CHIP RES.	270k	1/16W	5%	RMC1/16 274JATP	J24185274		1-	B	f5
R 2047	CHIP RES.	470k	1/16W	5%	RMC1/16 474JATP	J24185474		1-3	B	g3
R 2048	CHIP RES.	22k	1/16W	5%	RMC1/16 223JATP	J24185223		1-	A	A3
R 2050	CHIP RES.	2.7k	1/16W	5%	RMC1/16 272JATP	J24185272		1-	B	f2
R 2051	CHIP RES.	47k	1/16W	5%	RMC1/16 473JATP	J24185473		1-	B	g3
R 2051	CHIP RES.	2.2M	1/16W	5%	RMC1/16 225JATP	J24185225		4-	B	g3
R 2052	CHIP RES.	680	1/16W	5%	RMC1/16 681JATP	J24185681		1-	A	A2
R 2053	CHIP RES.	470	1/16W	5%	RMC1/16 471JATP	J24185471		1-	A	C4
R 2054	CHIP RES.	47k	1/16W	5%	RMC1/16 473JATP	J24185473		1-	B	f3
R 2055	CHIP RES.	4.7k	1/16W	5%	RMC1/16 472JATP	J24185472		1-	B	f5
R 2056	CHIP RES.	4.7k	1/16W	5%	RMC1/16 472JATP	J24185472		1-	B	f5
R 2057	CHIP RES.	5.6k	1/16W	5%	RMC1/16 562JATP	J24185562		1-	A	B5

MAIN Unit

REF.	DESCRIPTION	VALUE	WV	TOL.	MFR'S DESIG	VXSTD P/N	VERS.	LOT.	SIDE	LAY ADR.
R 2058	CHIP RES.	10k	1/16W	5%	RMC1/16 103JATP	J24185103		1-	B	e4
R 2059	CHIP RES.	22k	1/16W	5%	RMC1/16 223JATP	J24185223		1-	B	e5
R 2060	CHIP RES.	10k	1/16W	5%	RMC1/16 103JATP	J24185103		1-	A	C5
R 2061	CHIP RES.	100k	1/16W	5%	RMC1/16 104JATP	J24185104		1-	B	e5
R 2062	CHIP RES.	0	1/16W	5%	RMC1/16 000JATP	J24185000		1-	B	f3
R 2063	CHIP RES.	10k	1/16W	5%	RMC1/16 103JATP	J24185103		1-	B	e4
R 2064	CHIP RES.	15k	1/16W	5%	RMC1/16 153JATP	J24185153		1-	B	e4
R 2065	CHIP RES.	1k	1/16W	5%	RMC1/16 102JATP	J24185102		1-	A	A3
R 2066	CHIP RES.	10k	1/16W	5%	RMC1/16 103JATP	J24185103		1-	B	g3
R 2067	CHIP RES.	10k	1/16W	5%	RMC1/16 103JATP	J24185103		1-	B	g3
R 2068	CHIP RES.	47	1/16W	5%	RMC1/16 470JATP	J24185470		1-	A	D4
R 2069	CHIP RES.	47k	1/16W	5%	RMC1/16 473JATP	J24185473		1-	B	d4
R 2070	CHIP RES.	10k	1/16W	5%	RMC1/16 103JATP	J24185103		1-	A	D4
R 2071	CHIP RES.	10k	1/16W	5%	RMC1/16 103JATP	J24185103		1-	A	D4
R 2072	CHIP RES.	220k	1/16W	5%	RMC1/16 224JATP	J24185224		1-	A	C5
R 2073	CHIP RES.	100k	1/16W	5%	RMC1/16 104JATP	J24185104		1-	A	C5
R 2074	CHIP RES.	150k	1/16W	5%	RMC1/16 154JATP	J24185154		1-	B	d5
R 2075	CHIP RES.	1M	1/16W	5%	RMC1/16 105JATP	J24185105		1-	B	d4
R 2076	CHIP RES.	150k	1/16W	5%	RMC1/16 154JATP	J24185154		1-	B	d4
R 2077	CHIP RES.	1M	1/16W	5%	RMC1/16 105JATP	J24185105		1-	A	C5
R 2078	CHIP RES.	1M	1/16W	5%	RMC1/16 105JATP	J24185105		1-	A	C4
R 2079	CHIP RES.	47k	1/16W	5%	RMC1/16 473JATP	J24185473		1-	A	D5
R 2080	CHIP RES.	2.2k	1/16W	5%	RMC1/16 222JATP	J24185222		1-	A	D4
R 2081	CHIP RES.	3.3k	1/16W	5%	RMC1/16 332JATP	J24185332		1-	B	d4
R 2082	CHIP RES.	10k	1/16W	5%	RMC1/16 103JATP	J24185103		1-	B	d4
R 2083	CHIP RES.	47	1/16W	5%	RMC1/16 470JATP	J24185470		1-	B	e3
R 2084	CHIP RES.	10k	1/16W	5%	RMC1/16 103JATP	J24185103		1-	A	B4
R 2085	CHIP RES.	22k	1/16W	5%	RMC1/16 223JATP	J24185223		1-	A	B4
R 2086	CHIP RES.	18k	1/16W	5%	RMC1/16 183JATP	J24185183		1-	A	B4
R 2087	CHIP RES.	39k	1/16W	5%	RMC1/16 393JATP	J24185393		1-	A	B4
R 2088	CHIP RES.	10k	1/16W	5%	RMC1/16 103JATP	J24185103		1-	A	B4
R 2089	CHIP RES.	15k	1/16W	5%	RMC1/16 153JATP	J24185153		1-	A	C5
R 2090	CHIP RES.	12k	1/16W	5%	RMC1/16 123JATP	J24185123		1-	A	C5
R 2091	CHIP RES.	39k	1/16W	5%	RMC1/16 393JATP	J24185393		1-	B	e5
R 2092	CHIP RES.	680k	1/16W	5%	RMC1/16 684JATP	J24185684		1-	B	e5
R 2093	CHIP RES.	10k	1/16W	5%	RMC1/16 103JATP	J24185103		1-	A	C5
R 2094	CHIP RES.	39k	1/16W	5%	RMC1/16 393JATP	J24185393		1-	A	D4
R 2095	CHIP RES.	330k	1/16W	5%	RMC1/16 334JATP	J24185334		1-	B	d5
R 2096	CHIP RES.	2.2M	1/16W	5%	RMC1/16 225JATP	J24185225		1-	B	d5
R 2097	CHIP RES.	5.6k	1/16W	5%	RMC1/16 562JATP	J24185562		1-	A	D5
R 2098	CHIP RES.	470k	1/16W	5%	RMC1/16 474JATP	J24185474		1-	B	d4
R 2099	CHIP RES.	150k	1/16W	5%	RMC1/16 154JATP	J24185154		1-	B	d4
R 2100	CHIP RES.	180k	1/16W	5%	RMC1/16 184JATP	J24185184		1-	B	d5
R 2101	CHIP RES.	180k	1/16W	5%	RMC1/16 184JATP	J24185184		1-	B	d4
R 2102	CHIP RES.	15k	1/16W	5%	RMC1/16 153JATP	J24185153		1-	A	D4
R 2103	CHIP RES.	12k	1/16W	5%	RMC1/16 123JATP	J24185123		1-	A	D4
R 2104	CHIP RES.	150k	1/16W	5%	RMC1/16 154JATP	J24185154		1-	B	d4
R 2105	CHIP RES.	0	1/16W	5%	RMC1/16 000JATP	J24185000		1-	B	d4
R 2106	CHIP RES.	180	1/16W	5%	RMC1/16 181JATP	J24185181		1-	A	D4
R 2107	CHIP RES.	2.2k	1/16W	5%	RMC1/16 222JATP	J24185222		1-	B	d4
R 2108	CHIP RES.	0	1/16W	5%	RMC1/16 000JATP	J24185000		1-	A	D4
R 2109	CHIP RES.	150k	1/16W	5%	RMC1/16 154JATP	J24185154		1-	B	d4
R 2110	CHIP RES.	10k	1/16W	5%	RMC1/16 103JATP	J24185103		1-	B	d4
R 2111	CHIP RES.	2.2M	1/16W	5%	RMC1/16 225JATP	J24185225		1-	A	C4
R 2112	CHIP RES.	330k	1/16W	5%	RMC1/16 334JATP	J24185334		1-	A	C4
R 2113	CHIP RES.	10k	1/16W	5%	RMC1/16 103JATP	J24185103		1-	A	D4
R 2114	CHIP RES.	82k	1/16W	5%	RMC1/16 823JATP	J24185823		1-	A	C5
R 2115	CHIP RES.	10k	1/16W	5%	RMC1/16 103JATP	J24185103		1-	A	C5
R 2116	CHIP RES.	18k	1/16W	5%	RMC1/16 183JATP	J24185183		1-	A	C5
R 2117	CHIP RES.	12k	1/16W	5%	RMC1/16 123JATP	J24185123		1-	A	D5

REF.	DESCRIPTION	VALUE	WV	TOL.	MFR'S DESIG	VXSTD P/N	VERS.	LOT.	SIDE	LAY ADR.
R 2118	CHIP RES.	820k	1/16W	5%	RMC1/16 824JATP	J24185824		1-	A	C5
R 2119	CHIP RES.	680k	1/16W	5%	RMC1/16 684JATP	J24185684		1-	B	e5
R 2120	CHIP RES.	1.2k	1/16W	5%	RMC1/16 122JATP	J24185122		1-	B	e5
R 2121	CHIP RES.	15k	1/16W	5%	RMC1/16 153JATP	J24185153		1-	B	e4
R 2122	CHIP RES.	470k	1/16W	5%	RMC1/16 474JATP	J24185474		1-	B	e5
R 2123	CHIP RES.	470k	1/16W	5%	RMC1/16 474JATP	J24185474		1-	B	d5
R 2124	CHIP RES.	330k	1/16W	5%	RMC1/16 334JATP	J24185334		1-	B	d5
R 2125	CHIP RES.	330k	1/16W	5%	RMC1/16 334JATP	J24185334		1-	B	d5
R 2126	CHIP RES.	1M	1/16W	5%	RMC1/16 105JATP	J24185105		1-	B	d5
R 2127	CHIP RES.	330k	1/16W	5%	RMC1/16 334JATP	J24185334		1-	B	d5
R 2128	CHIP RES.	1M	1/16W	5%	RMC1/16 105JATP	J24185105		1-	B	g4
R 2129	CHIP RES.	180k	1/16W	5%	RMC1/16 184JATP	J24185184		1-	B	d5
R 2130	CHIP RES.	1k	1/16W	5%	RMC1/16 102JATP	J24185102		1-	B	d4
R 2131	CHIP RES.	180	1/16W	5%	RMC1/16 181JATP	J24185181		1-	B	d4
R 2133	CHIP RES.	47k	1/16W	5%	RMC1/16 473JATP	J24185473		1-	B	f4
R 2134	CHIP RES.	10k	1/16W	5%	RMC1/16 103JATP	J24185103		1-	A	D4
R 2135	CHIP RES.	680k	1/16W	5%	RMC1/16 684JATP	J24185684		1-	B	d4
R 2136	CHIP RES.	180k	1/16W	5%	RMC1/16 184JATP	J24185184		1-	B	d4
R 2137	CHIP RES.	100k	1/16W	5%	RMC1/16 104JATP	J24185104		1-	B	d4
R 2138	CHIP RES.	6.8k	1/16W	5%	RMC1/16 682JATP	J24185682		1-	B	d4
R 2139	CHIP RES.	1.5M	1/16W	5%	RMC1/16 155JATP	J24185155		1-	A	D4
R 2140	CHIP RES.	10k	1/16W	5%	RMC1/16 103JATP	J24185103		1-	A	C4
R 2141	CHIP RES.	180k	1/16W	5%	RMC1/16 184JATP	J24185184		1-	A	C3
R 2142	CHIP RES.	100k	1/16W	5%	RMC1/16 104JATP	J24185104		1-	B	e5
R 2143	CHIP RES.	120k	1/16W	5%	RMC1/16 124JATP	J24185124		1-	B	e5
R 2144	CHIP RES.	120k	1/16W	5%	RMC1/16 124JATP	J24185124		1-	B	e5
R 2145	CHIP RES.	10k	1/16W	5%	RMC1/16 103JATP	J24185103		1-	B	d4
R 2146	CHIP RES.	330k	1/16W	5%	RMC1/16 334JATP	J24185334		1-	B	d5
R 2147	CHIP RES.	10k	1/16W	5%	RMC1/16 103JATP	J24185103		1-	B	d4
R 2149	CHIP RES.	15k	1/16W	5%	RMC1/16 153JATP	J24185153		1-	A	A4
R 2150	CHIP RES.	47k	1/16W	5%	RMC1/16 473JATP	J24185473		1-	A	A3
R 2151	CHIP RES.	47k	1/16W	5%	RMC1/16 473JATP	J24185473		1-	B	g4
R 2152	CHIP RES.	47k	1/16W	5%	RMC1/16 473JATP	J24185473		1-	B	f4
R 2153	CHIP RES.	47k	1/16W	5%	RMC1/16 473JATP	J24185473		1-	B	f4
R 2154	CHIP RES.	10k	1/16W	5%	RMC1/16 103JATP	J24185103		1-	B	d5
R 2155	CHIP RES.	100k	1/16W	5%	RMC1/16 104JATP	J24185104		1-	B	d5
R 2156	CHIP RES.	120k	1/16W	5%	RMC1/16 124JATP	J24185124		1-	B	d5
R 2157	CHIP RES.	10k	1/16W	5%	RMC1/16 103JATP	J24185103		1-	B	e4
R 2158	CHIP RES.	10k	1/16W	5%	RMC1/16 103JATP	J24185103		1-	B	e4
R 2159	CHIP RES.	10k	1/16W	5%	RMC1/16 103JATP	J24185103		1-	B	e4
R 2160	CHIP RES.	47k	1/16W	5%	RMC1/16 473JATP	J24185473		1-	B	f2
R 2162	CHIP RES.	1k	1/16W	5%	RMC1/16 102JATP	J24185102		1-	B	f2
R 2166	CHIP RES.	0	1/16W	5%	RMC1/16 000JATP	J24185000		1-	A	D5
R 2168	CHIP RES.	10k	1/16W	5%	RMC1/16 103JATP	J24185103		1-	B	g4
R 2169	CHIP RES.	10k	1/16W	5%	RMC1/16 103JATP	J24185103		1-	A	D5
R 2170	CHIP RES.	39k	1/16W	5%	RMC1/16 393JATP	J24185393		1-	B	d5
R 2171	CHIP RES.	10k	1/16W	5%	RMC1/16 103JATP	J24185103		1-	B	d5
R 2172	CHIP RES.	22k	1/16W	5%	RMC1/16 223JATP	J24185223		1-	B	d5
R 2175	CHIP RES.	15k	1/16W	5%	RMC1/16 153JATP	J24185153		1-	B	f2
R 2176	CHIP RES.	220k	1/16W	5%	RMC1/16 224JATP	J24185224		1-	B	f2
R 2177	CHIP RES.	15k	1/16W	5%	RMC1/16 153JATP	J24185153		1-	B	f2
R 2178	CHIP RES.	47k	1/16W	5%	RMC1/16 473JATP	J24185473		1-	B	f2
R 2179	CHIP RES.	10k	1/16W	5%	RMC1/16 103JATP	J24185103		1-	A	A3
R 2180	CHIP RES.	47k	1/16W	5%	RMC1/16 473JATP	J24185473		1-	B	f3
R 2182	CHIP RES.	47k	1/16W	5%	RMC1/16 473JATP	J24185473		1-	B	f3
R 2183	CHIP RES.	220k	1/16W	5%	RMC1/16 224JATP	J24185224		1-	B	g4
R 2184	CHIP RES.	10k	1/16W	5%	RMC1/16 103JATP	J24185103		1-	B	g4
R 2185	CHIP RES.	100k	1/16W	5%	RMC1/16 104JATP	J24185104		1-	B	g4
R 2187	CHIP RES.	120k	1/16W	5%	RMC1/16 124JATP	J24185124		1-	A	D5
R 2188	CHIP RES.	56k	1/16W	5%	RMC1/16 563JATP	J24185563		1-	B	d5

MAIN Unit

REF.	DESCRIPTION	VALUE	WV	TOL.	MFR'S DESIG	VXSTD P/N	VERS.	LOT.	SIDE	LAY ADR.
R 2189	CHIP RES.	150k	1/16W	5%	RMC1/16 154JATP	J24185154		1-	A	D5
R 2190	CHIP RES.	150k	1/16W	5%	RMC1/16 154JATP	J24185154		1-	B	d5
R 2191	CHIP RES.	47k	1/16W	5%	RMC1/16 473JATP	J24185473		1-	B	f2
R 2192	CHIP RES.	47k	1/16W	5%	RMC1/16 473JATP	J24185473		1-	B	f2
R 2193	CHIP RES.	47k	1/16W	5%	RMC1/16 473JATP	J24185473		1-	B	f3
R 2195	CHIP RES.	10k	1/16W	5%	RMC1/16 103JATP	J24185103		1-	B	f5
R 2196	CHIP RES.	1k	1/16W	5%	RMC1/16 102JATP	J24185102		1-	A	B3
R 2197	CHIP RES.	33k	1/16W	5%	RMC1/16 333JATP	J24185333		1-	B	g3
R 2198	CHIP RES.	10k	1/16W	5%	RMC1/16 103JATP	J24185103		1-	A	A4
R 2200	CHIP RES.	10k	1/16W	5%	RMC1/16 103JATP	J24185103		1-	B	d5
R 2201	CHIP RES.	10k	1/16W	5%	RMC1/16 103JATP	J24185103		1-	B	f2
R 2202	CHIP RES.	4.7k	1/16W	5%	RMC1/16 472JATP	J24185472		1-	B	f3
R 2203	CHIP RES.	22k	1/16W	5%	RMC1/16 223JATP	J24185223		1-	A	B3
R 2204	CHIP RES.	1k	1/16W	5%	RMC1/16 102JATP	J24185102		1-	A	B4
R 2205	CHIP RES.	470	1/16W	5%	RMC1/16 471JATP	J24185471		1-	B	f5
R 2206	CHIP RES.	4.7k	1/16W	5%	RMC1/16 472JATP	J24185472		1-	B	f5
R 2208	CHIP RES.	330	1/16W	5%	RMC1/16 331JATP	J24185331		1-	B	f1
R 2209	CHIP RES.	470	1/16W	5%	RMC1/16 471JATP	J24185471		1-	B	d4
R 2210	CHIP RES.	10k	1/16W	5%	RMC1/16 103JATP	J24185103		1-	B	d4
R 2211	CHIP RES.	10k	1/16W	5%	RMC1/16 103JATP	J24185103		1-	B	f5
R 2212	CHIP RES.	10k	1/16W	5%	RMC1/16 103JATP	J24185103		1-	B	g4
R 2213	CHIP RES.	2.2k	1/16W	5%	RMC1/16 222JATP	J24185222		1-	B	f5
R 2214	CHIP RES.	4.7k	1/16W	5%	RMC1/16 472JATP	J24185472		1-	B	f5
R 2215	CHIP RES.	4.7k	1/16W	5%	RMC1/16 472JATP	J24185472		1-	B	f5
R 2216	CHIP RES.	4.7k	1/16W	5%	RMC1/16 472JATP	J24185472		1-	B	g5
R 2217	CHIP RES.	4.7k	1/16W	5%	RMC1/16 472JATP	J24185472		1-	B	g5
R 2218	CHIP RES.	4.7k	1/16W	5%	RMC1/16 472JATP	J24185472		1-	B	f5
R 2219	CHIP RES.	1M	1/16W	5%	RMC1/16 105JATP	J24185105		1-	A	C5
R 2221	CHIP RES.	10k	1/16W	5%	RMC1/16 103JATP	J24185103		1-	A	B5
R 2222	CHIP RES.	47k	1/16W	5%	RMC1/16 473JATP	J24185473		1-	A	B5
R 2223	CHIP RES.	10k	1/16W	5%	RMC1/16 103JATP	J24185103		1-	A	C4
R 2224	CHIP RES.	4.7k	1/16W	5%	RMC1/16 472JATP	J24185472		1-	B	d4
R 2227	CHIP RES.	0.33	1W	10%	RMC1 R33KATE	J24309001		1-	A	B2
R 2229	CHIP RES.	1k	1/16W	5%	RMC1/16 102JATP	J24185102		1-	B	f1
R 2230	CHIP RES.	1k	1/16W	5%	RMC1/16 102JATP	J24185102		1-	B	f1
R 2231	CHIP RES.	1k	1/16W	5%	RMC1/16 102JATP	J24185102		1-	B	f1
R 2232	CHIP RES.	1k	1/16W	5%	RMC1/16 102JATP	J24185102		1-	B	f1
R 2234	CHIP RES.	1k	1/16W	5%	RMC1/16 102JATP	J24185102		1-	B	f1
R 2235	CHIP RES.	1k	1/16W	5%	RMC1/16 102JATP	J24185102		1-	B	g1
R 2236	CHIP RES.	1k	1/16W	5%	RMC1/16 102JATP	J24185102		1-	B	g1
R 2237	CHIP RES.	1k	1/16W	5%	RMC1/16 102JATP	J24185102		1-	B	g1
R 2238	CHIP RES.	1k	1/16W	5%	RMC1/16 102JATP	J24185102		1-	B	g1
R 2240	CHIP RES.	1k	1/16W	5%	RMC1/16 102JATP	J24185102		1-	B	g1
R 2241	CHIP RES.	1k	1/16W	5%	RMC1/16 102JATP	J24185102		1-	B	g1
R 2242	CHIP RES.	1k	1/16W	5%	RMC1/16 102JATP	J24185102		1-	B	g1
R 2243	CHIP RES.	1k	1/16W	5%	RMC1/16 102JATP	J24185102		1-9	B	f1
R 2244	CHIP RES.	1k	1/16W	5%	RMC1/16 102JATP	J24185102		1-	B	f1
R 2245	CHIP RES.	180k	1/16W	5%	RMC1/16 184JATP	J24185184		1-	B	f2
R 2246	CHIP RES.	47k	1/16W	5%	RMC1/16 473JATP	J24185473		1-	A	B4
R 2247	CHIP RES.	10	1/4W	5%	RMC1/4 100JATP	J24245100		1-	B	f2
R 2248	CHIP RES.	15k	1/16W	5%	RMC1/16 153JATP	J24185153		1-	A	C5
R 2249	CHIP RES.	4.7k	1/16W	5%	RMC1/16 472JATP	J24185472		1-	A	C5
R 2250	CHIP RES.	2.2k	1/16W	5%	RMC1/16 222JATP	J24185222		1-	A	D5
R 2251	CHIP RES.	2.2k	1/16W	5%	RMC1/16 222JATP	J24185222		1-	A	D5
R 2254	CHIP RES.	0	1/16W	5%	RMC1/16 000JATP	J24185000		1-	B	g1
R 2255	CHIP RES.	0	1/16W	5%	RMC1/16 000JATP	J24185000		1-	B	g1
R 2256	CHIP RES.	470	1/16W	5%	RMC1/16 471JATP	J24185471		1-	B	f1
R 2257	CHIP RES.	0	1/16W	5%	RMC1/16 000JATP	J24185000		1-	B	f1
R 2258	CHIP RES.	0	1/16W	5%	RMC1/16 000JATP	J24185000		1-	B	g1
R 2259	CHIP RES.	0	1/16W	5%	RMC1/16 000JATP	J24185000		1-	B	f1

REF.	DESCRIPTION	VALUE	WV	TOL.	MFR'S DESIG	VXSTD P/N	VERS.	LOT.	SIDE	LAY ADR.
R 2260	CHIP RES.	47k	1/16W	5%	RMC1/16 473JATP	J24185473		1-	B	g4
R 2261	CHIP RES.	47k	1/16W	5%	RMC1/16 473JATP	J24185473		1-	B	f4
R 2262	CHIP RES.	10k	1/16W	5%	RMC1/16 103JATP	J24185103		1-	B	g3
R 2262	CHIP RES.	470k	1/16W	5%	RMC1/16 474JATP	J24185474		4-	B	g3
R 2263	CARBON FILM RES.	47k	1/6W	5%	RD16PJ473 47K	J01225473		1-	B	f4
R 2263	CHIP RES.	47k	1/16W	5%	RMC1/16 473JATP	J24185473		4-	B	f4
R 2264	CARBON FILM RES.	2.2	1/6W	5%	RD16UJ2R2 2.2	J02225229		1-	B	g3
R 2264	CHIP RES.	2.2	1/16W	5%	RMC1/16 2R2JATP	J24185229		4-	A	g3
R 2265	CHIP RES.	4.7k	1/16W	5%	RMC1/16 472JATP	J24185472		4-	A	A5
R 2266	CHIP RES.	10k	1/16W	5%	RMC1/16 103JATP	J24185103		4-	B	e4
R 2267	CHIP RES.	4.7k	1/16W	5%	RMC1/16 472JATP	J24185472		4-	A	B5
R 2268	CARBON FILM RES.	10k	1/6W	5%	RD16PJ103 10K	J01225103		1-		
R 2269	CHIP RES.	1M	1/10W	5%	RMC1/10T 105J	J24205105		2-		
TC1001	TRIMMER CAP.	10pF			ECR-JA010A11X	K91000227		1-	A	F4
TH1002	THERMISTOR				TBPS1R473K475H5Q	G9090068		1-	A	F5
TH1003	THERMISTOR				TBPS1R103K440H5Q	G9090067		1-	A	F5
TH2002	THERMISTOR				TBPS1R104K475H5Q	G9090069		1-	B	a2
X 1001	XTAL TOP-B	14.5MHz			14.5MHZ	H0103196		1-	A	F5
X 2001	XTAL 92SMX(A)	16MHz			16.000MHZ	H0103252		1-	A	A4
XF1001	XTAL FILTER				43Y12B5F	H1102307		1-	A	F4
XF1002	XTAL FILTER				43Y12B5F	H1102307		1-	A	F4
	SHIELD CASE				(A)	RA0073900		5-		
	SHIELD CASE					RA0014200		5-		
	LEAF SPRING					R0140031		5-		

MAIN Unit

Note:

Circuit Diagram

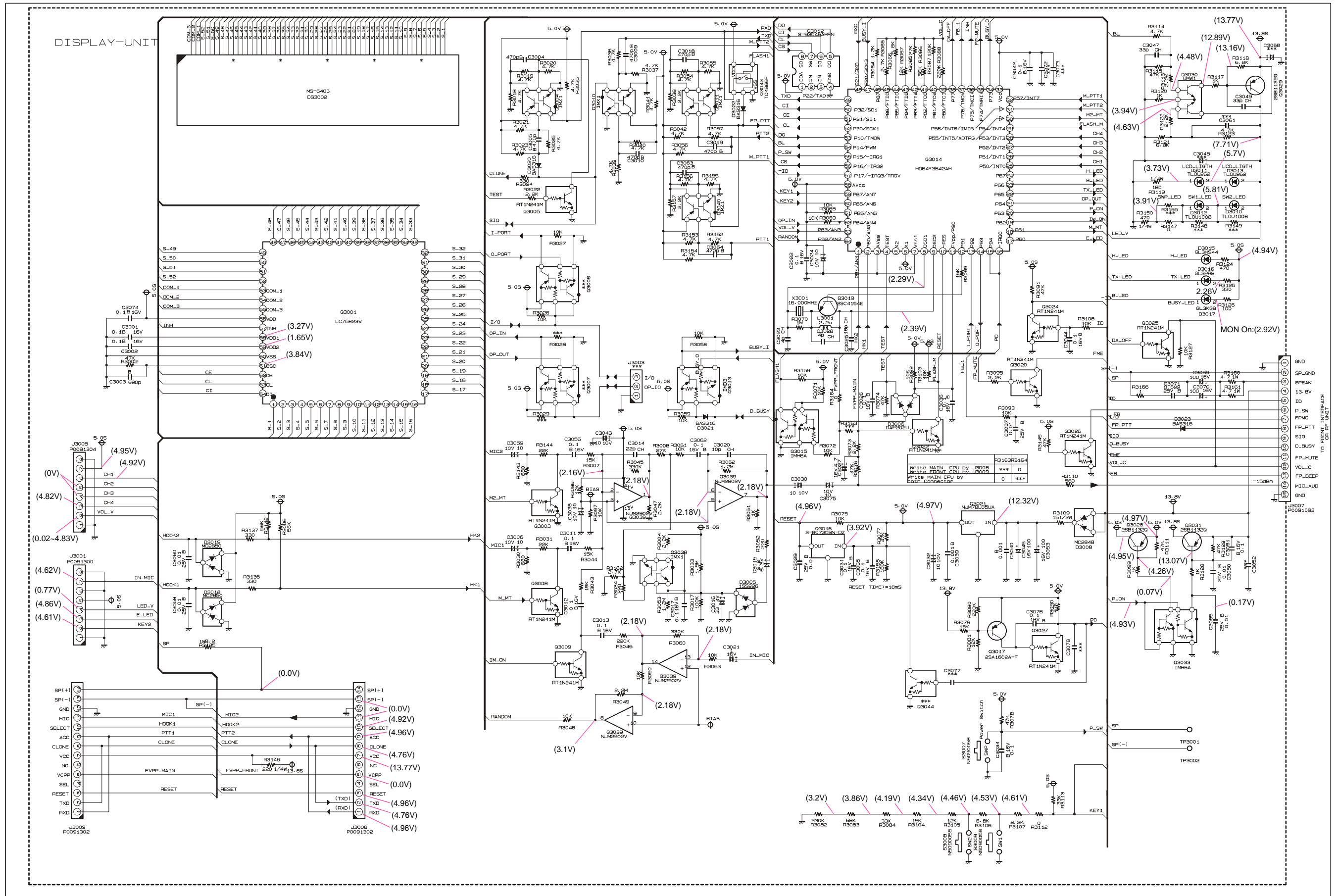

DISPLAY Unit (Lot. 1~)

Note:

Parts Layout

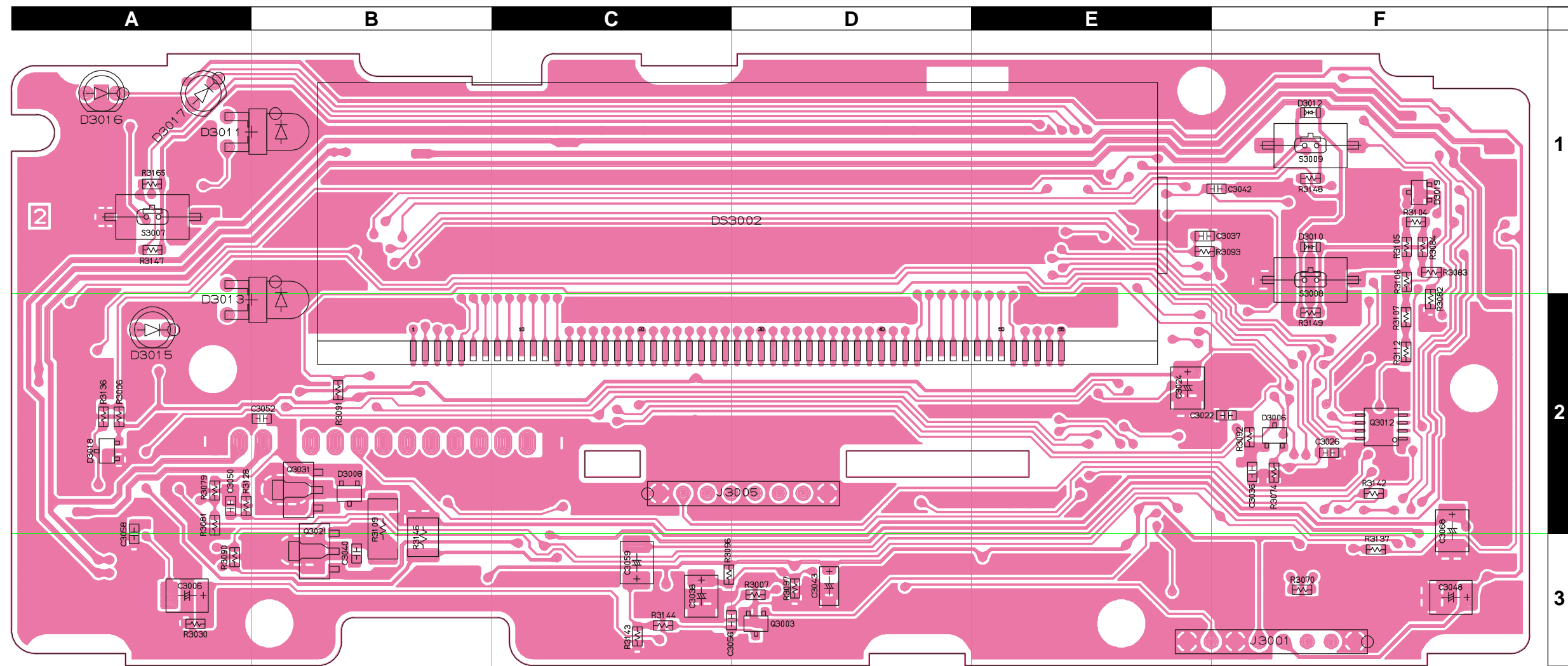

Side A

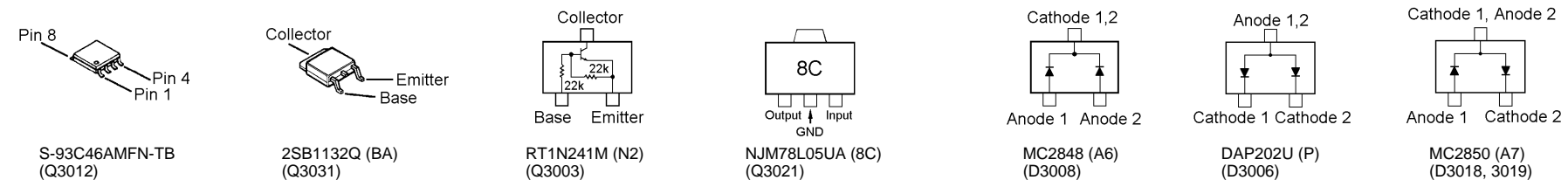

DISPLAY Unit (Lot. 1~)

Parts Layout

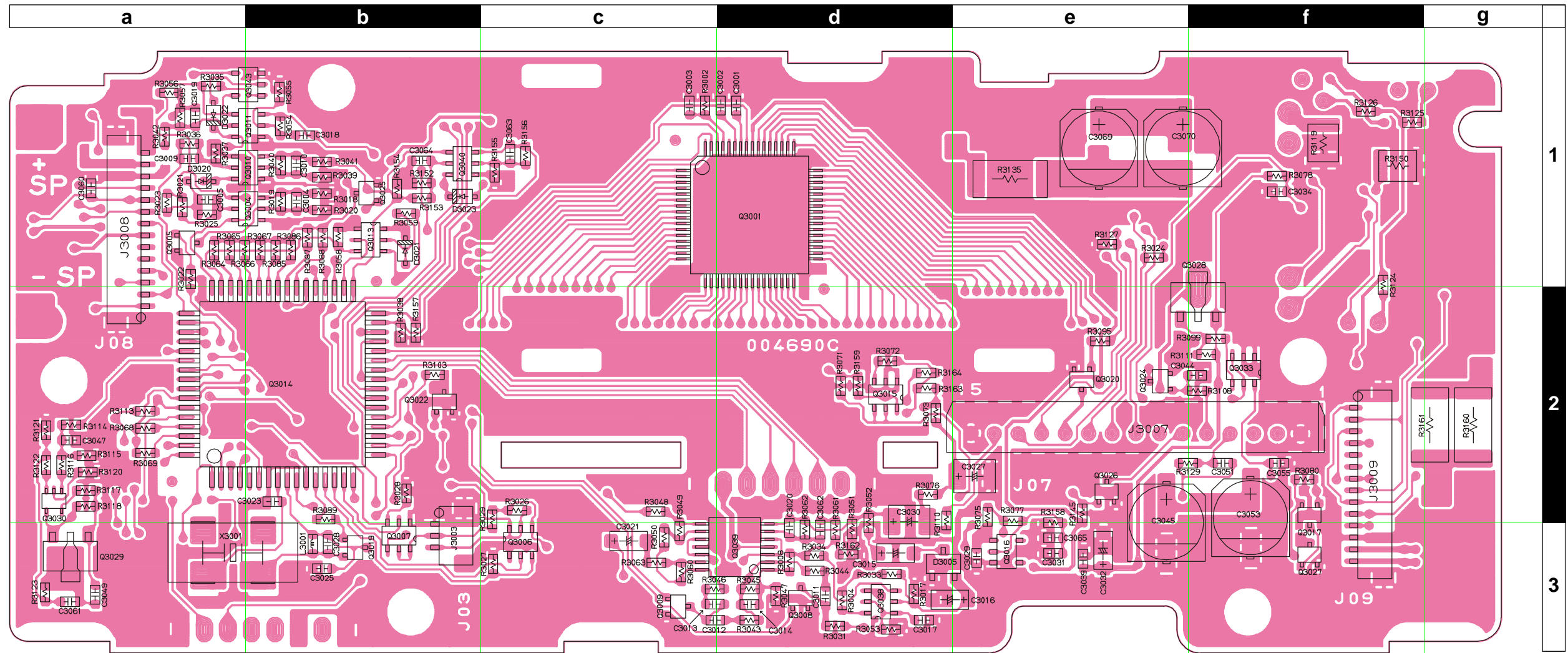

Side B

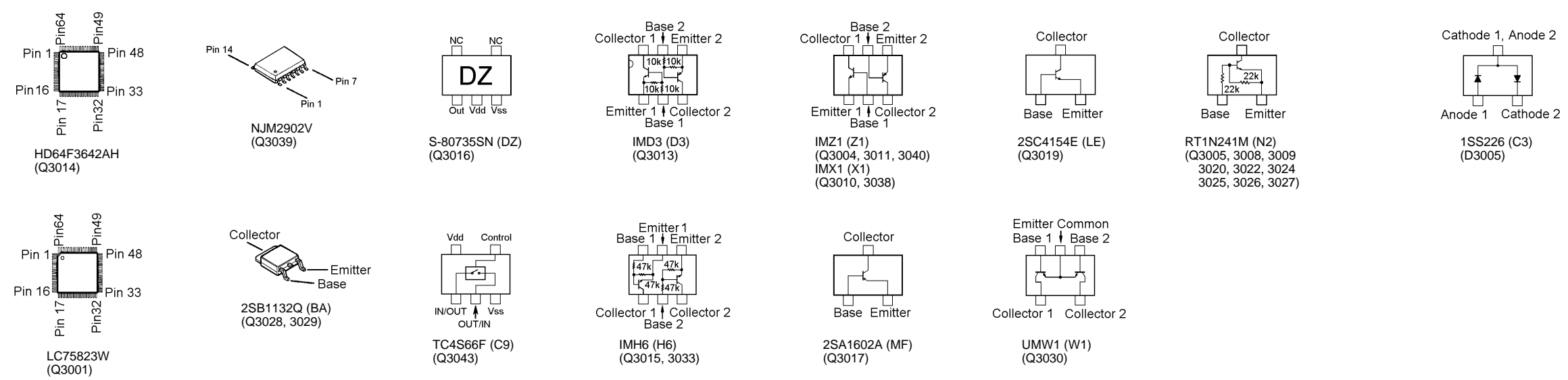

DISPLAY Unit (Lot. 3~)

Note:

Parts Layout

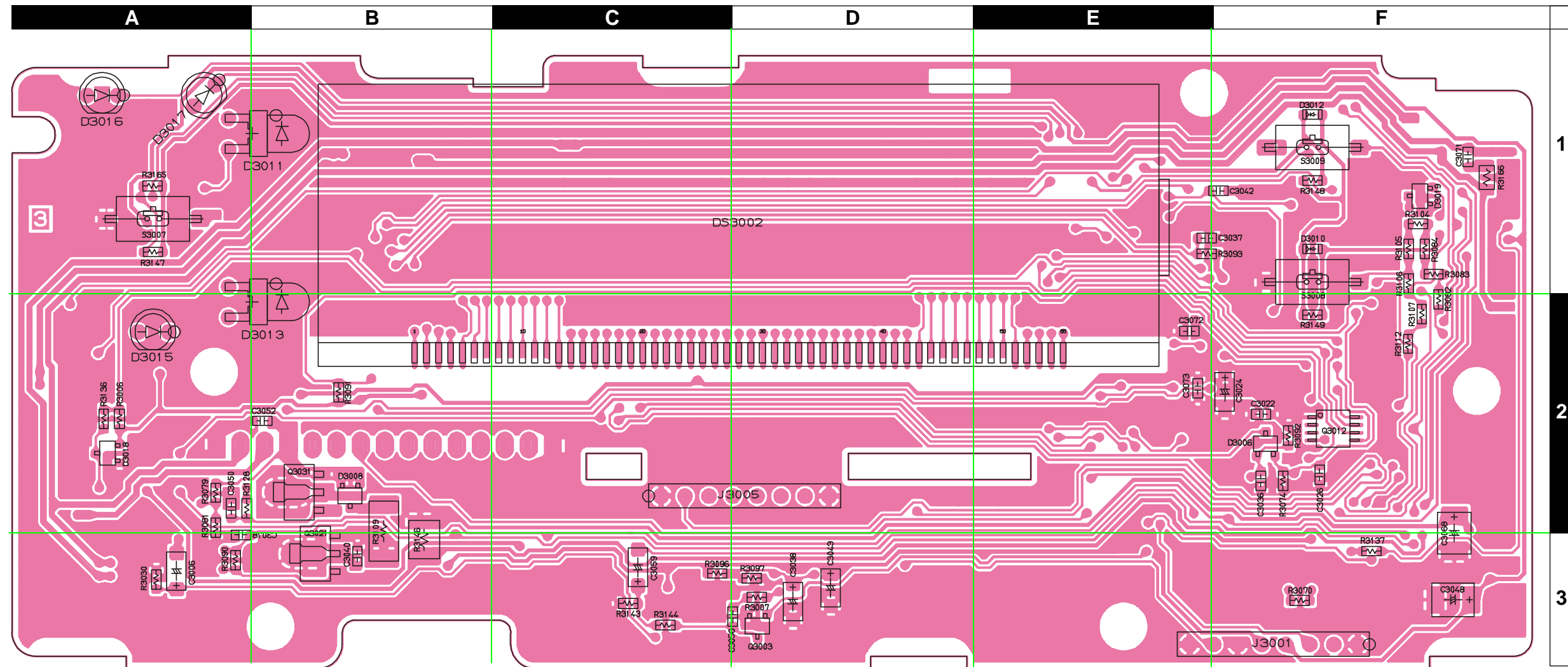

Side A

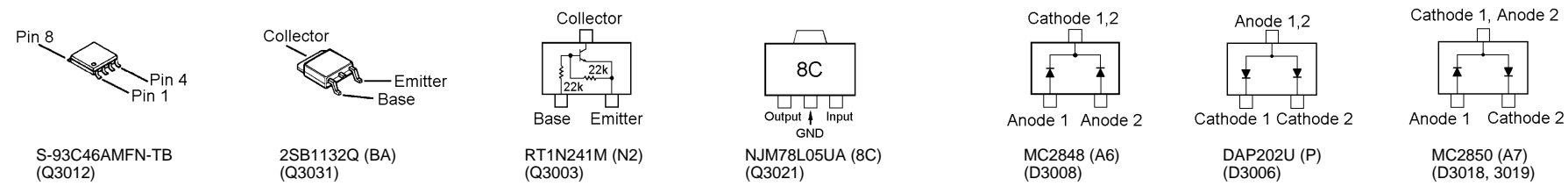

DISPLAY Unit (Lot. 3~)

Parts Layout

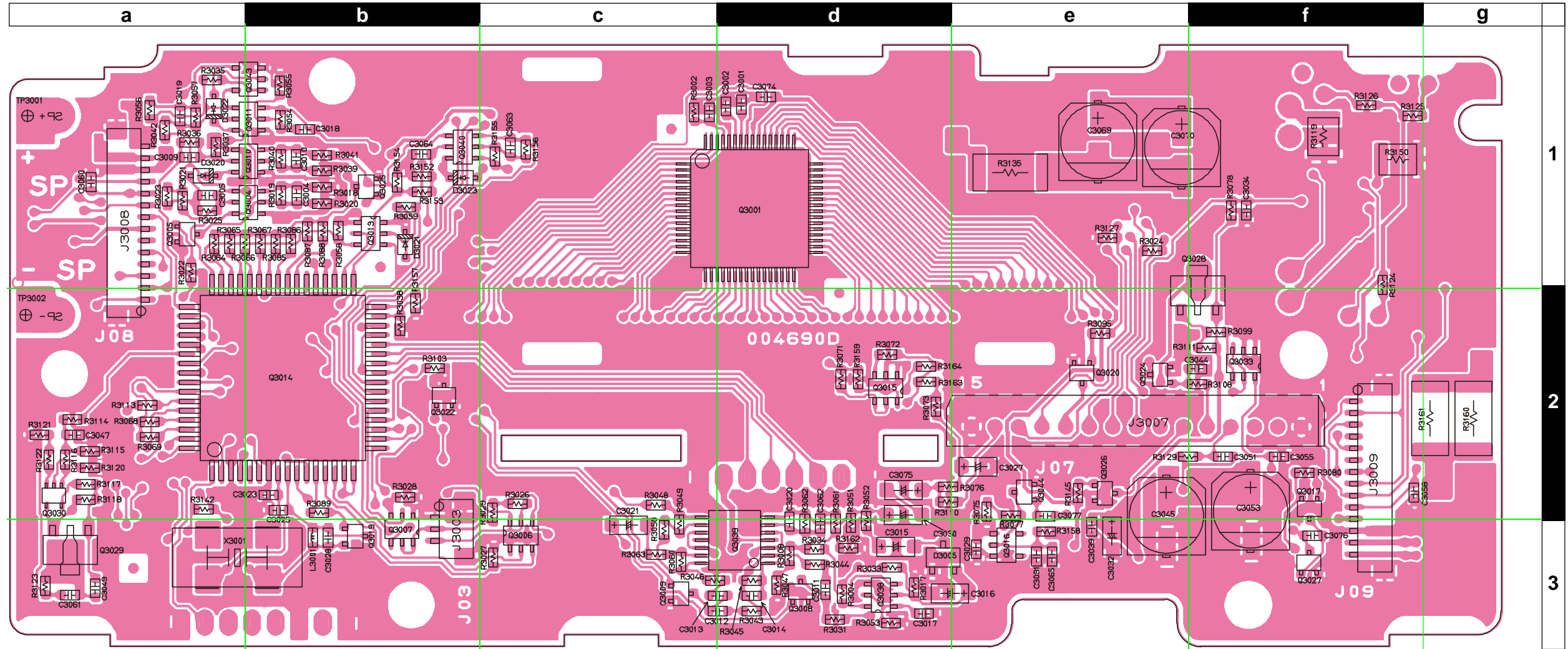

Side B

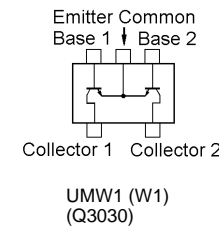
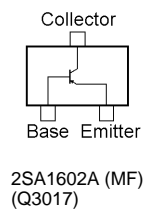
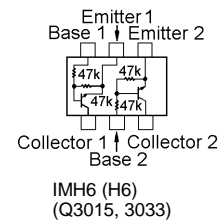
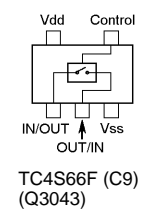
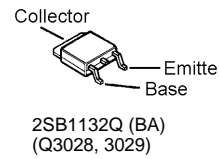
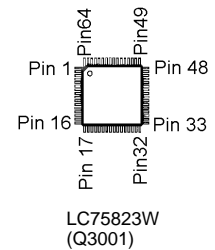
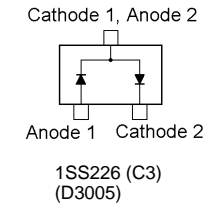
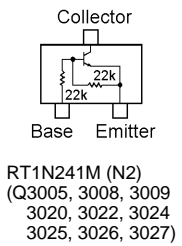
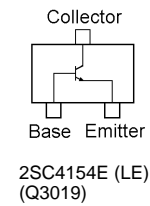
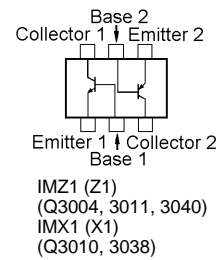
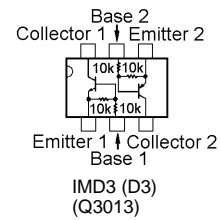
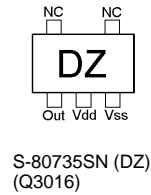
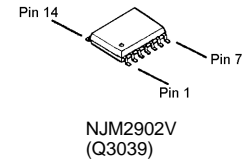
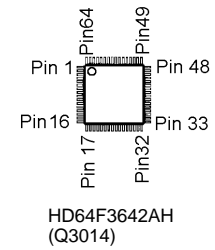

Parts List

REF.	DESCRIPTION	VALUE	WV	TOL.	MFR'S DESIG	VXSTD P/N	VERS.	LOT.	SIDE	LAY ADR.
*** DISPLAY UNIT ***										
PCB with Components						CB1088001				
Printed Circuit Board						FR004690C		1-		
Printed Circuit Board						FR004690D		3-		
C 3001	CHIP CAP.	0.1uF	16V	B	GRM39B104K16PT	K22124805		1-	B	d1
C 3002	CHIP CAP.	0.1uF	16V	B	GRM39B104K16PT	K22124805		1-	B	d1
C 3003	CHIP CAP.	680pF	50V	B	GRM39B681M50PT	K22174807		1-	B	c1
C 3004	CHIP CAP.	470pF	50V	B	GRM39B471M50PT	K22174805		1-	B	b1
C 3005	CHIP CAP.	470pF	50V	B	GRM39B471M50PT	K22174805		1-	B	a1
C 3006	CHIP TA.CAP.	4.7uF	16V		TEMSVB21C475M-8R	K78120016		1-	A	A3
C 3006	CHIP TA.CAP.	10uF	10V		TEMSVA1A106M-8R	K78100028		3-	A	A3
C 3009	CHIP CAP.	470pF	50V	B	GRM39B471M50PT	K22174805		1-	B	a1
C 3010	CHIP CAP.	470pF	50V	B	GRM39B471M50PT	K22174805		1-	B	b1
C 3011	CHIP CAP.	0.1uF	16V	B	GRM39B104K16PT	K22124805		1-	B	d3
C 3012	CHIP CAP.	0.1uF	16V	B	GRM39B104K16PT	K22124805		1-	B	d3
C 3013	CHIP CAP.	0.1uF	16V	B	GRM39B104K16PT	K22124805		1-	B	d3
C 3014	CHIP CAP.	22pF	50V	CH	GRM39CH220J50PT	K22174219		1-	B	d3
C 3015	CHIP TA.CAP.	2.2uF	6.3V		TESVA0J225M1-8R	K78080009		1-	B	d3
C 3016	CHIP TA.CAP.	33uF	4V		TEMSVA0G336M-8R	K78060036		1-	B	d3
C 3017	CHIP CAP.	0.1uF	16V	B	GRM39B104K16PT	K22124805		1-	B	d3
C 3018	CHIP CAP.	470pF	50V	B	GRM39B471M50PT	K22174805		1-	B	b1
C 3019	CHIP CAP.	470pF	50V	B	GRM39B471M50PT	K22174805		1-	B	a1
C 3020	CHIP CAP.	10pF	50V	CH	GRM39CH100D50PT	K22174211		1-	B	d3
C 3021	CHIP TA.CAP.	1uF	16V		TMCSA1C105MTR	K78120023		1-	B	c3
C 3022	CHIP CAP.	0.1uF	16V	B	GRM39B104K16PT	K22124805		1-	A	F2
C 3023	CHIP CAP.	4pF	50V	CH	GRM39CH040C50PT	K22174205		1-	B	b2
C 3024	CHIP TA.CAP.	4.7uF	16V		TEMSVB21C475M-8R	K78120016		1-	A	F2
C 3024	CHIP TA.CAP.	10uF	10V		TEMSVA1A106M-8R	K78100028		3-	A	F2
C 3025	CHIP CAP.	18pF	50V	CH	GRM39CH180J50PT	K22174217		1-	B	b2
C 3026	CHIP CAP.	0.1uF	16V	B	GRM39B104K16PT	K22124805		1-	A	F2
C 3027	CHIP TA.CAP.	4.7uF	16V		TEMSVB21C475M-8R	K78120016		1-	B	e2
C 3027	CHIP TA.CAP.	4.7uF	16V		TEMSVA1C475M-8R	K78120031		3-	B	e2
C 3028	CHIP CAP.	4pF	50V	CH	GRM39CH040C50PT	K22174205		1-	B	b3
C 3029	CHIP CAP.	0.01uF	25V	B	GRM39B103K25PT	K22144803		1-	B	e3
C 3030	TANTALUM CAP.	10uF	10V		DN1A100M1S	K70107106		1-	B	d2
C 3030	CHIP TA.CAP.	10uF	10V		TEMSVA1A106M-8R	K78100028		3-	B	d2
C 3031	CHIP CAP.	0.1uF	16V	B	GRM39B104K16PT	K22124805		1-	B	e3
C 3032	CHIP TA.CAP.	10uF	10V		TEMSVA1A106M-8R	K78100028		1-	B	e3
C 3034	CHIP CAP.	0.1uF	16V	B	GRM39B104K16PT	K22124805		1-	B	f1
C 3036	CHIP CAP.	0.1uF	16V	B	GRM39B104K16PT	K22124805		1-	A	F2
C 3037	CHIP CAP.	0.01uF	25V	B	GRM39B103K25PT	K22144803		1-	A	E1
C 3038	CHIP TA.CAP.	4.7uF	16V		TEMSVB21C475M-8R	K78120016		1-	A	D3
C 3038	CHIP TA.CAP.	10uF	10V		TEMSVA1A106M-8R	K78100028		3-	A	D3
C 3039	CHIP CAP.	0.001uF	50V	B	GRM39B102K50PT	K22174821		1-	B	e3
C 3040	CHIP CAP.	0.001uF	50V	B	GRM39B102K50PT	K22174821		1-	A	B3
C 3042	CHIP CAP.	0.1uF	16V	B	GRM39B104K16PT	K22124805		1-	A	F1
C 3043	CHIP TA.CAP.	10uF	10V		TEMSVA1A106M-8R	K78100028		1-	A	D3
C 3044	CHIP CAP.	0.1uF	16V	B	GRM39B104K16PT	K22124805		1-8	B	f2
C 3045	AL.ELECTRO.CAP.	100uF	16V		ECEV1CA101WP	K48120012		1-	B	e2
C 3047	CHIP CAP.	33pF	50V	CH	GRM39CH330J50PT	K22174223		1-	B	a2
C 3049	CHIP CAP.	33pF	50V	CH	GRM39CH330J50PT	K22174223		1-	B	a3
C 3050	CHIP CAP.	0.01uF	25V	B	GRM39B103K25PT	K22144803		1-	A	A2
C 3051	CHIP CAP.	0.1uF	16V	B	GRM39B104K16PT	K22124805		1-	B	f2
C 3053	AL.ELECTRO.CAP.	100uF	16V		ECEV1CA101WP	K48120012		1-	B	f2
C 3055	CHIP CAP.	0.01uF	25V	B	GRM39B103K25PT	K22144803		1-	B	f2
C 3056	CHIP CAP.	0.1uF	16V	B	GRM39B104K16PT	K22124805		1-	A	D3
C 3058	CHIP CAP.	0.01uF	25V	B	GRM39B103K25PT	K22144803		1-	B	f2
C 3059	CHIP TA.CAP.	4.7uF	16V		TEMSVB21C475M-8R	K78120016		1-	A	C3
C 3059	CHIP TA.CAP.	10uF	10V		TEMSVA1A106M-8R	K78100028		3-	A	C3
C 3060	CHIP CAP.	0.01uF	25V	B	GRM39B103K25PT	K22144803		1-	B	a1

DISPLAY Unit

REF.	DESCRIPTION	VALUE	WV	TOL.	MFR'S DESIG	VXSTD P/N	VERS.	LOT.	SIDE	LAY ADR.
C 3062	CHIP CAP.	0.1uF	16V	B	GRM39B104K16PT	K22124805		1-	B	d3
C 3063	CHIP CAP.	470pF	50V	B	GRM39B471M50PT	K22174805		1-	B	c1
C 3064	CHIP CAP.	470pF	50V	B	GRM39B471M50PT	K22174805		1-	B	b1
C 3065	CHIP CAP.	0.1uF	16V	B	GRM39B104K16PT	K22124805		1-	B	e3
C 3069	AL.ELECTRO.CAP.	100uF	16V		ECEV1CA101WP	K48120012		1-	B	e1
C 3070	AL.ELECTRO.CAP.	100uF	16V		ECEV1CA101WP	K48120012		1-	B	e1
C 3071	CERAMIC CAP.	0.022uF	50V	F	DD108F223Z50	K13179010		1-	A	G1
C 3071	CHIP CAP.	0.022uF	25V	B	GRM39B223K25PT	K22144807		3-	A	G1
C 3074	CHIP CAP.	0.1uF	16V	B	GRM39B104K16PT	K22124805		3-	B	d1
C 3075	TANTALUM CAP.	10uF	10V		DN1A100M1S	K70107106		1-	B	d2
C 3075	CHIP TA.CAP.	10uF	10V		TEMSVA1A106M-8R	K78100028		3-	B	d2
C 3076	CHIP CAP.	0.1uF	16V	B	GRM39B104K16PT	K22124805		3-	B	f3
C 3079	CHIP TA.CAP.	1uF	25V		TEMSVA1E105M-8R	K78140013		13-		
D 3005	DIODE				1SS226 TE85R	G2070003		1-	B	d3
D 3006	DIODE				DAP202U T106	G2070160		1-	A	F2
D 3008	DIODE				MC2848-T11-1	G2070694		1-	A	B2
D 3010	LED				TLOU1008(T4)	G2070796		1-	A	F1
D 3011	LED				TLOU262	G2090763		1-	A	A1
D 3012	LED				TLOU1008(T4)	G2070796		1-	A	F1
D 3013	LED				TLOU262	G2090763		1-	A	A2
D 3015	LED				GL3HS44	G2090675		1-	A	A2
D 3016	LED				GL3PR8	G2090433		1-	A	A1
D 3017	LED				GL3KG8	G2090432		1-	A	A1
D 3018	DIODE				MC2850-T11-1	G2070704		1-	A	A2
D 3019	DIODE				MC2850-T11-1	G2070704		1-	A	F1
D 3020	DIODE				BAS316	G2070716		1-	B	a1
D 3021	DIODE				BAS316	G2070716		1-	B	b1
D 3022	DIODE				BAS316	G2070716		1-	B	a1
D 3023	DIODE				BAS316	G2070716		1-	B	b1
DS3002	LCD				MS-6403	G6090140		1-	A	D1
J 3001	CONNECTOR				9210B-1-08Z696-T	P0091300		1-	A	F3
J 3005	CONNECTOR				9210B-1-08Z707-T	P0091304		1-	A	C2
J 3007	CONNECTOR				SB20-15WS	P0091093		1-	B	f2
J 3008	CONNECTOR				BM14B-SRSS-TBT	P0091302		1-	B	a1
J 3009	CONNECTOR				BM14B-SRSS-TBT	P0091302		1-	B	f2
JP3001	WIRE ASSY				GRN 20 2/2	T50502000		1-2		
JP3002	WIRE ASSY				GRN 50 2/2	T50505000		1-2		
L 3001	M.RFC	2.2uH			LK1608 2R2K-T	L1690634		1-	B	b3
Q 3001	IC				LC75823W	G1092941		1-	B	d1
Q 3003	TRANSISTOR				RT1N241M-T11-1	G3070249		1-	A	D3
Q 3004	TRANSISTOR				IMZ1 T108	G3070025		1-	B	b1
Q 3005	TRANSISTOR				RT1N241M-T11-1	G3070249		1-	B	a1
Q 3008	TRANSISTOR				RT1N241M-T11-1	G3070249		1-	B	d3
Q 3009	TRANSISTOR				RT1N241M-T11-1	G3070249		1-	B	c3
Q 3010	TRANSISTOR				IMX1 T110	G3070024		1-	B	b1
Q 3011	TRANSISTOR				IMZ1 T108	G3070025		1-	B	b1
Q 3012	IC				S-93C46AMFN-TB	G1093147		1-	A	F2
Q 3013	TRANSISTOR				IMD3 T108	G3070053		1-	B	b1
Q 3014	IC				HD64F3642AH R0508	G1093509		1-	B	b2
Q 3014	IC				HD64F3642AH R0527	G1093539		3-	B	b2
Q 3014	IC				HD64F3642AH(FLASH)	G1093228		9-	B	b2
Q 3015	TRANSISTOR				IMH6A T108	G3070066		1-	B	d2
Q 3016	IC				S-80735SN-DZ-T1	G1091876		1-	B	e3
Q 3016	IC				S-80835CNMC-B8U-T2	G1093606		13-	B	e3
Q 3017	TRANSISTOR				2SA1602A-T11-1F	G3116028F		1-	B	f2
Q 3019	TRANSISTOR				2SC4154-T11-1E	G3341548E		1-	B	b3
Q 3020	TRANSISTOR				RT1N241M-T11-1	G3070249		1-	B	e2
Q 3021	IC				NJM78L05UA TE1	G1091325		1-	A	B3
Q 3022	TRANSISTOR				RT1N241M-T11-1	G3070249		1-	B	b2
Q 3024	TRANSISTOR				RT1N241M-T11-1	G3070249		1-8	B	e2

× Requires Firmware, CE35 and FIF-8.

REF.	DESCRIPTION	VALUE	WV	TOL.	MFR'S DESIG	VXSTD P/N	VERS.	LOT.	SIDE	LAY ADR.
Q 3025	TRANSISTOR				RT1N241M-T11-1	G3070249		1-	B	b1
Q 3026	TRANSISTOR				RT1N241M-T11-1	G3070249		1-	B	e2
Q 3027	TRANSISTOR				RT1N241M-T11-1	G3070249		1-	B	f3
Q 3028	TRANSISTOR				2SB1132 T100 Q	G3211327Q		1-	B	f2
Q 3029	TRANSISTOR				2SB1132 T100 Q	G3211327Q		1-	B	a3
Q 3030	TRANSISTOR				UMW1 TR	G3070078		1-	B	a2
Q 3031	TRANSISTOR				2SB1132 T100 Q	G3211327Q		1-	A	B2
Q 3033	TRANSISTOR				IMH6A T108	G3070066		1-	B	f2
Q 3038	TRANSISTOR				IMX1 T110	G3070024		1-	B	d3
Q 3039	IC				NJM2902V-TE1	G1091679		1-	B	d3
Q 3040	TRANSISTOR				IMZ1 T108	G3070025		1-	B	b1
Q 3043	IC				TC4S66F TE85R	G1090893		1-	B	b1
R 3002	CHIP RES.	47k	1/16W	5%	RMC1/16 473JATP	J24185473		1-	B	c1
R 3004	CHIP RES.	2.2k	1/16W	5%	RMC1/16 222JATP	J24185222		1-	B	d3
R 3006	CHIP RES.	56k	1/16W	5%	RMC1/16 563JATP	J24185563		1-	A	A2
R 3007	CHIP RES.	15k	1/16W	5%	RMC1/16 153JATP	J24185153		1-	A	D3
R 3008	CHIP RES.	27k	1/16W	5%	RMC1/16 273JATP	J24185273		1-	B	d3
R 3017	CHIP RES.	100k	1/16W	5%	RMC1/16 104JATP	J24185104		1-	B	d3
R 3018	CHIP RES.	4.7k	1/16W	5%	RMC1/16 472JATP	J24185472		1-	B	b1
R 3019	CHIP RES.	4.7k	1/16W	5%	RMC1/16 472JATP	J24185472		1-	B	b1
R 3020	CHIP RES.	4.7k	1/16W	5%	RMC1/16 472JATP	J24185472		1-	B	b1
R 3021	CHIP RES.	4.7k	1/16W	5%	RMC1/16 472JATP	J24185472		1-	B	a1
R 3022	CHIP RES.	2.2k	1/16W	5%	RMC1/16 222JATP	J24185222		1-	B	a1
R 3023	CHIP RES.	4.7k	1/16W	5%	RMC1/16 472JATP	J24185472		1-	B	a1
R 3024	CHIP RES.	330	1/16W	5%	RMC1/16 331JATP	J24185331		1-	B	e1
R 3025	CHIP RES.	4.7k	1/16W	5%	RMC1/16 472JATP	J24185472		1-	B	a1
R 3026	CHIP RES.	10k	1/16W	5%	RMC1/16 103JATP	J24185103		1-	B	c2
R 3027	CHIP RES.	10k	1/16W	5%	RMC1/16 103JATP	J24185103		1-	B	c3
R 3030	CHIP RES.	680	1/16W	5%	RMC1/16 681JATP	J24185681		1-	A	A3
R 3031	CHIP RES.	22k	1/16W	5%	RMC1/16 223JATP	J24185223		1-	B	d3
R 3033	CHIP RES.	1.5M	1/16W	5%	RMC1/16 155JATP	J24185155		1-	B	d3
R 3034	CHIP RES.	220	1/16W	5%	RMC1/16 221JATP	J24185221		1-	B	d3
R 3035	CHIP RES.	4.7k	1/16W	5%	RMC1/16 472JATP	J24185472		1-	B	a1
R 3036	CHIP RES.	4.7k	1/16W	5%	RMC1/16 472JATP	J24185472		1-	B	a1
R 3037	CHIP RES.	4.7k	1/16W	5%	RMC1/16 472JATP	J24185472		1-	B	a1
R 3038	CHIP RES.	2.2k	1/16W	5%	RMC1/16 222JATP	J24185222		1-	B	b2
R 3039	CHIP RES.	4.7k	1/16W	5%	RMC1/16 472JATP	J24185472		1-	B	b1
R 3040	CHIP RES.	4.7k	1/16W	5%	RMC1/16 472JATP	J24185472		1-	B	b1
R 3041	CHIP RES.	4.7k	1/16W	5%	RMC1/16 472JATP	J24185472		1-	B	b1
R 3042	CHIP RES.	4.7k	1/16W	5%	RMC1/16 472JATP	J24185472		1-	B	a1
R 3043	CHIP RES.	15k	1/16W	5%	RMC1/16 153JATP	J24185153		1-	B	d3
R 3044	CHIP RES.	15k	1/16W	5%	RMC1/16 153JATP	J24185153		1-	B	d3
R 3045	CHIP RES.	330k	1/16W	5%	RMC1/16 334JATP	J24185334		1-	B	d3
R 3046	CHIP RES.	220k	1/16W	5%	RMC1/16 224JATP	J24185224		1-	B	c3
R 3047	CHIP RES.	2.2k	1/16W	5%	RMC1/16 222JATP	J24185222		1-	B	d3
R 3048	CHIP RES.	10k	1/16W	5%	RMC1/16 103JATP	J24185103		1-	B	c2
R 3049	CHIP RES.	2.2M	1/16W	5%	RMC1/16 225JATP	J24185225		1-	B	c3
R 3050	CHIP RES.	10k	1/16W	5%	RMC1/16 103JATP	J24185103		1-	B	c3
R 3051	CHIP RES.	1k	1/16W	5%	RMC1/16 102JATP	J24185102		1-	B	d3
R 3052	CHIP RES.	220	1/16W	5%	RMC1/16 221JATP	J24185221		1-	B	d3
R 3053	CHIP RES.	1.2M	1/16W	5%	RMC1/16 125JATP	J24185125		1-	B	d3
R 3054	CHIP RES.	4.7k	1/16W	5%	RMC1/16 472JATP	J24185472		1-	B	b1
R 3055	CHIP RES.	4.7k	1/16W	5%	RMC1/16 472JATP	J24185472		1-	B	b1
R 3056	CHIP RES.	4.7k	1/16W	5%	RMC1/16 472JATP	J24185472		1-	B	a1
R 3057	CHIP RES.	4.7k	1/16W	5%	RMC1/16 472JATP	J24185472		1-	B	a1
R 3058	CHIP RES.	10k	1/16W	5%	RMC1/16 103JATP	J24185103		1-	B	b1
R 3059	CHIP RES.	10k	1/16W	5%	RMC1/16 103JATP	J24185103		1-	B	b1
R 3060	CHIP RES.	330k	1/16W	5%	RMC1/16 334JATP	J24185334		1-	B	c3
R 3061	CHIP RES.	10k	1/16W	5%	RMC1/16 103JATP	J24185103		1-	B	d3
R 3062	CHIP RES.	1.2M	1/16W	5%	RMC1/16 125JATP	J24185125		1-	B	d3

DISPLAY Unit

REF.	DESCRIPTION	VALUE	WV	TOL.	MFR'S DESIG	VXSTD P/N	VERS.	LOT.	SIDE	LAY ADR.
R 3063	CHIP RES.	10k	1/16W	5%	RMC1/16 103JATP	J24185103		1-	B	c3
R 3064	CHIP RES.	1.2k	1/16W	5%	RMC1/16 122JATP	J24185122		1-	B	a1
R 3065	CHIP RES.	2.7k	1/16W	5%	RMC1/16 272JATP	J24185272		1-	B	a1
R 3066	CHIP RES.	5.6k	1/16W	5%	RMC1/16 562JATP	J24185562		1-	B	a1
R 3067	CHIP RES.	12k	1/16W	5%	RMC1/16 123JATP	J24185123		1-	B	b1
R 3068	CHIP RES.	10k	1/16W	5%	RMC1/16 103JATP	J24185103		1-	B	a2
R 3069	CHIP RES.	10k	1/16W	5%	RMC1/16 103JATP	J24185103		1-	B	a2
R 3070	CHIP RES.	1M	1/16W	5%	RMC1/16 105JATP	J24185105		1-	A	F3
R 3071	CHIP RES.	10k	1/16W	5%	RMC1/16 103JATP	J24185103		1-	B	d2
R 3072	CHIP RES.	10k	1/16W	5%	RMC1/16 103JATP	J24185103		1-	B	d2
R 3073	CHIP RES.	2.2k	1/16W	5%	RMC1/16 222JATP	J24185222		1-	B	d2
R 3074	CHIP RES.	47k	1/16W	5%	RMC1/16 473JATP	J24185473		1-	A	F2
R 3075	CHIP RES.	10k	1/16W	5%	RMC1/16 103JATP	J24185103		1-	B	e2
R 3076	CHIP RES.	47k	1/16W	5%	RMC1/16 473JATP	J24185473		1-	B	d2
R 3077	CHIP RES.	47k	1/16W	5%	RMC1/16 473JATP	J24185473		1-	B	e2
R 3078	CHIP RES.	47k	1/16W	5%	RMC1/16 473JATP	J24185473		1-	B	f1
R 3079	CHIP RES.	15k	1/16W	5%	RMC1/16 153JATP	J24185153		1-	A	A2
R 3080	CHIP RES.	220k	1/16W	5%	RMC1/16 224JATP	J24185224		1-	B	f2
R 3081	CHIP RES.	12k	1/16W	5%	RMC1/16 123JATP	J24185123		1-	A	A2
R 3082	CHIP RES.	330k	1/16W	5%	RMC1/16 334JATP	J24185334		1-	A	F2
R 3083	CHIP RES.	68k	1/16W	5%	RMC1/16 683JATP	J24185683		1-	A	F1
R 3084	CHIP RES.	33k	1/16W	5%	RMC1/16 333JATP	J24185333		1-	A	F1
R 3085	CHIP RES.	27k	1/16W	5%	RMC1/16 273JATP	J24185273		1-	B	b1
R 3086	CHIP RES.	56k	1/16W	5%	RMC1/16 563JATP	J24185563		1-	B	b1
R 3087	CHIP RES.	120k	1/16W	5%	RMC1/16 124JATP	J24185124		1-	B	b1
R 3088	CHIP RES.	220k	1/16W	5%	RMC1/16 224JATP	J24185224		1-	B	b1
R 3089	CHIP RES.	15k	1/16W	5%	RMC1/16 153JATP	J24185153		1-	B	b2
R 3090	CHIP RES.	47k	1/16W	5%	RMC1/16 473JATP	J24185473		1-	A	A3
R 3091	CHIP RES.	47k	1/16W	5%	RMC1/16 473JATP	J24185473		1-8	A	B2
R 3092	CHIP RES.	10k	1/16W	5%	RMC1/16 103JATP	J24185103		1-	A	F2
R 3093	CHIP RES.	10k	1/16W	5%	RMC1/16 103JATP	J24185103		1-	A	E1
R 3095	CHIP RES.	2.2k	1/16W	5%	RMC1/16 222JATP	J24185222		1-	B	e2
R 3096	CHIP RES.	12k	1/16W	5%	RMC1/16 123JATP	J24185123		1-	A	C3
R 3097	CHIP RES.	10k	1/16W	5%	RMC1/16 103JATP	J24185103		1-	A	D3
R 3099	CHIP RES.	1k	1/16W	5%	RMC1/16 102JATP	J24185102		1-	B	f2
R 3103	CHIP RES.	10k	1/16W	5%	RMC1/16 103JATP	J24185103		1-	B	b2
R 3104	CHIP RES.	15k	1/16W	5%	RMC1/16 153JATP	J24185153		1-	A	F1
R 3105	CHIP RES.	12k	1/16W	5%	RMC1/16 123JATP	J24185123		1-	A	F1
R 3106	CHIP RES.	6.8k	1/16W	5%	RMC1/16 682JATP	J24185682		1-	A	F1
R 3107	CHIP RES.	8.2k	1/16W	5%	RMC1/16 822JATP	J24185822		1-	A	F2
R 3108	CHIP RES.	10k	1/16W	5%	RMC1/16 103JATP	J24185103		1-	B	f2
R 3109	CHIP RES.	15	1/2W	5%	RMC1/2 150JCTP	J24275150		1-	A	B2
R 3110	CHIP RES.	560	1/16W	5%	RMC1/16 561JATP	J24185561		1-	B	d2
R 3111	CHIP RES.	47k	1/16W	5%	RMC1/16 473JATP	J24185473		1-	B	f2
R 3112	CHIP RES.	0	1/16W	5%	RMC1/16 000JATP	J24185000		1-	A	F2
R 3113	CHIP RES.	33k	1/16W	5%	RMC1/16 333JATP	J24185333		1-	B	a2
R 3114	CHIP RES.	4.7k	1/16W	5%	RMC1/16 472JATP	J24185472		1-	B	a2
R 3115	CHIP RES.	47k	1/16W	5%	RMC1/16 473JATP	J24185473		1-	B	a2
R 3116	CHIP RES.	2.2k	1/16W	5%	RMC1/16 222JATP	J24185222		1-	B	a2
R 3117	CHIP RES.	1k	1/16W	5%	RMC1/16 102JATP	J24185102		1-	B	a2
R 3118	CHIP RES.	6.8k	1/16W	5%	RMC1/16 682JATP	J24185682		1-	B	a2
R 3119	CHIP RES.	180	1/4W	5%	RMC1/4 181JATP	J24245181		1-	B	f1
R 3120	CHIP RES.	1k	1/16W	5%	RMC1/16 102JATP	J24185102		1-	B	a2
R 3121	CHIP RES.	6.8k	1/16W	5%	RMC1/16 682JATP	J24185682		1-	B	a2
R 3122	CHIP RES.	2.2k	1/16W	5%	RMC1/16 222JATP	J24185222		1-	B	a2
R 3123	CHIP RES.	4.7k	1/16W	5%	RMC1/16 472JATP	J24185472		1-	B	a3
R 3124	CHIP RES.	470	1/16W	5%	RMC1/16 471JATP	J24185471		1-	B	f2
R 3125	CHIP RES.	330	1/16W	5%	RMC1/16 331JATP	J24185331		1-	B	f1
R 3126	CHIP RES.	100	1/16W	5%	RMC1/16 101JATP	J24185101		1-	B	f1
R 3127	CHIP RES.	10k	1/16W	5%	RMC1/16 103JATP	J24185103		1-	B	e1

REF.	DESCRIPTION	VALUE	WV	TOL.	MFR'S DESIG	VXSTD P/N	VERS.	LOT.	SIDE	LAY ADR.
R 3128	CHIP RES.	1k	1/16W	5%	RMC1/16 102JATP	J24185102		1-	A	A2
R 3129	CHIP RES.	47k	1/16W	5%	RMC1/16 473JATP	J24185473		1-	B	e2
R 3135	CHIP RES.	8.2	1W	5%	RMC1 8R2JTE	J24305829		1-	B	e1
R 3136	CHIP RES.	330	1/16W	5%	RMC1/16 331JATP	J24185331		1-	A	A2
R 3137	CHIP RES.	330	1/16W	5%	RMC1/16 331JATP	J24185331		1-	A	F3
R 3142	CHIP RES.	56k	1/16W	5%	RMC1/16 563JATP	J24185563		1-	B	a2
R 3143	CHIP RES.	680	1/16W	5%	RMC1/16 681JATP	J24185681		1-	A	C3
R 3144	CHIP RES.	22k	1/16W	5%	RMC1/16 223JATP	J24185223		1-	A	C3
R 3145	CHIP RES.	47k	1/16W	5%	RMC1/16 473JATP	J24185473		1-	B	e2
R 3146	CHIP RES.	220	1/4W	5%	RMC1/4 221JATP	J24245221		1-	A	B3
R 3147	CHIP RES.	0	1/16W	5%	RMC1/16 000JATP	J24185000		1-	A	A1
R 3150	CHIP RES.	470	1/4W	5%	RMC1/4 471JATP	J24245471		1-	B	f1
R 3152	CHIP RES.	4.7k	1/16W	5%	RMC1/16 472JATP	J24185472		1-	B	b1
R 3153	CHIP RES.	4.7k	1/16W	5%	RMC1/16 472JATP	J24185472		1-	B	b1
R 3154	CHIP RES.	4.7k	1/16W	5%	RMC1/16 472JATP	J24185472		1-	B	b1
R 3155	CHIP RES.	4.7k	1/16W	5%	RMC1/16 472JATP	J24185472		1-	B	c1
R 3156	CHIP RES.	4.7k	1/16W	5%	RMC1/16 472JATP	J24185472		1-	B	c1
R 3157	CHIP RES.	2.2k	1/16W	5%	RMC1/16 222JATP	J24185222		1-	B	b2
R 3158	CHIP RES.	180k	1/16W	5%	RMC1/16 184JATP	J24185184		1-	B	e3
R 3159	CHIP RES.	10k	1/16W	5%	RMC1/16 103JATP	J24185103		1-	B	d2
R 3160	CHIP RES.	4.7	1W	5%	RMC1 4R7JTE	J24305479		1-	B	g2
R 3161	CHIP RES.	4.7	1W	5%	RMC1 4R7JTE	J24305479		1-	B	g2
R 3162	CHIP RES.	2.7k	1/16W	5%	RMC1/16 272JATP	J24185272		1-	B	d3
R 3164	CHIP RES.	0	1/16W	5%	RMC1/16 000JATP	J24185000		1-	B	d2
R 3166	CHIP RES.	1	1/10W	5%	RMC1/10T 1R0J	J24205010		3-	A	G1
R 3167	CARBON FILM RES.	10k	1/6W	5%	RD16PJ103 10K	J01225103		1-		
R 3168	CHIP RES.	8.2k	1/16W	5%	RMC1/16 822JATP	J24185822		9-		
S 3007	TACT SWITCH				SKQDAB	N5090058		1-	A	A1
S 3008	TACT SWITCH				SKQDAB	N5090058		1-	A	F1
S 3009	TACT SWITCH				SKQDAB	N5090058		1-	A	F1
X 3001	XTAL 92SMX(A)	16MHz			16.000MHZ	H0103252		1-	B	a3
	LIGHT GUIDE					RA0252300		1-		
	REFLECTOR SHEET					RA0252700		1-		
	DIFFUSER SHEET					RA0252800		1-		
	RUBBER CONNECTOR					RA0252900		1-		
	LCD HOLDER					RA0253000		1-		
	LED SPACER				LH-5-6	S6000239		1-		
	LIGHT SHEET					RA0276500		5-		

DISPLAY Unit

Note:

Circuit Diagram

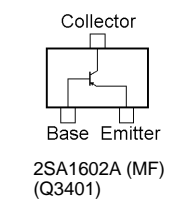
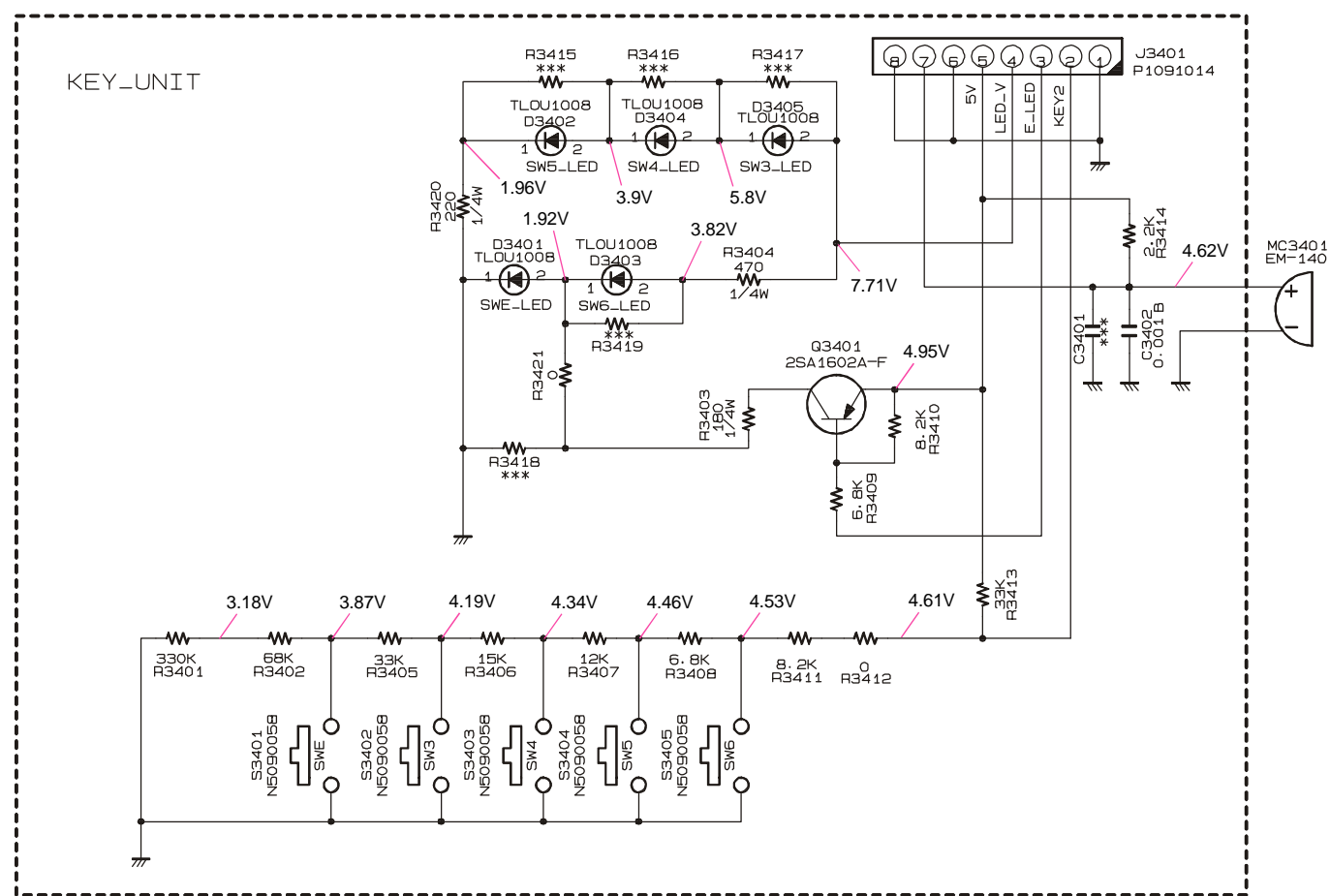

Parts Layout

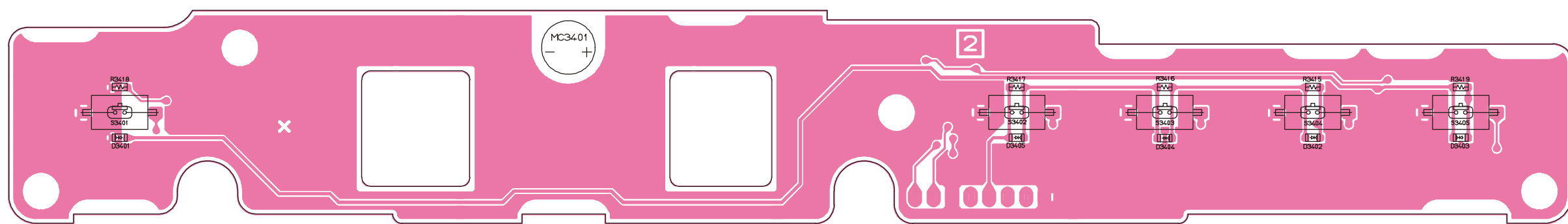

Side A

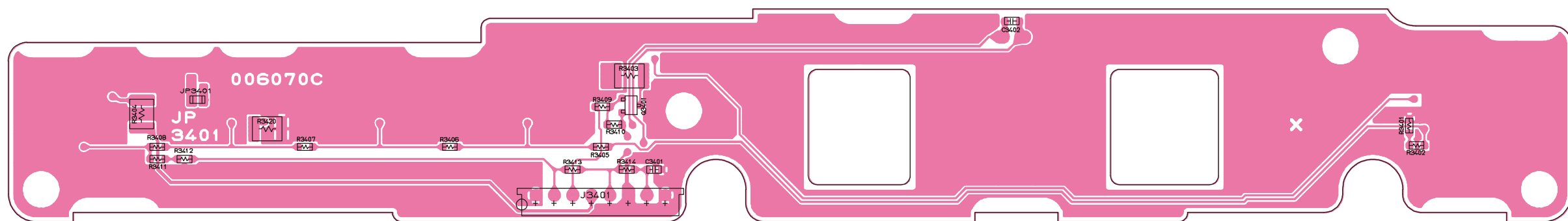

Side B

KEY Unit (Lot. 1~)

Note:

Circuit Diagram

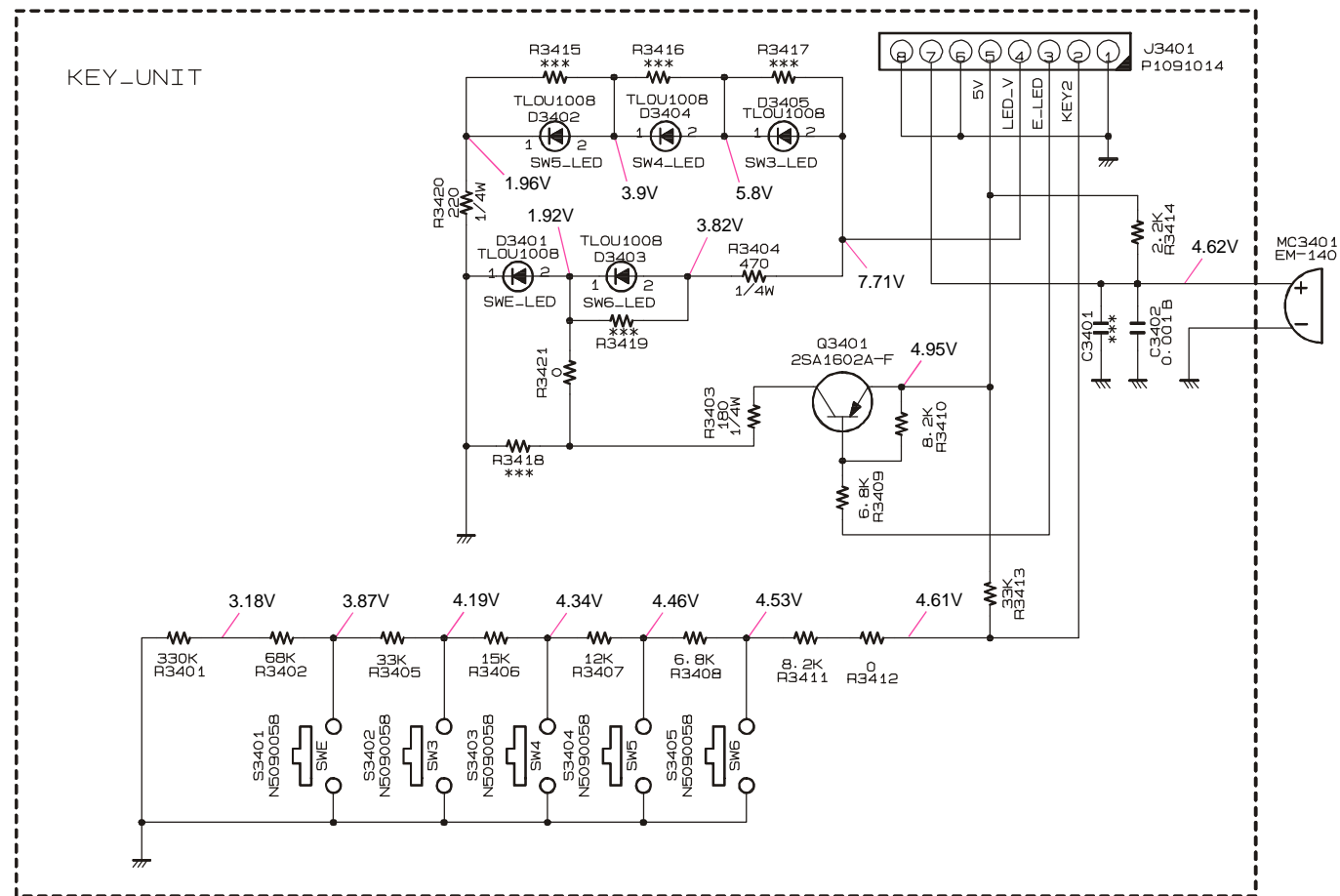

Parts Layout

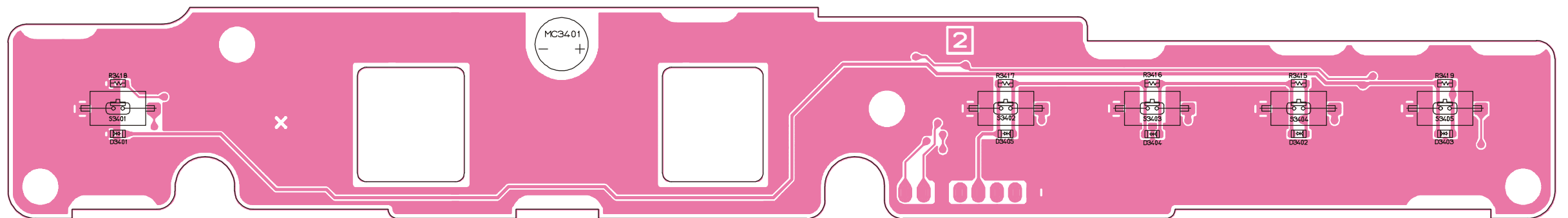

Side A

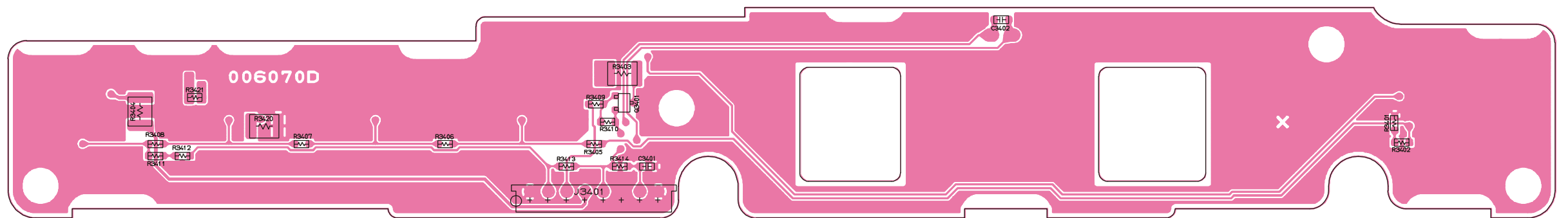

Side B

KEY Unit (Lot. 3~)

Note:

Parts List

REF.	DESCRIPTION	VALUE	WV	TOL.	MFR'S DESIG	VXSTD P/N	VERS.	LOT.	SIDE	LAY ADR.
*** KEY UNIT ***										
PCB with Components						CB1349001				
Printed Circuit Board						FR006070C		1-		
Printed Circuit Board						FR006070D		3-		
C 3402	CHIP CAP.	0.001uF	50V	B	GRM39B102K50PT	K22174821		1-	B	
D 3401	LED				TLOU1008(T4)	G2070796		1-	A	
D 3402	LED				TLOU1008(T4)	G2070796		1-	A	
D 3403	LED				TLOU1008(T4)	G2070796		1-	A	
D 3404	LED				TLOU1008(T4)	G2070796		1-	A	
D 3405	LED				TLOU1008(T4)	G2070796		1-	A	
J 3401	CONNECTOR				9110S-08	P1091014		1-	B	
MC3401	MIC. ELEMENT				EM-140	M3290032		1-	A	
Q 3401	TRANSISTOR				2SA1602A-T11-1F	G3116028F		1-	B	
R 3401	CHIP RES.	330k	1/16W	5%	RMC1/16 334JATP	J24185334		1-	B	
R 3402	CHIP RES.	68k	1/16W	5%	RMC1/16 683JATP	J24185683		1-	B	
R 3403	CHIP RES.	180	1/4W	5%	RMC1/4 181JATP	J24245181		1-	B	
R 3404	CHIP RES.	470	1/4W	5%	RMC1/4 471JATP	J24245471		1-	B	
R 3405	CHIP RES.	33k	1/16W	5%	RMC1/16 333JATP	J24185333		1-	B	
R 3406	CHIP RES.	15k	1/16W	5%	RMC1/16 153JATP	J24185153		1-	B	
R 3407	CHIP RES.	12k	1/16W	5%	RMC1/16 123JATP	J24185123		1-	B	
R 3408	CHIP RES.	6.8k	1/16W	5%	RMC1/16 682JATP	J24185682		1-	B	
R 3409	CHIP RES.	6.8k	1/16W	5%	RMC1/16 682JATP	J24185682		1-	B	
R 3410	CHIP RES.	8.2k	1/16W	5%	RMC1/16 822JATP	J24185822		1-	B	
R 3411	CHIP RES.	8.2k	1/16W	5%	RMC1/16 822JATP	J24185822		1-	B	
R 3412	CHIP RES.	0	1/16W	5%	RMC1/16 000JATP	J24185000		1-	B	
R 3413	CHIP RES.	33k	1/16W	5%	RMC1/16 333JATP	J24185333		1-	B	
R 3414	CHIP RES.	2.2k	1/16W	5%	RMC1/16 222JATP	J24185222		1-	B	
R 3420	CHIP RES.	220	1/4W	5%	RMC1/4 221JATP	J24245221		1-	B	
R 3421	CHIP RES.	0	1/16W	5%	RMC1/16 000JATP	J24185000		3-	B	
S 3401	TACT SWITCH				SKQDAB	N5090058		1-	A	
S 3402	TACT SWITCH				SKQDAB	N5090058		1-	A	
S 3403	TACT SWITCH				SKQDAB	N5090058		1-	A	
S 3404	TACT SWITCH				SKQDAB	N5090058		1-	A	
S 3405	TACT SWITCH				SKQDAB	N5090058		1-	A	

KEY Unit

Note:

Circuit Diagram

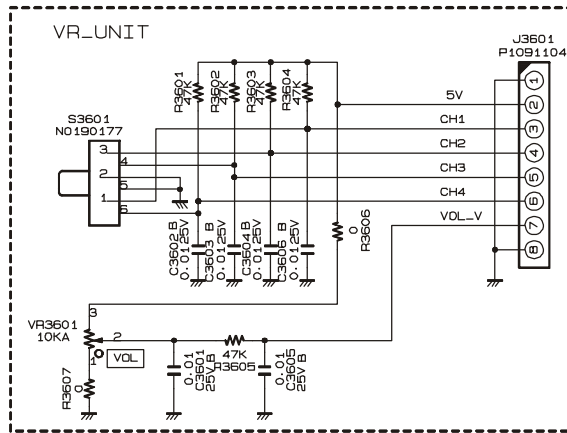

Parts Layout

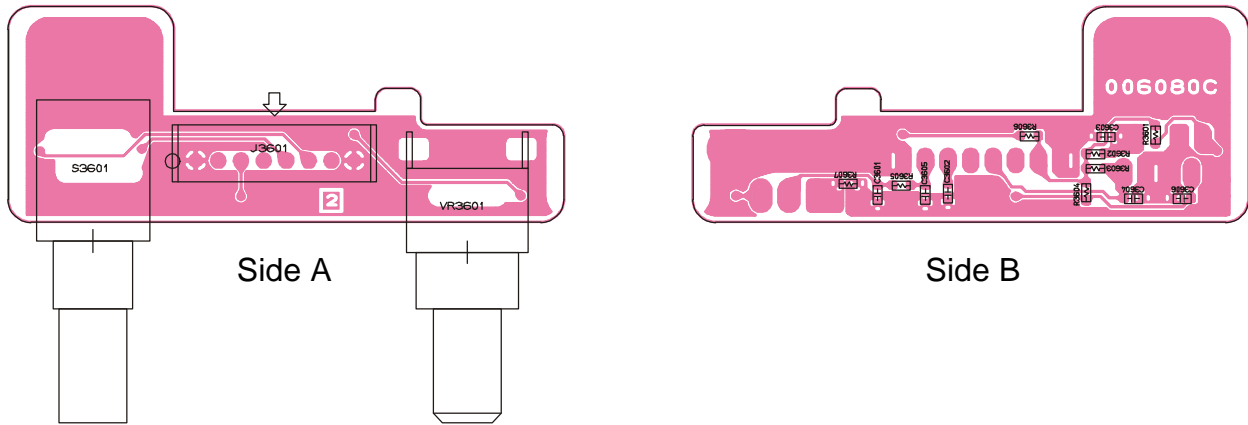

Parts List

REF.	DESCRIPTION	VALUE	WV	TOL.	MFR'S DESIG	VXSTD P/N	VERS.	LOT.	SIDE	LAY ADR.
*** VR UNIT ***										
PCB with Components						CB1350001				
Printed Circuit Board						FR006080C		1-		
C 3601	CHIP CAP.	0.01uF	25V	B	GRM39B103K25PT	K22144803		1-	B	
C 3602	CHIP CAP.	0.01uF	25V	B	GRM39B103K25PT	K22144803		1-	B	
C 3603	CHIP CAP.	0.01uF	25V	B	GRM39B103K25PT	K22144803		1-	B	
C 3604	CHIP CAP.	0.01uF	25V	B	GRM39B103K25PT	K22144803		1-	B	
C 3605	CHIP CAP.	0.01uF	25V	B	GRM39B103K25PT	K22144803		1-	B	
C 3606	CHIP CAP.	0.01uF	25V	B	GRM39B103K25PT	K22144803		1-	B	
J 3601	CONNECTOR				9110S-08L	P1091104		1-	A	
R 3601	CHIP RES.	47k	1/16W	5%	RMC1/16 473JATP	J24185473		1-	B	
R 3602	CHIP RES.	47k	1/16W	5%	RMC1/16 473JATP	J24185473		1-	B	
R 3603	CHIP RES.	47k	1/16W	5%	RMC1/16 473JATP	J24185473		1-	B	
R 3604	CHIP RES.	47k	1/16W	5%	RMC1/16 473JATP	J24185473		1-	B	
R 3605	CHIP RES.	47k	1/16W	5%	RMC1/16 473JATP	J24185473		1-	B	
R 3606	CHIP RES.	0	1/16W	5%	RMC1/16 000JATP	J24185000		1-	B	
R 3607	CHIP RES.	0	1/16W	5%	RMC1/16 000JATP	J24185000		1-	B	
S 3601	ROTARY SWITCH				SRZW0L	N0190177		1-	A	
VR3601	POT.				RK09L1120 L=15 10KC	J60800253		1-	A	
VR3601	POT.				RK09L1120 L=15 10KC	J60800258		5-	A	

MIC CONN Unit

Circuit Diagram

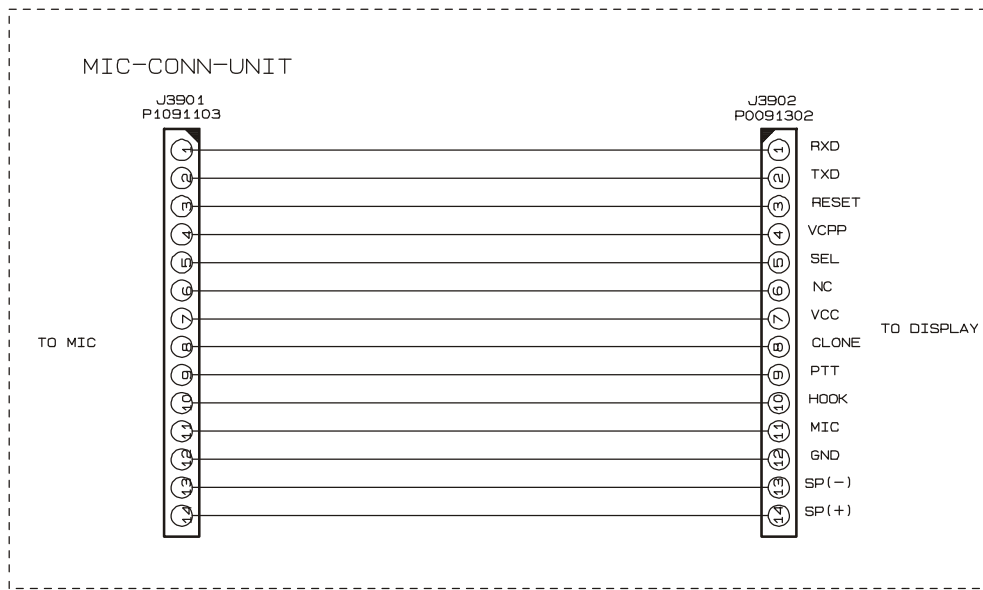

Parts Layout

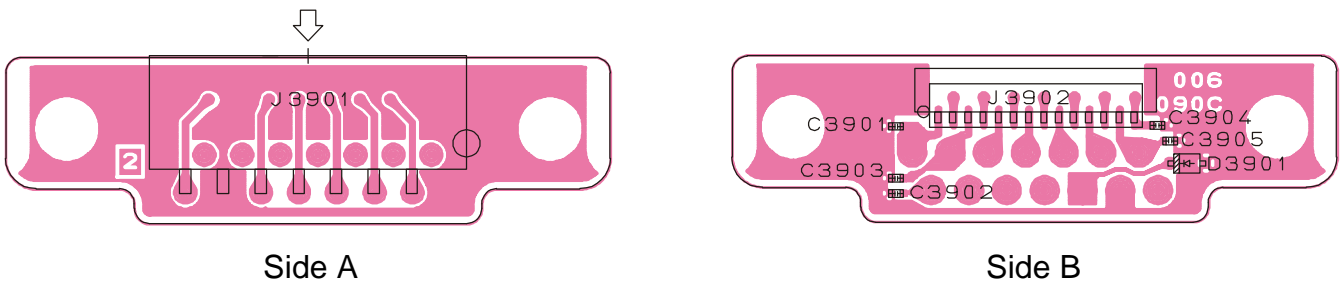

Parts List

REF.	DESCRIPTION	VALUE	WV	TOL.	MFR'S DESIG	VXSTD P/N	VERS.	LOT.	SIDE	LAY ADR.
*** MIC CONN UNIT ***										
PCB with Components						CB1384001				
Printed Circuit Board						FR006090C		1-		
J 3901	CONNECTOR				14FE-ST-VK-N	P1091103		1-	A	
J 3902	CONNECTOR				BM14B-SRSS-TBT	P0091302		1-	B	

F2D-8 2-Tone Decode Unit

Circuit Diagram

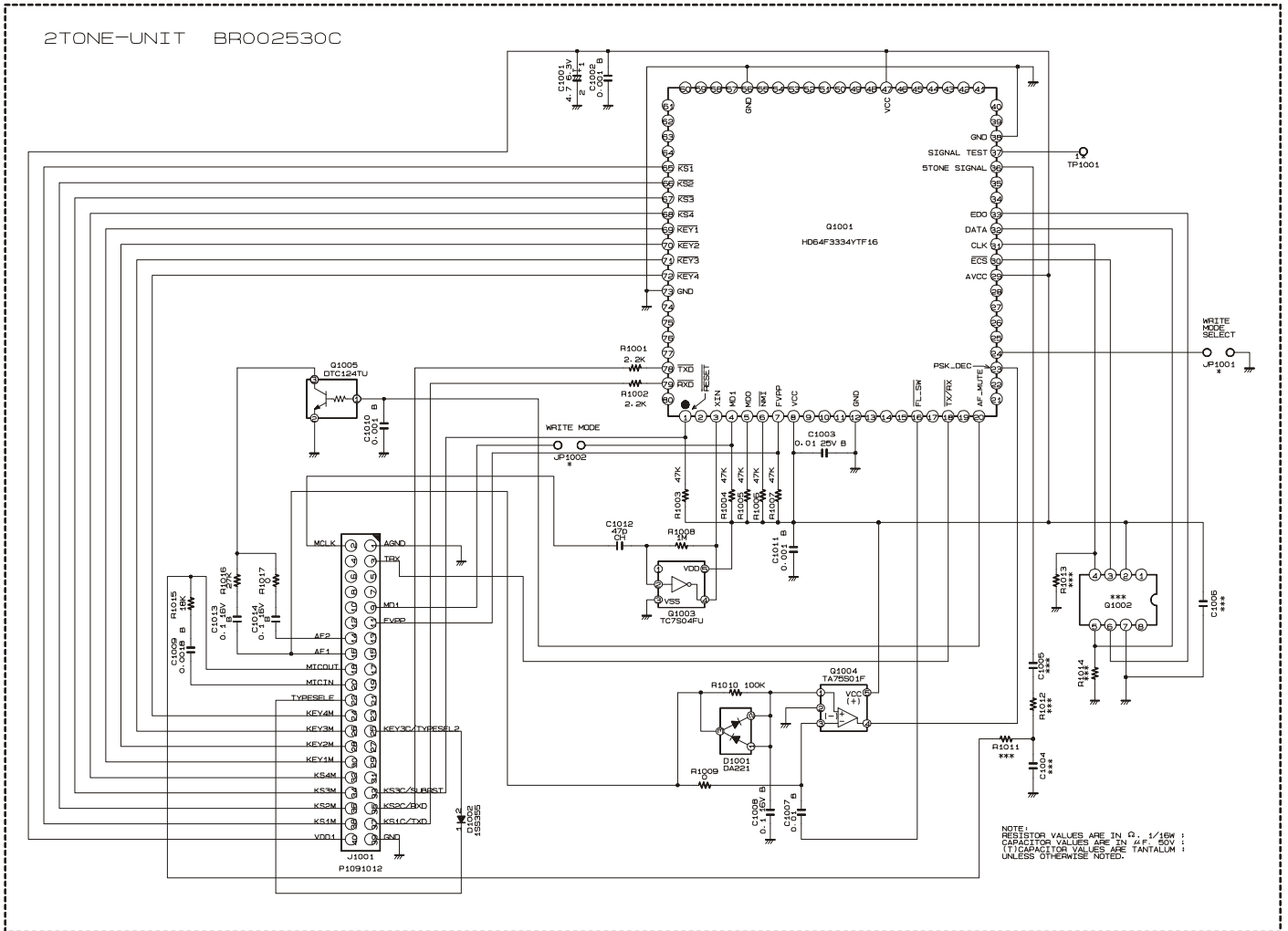

Parts Layout

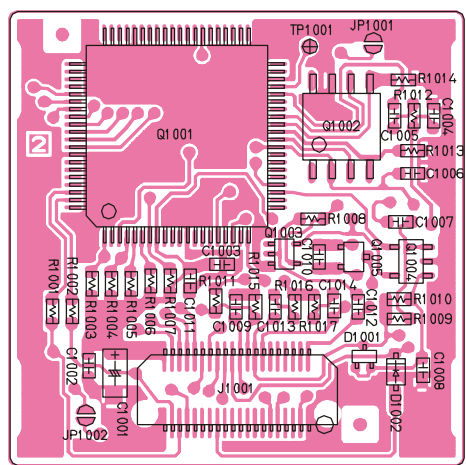

Side A

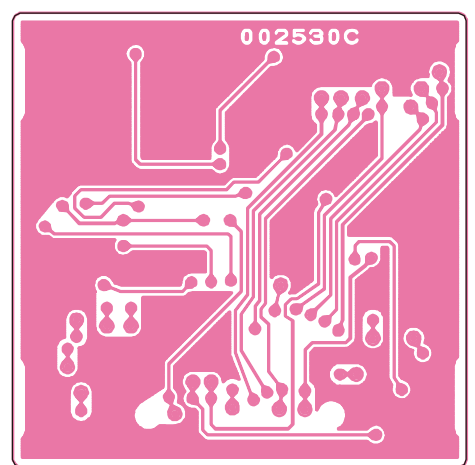

Side B

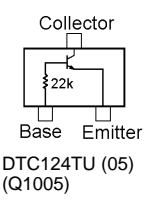
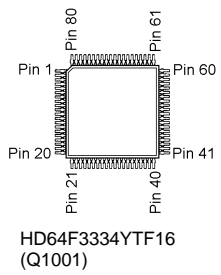
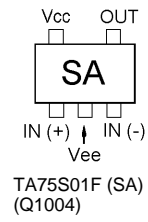
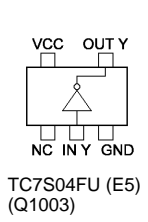

F2D-8 2-Tone Decode Unit

Parts List

REF.	DESCRIPTION	VALUE	V/W	TOL.	MFR'S DESIG	VXSTD P/N	VERS.	LOT.	SIDE	LAY ADR
*** F2D-8 ***										
Printed Circuit Board						FR002530C		1-		
C 1001	CHIP TA.CAP.	4.7uF	6.3V		TEMSVA0J475M-8R	K78080017		1-	A	
C 1002	CHIP CAP.	0.001uF	50V	B	GRM39B102K50PT	K22174821		1-	A	
C 1003	CHIP CAP.	0.01uF	25V	B	GRM39B103K25PT	K22144803		1-	A	
C 1007	CHIP CAP.	0.1uF	16V	B	GRM39B104K16PT	K22124805		1-	A	
C 1007	CHIP CAP.	0.0015uF	50V	B	GRM39B152M50PT	K22174811		6-	A	
C 1007	CHIP CAP.	0.01uF	50V	B	GRM39B103M50PT	K22174823		18-	A	
C 1008	CHIP CAP.	0.1uF	16V	B	GRM39B104K16PT	K22124805		1-	A	
C 1009	CHIP CAP.	0.0018uF	50V	B	GRM39B182M50PT	K22174812		1-	A	
C 1010	CHIP CAP.	0.001uF	50V	B	GRM39B102K50PT	K22174821		1-	A	
C 1011	CHIP CAP.	0.001uF	50V	B	GRM39B102K50PT	K22174821		1-	A	
C 1012	CHIP CAP.	47pF	50V	CH	GRM39CH470J50PT	K22174227		1-	A	
C 1013	CHIP CAP.	0.1uF	16V	B	GRM39B104K16PT	K22124805		1-	A	
C 1014	CHIP CAP.	0.1uF	16V	B	GRM39B104K16PT	K22124805		1-	A	
D 1001	DIODE				DA221 TL	G2070178		1-	A	
D 1002	DIODE				1SS355 TE-17	G2070470		1-	A	
J 1001	CONNECTOR				AXK5S40035P	P1091012		1-	A	
Q 1001	IC				HD64F3334YTF16 R0226	G1092873		1-	A	
Q 1003	IC				TC7S04FU TE85R	G1091530		1-	A	
Q 1004	IC				TA75S01F TE85R	G1091593		1-	A	
Q 1005	TRANSISTOR				DTC124TU T106	G3070065		1-	A	
R 1001	CHIP RES.	2.2k	1/16W	5%	RMC1/16 222JATP	J24185222		1-	A	
R 1002	CHIP RES.	2.2k	1/16W	5%	RMC1/16 222JATP	J24185222		1-	A	
R 1003	CHIP RES.	47k	1/16W	5%	RMC1/16 473JATP	J24185473		1-	A	
R 1004	CHIP RES.	47k	1/16W	5%	RMC1/16 473JATP	J24185473		1-	A	
R 1005	CHIP RES.	47k	1/16W	5%	RMC1/16 473JATP	J24185473		1-	A	
R 1006	CHIP RES.	47k	1/16W	5%	RMC1/16 473JATP	J24185473		1-	A	
R 1007	CHIP RES.	47k	1/16W	5%	RMC1/16 473JATP	J24185473		1-	A	
R 1008	CHIP RES.	1M	1/16W	5%	RMC1/16 105JATP	J24185105		1-	A	
R 1009	CHIP RES.	4.7k	1/16W	5%	RMC1/16 472JATP	J24185472		1-	A	
R 1009	CHIP RES.	0	1/16W	5%	RMC1/16 000JATP	J24185000		6-	A	
R 1010	CHIP RES.	100k	1/16W	5%	RMC1/16 104JATP	J24185104		1-	A	
R 1015	CHIP RES.	18k	1/16W	5%	RMC1/16 183JATP	J24185183		1-	A	
R 1016	CHIP RES.	0	1/16W	5%	RMC1/16 000JATP	J24185000		1-	A	
R 1016	CHIP RES.	27k	1/16W	5%	RMC1/16 273JATP	J24185273		6-	A	
R 1017	CHIP RES.	0	1/16W	5%	RMC1/16 000JATP	J24185000		1-	A	
	BLIND SHEET					RA0109300		1-		

F5D-14 5-Tone Unit

Circuit Diagram

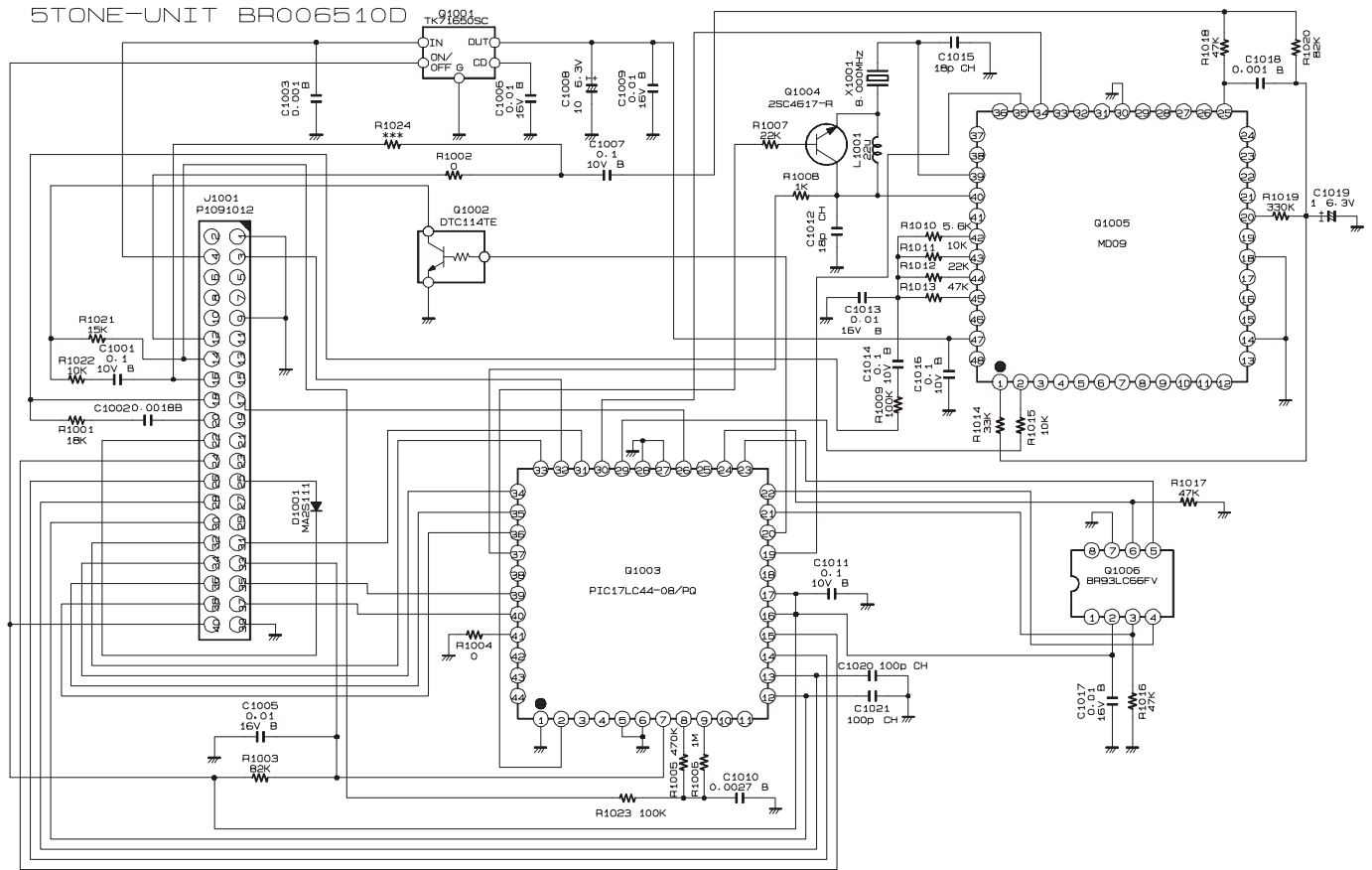

Parts Layout

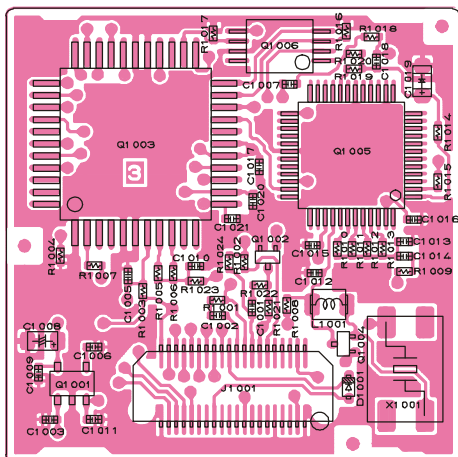

Side A

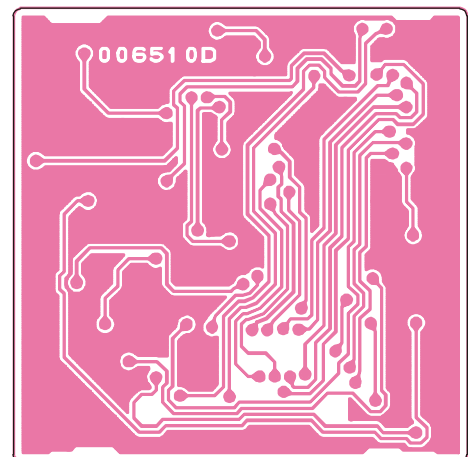

Side B

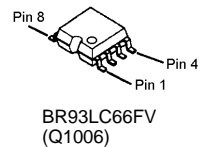
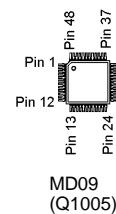
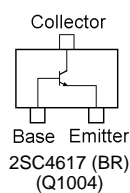
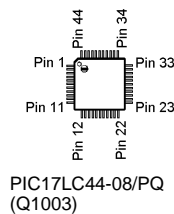
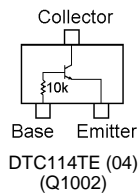
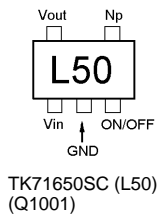

F5D-14 5-Tone Unit

Parts List

REF.	DESCRIPTION	VALUE	V/W	TOL.	MFR'S DESIG	VXSTD P/N	VERS.	LOT.	SIDE	LAY ADR
*** F5D-14 ***										
Printed Circuit Board						FR006510B		1-		
Printed Circuit Board						FR006510D		3-		
C 1001	CHIP CAP.	0.1uF	10V	B	GRM36B104K10PT	K22108802		1-	A	
C 1002	CHIP CAP.	0.0018uF	50V	B	GRM36B182K50PT	K22178812		1-	A	
C 1003	CHIP CAP.	0.001uF	50V	B	GRM36B102K50PT	K22178809		1-	A	
C 1005	CHIP CAP.	0.01uF	16V	B	GRM36B103K16PT	K22128804		1-	A	
C 1006	CHIP CAP.	0.01uF	16V	B	GRM36B103K16PT	K22128804		1-	A	
C 1007	CHIP CAP.	0.1uF	10V	B	GRM36B104K10PT	K22108802		1-	A	
C 1008	CHIP TA.CAP.	10uF	6.3V		EEJK0JS106R	K78080079		1-	A	
C 1008	CHIP TA.CAP.	10uF	6.3V		ECST0JZ106R	K78080078		8-	A	
C 1009	CHIP CAP.	0.01uF	16V	B	GRM36B103K16PT	K22128804		1-	A	
C 1010	CHIP CAP.	0.0027uF	50V	B	GRM36B272K50PT	K22178814		1-	A	
C 1011	CHIP CAP.	0.1uF	10V	B	GRM36B104K10PT	K22108802		1-	A	
C 1012	CHIP CAP.	18pF	50V	CH	GRM36CH180J50PT	K22178218		1-	A	
C 1013	CHIP CAP.	0.01uF	16V	B	GRM36B103K16PT	K22128804		1-	A	
C 1014	CHIP CAP.	0.1uF	10V	B	GRM36B104K10PT	K22108802		1-	A	
C 1015	CHIP CAP.	18pF	50V	CH	GRM36CH180J50PT	K22178218		1-	A	
C 1016	CHIP CAP.	0.1uF	10V	B	GRM36B104K10PT	K22108802		1-	A	
C 1017	CHIP CAP.	0.01uF	16V	B	GRM36B103K16PT	K22128804		1-	A	
C 1018	CHIP CAP.	0.001uF	50V	B	GRM36B102K50PT	K22178809		1-	A	
C 1019	CHIP TA.CAP.	1uF	6.3V		TMCP0J105MTR	K78080071		1-	A	
C 1020	CHIP CAP.	100pF	50V	CH	GRM36CH101J50PT	K22178236		1-	A	
C 1021	CHIP CAP.	100pF	50V	CH	GRM36CH101J50PT	K22178236		1-	A	
D 1001	DIODE				MA2S111-(TX)	G2070614		1-	A	
J 1001	CONNECTOR				AXK5S40035P	P1091012		1-	A	
L 1001	M.RFC	22uH			ELJ-FC220K	L1690201		1-	A	
Q 1001	IC				TK71650SCL	G1093136		1-	A	
Q 1002	TRANSISTOR				DTC114TE TL	G3070225		1-	A	
Q 1003	IC				PIC17LC44-08/PQ	S8100917		1-	A	
Q 1004	TRANSISTOR				2SC4617 TL R	G3346178R		1-	A	
Q 1005	IC				MD09	G1093276		1-	A	
Q 1006	IC				BR93LC66FV-E2	G1092853		1-	A	
R 1001	CHIP RES.	18k	1/16W	5%	RMC1/16S 183JTH	J24189040		1-	A	
R 1002	CHIP RES.	0	1/16W	5%	RMC1/16S JPTH	J24189070		1-	A	
R 1003	CHIP RES.	82k	1/16W	5%	RMC1/16S 823JTH	J24189048		1-	A	
R 1004	CHIP RES.	0	1/16W	5%	RMC1/16S JPTH	J24189070		1-	A	
R 1005	CHIP RES.	470k	1/16W	5%	RMC1/16S 474JTH	J24189057		1-	A	
R 1006	CHIP RES.	1M	1/16W	5%	RMC1/16S 105JTH	J24189061		1-	A	
R 1007	CHIP RES.	22k	1/16W	5%	RMC1/16S 223JTH	J24189041		1-	A	
R 1008	CHIP RES.	1k	1/16W	5%	RMC1/16S 102JTH	J24189025		1-	A	
R 1009	CHIP RES.	100k	1/16W	5%	RMC1/16S 104JTH	J24189049		1-	A	
R 1010	CHIP RES.	5.6k	1/16W	5%	RMC1/16S 562JTH	J24189034		1-	A	
R 1011	CHIP RES.	10k	1/16W	5%	RMC1/16S 103JTH	J24189037		1-	A	
R 1012	CHIP RES.	22k	1/16W	5%	RMC1/16S 223JTH	J24189041		1-	A	
R 1013	CHIP RES.	47k	1/16W	5%	RMC1/16S 473JTH	J24189045		1-	A	
R 1014	CHIP RES.	33k	1/16W	5%	RMC1/16S 333JTH	J24189043		1-	A	
R 1015	CHIP RES.	10k	1/16W	5%	RMC1/16S 103JTH	J24189037		1-	A	
R 1016	CHIP RES.	47k	1/16W	5%	RMC1/16S 473JTH	J24189045		1-	A	
R 1017	CHIP RES.	47k	1/16W	5%	RMC1/16S 473JTH	J24189045		1-	A	
R 1018	CHIP RES.	47k	1/16W	5%	RMC1/16S 473JTH	J24189045		1-	A	
R 1019	CHIP RES.	330k	1/16W	5%	RMC1/16S 334JTH	J24189055		1-	A	
R 1020	CHIP RES.	82k	1/16W	5%	RMC1/16S 823JTH	J24189048		1-	A	
R 1021	CHIP RES.	15k	1/16W	5%	RMC1/16S 153JTH	J24189039		1-	A	
R 1022	CHIP RES.	10k	1/16W	5%	RMC1/16S 103JTH	J24189037		1-	A	
R 1023	CHIP RES.	100k	1/16W	5%	RMC1/16S 104JTH	J24189049		1-	A	
X 1001	XTAL 94SMX	8MHZ			8.000MHZ	H0103248		1-	A	
	BLIND SHEET					RA0109300		1-		

FVP-25 Encryption / DTMF Pager Unit

Circuit Diagram

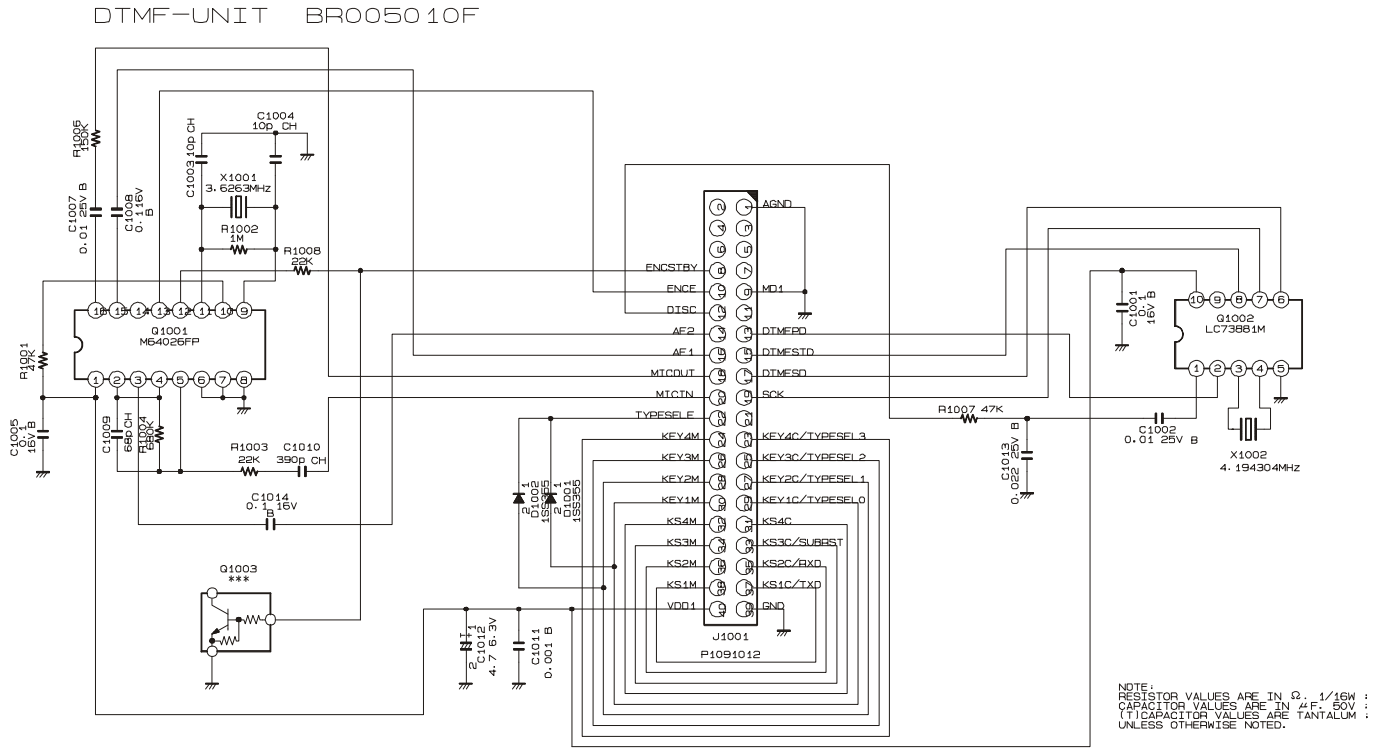

Parts Layout

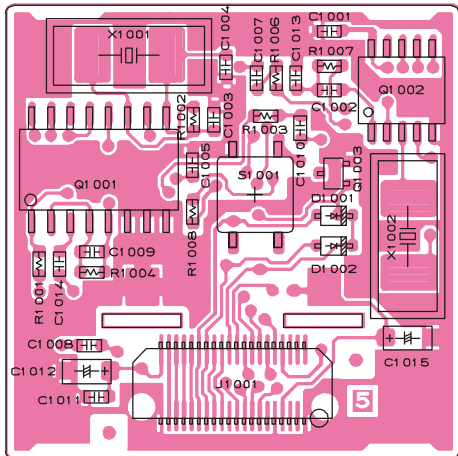

Side A

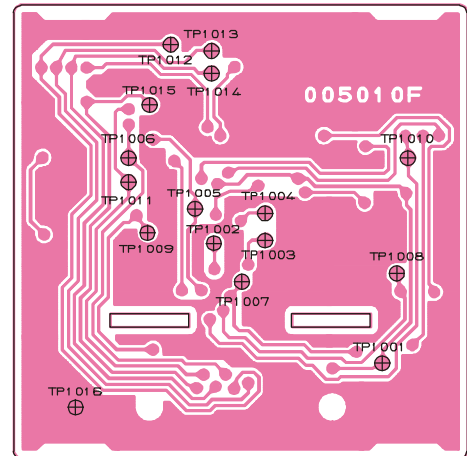

Side B

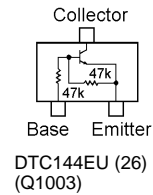
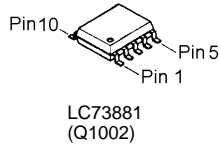
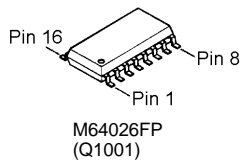

FVP-25 Encryption / DTMF Pager Unit

Parts List

REF.	DESCRIPTION	VALUE	V/W	TOL.	MFR'S DESIG	VXSTD P/N	VERS.	LOT.	SIDE	LAY ADR
*** FVP-25 ***										
Printed Circuit Board						FR005010F		1-		
C 1001	CHIP CAP.	0.1uF	16V	B	GRM39B104K16PT	K22124805		1-	A	B1
C 1002	CHIP CAP.	0.01uF	25V	B	GRM39B103M25PT	K22144802		1-	A	B1
C 1003	CHIP CAP.	10pF	50V	CH	GRM39CH100D50PT	K22174211		1-	A	A1
C 1004	CHIP CAP.	10pF	50V	CH	GRM39CH100D50PT	K22174211		1-	A	A1
C 1005	CHIP CAP.	0.1uF	16V	B	GRM39B104K16PT	K22124805		1-	A	A1
C 1007	CHIP CAP.	0.1uF	16V	B	GRM39B104K16PT	K22124805		1-	A	A1
C 1007	CHIP CAP.	0.01uF	25V	B	GRM39B103M25PT	K22144802		32-	A	A1
C 1008	CHIP CAP.	0.1uF	16V	B	GRM39B104K16PT	K22124805		1-	A	A2
C 1009	CHIP CAP.	68pF	50V	CH	GRM39CH680J50PT	K22174231		1-	A	A1
C 1010	CHIP CAP.	390pF	50V	CH	GRM39CH391J50PT	K22174255		1-	A	A1
C 1011	CHIP CAP.	0.001uF	50V	B	GRM39B102K50PT	K22174821		1-	A	A2
C 1012	CHIP TA.CAP.	4.7uF	6.3V		TEMSVA0J475M-8R	K78080017		1-	A	A2
C 1013	CHIP CAP.	0.022uF	25V	B	GRM39B223K25PT	K22144807		1-	A	A1
C 1014	CHIP CAP.	0.1uF	16V	B	GRM39B104K16PT	K22124805		1-	A	A1
D 1001	DIODE				1SS355 TE-17	G2070470		1-	A	B1
D 1002	DIODE				1SS355 TE-17	G2070470		1-	A	B1
J 1001	CONNECTOR				AXK5S40035P	P1091012		1-	A	A2
Q 1001	IC				M64026FP-650C	G1092754		1-	A	A1
Q 1002	IC				LC73881M-TLM	G1092755		1-	A	B1
Q 1003	TRANSISTOR				DTC144EU T106	G3070041		1-	A	B1
R 1001	CHIP RES.	47k	1/16W	5%	RMC1/16 473JATP	J24185473		1-	A	A1
R 1002	CHIP RES.	1M	1/16W	5%	RMC1/16 105JATP	J24185105		1-	A	A1
R 1003	CHIP RES.	22k	1/16W	5%	RMC1/16 223JATP	J24185223		1-	A	A1
R 1004	CHIP RES.	680k	1/16W	5%	RMC1/16 684JATP	J24185684		1-	A	A1
R 1006	CHIP RES.	150k	1/16W	5%	RMC1/16 154JATP	J24185154		1-	A	A1
R 1007	CHIP RES.	47k	1/16W	5%	RMC1/16 473JATP	J24185473		1-	A	B1
R 1008	CHIP RES.	10k	1/16W	5%	RMC1/16 103JATP	J24185103		1-	A	A1
R 1008	CARBON FILM RES.	22k	1/8W	5%	RD18TJ223 22K	J01215223		14-	A	A1
R 1008	CHIP RES.	22k	1/16W	5%	RMC1/16 223JATP	J24185223		17-	A	A1
X 1001	XTAL SX-1315	3.6263MHz			3.6263MHZ	H0103183		1-	A	A1
X 1002	XTAL SX-1315	4.194304MHz			4.194304MHZ	H0103184		1-	A	B1
	BLIND SHEET					RA0109300		1-		

VTP-50 VX-Trunk Unit

Circuit Diagram

VX-TRUNK-UNIT BR002540C

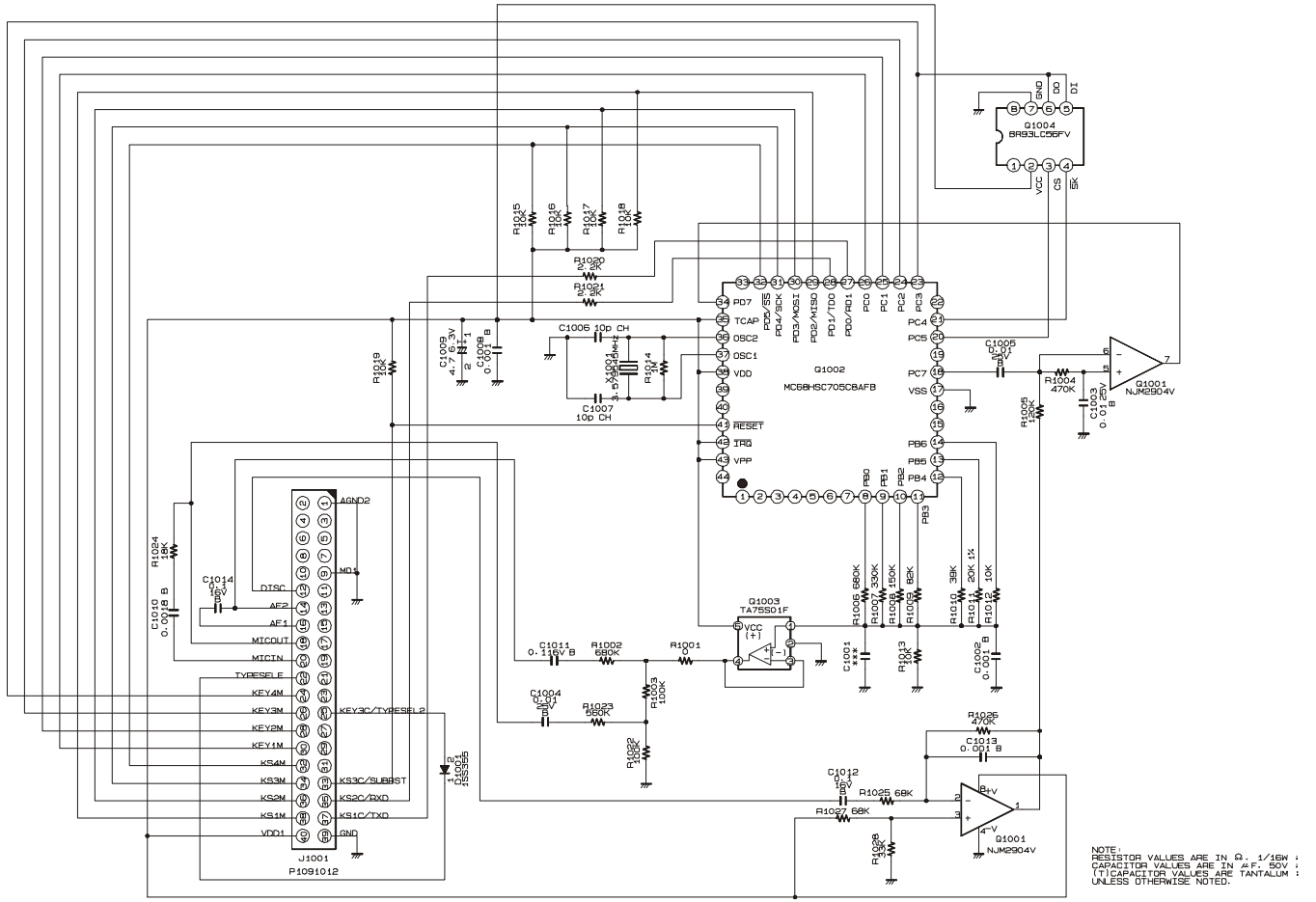

Parts Layout

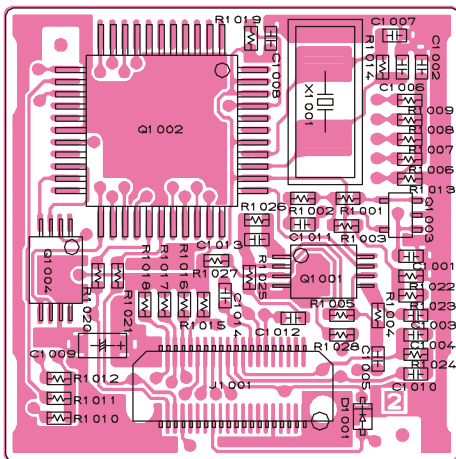

Side A

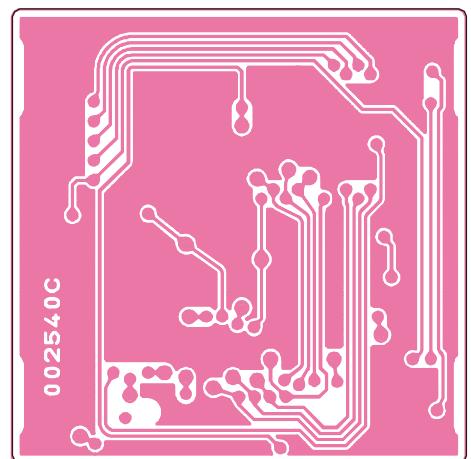

Side B

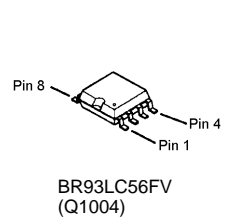
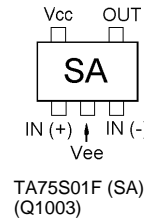
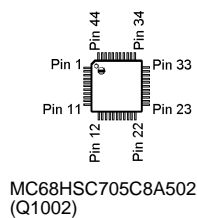
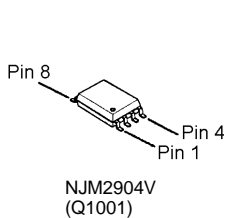

VTP-50 VX-Trunk Unit

Parts List

REF.	DESCRIPTION	VALUE	V/W	TOL.	MFR'S DESIG	VXSTD P/N	VERS.	LOT.	SIDE	LAY ADR
*** VTP-50 ***										
Printed Circuit Board						FR002540C		1-		
C 1002	CHIP CAP.	0.001uF	50V	B	GRM39B102K50PT	K22174821		1-	A	
C 1003	CHIP CAP.	0.01uF	25V	B	GRM39B103M25PT	K22144802		1-	A	
C 1003	CHIP CAP.	0.01uF	25V	B	GRM39B103K25PT	K22144803		9-	A	
C 1004	CHIP CAP.	0.1uF	16V	B	GRM39B104K16PT	K22124805		1-	A	
C 1004	CHIP CAP.	0.01uF	25V	B	GRM39B103K25PT	K22144803		9-	A	
C 1005	CHIP CAP.	0.01uF	25V	B	GRM39B103M25PT	K22144802		1-	A	
C 1005	CHIP CAP.	0.01uF	25V	B	GRM39B103K25PT	K22144803		9-	A	
C 1006	CHIP CAP.	10pF	50V	CH	GRM39CH100C50PT	K22174248		1-	A	
C 1007	CHIP CAP.	10pF	50V	CH	GRM39CH100C50PT	K22174248		1-	A	
C 1008	CHIP CAP.	0.001uF	50V	B	GRM39B102K50PT	K22174821		1-	A	
C 1009	CHIP TA.CAP.	4.7uF	6.3V		TEMSVA0J475M-8R	K78080017		1-	A	
C 1010	CHIP CAP.	0.0018uF	50V	B	GRM39B182M50PT	K22174812		1-	A	
C 1011	CHIP CAP.	0.1uF	16V	B	GRM39B104K16PT	K22124805		1-	A	
C 1012	CHIP CAP.	0.1uF	16V	B	GRM39B104K16PT	K22124805		1-	A	
C 1013	CHIP CAP.	0.001uF	50V	B	GRM39B102K50PT	K22174821		1-	A	
C 1014	CHIP CAP.	0.1uF	16V	B	GRM39B104K16PT	K22124805		1-	A	
D 1001	DIODE				1SS355 TE-17	G2070470		1-	A	
J 1001	CONNECTOR				AXK5S40035P	P1091012		1-	A	
Q 1001	IC				NJM2904V-TE1	G1091677		1-	A	
Q 1002	IC				MC68HSC705C8A502-6030 130	G1092917		1-	A	
Q 1002	IC				MC68HSC705C8A502-6030 131	G1093326		6-	A	
Q 1003	IC				TA75S01F TE85R	G1091593		1-	A	
Q 1004	IC				BR93LC56FV-E2	G1092787		1-	A	
R 1001	CHIP RES.	0	1/16W	5%	RMC1/16 000JATP	J24185000		1-	A	
R 1002	CHIP RES.	680k	1/16W	5%	RMC1/16 684JATP	J24185684		1-	A	
R 1003	CHIP RES.	100k	1/16W	5%	RMC1/16 104JATP	J24185104		1-	A	
R 1004	CHIP RES.	470k	1/16W	5%	RMC1/16 474JATP	J24185474		1-	A	
R 1005	CHIP RES.	120k	1/16W	5%	RMC1/16 124JATP	J24185124		1-	A	
R 1006	CHIP RES.	680k	1/16W	5%	RMC1/16 684JATP	J24185684		1-	A	
R 1007	CHIP RES.	330k	1/16W	5%	RMC1/16 334JATP	J24185334		1-	A	
R 1008	CHIP RES.	150k	1/16W	5%	RMC1/16 154JATP	J24185154		1-	A	
R 1009	CHIP RES.	82k	1/16W	5%	RMC1/16 823JATP	J24185823		1-	A	
R 1010	CHIP RES.	39k	1/16W	5%	RMC1/16 393JATP	J24185393		1-	A	
R 1011	CHIP RES.	20k	1/16W	1%	RMC1/16 203FTP	J24183203		1-	A	
R 1012	CHIP RES.	10k	1/16W	5%	RMC1/16 103JATP	J24185103		1-	A	
R 1013	CHIP RES.	10k	1/16W	5%	RMC1/16 103JATP	J24185103		1-	A	
R 1014	CHIP RES.	1M	1/16W	5%	RMC1/16 105JATP	J24185105		1-	A	
R 1015	CHIP RES.	10k	1/16W	5%	RMC1/16 103JATP	J24185103		1-	A	
R 1016	CHIP RES.	10k	1/16W	5%	RMC1/16 103JATP	J24185103		1-	A	
R 1017	CHIP RES.	10k	1/16W	5%	RMC1/16 103JATP	J24185103		1-	A	
R 1018	CHIP RES.	10k	1/16W	5%	RMC1/16 103JATP	J24185103		1-	A	
R 1019	CHIP RES.	10k	1/16W	5%	RMC1/16 103JATP	J24185103		1-	A	
R 1020	CHIP RES.	2.2k	1/16W	5%	RMC1/16 222JATP	J24185222		1-	A	
R 1021	CHIP RES.	2.2k	1/16W	5%	RMC1/16 222JATP	J24185222		1-	A	
R 1022	CHIP RES.	100k	1/16W	5%	RMC1/16 104JATP	J24185104		1-	A	
R 1023	CHIP RES.	560k	1/16W	5%	RMC1/16 564JATP	J24185564		1-	A	
R 1024	CHIP RES.	18k	1/16W	5%	RMC1/16 183JATP	J24185183		1-	A	
R 1025	CHIP RES.	68k	1/16W	5%	RMC1/16 683JATP	J24185683		1-	A	
R 1026	CHIP RES.	470k	1/16W	5%	RMC1/16 474JATP	J24185474		1-	A	
R 1027	CHIP RES.	68k	1/16W	5%	RMC1/16 683JATP	J24185683		1-	A	
R 1028	CHIP RES.	33k	1/16W	5%	RMC1/16 333JATP	J24185333		1-	A	
X 1001	XTAL SX-1315	3.579545MHZ			3.579545MHZ	H0103185		1-	A	
	BLIND SHEET					RA0109300		1-		



Copyright © 2002

VERTEX STANDARD CO., LTD.

All rights reserved

No portion of this manual may be reproduced without the permission of VERTEX STANDARD CO., LTD.



E C O O 5 N 9 0 1

Printed in Japan.