



# UHF FM Transceiver VX-4000U Service Manual

©2002 VERTEX STANDARD CO., LTD. Printed in Japan.

**VERTEX STANDARD CO., LTD.**  
4-8-8 Nakameguro, Meguro-Ku, Tokyo 153-8644, Japan

**VERTEX STANDARD**

**US Headquarters**  
10900 Walker Street, Cypress, CA 90630, U.S.A.

**International Division**  
8350 N.W. 52nd Terrace, Suite 201, Miami, FL 33166, U.S.A.

**YAESU EUROPE B.V.**  
P.O. Box 75525, 1118 ZN Schiphol, The Netherlands

**YAESU UK LTD.**  
Unit 12, Sun Valley Business Park, Winnall Close  
Winchester, Hampshire, SO23 0LB, U.K.

**VERTEX STANDARD HK LTD.**  
Unit 5, 20/F., Seaview Centre, 139-141 Hoi Bun Road,  
Kwun Tong, Kowloon, Hong Kong

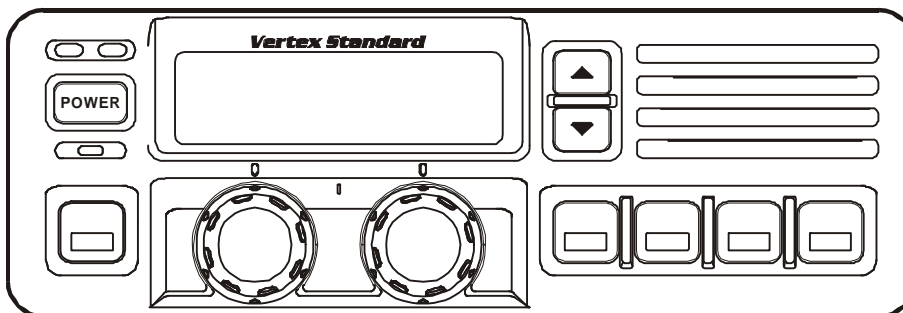

## Introduction

This manual provides technical information necessary for servicing the VX-4000U FM Transceiver.

Servicing this equipment requires expertise in handling surface-mount chip components. Attempts by non-qualified persons to service this equipment may result in permanent damage not covered by the warranty, and may be illegal in some countries.

Two PCB layout diagrams are provided for each double-sided circuit board in the Transceiver. Each side of is referred to by the type of the majority of components installed on that side (“leaded” or “chip-only”). In most cases one side has only chip components, and the other has either a mixture of both chip and leaded components (trimmers, coils, electrolytic capacitors, ICs, etc.), or leaded components only.

While we believe the technical information in this manual to be correct, VERTEX STANDARD assumes no liability for damage that may occur as a result of typographical or other errors that may be present. Your cooperation in pointing out any inconsistencies in the technical information would be appreciated.

## Contents

<b>Operating Manual Reprint</b> .....	<b>1-1</b>
<b>Cloning</b> .....	<b>2-1</b>
<b>Specifications</b> .....	<b>2-2</b>
<b>Exploded View &amp; Miscellaneous Parts</b> ...	<b>3-1</b>
<b>Block Diagram</b> .....	<b>3-2</b>
<b>Interconnection Diagram</b> .....	<b>3-4</b>
<b>Circuit Description</b> .....	<b>4-1</b>
<b>Alignment</b> .....	<b>5-1</b>

### Board Unit (Schematics, Layouts & Parts)

MAIN Unit .....	6A-1
DISPLAY Unit .....	6B-1
KEY Unit .....	6C-1
VR Unit .....	6D-1
MIC CONN Unit .....	6D-2

### Optional Board Unit (Schematics, Layouts & Parts)

F2D-8 2-Tone Decode Unit .....	7A-1
F5D-14 5-Tone Unit .....	7B-1
FVP-25 Encryption / DTMF Pager Unit .....	7C-1
VTP-50 VX-Trunk Unit .....	7D-1



## CONTROLS & CONNECTORS

### Front Panel

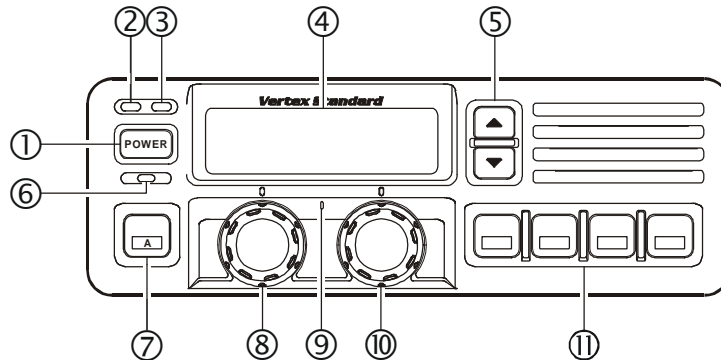

**① POWER Button**

Press the button to turn the transceiver ON and OFF.

**② TX Indicator**

This lamp glows red when the radio is transmitting.

**③ BUSY Indicator**

This lamp glows green when the channel is busy.

**④ Liquid Crystal Display**

The display include an 8-character alpha-numeric section showing channel and group names, status and identity information, and error messages. Additional indicators on the display show priority channel assignments and scan include / exclude selection.

**⑤ ▲/▼ Button**

Pressing these buttons changes the current group (and displayed group number or name). Holding this button for more than 1/2 second causes the function to repeat.

**⑥ SQC Indicator**

This lamp glows orange when incorrect position at the setting of CE35.

**⑦ Programmable Function Button (PF button)**

This button can be set up for special applications, such as high/low power selection, monitor, dimmer, talk-around, and call alert function, as determined by your network requirements and programmed by your VERTEX STANDARD dealer.

**⑧ VOLUME Knob**

This knob sets the volume of the receiver.

**⑨ EMERGENCY Microphone**

The emergency microphone is located behind this small slit. When the emergency feature is activated, this Microphone is enabled.

**⑩ CHANNEL Selector Knob**

This knob select the operating channel.

**⑪ Programmable Function Button (PF button)**

This button can be set up for special applications, such as high/low power selection, monitor, dimmer, talk-around, and call alert function, as determined by your network requirements and programmed by your VERTEX STANDARD dealer.

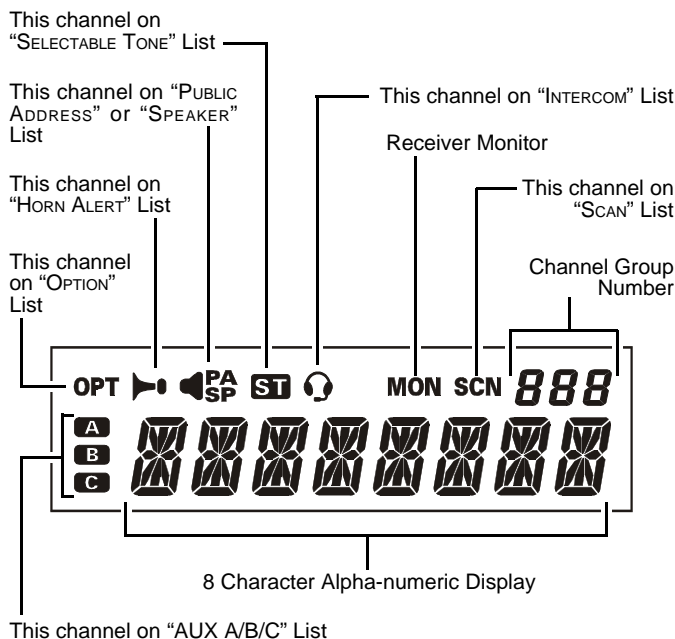

## CONTROLS & CONNECTORS

### Side Panel

**Microphone Jack** (It is on both sides.)  
Connect the microphone plug to this jack.

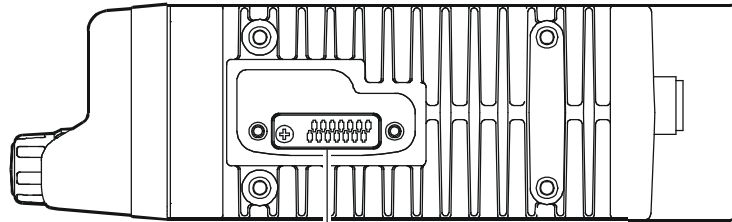

Microphone Jack

### REAR (Heatsink)

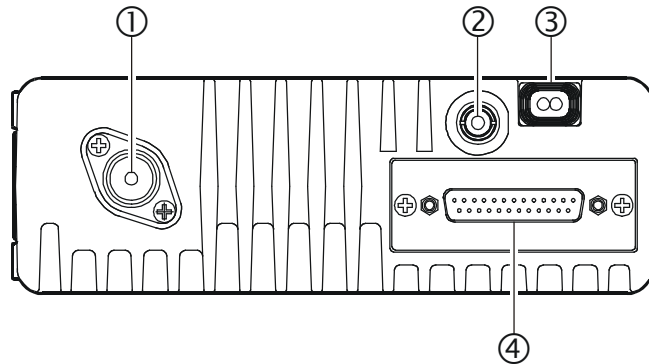

① **Antenna Socket**

The 50-ohm coaxial feedline to the antenna must be connected here, using a type-M (PL-259) plug.

② **External Speaker Jack**

An external loudspeaker may be connected to this 2-contact, 3.5-mm mini-phone jack.

**Caution:** Do not connect this line to ground, and be certain that the speaker has adequate capability to handle the audio output from the VX-4000.

③ **13.8-V DC Cable Pigtail w/Connector**

The supplied DC power cable must be connected to this 2-pin connector. Use only the supplied fused cable, extended if necessary, for power connection.

④ **DSUB 25-Pin Accessory Connector**

External TX audio line input, PTT (Push To Talk), Squelch, and external RX audio line output signal may be obtained from this connector for use with accessories such as data transmission/reception modems, etc.

---

## BASIC OPERATION OF THE TRANSCEIVER

---

**Important!** - Before turning on the radio the first time, confirm that the power connections have been made correctly and that a proper antenna is connected to the antenna jack.

### Switching Power ON/OFF

Push the **POWER** switch turn on the radio. The display will become illuminated. The radio will start up on the last channel used prior to shut-down during the previous operating session.

Turn the **CHANNEL** selector knob to choose the desired operating channel. A channel name will appear on the display. If you want to select the operating channel from a different Memory Channel Group, press the **UP** (▲) or **DOWN** (▼) button to select the Memory Channel Group you want before selecting the operating channel.

### Setting the Volume

Turn the **VOLUME** knob clockwise to increase the volume, and counterclockwise to decrease it. If no signal is present, press and hold in the **MON** button more than 1/2 seconds; background noise will now be heard, and you may use this to set the **VOLUME** knob for the desired audio level. Press and hold the **MON** button more than 1/2 seconds to quiet the noise and resume normal (quiet) monitoring.

### Transmitting

To transmit, wait until the “**BUSY**” indicator is off (the channel is not in use), and press the **PTT** (Push-To-Talk) switch on the side of the microphone (the “**TX**” indicator will appear or the “**TX**” indicator will glow red). While holding in the **PTT** switch, speak across the face of the microphone in a clear, normal voice level, and then release the **PTT** switch to receive.

### Selecting Groups and Channels

- Press the **UP** (▲) or **DOWN** (▼) button (repeatedly, if necessary) to select a different group of channels.
- Turn the **CHANNEL** selector knob to select a different channel *within the current group*.

### Automatic Time-Out Timer

If the selected channel has been programmed for automatic time-out, you must limit the length of each transmission. While transmitting, a beep will sound five seconds before time-out. Another beep will sound just before the deadline; the “**TX**” indicator will disappear and transmission will cease soon thereafter. To resume transmitting, you must release the **PTT** and wait for the “penalty timer” to expire (if you press the **PTT** before this timer expires, the timer restarts, and you will have to wait another “penalty” period.)

## ADVANCED OPERATION

### Programmable Function Button (PF button)

The VX-4000 includes the seven **Programmable Function Buttons (PF button)**. The **PF** button functions can be customized, via programming by your VERTEX STANDARD dealer, to meet your communications/network requirements. Some features may require the purchase and installation of optional internal accessories. The possible **PF** button programming features are il-

lustrated at the below, and their functions are explained on next page. For further details, contact your VERTEX STANDARD dealer. For future reference, check the box next to each function that has been assigned to the **PF** button on your particular radio, and keep it handy.

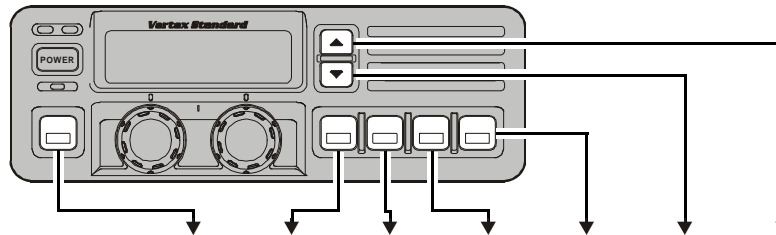

Functions	Programmable Function Button (PF button)													
	<1.5 sec	>1.5 sec	<1.5 sec	>1.5 sec	<1.5 sec	>1.5 sec	<1.5 sec	>1.5 sec	<1.5 sec	>1.5 sec	<1.5 sec	>1.5 sec	<1.5 sec	>1.5 sec
None														
SCAN (SCN)														
Dual Watch														
Call/Reset														
Talk-Around (TA)														
Noise Blanker* (NB)														
Alpha Numeric (A/N)														
DIMMER (DIM)														
Emergency (EMG)														
Horn Alert (HA)														
Home Channel (HOM)														
Intercom (IC)														
Low Power (LOW)														
GRP UP														
GRP DWN														
CH UP														
CH DWN														
AUX A														
AUX B														
AUX C														
Public Address (PA)														
Monitor (MON)														
RCL														
Selectable Tone (ST)														
SP**														
Squish Level (SQL)														
Encryption*** (OPT)														

\* for VX-4000L      \*\* requires RMK-4000      \*\*\* requires Encryption Unit

---

## ADVANCED OPERATION

---

### Channel Scan

The Scanning feature is used to monitor multiple signals programmed into the transceiver. While scanning, the transceiver will check each channel for the presence of a signal, and will stop on a channel if a signal is present.

#### To activate scanning:

- Press the assigned **PF** button of the “**Scan**” momentarily to activate scanning.
- The scanner will search the channels, looking for active ones; it will pause each time it finds a channel on which someone is speaking.

#### To stop scanning

- Press the assigned **PF** button of the “**Scan**”.
- Operation will revert to the channel to which the **CHANNEL** selector knob is set.

**Note:** Your dealer may have programmed your radio to stay on one of the following channels if you press the **PTT** switch during scanning pause:

- Current channel (“Talk Back”)
- “Last Busy” channel
- “Priority” channel
- “Home” channel
- Scan Start” channel

### Dual Watch

The Dual Watch feature is similar to the Scan feature, except that only two channels are monitored:

- The current operating channel; and
- The “Priority” channel.

#### To activate Dual Watch:

- Press the assigned **PF** button of the “**Dual Watch**”.
- The scanner will search the two channels; it will pause each time it finds a channel on which someone is speaking.

#### To stop Dual Watch:

- Press the assigned **PF** button of the “**Dual Watch**”.
- Operation will revert to the channel to which the **CHANNEL** selector knob is set.

### ARTS (Auto Range Transpond System)

This system is designed to inform you when you and another ARTS-equipped station are within communication range.

During ARTS operation, your radio automatically transmits for about 1 second every 25 (or 55) seconds (the interval is programmed by Dealer) in an attempt to Shake hands with the other station. If you move out of range for more than one minute, your radio senses that no signal has been received, a ringing beeper will sound. If you subsequently move back into range, as soon as the other station transmits, your beeper will sound.

### The PF Button Function

The **PF** (Programmable Function) button can be programmed by the dealer to provide two of the other functions described below.

To activate the primary Accessory function, press the **PF** button momentarily. To access the secondary Accessory function (which may include the Alarm), press and hold the **PF** button for 1.5 seconds or longer.

### Call/Reset

When this feature is programmed and a selective call has been received, momentarily press the assigned **PF** button of the “**Call/Reset**” to reset the flashing indicator and mute the receiver, otherwise press the assigned **PF** button of the “**Call/Reset**” to sent your radio’s identification code (ANI) to the dispatcher.

### Talk-Around

The feature causes the assigned **PF** button of the “**Talk-Around**” to select simplex operation on semi-duplex channels: the transmit frequency becomes the same as the receive frequency (regardless of any programmed offset for the channel).

**Note:** This feature has no effect on simplex channels. After pressing the button, “**TA**” is displayed on the LCD.

### Noise Blanker (for VX-4000L)

Because local noise can be particularly troublesome in the VHF Low-Band frequency spectrum, the Low-Band version of the VX-4000 includes a Noise Blanker feature, which may be toggled on and off by pressing the assigned **PF** button of the “**Noise Blanker**” for the appropriate length of time.

---

## ADVANCED OPERATION

---

### Alpha Numeric

Press the assigned **PF** button of the “**Alpha Numeric**” to switch the display between the Group/Channel number, and the Group/Channel name (alphanumeric). A tone will sound each time you switch between numerical and alphanumeric display.

### DIM

Press the assigned **PF** button of the “**DIM**” to adjust the brightness of the display and key backlight.

### EMG (Emergency)

Press the assigned **PF** button of the “**EMG**” to initiate an emergency call (requires ANI board). When an emergency call is made, no tone is emitted and the display does not change. To end the emergency call, turn the transceiver power OFF.

### HA (Horn Alert)

Press the assigned **PF** button of the “**HA**” to turn the Horn Alert function ON or OFF. If you receive a call from the base station with 2Tone or DTMF signaling, horn alert will activate. When you turn Horn Alert ON, a tone will sound and “” appears on the display.

### Home (Home Channel)

Press the assigned **PF** button of the “**Home**” to select the pre-programmed Home Channel. Press it again to return to the previous channel. If used while scanning, pressing this key a second time will change to the revert channel.

### IC (Intercom)

This feature requires dual head configuration. Press the assigned **PF** button of the “**IC**” to turn the intercom feature ON or OFF. While ON, you can press the PTT switch to communicate to another control head operator without transmitting over the air. When you press this key, a tone sounds and “” appears on the display. The intercom can be used even while scanning and receiving a call.

### Low Power

Press the assigned **PF** button of the “**Low Power**” to set the radio's transmitter to the “Low Power” mode. Press this key again to return to “High Power” operation when in difficult terrain.

### GRP UP/DWN

Press the assigned **PF** button of the “**GRP UP**” or “**GRP DWN**” to select a different group of channels.

### CH UP/DWN

Press the assigned **PF** button of the “**CH UP**” or “**CH DWN**” to select a different channel within the current group.

### AUX A/B/C

Press the assigned **PF** button of the “**AUX A**”, “**AUX B**”, or “**AUX C**” to turn the output port (respectively).

### PA (Public Address)

Press the assigned **PF** button of the “**PA**” to use the transceiver as a PA amplifier. When you enable this function, a tone sounds and “PA” appears on the display. The public address can be used even while scanning and receiving a call.

### MONI (Monitor)

Press the assigned **PF** button of the “**MONI**” momentarily to cancel CTCSS and DCS signaling squelch; the “**MON**” icon appears on the display. Press and hold this key for 1/2 seconds to hear background noise (unmute the audio); the **MON** icon blinks on the display.

### RCL (Channel Recall)

During scan, you can press the assigned **PF** button of the “**RCL**” to select the last called channel.

### ST (Selectable Tone)

Press the assigned **PF** button of the “**Selectable Tone**”, then rotate the CHANNEL selector knob to select a 2-Tone.

### SP

Press the assigned **PF** button of the “**SP**” to switch “Front panel”, “Front panel & Body” and “Body” speaker. When “Body” is selected, a tone sounds and the “SP” icon appears on the display. You can use this function while scanning and receiving a call. However, all audio will be emitted from the PA speaker.



## ADVANCED OPERATION

---

### **SQL (Squelch Level)**

You can manually adjust the squelch level using this function:

1. Press the assigned **PF** button of the “**SQL**”. A tone sounds and SQL appears on the display with the current squelch level.
2. Rotate the **CHANNEL** selector knob to select the desired level.
3. Press the this key. A tone sounds and the display returns to the normal channel.

### **Encryption (Option)**

When the Voice Scrambler feature is enabled, pressing the assigned **PF** button of the “**Encryption**” toggles the Scrambler on and off.

---

## OPTIONAL ACCESSORIES

---

<b>MH-25</b> <sub>B7A</sub>	Microphone
<b>MH-53</b> <sub>C7A</sub>	Heavy Duty Microphone
<b>MH-53</b> <sub>A7A</sub>	Heavy Duty Microphone w/Noise Canceler
<b>MH-53</b> <sub>B7A</sub>	Heavy Duty DTMF Microphone w/Noise Canceler
<b>CE35</b>	Programming Software
<b>CT-70</b>	Radio Programming Cable (Requires VPL-1)
<b>CT-71</b>	Radio to PC Programming Cable
<b>CT-72</b>	Radio to Radio Programming Cable
<b>CT-81</b>	Cable for RMK-4000 (6 m)
<b>CT-82</b>	Cable for RMK-4000 (2.5 m)
<b>CT-83</b>	Cable for RMK-4000 (0.6 m)
<b>CNT-4000</b>	Control Head
<b>RF DECK</b>	RF Deck w/MMB-75 (for Dual Band Installations)
<b>RMK-4000SH</b>	Remote Kit (for Single Transceiver)
<b>RMK-4000DH</b>	Remote Kit (for Dual-Head Installations)
<b>RMK-4000DB</b>	Remote Kit (for Dual Band Installations)
<b>RMK-4000DBH</b>	Remote Kit (for Dual Band plus Dual Head Installations)
<b>F2D-8</b>	2-Tone Decode Unit (Requires FIF-7)
<b>F5D-14</b>	5-Tone ENC-DEC Unit (Requires FIF-7)
<b>VTP-50</b>	VX-Trunk Unit (Requires FIF-7)
<b>FVP-25</b>	Encryption/DTMF pager Unit (Requires FIF-7)
<b>FP-1023</b>	External 23A Power Supply
<b>MLS-100</b>	Mobile Loud speaker (12 W Peak Power)
<b>MMB-75</b>	Mobile Mounting Bracket
<b>MMB-76</b>	Locking Mobile Mounting Bracket
<b>LF-1</b>	Line Filter
<b>FIF-7</b>	Inter face Board (for F2D-8, F5D-14, VTP-50, FVP-25)
<b>CN-6</b>	Inter face Board (for Accessories)
<b>FIF-8</b>	Flash ROM Adapter

# DSUB 25-PIN ACCESSORY CONNECTOR

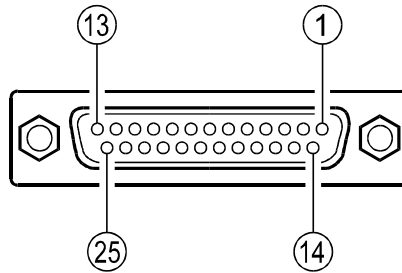

DSUB 25-Pin Numbering

## Pin 1: RSSI [Analog Output]

A DC voltage proportional to the strength of the signal currently being received (Receiver Signal Strength Indicator) is provided on this pin. This low impedance output is generated by the receiver IF sub-system and buffered by an internal op-amp. Typical voltages are graphed as follows:

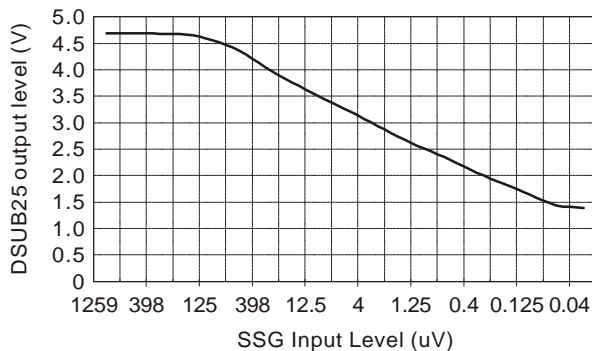

## Pin 2, 3, 4, 5 & 6: AI1, AI2, AI3, AI4 & AI5

[Universal Input Port]

These input port features can be programmed via the CE35 programmer. The same item can not be chosen twice.

To select the "Input port" page, (View  $\Rightarrow$  Common View  $\Rightarrow$  DSUB-25pin connector  $\Rightarrow$  Input port).

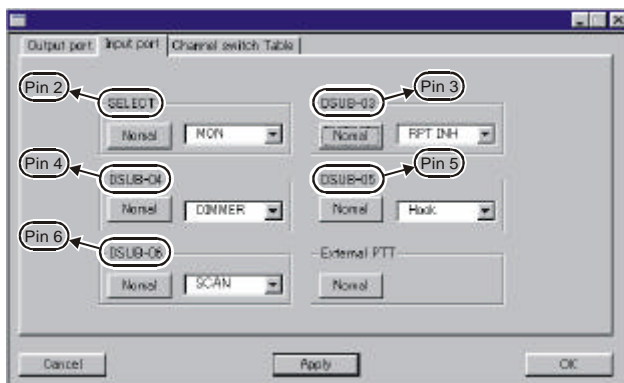

LOGIC level (+5V / 0V) input (Low active).  
High Impedance input.

**None**  
**MON**

This feature is the same as pressing and holding in the Monitor key.

**DIM**  
**Hook**

LCD illumination dimmer "on."  
Activates the Hook1 feature.

**SCAN**

Activates the scanner.

**G-SCAN**

Activates the Group scanner.

**RPT INH**

Disables the repeater feature during Multi Deck operation.

**ENG**

Activates the Emergency feature.

**Home**

Switches to the Home Channel.

**CH SW0**

Memory channel recall  
(Channel Switch Table bit 0)

**CH SW1**

Memory channel recall  
(Channel Switch Table bit 1)

**CH SW2**

Memory channel recall  
(Channel Switch Table bit 2)

**CH SW3**

Memory channel recall  
(Channel Switch Table bit 3)

## Example

If you assign "CH SW0" and "CH SW1" to the Universal Input Port, you can recall Channels 1-3 as shown below.

Channel	CH SW0	CH SW1
1	1	0
2	0	1
3	1	1

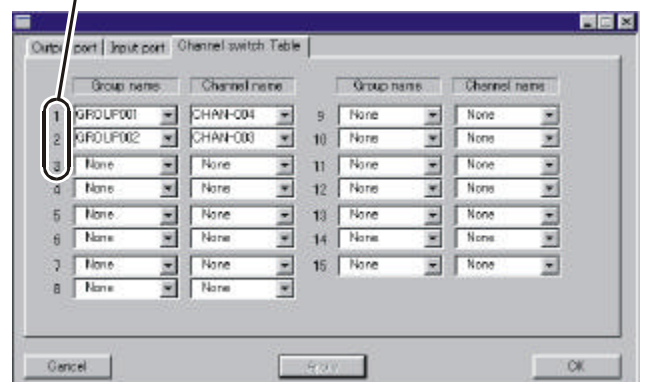

Similarly, if you assign “CH SW0,” “CH SW1,” and “CH SW2” to the Universal Input Port, you can recall Channels 1~7 as shown below:

Channel	CH SW0	CH SW1	CH SW2
1	1	0	0
2	0	1	0
3	1	1	0
4	0	0	1
5	1	0	1
6	0	1	1
7	1	1	1

If you need to recall all memory channels (15 CH) from the External Controller via the Universal Input Port, you should assign the “All Channel Recall” Command (CH SW 0 ~ CH SW 3) to the Universal Input Port.

In this case:

Channel	CH SW0	CH SW1	CH SW2	CH SW3
1	1	0	0	0
2	0	1	0	0
3	1	1	0	0
4	0	0	1	0
5	1	0	1	0
6	0	1	1	0
7	1	1	1	0
8	0	0	0	1
9	1	0	0	1
10	0	1	0	1
11	1	1	0	1
12	0	0	1	1
13	1	0	1	1
14	0	1	1	1
15	1	1	1	1

The Memory Channel is determined via the CE35 Programmer. (View Common View DSUB-25pin connector Channel switch Table).

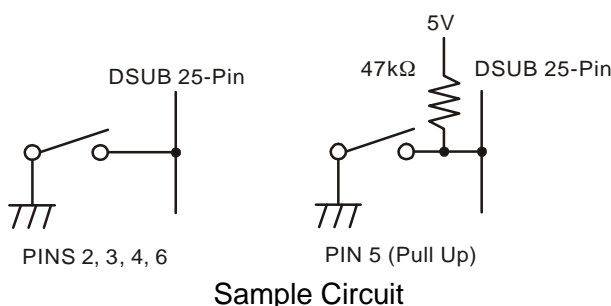
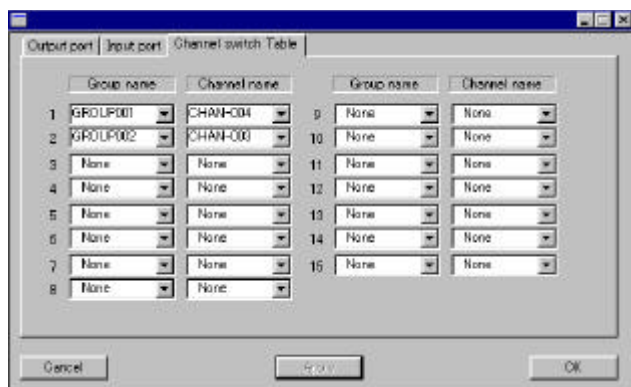

**Pin 7: E [GND]**

Ground for all logic levels and power supply return.

**Pin 8: AO2 [Universal Output Port]**

Open collector output. Output voltage 0 ~ 5 V, Max. sink current 30 mA.

The possible programming features (use CE35) are illustrated below.

**A KEY/B KEY/C KEY/D KEY/E KEY/HA/Invert**

Refer to the “Pins 20, 21, & 22” section for details.

**Pin 9: TXD2 [Digital Output for Alignment software]**

Connect to the RS232C cable (requires FIF-8 and CT-88)

**Pin 10: RXD2 [Digital Input for Alignment software]**

Connect to the RS232C cable (requires FIF-8 and CT-88)

**Pin 11: TXS [EXT PTT]**

Shorting this port to ground causes the transceiver to be placed in the Transmit mode, while opening the connection to this port returns the transceiver to the Receive mode.

**Pin 12: MCM [MIC Mute]**

MIC mute on: Level High (5V)

MIC mute off: Open

LOGIC level (+5V / 0V) output.

When the PTT/EXT PTT switch is pressed, this pin switches to “open.”

**Pin 13: MD/DI [Digital Input for DATA Communications]**

○ TX Hi-speed Data Input Type (jumper JP2006).

Input level 800 mV/600 Ohms, Max.input 1.2V

○ Tx Low-speed Data input Type (Jumper JP2007). Input level 40 mV/600-Ohms

If the Jumper setting is “Low-speed Data” (JP2007 jumpered), this port is usable in the AUDIO (300~3000 Hz) range.

If the jumper setting is “HI-speed Data” (JP2006 jumpered), this port is usable for 9600 bps DATA communications, because the filter and limiter are not engaged in the Audio line.

Maximum output current is 200 mA

**Pin 14: SB [13.8 V/5 V DC Output]**

○ Switched 13.8V output for supplying power to an accessory (jumper JP2009).

○ Switched and regulated DC 5.0V output for supplying power to an accessory (jumper JP2008).

Maximum output current is 200 mA

**Pin 15: IGN [Ignition Sense feature]**

The VX-4000 may automatically be switched to the STAND-BY mode when the vehicle's ignition key is turned on.

Maximum current is 20 mA.

This feature is only enabled on transceivers configured for Dual Deck operation.

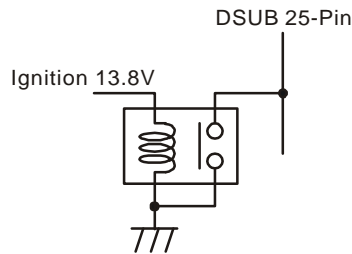

**Pin 16: NC [NO connection]**

**Pin 17: AFO [Digital Output for DATA Communications]**

- RX Hi-speed Data Output Type (jumper JP2004). output level 600 mV/10k Ohms
- RX Low-speed Data Output Type (jumper JP2005). output level 200 mV/600 Ohms

If the Jumper setting is "Low-speed Data" (JP2007 jumpered), this port is usable in the AUDIO (300~3000 Hz) range.

If the jumper setting is "HI-speed Data" (JP2006 jumpered), this port is usable for 9600 bps DATA communications, because the filter and limiter are not engaged in the Audio line.

**Pin 18: E [GND]**

Ground for all logic levels and power supply return.

**Pin 19: NC [No Connection]**

**Pins 20, 21, & 22: AO1, AO3 & AO4**

**[Universal Output Port]**

LOGIC level (+5V / 0V) output.

The logic output appears at these pins when the front panel's PF key is turned on.

The possible programming features (use CE35) are illustrated below.

If the HA feature is assigned to these ports, a current amplifier must be connected between the Horn circuit and the port.

**A KEY/B KEY/C KEY/D KEY/E KEY/HA/Invert**

**Pin 23: SQ [Squelch Signal Output]**

Open collector output. Max. sink current 10 mA.

A Signal is present (Squelch is open): Level High

No Signal is present (Squelch is closed): Open

When you connect the solder jumper on J2002, this port changes to PULL UP (5 V) output.

This status can be changed by CE35 programmer.

**Pin 24: SPM [Speaker Mute Output]**

Open collector output.

External Speaker mute on: Level High

External Speaker mute off: Open

**Pin 25: ME [GND]**

Chassis ground.

**Note:**

# Cloning

The **VX-4000** includes a convenient "Clone" feature, which allows the programming data from one transceiver to be transferred to another **VX-4000**. Here is the procedure for Cloning one radio's data to another.

**Note: When a cloning isn't made, you correct the following part using "CE35."**

**When a "Radio to Radio Clone" which is in the "Miscellaneous" menu is "Disabled," change this menu to "Enabled."**

1. Turn both transceivers off.
2. Remove the plastic cap and its two mounting screws from the **Microphone** jack on the transceiver. Do this for both transceivers.
3. Connect the optional **CT-72** cloning cable between the **Microphone** jacks of the two transceivers.
4. On the **Destination** transceiver, press and hold the **PF Button** (just below the **POWER Button**) while turning the transceiver on.
5. Now, on the **source** transceiver, press and hold the **▼ Button** while turning the transceiver on. Data will now be transferred to the **Destination** transceiver from the **source** transceiver.
6. If there is a problem during the cloning process, sound an error beep from source the transceiver. Check your cable connections and battery voltage, and try again.
7. If cloning is a successful, turn the **Destination** transceiver off. Now turn the **source** transceiver off.
8. Disconnect the **CT-72**. Replace the plastic cap and its two mounting screws.
9. You can then turn the transceivers back on, and begin normal operation.

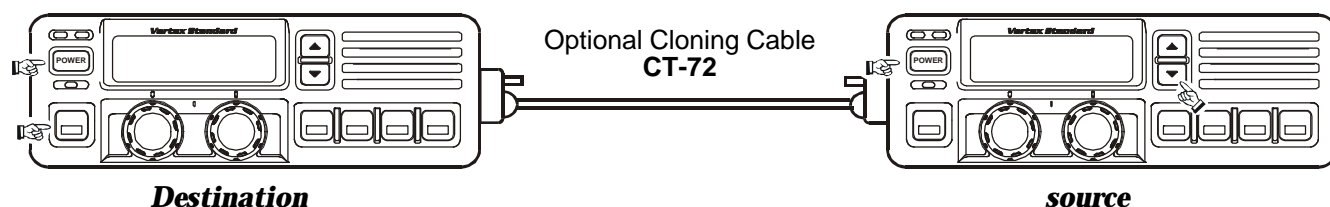

## Dealer Programming of VTP-50 and F5D-14

These procedures are designed to be used by the installing technician after the **VTP-50** and **F5D-14** has been installed in the transceiver. To program a **VX-4000's VTP-50** and **F5D-14** board, you will need the **CT-71** programming interface cable, the **CE-26** Programming diskette, and an IBM PC/AT or PS/2-compatible tyoe computer.

To enter the Programming mode, use the following procedure:

1. Turn the transceiver off.
2. Turn on the transceiver while holding in the **PF Button** (just below the **▼ Button**).

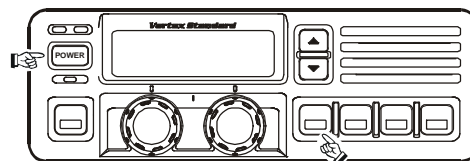

# Specifications

## GENERAL

<b>Number of Channels:</b>	250 channels
<b>Frequency Range:</b>	400 - 430 MHz (A), 450 - 480 MHz (D), 480 - 512 MHz (F)
<b>Channel Spacing:</b>	12.5 / 25 / 30 kHz
<b>Power Supply Voltage:</b>	13.8 VDC
<b>Current Consumption:</b>	Standby: 400 mA Receive: 2.1 A Transmit: 12 A
<b>Ambient Temperature Range:</b>	-30°C to +60°C (-22°F to +140°F)
<b>Frequency Stability:</b>	±2.5 ppm
<b>RF Input-Output Impedance:</b>	50 Ohms
<b>Audio Output Impedance:</b>	4 Ohms
<b>Dimensions:</b>	7" (w) x 2.4" (H) x 7.7" (D) (178 x 60 x 195 mm)
<b>Weight:</b>	4.9 lbs. (2.2 kg)

## RECEIVER (Measurements made per EIA standard TIA/EIA-603)

<b>Circuit Type:</b>	Double-conversion Super-heterodyne
<b>Sensitivity(EIA 12 dB SINAD):</b>	0.25 $\mu$ V
<b>Adjacent Channel Selectivity:</b>	80 dB / 70 dB
<b>Intermodulation:</b>	76 dB
<b>Spurious and Image Rejection:</b>	90 dB
<b>Audio Response:</b>	+3 / -8 dB from the 6 dB / oct. re-emphasis curve
<b>Audio Output:</b>	5 W @ 4 Ohms, 10 % THD 10 W @ 4 Ohms w/<10 % THD (Option)

## TRANSMITTER (Measurements made per EIA standard TIA/EIA-603)

<b>Power Output:</b>	40 / 25 W
<b>Modulation:</b>	16K0F3E, 11K0F3E
<b>Max Deviation:</b>	5.0 / 2.5 kHz
<b>Conducted Spurious Emissions:</b>	70 dB Below Carrier
<b>FM Hum &amp; Noise:</b>	45 dB (25 kHz) / 40 dB (12.5 kHz)
<b>Audio Response:</b>	+1 / -3 dB from the 6 dB / oct-8
<b>Audio Distortion (@ 1 kHz):</b>	< 3 %

*Measurements per EIA standards unless noted above.  
Specifications subject to change without notice or obligation.*



# Exploded View & Miscellaneous Parts

Screw List			
REF.	VXSTD P/N	Description	Qty.
1	U20306007	BINDING HEAD SCREW M3x6B	4
2	U20306002	BINDING HEAD SCREW M3x6NI	6
3	U24308002	TAPTITE SCREW M3x8NI	9
4	U23206001	TAPTITE SCREW M2.6x6	14
5	U20308002	BINDING HEAD SCREW M3x8NI	2
6	U24208001	TAPTITE SCREW M2.6x8	1
7	U20305007	BINDING HEAD SCREW M3x5B	2
8	U32450007	FLAT HEAD SCREW M2.6x5B	2
9	U31306007	OVAL HEAD SCREW M3x6B	2
10	S5000182	SCREW JFS-4S-B1MW	2

Accessories		
Description	VXSTD P/N	Qty.
BLADE FUSE ATC 15A	Q0000075	2
DC CABLE 02P 15AX2	T9021015	1
KNOB CAP	RA0254100	5
NAME PLATE	RA0254700	1

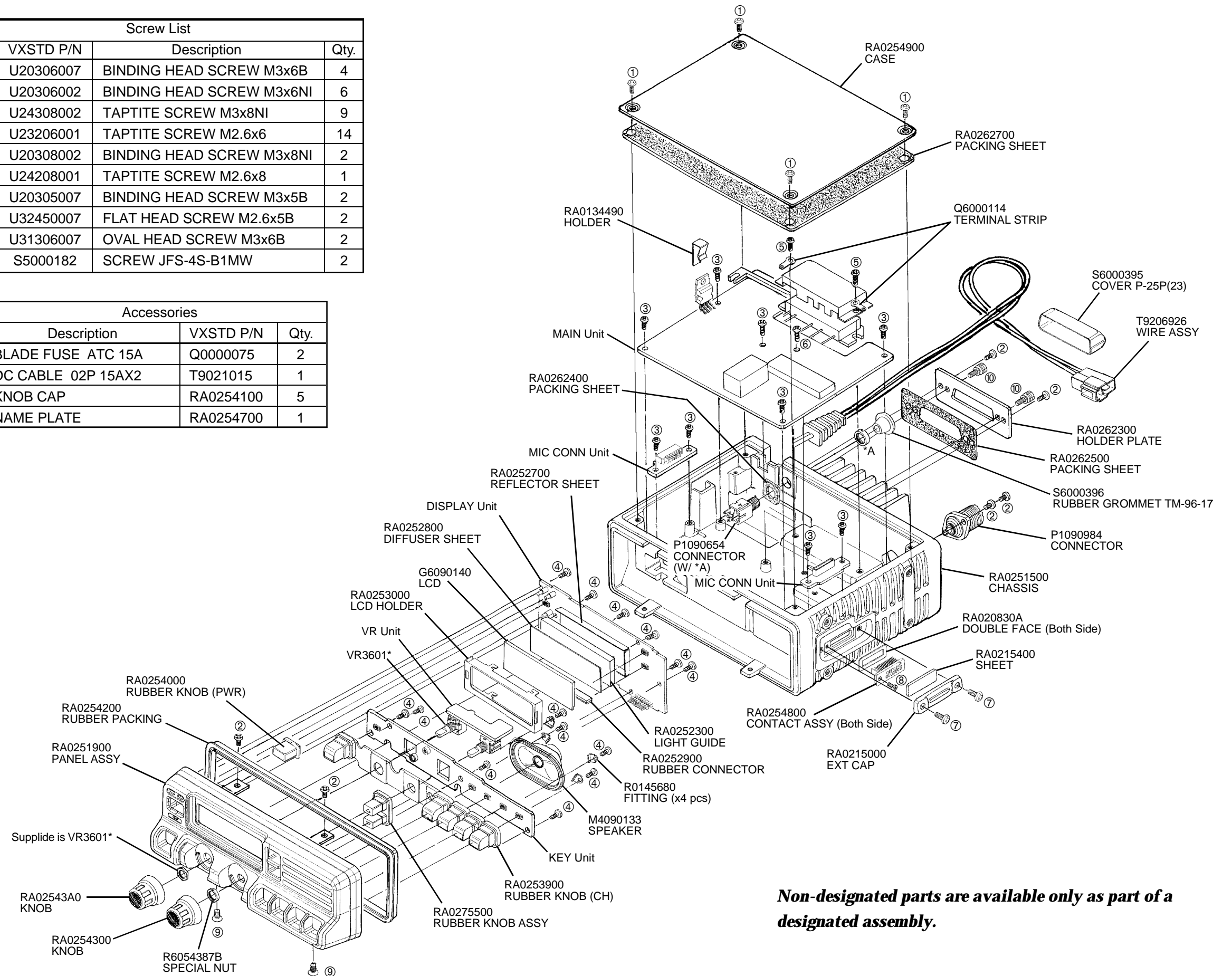

**Non-designated parts are available only as part of a designated assembly.**

# Block Diagram

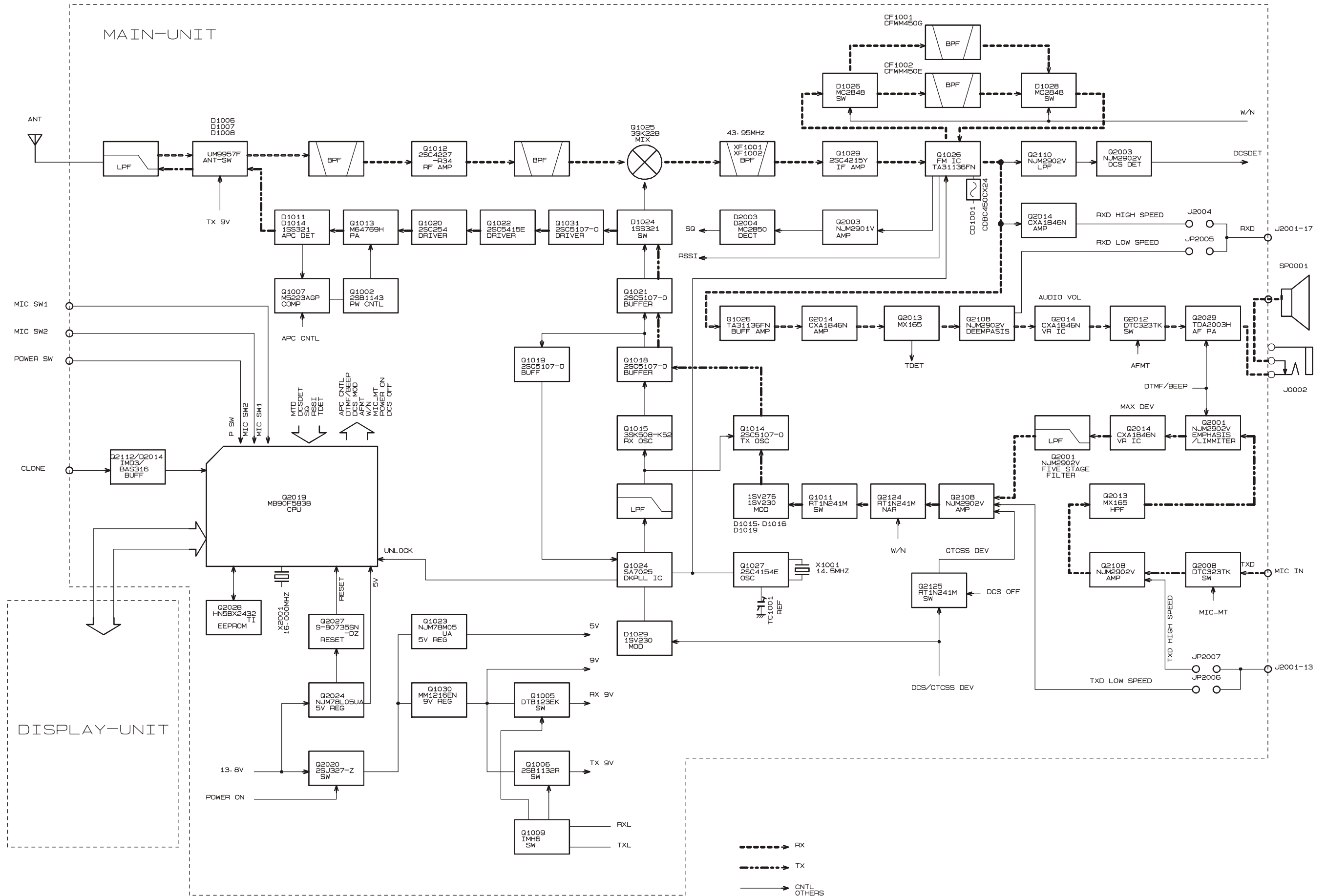

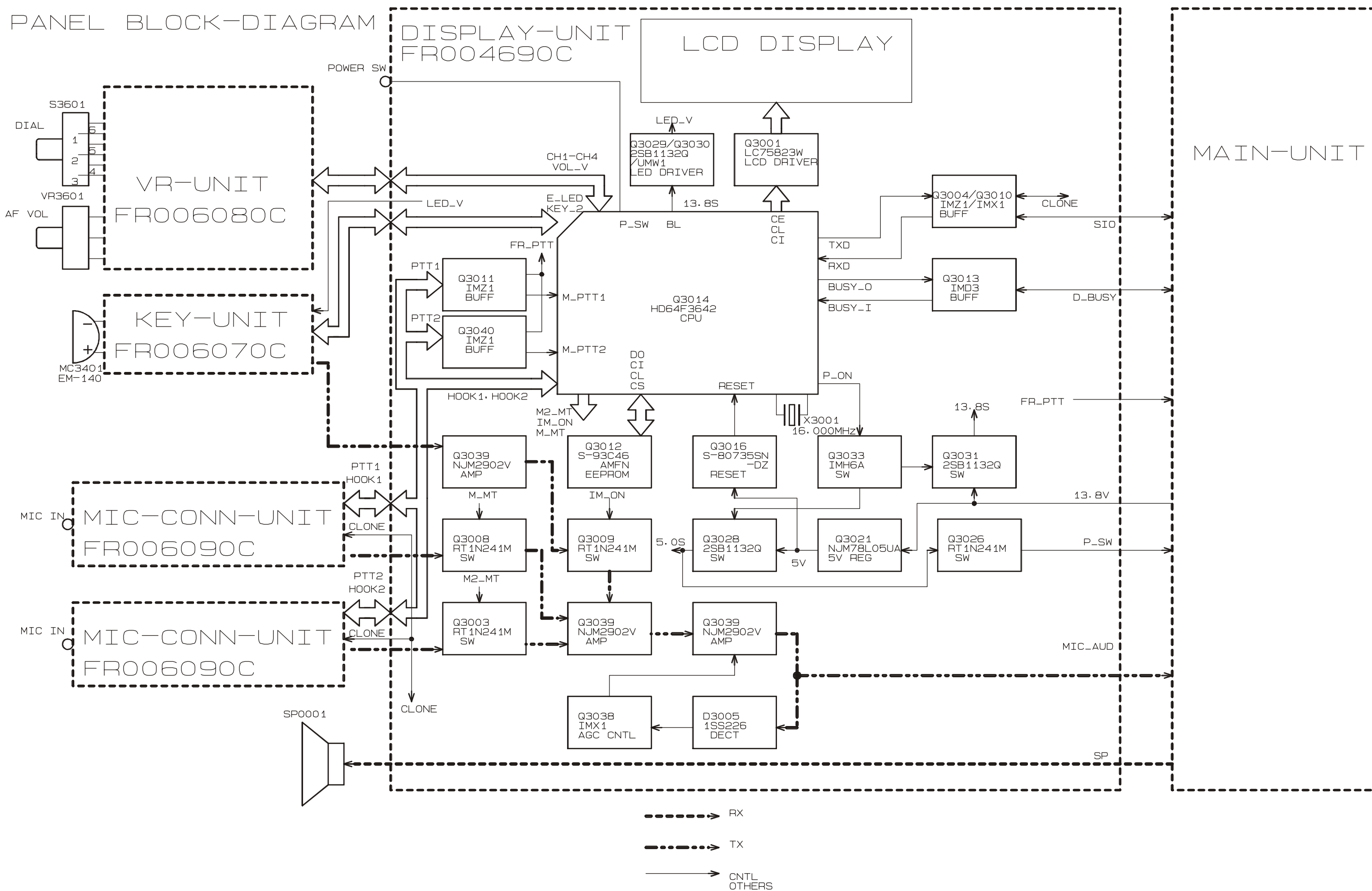

# Interconnection Diagram

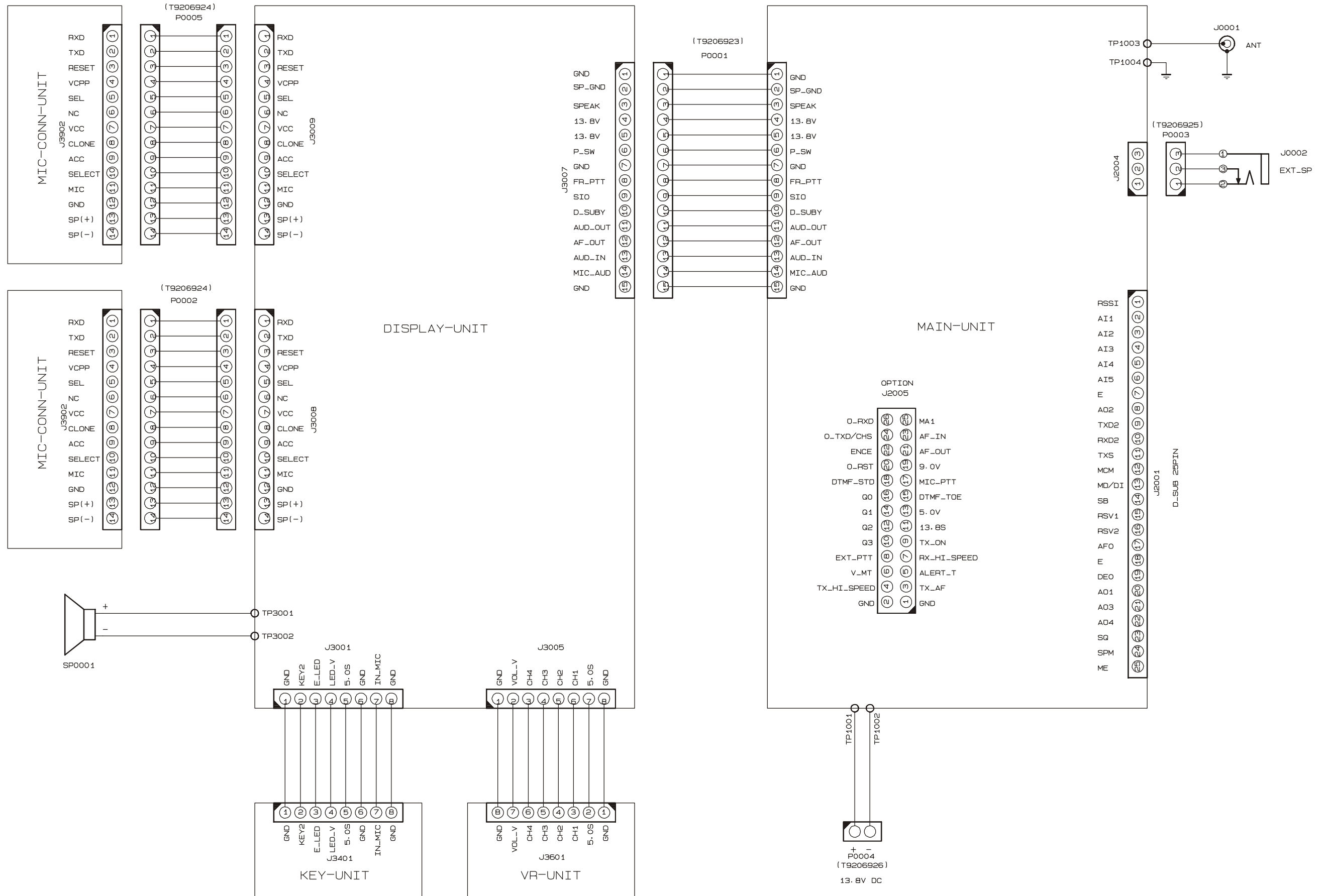

# Circuit Description

Reception and transmission are switched by "RX" and "TX" lines from the microprocessor unit (MPU).

## Main Receiver Signal Path

The receiver uses double-conversion superheterodyne circuitry, with a 43.95MHz 1st IF and 450 kHz 2nd IF. The 1st LO, produced by a PLL synthesizer, yields the 43.95MHz 1st IF.

The 2nd LO uses a 43.5 MHz (43.95 MHz-450 kHz) signal generated by a crystal oscillator. The 2nd mixer and other circuits use a custom IC to convert and amplify the 2nd IF, and detect FM to obtain demodulated signals.

During transmit, the PLL synthesizer oscillates at the desired frequency directly, for amplification to obtain RF power output. During transmit, voice modulation and CTCSS (or DCS) modulation are applied to this synthesizer. Transceiver functions, such as TX/RX control, PLL synthesizer settings, and channel programming, are controlled using the MPU.

## Receiver

Incoming RF signals from the antenna connector are delivered to the MAIN Unit, and pass through a low-pass filter (LPF) antenna switching network consisting of coils L1001, L1002, L1003, L1004 and L1005, capacitors C1004, C1008, C1009, C1011, and C1014, and antenna switching diodes D1006, D1007 and D1008 for delivery to the receiver front end.

Signals within the frequency range of the transceiver are then passed through a varactor-tuned bandpass filter consisting of L1009, L10014 before RF amplification by Q1012 (**2SK4227**).

The amplified RF is then band-pass filtered again by varactor-tuned resonators L1022, L1026 to ensure pure in-band input to 1st mixer Q1025 (**2SK228**).

Buffered output from the VCO Unit is amplified by Q1021 (**2SC5107**) and low-pass filtered by L1030 / L1031 and C1178 / C1180 / C1182, to provide a pure 1st local signal between 112.3 and 152.3 MHz to the 1st mixer.

The 43.95 MHz 1st mixer product then passes through dual monolithic crystal filters XF1001 and XF1002 (7.5 kHz BW), and is amplified by Q1029 (**2SC4215Y**) and delivered to the input of the FM IF subsystem IC Q1026 (**TA31136FN**).

This IC contains the 2nd mixer, 2nd local oscillator, limiter amplifier, FM detector, noise amplifier, and squelch gates.

The 2nd LO in the IF-IC is produced from crystal X1001 (14.500 MHz), and the 1st IF is converted to 450 kHz by the 2nd mixer and stripped of unwanted components by ceramic filter CF1001 or CF1002.

After passing through a limiter amplifier, the signal is demodulated by the FM detector.

Demodulated receive audio from the IF-IC is amplified by Q2014 (**CXA1846N**). After volume adjustment by the AF power amplifier Q2029 (**TDA7240AV**), the audio signal is passed to the optional headphone jack or 4-ohm loudspeaker.

## PLL synthesizer

The 1st LO maintains stability from the PLL synthesizer by using a 14.500 MHz reference signal from crystal X1001. PLL synthesizer IC Q1024 (**SA7025DK**) consists of a prescaler, reference counter, swallow counter, programmable counter, a serial data input port to set these counters based on the external data, a phase comparator, and charge pump. The PLL-IC divides the 14.500 MHz reference signal by 725 using the reference counter (20.0 kHz comparison frequency). The phase detector comparison frequency to be eight times the channel spacing (2.5kHz). The VCO output is divided by the prescaler, swallow counter and programmable counter. These two signals are compared by the phase comparator and input to the charge pump. A voltage proportional to their phase difference is delivered to the low-pass filter circuit, then fed back to the VCO as a voltage with phase error, controlling and stabilizing the oscillating frequency. This synthesizer also operates as a modulator during transmit.

The RX-VCO is comprised of Q1015 (**2SK508**) and D1017, D1018 (**1SV276x2**), and oscillates between 356.050 MHz and 468.050 MHz according to the programmed receiving frequency. And the TX-VCO is comprised of Q1014 (**2SC4226**) and D1015, D1016, D1019 (**1SV276x2**, **1SV230**), and oscillates between 400.000MHz and 512.000MHz according to the programmed transmit frequency. The VCO output passes through buffer amplifier Q1018 (**2SC5107**), and a portion is fed to the buffer amplifier Q1019 (**2SC5107**) of the PLL IC, and at the same time amplified by Q1021 (**2SC5107**) to obtain stable output. The VCO DC supply is regulated by Q1008 (**2SC4154E**). Synthesizer output is fed to the 1st mixer by diode switch D1024(**1SS321**) during receive, and to drive amplifier Q1020 (**2SC5107**) / Q1022 (**2SC5415E**) / Q1031 (**2SC2954**) for transmit. The reference oscillator feeds the PLL synthesizer, and is composed of crystal X1001 (14.500 MHz), the temperature compensation circuit which includes D1033 (**MC2850**) and thermostats TH1003 and TH1002, and transmit (DCS) modulation circuit D1029 (**1SV230**).

# ***Circuit Description***

## ***Transmitter***

Voice audio from the microphone is delivered via the Mic (Jack) Unit to the MAIN Unit, after passing through amplifier Q3039/Q2108 (**NJM2902V**), pre-emphasis, limiter (IDC instantaneous deviation control), and LPF Q2001 (**NJM2902V**), is adjusted for optimum deviation level and delivered to the next stage.

Voice input from the microphone and CTCSS are FM-modulated to the VCO of the synthesizer, while DCS audio is modulated by the reference frequency oscillator of the synthesizer.

Synthesizer output, after passing through diode switch D1024 (**1SS321**), is amplified by driver Q1020 (**2SC5107**) / Q1022 (**2SC5415E**) / Q1031 (**2SC2954**) and power module Q1013 (**M68759**) to obtain full RF output.

The RF energy then passes through antenna switch D1007 / D1008 and a low-pass filter circuit and finally to the antenna connector.

RF output power from the final amplifier is sampled by CM coupler and is rectified by D1011, D1014 (**HSM88ASx2**). The resulting DC is fed through Automatic Power Controller Q1007 (**NJM2904V**), Q1001 (**2SC4154E**), Q1002 (**2SB1143S**) to transmitter RF amplifier and thus the power output.

Generation of spurious products by the transmitter is minimized by the fundamental carrier frequency being equal to the final transmitting frequency, modulated directly in the transmit VCO. Additional harmonic suppression is provided by a low-pass filter consisting of L1001, L1003, L1004 and C1004, C1008, C1009, C1011 and C1014, resulting in more than 60dB of harmonic suppression prior to delivery to the RF energy to the antenna.

## ***DCS Demodulator***

DCS signals are demodulated on the MAIN-UNIT, and are applied to low-pass filter Q2110 (**NJM2902V**), as well as the limiter comparator Q2110.

## ***CTCSS encoder/decoder***

The CTCSS code is generation and encoding by MPU IC Q2019 (**MB90F583B**).

Demodulation and detection of the CTCSS tones are carried out by IC Q2013 (**MX165C**).

## ***MPU***

Operation is controlled by 16-bit MPU IC Q2019 (**MB90F583B**). The system clock uses a 16.000 MHz crystal for a time base. IC Q2027 (**S-80735SN**) resets the MPU when the power is on, and monitors the voltage of the regulated 5V power supply line.

## ***EEPROM***

The EEPROM retains TX and RX data for all memory channels and CTCSS data, DCS data, prescaler dividing, and REF oscillator data (internal/external).

The VX-4000 has been carefully aligned at the factory for the specified performance across the frequency range specified for each version.

Realignment should therefore not be necessary except in the event of a component failure, or alteration of version. All component replacement and service should be performed only by an authorized **VERTEX STANDARD** representative, or the warranty policy may be voided.

The following procedures cover the sometimes critical and tedious adjustments that are not normally required once the transceiver has left the factory. However, if damage occurs and some parts are replaced, realignment may be required. If a sudden problem occurs during normal operation, it is likely due to component failure; realignment should not be done until after the faulty component has been replaced.

We recommend that servicing be performed only by authorized **VERTEX STANDARD** service technicians who are experienced with the circuitry and fully equipped for repair and alignment. Therefore, if a fault is suspected, contact the dealer from whom the transceiver was purchased for instructions regarding repair.

Authorized **VERTEX STANDARD** service technicians realign all circuits and make complete performance checks to ensure compliance with factory specifications after replacing any faulty components. Those who do undertake any of the following alignments are cautioned to proceed at their own risk. Problems caused by unauthorized attempts at realignment are not covered by the warranty policy. Also, **VERTEX STANDARD** must reserve the right to change circuits and alignment procedures in the interest of improved performance, without notifying owners. Under no circumstances should any alignment be attempted unless the normal function and operation of the transceiver are clearly understood, the cause of the malfunction has been clearly pinpointed and any faulty components replaced, and the need for realignment determined to be absolutely necessary. The following test equipment (and thorough familiarity with its correct use) is necessary for complete realignment. Correction of problems caused by misalignment resulting from use of improper test equipment is not covered under the warranty policy.

While most steps do not require all of the equipment listed, the interactions of some adjustments may require that more complex adjustments be performed afterwards.

Do not attempt to perform only a single step unless it is clearly isolated electrically from all other steps. Have all test equipment ready before beginning, and follow all of the steps in a section in the order presented.

## **Required Test Equipment**

- RF signal generator: calibrated output level at 1000 MHz
- Deviation Meter (linear detector)
- AF Millivoltmeter
- SINAD Meter
- Inline Wattmeter with 5% accuracy at 1000 MHz
- Regulated DC Power Supply: adjustable from 10 to 17 VDC, 15A
- 50-ohm Non-reactive Dummy Load: 100 W at 1000 MHz
- Frequency Counter: >0.1 ppm accuracy at 1000 MHz
- AF Signal Generator
- DC Voltmeter: high impedance
- RF Sampling Coupler(attenuation pad)
- AF Dummy Load: 4 ohm, 20W
- Oscilloscope
- Spectrum Analyzer
- IBM PC/compatible computer w/ VERTEX STANDARD CT-71 programming cable and CE-35 channel programming editor.

## **Alignment Preparation & Precautions**

A dummy load and inline wattmeter must be connected to the main antenna jack in all procedures that call for transmission, except where specified otherwise. Correct alignment is not possible with an antenna. After completing one step, read the following step to determine whether the same test equipment will be required. If not, remove the test equipment (except dummy load and wattmeter, if connected) before proceeding.

Correct alignment requires that the ambient temperature be the same as that of the transceiver and test equipment, and that this temperature be held constant between 20 and 30°C (68 ~ 86°F). When the transceiver is brought into the shop from hot or cold air it should be allowed some time for thermal equalization with the environment before alignment. If possible, alignments should be made with oscillator shields and circuit boards firmly affixed in place. Also, the test equipment must be thoroughly warmed up before beginning.

# Alignment

Before beginning, connect the transceiver and PC using the CT-71 programming cable as described in the EEPROM Programming chapter, and download the EEPROM data from the transceiver to the computer.

Store this data in a disk file so that it can be saved and retrieved later. Using the table below, program the channel, CTCSS, and DCS alignment settings for your transceiver version. Upload this file to the transceiver.

**Note:** Signal levels in dB referred to in this procedure are based on 0 dB $\mu$  = 0.5  $\mu$ V (closed circuit).

**Caution:** Do not connect this line to ground, and be certain that the speaker has adequate capability to handle the audio output from the radio.

Because of the bridge audio amplifier circuit used in the radio, it is necessary to construct and use a simple audio load test adapter as shown in the schematic diagram above, when conducting receiver alignment steps.

## Alignment Channel Frequencies

### UHF TYPE A

Channel	Frequency (simplex)	CTCSS Encode	DCS Encode	Narrow/wide
CH1	400.01 MHz	None	None	Wide
CH2	415.01 MHz	None	None	Wide
CH3	429.99 MHz	None	None	Wide
CH4	400.01 MHz	None	None	Narrow
CH5	415.01 MHz	None	None	Narrow
CH6	429.99 MHz	None	None	Narrow
CH7	415.01 MHz	151.4 Hz	None	Wide
CH8	415.01 MHz	None	023	Wide
CH9	415.01 MHz	151.4 Hz	None	Narrow
CH10	415.01 MHz	None	023	Narrow

### UHF TYPE D

Channel	Frequency (simplex)	CTCSS Encode	DCS Encode	Narrow/wide
CH1	450.01 MHz	None	None	Wide
CH2	465.01MHz	None	None	Wide
CH3	479.99 MHz	None	None	Wide
CH4	450.01 MHz	None	None	Narrow
CH5	465.01 MHz	None	None	Narrow
CH6	479.99 MHz	None	None	Narrow
CH7	465.01 MHz	151.4 Hz	None	Wide
CH8	465.01 MHz	None	023	Wide
CH9	465.01 MHz	151.4 Hz	None	Narrow
CH10	465.01 MHz	None	023	Narrow

### UHF TYPE F

Channel	Frequency (simplex)	CTCSS Encode	DCS Encode	Narrow/wide
CH1	480.01 MHz	None	None	Wide
CH2	496.01 MHz	None	None	Wide
CH3	511.99 MHz	None	None	Wide
CH4	480.01 MHz	None	None	Narrow
CH5	496.01 MHz	None	None	Narrow
CH6	511.99 MHz	None	None	Narrow
CH7	496.01 MHz	151.4 Hz	None	Wide
CH8	496.01 MHz	None	023	Wide
CH9	496.01 MHz	151.4 Hz	None	Narrow
CH10	496.01 MHz	None	023	Narrow

### PLL & Transmitter

Set up the test equipment as shown for transmitter alignment.

Maintain the supply voltage at 13.8 V DC for all steps.

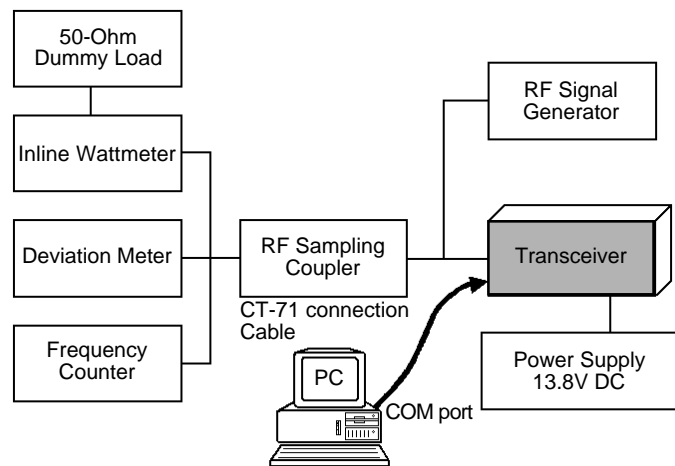

### PLL VCV

- Connect the positive lead of the DC voltmeter to the test point **TP1007** (VCV) on the Main Unit, as indicated in the figure, and the negative lead to chassis ground.
- Set the transceiver to the high band edge frequency channel, then adjust **L1016** on the Unit for 4.2 V on the voltmeter.
- Key the transmitter, and adjust **L1017** on the Unit for 4.2 V on the voltmeter.
- Next select to the low edge frequency channel and confirm 1.0 V on the voltmeter.
- Key the transmitter, and confirm 1.0 V on the voltmeter.

### PLL Reference Frequency

With the wattmeter, dummy load and frequency counter connected to the antenna jack, and select band center frequency channel, key the transmitter (Low power level) and adjust **TC1001** on the Main Unit, if necessary, so the counter frequency is with-



in 100 Hz of the channel center frequency for the transceiver version.

## Transmitter Output Power

The following transmitter parameters can be adjusted from the computer by utilizing the Alignment Software. Refer to the onboard help of the Alignment Software Manual for details.

- HIGH Power**     $50 \pm 1 \text{ W}$
- LOW Power**     $25 \pm 0.5 \text{ W}$

## Transmitter Deviation

The following modulation parameters can be adjusted from the computer by utilizing the Alignment Software. Refer to the onboard help of the Alignment Software Manual for details.

## Microphone Audio Modulation Level

$4.3 \text{ kHz} \pm 0.1 \text{ kHz}$

## CTCSS Modulation Level

$0.75 \text{ kHz} \pm 0.1 \text{ kHz}$

## DCS Modulation Level

$0.75 \text{ kHz} \pm 0.1 \text{ kHz}$

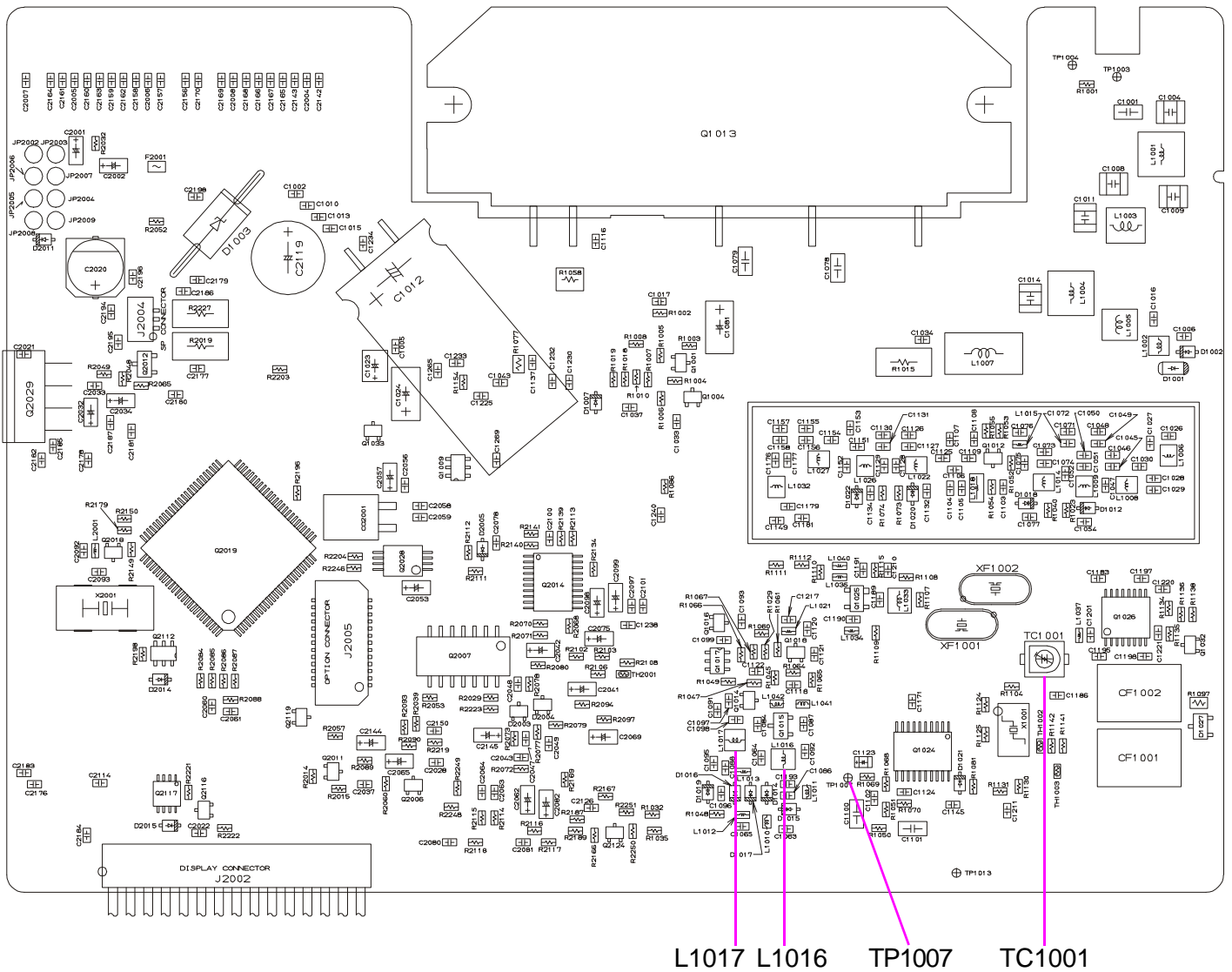

# ***Alignment***

***Note:***

Circuit Diagram

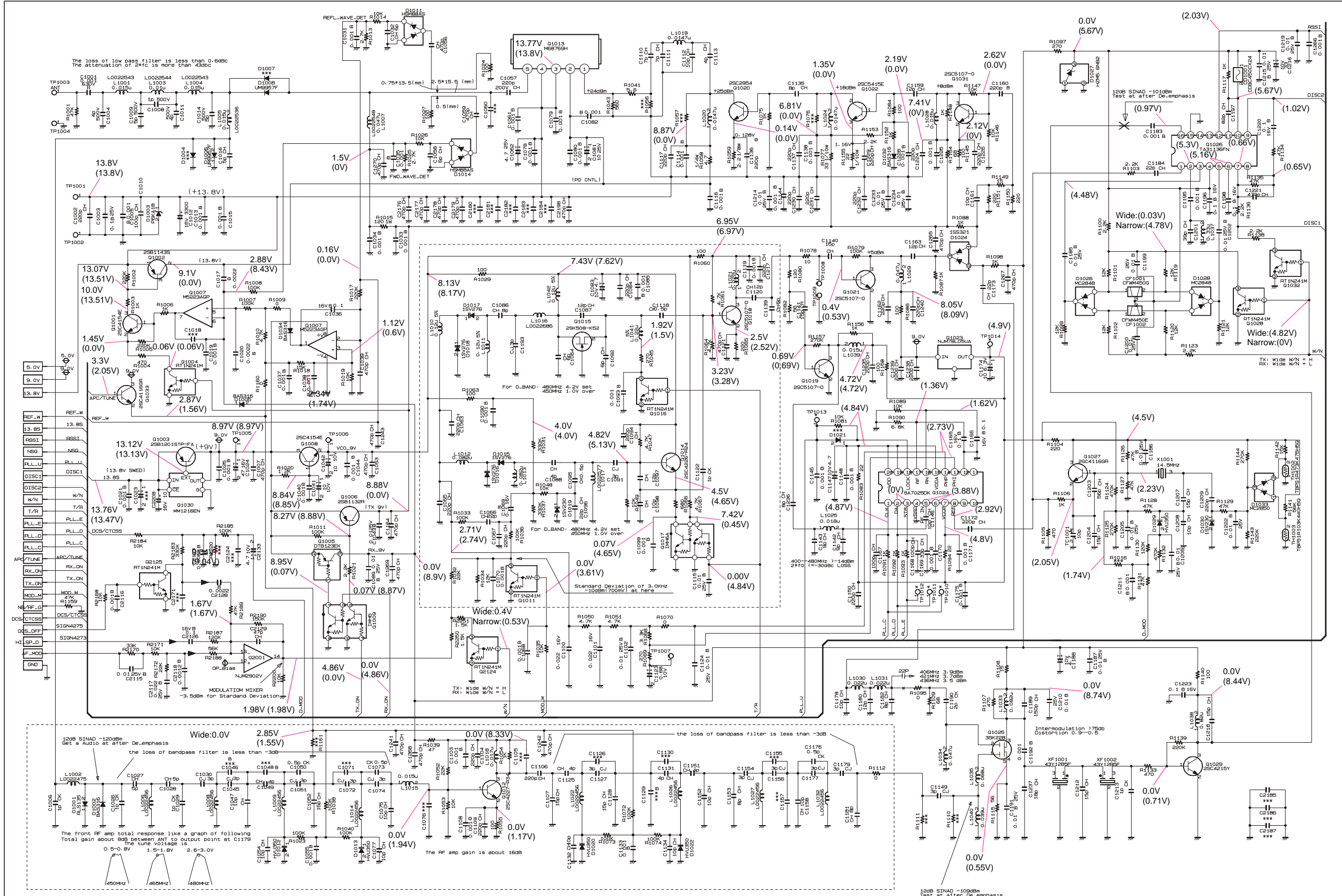

Freq_Band	R19-Vol1um	C1064	C1096	C1087	C1096	C1112	C1113	C1135	C1193	C3066	C1014	C1011	C1009	C1004	C1008	L1003	L1001	L1016	L1017	L1012	G1013
A_BAND 400MHz - 430MHz	7p	7p	15p	10p	15p	12p	7p	12p	3p	22p	22p	8p	8p	8p	8p	10p	L002543	L002543	L002543	L1950528	M6B769L
D_BAND 450MHz - 480MHz	8p	8p	12p	8p	10p	10p	4p	8p	3p	22p	22p	8p	8p	8p	8p	10p	L002544	L002544	L002577	C1085U	M6B769H
F_BAND 480MHz - 512MHz	5p	5p	12p	7p	10p	10p	4p	8p	8p	8p	8p	8p	8p	8p	8p	10p	L002544	L002544	L002456	C1085U	M6B769H

XX: TX 465.00 MHz, MIC Input Level 1 kHz 3.0mV (STD Dev), High Power  
 (XX):RX 465.10 MHz, RF Input Level 40dbm emf (MOD=1.0 kHz, Dev=3.0 kHz), EXT SP OUT 10% Distn 14.0W

# MAIN Unit (Lot. 1~)

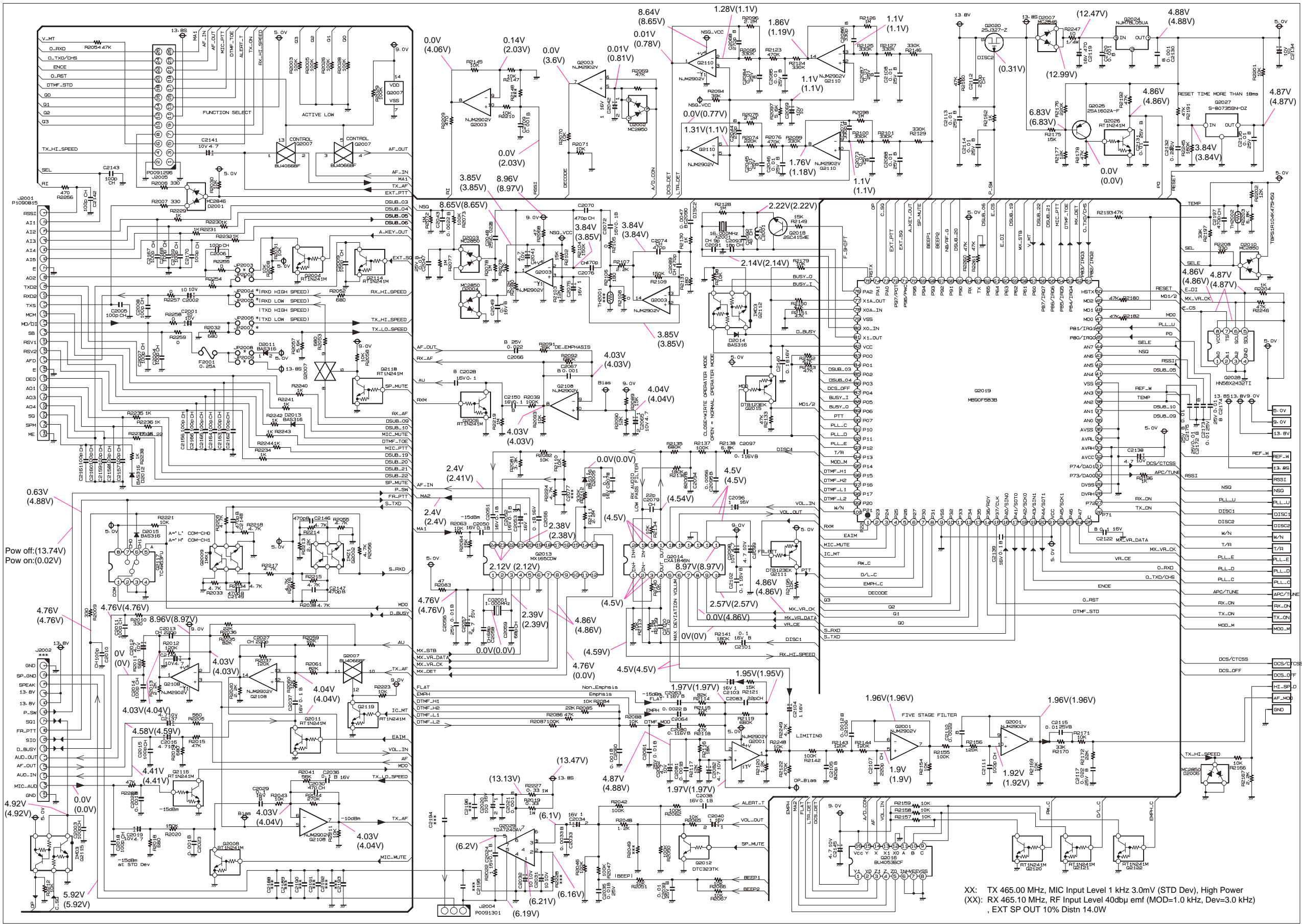

Parts Layout

MAIN Unit (Lot. 1~)

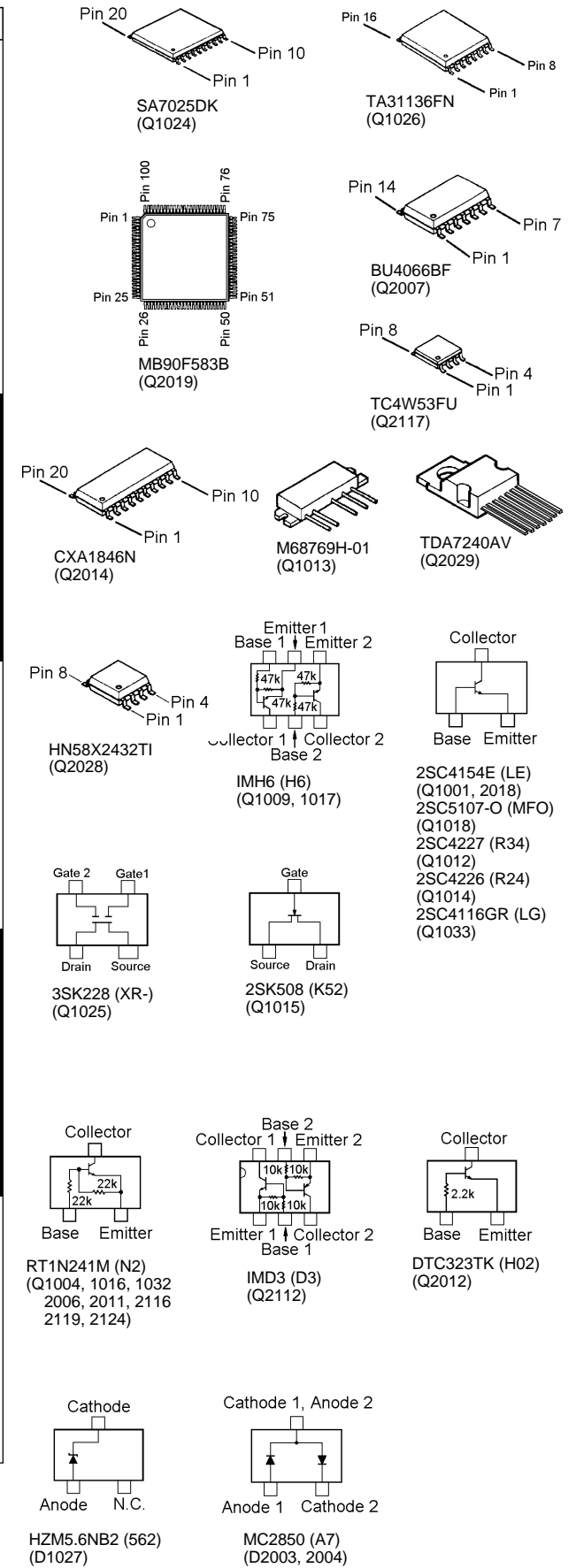
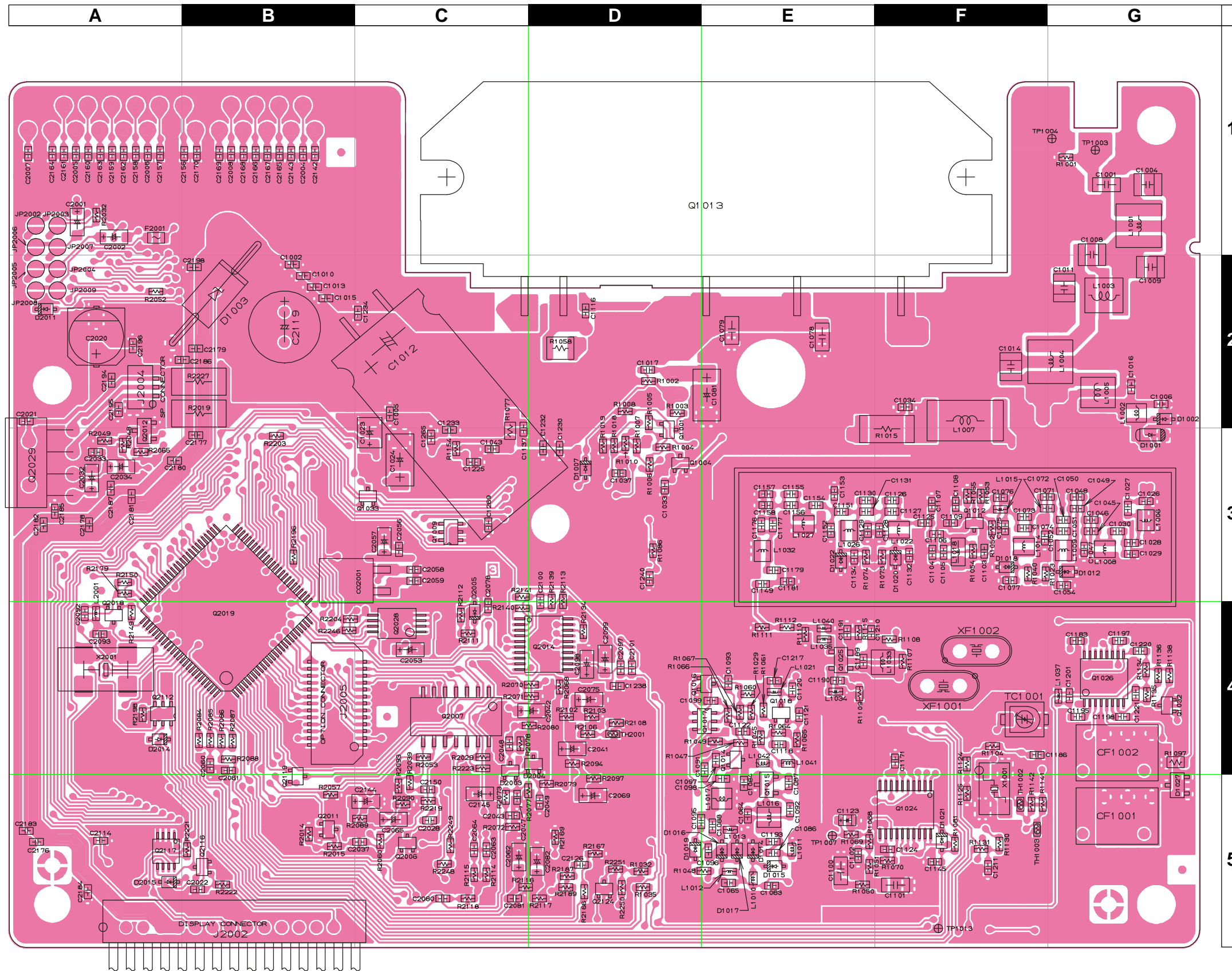

Side A

# MAIN Unit (Lot. 1~)

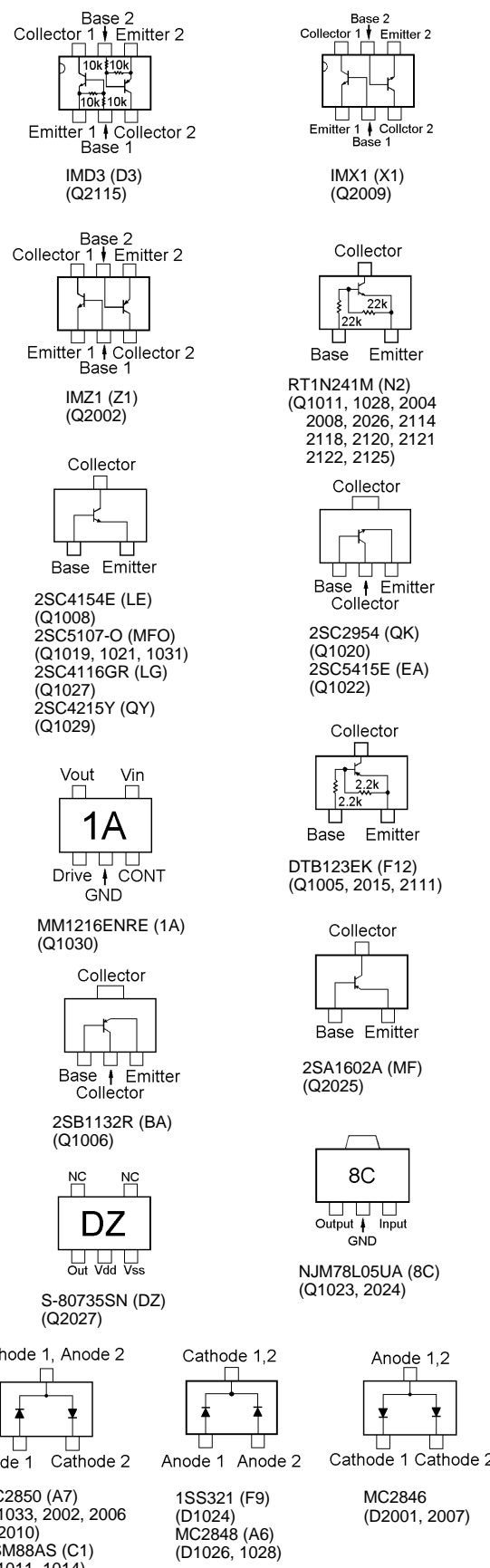
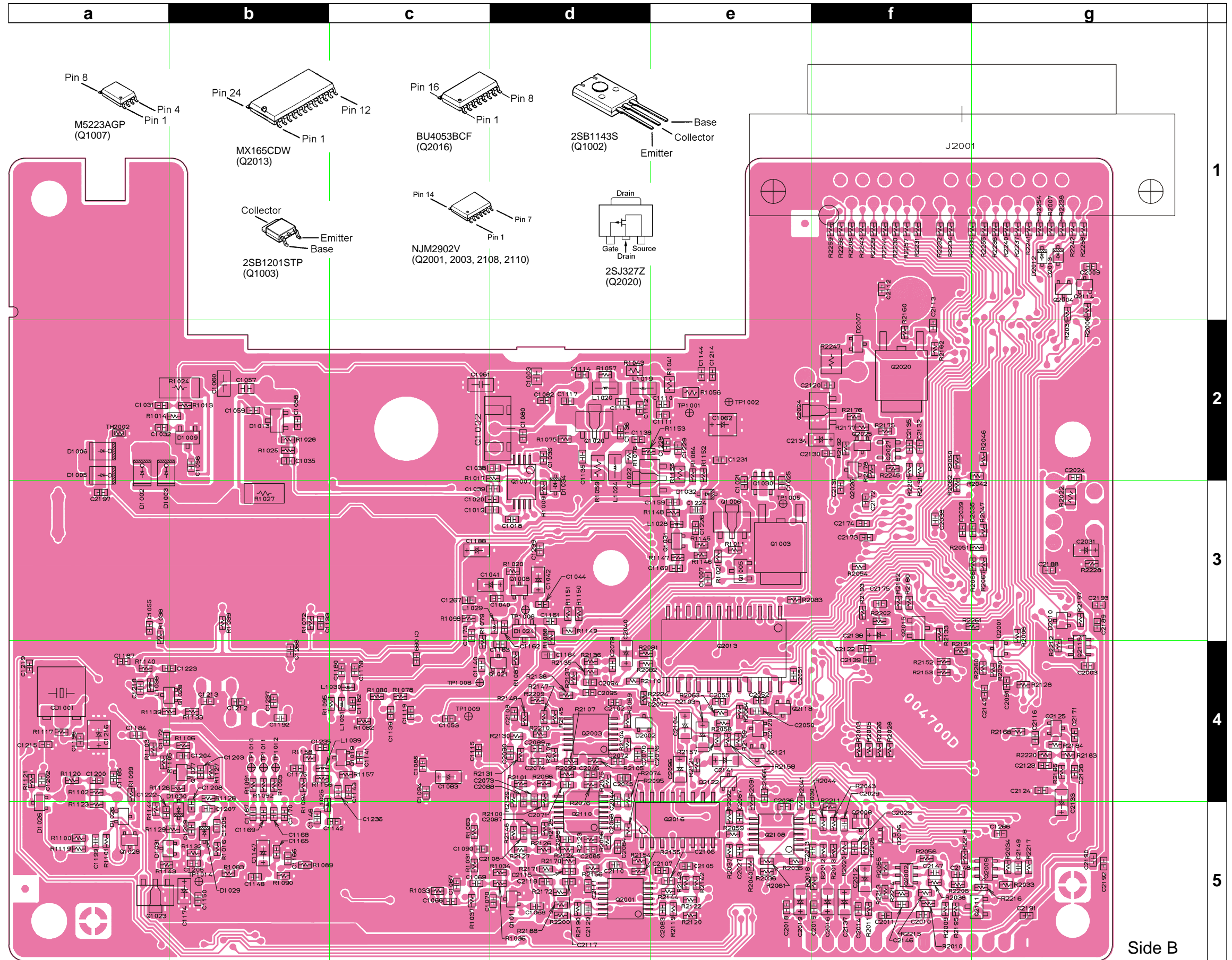



# MAIN Unit (Lot. 4~)

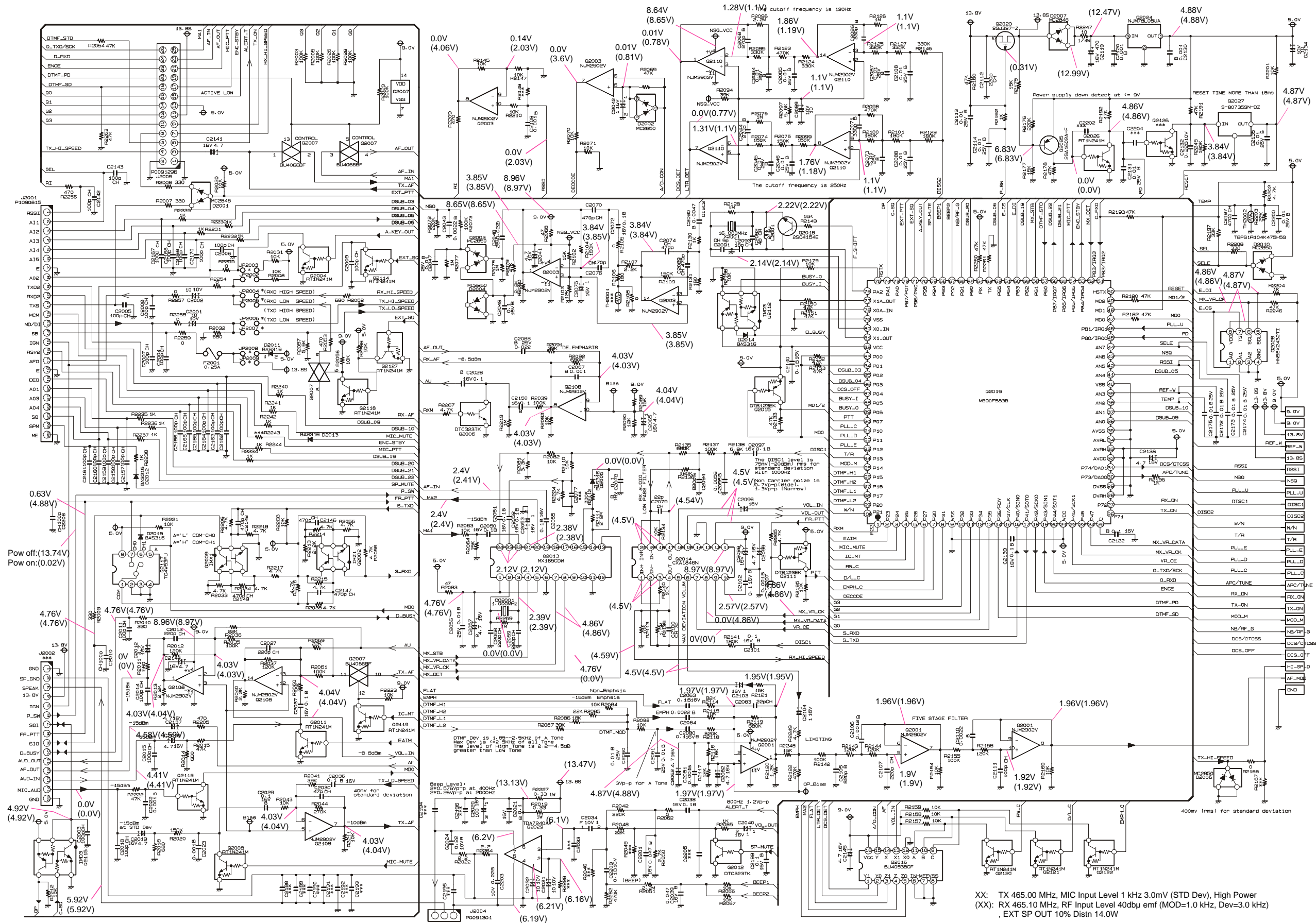

XX: TX 465.00 MHz, MIC Input Level 1 kHz 3.0mV (STD Dev), High Power  
 (XX): RX 465.10 MHz, RF Input Level 40dbm emf (MOD=1.0 kHz, Dev=3.0 kHz)  
 , EXT SP OUT 10% Distn 14.0W



## Parts Layout

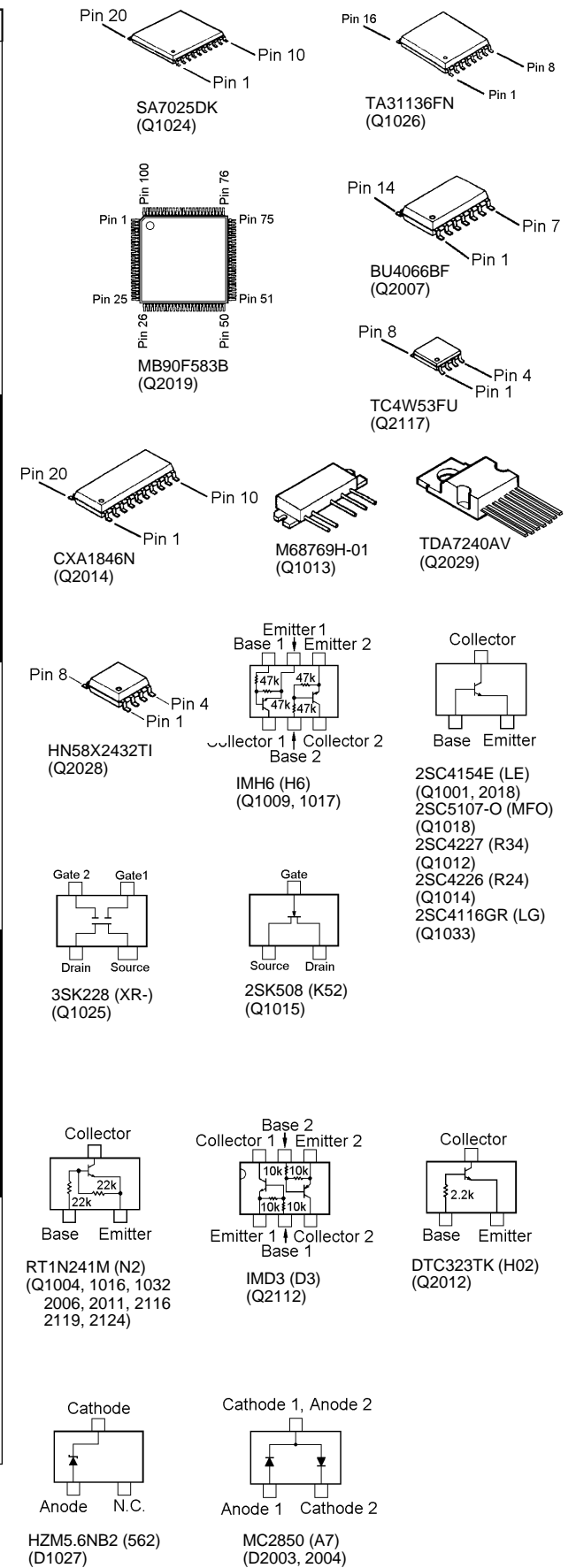
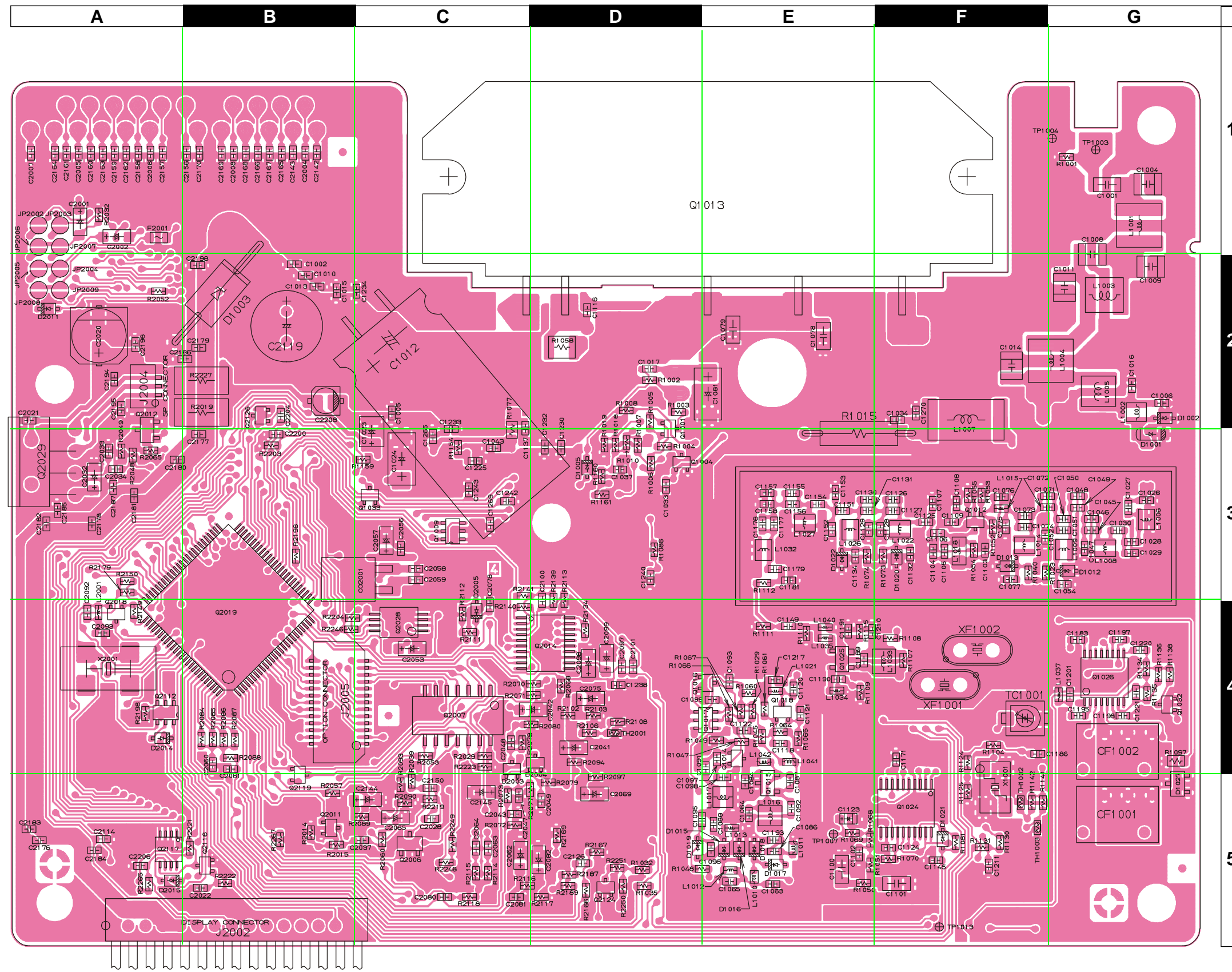

Side A

# MAIN Unit (Lot. 4~)

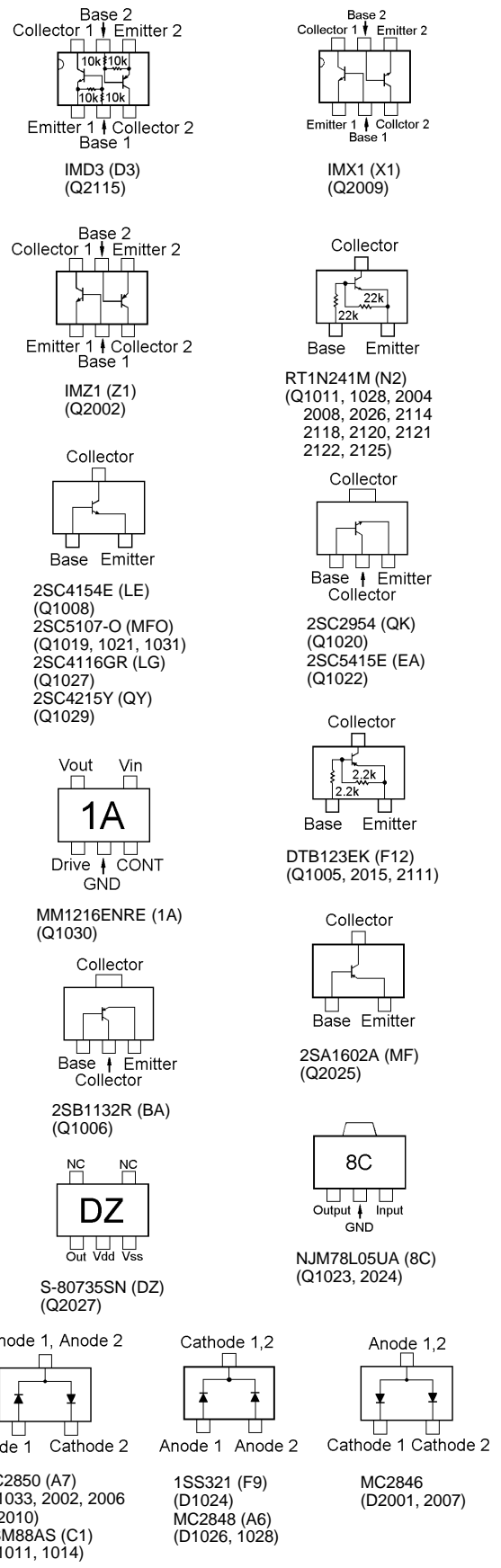
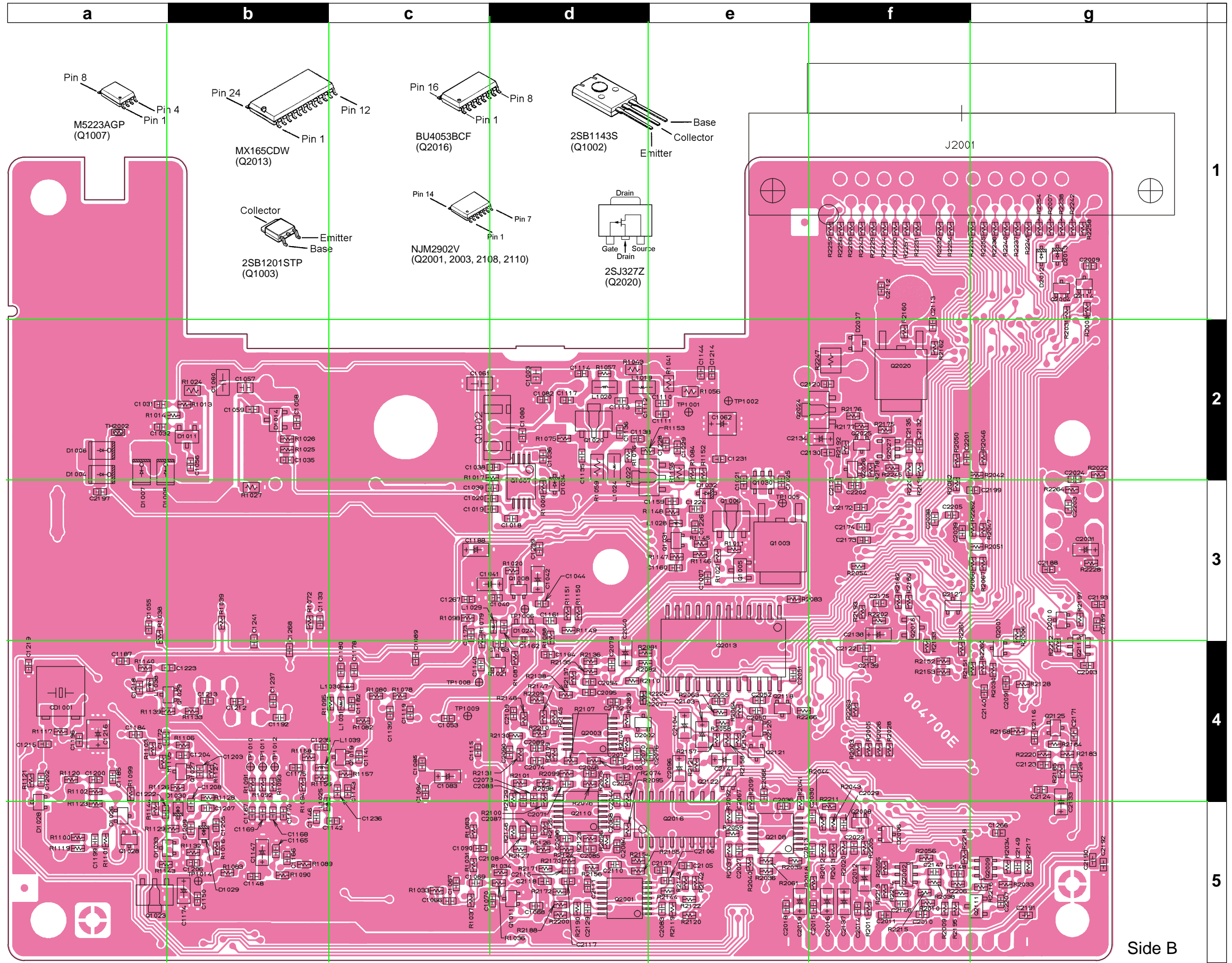

## Parts List

REF.	DESCRIPTION	VALUE	WV	TOL.	MFR'S DESIG	VXSTD P/N	VERS.	LOT.	SIDE.	LAY.ADR.
*** MAIN UNIT ***										
	PCB with Components					CS1729001	VERSION D			
	PCB with Components					CS1729002	VERSION F			
	PCB with Components					CS1729003	VERSION A			
	Printed Circuit Board					FR004700D		1-		
	Printed Circuit Board					FR004700E		4-		
C 1001	CHIP CAP.	0.001uF	630V	R	GHM1030R102K630PT	K22281801		1-	A	G1
C 1002	CHIP CAP.	220pF	50V	CH	GRM39CH221J50PT	K22174243		1-	A	B2
C 1003	CHIP CAP.	0.1uF	25V	B	GRM40B104M25PT	K22140811		1-	B	d2
C 1004	FILM CAP.	4pF	500V		UC232H0040D-T	K33279044		1-2	A	G1
C 1004	FILM CAP.	3pF	500V		UC232H0030D-T	K33279027	VERSION A	3-	A	G1
C 1004	FILM CAP.	4pF	500V		UC232H0040D-T	K33279044	VERSION D	3-	A	G1
C 1004	FILM CAP.	2pF	500V		UC232H0020D-T	K33279043	VERSION F	4-	A	G1
C 1005	CHIP CAP.	0.001uF	50V	B	GRM39B102K50PT	K22174821		1-	A	C2
C 1006	CHIP CAP.	1pF	50V	CK	GRM39CK010C50PT	K22174202		1-	A	G2
C 1007	CHIP CAP.	470pF	50V	CH	GRM39CH471J50PT	K22174249		1-	B	e3
C 1008	FILM CAP.	1pF	500V		UC232H0010D-T	K33279036		1-2	A	G1
C 1008	FILM CAP.	1pF	500V		UC232H0010D-T	K33279036	VERSION A	3-	A	G1
C 1008	FILM CAP.	1pF	500V		UC232H0010D-T	K33279036	VERSION D	3-	A	G1
C 1008	FILM CAP.	2pF	500V		UC232H0020D-T	K33279043	VERSION F	4-	A	G1
C 1009	FILM CAP.	5pF	500V		UC232H0050D-T	K33279010		1-2	A	G2
C 1009	FILM CAP.	6pF	500V		UC232H0060D-T	K33279045	VERSION A	3-	A	G2
C 1009	FILM CAP.	5pF	500V		UC232H0050D-T	K33279010	VERSION D	3-	A	G2
C 1009	FILM CAP.	5pF	500V		UC232H0050D-T	K33279010	VERSION F	4-	A	G2
C 1010	CHIP CAP.	100pF	50V	CH	GRM39CH101J50PT	K22174235		1-	A	B2
C 1011	FILM CAP.	4pF	500V		UC232H0040D-T	K33279044		1-2	A	G2
C 1011	FILM CAP.	5pF	500V		UC232H0050D-T	K33279010	VERSION A	3-	A	G2
C 1011	FILM CAP.	4pF	500V		UC232H0040D-T	K33279044	VERSION D	3-	A	G2
C 1011	FILM CAP.	5pF	500V		UC232H0050D-T	K33279010	VERSION F	4-	A	G2
C 1012	AL.ELECTRO.CAP.	3300uF	16V		RE3-16V332M 3300UF	K40129065		1-	A	C2
C 1013	CHIP CAP.	0.001uF	50V	B	GRM39B102K50PT	K22174821		1-	A	B2
C 1014	FILM CAP.	5pF	500V		UC232H0050D-T	K33279010		1-2	A	F2
C 1014	FILM CAP.	5pF	500V		UC232H0050D-T	K33279010	VERSION A	3-	A	F2
C 1014	FILM CAP.	5pF	500V		UC232H0050D-T	K33279010	VERSION D	3-	A	F2
C 1014	FILM CAP.	4pF	500V		UC232H0040D-T	K33279044	VERSION F	4-	A	F2
C 1015	CHIP CAP.	0.001uF	50V	B	GRM39B102K50PT	K22174821		1-	A	B2
C 1016	CHIP CAP.	5pF	50V	CH	GRM39CH050C50PT	K22174206		1-	A	G2
C 1017	CHIP CAP.	0.0022uF	50V	B	GRM39B222M50PT	K22174813		1-	A	D2
C 1017	CHIP CAP.	0.0022uF	50V	B	GRM39B222K50PT	K22174822		4-	A	D2
C 1019	CHIP CAP.	0.001uF	50V	B	GRM39B102K50PT	K22174821		1-	B	d3
C 1020	CHIP CAP.	0.0022uF	50V	B	GRM39B222M50PT	K22174813		1-	B	d3
C 1020	CHIP CAP.	0.0022uF	50V	B	GRM39B222K50PT	K22174822		4-	B	d3
C 1021	CHIP CAP.	0.001uF	50V	B	GRM39B102K50PT	K22174821		1-	B	e3
C 1023	CHIP TA.CAP.	10uF	16V		TEMSVB21C106M-8R	K78120025		1-	A	C3
C 1023	CHIP TA.CAP.	4.7uF	25V		TEMSVB21E475M-8R	K78140019		3	A	C3
C 1024	CHIP TA.CAP.	68uF	10V		TEMSVC1A686M12R	K78100048		1-	A	C3
C 1024	CHIP TA.CAP.	47uF	16V		TEMSVC1C476M12R	K78120057		4-	A	C3
C 1025	CHIP CAP.	0.001uF	50V	B	GRM39B102K50PT	K22174821		1-	B	e3
C 1026	CHIP CAP.	1pF	50V	CK	GRM39CK010C50PT	K22174202		1-	A	G3
C 1027	CHIP CAP.	5pF	50V	CH	GRM39CH050C50PT	K22174206		1-	A	G3
C 1028	CHIP CAP.	5pF	50V	CH	GRM39CH050C50PT	K22174206		1-2	A	G3
C 1028	CHIP CAP.	5pF	50V	CH	GRM39CH050C50PT	K22174206	VERSION A	3-	A	G3
C 1028	CHIP CAP.	5pF	50V	CH	GRM39CH050C50PT	K22174206	VERSION D	3-	A	G3
C 1028	CHIP CAP.	4pF	50V	CH	GRM39CH040C50PT	K22174205	VERSION F	4-	A	G3
C 1029	CHIP CAP.	1pF	50V	CK	GRM39CK010C50PT	K22174202		1-2	A	G3
C 1029	CHIP CAP.	4pF	50V	CH	GRM39CH040C50PT	K22174205	VERSION A	3-	A	G3
C 1029	CHIP CAP.	1pF	50V	CK	GRM39CK010C50PT	K22174202	VERSION D	3-	A	G3
C 1030	CHIP CAP.	3pF	50V	CJ	GRM39CJ030C50PT	K22174204		1-2	A	G3
C 1030	CHIP CAP.	5pF	50V	CH	GRM39CH050C50PT	K22174206	VERSION A	3-	A	G3
C 1030	CHIP CAP.	3pF	50V	CJ	GRM39CJ030C50PT	K22174204	VERSION D	3-	A	G3

# MAIN Unit

REF.	DESCRIPTION	VALUE	WV	TOL.	MFR'S DESIG	VXSTD P/N	VERS.	LOT.	SIDE	LAY ADR.
C 1030	CHIP CAP.	3pF	50V	CJ	GRM39CJ030C50PT	K22174204	VERSION F	4-	A	G3
C 1031	CHIP CAP.	0.001uF	50V	B	GRM39B102K50PT	K22174821		1-	B	a2
C 1032	CHIP CAP.	6pF	50V	CH	GRM39CH060D50PT	K22174207		1-	B	a2
C 1033	CHIP CAP.	0.001uF	50V	B	GRM39B102K50PT	K22174821		1-	A	D3
C 1034	CHIP CAP.	0.001uF	50V	B	GRM39B102K50PT	K22174821		1-	A	F2
C 1035	CHIP CAP.	0.001uF	50V	B	GRM39B102K50PT	K22174821		1-	B	b2
C 1036	CHIP CAP.	0.1uF	16V	B	GRM39B104K16PT	K22124805		1-	B	d2
C 1037	CHIP CAP.	0.001uF	50V	B	GRM39B102K50PT	K22174821		1-	A	D3
C 1038	CHIP CAP.	0.001uF	50V	B	GRM39B102K50PT	K22174821		1-	B	d2
C 1039	CHIP CAP.	470pF	50V	CH	GRM39CH471J50PT	K22174249		1-	B	d3
C 1040	CHIP CAP.	0.001uF	50V	B	GRM39B102K50PT	K22174821		1-	B	d3
C 1041	CHIP TA.CAP.	10uF	10V		TEMSVA1A106M-8R	K78100028		1-	B	d3
C 1042	CHIP TA.CAP.	10uF	10V		TEMSVA1A106M-8R	K78100028		1-	B	d3
C 1043	CHIP CAP.	0.01uF	25V	B	GRM39B103K25PT	K22144803		1-	A	C3
C 1044	CHIP CAP.	0.001uF	50V	B	GRM39B102K50PT	K22174821		1-	B	d3
C 1045	CHIP CAP.	3pF	50V	CJ	GRM39CJ030C50PT	K22174204		1-	A	G3
C 1047	CHIP CAP.	10pF	50V	CH	GRM39CH100D50PT	K22174211		1-	A	G3
C 1048	CHIP CAP.	0.5pF	50V	CK	GRM39CK0R5C50PT	K22174201	VERSION F	4-	A	G3
C 1049	CHIP CAP.	4pF	50V	CH	GRM39CH040C50PT	K22174205		1-	A	G3
C 1050	CHIP CAP.	0.5pF	50V	CK	GRM39CK0R5C50PT	K22174201		1-	A	G3
C 1051	CHIP CAP.	3pF	50V	CJ	GRM39CJ030C50PT	K22174204		1-	A	G3
C 1052	CHIP CAP.	15pF	50V	CH	GRM39CH150J50PT	K22174215		1-	A	F3
C 1053	CHIP CAP.	470pF	50V	CH	GRM39CH471J50PT	K22174249		1-	B	c4
C 1054	CHIP CAP.	10pF	50V	CH	GRM39CH100D50PT	K22174211		1-	A	G3
C 1055	CHIP CAP.	0.001uF	50V	B	GRM39B102K50PT	K22174821		1-	B	a3
C 1056	CHIP CAP.	470pF	50V	CH	GRM39CH471J50PT	K22174249		1-	B	b2
C 1057	CHIP CAP.	220pF	200V	CH	GRM40CH221J200PT	K22230232		1-	B	b2
C 1058	CHIP CAP.	6pF	50V	CH	GRM39CH060D50PT	K22174207		1-	B	b2
C 1059	CHIP CAP.	470pF	50V	CH	GRM39CH471J50PT	K22174249		1-	B	b2
C 1061	CHIP CAP.	0.001uF	50V	B	GRM42-6B102M50PT	K22171801		1-	B	c2
C 1062	CHIP TA.CAP.	4.7uF	25V		TEMSVB21E475M-8R	K78140019		1-	B	e2
C 1063	CHIP CAP.	220pF	50V	CH	GRM39CH221J50PT	K22174243		1-	A	E5
C 1064	CHIP CAP.	6pF	50V	CH	GRM39CH060D50PT	K22174207		1-2	A	E5
C 1064	CHIP CAP.	7pF	50V	CH	GRM39CH070D50PT	K22174208	VERSION A	3-	A	E5
C 1064	CHIP CAP.	6pF	50V	CH	GRM39CH060D50PT	K22174207	VERSION D	3-	A	E5
C 1064	CHIP CAP.	5pF	50V	CH	GRM39CH050C50PT	K22174206	VERSION F	4-	A	E5
C 1065	CHIP CAP.	220pF	50V	CH	GRM39CH221J50PT	K22174243		1-	A	E5
C 1066	CHIP CAP.	22pF	50V	CH	GRM39CH220J50PT	K22174219		1-	B	c5
C 1067	CHIP CAP.	220pF	50V	CH	GRM39CH221J50PT	K22174243		1-	B	c5
C 1068	CHIP CAP.	0.001uF	50V	B	GRM39B102K50PT	K22174821		1-	B	d5
C 1069	CHIP CAP.	0.1uF	16V	B	GRM39B104K16PT	K22124805		1-	B	c5
C 1070	CHIP CAP.	0.001uF	50V	B	GRM39B102K50PT	K22174821		1-	B	d5
C 1071	CHIP CAP.	0.5pF	50V	CK	GRM39CK0R5C50PT	K22174201	VERSION F	4-	A	F3
C 1072	CHIP CAP.	3pF	50V	CJ	GRM39CJ030C50PT	K22174204		1-	A	F3
C 1073	CHIP CAP.	0.5pF	50V	CK	GRM39CK0R5C50PT	K22174201		1-	A	F3
C 1074	CHIP CAP.	3pF	50V	CJ	GRM39CJ030C50PT	K22174204		1-	A	F3
C 1075	CHIP CAP.	10pF	50V	CH	GRM39CH100D50PT	K22174211		1-	A	F3
C 1077	CHIP CAP.	10pF	50V	CH	GRM39CH100D50PT	K22174211		1-	A	F3
C 1078	CHIP CAP.	0.001uF	50V	B	GRM42-6B102M50PT	K22171801		1-	A	E2
C 1079	CHIP CAP.	0.001uF	50V	B	GRM42-6B102M50PT	K22171801		1-	A	E2
C 1080	CHIP CAP.	0.001uF	50V	B	GRM39B102K50PT	K22174821		1-	B	d2
C 1081	CHIP TA.CAP.	10uF	25V		TEMSVC1E106M12R	K78140021		1-	A	E2
C 1082	CHIP CAP.	0.001uF	50V	B	GRM39B102K50PT	K22174821		1-	B	d2
C 1083	CHIP TA.CAP.	4.7uF	10V		TEMSVA1A475M-8R	K78100022		1-	B	c4
C 1084	CHIP CAP.	220pF	50V	CH	GRM39CH221J50PT	K22174243		1-	A	E5
C 1085	CHIP CAP.	0.001uF	50V	B	GRM39B102K50PT	K22174821		1-	B	c4
C 1086	CHIP CAP.	8pF	50V	CH	GRM39CH080D50PT	K22174209		1-2	A	E5
C 1086	CHIP CAP.	10pF	50V	CH	GRM39CH100D50PT	K22174211	VERSION A	3-	A	E5
C 1086	CHIP CAP.	8pF	50V	CH	GRM39CH080D50PT	K22174209	VERSION D	3-	A	E5
C 1086	CHIP CAP.	7pF	50V	CH	GRM39CH070D50PT	K22174208	VERSION F	4-	A	E5

REF.	DESCRIPTION	VALUE	WV	TOL.	MFR'S DESIG	VXSTD P/N	VERS.	LOT.	SIDE.	LAY ADR.
C 1087	CHIP CAP.	12pF	50V	CH	GRM39CH120J50PT	K22174213		1-2	A	E5
C 1087	CHIP CAP.	15pF	50V	CH	GRM39CH150J50PT	K22174215	VERSION A	3-	A	E5
C 1087	CHIP CAP.	12pF	50V	CH	GRM39CH120J50PT	K22174213	VERSION D	3-	A	E5
C 1087	CHIP CAP.	12pF	50V	CH	GRM39CH120J50PT	K22174213	VERSION F	4-	A	E5
C 1088	CHIP CAP.	4pF	50V	CH	GRM39CH040C50PT	K22174205		1-	A	E5
C 1089	CHIP CAP.	0.01uF	25V	B	GRM39B103K25PT	K22144803		1-	B	c4
C 1090	CHIP CAP.	0.001uF	50V	B	GRM39B102K50PT	K22174821		1-	B	c5
C 1091	CHIP CAP.	3pF	50V	CJ	GRM39CJ030C50PT	K22174204		1-	A	E4
C 1092	CHIP CAP.	6pF	50V	CH	GRM39CH060D50PT	K22174207		1-2	A	E5
C 1092	CHIP CAP.	7pF	50V	CH	GRM39CH070D50PT	K22174208	VERSION A	3-	A	E5
C 1092	CHIP CAP.	6pF	50V	CH	GRM39CH060D50PT	K22174207	VERSION D	3-	A	E5
C 1092	CHIP CAP.	5pF	50V	CH	GRM39CH050C50PT	K22174206	VERSION F	4-	A	E5
C 1093	CHIP CAP.	0.001uF	50V	B	GRM39B102K50PT	K22174821		1-	A	E4
C 1094	CHIP CAP.	220pF	50V	CH	GRM39CH221J50PT	K22174243		1-	B	c4
C 1095	CHIP CAP.	0.5pF	50V	CK	GRM39CK0R5C50PT	K22174201		1-	A	D5
C 1096	CHIP CAP.	22pF	50V	CH	GRM39CH220J50PT	K22174219		1-2	A	E5
C 1096	CHIP CAP.	27pF	50V	CH	GRM39CH270J50PT	K22174221	VERSION A	3-	A	E5
C 1096	CHIP CAP.	22pF	50V	CH	GRM39CH220J50PT	K22174219	VERSION D	3-	A	E5
C 1096	CHIP CAP.	27pF	50V	CH	GRM39CH270J50PT	K22174221	VERSION F	4-	A	E5
C 1097	CHIP CAP.	12pF	50V	CH	GRM39CH120J50PT	K22174213		1-	A	E4
C 1098	CHIP CAP.	10pF	50V	CH	GRM39CH100D50PT	K22174211		1-2	A	E5
C 1098	CHIP CAP.	15pF	50V	CH	GRM39CH150J50PT	K22174215	VERSION A	3-	A	E5
C 1098	CHIP CAP.	10pF	50V	CH	GRM39CH100D50PT	K22174211	VERSION D	3-	A	E5
C 1098	CHIP CAP.	10pF	50V	CH	GRM39CH100D50PT	K22174211	VERSION F	4-	A	E5
C 1099	CHIP CAP.	0.001uF	50V	B	GRM39B102K50PT	K22174821		1-	A	E4
C 1100	FILM CAP.	0.022uF	16V		ECHU1C223JB5	K57120011		1-	A	E5
C 1101	FILM CAP.	0.022uF	16V		ECHU1C223JB5	K57120011		1-	A	F5
C 1102	CHIP CAP.	0.01uF	25V	B	GRM39B103K25PT	K22144803		1-	A	E5
C 1103	CHIP CAP.	0.001uF	50V	B	GRM39B102K50PT	K22174821		1-	A	F3
C 1104	CHIP CAP.	220pF	50V	CH	GRM39CH221J50PT	K22174243		1-	A	F3
C 1106	CHIP CAP.	220pF	50V	CH	GRM39CH221J50PT	K22174243		1-2	A	F3
C 1106	CHIP CAP.	220pF	50V	CH	GRM39CH221J50PT	K22174243	VERSION A	3-	A	F3
C 1106	CHIP CAP.	220pF	50V	CH	GRM39CH221J50PT	K22174243	VERSION D	3-	A	F3
C 1106	CHIP CAP.	10pF	50V	CH	GRM39CH100C50PT	K22174248	VERSION F	4-	A	F3
C 1107	CHIP CAP.	15pF	50V	CH	GRM39CH150J50PT	K22174215		1-	A	F3
C 1108	CHIP CAP.	0.001uF	50V	B	GRM39B102K50PT	K22174821		1-	A	F3
C 1109	CHIP CAP.	220pF	50V	CH	GRM39CH221J50PT	K22174243		1-	A	F3
C 1110	CHIP CAP.	7pF	50V	CH	GRM39CH070D50PT	K22174208		1-	B	e2
C 1111	CHIP CAP.	7pF	50V	CH	GRM39CH070D50PT	K22174208		1-	B	e2
C 1112	CHIP CAP.	10pF	50V	CH	GRM39CH100D50PT	K22174211		1-2	B	d2
C 1112	CHIP CAP.	12pF	50V	CH	GRM39CH120J50PT	K22174213	VERSION A	3-	B	d2
C 1112	CHIP CAP.	10pF	50V	CH	GRM39CH100D50PT	K22174211	VERSION D	3-	B	d2
C 1112	CHIP CAP.	10pF	50V	CH	GRM39CH100D50PT	K22174211	VERSION F	4-	B	d2
C 1113	CHIP CAP.	4pF	50V	CH	GRM39CH040C50PT	K22174205		1-2	B	d2
C 1113	CHIP CAP.	7pF	50V	CH	GRM39CH070D50PT	K22174208	VERSION A	3-	B	d2
C 1113	CHIP CAP.	4pF	50V	CH	GRM39CH040C50PT	K22174205	VERSION D	3-	B	d2
C 1113	CHIP CAP.	4pF	50V	CH	GRM39CH040C50PT	K22174205	VERSION F	4-	B	d2
C 1114	CHIP CAP.	0.001uF	50V	B	GRM39B102K50PT	K22174821		1-	B	d2
C 1115	CHIP CAP.	0.01uF	25V	B	GRM39B103K25PT	K22144803		1-	B	c4
C 1116	CHIP CAP.	0.001uF	50V	B	GRM39B102K50PT	K22174821		1-	A	D2
C 1117	CHIP CAP.	220pF	50V	CH	GRM39CH221J50PT	K22174243		1-	B	d2
C 1118	CHIP CAP.	0.5pF	50V	CK	GRM39CK0R5C50PT	K22174201		1-	A	E4
C 1119	CHIP CAP.	0.001uF	50V	B	GRM39B102K50PT	K22174821		1-	B	c4
C 1120	CHIP CAP.	12pF	50V	CH	GRM39CH120J50PT	K22174213		1-	A	E4
C 1121	CHIP CAP.	470pF	50V	CH	GRM39CH471J50PT	K22174249		1-	A	E4
C 1122	CHIP CAP.	1pF	50V	CK	GRM39CK010C50PT	K22174202		1-	A	E4
C 1123	CHIP TA.CAP.	0.68uF	10V		TESVSP1A684M-8R	K78100025		1-	A	E5
C 1124	CHIP CAP.	0.01uF	25V	B	GRM39B103K25PT	K22144803		1-	A	F5
C 1125	CHIP CAP.	4pF	50V	CH	GRM39CH040C50PT	K22174205		1-	A	F3
C 1126	CHIP CAP.	0.5pF	50V	CK	GRM39CK0R5C50PT	K22174201	VERSION F	4-	A	F3

# MAIN Unit

REF.	DESCRIPTION	VALUE	WV	TOL.	MFR'S DESIG	VXSTD P/N	VERS.	LOT.	SIDE	LAY ADR.
C 1127	CHIP CAP.	3pF	50V	CJ	GRM39CJ030C50PT	K22174204		1-	A	F3
C 1128	CHIP CAP.	15pF	50V	CH	GRM39CH150J50PT	K22174215		1-	A	F3
C 1131	CHIP CAP.	4pF	50V	CH	GRM39CH040C50PT	K22174205		1-2	A	E3
C 1131	CHIP CAP.	3pF	50V	CJ	GRM39CJ030C50PT	K22174204	VERSION A	3-	A	E3
C 1131	CHIP CAP.	4pF	50V	CH	GRM39CH040C50PT	K22174205	VERSION D	3-	A	E3
C 1131	CHIP CAP.	4pF	50V	CH	GRM39CH040C50PT	K22174205	VERSION F	4-	A	E3
C 1132	CHIP CAP.	10pF	50V	CH	GRM39CH100D50PT	K22174211		1-	A	F3
C 1133	CHIP CAP.	0.001uF	50V	B	GRM39B102K50PT	K22174821		1-	B	b3
C 1134	CHIP CAP.	10pF	50V	CH	GRM39CH100D50PT	K22174211		1-	A	E3
C 1135	CHIP CAP.	8pF	50V	CH	GRM39CH080D50PT	K22174209		1-2	B	d2
C 1135	CHIP CAP.	12pF	50V	CH	GRM39CH120J50PT	K22174213	VERSION A	3-	B	d2
C 1135	CHIP CAP.	8pF	50V	CH	GRM39CH080D50PT	K22174209	VERSION D	3-	B	d2
C 1135	CHIP CAP.	8pF	50V	CH	GRM39CH080D50PT	K22174209	VERSION F	4-	B	d2
C 1136	CHIP CAP.	220pF	50V	B	GRM39B221M50PT	K22174801		1-	B	d2
C 1137	CHIP CAP.	220pF	50V	CH	GRM39CH221J50PT	K22174243		1-	A	C3
C 1138	CHIP CAP.	0.001uF	50V	B	GRM39B102K50PT	K22174821		1-	B	d2
C 1139	CHIP CAP.	6pF	50V	CH	GRM39CH060D50PT	K22174207		1-	B	c4
C 1140	CHIP CAP.	15pF	50V	CH	GRM39CH150J50PT	K22174215		1-	B	c4
C 1141	CHIP CAP.	15pF	50V	CH	GRM39CH150J50PT	K22174215		1-	B	c4
C 1142	CHIP CAP.	9pF	50V	CH	GRM39CH090D50PT	K22174210		1-	B	c5
C 1143	CHIP CAP.	9pF	50V	CH	GRM39CH090D50PT	K22174210		1-	B	c4
C 1144	CHIP CAP.	0.001uF	50V	B	GRM39B102K50PT	K22174821		1-	B	e2
C 1145	CHIP CAP.	0.001uF	50V	B	GRM39B102M50PT	K22174809		1-	A	F5
C 1145	CHIP CAP.	0.001uF	50V	B	GRM39B102K50PT	K22174821		4-	A	F5
C 1146	CHIP CAP.	10pF	50V	CH	GRM39CH100D50PT	K22174211		1-	B	b5
C 1147	CHIP TA.CAP.	4.7uF	10V		TEMSVA1A475M-8R	K78100022		1-	B	b5
C 1148	CHIP CAP.	0.001uF	50V	B	GRM39B102K50PT	K22174821		1-	B	b5
C 1149	CHIP CAP.	3pF	50V	CJ	GRM39CJ030C50PT	K22174204		1-2	A	E4
C 1149	CHIP CAP.	6pF	50V	CH	GRM39CH060D50PT	K22174207	VERSION A	3-	A	E4
C 1149	CHIP CAP.	3pF	50V	CJ	GRM39CJ030C50PT	K22174204	VERSION D	3-	A	E4
C 1149	CHIP CAP.	3pF	50V	CJ	GRM39CJ030C50PT	K22174204	VERSION F	4-	A	E4
C 1150	CHIP CAP.	220pF	50V	CH	GRM39CH221J50PT	K22174243		1-	B	b5
C 1151	CHIP CAP.	4pF	50V	CH	GRM39CH040C50PT	K22174205		1-	A	E3
C 1152	CHIP CAP.	10pF	50V	CH	GRM39CH100D50PT	K22174211		1-	A	E3
C 1153	CHIP CAP.	8pF	50V	CH	GRM39CH080D50PT	K22174209		1-4	A	E3
C 1153	CHIP CAP.	8pF	50V	CH	GRM39CH080D50PT	K22174209	VERSION A	5-	A	E3
C 1153	CHIP CAP.	6pF	50V	CH	GRM39CH060D50PT	K22174207	VERSION D	5-	A	E3
C 1153	CHIP CAP.	8pF	50V	CH	GRM39CH080D50PT	K22174209	VERSION F	5-	A	E3
C 1154	CHIP CAP.	3pF	50V	CJ	GRM39CJ030C50PT	K22174204		1-	A	E3
C 1156	CHIP CAP.	3pF	50V	CJ	GRM39CJ030C50PT	K22174204		1-	A	E3
C 1158	CHIP CAP.	10pF	50V	CH	GRM39CH100D50PT	K22174211		1-2	A	E3
C 1158	CHIP CAP.	7pF	50V	CH	GRM39CH070C50PT	K22174245	VERSION A	3-	A	E3
C 1158	CHIP CAP.	10pF	50V	CH	GRM39CH100D50PT	K22174211	VERSION D	3-	A	E3
C 1158	CHIP CAP.	9pF	50V	CH	GRM39CH090D50PT	K22174210	VERSION D	5-	A	E3
C 1158	CHIP CAP.	10pF	50V	CH	GRM39CH100D50PT	K22174211	VERSION F	4-	A	E3
C 1159	CHIP CAP.	12pF	50V	CH	GRM39CH120J50PT	K22174213		1-	B	e3
C 1160	CHIP CAP.	220pF	50V	B	GRM39B221M50PT	K22174801		1-	B	e3
C 1161	CHIP CAP.	10pF	50V	CH	GRM39CH100D50PT	K22174211		1-	B	d3
C 1162	CHIP CAP.	220pF	50V	CH	GRM39CH221J50PT	K22174243		1-	B	d3
C 1163	CHIP CAP.	12pF	50V	CH	GRM39CH120J50PT	K22174213		1-2	B	d4
C 1163	CHIP CAP.	12pF	50V	CH	GRM39CH120J50PT	K22174213	VERSION A	3-	B	d4
C 1163	CHIP CAP.	12pF	50V	CH	GRM39CH120J50PT	K22174213	VERSION D	3-	B	d4
C 1163	CHIP CAP.	8pF	50V	CH	GRM39CH080D50PT	K22174209	VERSION F	4-	B	d4
C 1164	CHIP CAP.	470pF	50V	CH	GRM39CH471J50PT	K22174249		1-	B	d4
C 1165	CHIP CAP.	0.1uF	16V	B	GRM39B104K16PT	K22124805		1-	B	b5
C 1166	CHIP CAP.	0.1uF	16V	B	GRM39B104K16PT	K22124805		1-	B	b5
C 1167	CHIP CAP.	100pF	50V	CH	GRM39CH101J50PT	K22174235		1-	B	b5
C 1168	CHIP CAP.	100pF	50V	CH	GRM39CH101J50PT	K22174235		1-	B	b5
C 1169	CHIP CAP.	33pF	50V	CH	GRM39CH330J50PT	K22174223		1-	B	b5
C 1170	CHIP CAP.	0.001uF	50V	B	GRM39B102K50PT	K22174821		1-	B	b5

REF.	DESCRIPTION	VALUE	WV	TOL.	MFR'S DESIG	VXSTD P/N	VERS.	LOT.	SIDE.	LAY ADR.
C 1171	CHIP CAP.	0.001uF	50V	B	GRM39B102K50PT	K22174821		1-	A	F4
C 1172	CHIP CAP.	220pF	50V	CH	GRM39CH221J50PT	K22174243		1-	B	a4
C 1173	CHIP CAP.	22pF	50V	CH	GRM39CH220J50PT	K22174219		1-	B	c3
C 1174	CHIP TA.CAP.	10uF	6.3V		TEMSVA0J106M-8R	K78080027		1-	B	b5
C 1175	CHIP CAP.	0.001uF	50V	B	GRM39B102K50PT	K22174821		1-	B	b4
C 1176	CHIP CAP.	0.5pF	50V	CK	GRM39CK0R5C50PT	K22174201		1-	A	E3
C 1177	CHIP CAP.	3pF	50V	CJ	GRM39CJ030C50PT	K22174204		1-	A	E3
C 1178	CHIP CAP.	10pF	50V	CH	GRM39CH100D50PT	K22174211		1-	B	c4
C 1179	CHIP CAP.	3pF	50V	CJ	GRM39CJ030C50PT	K22174204		1-	A	E3
C 1180	CHIP CAP.	12pF	50V	CH	GRM39CH120J50PT	K22174213		1-	B	c4
C 1181	CHIP CAP.	8pF	50V	CH	GRM39CH080D50PT	K22174209		1-4	A	E3
C 1181	CHIP CAP.	8pF	50V	CH	GRM39CH080D50PT	K22174209	VERSION A	5-	A	E3
C 1181	CHIP CAP.	6pF	50V	CH	GRM39CH060D50PT	K22174207	VERSION D	5-	A	E3
C 1181	CHIP CAP.	8pF	50V	CH	GRM39CH080D50PT	K22174209	VERSION F	5-	A	E3
C 1182	CHIP CAP.	8pF	50V	CH	GRM39CH080D50PT	K22174209		1-	B	c4
C 1183	CHIP CAP.	0.001uF	50V	B	GRM39B102K50PT	K22174821		1-	A	G4
C 1184	CHIP CAP.	22pF	50V	CH	GRM39CH220J50PT	K22174219		1-	B	a4
C 1185	CHIP CAP.	0.01uF	25V	B	GRM39B103K25PT	K22144803		1-	B	a4
C 1186	CHIP CAP.	0.01uF	25V	B	GRM39B103K25PT	K22144803		1-	A	F4
C 1187	CHIP CAP.	0.01uF	25V	B	GRM39B103K25PT	K22144803		1-	B	a4
C 1188	CHIP TA.CAP.	4.7uF	10V		TEMSVA1A475M-8R	K78100022		1-	B	c3
C 1189	CHIP CAP.	150pF	50V	CH	GRM39CH151J50PT	K22174239		1-	A	E4
C 1190	CHIP CAP.	2pF	50V	CK	GRM39CK020C50PT	K22174203		1-2	A	E4
C 1190	CHIP CAP.	5pF	50V	CH	GRM39CH050C50PT	K22174206	VERSION A	3-	A	E4
C 1190	CHIP CAP.	2pF	50V	CK	GRM39CK020C50PT	K22174203	VERSION D	3-	A	E4
C 1190	CHIP CAP.	2pF	50V	CK	GRM39CK020C50PT	K22174203	VERSION F	4-	A	E4
C 1191	CHIP CAP.	0.01uF	25V	B	GRM39B103K25PT	K22144803		1-	A	E4
C 1192	CHIP CAP.	0.001uF	50V	B	GRM39B102K50PT	K22174821		1-	B	b4
C 1193	CHIP CAP.	3pF	50V	CJ	GRM39CJ030C50PT	K22174204		1-2	A	E5
C 1193	CHIP CAP.	3pF	50V	CJ	GRM39CJ030C50PT	K22174204	VERSION A	3-	A	E5
C 1193	CHIP CAP.	3pF	50V	CJ	GRM39CJ030C50PT	K22174204	VERSION D	3-	A	E5
C 1193	CHIP CAP.	2pF	50V	CK	GRM39CK020C50PT	K22174203	VERSION F	4-	A	E5
C 1195	CHIP CAP.	0.001uF	50V	B	GRM39B102K50PT	K22174821		1-	A	G4
C 1196	CHIP CAP.	0.1uF	16V	B	GRM39B104K16PT	K22124805		1-	B	a4
C 1197	CHIP CAP.	82pF	50V	CH	GRM39CH820J50PT	K22174233		1-	A	G4
C 1198	CHIP CAP.	0.1uF	16V	B	GRM39B104K16PT	K22124805		1-	A	G4
C 1199	CHIP CAP.	0.01uF	25V	B	GRM39B103K25PT	K22144803		1-	B	a5
C 1200	CHIP CAP.	0.01uF	25V	B	GRM39B103K25PT	K22144803		1-	B	a4
C 1201	CHIP CAP.	39pF	50V	CH	GRM39CH390J50PT	K22174225		1-	A	G4
C 1202	CHIP CAP.	0.01uF	25V	B	GRM39B103K25PT	K22144803		1-	B	a4
C 1203	CHIP CAP.	56pF	50V	CH	GRM39CH560J50PT	K22174229		1-	B	b4
C 1204	CHIP CAP.	15pF	50V	CH	GRM39CH150J50PT	K22174215		1-	B	b4
C 1205	CHIP CAP.	0.01uF	25V	B	GRM39B103K25PT	K22144803		1-	B	b5
C 1206	CHIP CAP.	0.01uF	25V	B	GRM39B103M25PT	K22144802		1-	B	b5
C 1206	CHIP CAP.	0.01uF	25V	B	GRM39B103K25PT	K22144803		4-	B	b5
C 1207	CHIP CAP.	15pF	50V	CH	GRM39CH150J50PT	K22174215		1-	B	b5
C 1208	CHIP CAP.	10pF	50V	CH	GRM39CH100D50PT	K22174211		1-	B	b5
C 1209	CHIP CAP.	220pF	50V	CH	GRM39CH221J50PT	K22174243		1-	B	b5
C 1210	CHIP CAP.	0.01uF	25V	B	GRM39B103K25PT	K22144803		1-	A	E4
C 1211	CHIP CAP.	0.001uF	50V	B	GRM39B102M50PT	K22174809		1-	A	F5
C 1211	CHIP CAP.	0.001uF	50V	B	GRM39B102K50PT	K22174821		4-	A	F5
C 1212	CHIP CAP.	15pF	50V	CH	GRM39CH150J50PT	K22174215		1-	B	b4
C 1213	CHIP CAP.	1pF	50V	CK	GRM39CK010C50PT	K22174202		1-	B	b4
C 1214	CHIP CAP.	0.01uF	25V	B	GRM39B103K25PT	K22144803		1-	B	e2
C 1215	CHIP CAP.	0.01uF	25V	B	GRM39B103K25PT	K22144803		1-	B	a4
C 1216	CHIP TA.CAP.	33uF	10V		TEMSVB21A336M-8R	K78100047		1-	B	a4
C 1217	CHIP CAP.	220pF	50V	CH	GRM39CH221J50PT	K22174243		1-	A	E4
C 1218	CHIP CAP.	15pF	50V	CH	GRM39CH150J50PT	K22174215		1-	B	a4
C 1219	CHIP CAP.	0.01uF	25V	B	GRM39B103K25PT	K22144803		1-	B	a4
C 1220	CHIP CAP.	0.1uF	16V	B	GRM39B104K16PT	K22124805		1-	A	G4

# MAIN Unit

REF.	DESCRIPTION	VALUE	WV	TOL.	MFR'S DESIG	VXSTD P/N	VERS.	LOT.	SIDE	LAY ADR.
C 1221	CHIP CAP.	470pF	50V	CH	GRM39CH471J50PT	K22174249		1-	A	G4
C 1222	CHIP CAP.	0.01uF	25V	B	GRM39B103K25PT	K22144803		1-	B	a5
C 1223	CHIP CAP.	0.1uF	16V	B	GRM39B104K16PT	K22124805		1-	B	a4
C 1224	CHIP CAP.	220pF	50V	CH	GRM39CH221J50PT	K22174243		1-	B	e3
C 1225	CHIP CAP.	0.001uF	50V	B	GRM39B102K50PT	K22174821		1-	A	C3
C 1226	CHIP CAP.	220pF	50V	CH	GRM39CH221J50PT	K22174243		1-	B	e3
C 1228	CHIP CAP.	0.001uF	50V	B	GRM39B102K50PT	K22174821		1-	B	e2
C 1229	CHIP CAP.	220pF	50V	CH	GRM39CH221J50PT	K22174243		1-	B	e2
C 1230	CHIP CAP.	220pF	50V	CH	GRM39CH221J50PT	K22174243		1-	A	D3
C 1231	CHIP CAP.	220pF	50V	CH	GRM39CH221J50PT	K22174243		1-	B	e2
C 1232	CHIP CAP.	220pF	50V	CH	GRM39CH221J50PT	K22174243		1-	A	D3
C 1233	CHIP CAP.	0.01uF	25V	B	GRM39B103K25PT	K22144803		1-	A	C3
C 1234	CHIP CAP.	0.01uF	25V	B	GRM39B103K25PT	K22144803		1-	A	B2
C 1235	CHIP CAP.	220pF	50V	CH	GRM39CH221J50PT	K22174243		1-	B	b4
C 1236	CHIP CAP.	8pF	50V	CH	GRM39CH080D50PT	K22174209		1-	B	c4
C 1237	CHIP CAP.	18pF	50V	CH	GRM39CH180J50PT	K22174217		1-	B	b4
C 1238	CHIP CAP.	220pF	50V	CH	GRM39CH221J50PT	K22174243		1-	A	D4
C 1239	CHIP CAP.	220pF	50V	CH	GRM39CH221J50PT	K22174243		1-	B	d3
C 1240	CHIP CAP.	220pF	50V	CH	GRM39CH221J50PT	K22174243		1-	A	D3
C 1241	CHIP CAP.	470pF	50V	CH	GRM39CH471J50PT	K22174249		4-	B	b4
C 1242	CHIP CAP.	470pF	50V	CH	GRM39CH471J50PT	K22174249		4-	A	C3
C 1243	CHIP CAP.	470pF	50V	CH	GRM39CH471J50PT	K22174249		4-	A	C3
C 1265	CHIP CAP.	470pF	50V	CH	GRM39CH471J50PT	K22174249		1-	A	C3
C 1266	CHIP CAP.	0.001uF	50V	B	GRM39B102K50PT	K22174821		1-	B	g5
C 1267	CHIP CAP.	470pF	50V	CH	GRM39CH471J50PT	K22174249		1-	B	c3
C 1268	CHIP CAP.	470pF	50V	CH	GRM39CH471J50PT	K22174249		1-	B	b4
C 1269	CHIP CAP.	470pF	50V	CH	GRM39CH471J50PT	K22174249		1-	A	C3
C 1270	CHIP CAP.	470pF	50V	CH	GRM39CH471J50PT	K22174249		4-	A	F2
C 1271	CHIP CAP.	0.5pF	50V	CK	GRM39CK0R5C50PT	K22174201	VERSION A	3-		
C 2001	CHIP TA.CAP.	10uF	10V		TEMSVA1A106M-8R	K78100028		1-	A	A1
C 2002	CHIP TA.CAP.	10uF	10V		TEMSVA1A106M-8R	K78100028		1-	A	A1
C 2003	CHIP CAP.	100pF	50V	CH	GRM39CH101J50PT	K22174235		1-	B	g4
C 2004	CHIP CAP.	100pF	50V	CH	GRM39CH101J50PT	K22174235		1-	A	B1
C 2005	CHIP CAP.	100pF	50V	CH	GRM39CH101J50PT	K22174235		1-	A	A1
C 2006	CHIP CAP.	100pF	50V	CH	GRM39CH101J50PT	K22174235		1-	A	A1
C 2007	CHIP CAP.	100pF	50V	CH	GRM39CH101J50PT	K22174235		1-	A	A1
C 2008	CHIP CAP.	100pF	50V	CH	GRM39CH101J50PT	K22174235		1-	A	B1
C 2009	CHIP CAP.	100pF	50V	CH	GRM39CH101J50PT	K22174235		1-	B	g1
C 2010	CHIP CAP.	100pF	50V	CH	GRM39CH101J50PT	K22174235		1-	B	f5
C 2011	CHIP CAP.	100pF	50V	CH	GRM39CH101J50PT	K22174235		1-	B	f5
C 2012	CHIP TA.CAP.	4.7uF	10V		TEMSVA1A475M-8R	K78100022		1-	B	f5
C 2012	CHIP TA.CAP.	4.7uF	16V		TEMSVA1C475M-8R	K78120031		4-	B	f5
C 2013	CHIP CAP.	220pF	50V	CH	GRM39CH221J50PT	K22174243		1-	B	f5
C 2014	CHIP CAP.	100pF	50V	CH	GRM39CH101J50PT	K22174235		1-	B	f5
C 2015	CHIP CAP.	100pF	50V	CH	GRM39CH101J50PT	K22174235		1-	B	f5
C 2016	CHIP TA.CAP.	4.7uF	10V		TEMSVA1A475M-8R	K78100022		1-	B	f5
C 2016	CHIP TA.CAP.	4.7uF	16V		TEMSVA1C475M-8R	K78120031		4-	B	f5
C 2018	CHIP CAP.	100pF	50V	CH	GRM39CH101J50PT	K22174235		1-	B	e5
C 2019	CHIP TA.CAP.	4.7uF	10V		TEMSVA1A475M-8R	K78100022		1-	B	e5
C 2019	CHIP TA.CAP.	4.7uF	16V		TEMSVA1C475M-8R	K78120031		4-	B	e5
C 2020	AL.ELECTRO.CAP.	100uF	16V		ECEV1CA101WP	K48120012		1-	A	A2
C 2021	CHIP CAP.	0.1uF	16V	B	GRM39B104K16PT	K22124805		1-	A	A2
C 2022	CHIP CAP.	0.001uF	50V	B	GRM39B102K50PT	K22174821		1-	A	B5
C 2023	CHIP CAP.	0.001uF	50V	B	GRM39B102K50PT	K22174821		1-	B	f5
C 2024	CHIP CAP.	0.1uF	16V	B	GRM39B104K16PT	K22124805		1-	B	g3
C 2024	CHIP CAP.	0.22uF	10V	B	GRM39B224K10PT	K22104801		4-	B	g3
C 2027	CHIP CAP.	220pF	50V	CH	GRM39CH221J50PT	K22174243		1-	B	e5
C 2028	CHIP CAP.	0.1uF	16V	B	GRM39B104K16PT	K22124805		1-	A	C5
C 2029	CHIP CAP.	0.1uF	16V	B	GRM39B104K16PT	K22124805		1-	B	f5
C 2030	CHIP CAP.	47pF	50V	CH	GRM39CH470J50PT	K22174227		1-	B	f5



REF.	DESCRIPTION	VALUE	WV	TOL.	MFR'S DESIG	VXSTD P/N	VERS.	LOT.	SIDE.	LAY ADR.
C 2031	CHIP TA.CAP.	10uF	10V		TEMSVA1A106M-8R	K78100028		1-	B	g3
C 2032	CHIP TA.CAP.	10uF	10V		TEMSVA1A106M-8R	K78100028		1-	A	A3
C 2034	CHIP CAP.	1uF	10V	F	GRM39F105Z10PT	K22105001		1-	A	A3
C 2036	CHIP CAP.	0.1uF	16V	B	GRM39B104K16PT	K22124805		1-	B	e5
C 2037	CHIP CAP.	0.1uF	16V	B	GRM39B104K16PT	K22124805		1-	A	C5
C 2038	CHIP CAP.	0.1uF	16V	B	GRM39B104K16PT	K22124805		1-	B	f3
C 2039	CHIP CAP.	0.047uF	16V	B	GRM39B473K16PT	K22124804		1-	B	f3
C 2040	CHIP TA.CAP.	1uF	16V		TESVA1C105M1-8R	K78120009		1-	B	d4
C 2041	CHIP TA.CAP.	4.7uF	10V		TEMSVA1A475M-8R	K78100022		1-	A	D4
C 2041	CHIP TA.CAP.	4.7uF	16V		TEMSVA1C475M-8R	K78120031		4-	A	D4
C 2042	CHIP TA.CAP.	1uF	16V		TESVA1C105M1-8R	K78120009		1-	A	D4
C 2043	CHIP CAP.	0.0022uF	50V	B	GRM39B222M50PT	K22174813		1-	A	C5
C 2043	CHIP CAP.	0.0022uF	50V	B	GRM39B222K50PT	K22174822		4-	A	C5
C 2044	CHIP CAP.	270pF	50V	B	GRM39B271M50PT	K22174802		1-	B	d5
C 2045	CHIP CAP.	0.01uF	25V	B	GRM39B103K25PT	K22144803		1-	B	d4
C 2046	CHIP CAP.	0.01uF	25V	B	GRM39B103K25PT	K22144803		1-	B	d4
C 2047	CHIP CAP.	0.01uF	25V	B	GRM39B103K25PT	K22144803		1-	A	C5
C 2048	CHIP CAP.	0.022uF	25V	B	GRM39B223K25PT	K22144807		1-	A	C4
C 2049	CHIP CAP.	0.1uF	16V	B	GRM39B104K16PT	K22124805		1-	A	D5
C 2050	CHIP CAP.	0.1uF	16V	B	GRM39B104K16PT	K22124805		1-	B	e4
C 2051	CHIP CAP.	0.1uF	16V	B	GRM39B104K16PT	K22124805		1-	B	e4
C 2052	CHIP CAP.	0.1uF	16V	B	GRM39B104K16PT	K22124805		1-	B	e4
C 2053	CHIP TA.CAP.	1uF	16V		TESVA1C105M1-8R	K78120009		1-	A	C4
C 2055	CHIP CAP.	0.1uF	16V	B	GRM39B104K16PT	K22124805		1-	B	e4
C 2056	CHIP CAP.	0.01uF	25V	B	GRM39B103K25PT	K22144803		1-	A	C3
C 2057	CHIP TA.CAP.	4.7uF	10V		TEMSVA1A475M-8R	K78100022		1-	A	C3
C 2057	CHIP TA.CAP.	4.7uF	16V		TEMSVA1C475M-8R	K78120031		4-	A	C3
C 2058	CHIP CAP.	220pF	50V	CH	GRM39CH221J50PT	K22174243		1-	A	C3
C 2059	CHIP CAP.	220pF	50V	CH	GRM39CH221J50PT	K22174243		1-	A	C3
C 2060	CHIP CAP.	0.01uF	25V	B	GRM39B103K25PT	K22144803		1-	A	B4
C 2061	CHIP CAP.	0.01uF	25V	B	GRM39B103K25PT	K22144803		1-	A	B4
C 2062	CHIP TA.CAP.	4.7uF	10V		TEMSVA1A475M-8R	K78100022		1-	A	C5
C 2062	CHIP TA.CAP.	4.7uF	16V		TEMSVA1C475M-8R	K78120031		4-	A	C5
C 2063	CHIP CAP.	0.1uF	16V	B	GRM39B104K16PT	K22124805		1-	A	C5
C 2064	CHIP CAP.	0.0022uF	50V	B	GRM39B222K50PT	K22174822		1-	A	C5
C 2065	CHIP TA.CAP.	4.7uF	10V		TEMSVA1A475M-8R	K78100022		1-	A	C5
C 2065	CHIP TA.CAP.	4.7uF	16V		TEMSVA1C475M-8R	K78120031		4-	A	C5
C 2066	CHIP CAP.	0.022uF	25V	B	GRM39B223K25PT	K22144807		1-	B	e4
C 2067	CHIP CAP.	0.001uF	50V	B	GRM39B102K50PT	K22174821		1-	B	e5
C 2068	CHIP CAP.	270pF	50V	B	GRM39B271M50PT	K22174802		1-	B	d5
C 2069	CHIP TA.CAP.	10uF	10V		TEMSVA1A106M-8R	K78100028		1-	A	D5
C 2070	CHIP CAP.	470pF	50V	CH	GRM39CH471J50PT	K22174249		1-	B	d4
C 2071	CHIP CAP.	330pF	50V	B	GRM39B331K50PT	K22174820		1-	B	d4
C 2072	CHIP CAP.	0.1uF	16V	B	GRM39B104K16PT	K22124805		1-	B	d4
C 2073	CHIP CAP.	0.01uF	25V	B	GRM39B103K25PT	K22144803		1-	B	d5
C 2074	CHIP CAP.	470pF	50V	CH	GRM39CH471J50PT	K22174249		1-	B	d4
C 2075	CHIP TA.CAP.	1uF	16V		TESVA1C105M1-8R	K78120009		1-	A	D4
C 2076	CHIP CAP.	470pF	50V	CH	GRM39CH471J50PT	K22174249		1-	B	d4
C 2078	CHIP CAP.	0.1uF	16V	B	GRM39B104K16PT	K22124805		1-	A	C4
C 2079	CHIP CAP.	22pF	50V	CH	GRM39CH220J50PT	K22174219		1-	B	d4
C 2080	CHIP CAP.	0.1uF	16V	B	GRM39B104K16PT	K22124805		1-	A	C5
C 2081	CHIP CAP.	0.001uF	50V	B	GRM39B102K50PT	K22174821		1-	A	C5
C 2082	CHIP TA.CAP.	4.7uF	10V		TEMSVA1A475M-8R	K78100022		1-	A	D5
C 2082	CHIP TA.CAP.	4.7uF	16V		TEMSVA1C475M-8R	K78120031		4-	A	D5
C 2083	CHIP CAP.	22pF	50V	CH	GRM39CH220J50PT	K22174219		1-	B	e5
C 2084	CHIP CAP.	0.01uF	25V	B	GRM39B103K25PT	K22144803		1-	B	d5
C 2085	CHIP CAP.	0.01uF	25V	B	GRM39B103K25PT	K22144803		1-	B	d5
C 2086	CHIP CAP.	330pF	50V	B	GRM39B331K50PT	K22174820		1-	B	d5
C 2087	CHIP CAP.	0.01uF	25V	B	GRM39B103K25PT	K22144803		1-	B	d5
C 2088	CHIP CAP.	0.01uF	25V	B	GRM39B103K25PT	K22144803		1-	B	d5

# MAIN Unit

REF.	DESCRIPTION	VALUE	WV	TOL.	MFR'S DESIG	VXSTD P/N	VERS.	LOT.	SIDE	LAY ADR.
C 2089	CHIP CAP.	470pF	50V	CH	GRM39CH471J50PT	K22174249		1-	B	d4
C 2090	CHIP CAP.	0.0047uF	50V	B	GRM39B472M50PT	K22174817		1-	B	d4
C 2090	CHIP CAP.	0.0047uF	50V	B	GRM39B472K50PT	K22174833		4-	B	d4
C 2091	CHIP CAP.	9pF	50V	CH	GRM39CH090D50PT	K22174210		1-	B	g4
C 2092	CHIP CAP.	4pF	50V	CH	GRM39CH040C50PT	K22174205		1-	A	A4
C 2093	CHIP CAP.	18pF	50V	CH	GRM39CH180J50PT	K22174217		1-	A	A4
C 2094	CHIP CAP.	820pF	50V	B	GRM39B821M50PT	K22174808		1-	B	d4
C 2095	CHIP CAP.	0.0056uF	50V	B	GRM39B562M50PT	K22174818		1-	B	d4
C 2096	CHIP TA.CAP.	1uF	16V		TESVA1C105M1-8R	K78120009		1-	B	e4
C 2097	CHIP CAP.	0.1uF	16V	B	GRM39B104K16PT	K22124805		1-	A	D4
C 2098	CHIP TA.CAP.	4.7uF	10V		TEMSVA1A475M-8R	K78100022		1-	A	D4
C 2098	CHIP TA.CAP.	4.7uF	16V		TEMSVA1C475M-8R	K78120031		4-	A	D4
C 2099	CHIP TA.CAP.	4.7uF	10V		TEMSVA1A475M-8R	K78100022		1-	A	D4
C 2099	CHIP TA.CAP.	4.7uF	16V		TEMSVA1C475M-8R	K78120031		4-	A	D4
C 2100	CHIP CAP.	7pF	50V	CH	GRM39CH070D50PT	K22174208		1-	A	D4
C 2101	CHIP CAP.	0.1uF	16V	B	GRM39B104K16PT	K22124805		1-	A	D4
C 2102	CHIP CAP.	0.1uF	16V	B	GRM39B104K16PT	K22124805		1-	B	d4
C 2103	CHIP TA.CAP.	1uF	16V		TESVA1C105M1-8R	K78120009		1-	B	e4
C 2104	CHIP TA.CAP.	1uF	16V		TESVA1C105M1-8R	K78120009		1-	B	e4
C 2105	CHIP CAP.	820pF	50V	B	GRM39B821M50PT	K22174808		1-	B	e5
C 2106	CHIP CAP.	0.0012uF	50V	B	GRM39B122K50PT	K22174826		1-	B	e5
C 2107	CHIP CAP.	220pF	50V	CH	GRM39CH221J50PT	K22174243		1-	B	e5
C 2108	CHIP CAP.	0.01uF	25V	B	GRM39B103K25PT	K22144803		1-	B	d5
C 2109	CHIP CAP.	0.001uF	50V	B	GRM39B102K50PT	K22174821		1-	B	d4
C 2110	CHIP CAP.	0.0022uF	50V	B	GRM39B222K50PT	K22174822		1-	B	d5
C 2111	CHIP CAP.	100pF	50V	CH	GRM39CH101J50PT	K22174235		1-	B	d5
C 2112	CHIP CAP.	220pF	50V	CH	GRM39CH221J50PT	K22174243		1-	B	f1
C 2113	CHIP CAP.	0.01uF	25V	B	GRM39B103K25PT	K22144803		1-	B	f2
C 2114	CHIP CAP.	0.01uF	25V	B	GRM39B103K25PT	K22144803		1-	A	A5
C 2115	CHIP CAP.	0.01uF	25V	B	GRM39B103K25PT	K22144803		1-	B	d5
C 2116	CHIP CAP.	0.001uF	50V	B	GRM39B102K50PT	K22174821		1-	B	g4
C 2117	CHIP CAP.	0.022uF	25V	B	GRM39B223K25PT	K22144807		1-	B	d5
C 2118	CHIP CAP.	0.0012uF	50V	B	GRM39B122M50PT	K22174810		1-	B	d5
C 2119	AL.ELECTRO.CAP.	470uF	16V		RE3-16V471M 470UF	K40129066		1-	A	B2
C 2120	CHIP CAP.	0.001uF	50V	B	GRM39B102K50PT	K22174821		1-	B	f2
C 2122	CHIP CAP.	0.1uF	16V	B	GRM39B104K16PT	K22124805		1-	B	f4
C 2123	CHIP CAP.	0.0068uF	50V	B	GRM39B682M50PT	K22174819		1-	B	g4
C 2123	CHIP CAP.	0.0068uF	50V	B	GRM39B682K50PT	K22174834		4-	B	g4
C 2126	CHIP CAP.	0.1uF	16V	B	GRM39B104K16PT	K22124805		1-	A	D5
C 2128	CHIP CAP.	0.0022uF	50V	B	GRM39B222M50PT	K22174813		1-	B	g4
C 2128	CHIP CAP.	0.0022uF	50V	B	GRM39B222K50PT	K22174822		4-	B	g4
C 2129	CHIP CAP.	47pF	50V	CH	GRM39CH470J50PT	K22174227		1-	B	d5
C 2130	CHIP CAP.	0.001uF	50V	B	GRM39B102K50PT	K22174821		1-	B	f2
C 2131	CHIP CAP.	0.01uF	25V	B	GRM39B103K25PT	K22144803		1-	B	f3
C 2132	CHIP CAP.	0.22uF	10V	B	GRM39B224K10PT	K22104801		1-	B	f2
C 2133	CHIP TA.CAP.	4.7uF	10V		TEMSVA1A475M-8R	K78100022		1-	B	g5
C 2134	CHIP TA.CAP.	10uF	10V		TEMSVA1A106M-8R	K78100028		1-	B	f2
C 2135	CHIP CAP.	0.01uF	25V	B	GRM39B103K25PT	K22144803		1-	B	f2
C 2137	CHIP TA.CAP.	4.7uF	10V		TEMSVA1A475M-8R	K78100022		1-	B	f5
C 2137	CHIP TA.CAP.	4.7uF	16V		TEMSVA1C475M-8R	K78120031		4-	B	f5
C 2138	CHIP TA.CAP.	4.7uF	10V		TEMSVA1A475M-8R	K78100022		1-	B	f3
C 2138	CHIP TA.CAP.	4.7uF	16V		TEMSVA1C475M-8R	K78120031		4-	B	f3
C 2139	CHIP CAP.	0.1uF	16V	B	GRM39B104K16PT	K22124805		1-	B	f4
C 2140	CHIP CAP.	0.1uF	16V	B	GRM39B104K16PT	K22124805		1-	B	g4
C 2141	CHIP TA.CAP.	4.7uF	10V		TEMSVA1A475M-8R	K78100022		1-	B	e4
C 2141	CHIP TA.CAP.	4.7uF	16V		TEMSVA1C475M-8R	K78120031		4-	B	e4
C 2142	CHIP CAP.	100pF	50V	CH	GRM39CH101J50PT	K22174235		1-	A	B1
C 2143	CHIP CAP.	100pF	50V	CH	GRM39CH101J50PT	K22174235		1-	A	B1
C 2144	CHIP TA.CAP.	4.7uF	10V		TEMSVA1A475M-8R	K78100022		1-	A	C5
C 2144	CHIP TA.CAP.	4.7uF	16V		TEMSVA1C475M-8R	K78120031		4-	A	C5

REF.	DESCRIPTION	VALUE	WV	TOL.	MFR'S DESIG	VXSTD P/N	VERS.	LOT.	SIDE.	LAY ADR.
C 2145	CHIP TA.CAP.	4.7uF	10V		TEMSVA1A475M-8R	K78100022		1-	A	C5
C 2145	CHIP TA.CAP.	4.7uF	16V		TEMSVA1C475M-8R	K78120031		4-	A	C5
C 2146	CHIP CAP.	470pF	50V	B	GRM39B471M50PT	K22174805		1-	B	f5
C 2146	CHIP CAP.	470pF	50V	CH	GRM39CH471J50PT	K22174249		4-	B	f5
C 2147	CHIP CAP.	470pF	50V	B	GRM39B471M50PT	K22174805		1-	B	f5
C 2147	CHIP CAP.	470pF	50V	CH	GRM39CH471J50PT	K22174249		4-	B	f5
C 2148	CHIP CAP.	470pF	50V	B	GRM39B471M50PT	K22174805		1-	B	f5
C 2148	CHIP CAP.	470pF	50V	CH	GRM39CH471J50PT	K22174249		4-	B	f5
C 2149	CHIP CAP.	470pF	50V	B	GRM39B471M50PT	K22174805		1-	B	g5
C 2149	CHIP CAP.	470pF	50V	CH	GRM39CH471J50PT	K22174249		4-	B	g5
C 2150	CHIP CAP.	0.1uF	16V	B	GRM39B104K16PT	K22124805		1-	A	C5
C 2156	CHIP CAP.	100pF	50V	CH	GRM39CH101J50PT	K22174235		1-	A	B1
C 2157	CHIP CAP.	100pF	50V	CH	GRM39CH101J50PT	K22174235		1-	A	A1
C 2158	CHIP CAP.	100pF	50V	CH	GRM39CH101J50PT	K22174235		1-	A	A1
C 2159	CHIP CAP.	100pF	50V	CH	GRM39CH101J50PT	K22174235		1-	A	A1
C 2160	CHIP CAP.	100pF	50V	CH	GRM39CH101J50PT	K22174235		1-	A	A1
C 2161	CHIP CAP.	100pF	50V	CH	GRM39CH101J50PT	K22174235		1-	A	A1
C 2162	CHIP CAP.	100pF	50V	CH	GRM39CH101J50PT	K22174235		1-	A	A1
C 2163	CHIP CAP.	100pF	50V	CH	GRM39CH101J50PT	K22174235		1-	A	A1
C 2164	CHIP CAP.	100pF	50V	CH	GRM39CH101J50PT	K22174235		1-	A	A1
C 2165	CHIP CAP.	100pF	50V	CH	GRM39CH101J50PT	K22174235		1-	A	B1
C 2166	CHIP CAP.	100pF	50V	CH	GRM39CH101J50PT	K22174235		1-	A	B1
C 2167	CHIP CAP.	100pF	50V	CH	GRM39CH101J50PT	K22174235		1-	A	B1
C 2168	CHIP CAP.	100pF	50V	CH	GRM39CH101J50PT	K22174235		1-	A	B1
C 2169	CHIP CAP.	100pF	50V	CH	GRM39CH101J50PT	K22174235		1-	A	B1
C 2170	CHIP CAP.	100pF	50V	CH	GRM39CH101J50PT	K22174235		1-	A	B1
C 2172	CHIP CAP.	0.01uF	25V	B	GRM39B103K25PT	K22144803		1-	B	f3
C 2173	CHIP CAP.	0.01uF	25V	B	GRM39B103K25PT	K22144803		1-	B	f3
C 2174	CHIP CAP.	0.01uF	25V	B	GRM39B103K25PT	K22144803		1-	B	f3
C 2175	CHIP CAP.	0.01uF	25V	B	GRM39B103K25PT	K22144803		1-	B	f3
C 2176	CHIP CAP.	470pF	50V	CH	GRM39CH471J50PT	K22174249		1-	A	A5
C 2177	CHIP CAP.	470pF	50V	CH	GRM39CH471J50PT	K22174249		1-	A	B3
C 2178	CHIP CAP.	470pF	50V	CH	GRM39CH471J50PT	K22174249		1-	A	A3
C 2179	CHIP CAP.	470pF	50V	CH	GRM39CH471J50PT	K22174249		1-	A	B2
C 2197	CHIP CAP.	470pF	50V	CH	GRM39CH471J50PT	K22174249		1-	B	a3
C 2198	CHIP CAP.	470pF	50V	CH	GRM39CH471J50PT	K22174249		1-	A	B2
C 2199	CHIP CAP.	0.1uF	16V	B	GRM39B104K16PT	K22124805		1-	B	g3
C 2200	CHIP CAP.	0.01uF	25V	B	GRM39B103K25PT	K22144803		4-	A	B3
C 2201	CHIP CAP.	0.047uF	16V	B	GRM39B473K16PT	K22124804		1-	B	f2
C 2203	CHIP CAP.	0.1uF	16V	B	GRM39B104K16PT	K22124805		1-	B	g3
C 2203	CHIP CAP.	0.22uF	10V	B	GRM39B224K10PT	K22104801		4-	B	g3
C 2204	CHIP CAP.	0.1uF	16V	B	GRM39B104K16PT	K22124805		1-3	A	B2
C 2205	CHIP CAP.	0.1uF	16V	B	GRM39B104K16PT	K22124805		1-3	B	f3
C 2206	CHIP CAP.	100pF	50V	CH	GRM39CH101J50PT	K22174235		4-	A	A5
C 2207	CHIP CAP.	0.001uF	50V	B	GRM39B102K50PT	K22174821		4-	B	g5
C 2208	AL.ELECTRO.CAP.	10uF	16V		RV2-16V100MB55-R	K48120014		4-	A	B2
C 2209	CHIP CAP.	0.1uF	16V	B	GRM39B104K16PT	K22124805		1-		
CD1001	CERAMIC DISC				CDBC450CX24-TC	H7901340		1-	B	a4
CF1001	CERAMIC FILTER				CFWM450G	H3900435		1-	A	G5
CF1002	CERAMIC FILTER				CFWM450E	H3900466		1-	A	G4
CO2001	CERAMIC OSC	1MHz			CSBF1000J221T-TC01	H7900950		1-	A	B3
D 1001	DIODE				RLS135 TE-11	G2070128		1-	A	G3
D 1002	DIODE				BAS316	G2070716		1-	A	G2
D 1003	SURGE ABSORBER				P6KA18	Q9000721		1-	A	B1
D 1005	DIODE				BAS316	G2070716		1-	A	D3
D 1006	DIODE				UM9957F/TR	G2070562		1-	B	a2
D 1008	DIODE				UM9957F/TR	G2070562		1-	B	a2
D 1011	DIODE				HSM88AS TR	G2070170		1-	B	b2
D 1012	DIODE				HVU350TRF	G2070380		1-	A	G3
D 1013	DIODE				HVU350TRF	G2070380		1-	A	F3

# MAIN Unit

REF.	DESCRIPTION	VALUE	WV	TOL.	MFR'S DESIG	VXSTD P/N	VERS.	LOT.	SIDE	LAY ADR.
D 1014	DIODE				HSM88AS TR	G2070170		1-	B	b2
D 1015	DIODE				1SV276(TPH3)	G2070420		1-	A	E5
D 1016	DIODE				1SV276(TPH3)	G2070420		1-	A	E5
D 1017	DIODE				1SV276(TPH3)	G2070420		1-	A	E5
D 1018	DIODE				1SV276(TPH3)	G2070420		1-	A	E5
D 1019	DIODE				1SV230 TPH3	G2070126		1-	A	D5
D 1020	DIODE				HVU350TRF	G2070380		1-	A	F3
D 1022	DIODE				HVU350TRF	G2070380		1-	A	E3
D 1024	DIODE				1SS321 TE85R	G2070076		1-	B	d3
D 1026	DIODE				MC2848-T11-1	G2070694		1-	B	a5
D 1027	DIODE				HZM5.6NB2 TR	G2070722		1-	A	G5
D 1028	DIODE				MC2848-T11-1	G2070694		1-	B	a5
D 1029	DIODE				HVU350TRF	G2070380		1-	B	b5
D 1030	DIODE				1SV230 TPH3	G2070126		1-	B	b5
D 1031	SURGE ABSORBER				P6KA18	Q9000721		1-		
D 1032	DIODE				BAS316	G2070716		1-	B	e3
D 1033	DIODE				MC2850-T11-1	G2070704		1-	B	a5
D 1034	DIODE				BAS316	G2070716		1-	B	d3
D 2001	DIODE				MC2846-T11-1	G2070702		1-	B	g4
D 2002	DIODE				MC2850-T11-1	G2070704		1-	B	d4
D 2003	DIODE				MC2850-T11-1	G2070704		1-	A	C4
D 2004	DIODE				MC2850-T11-1	G2070704		1-	A	D4
D 2005	DIODE				BAS316	G2070716		1-	A	C4
D 2006	DIODE				MC2850-T11-1	G2070704		1-	B	f5
D 2007	DIODE				MC2846-T11-1	G2070702		1-	B	f2
D 2010	DIODE				MC2850-T11-1	G2070704		1-	B	g3
D 2011	DIODE				BAS316	G2070716		1-	A	A2
D 2012	DIODE				BAS316	G2070716		1-	B	g1
D 2013	DIODE				BAS316	G2070716		1-	B	g1
D 2014	DIODE				BAS316	G2070716		1-	A	A4
D 2015	DIODE				BAS316	G2070716		1-	A	A5
F 2001	CHIP FUSE	0.25A			KAB-2402-251NA31	Q0000085		1-	A	A1
J 2001	CONNECTOR				JBY-25S-1A3F	P1090815		1-	B	f1
J 2004	CONNECTOR				BM03B-SRSS-TBT	P0091301		1-	A	A2
J 2005	CONNECTOR				AXN426C530P	P0091296		1-	A	B4
L 1001	COIL	0.015uH			AS1203-15NK	L0022543		1-2	A	G1
L 1001	COIL	0.015uH			AS1203-15NK	L0022543	VERSION A	3-	A	G1
L 1001	COIL	0.015uH			AS1203-15NK	L0022543	VERSION D	3-	A	G1
L 1001	COIL	0.01uH			AS1003-10NK	L0022544	VERSION F	4-	A	G1
L 1002	COIL				E2 0.4-1.5-4T-L	L0022475		1-	A	G2
L 1003	COIL	0.01uH			AS1003-10NK	L0022544		1-2	A	G2
L 1003	COIL	0.015uH			AS1203-15NK	L0022543	VERSION A	3-	A	G2
L 1003	COIL	0.01uH			AS1003-10NK	L0022544	VERSION D	3-	A	G2
L 1003	COIL	0.01uH			AS1003-10NK	L0022544	VERSION F	4-	A	G2
L 1004	COIL	0.015uH			AS1203-15NK	L0022543		1-	A	G2
L 1005	COIL	0.015uH			AS0803-15NK	L0022536		1-	A	G2
L 1006	COIL				E2 0.35-1.6-4T-L	L0022456		1-	A	G3
L 1007	COIL	0.047uH			AS1007-47NK	L0022548		1-	A	F2
L 1008	COIL				E2 0.35-1.6-4T-L	L0022456		1-	A	G3
L 1009	COIL				E2 0.35-1.6-4T-L	L0022456		1-2	A	G3
L 1009	COIL				E2 0.35-1.6-5.5T-L	L0022616	VERSION A	3-	A	G3
L 1009	COIL				E2 0.35-1.6-4T-L	L0022456	VERSION D	3-	A	G3
L 1009	COIL				E2 0.4-1.5-4T-L	L0022475	VERSION F	4-	A	G3
L 1010	M.RFC	0.12uH		5%	C1608CA-R12J	L1691065		1-	A	E5
L 1011	M.RFC	0.12uH		5%	C1608CA-R12J	L1691065		1-	A	E5
L 1012	M.RFC	0.082uH			HK1608 82NJ-T	L1690527		1-2	A	E5
L 1012	M.RFC	0.1uH			HK1608 R10J-T	L1690528	VERSION A	3-	A	E5
L 1012	M.RFC	0.082uH			HK1608 82NJ-T	L1690527	VERSION D	3-	A	E5
L 1012	M.RFC	0.082uH			HK1608 82NJ-T	L1690527	VERSION F	4-	A	E5
L 1013	M.RFC	0.082uH			HK1608 82NJ-T	L1690527		1-	A	E5

REF.	DESCRIPTION	VALUE	WV	TOL.	MFR'S DESIG	VXSTD P/N	VERS.	LOT.	SIDE.	LAY ADR.
L 1014	COIL				E2 0.35-1.6-4T-L	L0022456		1-2	A	F3
L 1014	COIL				E2 0.35-1.6-5.5T-L	L0022616	VERSION A	3-	A	F3
L 1014	COIL				E2 0.35-1.6-4T-L	L0022456	VERSION D	3-	A	F3
L 1014	COIL				E2 0.4-1.5-4T-L	L0022475	VERSION F	4-	A	F3
L 1015	M.RFC	0.015uH			HK1608 15NJ-T	L1690518		1-	A	F3
L 1016	COIL				E2 0.35-2.0-4.5T-L	L0022686		1-2	A	E5
L 1016	COIL				E2 0.35-1.6-7T-L	L0022390	VERSION A	3-	A	E5
L 1016	COIL				E2 0.35-2.0-4.5T-L	L0022686	VERSION D	3-	A	E5
L 1016	COIL				E2 0.35-2.0-4.5T-L	L0022686	VERSION F	4-	A	E5
L 1017	COIL				E2 0.35-1.6-4.5T-L	L0022577		1-2	A	E5
L 1017	COIL				E2 0.35-1.6-4.5T-L	L0022577	VERSION A	3-	A	E5
L 1017	COIL				E2 0.35-1.6-4.5T-L	L0022577	VERSION D	3-	A	E5
L 1017	COIL				E2 0.35-1.6-4T-L	L0022456	VERSION F	4-	A	E5
L 1018	CHIP COIL	0.017uH			LQN1A17NJ04	L1690249		1-	A	F3
L 1019	CHIP COIL	0.0147uH			LQN1A15NJ04	L1690251		1-	B	d2
L 1020	CHIP COIL	0.0147uH			LQN1A15NJ04	L1690251		1-	B	d2
L 1021	M.RFC	0.022uH			HK1608 22NJ-T	L1690520		1-	A	E4
L 1022	COIL				E2 0.35-1.6-4T-L	L0022456		1-2	A	F3
L 1022	COIL				E2 0.35-1.6-5.5T-L	L0022616	VERSION A	3-	A	F3
L 1022	COIL				E2 0.35-1.6-4T-L	L0022456	VERSION D	3-	A	F3
L 1022	COIL				E2 0.4-1.5-4T-L	L0022475	VERSION F	4-	A	F3
L 1024	CHIP COIL	0.0147uH			LQN1A15NJ04	L1690251		1-	B	d2
L 1025	M.RFC	0.018uH			HK1608 18NJ-T	L1690519		1-	B	b5
L 1026	COIL				E2 0.35-1.6-4T-L	L0022456		1-2	A	E3
L 1026	COIL				E2 0.35-1.6-5.5T-L	L0022616	VERSION A	3-	A	E3
L 1026	COIL				E2 0.35-1.6-4T-L	L0022456	VERSION D	3-	A	E3
L 1026	COIL				E2 0.4-1.5-4T-L	L0022475	VERSION F	4-	A	E3
L 1027	COIL				E2 0.35-1.6-4T-L	L0022456		1-2	A	E3
L 1027	COIL				E2 0.35-1.6-5.5T-L	L0022616	VERSION A	3-	A	E3
L 1027	COIL				E2 0.35-1.6-4T-L	L0022456	VERSION D	3-	A	E3
L 1027	COIL				E2 0.4-1.5-4T-L	L0022475	VERSION F	4-	A	E3
L 1028	M.RFC	0.015uH			HK1608 15NJ-T	L1690518		1-	B	e3
L 1029	M.RFC	0.047uH			HK1608 47NJ-T	L1690524		1-2	B	d3
L 1029	M.RFC	0.047uH			HK1608 47NJ-T	L1690524	VERSION A	3-	B	d3
L 1029	M.RFC	0.047uH			HK1608 47NJ-T	L1690524	VERSION D	3-	B	d3
L 1029	M.RFC	0.027uH			HK1608 27NJ-T	L1690521	VERSION F	4-	B	d3
L 1030	M.RFC	0.022uH			HK1608 22NJ-T	L1690520		1-	B	c4
L 1031	M.RFC	0.022uH			HK1608 22NJ-T	L1690520		1-	B	c4
L 1032	COIL				E2 0.35-1.6-4T-L	L0022456		1-2	A	E3
L 1032	COIL				E2 0.35-1.6-5.5T-L	L0022616	VERSION A	3-	A	E3
L 1032	COIL				E2 0.35-1.6-4T-L	L0022456	VERSION D	3-	A	E3
L 1032	COIL				E2 0.4-1.5-4T-L	L0022475	VERSION F	4-	A	E3
L 1033	CHIP COIL	0.082uH			C2520C-82NK	L1690543		1-	A	F4
L 1034	M.RFC	0.047uH			HK1608 47NJ-T	L1690524		1-2	A	E4
L 1034	M.RFC	0.047uH			HK1608 47NJ-T	L1690524	VERSION A	3-	A	E4
L 1034	M.RFC	0.047uH			HK1608 47NJ-T	L1690524	VERSION D	3-	A	E4
L 1034	M.RFC	0.039uH			HK1608 39NJ-T	L1690523	VERSION F	4-	A	E4
L 1035	M.RFC	0.068uH			HK1608 68NJ-T	L1690526		1-	A	E4
L 1037	M.RFC	0.33uH			LK1608 R33K-T	L1690412		1-	A	G4
L 1038	M.RFC	0.82uH			LK1608 R82K-T	L1690417		1-	B	a4
L 1039	M.RFC	0.015uH			HK1608 15NJ-T	L1690518		1-	B	b4
L 1040	M.RFC	0.039uH			HK1608 39NJ-T	L1690523		1-2	A	E4
L 1040	M.RFC	0.056uH			HK1608 56NJ-T	L1690525	VERSION A	3-	A	E4
L 1040	M.RFC	0.039uH			HK1608 39NJ-T	L1690523	VERSION D	3-	A	E4
L 1040	M.RFC	0.039uH			HK1608 39NJ-T	L1690523	VERSION F	4-	A	E4
L 1041	M.RFC	0.22uH		5%	C1608CA-R22J	L1691068		1-	A	E4
L 1042	M.RFC	0.12uH		5%	C1608CA-R12J	L1691065		1-	A	E4
L 1043	M.RFC	0.039uH			HK1608 39NJ-T	L1690523	VERSION F	4-	A	E4
L 2001	M.RFC	2.2uH			LK1608 2R2K-T	L1690634		1-	A	A4
Q 1001	TRANSISTOR				2SC4154-T11-1E	G3341548E		1-	A	D3

# MAIN Unit

REF.	DESCRIPTION	VALUE	WV	TOL.	MFR'S DESIG	VXSTD P/N	VERS.	LOT.	SIDE	LAY ADR.
Q 1002	TRANSISTOR				2SB1143S	G3211430S		1-	B	d2
Q 1003	TRANSISTOR				2SB1201S-TL	G3070195		1-	B	e3
Q 1004	TRANSISTOR				RT1N241M-T11-1	G3070249		1-	A	D3
Q 1005	TRANSISTOR				DTB123EK T146	G3070022		1-	B	e3
Q 1006	TRANSISTOR				2SB1132 T100 R	G3211327R		1-	B	e3
Q 1007	IC				M5223AGP 600C	G1093020		1-	B	d3
Q 1008	TRANSISTOR				2SC4154-T11-1E	G3341548E		1-	B	d3
Q 1009	TRANSISTOR				IMH6A T108	G3070066		1-	A	C3
Q 1011	TRANSISTOR				RT1N241M-T11-1	G3070249		1-	B	d5
Q 1012	TRANSISTOR				2SC4227-T2 R34	G3342277D		1-	A	F3
Q 1013	IC				M68769H-01	G1093234		1-2	A	C1
Q 1013	IC				M68769L-01	G1093233	VERSION A	3-	A	C1
Q 1013	IC				M68769H-01	G1093234	VERSION D	3-	A	C1
Q 1013	IC				M68769SH-01	G1093235	VERSION F	4-	A	C1
Q 1014	TRANSISTOR				2SC4226-T2B R24	G3342267D		1-	A	E4
Q 1015	FET				2SK508-T2B K52	G3805087B		1-	A	E5
Q 1016	TRANSISTOR				RT1N241M-T11-1	G3070249		1-	A	E4
Q 1017	TRANSISTOR				IMH6A T108	G3070066		1-	A	E4
Q 1018	TRANSISTOR				2SC5107-O(TE85R)	G3351077O		1-	A	E4
Q 1019	TRANSISTOR				2SC5107-O(TE85R)	G3351077O		1-	B	c4
Q 1020	TRANSISTOR				2SC2954-T2	G3329547		1-	B	d2
Q 1021	TRANSISTOR				2SC5107-O(TE85R)	G3351077O		1-	B	d4
Q 1022	TRANSISTOR				2SC5415E-TD	G3354158E		1-	B	d2
Q 1023	IC				NJM78L05UA TE1	G1091325		1-	B	a5
Q 1024	IC				SA7025DK	G1093014		1-	A	F5
Q 1025	FET				3SK228XR-TR	G4802287		1-	A	E4
Q 1026	IC				TA31136FN(EL)	G1091605		1-	A	G4
Q 1027	TRANSISTOR				2SC4116GR TE85R	G3341167G		1-	B	b4
Q 1028	TRANSISTOR				RT1N241M-T11-1	G3070249		1-	B	a5
Q 1029	TRANSISTOR				2SC4215Y TE85R	G3342157Y		1-	B	a4
Q 1030	IC				MM1216ENRE	G1092432		1-	B	e3
Q 1031	TRANSISTOR				2SC5107-O(TE85R)	G3351077O		1-	B	e3
Q 1032	TRANSISTOR				RT1N241M-T11-1	G3070249		1-	A	G4
Q 1033	TRANSISTOR				2SC4116GR TE85R	G3341167G		1-	A	C3
Q 2001	IC				NJM2902V-TE1	G1091679		1-	B	d5
Q 2002	TRANSISTOR				IMZ1 T108	G3070025		1-	B	f5
Q 2003	IC				NJM2902V-TE1	G1091679		1-	B	d4
Q 2004	TRANSISTOR				RT1N241M-T11-1	G3070249		1-	B	g1
Q 2006	TRANSISTOR				RT1N241M-T11-1	G3070249		1-	A	C5
Q 2006	TRANSISTOR				DTC323TK T146	G3070042		4-	A	C5
Q 2007	IC				BU4066BF-E2	G1092593		1-	A	C4
Q 2008	TRANSISTOR				RT1N241M-T11-1	G3070249		1-	B	f5
Q 2009	TRANSISTOR				IMX1 T110	G3070024		1-	B	g5
Q 2011	TRANSISTOR				RT1N241M-T11-1	G3070249		1-	A	B5
Q 2012	TRANSISTOR				DTC323TK T146	G3070042		1-	A	A3
Q 2013	IC				MX165CDW-TR	G1092775		1-	B	e4
Q 2014	IC				CXA1846N-T4	G1092690		1-	A	D4
Q 2015	TRANSISTOR				DTB123EK T146	G3070022		1-	B	f3
Q 2016	IC				BU4053BCF-E2	G1092723		1-	B	e5
Q 2018	TRANSISTOR				2SC4154-T11-1E	G3341548E		1-	A	A4
Q 2019	IC				MB90F583B R0509	G1093508		1-	A	B4
Q 2019	IC				MB90F583B(FLASH)	G1093208		3-	A	B4
Q 2020	FET				2SJ327-Z-E1	G4070010		1-	B	f2
Q 2024	IC				NJM78L05UA TE1	G1091325		1-	B	f2
Q 2025	TRANSISTOR				2SA1602A-T11-1F	G3116028F		1-	B	f2
Q 2026	TRANSISTOR				RT1N241M-T11-1	G3070249		1-	B	f2
Q 2027	IC				S-80735SN-DZ-T1	G1091876		1-	B	f2
Q 2027	IC				S-80835CNMC-B8U-T2	G1093606		10-	B	f2
Q 2028	IC				HN58X2432TI	G1093315		1-	A	C4
Q 2029	IC				TDA7240AV	G1091020		1-	A	A3

REF.	DESCRIPTION	VALUE	WV	TOL.	MFR'S DESIG	VXSTD P/N	VERS.	LOT.	SIDE.	LAY ADR.
Q 2108	IC				NJM2902V-TE1	G1091679		1-	B	e5
Q 2110	IC				NJM2902V-TE1	G1091679		1-	B	d5
Q 2111	TRANSISTOR				DTB123EK T146	G3070022		1-	B	g5
Q 2112	TRANSISTOR				IMD3 T108	G3070053		1-	A	A4
Q 2114	TRANSISTOR				RT1N241M-T11-1	G3070249		1-	B	g1
Q 2115	TRANSISTOR				IMD3 T108	G3070053		1-	B	g4
Q 2116	TRANSISTOR				RT1N241M-T11-1	G3070249		1-	A	B5
Q 2117	IC				TC4W53FU TE12L	G1091675		1-	A	A5
Q 2118	TRANSISTOR				RT1N241M-T11-1	G3070249		1-	B	e4
Q 2119	TRANSISTOR				RT1N241M-T11-1	G3070249		1-	A	B5
Q 2120	TRANSISTOR				RT1N241M-T11-1	G3070249		1-	B	e4
Q 2121	TRANSISTOR				RT1N241M-T11-1	G3070249		1-	B	e4
Q 2122	TRANSISTOR				RT1N241M-T11-1	G3070249		1-	B	e4
Q 2124	TRANSISTOR				RT1N241M-T11-1	G3070249		1-	A	D5
Q 2125	TRANSISTOR				RT1N241M-T11-1	G3070249		1-	B	g4
Q 2127	TRANSISTOR				RT1N241M-T11-1	G3070249		4-	B	f3
R 1001	CHIP RES.	47k	1/16W	5%	RMC1/16 473JATP	J24185473		1-	A	G1
R 1002	CHIP RES.	220k	1/16W	5%	RMC1/16 224JATP	J24185224		1-	A	D2
R 1003	CHIP RES.	1k	1/16W	5%	RMC1/16 102JATP	J24185102		1-	A	D2
R 1004	CHIP RES.	470	1/16W	5%	RMC1/16 471JATP	J24185471		1-	A	D3
R 1005	CHIP RES.	220k	1/16W	5%	RMC1/16 224JATP	J24185224		1-	A	D2
R 1006	CHIP RES.	1k	1/16W	5%	RMC1/16 102JATP	J24185102		1-	A	D3
R 1007	CHIP RES.	100k	1/16W	5%	RMC1/16 104JATP	J24185104		1-	A	D3
R 1008	CHIP RES.	100k	1/16W	5%	RMC1/16 104JATP	J24185104		1-	A	D2
R 1009	CHIP RES.	0	1/16W	5%	RMC1/16 000JATP	J24185000		1-	B	d3
R 1010	CHIP RES.	4.7k	1/16W	5%	RMC1/16 472JATP	J24185472		1-	A	D3
R 1011	CHIP RES.	100k	1/16W	5%	RMC1/16 104JATP	J24185104		1-	B	e3
R 1013	CHIP RES.	2.7k	1/16W	5%	RMC1/16 272JATP	J24185272		1-	B	b2
R 1014	CHIP RES.	10k	1/16W	5%	RMC1/16 103JATP	J24185103		1-	B	b2
R 1015	METAL FILM RES.	120	1W	5%	ERG-1SJ121P 120	J22309011		1-	A	E3
R 1017	CHIP RES.	220k	1/16W	5%	RMC1/16 224JATP	J24185224		1-	B	d2
R 1018	CHIP RES.	15k	1/16W	5%	RMC1/16 153JATP	J24185153		1-	A	D3
R 1019	CHIP RES.	10k	1/16W	5%	RMC1/16 103JATP	J24185103		1-	A	D3
R 1020	CHIP RES.	1.2k	1/16W	5%	RMC1/16 122JATP	J24185122		1-	B	d3
R 1021	CHIP RES.	2.2k	1/16W	5%	RMC1/16 222JATP	J24185222		1-	B	e3
R 1023	CHIP RES.	100k	1/16W	5%	RMC1/16 104JATP	J24185104		1-	A	F3
R 1024	CHIP RES.	100	1/2W	5%	RMC1/2 101JCTP	J24275101		1-	B	b2
R 1024	CHIP RES.	100	1/10W	5%	RMC1/10T 101J	J24205101		4-	B	b2
R 1025	CHIP RES.	2.7k	1/16W	5%	RMC1/16 272JATP	J24185272		1-	B	b2
R 1026	CHIP RES.	10k	1/16W	5%	RMC1/16 103JATP	J24185103		1-	B	b2
R 1027	CHIP RES.	100	1/2W	5%	RMC1/2 101JCTP	J24275101		1-	B	b3
R 1027	CHIP RES.	100	1/10W	5%	RMC1/10T 101J	J24205101		4-	B	b3
R 1029	CHIP RES.	100	1/16W	5%	RMC1/16 101JATP	J24185101		1-	A	E4
R 1031	CHIP RES.	330k	1/16W	5%	RMC1/16 334JATP	J24185334		1-	B	c5
R 1032	CHIP RES.	22k	1/16W	5%	RMC1/16 223JATP	J24185223		1-	A	D5
R 1033	CHIP RES.	100k	1/16W	5%	RMC1/16 104JATP	J24185104		1-	B	c5
R 1034	CHIP RES.	12k	1/16W	5%	RMC1/16 123JATP	J24185123		1-2	B	d5
R 1034	CHIP RES.	15k	1/16W	5%	RMC1/16 153JATP	J24185153	VERSION A	3-	B	d5
R 1034	CHIP RES.	12k	1/16W	5%	RMC1/16 123JATP	J24185123	VERSION D	3-	B	d5
R 1034	CHIP RES.	15k	1/16W	5%	RMC1/16 153JATP	J24185153	VERSION F	4-	B	d5
R 1035	CHIP RES.	10k	1/16W	5%	RMC1/16 103JATP	J24185103		1-	A	D5
R 1036	CHIP RES.	100k	1/16W	5%	RMC1/16 104JATP	J24185104		1-	B	d5
R 1037	CHIP RES.	330k	1/16W	5%	RMC1/16 334JATP	J24185334		1-	B	c5
R 1038	CHIP RES.	100k	1/16W	5%	RMC1/16 104JATP	J24185104		1-	B	a3
R 1039	CHIP RES.	47	1/16W	5%	RMC1/16 470JATP	J24185470		1-	B	b3
R 1040	CHIP RES.	100k	1/16W	5%	RMC1/16 104JATP	J24185104		1-	A	F3
R 1041	CHIP RES.	5.6	1/10W	5%	RMC1/10T 5R6J	J24205569		1-	B	e2
R 1043	CHIP RES.	560	1/10W	5%	RMC1/10T 561J	J24205561		1-	B	d2
R 1045	CHIP RES.	270	1/16W	5%	RMC1/16 271JATP	J24185271		1-	A	E4
R 1047	CHIP RES.	4.7k	1/16W	5%	RMC1/16 472JATP	J24185472		1-	A	E4

# MAIN Unit

REF.	DESCRIPTION	VALUE	WV	TOL.	MFR'S DESIG	VXSTD P/N	VERS.	LOT.	SIDE	LAY ADR.
R 1048	CHIP RES.	10k	1/16W	5%	RMC1/16 103JATP	J24185103		1-	A	D5
R 1049	CHIP RES.	10k	1/16W	5%	RMC1/16 103JATP	J24185103		1-	A	E4
R 1050	CHIP RES.	4.7k	1/16W	5%	RMC1/16 472JATP	J24185472		1-	A	E5
R 1051	CHIP RES.	4.7k	1/16W	5%	RMC1/16 472JATP	J24185472		1-	A	E5
R 1052	CHIP RES.	22k	1/16W	5%	RMC1/16 223JATP	J24185223		1-	A	F3
R 1053	CHIP RES.	10k	1/16W	5%	RMC1/16 103JATP	J24185103		1-	A	F3
R 1054	CHIP RES.	1k	1/16W	5%	RMC1/16 102JATP	J24185102		1-	A	F3
R 1055	CHIP RES.	100	1/16W	5%	RMC1/16 101JATP	J24185101		1-	A	F3
R 1058	CHIP RES.	4.7	1/4W	5%	RMC1/4 4R7JATP	J24245479		1-	A	D2
R 1059	CHIP RES.	2.2	1/8W	5%	RMC1/8T 2R2J	J24215229		1-	B	d2
R 1060	CHIP RES.	100	1/16W	5%	RMC1/16 101JATP	J24185101		1-	A	E4
R 1061	CHIP RES.	4.7k	1/16W	5%	RMC1/16 472JATP	J24185472		1-	A	E4
R 1063	CHIP RES.	100	1/16W	5%	RMC1/16 101JATP	J24185101		1-	B	c5
R 1064	CHIP RES.	4.7k	1/16W	5%	RMC1/16 472JATP	J24185472		1-	A	E4
R 1065	CHIP RES.	220	1/16W	5%	RMC1/16 221JATP	J24185221		1-	A	E4
R 1066	CHIP RES.	680	1/16W	5%	RMC1/16 681JATP	J24185681		1-	A	E4
R 1067	CHIP RES.	4.7k	1/16W	5%	RMC1/16 472JATP	J24185472		1-	A	E4
R 1068	CHIP RES.	3.3k	1/16W	5%	RMC1/16 332JATP	J24185332		1-	A	E5
R 1069	CHIP RES.	270	1/16W	5%	RMC1/16 271JATP	J24185271		1-	A	E5
R 1070	CHIP RES.	0	1/16W	5%	RMC1/16 000JATP	J24185000		1-	A	F5
R 1072	CHIP RES.	100k	1/16W	5%	RMC1/16 104JATP	J24185104		1-	B	b3
R 1073	CHIP RES.	100k	1/16W	5%	RMC1/16 104JATP	J24185104		1-	A	F3
R 1074	CHIP RES.	100k	1/16W	5%	RMC1/16 104JATP	J24185104		1-	A	E3
R 1075	CHIP RES.	1k	1/16W	5%	RMC1/16 102JATP	J24185102		1-	B	d2
R 1077	CHIP RES.	33	1/10W	5%	RMC1/10T 330J	J24205330		1-	A	C3
R 1078	CHIP RES.	10	1/16W	5%	RMC1/16 100JATP	J24185100		1-	B	c4
R 1079	CHIP RES.	100k	1/16W	5%	RMC1/16 104JATP	J24185104		1-	B	c4
R 1080	CHIP RES.	120	1/16W	5%	RMC1/16 121JATP	J24185121		1-	B	c4
R 1081	CHIP RES.	10k	1/16W	5%	RMC1/16 103JATP	J24185103		1-	A	F5
R 1082	CHIP RES.	56	1/16W	5%	RMC1/16 560JATP	J24185560		1-	B	c4
R 1083	CHIP RES.	22	1/16W	5%	RMC1/16 220JATP	J24185220		1-	B	b5
R 1084	CHIP RES.	100	1/16W	5%	RMC1/16 101JATP	J24185101		1-	B	e2
R 1086	CHIP RES.	100	1/16W	5%	RMC1/16 101JATP	J24185101		1-	A	D3
R 1087	CHIP RES.	1k	1/16W	5%	RMC1/16 102JATP	J24185102		1-	B	d4
R 1088	CHIP RES.	1k	1/16W	5%	RMC1/16 102JATP	J24185102		1-	B	d3
R 1089	CHIP RES.	10k	1/16W	5%	RMC1/16 103JATP	J24185103		1-	B	b5
R 1090	CHIP RES.	6.8k	1/16W	5%	RMC1/16 682JATP	J24185682		1-	B	b5
R 1091	CHIP RES.	1k	1/16W	5%	RMC1/16 102JATP	J24185102		1-	B	b4
R 1092	CHIP RES.	1k	1/16W	5%	RMC1/16 102JATP	J24185102		1-	B	b4
R 1093	CHIP RES.	1k	1/16W	5%	RMC1/16 102JATP	J24185102		1-	B	b4
R 1094	CHIP RES.	22	1/16W	5%	RMC1/16 220JATP	J24185220		1-	B	b4
R 1095	CHIP RES.	0	1/16W	5%	RMC1/16 000JATP	J24185000		1-	B	c4
R 1097	CHIP RES.	270	1/10W	5%	RMC1/10T 271J	J24205271		1-	A	G4
R 1098	CHIP RES.	1k	1/16W	5%	RMC1/16 102JATP	J24185102		1-	B	c3
R 1099	CHIP RES.	12k	1/16W	5%	RMC1/16 123JATP	J24185123		1-	B	a4
R 1100	CHIP RES.	2.2k	1/16W	5%	RMC1/16 222JATP	J24185222		1-	B	a5
R 1101	CHIP RES.	12k	1/16W	5%	RMC1/16 123JATP	J24185123		1-	B	a5
R 1102	CHIP RES.	12k	1/16W	5%	RMC1/16 123JATP	J24185123		1-	B	a4
R 1103	CHIP RES.	2.2k	1/16W	5%	RMC1/16 222JATP	J24185222		1-	B	a4
R 1104	CHIP RES.	220	1/16W	5%	RMC1/16 221JATP	J24185221		1-	A	F4
R 1105	CHIP RES.	470	1/16W	5%	RMC1/16 471JATP	J24185471		1-	B	a4
R 1106	CHIP RES.	1k	1/16W	5%	RMC1/16 102JATP	J24185102		1-	B	b4
R 1107	CHIP RES.	470	1/16W	5%	RMC1/16 471JATP	J24185471		1-	A	F4
R 1108	CHIP RES.	15	1/16W	5%	RMC1/16 150JATP	J24185150		1-	A	F4
R 1109	CHIP RES.	68	1/16W	5%	RMC1/16 680JATP	J24185680		1-2	A	E4
R 1109	CHIP RES.	68	1/16W	5%	RMC1/16 680JATP	J24185680	VERSION D	3-	A	E4
R 1112	CHIP RES.	0	1/16W	5%	RMC1/16 000JATP	J24185000		1-	A	E3
R 1115	CHIP RES.	56	1/16W	5%	RMC1/16 560JATP	J24185560		1-	A	E4
R 1117	CHIP RES.	1k	1/16W	5%	RMC1/16 102JATP	J24185102		1-	B	a4
R 1119	CHIP RES.	12k	1/16W	5%	RMC1/16 123JATP	J24185123		1-	B	a5



REF.	DESCRIPTION	VALUE	WV	TOL.	MFR'S DESIG	VXSTD P/N	VERS.	LOT.	SIDE.	LAY ADR.
R 1120	CHIP RES.	12k	1/16W	5%	RMC1/16 123JATP	J24185123		1-	B	a4
R 1121	CHIP RES.	12k	1/16W	5%	RMC1/16 123JATP	J24185123		1-	B	a4
R 1123	CHIP RES.	2.2k	1/16W	5%	RMC1/16 222JATP	J24185222		1-	B	a5
R 1124	CHIP RES.	470k	1/16W	5%	RMC1/16 474JATP	J24185474		1-	A	F4
R 1125	CHIP RES.	270k	1/16W	5%	RMC1/16 274JATP	J24185274		1-	A	F5
R 1126	CHIP RES.	47k	1/16W	5%	RMC1/16 473JATP	J24185473		1-	B	b4
R 1127	CHIP RES.	47k	1/16W	5%	RMC1/16 473JATP	J24185473		1-	B	b4
R 1128	CHIP RES.	47k	1/16W	5%	RMC1/16 473JATP	J24185473		1-	B	b4
R 1129	CHIP RES.	47k	1/16W	5%	RMC1/16 473JATP	J24185473		1-	B	b5
R 1130	CHIP RES.	120k	1/16W	5%	RMC1/16 124JATP	J24185124		1-	A	F5
R 1131	CHIP RES.	47k	1/16W	5%	RMC1/16 473JATP	J24185473		1-	A	F5
R 1132	CHIP RES.	470k	1/16W	5%	RMC1/16 474JATP	J24185474		1-	B	b5
R 1133	CHIP RES.	470	1/16W	5%	RMC1/16 471JATP	J24185471		1-	B	b4
R 1134	CHIP RES.	47k	1/16W	5%	RMC1/16 473JATP	J24185473		1-	A	G4
R 1135	CHIP RES.	47k	1/16W	5%	RMC1/16 473JATP	J24185473		1-	A	G4
R 1136	CHIP RES.	2.2k	1/16W	5%	RMC1/16 222JATP	J24185222		1-	A	G4
R 1138	CHIP RES.	2.2k	1/16W	5%	RMC1/16 222JATP	J24185222		1-	A	G4
R 1139	CHIP RES.	220k	1/16W	5%	RMC1/16 224JATP	J24185224		1-	B	a4
R 1140	CHIP RES.	100	1/16W	5%	RMC1/16 101JATP	J24185101		1-	B	a4
R 1141	CHIP RES.	56k	1/16W	5%	RMC1/16 563JATP	J24185563		1-	A	F5
R 1142	CHIP RES.	15k	1/16W	5%	RMC1/16 153JATP	J24185153		1-	A	F5
R 1143	CHIP RES.	220k	1/16W	5%	RMC1/16 224JATP	J24185224		1-	B	a5
R 1144	CHIP RES.	270k	1/16W	5%	RMC1/16 274JATP	J24185274		1-	B	a5
R 1145	CHIP RES.	100	1/16W	5%	RMC1/16 101JATP	J24185101		1-	B	e3
R 1146	CHIP RES.	10k	1/16W	5%	RMC1/16 103JATP	J24185103		1-	B	e3
R 1147	CHIP RES.	10k	1/16W	5%	RMC1/16 103JATP	J24185103		1-	B	e3
R 1148	CHIP RES.	1k	1/16W	5%	RMC1/16 102JATP	J24185102		1-	B	e3
R 1149	CHIP RES.	15	1/16W	5%	RMC1/16 150JATP	J24185150		1-	B	d3
R 1150	CHIP RES.	220	1/16W	5%	RMC1/16 221JATP	J24185221		1-	B	d3
R 1151	CHIP RES.	220	1/16W	5%	RMC1/16 221JATP	J24185221		1-	B	d3
R 1152	CHIP RES.	1k	1/16W	5%	RMC1/16 102JATP	J24185102		1-	B	e2
R 1153	CHIP RES.	2.2k	1/16W	5%	RMC1/16 222JATP	J24185222		1-	B	d2
R 1154	CHIP RES.	68	1/16W	5%	RMC1/16 680JATP	J24185680		1-	A	C3
R 1155	CHIP RES.	22	1/10W	5%	RMC1/10T 220J	J24205220		1-	B	e2
R 1156	CHIP RES.	1k	1/16W	5%	RMC1/16 102JATP	J24185102		1-	B	b4
R 1157	CHIP RES.	270k	1/16W	5%	RMC1/16 274JATP	J24185274		1-	B	c4
R 1158	CHIP RES.	100	1/16W	5%	RMC1/16 101JATP	J24185101		1-	B	b4
R 1159	CHIP RES.	47k	1/16W	5%	RMC1/16 473JATP	J24185473		4-	A	C3
R 1160	CHIP RES.	0	1/16W	5%	RMC1/16 000JATP	J24185000		4-	A	D3
R 2003	CHIP RES.	100k	1/16W	5%	RMC1/16 104JATP	J24185104		1-	B	f4
R 2005	CHIP RES.	100k	1/16W	5%	RMC1/16 104JATP	J24185104		1-	B	f4
R 2006	CHIP RES.	330	1/16W	5%	RMC1/16 331JATP	J24185331		1-	B	g3
R 2007	CHIP RES.	330	1/16W	5%	RMC1/16 331JATP	J24185331		1-	B	g1
R 2008	CHIP RES.	10k	1/16W	5%	RMC1/16 103JATP	J24185103		1-	B	g1
R 2009	CHIP RES.	330	1/16W	5%	RMC1/16 331JATP	J24185331		1-	B	f5
R 2010	CHIP RES.	330	1/16W	5%	RMC1/16 331JATP	J24185331		1-	B	f5
R 2011	CHIP RES.	560	1/16W	5%	RMC1/16 561JATP	J24185561		1-	B	f5
R 2012	CHIP RES.	120k	1/16W	5%	RMC1/16 124JATP	J24185124		1-	B	f5
R 2013	CHIP RES.	2.2k	1/16W	5%	RMC1/16 222JATP	J24185222		1-	B	f5
R 2014	CHIP RES.	680	1/16W	5%	RMC1/16 681JATP	J24185681		1-	A	B5
R 2015	CHIP RES.	47k	1/16W	5%	RMC1/16 473JATP	J24185473		1-	A	B5
R 2018	CHIP RES.	680	1/16W	5%	RMC1/16 681JATP	J24185681		1-	B	f5
R 2019	CHIP RES.	0.33	1W	10%	RMC1 R33KATE	J24309001		1-	A	B2
R 2020	CHIP RES.	150k	1/16W	5%	RMC1/16 154JATP	J24185154		1-	B	f5
R 2022	CARBON FILM RES.	2.2	1/6W	5%	RD16UJ2R2 2.2	J02225229		1-	B	g2
R 2022	CHIP RES.	2.2	1/16W	5%	RMC1/16 2R2JATP	J24185229		4-	B	g2
R 2026	CHIP RES.	100k	1/16W	5%	RMC1/16 104JATP	J24185104		1-	B	f4
R 2028	CHIP RES.	100k	1/16W	5%	RMC1/16 104JATP	J24185104		1-	B	f4
R 2029	CHIP RES.	100k	1/16W	5%	RMC1/16 104JATP	J24185104		1-	A	C4
R 2030	CHIP RES.	10k	1/16W	5%	RMC1/16 103JATP	J24185103		1-	B	g4

# MAIN Unit

REF.	DESCRIPTION	VALUE	WV	TOL.	MFR'S DESIG	VXSTD P/N	VERS.	LOT.	SIDE	LAY ADR.
R 2031	CHIP RES.	10k	1/16W	5%	RMC1/16 103JATP	J24185103		1-	B	g1
R 2032	CHIP RES.	680	1/16W	5%	RMC1/16 681JATP	J24185681		1-	A	A1
R 2033	CHIP RES.	4.7k	1/16W	5%	RMC1/16 472JATP	J24185472		1-	B	g5
R 2034	CHIP RES.	4.7k	1/16W	5%	RMC1/16 472JATP	J24185472		1-	B	g5
R 2035	CHIP RES.	100k	1/16W	5%	RMC1/16 104JATP	J24185104		1-	B	e5
R 2036	CHIP RES.	22k	1/16W	5%	RMC1/16 223JATP	J24185223		1-	B	e5
R 2037	CHIP RES.	120k	1/16W	5%	RMC1/16 124JATP	J24185124		1-	B	e5
R 2038	CHIP RES.	4.7k	1/16W	5%	RMC1/16 472JATP	J24185472		1-	B	f5
R 2039	CHIP RES.	100k	1/16W	5%	RMC1/16 104JATP	J24185104		1-	A	C5
R 2040	CHIP RES.	2.2k	1/16W	5%	RMC1/16 222JATP	J24185222		1-	B	e5
R 2041	CHIP RES.	39k	1/16W	5%	RMC1/16 393JATP	J24185393		1-	B	e5
R 2042	CHIP RES.	220k	1/16W	5%	RMC1/16 224JATP	J24185224		1-	B	g2
R 2043	CHIP RES.	10k	1/16W	5%	RMC1/16 103JATP	J24185103		1-	B	f5
R 2044	CHIP RES.	270k	1/16W	5%	RMC1/16 274JATP	J24185274		1-	B	f5
R 2047	CHIP RES.	470k	1/16W	5%	RMC1/16 474JATP	J24185474		1-3	B	g3
R 2048	CHIP RES.	22k	1/16W	5%	RMC1/16 223JATP	J24185223		1-	A	A3
R 2050	CHIP RES.	2.7k	1/16W	5%	RMC1/16 272JATP	J24185272		1-	B	f2
R 2051	CHIP RES.	47k	1/16W	5%	RMC1/16 473JATP	J24185473		1-	B	g3
R 2051	CHIP RES.	2.2M	1/16W	5%	RMC1/16 225JATP	J24185225		4-	B	g3
R 2052	CHIP RES.	680	1/16W	5%	RMC1/16 681JATP	J24185681		1-	A	A2
R 2053	CHIP RES.	470	1/16W	5%	RMC1/16 471JATP	J24185471		1-	A	C4
R 2054	CHIP RES.	47k	1/16W	5%	RMC1/16 473JATP	J24185473		1-	B	f3
R 2055	CHIP RES.	4.7k	1/16W	5%	RMC1/16 472JATP	J24185472		1-	B	f5
R 2056	CHIP RES.	4.7k	1/16W	5%	RMC1/16 472JATP	J24185472		1-	B	f5
R 2057	CHIP RES.	5.6k	1/16W	5%	RMC1/16 562JATP	J24185562		1-	A	B5
R 2058	CHIP RES.	10k	1/16W	5%	RMC1/16 103JATP	J24185103		1-	B	e4
R 2059	CHIP RES.	22k	1/16W	5%	RMC1/16 223JATP	J24185223		1-	B	e5
R 2060	CHIP RES.	10k	1/16W	5%	RMC1/16 103JATP	J24185103		1-	A	C5
R 2061	CHIP RES.	100k	1/16W	5%	RMC1/16 104JATP	J24185104		1-	B	e5
R 2062	CHIP RES.	0	1/16W	5%	RMC1/16 000JATP	J24185000		1-	B	f3
R 2063	CHIP RES.	10k	1/16W	5%	RMC1/16 103JATP	J24185103		1-	B	e4
R 2064	CHIP RES.	15k	1/16W	5%	RMC1/16 153JATP	J24185153		1-	B	e4
R 2065	CHIP RES.	1k	1/16W	5%	RMC1/16 102JATP	J24185102		1-	A	A3
R 2066	CHIP RES.	10k	1/16W	5%	RMC1/16 103JATP	J24185103		1-	B	g3
R 2067	CHIP RES.	10k	1/16W	5%	RMC1/16 103JATP	J24185103		1-	B	g3
R 2068	CHIP RES.	47	1/16W	5%	RMC1/16 470JATP	J24185470		1-	A	D4
R 2069	CHIP RES.	47k	1/16W	5%	RMC1/16 473JATP	J24185473		1-	B	d4
R 2070	CHIP RES.	10k	1/16W	5%	RMC1/16 103JATP	J24185103		1-	A	D4
R 2071	CHIP RES.	10k	1/16W	5%	RMC1/16 103JATP	J24185103		1-	A	D4
R 2072	CHIP RES.	220k	1/16W	5%	RMC1/16 224JATP	J24185224		1-	A	C5
R 2073	CHIP RES.	100k	1/16W	5%	RMC1/16 104JATP	J24185104		1-	A	C5
R 2074	CHIP RES.	150k	1/16W	5%	RMC1/16 154JATP	J24185154		1-	B	d5
R 2075	CHIP RES.	1M	1/16W	5%	RMC1/16 105JATP	J24185105		1-	B	d4
R 2076	CHIP RES.	150k	1/16W	5%	RMC1/16 154JATP	J24185154		1-	B	d4
R 2077	CHIP RES.	1M	1/16W	5%	RMC1/16 105JATP	J24185105		1-	A	C5
R 2078	CHIP RES.	1M	1/16W	5%	RMC1/16 105JATP	J24185105		1-	A	C4
R 2079	CHIP RES.	47k	1/16W	5%	RMC1/16 473JATP	J24185473		1-	A	D5
R 2080	CHIP RES.	2.2k	1/16W	5%	RMC1/16 222JATP	J24185222		1-	A	D4
R 2081	CHIP RES.	3.3k	1/16W	5%	RMC1/16 332JATP	J24185332		1-	B	d4
R 2082	CHIP RES.	10k	1/16W	5%	RMC1/16 103JATP	J24185103		1-	B	d4
R 2083	CHIP RES.	47	1/16W	5%	RMC1/16 470JATP	J24185470		1-	B	e3
R 2084	CHIP RES.	10k	1/16W	5%	RMC1/16 103JATP	J24185103		1-	A	B4
R 2085	CHIP RES.	22k	1/16W	5%	RMC1/16 223JATP	J24185223		1-	A	B4
R 2086	CHIP RES.	18k	1/16W	5%	RMC1/16 183JATP	J24185183		1-	A	B4
R 2087	CHIP RES.	39k	1/16W	5%	RMC1/16 393JATP	J24185393		1-	A	B4
R 2088	CHIP RES.	10k	1/16W	5%	RMC1/16 103JATP	J24185103		1-	A	B4
R 2089	CHIP RES.	15k	1/16W	5%	RMC1/16 153JATP	J24185153		1-	A	C5
R 2090	CHIP RES.	12k	1/16W	5%	RMC1/16 123JATP	J24185123		1-	A	C5
R 2091	CHIP RES.	39k	1/16W	5%	RMC1/16 393JATP	J24185393		1-	B	e5
R 2092	CHIP RES.	680k	1/16W	5%	RMC1/16 684JATP	J24185684		1-	B	e5

REF.	DESCRIPTION	VALUE	WV	TOL.	MFR'S DESIG	VXSTD P/N	VERS.	LOT.	SIDE.	LAY ADR.
R 2093	CHIP RES.	10k	1/16W	5%	RMC1/16 103JATP	J24185103		1-	A	C5
R 2094	CHIP RES.	39k	1/16W	5%	RMC1/16 393JATP	J24185393		1-	A	D4
R 2095	CHIP RES.	330k	1/16W	5%	RMC1/16 334JATP	J24185334		1-	B	d5
R 2096	CHIP RES.	2.2M	1/16W	5%	RMC1/16 225JATP	J24185225		1-	B	d5
R 2097	CHIP RES.	5.6k	1/16W	5%	RMC1/16 562JATP	J24185562		1-	A	D5
R 2098	CHIP RES.	470k	1/16W	5%	RMC1/16 474JATP	J24185474		1-	B	d4
R 2099	CHIP RES.	150k	1/16W	5%	RMC1/16 154JATP	J24185154		1-	B	d4
R 2100	CHIP RES.	180k	1/16W	5%	RMC1/16 184JATP	J24185184		1-	B	d5
R 2101	CHIP RES.	180k	1/16W	5%	RMC1/16 184JATP	J24185184		1-	B	d4
R 2102	CHIP RES.	15k	1/16W	5%	RMC1/16 153JATP	J24185153		1-	A	D4
R 2103	CHIP RES.	12k	1/16W	5%	RMC1/16 123JATP	J24185123		1-	A	D4
R 2104	CHIP RES.	150k	1/16W	5%	RMC1/16 154JATP	J24185154		1-	B	d4
R 2105	CHIP RES.	0	1/16W	5%	RMC1/16 000JATP	J24185000		1-	B	d4
R 2106	CHIP RES.	180	1/16W	5%	RMC1/16 181JATP	J24185181		1-	A	D4
R 2107	CHIP RES.	2.2k	1/16W	5%	RMC1/16 222JATP	J24185222		1-	B	d4
R 2108	CHIP RES.	0	1/16W	5%	RMC1/16 000JATP	J24185000		1-	A	D4
R 2109	CHIP RES.	150k	1/16W	5%	RMC1/16 154JATP	J24185154		1-	B	d4
R 2110	CHIP RES.	10k	1/16W	5%	RMC1/16 103JATP	J24185103		1-	B	d4
R 2111	CHIP RES.	2.2M	1/16W	5%	RMC1/16 225JATP	J24185225		1-	A	C4
R 2112	CHIP RES.	330k	1/16W	5%	RMC1/16 334JATP	J24185334		1-	A	C4
R 2113	CHIP RES.	10k	1/16W	5%	RMC1/16 103JATP	J24185103		1-	A	D4
R 2114	CHIP RES.	82k	1/16W	5%	RMC1/16 823JATP	J24185823		1-	A	C5
R 2115	CHIP RES.	10k	1/16W	5%	RMC1/16 103JATP	J24185103		1-	A	C5
R 2116	CHIP RES.	18k	1/16W	5%	RMC1/16 183JATP	J24185183		1-	A	C5
R 2117	CHIP RES.	12k	1/16W	5%	RMC1/16 123JATP	J24185123		1-	A	D5
R 2118	CHIP RES.	820k	1/16W	5%	RMC1/16 824JATP	J24185824		1-	A	C5
R 2119	CHIP RES.	680k	1/16W	5%	RMC1/16 684JATP	J24185684		1-	B	e5
R 2120	CHIP RES.	1.2k	1/16W	5%	RMC1/16 122JATP	J24185122		1-	B	e5
R 2121	CHIP RES.	15k	1/16W	5%	RMC1/16 153JATP	J24185153		1-	B	e4
R 2122	CHIP RES.	470k	1/16W	5%	RMC1/16 474JATP	J24185474		1-	B	e5
R 2123	CHIP RES.	470k	1/16W	5%	RMC1/16 474JATP	J24185474		1-	B	d5
R 2124	CHIP RES.	330k	1/16W	5%	RMC1/16 334JATP	J24185334		1-	B	d5
R 2125	CHIP RES.	330k	1/16W	5%	RMC1/16 334JATP	J24185334		1-	B	d5
R 2126	CHIP RES.	1M	1/16W	5%	RMC1/16 105JATP	J24185105		1-	B	d5
R 2127	CHIP RES.	330k	1/16W	5%	RMC1/16 334JATP	J24185334		1-	B	d5
R 2128	CHIP RES.	1M	1/16W	5%	RMC1/16 105JATP	J24185105		1-	B	g4
R 2129	CHIP RES.	180k	1/16W	5%	RMC1/16 184JATP	J24185184		1-	B	d5
R 2130	CHIP RES.	1k	1/16W	5%	RMC1/16 102JATP	J24185102		1-	B	d4
R 2131	CHIP RES.	180	1/16W	5%	RMC1/16 181JATP	J24185181		1-	B	d4
R 2133	CHIP RES.	47k	1/16W	5%	RMC1/16 473JATP	J24185473		1-	B	f4
R 2134	CHIP RES.	10k	1/16W	5%	RMC1/16 103JATP	J24185103		1-	A	D4
R 2135	CHIP RES.	680k	1/16W	5%	RMC1/16 684JATP	J24185684		1-	B	d4
R 2136	CHIP RES.	180k	1/16W	5%	RMC1/16 184JATP	J24185184		1-	B	d4
R 2137	CHIP RES.	100k	1/16W	5%	RMC1/16 104JATP	J24185104		1-	B	d4
R 2138	CHIP RES.	6.8k	1/16W	5%	RMC1/16 682JATP	J24185682		1-	B	d4
R 2139	CHIP RES.	1.5M	1/16W	5%	RMC1/16 155JATP	J24185155		1-	A	D4
R 2140	CHIP RES.	10k	1/16W	5%	RMC1/16 103JATP	J24185103		1-	A	C4
R 2141	CHIP RES.	180k	1/16W	5%	RMC1/16 184JATP	J24185184		1-	A	C3
R 2142	CHIP RES.	100k	1/16W	5%	RMC1/16 104JATP	J24185104		1-	B	e5
R 2143	CHIP RES.	120k	1/16W	5%	RMC1/16 124JATP	J24185124		1-	B	e5
R 2144	CHIP RES.	120k	1/16W	5%	RMC1/16 124JATP	J24185124		1-	B	e5
R 2145	CHIP RES.	10k	1/16W	5%	RMC1/16 103JATP	J24185103		1-	B	d4
R 2146	CHIP RES.	330k	1/16W	5%	RMC1/16 334JATP	J24185334		1-	B	d5
R 2147	CHIP RES.	10k	1/16W	5%	RMC1/16 103JATP	J24185103		1-	B	d4
R 2149	CHIP RES.	15k	1/16W	5%	RMC1/16 153JATP	J24185153		1-	A	A4
R 2150	CHIP RES.	47k	1/16W	5%	RMC1/16 473JATP	J24185473		1-	A	A3
R 2151	CHIP RES.	47k	1/16W	5%	RMC1/16 473JATP	J24185473		1-	B	g4
R 2152	CHIP RES.	47k	1/16W	5%	RMC1/16 473JATP	J24185473		1-	B	f4
R 2153	CHIP RES.	47k	1/16W	5%	RMC1/16 473JATP	J24185473		1-	B	f4
R 2154	CHIP RES.	10k	1/16W	5%	RMC1/16 103JATP	J24185103		1-	B	d5

# MAIN Unit

REF.	DESCRIPTION	VALUE	WV	TOL.	MFR'S DESIG	VXSTD P/N	VERS.	LOT.	SIDE	LAY ADR.
R 2155	CHIP RES.	100k	1/16W	5%	RMC1/16 104JATP	J24185104		1-	B	d5
R 2156	CHIP RES.	120k	1/16W	5%	RMC1/16 124JATP	J24185124		1-	B	d5
R 2157	CHIP RES.	10k	1/16W	5%	RMC1/16 103JATP	J24185103		1-	B	e4
R 2158	CHIP RES.	10k	1/16W	5%	RMC1/16 103JATP	J24185103		1-	B	e4
R 2159	CHIP RES.	10k	1/16W	5%	RMC1/16 103JATP	J24185103		1-	B	e4
R 2160	CHIP RES.	47k	1/16W	5%	RMC1/16 473JATP	J24185473		1-	B	f2
R 2162	CHIP RES.	1k	1/16W	5%	RMC1/16 102JATP	J24185102		1-	B	f2
R 2166	CHIP RES.	0	1/16W	5%	RMC1/16 000JATP	J24185000		1-	A	D5
R 2168	CHIP RES.	10k	1/16W	5%	RMC1/16 103JATP	J24185103		1-	B	g4
R 2169	CHIP RES.	10k	1/16W	5%	RMC1/16 103JATP	J24185103		1-	A	D5
R 2170	CHIP RES.	33k	1/16W	5%	RMC1/16 333JATP	J24185333		1-	B	d5
R 2171	CHIP RES.	10k	1/16W	5%	RMC1/16 103JATP	J24185103		1-	B	d5
R 2172	CHIP RES.	22k	1/16W	5%	RMC1/16 223JATP	J24185223		1-	B	d5
R 2175	CHIP RES.	15k	1/16W	5%	RMC1/16 153JATP	J24185153		1-	B	f2
R 2176	CHIP RES.	220k	1/16W	5%	RMC1/16 224JATP	J24185224		1-	B	f2
R 2177	CHIP RES.	15k	1/16W	5%	RMC1/16 153JATP	J24185153		1-	B	f2
R 2178	CHIP RES.	47k	1/16W	5%	RMC1/16 473JATP	J24185473		1-	B	f2
R 2179	CHIP RES.	10k	1/16W	5%	RMC1/16 103JATP	J24185103		1-	A	A3
R 2180	CHIP RES.	47k	1/16W	5%	RMC1/16 473JATP	J24185473		1-	B	f3
R 2182	CHIP RES.	47k	1/16W	5%	RMC1/16 473JATP	J24185473		1-	B	f3
R 2183	CHIP RES.	330k	1/16W	5%	RMC1/16 334JATP	J24185334		1-	B	g4
R 2184	CHIP RES.	10k	1/16W	5%	RMC1/16 103JATP	J24185103		1-	B	g4
R 2185	CHIP RES.	100k	1/16W	5%	RMC1/16 104JATP	J24185104		1-	B	g4
R 2187	CHIP RES.	120k	1/16W	5%	RMC1/16 124JATP	J24185124		1-	A	D5
R 2188	CHIP RES.	56k	1/16W	5%	RMC1/16 563JATP	J24185563		1-	B	d5
R 2189	CHIP RES.	47k	1/16W	5%	RMC1/16 473JATP	J24185473		1-	A	D5
R 2190	CHIP RES.	150k	1/16W	5%	RMC1/16 154JATP	J24185154		1-	B	d5
R 2191	CHIP RES.	47k	1/16W	5%	RMC1/16 473JATP	J24185473		1-	B	f2
R 2192	CHIP RES.	47k	1/16W	5%	RMC1/16 473JATP	J24185473		1-	B	f2
R 2193	CHIP RES.	47k	1/16W	5%	RMC1/16 473JATP	J24185473		1-	B	f3
R 2195	CHIP RES.	10k	1/16W	5%	RMC1/16 103JATP	J24185103		1-	B	f5
R 2196	CHIP RES.	1k	1/16W	5%	RMC1/16 102JATP	J24185102		1-	A	B3
R 2197	CHIP RES.	33k	1/16W	5%	RMC1/16 333JATP	J24185333		1-	B	g3
R 2198	CHIP RES.	10k	1/16W	5%	RMC1/16 103JATP	J24185103		1-	A	A4
R 2200	CHIP RES.	10k	1/16W	5%	RMC1/16 103JATP	J24185103		1-	B	d5
R 2201	CHIP RES.	10k	1/16W	5%	RMC1/16 103JATP	J24185103		1-	B	f2
R 2202	CHIP RES.	4.7k	1/16W	5%	RMC1/16 472JATP	J24185472		1-	B	f3
R 2203	CHIP RES.	22k	1/16W	5%	RMC1/16 223JATP	J24185223		1-	A	B3
R 2204	CHIP RES.	1k	1/16W	5%	RMC1/16 102JATP	J24185102		1-	A	B4
R 2205	CHIP RES.	470	1/16W	5%	RMC1/16 471JATP	J24185471		1-	B	f5
R 2206	CHIP RES.	4.7k	1/16W	5%	RMC1/16 472JATP	J24185472		1-	B	f5
R 2208	CHIP RES.	330	1/16W	5%	RMC1/16 331JATP	J24185331		1-	B	f1
R 2209	CHIP RES.	470	1/16W	5%	RMC1/16 471JATP	J24185471		1-	B	d4
R 2210	CHIP RES.	10k	1/16W	5%	RMC1/16 103JATP	J24185103		1-	B	d4
R 2211	CHIP RES.	10k	1/16W	5%	RMC1/16 103JATP	J24185103		1-	B	f5
R 2212	CHIP RES.	10k	1/16W	5%	RMC1/16 103JATP	J24185103		1-	B	g4
R 2213	CHIP RES.	2.2k	1/16W	5%	RMC1/16 222JATP	J24185222		1-	B	f5
R 2214	CHIP RES.	4.7k	1/16W	5%	RMC1/16 472JATP	J24185472		1-	B	f5
R 2215	CHIP RES.	4.7k	1/16W	5%	RMC1/16 472JATP	J24185472		1-	B	f5
R 2216	CHIP RES.	4.7k	1/16W	5%	RMC1/16 472JATP	J24185472		1-	B	g5
R 2217	CHIP RES.	4.7k	1/16W	5%	RMC1/16 472JATP	J24185472		1-	B	g5
R 2218	CHIP RES.	4.7k	1/16W	5%	RMC1/16 472JATP	J24185472		1-	B	f5
R 2219	CHIP RES.	1M	1/16W	5%	RMC1/16 105JATP	J24185105		1-	A	C5
R 2221	CHIP RES.	10k	1/16W	5%	RMC1/16 103JATP	J24185103		1-	A	B5
R 2222	CHIP RES.	47k	1/16W	5%	RMC1/16 473JATP	J24185473		1-	A	B5
R 2223	CHIP RES.	10k	1/16W	5%	RMC1/16 103JATP	J24185103		1-	A	C4
R 2224	CHIP RES.	4.7k	1/16W	5%	RMC1/16 472JATP	J24185472		1-	B	d4
R 2227	CHIP RES.	0.33	1W	10%	RMC1 R33KATE	J24309001		1-	A	B2
R 2229	CHIP RES.	1k	1/16W	5%	RMC1/16 102JATP	J24185102		1-	B	f1
R 2230	CHIP RES.	1k	1/16W	5%	RMC1/16 102JATP	J24185102		1-	B	f1

REF.	DESCRIPTION	VALUE	WV	TOL.	MFR'S DESIG	VXSTD P/N	VERS.	LOT.	SIDE	LAY ADR.
R 2231	CHIP RES.	1k	1/16W	5%	RMC1/16 102JATP	J24185102		1-	B	f1
R 2232	CHIP RES.	1k	1/16W	5%	RMC1/16 102JATP	J24185102		1-	B	f1
R 2234	CHIP RES.	1k	1/16W	5%	RMC1/16 102JATP	J24185102		1-	B	f1
R 2235	CHIP RES.	1k	1/16W	5%	RMC1/16 102JATP	J24185102		1-	B	g1
R 2236	CHIP RES.	1k	1/16W	5%	RMC1/16 102JATP	J24185102		1-	B	g1
R 2237	CHIP RES.	1k	1/16W	5%	RMC1/16 102JATP	J24185102		1-	B	g1
R 2238	CHIP RES.	1k	1/16W	5%	RMC1/16 102JATP	J24185102		1-	B	g1
R 2240	CHIP RES.	1k	1/16W	5%	RMC1/16 102JATP	J24185102		1-	B	g1
R 2241	CHIP RES.	1k	1/16W	5%	RMC1/16 102JATP	J24185102		1-	B	g1
R 2242	CHIP RES.	1k	1/16W	5%	RMC1/16 102JATP	J24185102		1-	B	g1
R 2243	CHIP RES.	1k	1/16W	5%	RMC1/16 102JATP	J24185102		1-9	B	f1
R 2244	CHIP RES.	1k	1/16W	5%	RMC1/16 102JATP	J24185102		1-	B	f1
R 2245	CHIP RES.	180k	1/16W	5%	RMC1/16 184JATP	J24185184		1-	B	f2
R 2246	CHIP RES.	47k	1/16W	5%	RMC1/16 473JATP	J24185473		1-	A	B4
R 2247	CHIP RES.	10	1/4W	5%	RMC1/4 100JATP	J24245100		1-	B	f2
R 2248	CHIP RES.	15k	1/16W	5%	RMC1/16 153JATP	J24185153		1-	A	C5
R 2249	CHIP RES.	4.7k	1/16W	5%	RMC1/16 472JATP	J24185472		1-	A	C5
R 2250	CHIP RES.	1.5k	1/16W	5%	RMC1/16 152JATP	J24185152		1-	A	D5
R 2251	CHIP RES.	1.5k	1/16W	5%	RMC1/16 152JATP	J24185152		1-	A	D5
R 2254	CHIP RES.	0	1/16W	5%	RMC1/16 000JATP	J24185000		1-	B	g1
R 2255	CHIP RES.	0	1/16W	5%	RMC1/16 000JATP	J24185000		1-	B	g1
R 2256	CHIP RES.	470	1/16W	5%	RMC1/16 471JATP	J24185471		1-	B	f1
R 2257	CHIP RES.	0	1/16W	5%	RMC1/16 000JATP	J24185000		1-	B	f1
R 2258	CHIP RES.	0	1/16W	5%	RMC1/16 000JATP	J24185000		1-	B	g1
R 2259	CHIP RES.	0	1/16W	5%	RMC1/16 000JATP	J24185000		1-	B	f1
R 2260	CHIP RES.	47k	1/16W	5%	RMC1/16 473JATP	J24185473		1-	B	g4
R 2261	CHIP RES.	47k	1/16W	5%	RMC1/16 473JATP	J24185473		1-	B	f4
R 2262	CHIP RES.	10k	1/16W	5%	RMC1/16 103JATP	J24185103		1-	B	g3
R 2262	CHIP RES.	470k	1/16W	5%	RMC1/16 474JATP	J24185474		4-	B	g3
R 2263	CARBON FILM RES.	47k	1/6W	5%	RD16PJ473 47K	J01225473		1-	B	f4
R 2263	CHIP RES.	47k	1/16W	5%	RMC1/16 473JATP	J24185473		4-	B	f4
R 2264	CARBON FILM RES.	2.2	1/6W	5%	RD16UJ2R2 2.2	J02225229		1-	B	g3
R 2264	CHIP RES.	2.2	1/16W	5%	RMC1/16 2R2JATP	J24185229		4-	B	g3
R 2265	CHIP RES.	4.7k	1/16W	5%	RMC1/16 472JATP	J24185472		4-	A	A5
R 2266	CHIP RES.	10k	1/16W	5%	RMC1/16 103JATP	J24185103		4-	B	e4
R 2267	CHIP RES.	4.7k	1/16W	5%	RMC1/16 472JATP	J24185472		4-	A	B5
R 2268	CARBON FILM RES.	10k	1/6W	5%	RD16PJ103 10K	J01225103		1-		
R 2269	CHIP RES.	1M	1/10W	5%	RMC1/10T 105J	J24205105		2-		
TC1001	TRIMMER CAP.	10pF			ECR-JA010A11X	K91000227		1-	A	F4
TH1002	THERMISTOR				TBPS1R473K475H5Q	G9090068		1-	A	F5
TH1003	THERMISTOR				TBPS1R103K440H5Q	G9090067		1-	A	F5
TH2002	THERMISTOR				TBPS1R104K475H5Q	G9090069		1-	B	a2
X 1001	XTAL TOP-B	14.5MHz			14.5MHZ	H0103196		1-	A	F5
X 2001	XTAL 92SMX(A)	16MHz			16.000MHZ	H0103252		1-	A	A4
XF1001	XTAL FILTER				43Y12B5F	H1102307		1-	A	F4
XF1002	XTAL FILTER				43Y12B5F	H1102307		1-	A	F4
	SHIELD CASE				(A)	RA00739A0		5-		
	SHIELD CASE					RA0014200		5-		
	LEAF SPRING					R0140031		5-		
	CU TAPE					RA0375700		5-		

# ***MAIN Unit***

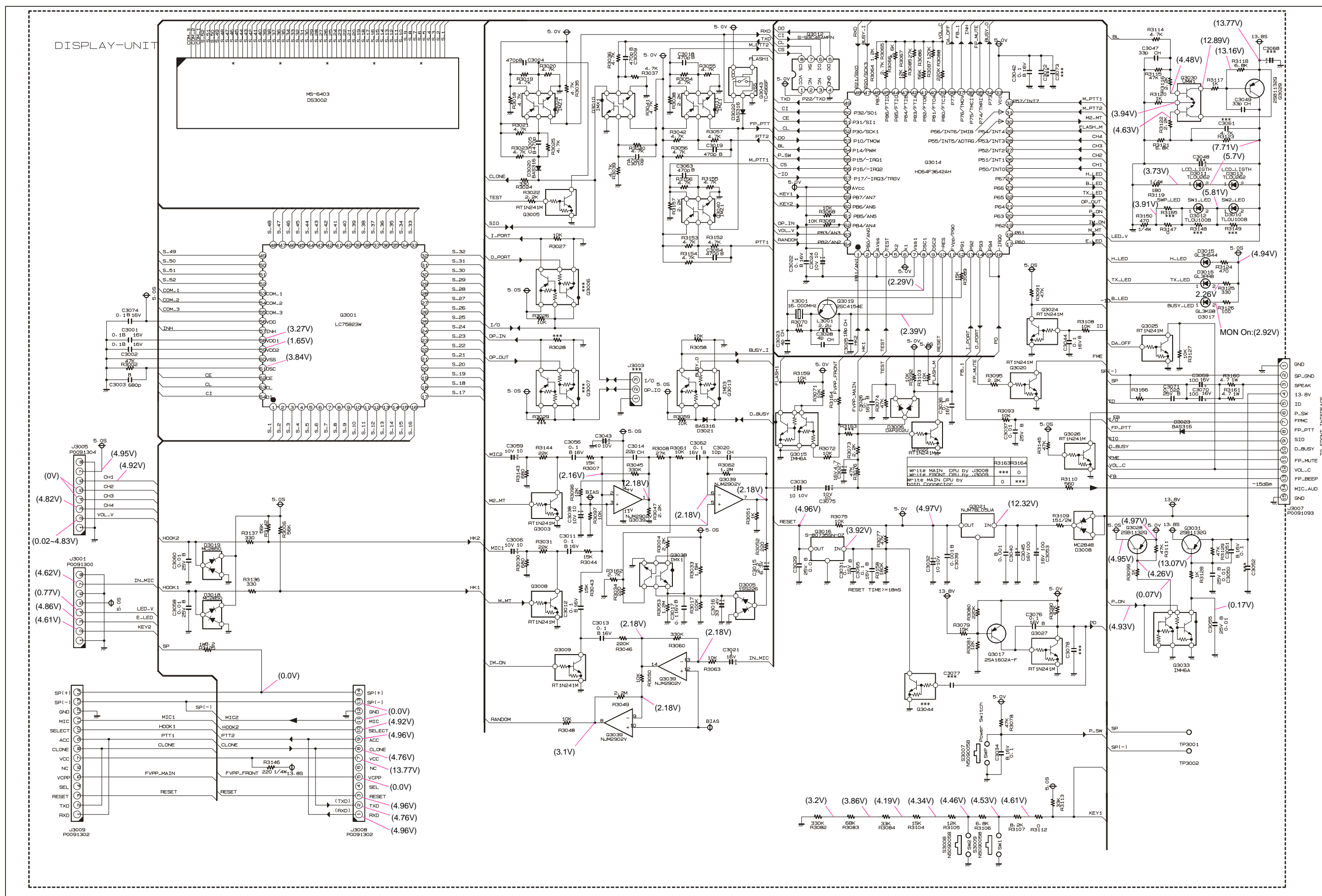

***DISPLAY Unit (Lot. 1~)***

***Note:***



Parts Layout

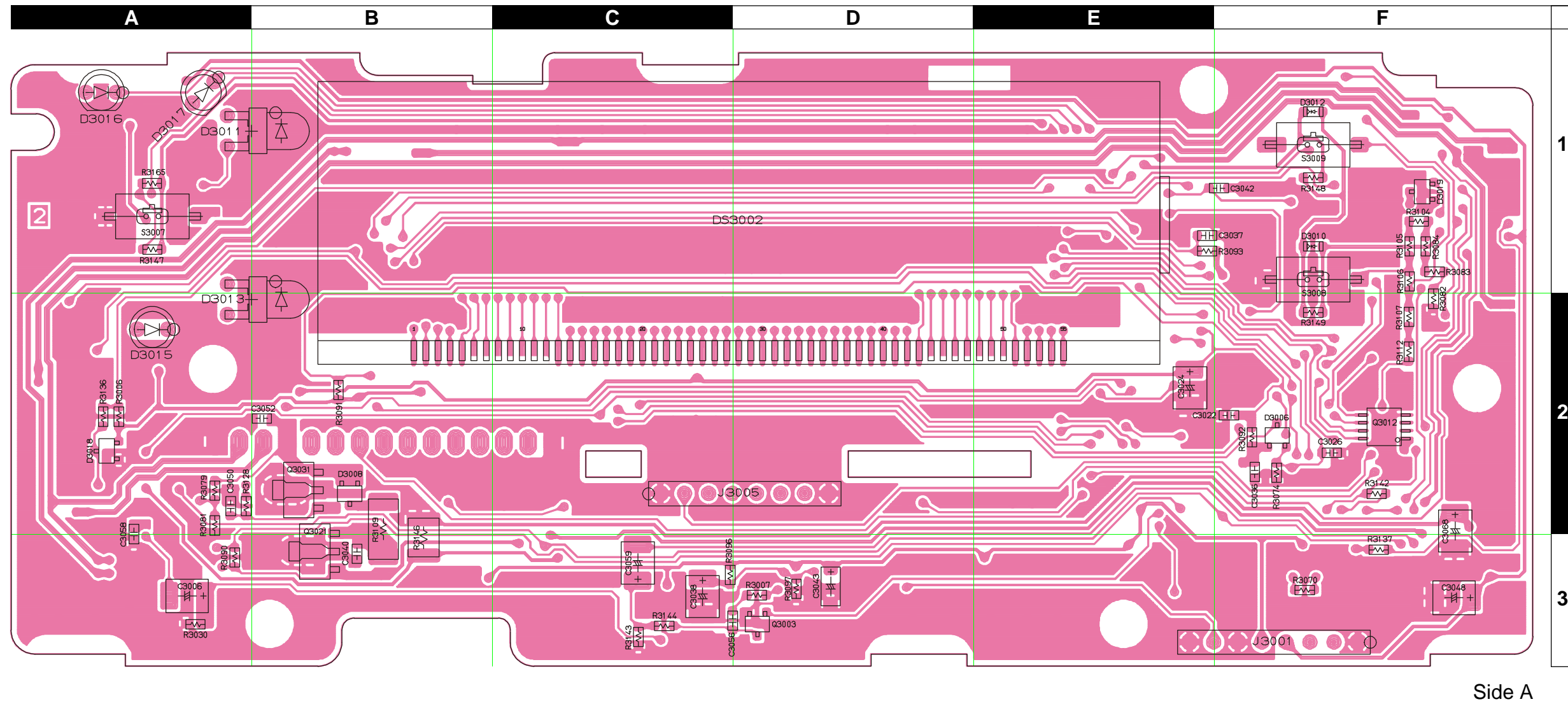

Side A

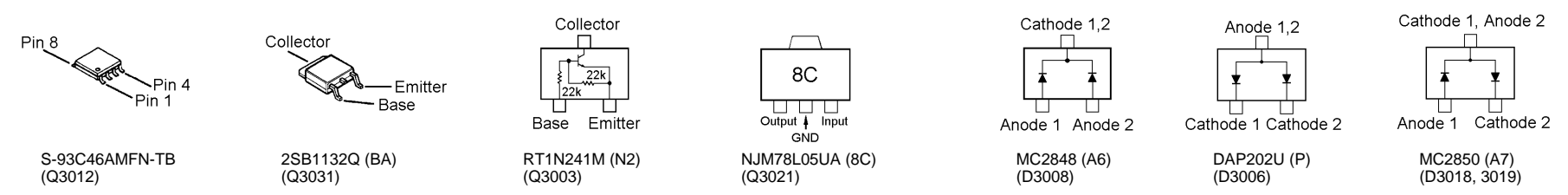

# DISPLAY Unit (Lot. 1~)

## Parts Layout

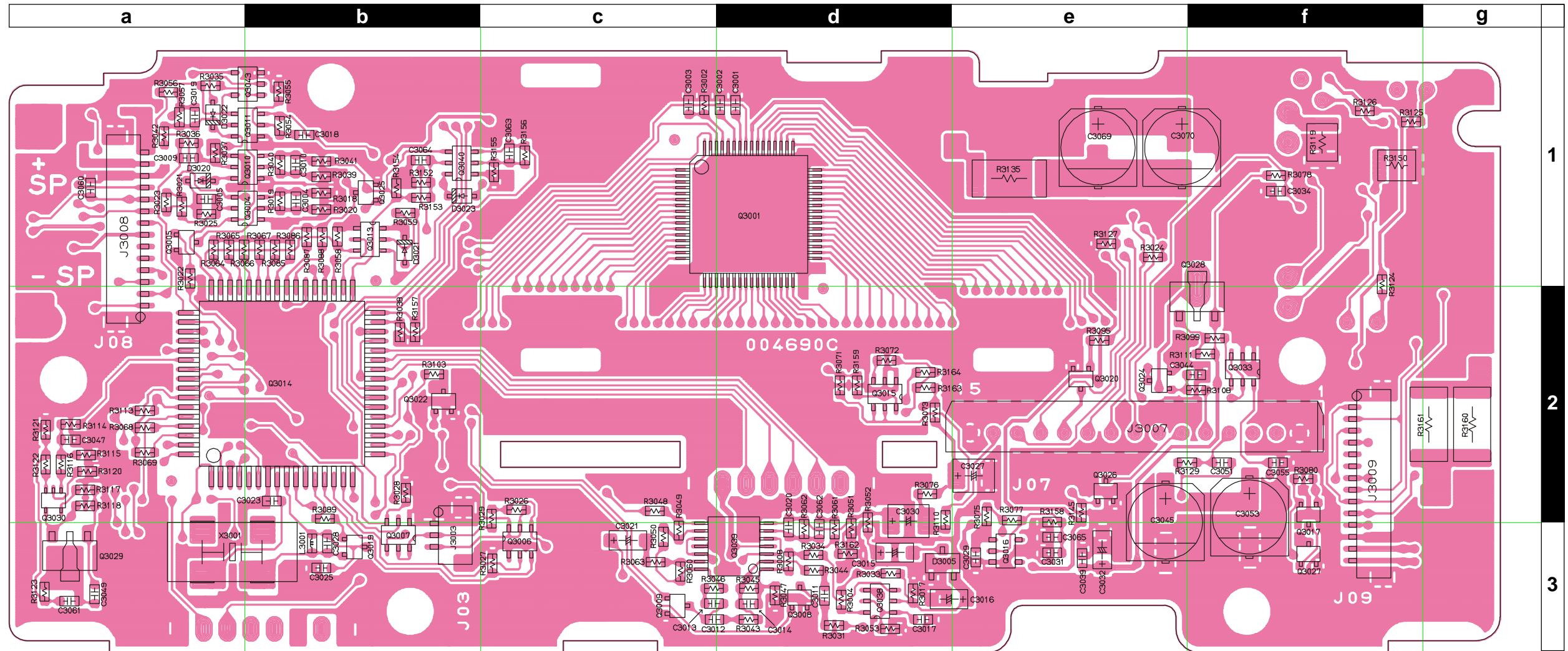

Side B

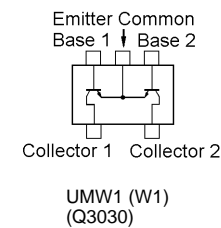
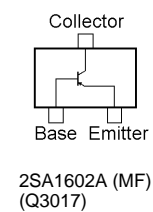
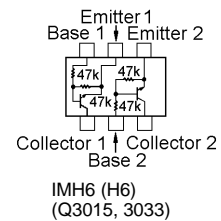
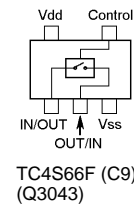
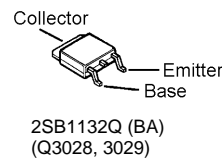
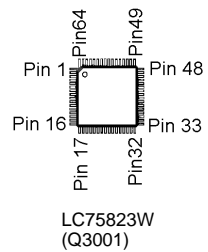
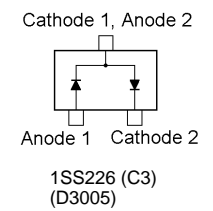
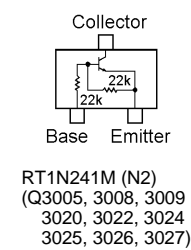
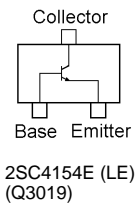
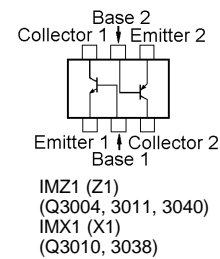
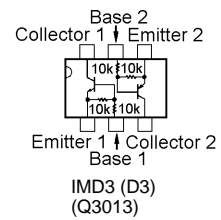
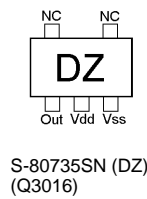
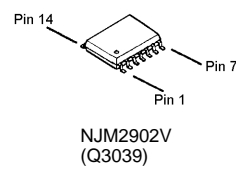
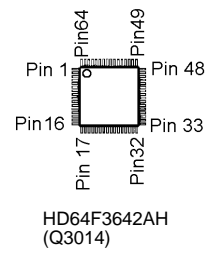

Circuit Diagram

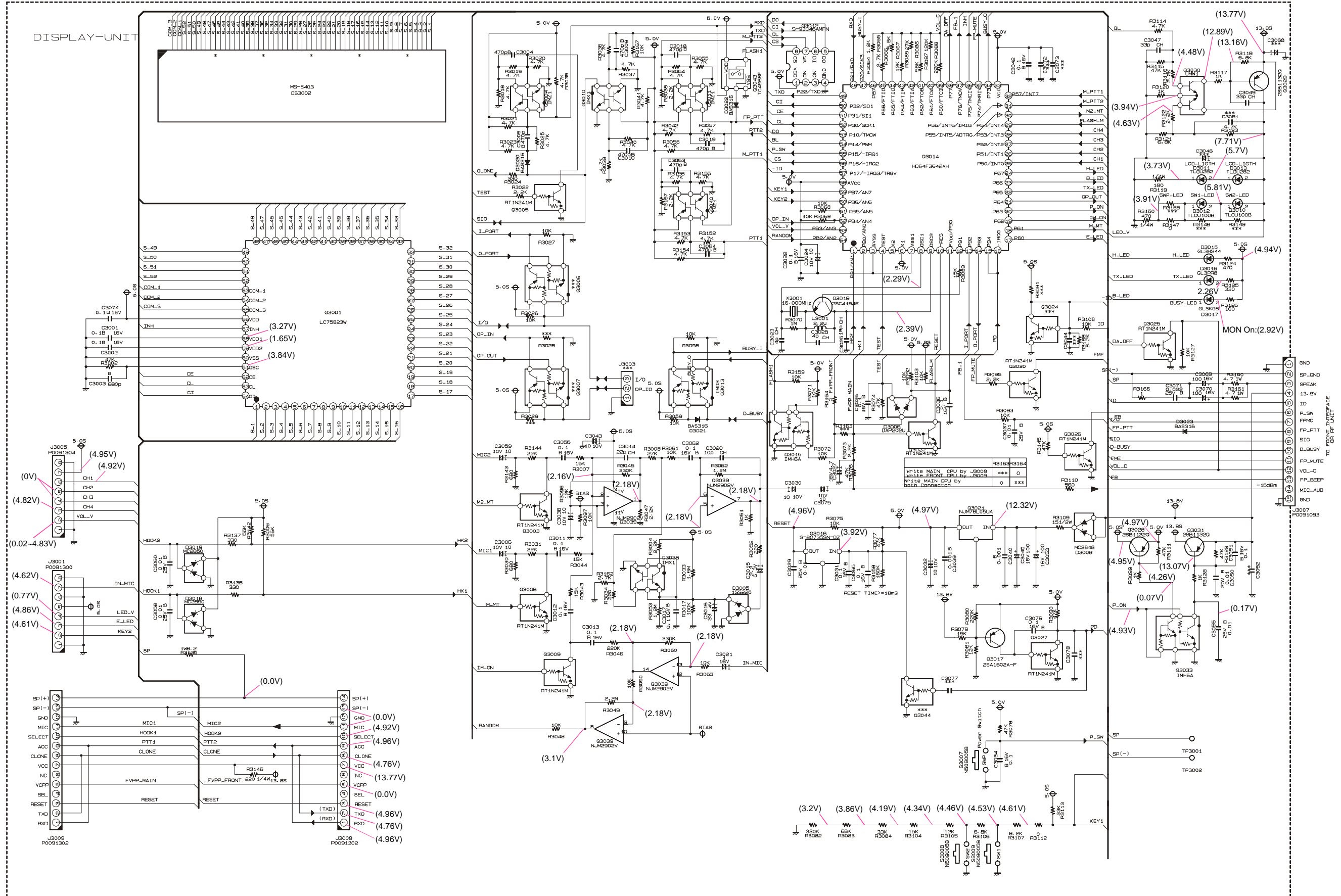

## ***DISPLAY Unit (Lot. 3~)***

***Note:***

Parts Layout

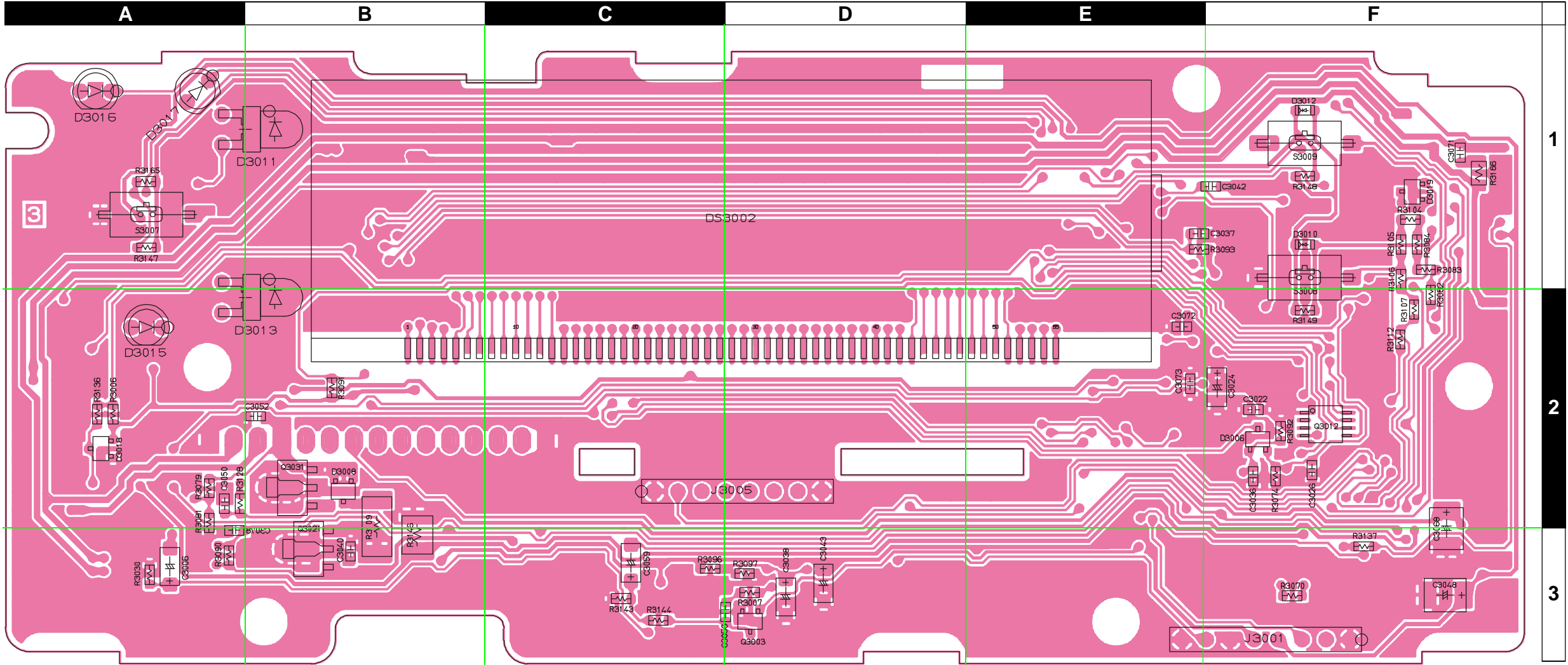

Side A

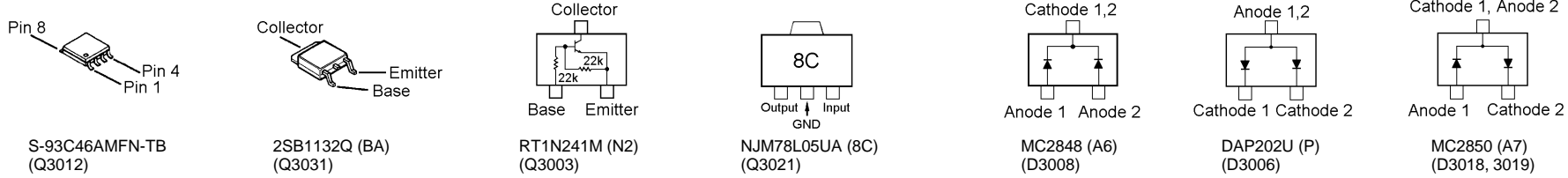

# DISPLAY Unit (Lot. 3~)

## Parts Layout

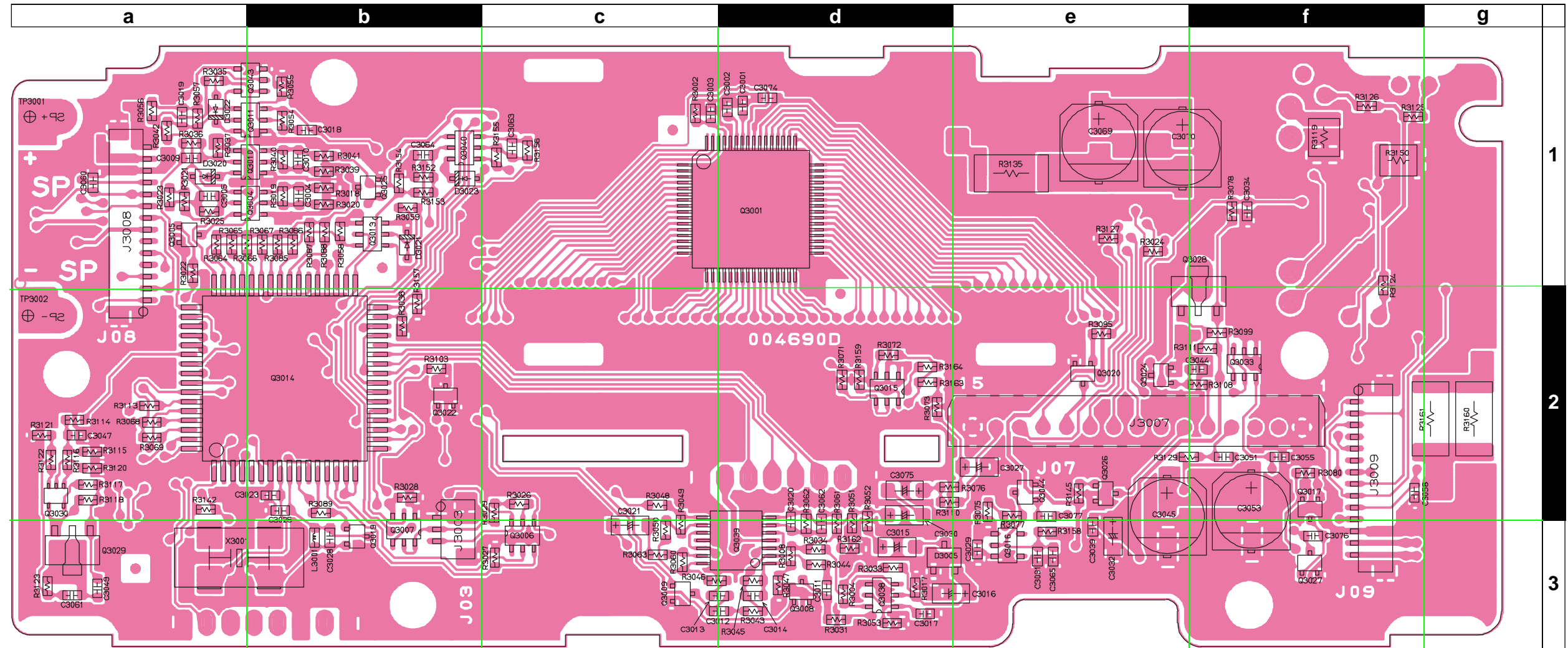

Side B

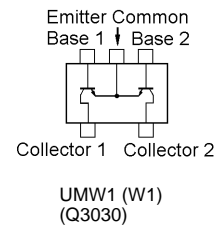
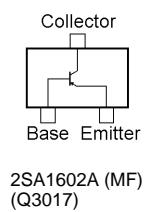
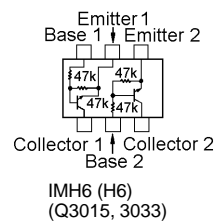
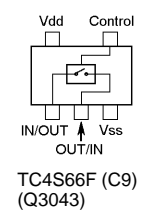
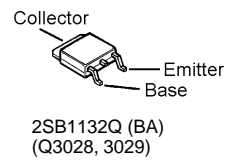
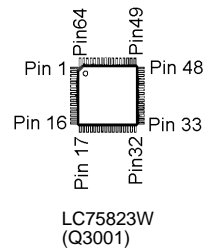
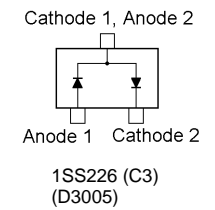
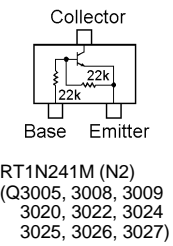
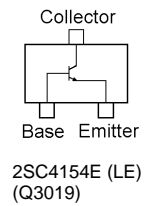
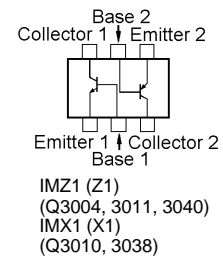
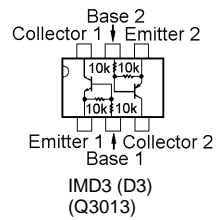
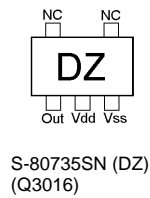
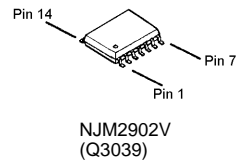
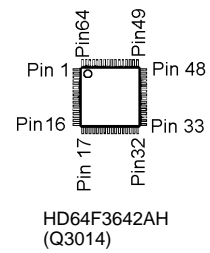

## Parts List

REF.	DESCRIPTION	VALUE	WV	TOL.	MFR'S DESIG	VXSTD P/N	VERS.	LOT.	SIDE	LAY ADR.
*** DISPLAY UNIT ***										
PCB with Components						CB1090001				
Printed Circuit Board						FR004690C		1-		
Printed Circuit Board						FR004690D		3-		
C 3001	CHIP CAP.	0.1uF	16V	B	GRM39B104K16PT	K22124805		1-	B	d1
C 3002	CHIP CAP.	0.1uF	16V	B	GRM39B104K16PT	K22124805		1-	B	d1
C 3003	CHIP CAP.	680pF	50V	B	GRM39B681M50PT	K22174807		1-	B	c1
C 3004	CHIP CAP.	470pF	50V	B	GRM39B471M50PT	K22174805		1-	B	b1
C 3005	CHIP CAP.	470pF	50V	B	GRM39B471M50PT	K22174805		1-	B	a1
C 3006	CHIP TA.CAP.	4.7uF	16V		TEMSVB21C475M-8R	K78120016		1-	A	A3
C 3006	CHIP TA.CAP.	10uF	10V		TEMSVA1A106M-8R	K78100028		3-	A	A3
C 3009	CHIP CAP.	470pF	50V	B	GRM39B471M50PT	K22174805		1-	B	a1
C 3010	CHIP CAP.	470pF	50V	B	GRM39B471M50PT	K22174805		1-	B	b1
C 3011	CHIP CAP.	0.1uF	16V	B	GRM39B104K16PT	K22124805		1-	B	d3
C 3012	CHIP CAP.	0.1uF	16V	B	GRM39B104K16PT	K22124805		1-	B	d3
C 3013	CHIP CAP.	0.1uF	16V	B	GRM39B104K16PT	K22124805		1-	B	d3
C 3014	CHIP CAP.	22pF	50V	CH	GRM39CH220J50PT	K22174219		1-	B	d3
C 3015	CHIP TA.CAP.	2.2uF	6.3V		TESVA0J225M1-8R	K78080009		1-	B	d3
C 3016	CHIP TA.CAP.	33uF	4V		TEMSVAOG336M-8R	K78060036		1-	B	d3
C 3017	CHIP CAP.	0.1uF	16V	B	GRM39B104K16PT	K22124805		1-	B	d3
C 3018	CHIP CAP.	470pF	50V	B	GRM39B471M50PT	K22174805		1-	B	b1
C 3019	CHIP CAP.	470pF	50V	B	GRM39B471M50PT	K22174805		1-	B	a1
C 3020	CHIP CAP.	10pF	50V	CH	GRM39CH100D50PT	K22174211		1-	B	d3
C 3021	CHIP TA.CAP.	1uF	16V		TMCSA1C105MTR	K78120023		1-	B	c3
C 3022	CHIP CAP.	0.1uF	16V	B	GRM39B104K16PT	K22124805		1-	A	F2
C 3023	CHIP CAP.	4pF	50V	CH	GRM39CH040C50PT	K22174205		1-	B	b2
C 3024	CHIP TA.CAP.	4.7uF	16V		TEMSVB21C475M-8R	K78120016		1-	A	F2
C 3024	CHIP TA.CAP.	10uF	10V		TEMSVA1A106M-8R	K78100028		3-	A	F2
C 3025	CHIP CAP.	18pF	50V	CH	GRM39CH180J50PT	K22174217		1-	B	b2
C 3026	CHIP CAP.	0.1uF	16V	B	GRM39B104K16PT	K22124805		1-	A	F2
C 3027	CHIP TA.CAP.	4.7uF	16V		TEMSVB21C475M-8R	K78120016		1-	B	e2
C 3027	CHIP TA.CAP.	4.7uF	16V		TEMSVA1C475M-8R	K78120031		3-	B	e2
C 3028	CHIP CAP.	4pF	50V	CH	GRM39CH040C50PT	K22174205		1-	B	b3
C 3029	CHIP CAP.	0.01uF	25V	B	GRM39B103K25PT	K22144803		1-	B	e3
C 3030	TANTALUM CAP.	10uF	10V		DN1A100M1S	K70107106		1-	B	d2
C 3030	CHIP TA.CAP.	10uF	10V		TEMSVA1A106M-8R	K78100028		3-	B	d2
C 3031	CHIP CAP.	0.1uF	16V	B	GRM39B104K16PT	K22124805		1-	B	e3
C 3032	CHIP TA.CAP.	10uF	10V		TEMSVA1A106M-8R	K78100028		1-	B	e3
C 3034	CHIP CAP.	0.1uF	16V	B	GRM39B104K16PT	K22124805		1-	B	f1
C 3036	CHIP CAP.	0.1uF	16V	B	GRM39B104K16PT	K22124805		1-	A	F2
C 3037	CHIP CAP.	0.01uF	25V	B	GRM39B103K25PT	K22144803		1-	A	E1
C 3038	CHIP TA.CAP.	4.7uF	16V		TEMSVB21C475M-8R	K78120016		1-	A	D3
C 3038	CHIP TA.CAP.	10uF	10V		TEMSVA1A106M-8R	K78100028		3-	A	D3
C 3039	CHIP CAP.	0.001uF	50V	B	GRM39B102K50PT	K22174821		1-	B	e3
C 3040	CHIP CAP.	0.001uF	50V	B	GRM39B102K50PT	K22174821		1-	A	B3
C 3042	CHIP CAP.	0.1uF	16V	B	GRM39B104K16PT	K22124805		1-	A	F1
C 3043	CHIP TA.CAP.	10uF	10V		TEMSVA1A106M-8R	K78100028		1-	A	D3
C 3044	CHIP CAP.	0.1uF	16V	B	GRM39B104K16PT	K22124805		1-8	B	f2
C 3045	AL.ELECTRO.CAP.	100uF	16V		ECEV1CA101WP	K48120012		1-	B	e2
C 3047	CHIP CAP.	33pF	50V	CH	GRM39CH330J50PT	K22174223		1-	B	a2
C 3049	CHIP CAP.	33pF	50V	CH	GRM39CH330J50PT	K22174223		1-	B	a3
C 3050	CHIP CAP.	0.01uF	25V	B	GRM39B103K25PT	K22144803		1-	A	A2
C 3051	CHIP CAP.	0.1uF	16V	B	GRM39B104K16PT	K22124805		1-	B	f2
C 3053	AL.ELECTRO.CAP.	100uF	16V		ECEV1CA101WP	K48120012		1-	B	f2
C 3055	CHIP CAP.	0.01uF	25V	B	GRM39B103K25PT	K22144803		1-	B	f2
C 3056	CHIP CAP.	0.1uF	16V	B	GRM39B104K16PT	K22124805		1-	A	D3
C 3058	CHIP CAP.	0.01uF	25V	B	GRM39B103K25PT	K22144803		1-	B	f2
C 3059	CHIP TA.CAP.	4.7uF	16V		TEMSVB21C475M-8R	K78120016		1-	A	C3
C 3059	CHIP TA.CAP.	10uF	10V		TEMSVA1A106M-8R	K78100028		3-	A	C3
C 3060	CHIP CAP.	0.01uF	25V	B	GRM39B103K25PT	K22144803		1-	B	a1

# DISPLAY Unit

REF.	DESCRIPTION	VALUE	WV	TOL.	MFR'S DESIG	VXSTD P/N	VERS.	LOT.	SIDE.	LAY ADR.
C 3062	CHIP CAP.	0.1uF	16V	B	GRM39B104K16PT	K22124805		1-	B	d3
C 3063	CHIP CAP.	470pF	50V	B	GRM39B471M50PT	K22174805		1-	B	c1
C 3064	CHIP CAP.	470pF	50V	B	GRM39B471M50PT	K22174805		1-	B	b1
C 3065	CHIP CAP.	0.1uF	16V	B	GRM39B104K16PT	K22124805		1-	B	e3
C 3069	AL.ELECTRO.CAP.	100uF	16V		ECEV1CA101WP	K48120012		1-	B	e1
C 3070	AL.ELECTRO.CAP.	100uF	16V		ECEV1CA101WP	K48120012		1-	B	e1
C 3071	CERAMIC CAP.	0.022uF	50V	F	DD108F223Z50	K13179010		1-	A	G1
C 3071	CHIP CAP.	0.022uF	25V	B	GRM39B223K25PT	K22144807		3-	A	G1
C 3074	CHIP CAP.	0.1uF	16V	B	GRM39B104K16PT	K22124805		3-	B	d1
C 3075	TANTALUM CAP.	10uF	10V		DN1A100M1S	K70107106		1-	B	d2
C 3075	CHIP TA.CAP.	10uF	10V		TEMSVA1A106M-8R	K78100028		3-	B	d2
C 3076	CHIP CAP.	0.1uF	16V	B	GRM39B104K16PT	K22124805		3-	B	f3
C 3079	CHIP TA.CAP.	1uF	25V		TEMSVA1E105M-8R	K78140013		13-		
D 3005	DIODE				1SS226 TE85R	G2070003		1-	B	d3
D 3006	DIODE				DAP202U T106	G2070160		1-	A	F2
D 3008	DIODE				MC2848-T11-1	G2070694		1-	A	B2
D 3010	LED				TLOU1008(T4)	G2070796		1-	A	F1
D 3011	LED				TLOU262	G2090763		1-	A	A1
D 3012	LED				TLOU1008(T4)	G2070796		1-	A	F1
D 3013	LED				TLOU262	G2090763		1-	A	A2
D 3015	LED				GL3HS44	G2090675		1-	A	A2
D 3016	LED				GL3PR8	G2090433		1-	A	A1
D 3017	LED				GL3KG8	G2090432		1-	A	A1
D 3018	DIODE				MC2850-T11-1	G2070704		1-	A	A2
D 3019	DIODE				MC2850-T11-1	G2070704		1-	A	F1
D 3020	DIODE				BAS316	G2070716		1-	B	a1
D 3021	DIODE				BAS316	G2070716		1-	B	b1
D 3022	DIODE				BAS316	G2070716		1-	B	a1
D 3023	DIODE				BAS316	G2070716		1-	B	b1
DS3002	LCD				MS-6403	G6090140		1-	A	D1
J 3001	CONNECTOR				9210B-1-08Z696-T	P0091300		1-	A	F3
J 3005	CONNECTOR				9210B-1-08Z707-T	P0091304		1-	A	C2
J 3007	CONNECTOR				SB20-15WS	P0091093		1-	B	f2
J 3008	CONNECTOR				BM14B-SRSS-TBT	P0091302		1-	B	a1
J 3009	CONNECTOR				BM14B-SRSS-TBT	P0091302		1-	B	f2
JP3001	WIRE ASSY				GRN 20 2/2	T50502000		1-2		
JP3002	WIRE ASSY				GRN 50 2/2	T50505000		1-2		
L 3001	M.RFC	2.2uH			LK1608 2R2K-T	L1690634		1-	B	b3
Q 3001	IC				LC75823W	G1092941		1-	B	d1
Q 3003	TRANSISTOR				RT1N241M-T11-1	G3070249		1-	A	D3
Q 3004	TRANSISTOR				IMZ1 T108	G3070025		1-	B	b1
Q 3005	TRANSISTOR				RT1N241M-T11-1	G3070249		1-	B	a1
Q 3008	TRANSISTOR				RT1N241M-T11-1	G3070249		1-	B	d3
Q 3009	TRANSISTOR				RT1N241M-T11-1	G3070249		1-	B	c3
Q 3010	TRANSISTOR				IMX1 T110	G3070024		1-	B	b1
Q 3011	TRANSISTOR				IMZ1 T108	G3070025		1-	B	b1
Q 3012	IC				S-93C46AMFN-TB	G1093147		1-	A	F2
Q 3013	TRANSISTOR				IMD3 T108	G3070053		1-	B	b1
Q 3014	IC				HD64F3642AH R0508	G1093509		1-	B	b2
Q 3014	IC				HD64F3642AH R0527	G1093539		3-	B	b2
Q 3014	IC				HD64F3642AH(FLASH)*	G1093228		9-	B	b2
Q 3015	TRANSISTOR				IMH6A T108	G3070066		1-	B	d2
Q 3016	IC				S-80735SN-DZ-T1	G1091876		1-	B	e3
Q 3016	IC				S-80835CNMC-B8U-T2	G1093606		13-	B	e3
Q 3017	TRANSISTOR				2SA1602A-T11-1F	G3116028F		1-	B	f2
Q 3019	TRANSISTOR				2SC4154-T11-1E	G3341548E		1-	B	b3
Q 3020	TRANSISTOR				RT1N241M-T11-1	G3070249		1-	B	e2
Q 3021	IC				NJM78L05UA TE1	G1091325		1-	A	B3
Q 3022	TRANSISTOR				RT1N241M-T11-1	G3070249		1-	B	b2
Q 3024	TRANSISTOR				RT1N241M-T11-1	G3070249		1-8	B	e2

\* Requires Firmware, CE35 and FIF-8.



REF.	DESCRIPTION	VALUE	WV	TOL.	MFR'S DESIG	VXSTD P/N	VERS.	LOT.	SIDE	LAY ADR.
Q 3025	TRANSISTOR				RT1N241M-T11-1	G3070249		1-	B	b1
Q 3026	TRANSISTOR				RT1N241M-T11-1	G3070249		1-	B	e2
Q 3027	TRANSISTOR				RT1N241M-T11-1	G3070249		1-	B	f3
Q 3028	TRANSISTOR				2SB1132 T100 Q	G3211327Q		1-	B	f2
Q 3029	TRANSISTOR				2SB1132 T100 Q	G3211327Q		1-	B	a3
Q 3030	TRANSISTOR				UMW1 TR	G3070078		1-	B	a2
Q 3031	TRANSISTOR				2SB1132 T100 Q	G3211327Q		1-	A	B2
Q 3033	TRANSISTOR				IMH6A T108	G3070066		1-	B	f2
Q 3038	TRANSISTOR				IMX1 T110	G3070024		1-	B	d3
Q 3039	IC				NJM2902V-TE1	G1091679		1-	B	d3
Q 3040	TRANSISTOR				IMZ1 T108	G3070025		1-	B	b1
Q 3043	IC				TC4S66F TE85R	G1090893		1-	B	b1
R 3002	CHIP RES.	47k	1/16W	5%	RMC1/16 473JATP	J24185473		1-	B	c1
R 3004	CHIP RES.	2.2k	1/16W	5%	RMC1/16 222JATP	J24185222		1-	B	d3
R 3006	CHIP RES.	56k	1/16W	5%	RMC1/16 563JATP	J24185563		1-	A	A2
R 3007	CHIP RES.	15k	1/16W	5%	RMC1/16 153JATP	J24185153		1-	A	D3
R 3008	CHIP RES.	27k	1/16W	5%	RMC1/16 273JATP	J24185273		1-	B	d3
R 3017	CHIP RES.	100k	1/16W	5%	RMC1/16 104JATP	J24185104		1-	B	d3
R 3018	CHIP RES.	4.7k	1/16W	5%	RMC1/16 472JATP	J24185472		1-	B	b1
R 3019	CHIP RES.	4.7k	1/16W	5%	RMC1/16 472JATP	J24185472		1-	B	b1
R 3020	CHIP RES.	4.7k	1/16W	5%	RMC1/16 472JATP	J24185472		1-	B	b1
R 3021	CHIP RES.	4.7k	1/16W	5%	RMC1/16 472JATP	J24185472		1-	B	a1
R 3022	CHIP RES.	2.2k	1/16W	5%	RMC1/16 222JATP	J24185222		1-	B	a1
R 3023	CHIP RES.	4.7k	1/16W	5%	RMC1/16 472JATP	J24185472		1-	B	a1
R 3024	CHIP RES.	330	1/16W	5%	RMC1/16 331JATP	J24185331		1-	B	e1
R 3025	CHIP RES.	4.7k	1/16W	5%	RMC1/16 472JATP	J24185472		1-	B	a1
R 3026	CHIP RES.	10k	1/16W	5%	RMC1/16 103JATP	J24185103		1-	B	c2
R 3027	CHIP RES.	10k	1/16W	5%	RMC1/16 103JATP	J24185103		1-	B	c3
R 3030	CHIP RES.	680	1/16W	5%	RMC1/16 681JATP	J24185681		1-	A	A3
R 3031	CHIP RES.	22k	1/16W	5%	RMC1/16 223JATP	J24185223		1-	B	d3
R 3033	CHIP RES.	1.5M	1/16W	5%	RMC1/16 155JATP	J24185155		1-	B	d3
R 3034	CHIP RES.	220	1/16W	5%	RMC1/16 221JATP	J24185221		1-	B	d3
R 3035	CHIP RES.	4.7k	1/16W	5%	RMC1/16 472JATP	J24185472		1-	B	a1
R 3036	CHIP RES.	4.7k	1/16W	5%	RMC1/16 472JATP	J24185472		1-	B	a1
R 3037	CHIP RES.	4.7k	1/16W	5%	RMC1/16 472JATP	J24185472		1-	B	a1
R 3038	CHIP RES.	2.2k	1/16W	5%	RMC1/16 222JATP	J24185222		1-	B	b2
R 3039	CHIP RES.	4.7k	1/16W	5%	RMC1/16 472JATP	J24185472		1-	B	b1
R 3040	CHIP RES.	4.7k	1/16W	5%	RMC1/16 472JATP	J24185472		1-	B	b1
R 3041	CHIP RES.	4.7k	1/16W	5%	RMC1/16 472JATP	J24185472		1-	B	b1
R 3042	CHIP RES.	4.7k	1/16W	5%	RMC1/16 472JATP	J24185472		1-	B	a1
R 3043	CHIP RES.	15k	1/16W	5%	RMC1/16 153JATP	J24185153		1-	B	d3
R 3044	CHIP RES.	15k	1/16W	5%	RMC1/16 153JATP	J24185153		1-	B	d3
R 3045	CHIP RES.	330k	1/16W	5%	RMC1/16 334JATP	J24185334		1-	B	d3
R 3046	CHIP RES.	220k	1/16W	5%	RMC1/16 224JATP	J24185224		1-	B	c3
R 3047	CHIP RES.	2.2k	1/16W	5%	RMC1/16 222JATP	J24185222		1-	B	d3
R 3048	CHIP RES.	10k	1/16W	5%	RMC1/16 103JATP	J24185103		1-	B	c2
R 3049	CHIP RES.	2.2M	1/16W	5%	RMC1/16 225JATP	J24185225		1-	B	c3
R 3050	CHIP RES.	10k	1/16W	5%	RMC1/16 103JATP	J24185103		1-	B	c3
R 3051	CHIP RES.	1k	1/16W	5%	RMC1/16 102JATP	J24185102		1-	B	d3
R 3052	CHIP RES.	220	1/16W	5%	RMC1/16 221JATP	J24185221		1-	B	d3
R 3053	CHIP RES.	1.2M	1/16W	5%	RMC1/16 125JATP	J24185125		1-	B	d3
R 3054	CHIP RES.	4.7k	1/16W	5%	RMC1/16 472JATP	J24185472		1-	B	b1
R 3055	CHIP RES.	4.7k	1/16W	5%	RMC1/16 472JATP	J24185472		1-	B	b1
R 3056	CHIP RES.	4.7k	1/16W	5%	RMC1/16 472JATP	J24185472		1-	B	a1
R 3057	CHIP RES.	4.7k	1/16W	5%	RMC1/16 472JATP	J24185472		1-	B	a1
R 3058	CHIP RES.	10k	1/16W	5%	RMC1/16 103JATP	J24185103		1-	B	b1
R 3059	CHIP RES.	10k	1/16W	5%	RMC1/16 103JATP	J24185103		1-	B	b1
R 3060	CHIP RES.	330k	1/16W	5%	RMC1/16 334JATP	J24185334		1-	B	c3
R 3061	CHIP RES.	10k	1/16W	5%	RMC1/16 103JATP	J24185103		1-	B	d3
R 3062	CHIP RES.	1.2M	1/16W	5%	RMC1/16 125JATP	J24185125		1-	B	d3

# DISPLAY Unit

REF.	DESCRIPTION	VALUE	WV	TOL.	MFR'S DESIG	VXSTD P/N	VERS.	LOT.	SIDE.	LAY ADR.
R 3063	CHIP RES.	10k	1/16W	5%	RMC1/16 103JATP	J24185103		1-	B	c3
R 3064	CHIP RES.	1.2k	1/16W	5%	RMC1/16 122JATP	J24185122		1-	B	a1
R 3065	CHIP RES.	2.7k	1/16W	5%	RMC1/16 272JATP	J24185272		1-	B	a1
R 3066	CHIP RES.	5.6k	1/16W	5%	RMC1/16 562JATP	J24185562		1-	B	a1
R 3067	CHIP RES.	12k	1/16W	5%	RMC1/16 123JATP	J24185123		1-	B	b1
R 3068	CHIP RES.	10k	1/16W	5%	RMC1/16 103JATP	J24185103		1-	B	a2
R 3069	CHIP RES.	10k	1/16W	5%	RMC1/16 103JATP	J24185103		1-	B	a2
R 3070	CHIP RES.	1M	1/16W	5%	RMC1/16 105JATP	J24185105		1-	A	F3
R 3071	CHIP RES.	10k	1/16W	5%	RMC1/16 103JATP	J24185103		1-	B	d2
R 3072	CHIP RES.	10k	1/16W	5%	RMC1/16 103JATP	J24185103		1-	B	d2
R 3073	CHIP RES.	2.2k	1/16W	5%	RMC1/16 222JATP	J24185222		1-	B	d2
R 3074	CHIP RES.	47k	1/16W	5%	RMC1/16 473JATP	J24185473		1-	A	F2
R 3075	CHIP RES.	10k	1/16W	5%	RMC1/16 103JATP	J24185103		1-	B	e2
R 3076	CHIP RES.	47k	1/16W	5%	RMC1/16 473JATP	J24185473		1-	B	d2
R 3077	CHIP RES.	47k	1/16W	5%	RMC1/16 473JATP	J24185473		1-	B	e2
R 3078	CHIP RES.	47k	1/16W	5%	RMC1/16 473JATP	J24185473		1-	B	f1
R 3079	CHIP RES.	15k	1/16W	5%	RMC1/16 153JATP	J24185153		1-	A	A2
R 3080	CHIP RES.	220k	1/16W	5%	RMC1/16 224JATP	J24185224		1-	B	f2
R 3081	CHIP RES.	12k	1/16W	5%	RMC1/16 123JATP	J24185123		1-	A	A2
R 3082	CHIP RES.	330k	1/16W	5%	RMC1/16 334JATP	J24185334		1-	A	F2
R 3083	CHIP RES.	68k	1/16W	5%	RMC1/16 683JATP	J24185683		1-	A	F1
R 3084	CHIP RES.	33k	1/16W	5%	RMC1/16 333JATP	J24185333		1-	A	F1
R 3085	CHIP RES.	27k	1/16W	5%	RMC1/16 273JATP	J24185273		1-	B	b1
R 3086	CHIP RES.	56k	1/16W	5%	RMC1/16 563JATP	J24185563		1-	B	b1
R 3087	CHIP RES.	120k	1/16W	5%	RMC1/16 124JATP	J24185124		1-	B	b1
R 3088	CHIP RES.	220k	1/16W	5%	RMC1/16 224JATP	J24185224		1-	B	b1
R 3089	CHIP RES.	15k	1/16W	5%	RMC1/16 153JATP	J24185153		1-	B	b2
R 3090	CHIP RES.	47k	1/16W	5%	RMC1/16 473JATP	J24185473		1-	A	A3
R 3091	CHIP RES.	47k	1/16W	5%	RMC1/16 473JATP	J24185473		1-8	A	B2
R 3092	CHIP RES.	10k	1/16W	5%	RMC1/16 103JATP	J24185103		1-	A	F2
R 3093	CHIP RES.	10k	1/16W	5%	RMC1/16 103JATP	J24185103		1-	A	E1
R 3095	CHIP RES.	2.2k	1/16W	5%	RMC1/16 222JATP	J24185222		1-	B	e2
R 3096	CHIP RES.	12k	1/16W	5%	RMC1/16 123JATP	J24185123		1-	A	C3
R 3097	CHIP RES.	10k	1/16W	5%	RMC1/16 103JATP	J24185103		1-	A	D3
R 3099	CHIP RES.	1k	1/16W	5%	RMC1/16 102JATP	J24185102		1-	B	f2
R 3103	CHIP RES.	10k	1/16W	5%	RMC1/16 103JATP	J24185103		1-	B	b2
R 3104	CHIP RES.	15k	1/16W	5%	RMC1/16 153JATP	J24185153		1-	A	F1
R 3105	CHIP RES.	12k	1/16W	5%	RMC1/16 123JATP	J24185123		1-	A	F1
R 3106	CHIP RES.	6.8k	1/16W	5%	RMC1/16 682JATP	J24185682		1-	A	F1
R 3107	CHIP RES.	8.2k	1/16W	5%	RMC1/16 822JATP	J24185822		1-	A	F2
R 3108	CHIP RES.	10k	1/16W	5%	RMC1/16 103JATP	J24185103		1-	B	f2
R 3109	CHIP RES.	15	1/2W	5%	RMC1/2 150JCTP	J24275150		1-	A	B2
R 3110	CHIP RES.	560	1/16W	5%	RMC1/16 561JATP	J24185561		1-	B	d2
R 3111	CHIP RES.	47k	1/16W	5%	RMC1/16 473JATP	J24185473		1-	B	f2
R 3112	CHIP RES.	0	1/16W	5%	RMC1/16 000JATP	J24185000		1-	A	F2
R 3113	CHIP RES.	33k	1/16W	5%	RMC1/16 333JATP	J24185333		1-	B	a2
R 3114	CHIP RES.	4.7k	1/16W	5%	RMC1/16 472JATP	J24185472		1-	B	a2
R 3115	CHIP RES.	47k	1/16W	5%	RMC1/16 473JATP	J24185473		1-	B	a2
R 3116	CHIP RES.	2.2k	1/16W	5%	RMC1/16 222JATP	J24185222		1-	B	a2
R 3117	CHIP RES.	1k	1/16W	5%	RMC1/16 102JATP	J24185102		1-	B	a2
R 3118	CHIP RES.	6.8k	1/16W	5%	RMC1/16 682JATP	J24185682		1-	B	a2
R 3119	CHIP RES.	180	1/4W	5%	RMC1/4 181JATP	J24245181		1-	B	f1
R 3120	CHIP RES.	1k	1/16W	5%	RMC1/16 102JATP	J24185102		1-	B	a2
R 3121	CHIP RES.	6.8k	1/16W	5%	RMC1/16 682JATP	J24185682		1-	B	a2
R 3122	CHIP RES.	2.2k	1/16W	5%	RMC1/16 222JATP	J24185222		1-	B	a2
R 3123	CHIP RES.	4.7k	1/16W	5%	RMC1/16 472JATP	J24185472		1-	B	a3
R 3124	CHIP RES.	470	1/16W	5%	RMC1/16 471JATP	J24185471		1-	B	f2
R 3125	CHIP RES.	330	1/16W	5%	RMC1/16 331JATP	J24185331		1-	B	f1
R 3126	CHIP RES.	100	1/16W	5%	RMC1/16 101JATP	J24185101		1-	B	f1
R 3127	CHIP RES.	10k	1/16W	5%	RMC1/16 103JATP	J24185103		1-	B	e1

REF.	DESCRIPTION	VALUE	WV	TOL.	MFR'S DESIG	VXSTD P/N	VERS.	LOT.	SIDE	LAY ADR.
R 3128	CHIP RES.	1k	1/16W	5%	RMC1/16 102JATP	J24185102		1-	A	A2
R 3129	CHIP RES.	47k	1/16W	5%	RMC1/16 473JATP	J24185473		1-	B	e2
R 3135	CHIP RES.	8.2	1W	5%	RMC1 8R2JTE	J24305829		1-	B	e1
R 3136	CHIP RES.	330	1/16W	5%	RMC1/16 331JATP	J24185331		1-	A	A2
R 3137	CHIP RES.	330	1/16W	5%	RMC1/16 331JATP	J24185331		1-	A	F3
R 3142	CHIP RES.	56k	1/16W	5%	RMC1/16 563JATP	J24185563		1-	B	a2
R 3143	CHIP RES.	680	1/16W	5%	RMC1/16 681JATP	J24185681		1-	A	C3
R 3144	CHIP RES.	22k	1/16W	5%	RMC1/16 223JATP	J24185223		1-	A	C3
R 3145	CHIP RES.	47k	1/16W	5%	RMC1/16 473JATP	J24185473		1-	B	e2
R 3146	CHIP RES.	220	1/4W	5%	RMC1/4 221JATP	J24245221		1-	A	B3
R 3147	CHIP RES.	0	1/16W	5%	RMC1/16 000JATP	J24185000		1-	A	A1
R 3150	CHIP RES.	470	1/4W	5%	RMC1/4 471JATP	J24245471		1-	B	f1
R 3152	CHIP RES.	4.7k	1/16W	5%	RMC1/16 472JATP	J24185472		1-	B	b1
R 3153	CHIP RES.	4.7k	1/16W	5%	RMC1/16 472JATP	J24185472		1-	B	b1
R 3154	CHIP RES.	4.7k	1/16W	5%	RMC1/16 472JATP	J24185472		1-	B	b1
R 3155	CHIP RES.	4.7k	1/16W	5%	RMC1/16 472JATP	J24185472		1-	B	c1
R 3156	CHIP RES.	4.7k	1/16W	5%	RMC1/16 472JATP	J24185472		1-	B	c1
R 3157	CHIP RES.	2.2k	1/16W	5%	RMC1/16 222JATP	J24185222		1-	B	b2
R 3158	CHIP RES.	180k	1/16W	5%	RMC1/16 184JATP	J24185184		1-	B	e3
R 3159	CHIP RES.	10k	1/16W	5%	RMC1/16 103JATP	J24185103		1-	B	d2
R 3160	CHIP RES.	4.7	1W	5%	RMC1 4R7JTE	J24305479		1-	B	g2
R 3161	CHIP RES.	4.7	1W	5%	RMC1 4R7JTE	J24305479		1-	B	g2
R 3162	CHIP RES.	2.7k	1/16W	5%	RMC1/16 272JATP	J24185272		1-	B	d3
R 3164	CHIP RES.	0	1/16W	5%	RMC1/16 000JATP	J24185000		1-	B	d2
R 3166	CHIP RES.	1	1/10W	5%	RMC1/10T 1R0J	J24205010		3-	A	G1
R 3167	CARBON FILM RES.	10k	1/6W	5%	RD16PJ103 10K	J01225103		1-		
R 3168	CHIP RES.	8.2k	1/16W	5%	RMC1/16 822JATP	J24185822		9-		
S 3007	TACT SWITCH				SKQDAB	N5090058		1-	A	A1
S 3008	TACT SWITCH				SKQDAB	N5090058		1-	A	F1
S 3009	TACT SWITCH				SKQDAB	N5090058		1-	A	F1
X 3001	XTAL 92SMX(A)	16MHz			16.000MHZ	H0103252		1-	B	a3
	LIGHT GUIDE					RA0252300		1-		
	REFLECTOR SHEET					RA0252700		1-		
	DIFFUSER SHEET					RA0252800		1-		
	RUBBER CONNECTOR					RA0252900		1-		
	LCD HOLDER					RA0253000		1-		
	LED SPACER				LH-5-6	S6000239		1-		
	LIGHT SHEET					RA0276500		5-		

# ***DISPLAY Unit***

***Note:***

Circuit Diagram

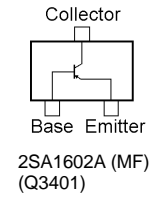
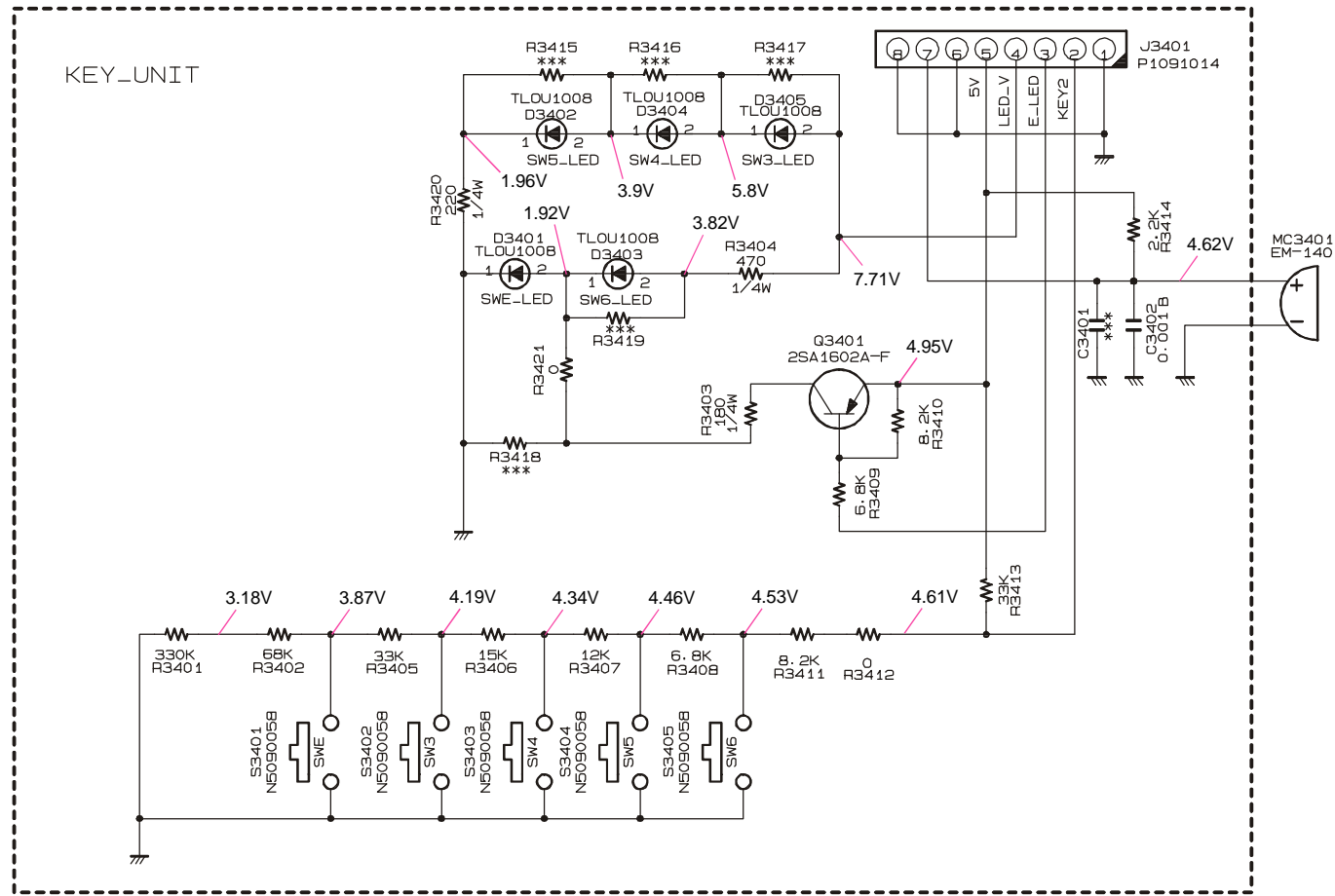

Parts Layout

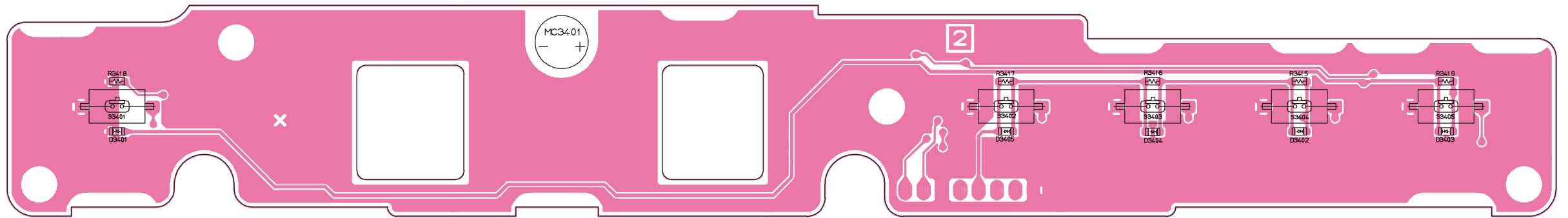

Side A

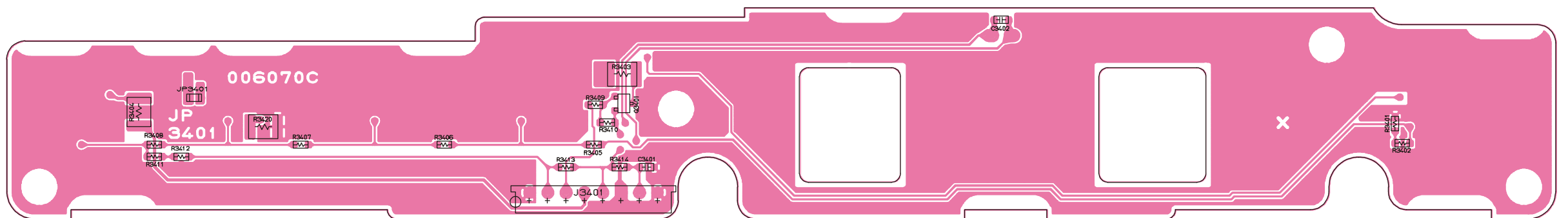

Side B

**KEY Unit (Lot. 1~)**

**Note:**

**Circuit Diagram**

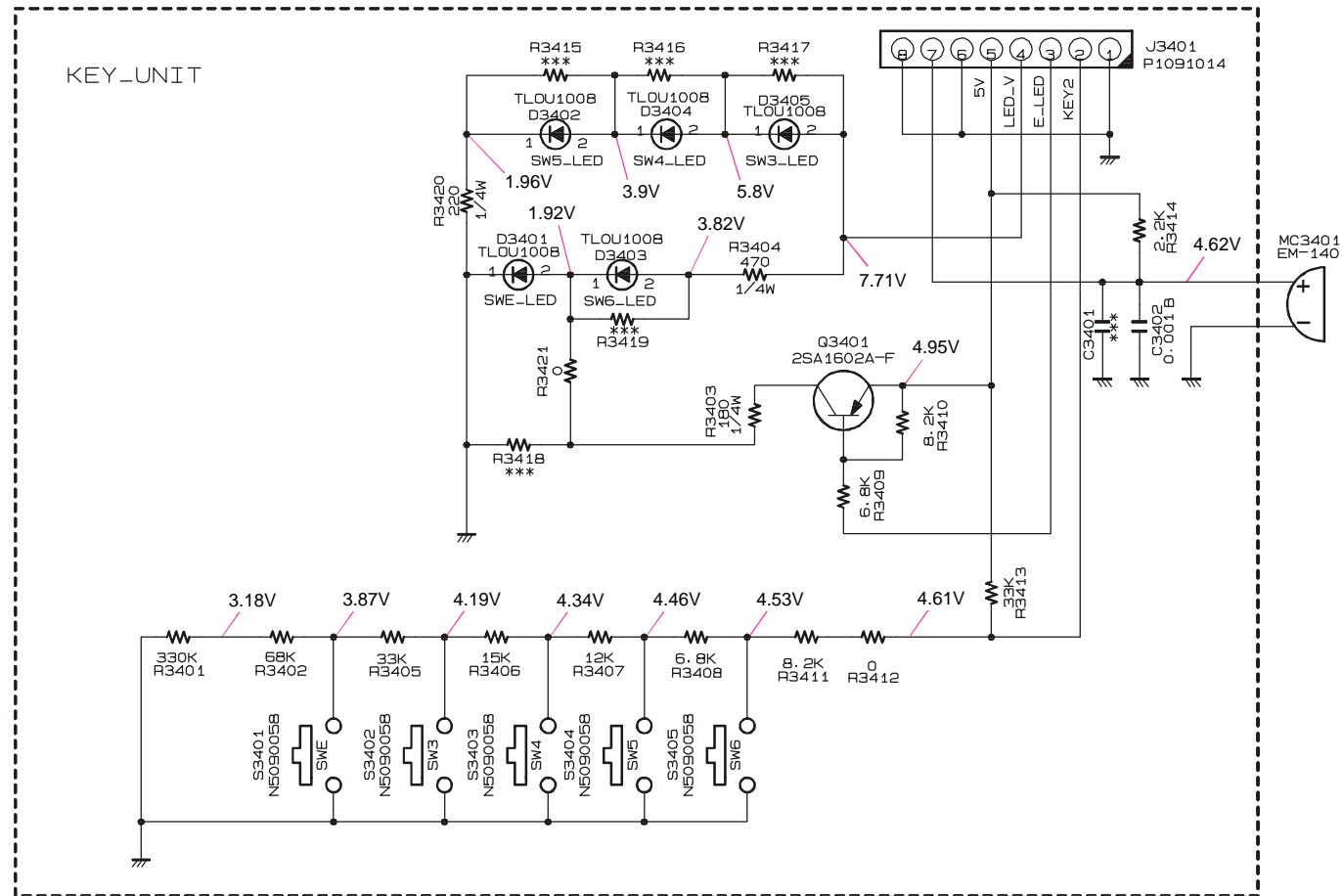

**Parts Layout**

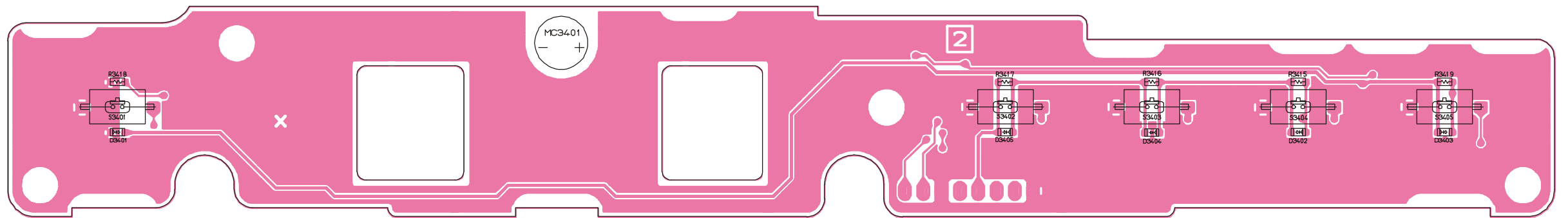

Side A

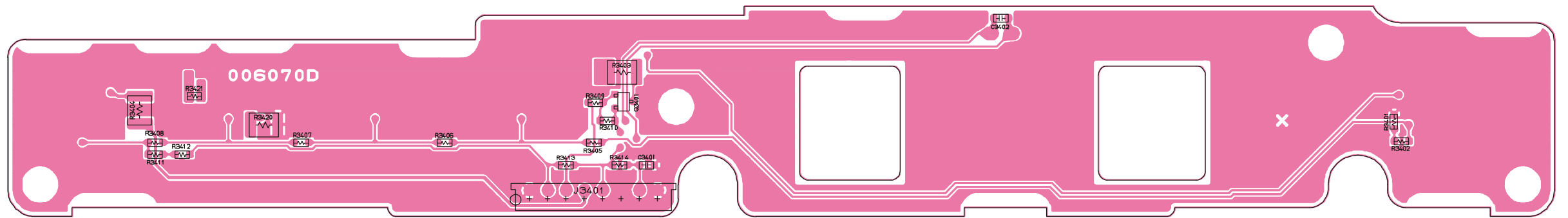

Side B

## ***KEY Unit (Lot. 3~)***

***Note:***



## Parts List

REF.	DESCRIPTION	VALUE	WV	TOL.	MFR'S DESIG	VXSTD P/N	VERS.	LOT.	SIDE	LAY ADR.
*** KEY UNIT ***										
PCB with Components						CB1452001				
Printed Circuit Board						FR006070C		1-		
Printed Circuit Board						FR006070D		3-		
C 3402	CHIP CAP.	0.001uF	50V	B	GRM39B102K50PT	K22174821		1-	B	
D 3401	LED				TLOU1008(T4)	G2070796		1-	A	
D 3402	LED				TLOU1008(T4)	G2070796		1-	A	
D 3403	LED				TLOU1008(T4)	G2070796		1-	A	
D 3404	LED				TLOU1008(T4)	G2070796		1-	A	
D 3405	LED				TLOU1008(T4)	G2070796		1-	A	
J 3401	CONNECTOR				9110S-08	P1091014		1-	B	
MC3401	MIC. ELEMENT				EM-140	M3290032		1-	A	
Q 3401	TRANSISTOR				2SA1602A-T11-1F	G3116028F		1-	B	
R 3401	CHIP RES.	330k	1/16W	5%	RMC1/16 334JATP	J24185334		1-	B	
R 3402	CHIP RES.	68k	1/16W	5%	RMC1/16 683JATP	J24185683		1-	B	
R 3403	CHIP RES.	180	1/4W	5%	RMC1/4 181JATP	J24245181		1-	B	
R 3404	CHIP RES.	470	1/4W	5%	RMC1/4 471JATP	J24245471		1-	B	
R 3405	CHIP RES.	33k	1/16W	5%	RMC1/16 333JATP	J24185333		1-	B	
R 3406	CHIP RES.	15k	1/16W	5%	RMC1/16 153JATP	J24185153		1-	B	
R 3407	CHIP RES.	12k	1/16W	5%	RMC1/16 123JATP	J24185123		1-	B	
R 3408	CHIP RES.	6.8k	1/16W	5%	RMC1/16 682JATP	J24185682		1-	B	
R 3409	CHIP RES.	6.8k	1/16W	5%	RMC1/16 682JATP	J24185682		1-	B	
R 3410	CHIP RES.	8.2k	1/16W	5%	RMC1/16 822JATP	J24185822		1-	B	
R 3411	CHIP RES.	8.2k	1/16W	5%	RMC1/16 822JATP	J24185822		1-	B	
R 3412	CHIP RES.	0	1/16W	5%	RMC1/16 000JATP	J24185000		1-	B	
R 3413	CHIP RES.	33k	1/16W	5%	RMC1/16 333JATP	J24185333		1-	B	
R 3414	CHIP RES.	2.2k	1/16W	5%	RMC1/16 222JATP	J24185222		1-	B	
R 3420	CHIP RES.	220	1/4W	5%	RMC1/4 221JATP	J24245221		1-	B	
R 3421	CHIP RES.	0	1/16W	5%	RMC1/16 000JATP	J24185000		3-	B	
S 3401	TACT SWITCH				SKQDAB	N5090058		1-	A	
S 3402	TACT SWITCH				SKQDAB	N5090058		1-	A	
S 3403	TACT SWITCH				SKQDAB	N5090058		1-	A	
S 3404	TACT SWITCH				SKQDAB	N5090058		1-	A	
S 3405	TACT SWITCH				SKQDAB	N5090058		1-	A	

## ***KEY Unit***

***Note:***

## Circuit Diagram

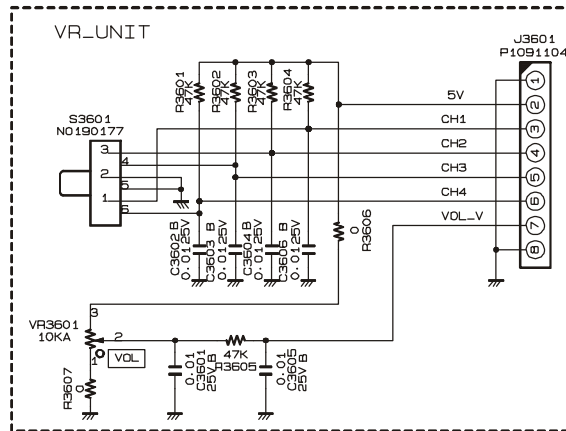

## Parts Layout

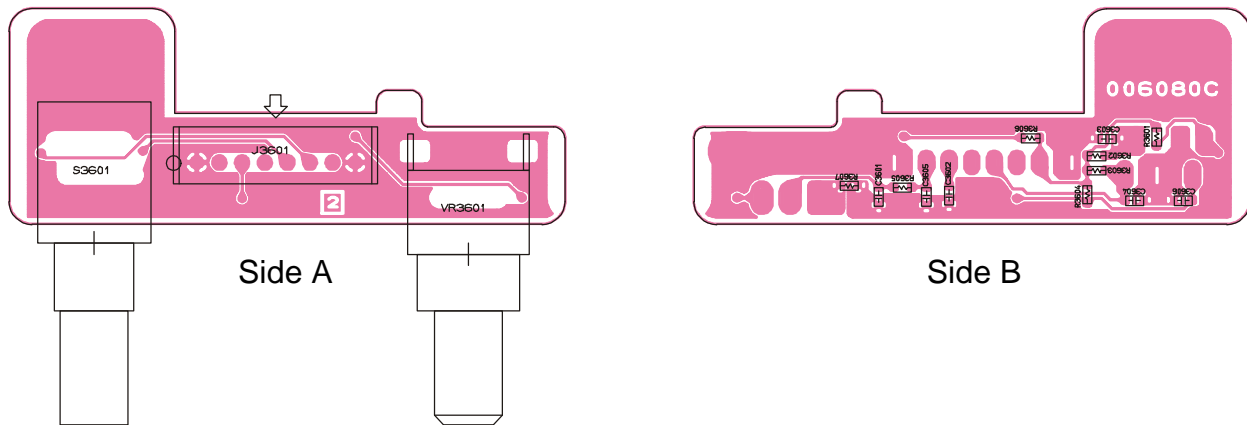

## Parts List

REF.	DESCRIPTION	VALUE	WV	TOL.	MFR'S DESIG	VXSTD P/N	VERS.	LOT.	SIDE	LAY ADR
*** VR UNIT ***										
PCB with Components						CB1350001				
Printed Circuit Board						FR006080C			1-	
C 3601	CHIP CAP.	0.01uF	25V	B	GRM39B103K25PT	K22144803		1-	B	
C 3602	CHIP CAP.	0.01uF	25V	B	GRM39B103K25PT	K22144803		1-	B	
C 3603	CHIP CAP.	0.01uF	25V	B	GRM39B103K25PT	K22144803		1-	B	
C 3604	CHIP CAP.	0.01uF	25V	B	GRM39B103K25PT	K22144803		1-	B	
C 3605	CHIP CAP.	0.01uF	25V	B	GRM39B103K25PT	K22144803		1-	B	
C 3606	CHIP CAP.	0.01uF	25V	B	GRM39B103K25PT	K22144803		1-	B	
J 3601	CONNECTOR				9110S-08L	P1091104		1-	A	
R 3601	CHIP RES.	47k	1/16W	5%	RMC1/16 473JATP	J24185473		1-	B	
R 3602	CHIP RES.	47k	1/16W	5%	RMC1/16 473JATP	J24185473		1-	B	
R 3603	CHIP RES.	47k	1/16W	5%	RMC1/16 473JATP	J24185473		1-	B	
R 3604	CHIP RES.	47k	1/16W	5%	RMC1/16 473JATP	J24185473		1-	B	
R 3605	CHIP RES.	47k	1/16W	5%	RMC1/16 473JATP	J24185473		1-	B	
R 3606	CHIP RES.	0	1/16W	5%	RMC1/16 000JATP	J24185000		1-	B	
R 3607	CHIP RES.	0	1/16W	5%	RMC1/16 000JATP	J24185000		1-	B	
S 3601	ROTARY SWITCH				SRZW0L	N0190177		1-	A	
VR3601	POT.				RK09L1120 L=15 10KC	J60800253		1-	A	
VR3601	POT.				RK09L1120 L=15 10KC	J60800258		5-	A	

# MIC CONN Unit

## Circuit Diagram

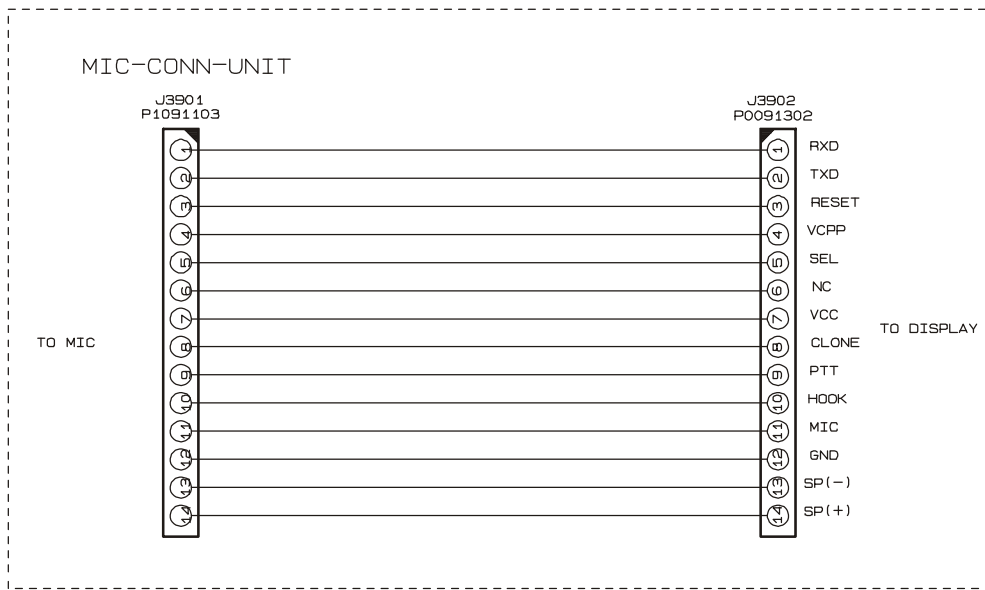

## Parts Layout

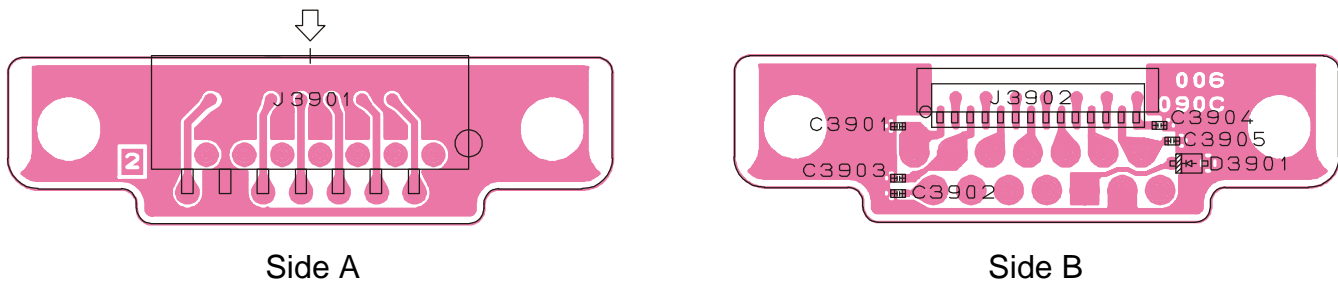

## Parts List

REF.	DESCRIPTION	VALUE	WV	TOL.	MFR'S DESIG	VXSTD P/N	VERS.	LOT.	SIDE	LAY ADR.
*** MIC CONN UNIT ***										
PCB with Components						CB1384001				
Printed Circuit Board						FR006090C		1-		
J 3901	CONNECTOR				14FE-ST-VK-N	P1091103		1-	A	
J 3902	CONNECTOR				BM14B-SRSS-TBT	P0091302		1-	B	

# F2D-8 2-Tone Decode Unit

## Circuit Diagram

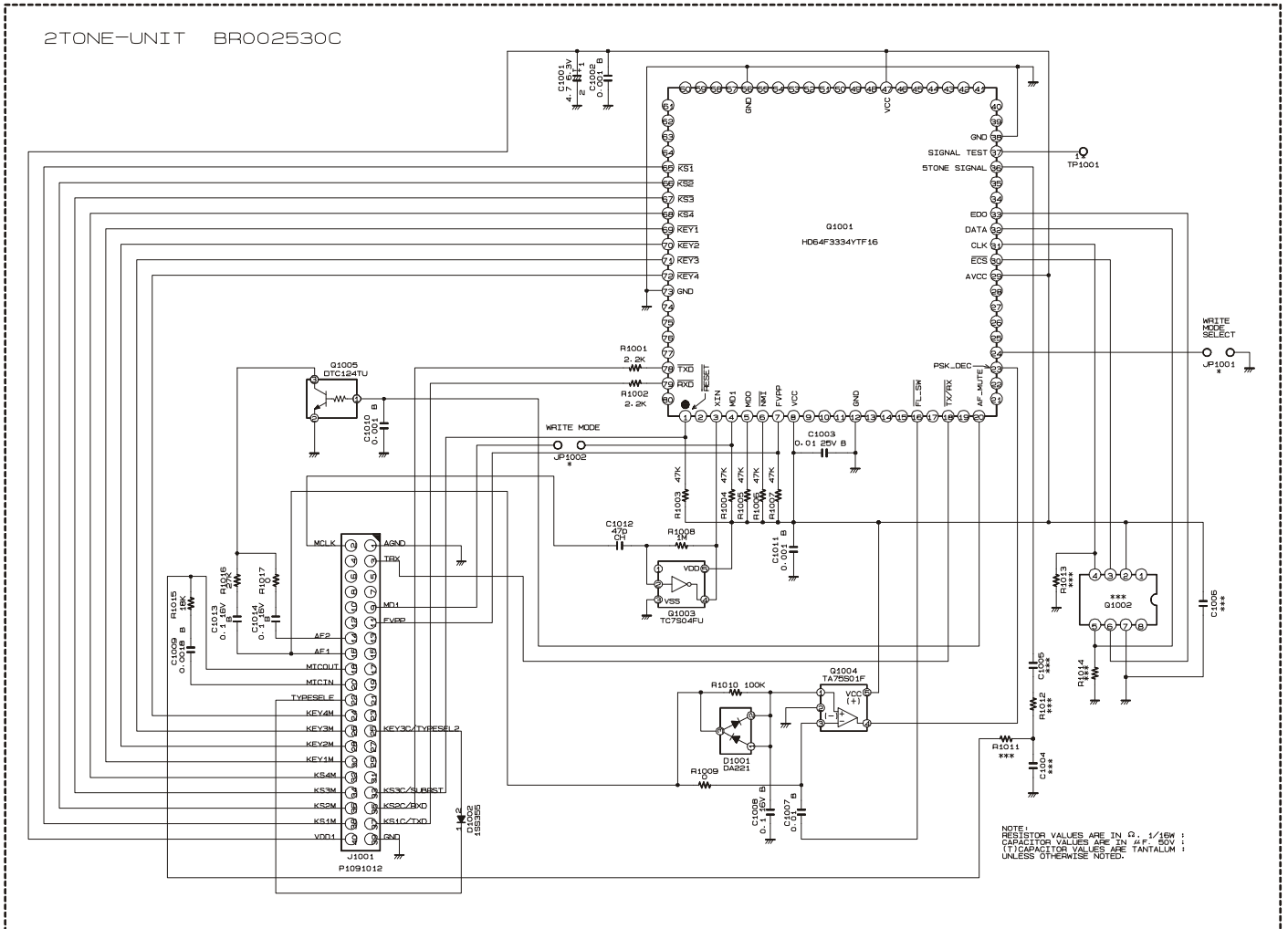

## Parts Layout

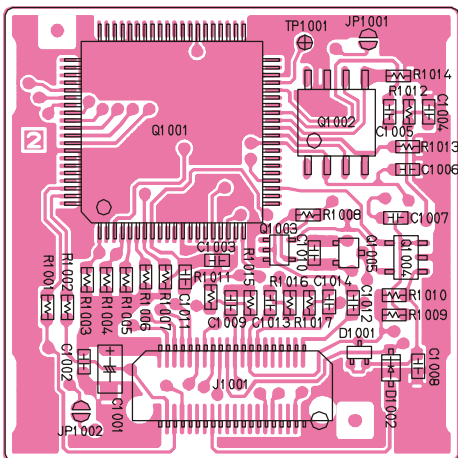

Side A

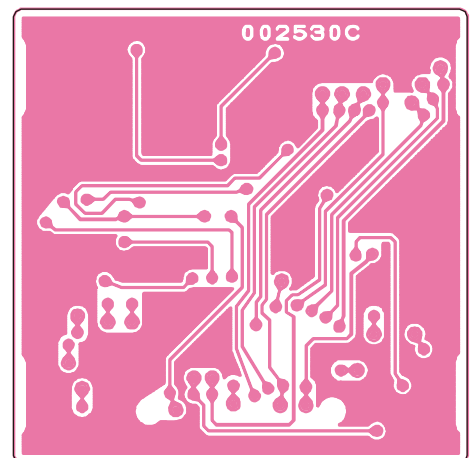

Side B

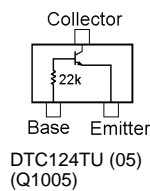
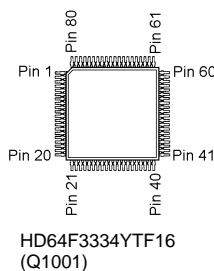
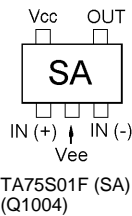
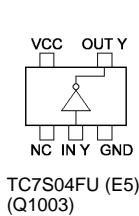

# F2D-8 2-Tone Decode Unit

## Parts List

REF.	DESCRIPTION	VALUE	V/W	TOL.	MFR'S DESIG	VXSTD P/N	VERS.	LOT.	SIDE	LAY ADR
*** F2D-8 ***										
Printed Circuit Board						FR002530C		1-		
C 1001	CHIP TA.CAP.	4.7uF	6.3V		TEMSVA0J475M-8R	K78080017		1-	A	
C 1002	CHIP CAP.	0.001uF	50V	B	GRM39B102K50PT	K22174821		1-	A	
C 1003	CHIP CAP.	0.01uF	25V	B	GRM39B103K25PT	K22144803		1-	A	
C 1007	CHIP CAP.	0.1uF	16V	B	GRM39B104K16PT	K22124805		1-	A	
C 1007	CHIP CAP.	0.0015uF	50V	B	GRM39B152M50PT	K22174811		6-	A	
C 1007	CHIP CAP.	0.01uF	50V	B	GRM39B103M50PT	K22174823		18-	A	
C 1008	CHIP CAP.	0.1uF	16V	B	GRM39B104K16PT	K22124805		1-	A	
C 1009	CHIP CAP.	0.0018uF	50V	B	GRM39B182M50PT	K22174812		1-	A	
C 1010	CHIP CAP.	0.001uF	50V	B	GRM39B102K50PT	K22174821		1-	A	
C 1011	CHIP CAP.	0.001uF	50V	B	GRM39B102K50PT	K22174821		1-	A	
C 1012	CHIP CAP.	47pF	50V	CH	GRM39CH470J50PT	K22174227		1-	A	
C 1013	CHIP CAP.	0.1uF	16V	B	GRM39B104K16PT	K22124805		1-	A	
C 1014	CHIP CAP.	0.1uF	16V	B	GRM39B104K16PT	K22124805		1-	A	
D 1001	DIODE				DA221 TL	G2070178		1-	A	
D 1002	DIODE				1SS355 TE-17	G2070470		1-	A	
J 1001	CONNECTOR				AXK5S40035P	P1091012		1-	A	
Q 1001	IC				HD64F3334YTF16 R0226	G1092873		1-	A	
Q 1003	IC				TC7S04FU TE85R	G1091530		1-	A	
Q 1004	IC				TA75S01F TE85R	G1091593		1-	A	
Q 1005	TRANSISTOR				DTC124TU T106	G3070065		1-	A	
R 1001	CHIP RES.	2.2k	1/16W	5%	RMC1/16 222JATP	J24185222		1-	A	
R 1002	CHIP RES.	2.2k	1/16W	5%	RMC1/16 222JATP	J24185222		1-	A	
R 1003	CHIP RES.	47k	1/16W	5%	RMC1/16 473JATP	J24185473		1-	A	
R 1004	CHIP RES.	47k	1/16W	5%	RMC1/16 473JATP	J24185473		1-	A	
R 1005	CHIP RES.	47k	1/16W	5%	RMC1/16 473JATP	J24185473		1-	A	
R 1006	CHIP RES.	47k	1/16W	5%	RMC1/16 473JATP	J24185473		1-	A	
R 1007	CHIP RES.	47k	1/16W	5%	RMC1/16 473JATP	J24185473		1-	A	
R 1008	CHIP RES.	1M	1/16W	5%	RMC1/16 105JATP	J24185105		1-	A	
R 1009	CHIP RES.	4.7k	1/16W	5%	RMC1/16 472JATP	J24185472		1-	A	
R 1009	CHIP RES.	0	1/16W	5%	RMC1/16 000JATP	J24185000		6-	A	
R 1010	CHIP RES.	100k	1/16W	5%	RMC1/16 104JATP	J24185104		1-	A	
R 1015	CHIP RES.	18k	1/16W	5%	RMC1/16 183JATP	J24185183		1-	A	
R 1016	CHIP RES.	0	1/16W	5%	RMC1/16 000JATP	J24185000		1-	A	
R 1016	CHIP RES.	27k	1/16W	5%	RMC1/16 273JATP	J24185273		6-	A	
R 1017	CHIP RES.	0	1/16W	5%	RMC1/16 000JATP	J24185000		1-	A	
	BLIND SHEET					RA0109300		1-		

# F5D-14 5-Tone Unit

## Circuit Diagram

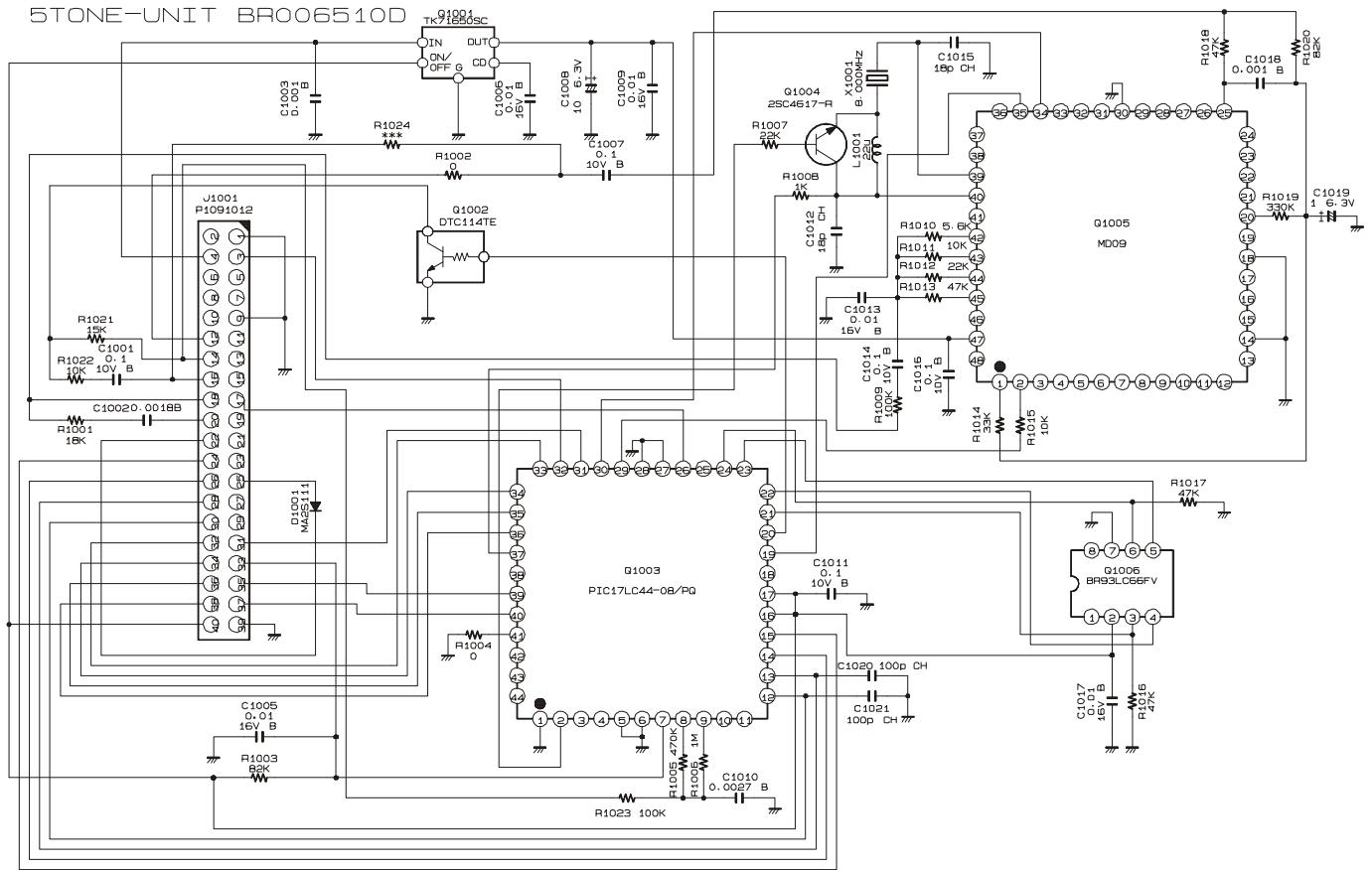

## Parts Layout

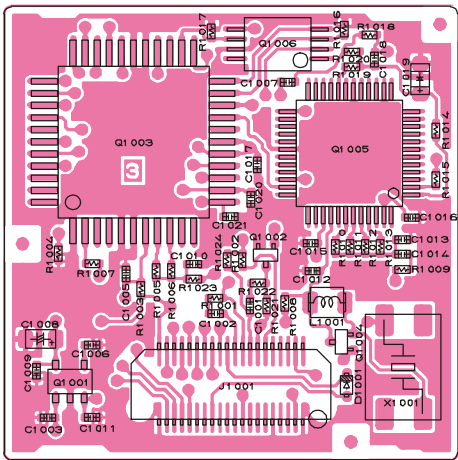

Side A

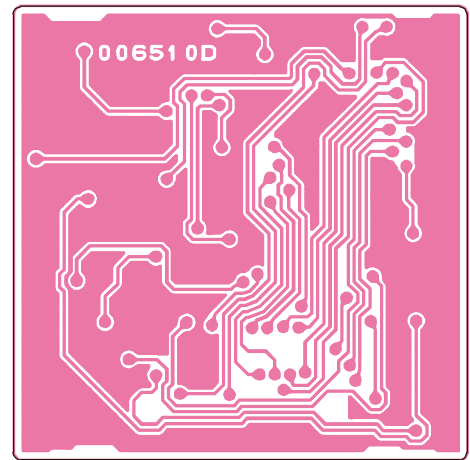

Side B

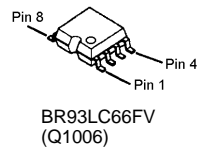
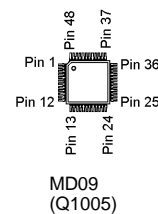
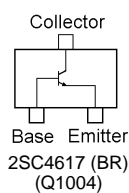
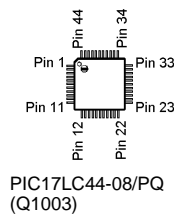
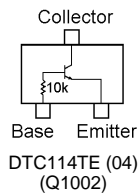
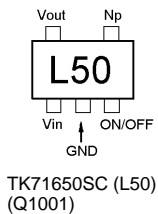

# F5D-14 5-Tone Unit

## Parts List

REF.	DESCRIPTION	VALUE	V/W	TOL.	MFR'S DESIG	VXSTD P/N	VERS.	LOT.	SIDE	LAY ADR
*** F5D-14 ***										
Printed Circuit Board						FR006510B		1-		
Printed Circuit Board						FR006510D		3-		
C 1001	CHIP CAP.	0.1uF	10V	B	GRM36B104K10PT	K22108802		1-	A	
C 1002	CHIP CAP.	0.0018uF	50V	B	GRM36B182K50PT	K22178812		1-	A	
C 1003	CHIP CAP.	0.001uF	50V	B	GRM36B102K50PT	K22178809		1-	A	
C 1005	CHIP CAP.	0.01uF	16V	B	GRM36B103K16PT	K22128804		1-	A	
C 1006	CHIP CAP.	0.01uF	16V	B	GRM36B103K16PT	K22128804		1-	A	
C 1007	CHIP CAP.	0.1uF	10V	B	GRM36B104K10PT	K22108802		1-	A	
C 1008	CHIP TA.CAP.	10uF	6.3V		EEJK0JS106R	K78080079		1-	A	
C 1008	CHIP TA.CAP.	10uF	6.3V		ECST0JZ106R	K78080078		8-	A	
C 1009	CHIP CAP.	0.01uF	16V	B	GRM36B103K16PT	K22128804		1-	A	
C 1010	CHIP CAP.	0.0027uF	50V	B	GRM36B272K50PT	K22178814		1-	A	
C 1011	CHIP CAP.	0.1uF	10V	B	GRM36B104K10PT	K22108802		1-	A	
C 1012	CHIP CAP.	18pF	50V	CH	GRM36CH180J50PT	K22178218		1-	A	
C 1013	CHIP CAP.	0.01uF	16V	B	GRM36B103K16PT	K22128804		1-	A	
C 1014	CHIP CAP.	0.1uF	10V	B	GRM36B104K10PT	K22108802		1-	A	
C 1015	CHIP CAP.	18pF	50V	CH	GRM36CH180J50PT	K22178218		1-	A	
C 1016	CHIP CAP.	0.1uF	10V	B	GRM36B104K10PT	K22108802		1-	A	
C 1017	CHIP CAP.	0.01uF	16V	B	GRM36B103K16PT	K22128804		1-	A	
C 1018	CHIP CAP.	0.001uF	50V	B	GRM36B102K50PT	K22178809		1-	A	
C 1019	CHIP TA.CAP.	1uF	6.3V		TMCP0J105MTR	K78080071		1-	A	
C 1020	CHIP CAP.	100pF	50V	CH	GRM36CH101J50PT	K22178236		1-	A	
C 1021	CHIP CAP.	100pF	50V	CH	GRM36CH101J50PT	K22178236		1-	A	
D 1001	DIODE				MA2S111-(TX)	G2070614		1-	A	
J 1001	CONNECTOR				AXK5S40035P	P1091012		1-	A	
L 1001	M.RFC	22uH			ELJ-FC220K	L1690201		1-	A	
Q 1001	IC				TK71650SCL	G1093136		1-	A	
Q 1002	TRANSISTOR				DTC114TE TL	G3070225		1-	A	
Q 1003	IC				PIC17LC44-08/PQ	S8100917		1-	A	
Q 1004	TRANSISTOR				2SC4617 TL R	G3346178R		1-	A	
Q 1005	IC				MD09	G1093276		1-	A	
Q 1006	IC				BR93LC66FV-E2	G1092853		1-	A	
R 1001	CHIP RES.	18k	1/16W	5%	RMC1/16S 183JTH	J24189040		1-	A	
R 1002	CHIP RES.	0	1/16W	5%	RMC1/16S JPTH	J24189070		1-	A	
R 1003	CHIP RES.	82k	1/16W	5%	RMC1/16S 823JTH	J24189048		1-	A	
R 1004	CHIP RES.	0	1/16W	5%	RMC1/16S JPTH	J24189070		1-	A	
R 1005	CHIP RES.	470k	1/16W	5%	RMC1/16S 474JTH	J24189057		1-	A	
R 1006	CHIP RES.	1M	1/16W	5%	RMC1/16S 105JTH	J24189061		1-	A	
R 1007	CHIP RES.	22k	1/16W	5%	RMC1/16S 223JTH	J24189041		1-	A	
R 1008	CHIP RES.	1k	1/16W	5%	RMC1/16S 102JTH	J24189025		1-	A	
R 1009	CHIP RES.	100k	1/16W	5%	RMC1/16S 104JTH	J24189049		1-	A	
R 1010	CHIP RES.	5.6k	1/16W	5%	RMC1/16S 562JTH	J24189034		1-	A	
R 1011	CHIP RES.	10k	1/16W	5%	RMC1/16S 103JTH	J24189037		1-	A	
R 1012	CHIP RES.	22k	1/16W	5%	RMC1/16S 223JTH	J24189041		1-	A	
R 1013	CHIP RES.	47k	1/16W	5%	RMC1/16S 473JTH	J24189045		1-	A	
R 1014	CHIP RES.	33k	1/16W	5%	RMC1/16S 333JTH	J24189043		1-	A	
R 1015	CHIP RES.	10k	1/16W	5%	RMC1/16S 103JTH	J24189037		1-	A	
R 1016	CHIP RES.	47k	1/16W	5%	RMC1/16S 473JTH	J24189045		1-	A	
R 1017	CHIP RES.	47k	1/16W	5%	RMC1/16S 473JTH	J24189045		1-	A	
R 1018	CHIP RES.	47k	1/16W	5%	RMC1/16S 473JTH	J24189045		1-	A	
R 1019	CHIP RES.	330k	1/16W	5%	RMC1/16S 334JTH	J24189055		1-	A	
R 1020	CHIP RES.	82k	1/16W	5%	RMC1/16S 823JTH	J24189048		1-	A	
R 1021	CHIP RES.	15k	1/16W	5%	RMC1/16S 153JTH	J24189039		1-	A	
R 1022	CHIP RES.	10k	1/16W	5%	RMC1/16S 103JTH	J24189037		1-	A	
R 1023	CHIP RES.	100k	1/16W	5%	RMC1/16S 104JTH	J24189049		1-	A	
X 1001	XTAL 94SMX	8MHZ			8.000MHZ	H0103248		1-	A	
	BLIND SHEET					RA0109300		1-		



# FVP-25 Encryption / DTMF Pager Unit

## Circuit Diagram

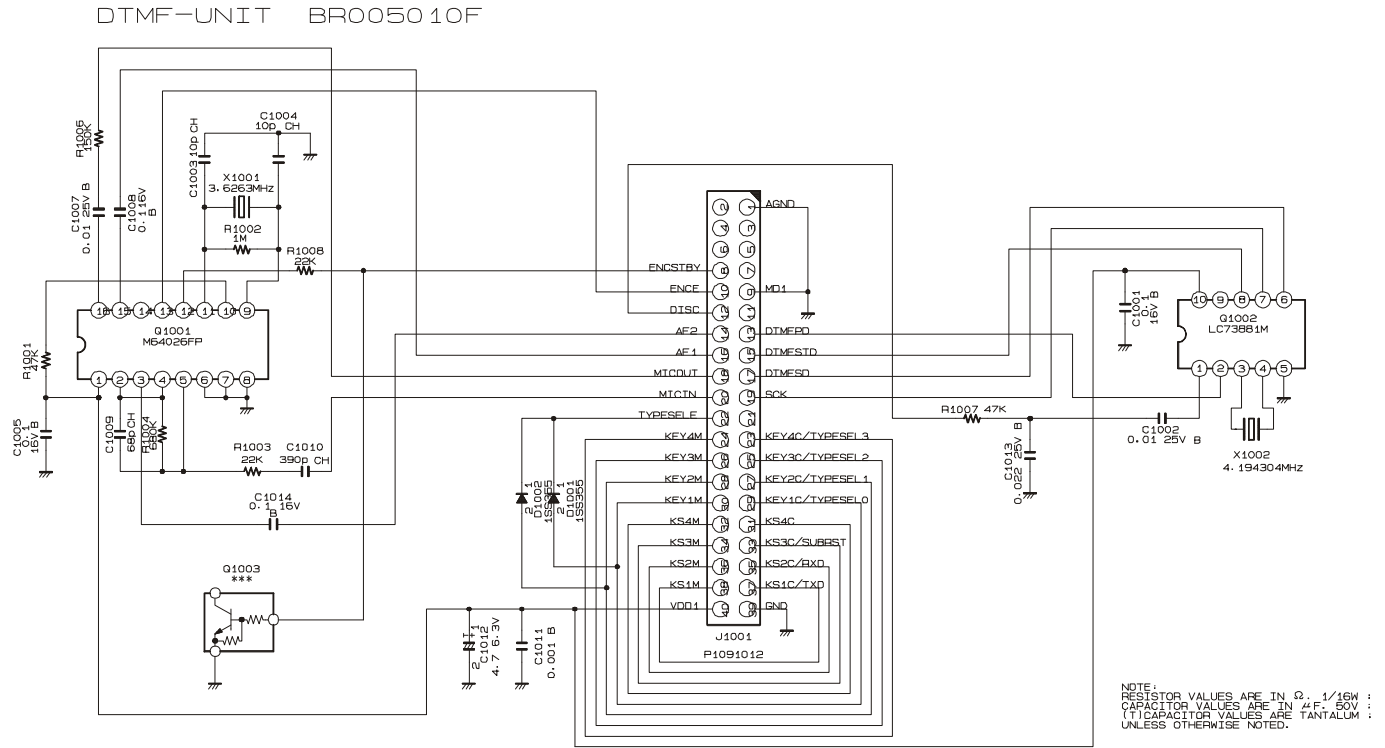

## Parts Layout

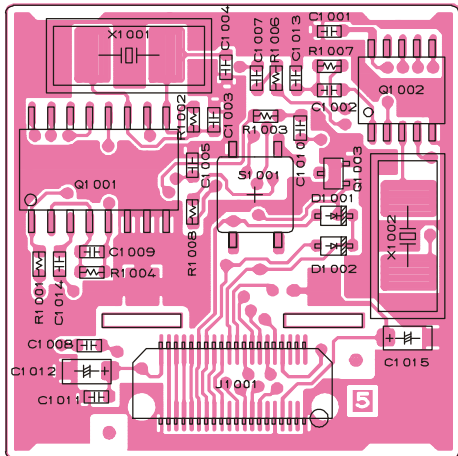

Side A

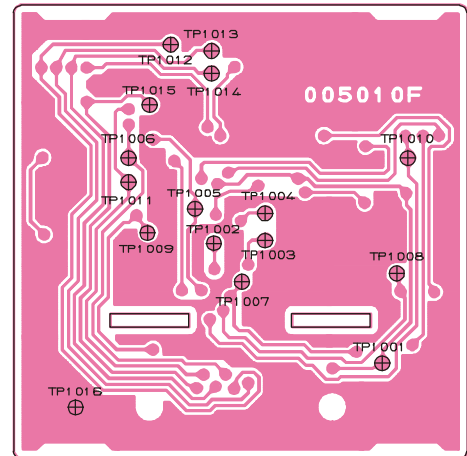

Side B

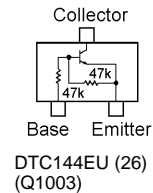
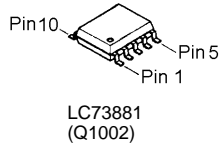
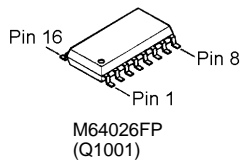

# FVP-25 Encryption / DTMF Pager Unit

## Parts List

REF.	DESCRIPTION	VALUE	V/W	TOL.	MFR'S DESIG	VXSTD P/N	VERS.	LOT.	SIDE	LAY ADR
*** FVP-25 ***										
Printed Circuit Board						FR005010F		1-		
C 1001	CHIP CAP.	0.1uF	16V	B	GRM39B104K16PT	K22124805		1-	A	B1
C 1002	CHIP CAP.	0.01uF	25V	B	GRM39B103M25PT	K22144802		1-	A	B1
C 1003	CHIP CAP.	10pF	50V	CH	GRM39CH100D50PT	K22174211		1-	A	A1
C 1004	CHIP CAP.	10pF	50V	CH	GRM39CH100D50PT	K22174211		1-	A	A1
C 1005	CHIP CAP.	0.1uF	16V	B	GRM39B104K16PT	K22124805		1-	A	A1
C 1007	CHIP CAP.	0.1uF	16V	B	GRM39B104K16PT	K22124805		1-	A	A1
C 1007	CHIP CAP.	0.01uF	25V	B	GRM39B103M25PT	K22144802		32-	A	A1
C 1008	CHIP CAP.	0.1uF	16V	B	GRM39B104K16PT	K22124805		1-	A	A2
C 1009	CHIP CAP.	68pF	50V	CH	GRM39CH680J50PT	K22174231		1-	A	A1
C 1010	CHIP CAP.	390pF	50V	CH	GRM39CH391J50PT	K22174255		1-	A	A1
C 1011	CHIP CAP.	0.001uF	50V	B	GRM39B102K50PT	K22174821		1-	A	A2
C 1012	CHIP TA.CAP.	4.7uF	6.3V		TEMSVA0J475M-8R	K78080017		1-	A	A2
C 1013	CHIP CAP.	0.022uF	25V	B	GRM39B223K25PT	K22144807		1-	A	A1
C 1014	CHIP CAP.	0.1uF	16V	B	GRM39B104K16PT	K22124805		1-	A	A1
D 1001	DIODE				1SS355 TE-17	G2070470		1-	A	B1
D 1002	DIODE				1SS355 TE-17	G2070470		1-	A	B1
J 1001	CONNECTOR				AXK5S40035P	P1091012		1-	A	A2
Q 1001	IC				M64026FP-650C	G1092754		1-	A	A1
Q 1002	IC				LC73881M-TLM	G1092755		1-	A	B1
Q 1003	TRANSISTOR				DTC144EU T106	G3070041		1-	A	B1
R 1001	CHIP RES.	47k	1/16W	5%	RMC1/16 473JATP	J24185473		1-	A	A1
R 1002	CHIP RES.	1M	1/16W	5%	RMC1/16 105JATP	J24185105		1-	A	A1
R 1003	CHIP RES.	22k	1/16W	5%	RMC1/16 223JATP	J24185223		1-	A	A1
R 1004	CHIP RES.	680k	1/16W	5%	RMC1/16 684JATP	J24185684		1-	A	A1
R 1006	CHIP RES.	150k	1/16W	5%	RMC1/16 154JATP	J24185154		1-	A	A1
R 1007	CHIP RES.	47k	1/16W	5%	RMC1/16 473JATP	J24185473		1-	A	B1
R 1008	CHIP RES.	10k	1/16W	5%	RMC1/16 103JATP	J24185103		1-	A	A1
R 1008	CARBON FILM RES.	22k	1/8W	5%	RD18TJ223 22K	J01215223		14-	A	A1
R 1008	CHIP RES.	22k	1/16W	5%	RMC1/16 223JATP	J24185223		17-	A	A1
X 1001	XTAL SX-1315	3.6263MHz			3.6263MHZ	H0103183		1-	A	A1
X 1002	XTAL SX-1315	4.194304MHz			4.194304MHZ	H0103184		1-	A	B1
	BLIND SHEET					RA0109300		1-		

# VTP-50 VX-Trunk Unit

## Circuit Diagram

VX-TRUNK-UNIT BR002540C

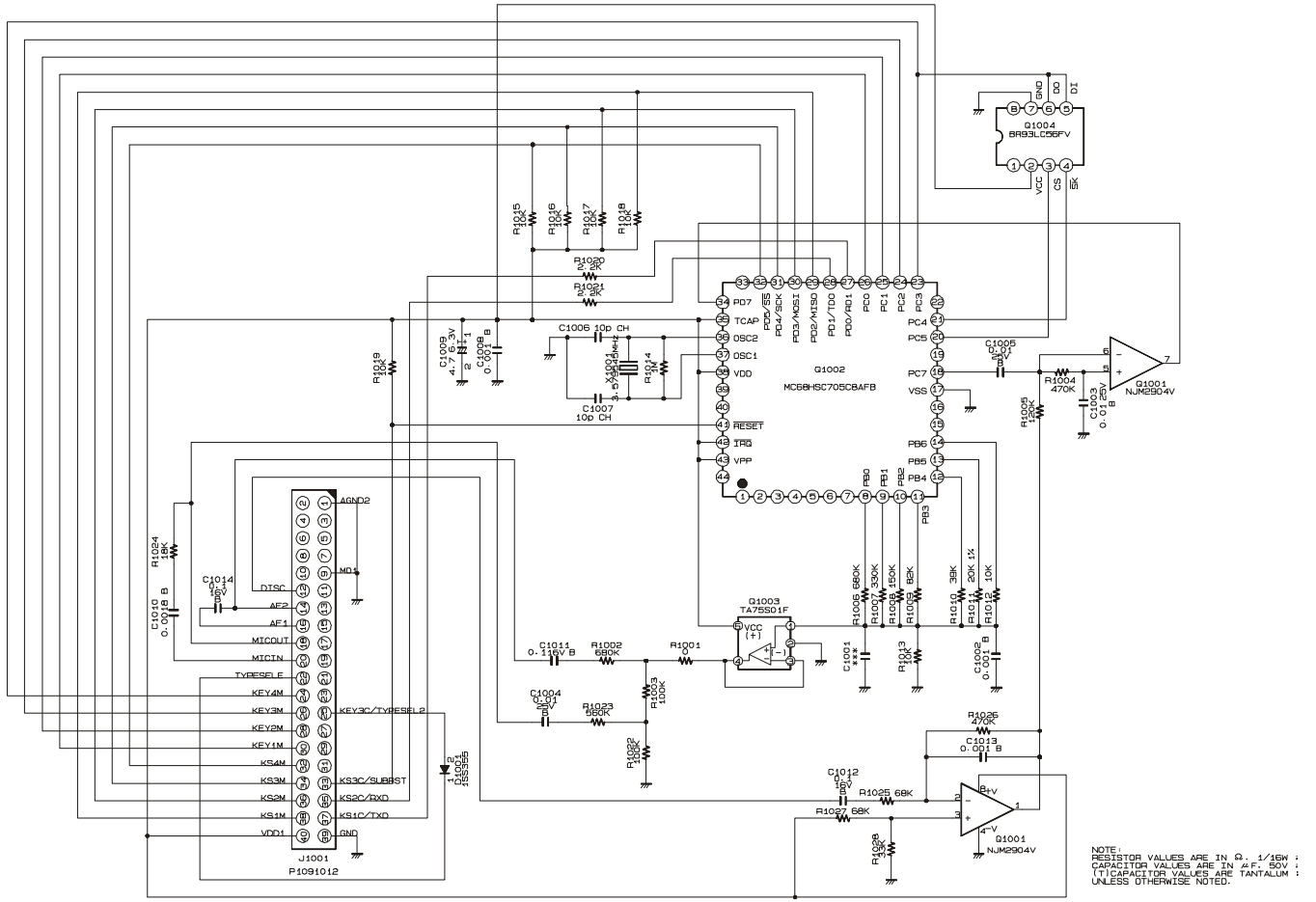

## Parts Layout

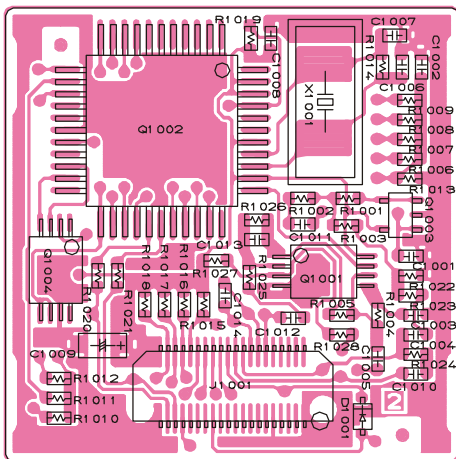

Side A

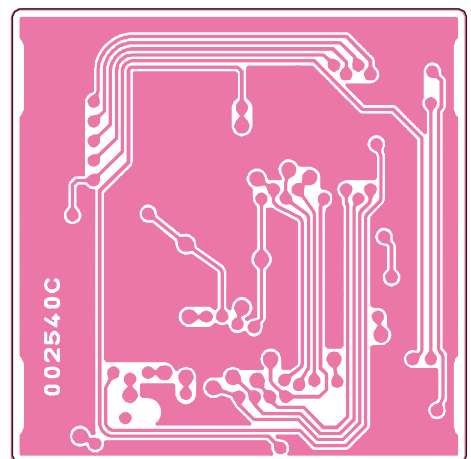

Side B

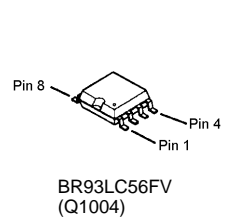
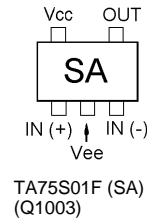
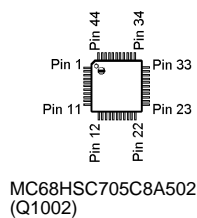
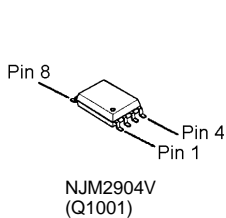

# VTP-50 VX-Trunk Unit

## Parts List

REF.	DESCRIPTION	VALUE	V/W	TOL.	MFR'S DESIG	VXSTD P/N	VERS.	LOT.	SIDE	LAY ADR
*** VTP-50 ***										
Printed Circuit Board						FR002540C		1-		
C 1002	CHIP CAP.	0.001uF	50V	B	GRM39B102K50PT	K22174821		1-	A	
C 1003	CHIP CAP.	0.01uF	25V	B	GRM39B103M25PT	K22144802		1-	A	
C 1003	CHIP CAP.	0.01uF	25V	B	GRM39B103K25PT	K22144803		9-	A	
C 1004	CHIP CAP.	0.1uF	16V	B	GRM39B104K16PT	K22124805		1-	A	
C 1004	CHIP CAP.	0.01uF	25V	B	GRM39B103K25PT	K22144803		9-	A	
C 1005	CHIP CAP.	0.01uF	25V	B	GRM39B103M25PT	K22144802		1-	A	
C 1005	CHIP CAP.	0.01uF	25V	B	GRM39B103K25PT	K22144803		9-	A	
C 1006	CHIP CAP.	10pF	50V	CH	GRM39CH100C50PT	K22174248		1-	A	
C 1007	CHIP CAP.	10pF	50V	CH	GRM39CH100C50PT	K22174248		1-	A	
C 1008	CHIP CAP.	0.001uF	50V	B	GRM39B102K50PT	K22174821		1-	A	
C 1009	CHIP TA.CAP.	4.7uF	6.3V		TEMSVA0J475M-8R	K78080017		1-	A	
C 1010	CHIP CAP.	0.0018uF	50V	B	GRM39B182M50PT	K22174812		1-	A	
C 1011	CHIP CAP.	0.1uF	16V	B	GRM39B104K16PT	K22124805		1-	A	
C 1012	CHIP CAP.	0.1uF	16V	B	GRM39B104K16PT	K22124805		1-	A	
C 1013	CHIP CAP.	0.001uF	50V	B	GRM39B102K50PT	K22174821		1-	A	
C 1014	CHIP CAP.	0.1uF	16V	B	GRM39B104K16PT	K22124805		1-	A	
D 1001	DIODE				1SS355 TE-17	G2070470		1-	A	
J 1001	CONNECTOR				AXK5S40035P	P1091012		1-	A	
Q 1001	IC				NJM2904V-TE1	G1091677		1-	A	
Q 1002	IC				MC68HSC705C8A502-6030 130	G1092917		1-	A	
Q 1002	IC				MC68HSC705C8A502-6030 131	G1093326		6-	A	
Q 1003	IC				TA75S01F TE85R	G1091593		1-	A	
Q 1004	IC				BR93LC56FV-E2	G1092787		1-	A	
R 1001	CHIP RES.	0	1/16W	5%	RMC1/16 000JATP	J24185000		1-	A	
R 1002	CHIP RES.	680k	1/16W	5%	RMC1/16 684JATP	J24185684		1-	A	
R 1003	CHIP RES.	100k	1/16W	5%	RMC1/16 104JATP	J24185104		1-	A	
R 1004	CHIP RES.	470k	1/16W	5%	RMC1/16 474JATP	J24185474		1-	A	
R 1005	CHIP RES.	120k	1/16W	5%	RMC1/16 124JATP	J24185124		1-	A	
R 1006	CHIP RES.	680k	1/16W	5%	RMC1/16 684JATP	J24185684		1-	A	
R 1007	CHIP RES.	330k	1/16W	5%	RMC1/16 334JATP	J24185334		1-	A	
R 1008	CHIP RES.	150k	1/16W	5%	RMC1/16 154JATP	J24185154		1-	A	
R 1009	CHIP RES.	82k	1/16W	5%	RMC1/16 823JATP	J24185823		1-	A	
R 1010	CHIP RES.	39k	1/16W	5%	RMC1/16 393JATP	J24185393		1-	A	
R 1011	CHIP RES.	20k	1/16W	1%	RMC1/16 203FTP	J24183203		1-	A	
R 1012	CHIP RES.	10k	1/16W	5%	RMC1/16 103JATP	J24185103		1-	A	
R 1013	CHIP RES.	10k	1/16W	5%	RMC1/16 103JATP	J24185103		1-	A	
R 1014	CHIP RES.	1M	1/16W	5%	RMC1/16 105JATP	J24185105		1-	A	
R 1015	CHIP RES.	10k	1/16W	5%	RMC1/16 103JATP	J24185103		1-	A	
R 1016	CHIP RES.	10k	1/16W	5%	RMC1/16 103JATP	J24185103		1-	A	
R 1017	CHIP RES.	10k	1/16W	5%	RMC1/16 103JATP	J24185103		1-	A	
R 1018	CHIP RES.	10k	1/16W	5%	RMC1/16 103JATP	J24185103		1-	A	
R 1019	CHIP RES.	10k	1/16W	5%	RMC1/16 103JATP	J24185103		1-	A	
R 1020	CHIP RES.	2.2k	1/16W	5%	RMC1/16 222JATP	J24185222		1-	A	
R 1021	CHIP RES.	2.2k	1/16W	5%	RMC1/16 222JATP	J24185222		1-	A	
R 1022	CHIP RES.	100k	1/16W	5%	RMC1/16 104JATP	J24185104		1-	A	
R 1023	CHIP RES.	560k	1/16W	5%	RMC1/16 564JATP	J24185564		1-	A	
R 1024	CHIP RES.	18k	1/16W	5%	RMC1/16 183JATP	J24185183		1-	A	
R 1025	CHIP RES.	68k	1/16W	5%	RMC1/16 683JATP	J24185683		1-	A	
R 1026	CHIP RES.	470k	1/16W	5%	RMC1/16 474JATP	J24185474		1-	A	
R 1027	CHIP RES.	68k	1/16W	5%	RMC1/16 683JATP	J24185683		1-	A	
R 1028	CHIP RES.	33k	1/16W	5%	RMC1/16 333JATP	J24185333		1-	A	
X 1001	XTAL SX-1315	3.579545MHZ			3.579545MHZ	H0103185		1-	A	
	BLIND SHEET					RA0109300		1-		





**Copyright © 2002**

**VERTEX STANDARD CO., LTD.**

**All rights reserved**

No portion of this manual may be reproduced without the permission of VERTEX STANDARD CO., LTD.



Printed in Japan.