

INSTRUCTION BOOK FOR
MODEL 4022
RF DIRECTIONAL
THRULINE® POWER SENSOR

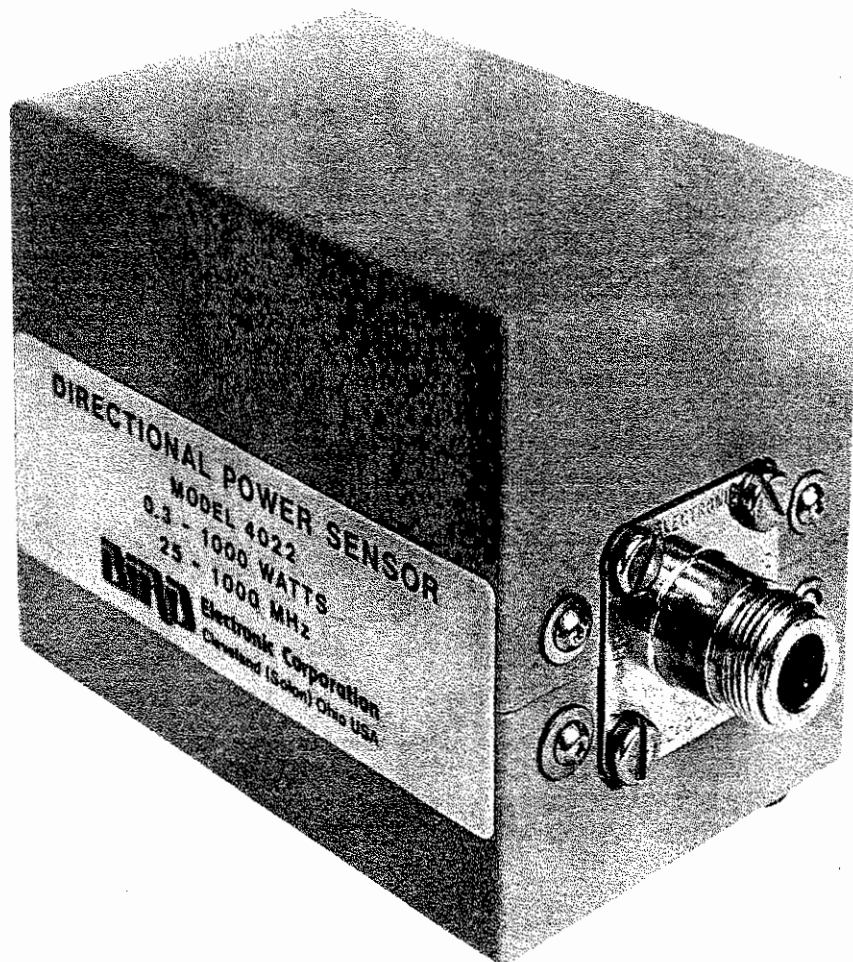

BIRD

Electronic Corporation

30303 Aurora Road, Cleveland [Solon] Ohio 44139-2794

©Copyright 1987 by Bird Electronic Corp.

SAFETY PRECAUTIONS

The following are general safety precautions that are not necessarily related to any specific part or procedure and do not necessarily appear elsewhere in this publication.

Keep away from live circuits.

Operating personnel must at all times observe normal safety regulations. Do not attempt to replace parts or disconnect a RF transmission or any other high voltage line while power is applied. When working with high voltage always have someone present who is capable of rendering aid if necessary. Personnel working with or near high voltage should be familiar with modern methods of resuscitation.

The following will appear in the text of this publication and is shown here for emphasis.

WARNING

NEVER ATTEMPT TO CONNECT OR DISCONNECT THE EQUIPMENT FROM THE TRANSMISSION LINE WHILE RF POWER IS BEING APPLIED. LEAKING RF ENERGY IS A POTENTIAL HEALTH HAZARD.

WARNING

PROVIDE ADEQUATE VENTILATION AND OBSERVE NORMAL PRECAUTIONS WHEN USING DRY CLEANING SOLVENTS. MANY DRY CLEANING AGENTS EMIT TOXIC FUMES THAT MAY BE HARMFUL TO YOUR HEALTH IF INHALED.

CAUTION

DO NOT APPLY RF POWER TO DIRECTIONAL POWER SENSOR WHICH EXCEEDS 120% OF FULL SCALE OF HIGHEST RANGE.

CAUTION

TRANSMITTED TRAVELING WAVES SHOULD ALWAYS BE APPLIED TO SOURCE INPUT OF POWER SENSOR. APPLYING TRAVELING WAVES TO LOAD PORT WILL RESULT IN AN ERRONEOUS DISPLAY.

CAUTION

4420 SERIES RF POWER METER MUST BE TURNED OFF WHEN MAKING CONNECTIONS OR DISCONNECTIONS BETWEEN POWER METER AND POWER SENSOR.

CAUTION

DO NOT OPERATE POWER SENSOR INTO A LOAD WITH VSWR GREATER THAN 2:1.

TABLE OF CONTENTS

	Page
SAFETY PRECAUTIONS	1
INTRODUCTION	
General	3
Descriptions	3
SECTION I — INSTALLATION	
Unpacking and Inspection	5
Connections	5
SECTION II — OPERATION	
General	7
SECTION III — MAINTENANCE	
General	7
Troubleshooting	7
Calibration	7
Customer Service	7
Repackaging	7
SECTION IV — SPARE PARTS	
General	7
ILLUSTRATIONS	
Model 4022 Outline	3
Basic Power Sensor Connection	5
Sensor Cable Connection	6
TABLES	
Specifications	4

MODEL 4022 RF DIRECTIONAL THRULINE® POWER SENSOR

INTRODUCTION

GENERAL

This publication refers to the Model 4022 which is a member of the Bird 4020 Series of directional power sensors. Other power sensors are available in different power and frequency ranges. For more information contact Bird Electronic Corporate Headquarters, Solon, OH.

DESCRIPTIONS

The Model 4022 is not a stand alone unit, but is considered part of the 4420 Series RF Power Meter system for RF power measurement. The Model 4022 Directional Power Sensor is an insertion type THRU-LINE® device designed to simultaneously measure forward and reflected power in 50 ohm coaxial transmission systems. It is designed and intended for use on CW unmodulated or FM signals only.

The Model 4022 Power Sensor, see Figure I-1, is contained within a steel enclosure with four rubber shock feet mounted to the base.

At each end of the sensor are Bird Quick-Change type RF connectors, which can be quickly interchanged with any other Bird "QC" connector by removing four screws on the mounting flanges.

In normal operation, the power sensor is connected to the power meter via a sensor cable, whose purpose it is to provide a path for serial data communication between the power sensor and the power meter. Note that the cable interconnect at the power sensor is recessed in order to prevent accidental damage.

Two labels affixed to the sides of the power sensor indicate power range, frequency band and direction of applied traveling wave.

Figure I-1. Model 4022 Outline.

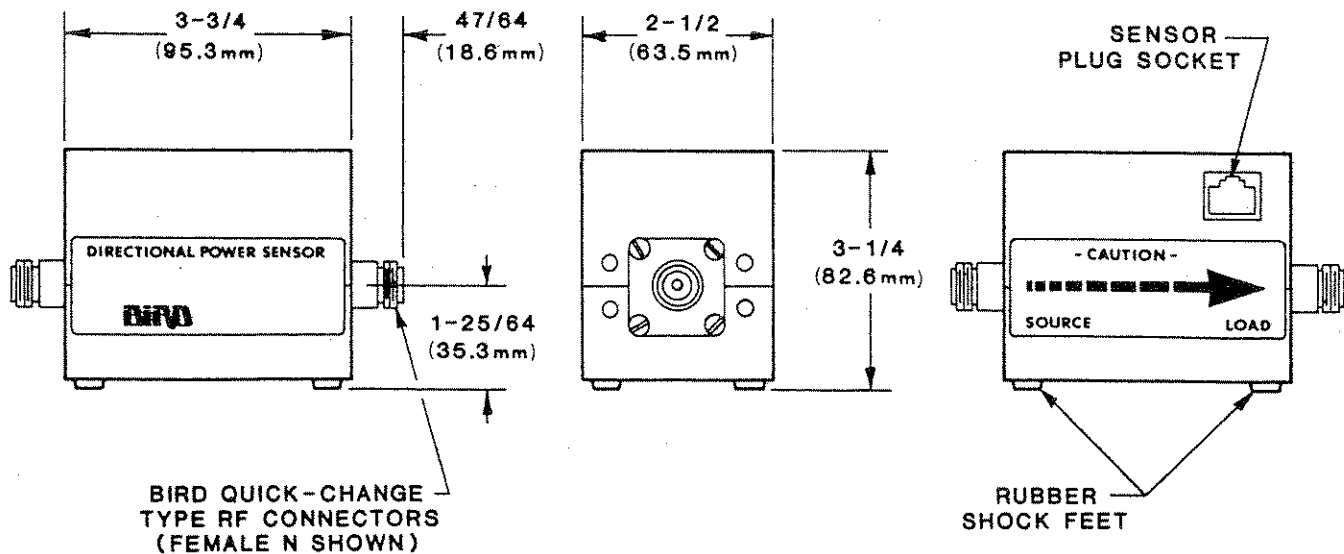

SPECIFICATIONS FOR MODEL 4022 RF DIRECTIONAL THRULINE® POWER SENSOR

Type	THRULINE® design for direct insertion in 50-ohm line
Circuitry	Microprocessor-based measurement and conversion
Power Input Range	300mW-1000W (1200W maximum)
Frequency Range	25MHz to 1000MHz
VSWR Range	1.00 to 2.00 (40.0 to 9.5dB return loss)
Accuracy¹	
FWD ²	±3% of reading
RFL ³	±3% of reading + $\left(\frac{\text{Fwd Pwr}}{1000}\right)$
VSWR ⁴	Power measurement dependent
Impedance	50 ohms nominal
Insertion VSWR	
25-512MHz	1.05 maximum (32.3dB return loss)
512-1000MHz	1.10 maximum (26.4dB return loss)
Insertion loss	
25-512MHz	< .05dB
512-1000MHz	< .13dB
Minimum Directivity	30dB
Sampling Rate	Approximately 2 readings/second
Calibration Technique	Calibration vs. frequency curve stored in non-volatile memory within each sensor. Sensor output corrected at frequency of measurement within rated range
Temperature Range	
Operating	Temperature compensated for rated accuracy from 0°C to 50°C (32°F to 122°F)
Storage	-20°C to +70°C (-4°F to +158°F)
Connectors	"QC" type Female N normally supplied; 25 other coaxial-type connectors available
Nominal Size	Including connectors ⁵ 5 ⁷ / ₃₂ " × 3 ¹ / ₄ " × 2 ¹ / ₂ " (120 × 76 × 64mm)
Electrical Length	5.4" (137.1 mm) (with Female N connectors)
Weight	1 lb. 11 oz. (0.75kg)
Power	Supplied by power meter via sensor cable

¹ For rated accuracy no more than 1% AM; harmonics -50dBc or less; terminating VSWR 2:1 or less.

² Forward power is defined as power traveling from the source to the load. Measurement accuracy is referenced to the load connector.

³ Reflected power is defined as power traveling from the load to the source. Measurement accuracy is referenced to the source connector.

⁴ Calculated from forward and reflected power.

⁵ 5⁷/₃₂" dimension will vary with use of different Bird "QC" type connectors.

SECTION I — INSTALLATION

1-1. UNPACKING AND INSPECTION

1-2. All packages are carefully inspected prior to shipment. If package shows any sign of damage, promptly inspect the device. If any damage is visible, notify the carrier immediately. Retain the shipping container for inspection.

1-3. CONNECTIONS

WARNING

NEVER ATTEMPT TO CONNECT OR DISCONNECT THE EQUIPMENT FROM THE TRANSMISSION LINE WHILE RF POWER IS BEING APPLIED. LEAKING RF ENERGY IS A POTENTIAL HEALTH HAZARD.

CAUTION

TRANSMITTED TRAVELING WAVES SHOULD ALWAYS BE APPLIED TO SOURCE INPUT OF POWER SENSOR. APPLYING TRAVELING WAVES TO LOAD PORT WILL RESULT IN AN ERRONEOUS DISPLAY.

CAUTION

DO NOT APPLY RF POWER TO DIRECTIONAL POWER SENSOR WHICH EXCEEDS 120% OF FULL SCALE OF HIGHEST RANGE.

CAUTION

DO NOT OPERATE POWER SENSOR INTO A LOAD WITH VSWR GREATER THAN 2:1.

1.4. The simplified example in Figure 1-1 shows the basic insertion of Model 4022 Power Sensor into a 50 ohm transmission line. Care should be taken to insure proper connection of source and load ports.

1.5. A communication channel must now be established between the power sensor and power meter. This is accomplished via the sensor cable, P/N 4421-038.

CAUTION

4420 SERIES RF POWER METER MUST BE TURNED OFF WHEN MAKING CONNECTIONS OR DISCONNECTIONS BETWEEN POWER METER AND POWER SENSOR.

1.6. Insert cable plug such that latching mechanism aligns with groove of socket. Apply a minimal amount of forward force until latch mechanism engages into locking position, see Figure 1-2. Repeat same procedure when connecting cable to rear of power meter.

1.7. If sensor cable needs to be removed at any time, it is only necessary to depress latch and remove cable plug.

Figure 1-1. Basic Power Sensor Connection.

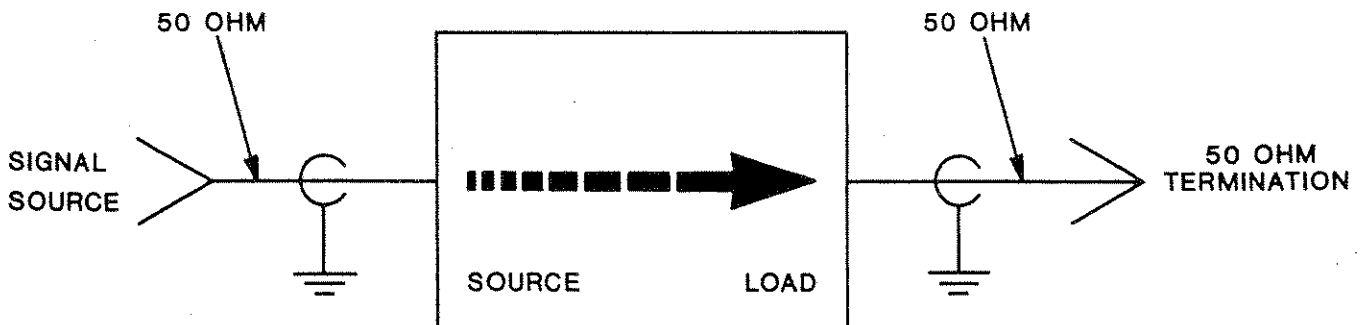
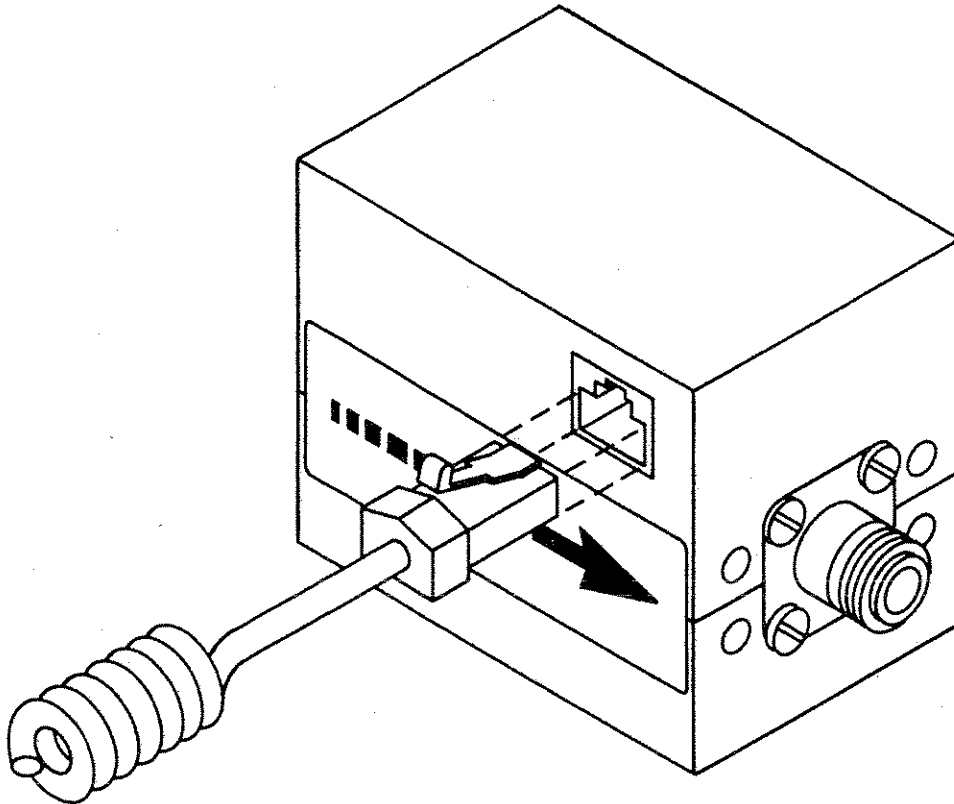

Figure 1-2. Sensor Cable Connection.



SECTION II — OPERATION

2.1. GENERAL

2.2. The 4022 Power Sensors' operation is self-maintaining and responds directly to the commands of the power meter. There are no adjustments or operator interfacing required for normal operation.

2.3. It is very important that the operator be completely familiar with the command and operating procedures of the power meter (consult 4420 Series RF Power Meter instruction book).

SECTION III — MAINTENANCE

3.1. GENERAL

3.2. Model 4022 Power Sensor requires only simple and routine maintenance.

- a. Avoid subjecting the power sensor to rough treatment.
- b. Keep the RF connectors covered when not in use. This will prevent dust and dirt from accumulating in the connectors.
- c. Wipe off dust and dirt regularly.

WARNING

PROVIDE ADEQUATE VENTILATION AND OBSERVE NORMAL PRECAUTIONS WHEN USING DRY CLEANING SOLVENTS. MANY DRY CLEANING AGENTS EMIT TOXIC FUMES THAT MAY BE HARMFUL TO YOUR HEALTH IF INHALED.

- d. RF Connectors — Clean RF connectors with a cotton swab stick dampened with alcohol, freon or any acceptable dry cleaning solvent.
- e. Sensor cable connector — Connector should be cleaned frequently with alcohol. Be sure to check connector pins for damage.

3.3. TROUBLESHOOTING

3.4. Due to its complexity and warranty, repair of power sensor head beyond general maintenance is not recommended. Power Sensor should be returned to Bird Electronic Corporation for repair or calibration. For this reason, removal or disturbance of power sensor covers is not recommended, and will result in cancellation of lifetime warranty.

4022

3.5. CALIBRATION

3.6. Each power sensor has been individually calibrated to minimize error contribution due to frequency. A calibration vs. frequency curve stored in non-volatile memory is within sensor. This eliminates need for internal adjustments.

3.7. If a power sensor needs recalibration, it is only necessary to contact your nearest authorized Bird Calibration center or Bird Electronic Corporate Headquarters.

3.8. CUSTOMER SERVICE

3.9. Bird Electronic Corporation maintains a complete repair and calibration department at our corporate headquarters. This department is set up to provide the best possible service of Bird equipment.

3.10. All instruments returned for service must be shipped prepaid and to the attention of the Customer Service Group.

Bird Electronic Corporation
30303 Aurora Road
Cleveland (Solon), OH 44139
Phone: 216-248-1200
Cable: BIRDELEC
Telex: 706898 Bird Elec UD

3.11. REPACKAGING

3.12. Should you need to return the unit, use the original shipping package if possible. If the original package is not available, use heavy duty corrugated box with shock-absorbing material around all sides of the unit to provide firm cushion and prevent movement in container. Container should be properly sealed.

SECTION IV — SPARE PARTS

4.1. GENERAL

4.2. The only field replaceable parts on the 4020 Series Power Sensors are the QC type RF connectors. Bird offers a complete selection of different connectors, all of them incorporating the QC interchange format. Please contact the factory regarding these connectors.