

CenturyLink Technical Publication

Grounding - Central Office and Remote Electronic Equipment Environments

NOTICE

This publication presents CenturyLink's view of the generic requirements or guidelines that describe grounding methods for metallic frames and electrical power supplies associated with Central Office (CO) Switching Equipment, Remote Switch Units or Modules (RSV/RSV), Storage Program Control Switching Systems (SPECs) both analog and digital, or other telecommunications equipment that is installed within a building, normally referred to as a Central Office buildings or Remote Equipment Enclosures.

CenturyLink reserves the right to revise this document for any reason, including but not limited to, conformity with standards promulgated by various governmental or regulatory agencies; utilization of advances in the state of the technical arts; or to reflect changes in the design of equipment, techniques, or procedures described or referred to herein.

Liability to anyone arising out of use or reliance upon any information set forth herein is expressly disclaimed, and no representation or warranties, expressed or implied, are made with respect to the accuracy or utility of any information set forth herein.

This document is not to be construed as a suggestion to any manufacturer to modify or change any of its products, nor does this publication represent any commitment by CenturyLink to purchase any specific products. Further, conformance to this publication does not constitute a guarantee of a given supplier's equipment and/or its associated documentation.

Ordering information for CenturyLink Technical Publications can be obtained from the Reference Section of this document.

COMMENTS

PLEASE TEAR OUT AND SEND YOUR COMMENTS/SUGGESTIONS TO:

CenturyLink
Local Network Power Tech Support
700 W. Mineral, MT-H22.13
Littleton, CO 80210
(303) 707-5699
fax: (303) 707-9041
Curtis.Ashton@CenturyLink.com

Information from you helps us to improve our Publications. Please take a few moments to answer the following questions and return to the above address.

Was this Publication valuable to you in determining our requirements? YES _____ NO _____

Was the information accurate and up-to-date? YES _____ NO _____

Was the information easily understood? YES _____ NO _____

Were the contents logically sequenced? YES _____ NO _____

Were the printed pages legible? YES _____ NO _____

If you answered NO to any of the questions and/or if you have any other comments or suggestions, please explain:

(Attach additional sheet, if necessary)

Name _____ Date _____

Company _____

Address _____

Telephone Number _____

Email _____

CONTENTS

Chapter and Section	Page
1. Introduction	1-1
1.1 General.....	1-1
1.2 Cross-Reference of Terminology	1-1
2. General Requirements.....	2-1
2.1 Reasons for proper AC and DC Grounding	2-1
2.1.1 Personnel Safety	2-1
2.1.2 Equipment and Distribution Circuit Protection.....	2-1
2.1.3 Electrostatic Discharges (ESD)	2-1
2.1.4 Reliability	2-1
2.1.5 Equipment Operation.....	2-1
2.1.6 Noise Reduction.....	2-1
2.2 Minimizing Grounding and Bonding Impedance	2-2
3. Building Ground Requirements	3-1
3.1 Ground Electrodes	3-1
3.2 Acceptable Methods	3-3
3.2.1 Ground Ring.....	3-3
3.2.2 Deep Driven Rod.....	3-5
3.2.3 Ground Grid or Array	3-7
3.2.4 Counterpoise.....	3-7
3.2.5 Well Casings	3-7
3.2.6 Deep Well Ground.....	3-8
3.2.7 Backfilled Wells.....	3-8
3.2.8 Supplemental Grounding Electrodes.....	3-8
3.3 Materials.....	3-10
3.3.1 Ground Rods.....	3-10
3.3.2 Exterior Ground Wire.....	3-13
3.3.3 Interior Ground Wire	3-15
3.3.4 Connectors	3-17
3.4 Connections	3-19
3.5 Main Site Ground Bus (OPGP, SPGP, or PANI MGB)	3-19
3.6 Identification of Grounding Conductors.....	3-20
3.7 Design Parameters of Vertical Equalizer System	3-21
3.8 Design Parameters of Horizontal Equalizer System.....	3-21
3.9 CO GRD System Raceway Application.....	3-24
3.10 Grounding and AC Feeds for Separate Buildings.....	3-24

CONTENTS (Continued)

Chapter and Section	Page
4. AC Service Distribution and Equipment Ground Requirements	4-1
4.1 AC Neutral Conductor	4-1
4.2 AC Service Grounding of Separately Derived AC Systems	4-1
4.3 NEC Code Requirements	4-3
4.4 AC Service Grounding Electrode Conductor	4-6
4.5 AC Equipment Ground Conductor	4-8
4.6 CenturyLink AC Equipment Ground Requirements	4-10
4.7 AC Installation Requirements	4-11
4.8 Engine-Alternator Set(s)	4-11
4.9 Grounding for AC Standby Plants	4-12
4.10 Ground Fault Detection/Protection	4-14
4.11 Busduct System	4-17
4.12 AC Power Distribution Service Cabinets	4-17
4.13 AC Equipment Ground Busbars	4-17
4.14 Raceways	4-18
4.15 Lighting Distribution Systems	4-18
4.16 Cord Connected AC Operated Equipment	4-23
4.17 Frame Base Appliance Outlets	4-26
4.18 Trolley Type Busduct	4-26
4.19 Armored Cable	4-27
5. Integrated Ground Systems	5-1
5.1 Integrated Ground Plane	5-1
5.2 Buried Objects	5-1
5.3 Frame Grounding Methods	5-1
5.4 Integrated Ground Plane Loads	5-2
5.4.1 Frame Grounding and Return Bus Reference for DC Power Supplies	5-2
5.4.2 Loads Fed from the Principal DC Source	5-3
5.4.3 Loads Fed from Internal Power Sources	5-3
5.5 Grounding for Separately Derived DC and AC Power Supplies	5-3
5.5.1 Grounding Internal DC and AC Power Supplies	5-3
5.5.2 Two or More Power Sources	5-4

CONTENTS (Continued)

Chapter and Section	Page
5.6 Central Office (CO GRD) System	5-4
5.7 Design Parameters of a COGB	5-4
5.8 Equipment Frame Grounding	5-6
5.9 Equipment Frame Busbar Functions as a Combination Discharge-Framework Ground Busbar	5-8
5.10 Relay Rack "Frame Return" Ground Busbars	5-8
5.11 Distributing and Protector Frame Busbars	5-8
5.12 Collocated Local Exchange Carrier Grounding	5-9
5.12.1 The Grounding "Feed" for Caged Physical Collocation	5-9
5.12.2 Fence Grounding for Caged Physical Collocation	5-10
5.12.3 Isolated Ground Planes in Caged Physical Collocation	5-11
5.12.4 Grounding for Other Types of Collocation	5-15
6. Cable Entrance Facility (CEF)	6-1
6.1 Determining Exposure to Foreign Potentials	6-1
6.2 Central Office Protection	6-1
6.3 CEF Protection Measures (Bonding and Grounding)	6-2
6.4 Alternative Arrangements for Bonding and Grounding Optical Fiber Cables	6-3
6.5 Location of the CEF	6-4
6.6 Air Dryer Grounding	6-5
7. Radio Equipment Ground Systems and Rooftop Lightning Protection	7-1
7.1 Driven Ground Electrodes For Radio/Sites	7-1
7.2 Frame Grounding Methods	7-1
7.3 The Exterior Ring Ground System	7-2
7.4 Rooftop-Mounted Ring Grounds	7-3
7.5 Non-Metallic Antenna Structures	7-9
7.5.1 Metal Monopole Grounding	7-10
7.6 Waveguides and Transmission Lines	7-10
7.7 Tower Warning Lights	7-10
7.8 Metallic Feed Line Support Structure	7-11

CONTENTS (Continued)

Chapter and Section	Page
7.9 Waveguide Hatchplate Bonds.....	7-11
7.10 The Interior Ring Bus System.....	7-13
7.11 The Interior-Exterior Ring Bonds	7-15
7.12 Supplementary Ring Grounding	7-17
7.13 Forming and Support of the Interior Ring Ground	7-20
7.14 Forming and Support of Supplementary Buses	7-22
7.15 Miscellaneous Unit Bonding	7-22
7.16 Conduit, Pipe and Duct Bonding	7-23
7.17 Bonding of Units Outside the Ring Ground Periphery.....	7-24
7.18 Building Structural Member Bonding Requirements.....	7-24
7.19 Telecommunications Facilities at Radio Stations	7-26
7.20 Environmental Considerations - Mountain Top Installations.....	7-26
7.21 Frame and Power Plant Return Bus Bonding Requirements	7-26
7.22 Power Service	7-32
7.23 Grounding Issues Related to Cellular/PCS or WiMax Antennas, or Collocated Microwave Dishes.....	7-34
7.23.1 Lightning Protection for Wireless Antennas.....	7-34
7.23.2 Tying the CenturyLink and Wireless Ground Electrode Fields Together.....	7-36
7.23.3 Power Service Entrance Protection for Wireless Equipment.....	7-43
7.23.4 Protection for a Power Interface Between CenturyLink and a Wireless Provider	7-44
7.23.5 Protection for Other Cabling Interfaces Between CenturyLink and a Wireless Services Provider.....	7-45
7.23.6 Grounding for Collocated Microwave Facilities	7-46
7.24 GPS Antenna Grounding Issues	7-47
8. Isolated Ground	8-1
8.1 Isolated Ground Plane Principles	8-1
8.1.1 Isolated Ground Plane.....	8-1
8.1.2 Stored Program Control Frames.....	8-1
8.2 Interconnected Frames	8-2
8.3 Serial, Radial, and Mesh Grounding.....	8-2
8.4 Isolated Frame Grounding Methods.....	8-2
8.5 Power Supply Grounding Methods.....	8-6

CONTENTS (Continued)

Chapter and Section	Page
8.6 Multigrounded Power Source.....	8-6
8.7 DC Power Supplies.....	8-6
8.8 AC Power Supplies.....	8-8
8.9 General Isolated Grounding Conductor Requirements.....	8-9
8.10 Induction Effects.....	8-10
8.10.1 Loops in the Isolated Ground Plane.....	8-10
8.10.2 Lightning and Fault Current Carrying Members.....	8-10
8.10.3 Nearby Integrated Ground Plane Frames.....	8-10
8.11 Isolating Ground Plane Frames (Specific Requirements).....	8-11
8.11.1 Specific Requirements.....	8-11
8.11.2 Insulation Resistance.....	8-12
8.11.3 Frame to Frame Connections.....	8-12
8.11.4 Grounding Among Groups of Frames.....	8-14
8.11.5 Serial and Radial Connections Within the Isolated Plane.....	8-14
8.11.6 Limits on the Number of Floors an Isolated Ground Plane Can Occupy.....	8-14
8.11.7 Peripheral Equipment Frame Grounding.....	8-15
8.12 External Principal Power Plant Grounding Requirements.....	8-15
8.12.1 The Return Bus.....	8-15
8.12.2 Grounding the Return Bus.....	8-16
8.12.3 Grounding the Plant's Frame(s).....	8-16
8.12.4 Location of the Power Plant.....	8-16
8.12.5 Power Feeders.....	8-16
8.13 Integrated Ground Plane Loads.....	8-18
8.14 Loads Fed from Internal Power Sources.....	8-19
8.15 Grounding Internal DC and AC Power Supplies Within the Isolated Ground Plane.....	8-19
8.16 Grounding the External AC and DC Power Supplies Feeding Isolated Ground Plane Loads (Other Than the Principal Power Source).....	8-19
8.16.1 DC Power Supplies.....	8-19
8.16.2 AC Power Supplies.....	8-19
8.16.3 Treatment of the AC Conductors.....	8-20

CONTENTS (Continued)

Chapter and Section	Page
8.17 Specific Examples of AC and DC Grounding Principles for Isolated Ground Planes	8-20
8.18 Establishing a Ground Window	8-20
8.18.1 Dimensions	8-20
8.18.2 Location	8-21
8.18.3 Connections	8-21
8.19 Ground Window Configurations	8-21
8.19.1 Separate Ground Window	8-22
8.19.2 Using the Return Bus as the Ground Window	8-22
8.19.3 Requirements for Both Kinds of Plants.....	8-22
8.19.4 Requirements for Plants with an Insulated Return Bus.....	8-25
8.19.5 Requirements for Plants with a Noninsulated Return Bus.....	8-25
8.20 Methodology for Establishing an Isolated Ground Plane.....	8-25
8.21 Performance Verification and Test Procedures	8-30
8.21.1 Visual Test.....	8-30
8.21.2 External Power Supplies.....	8-31
8.21.3 Internal Power Supplies.....	8-31
8.21.4 Insulation Test	8-32
8.22 Isolated Ground Plane Noise Circuit Test.....	8-32
8.22.1 Abnormal Current Flow in Grounding Wires and Frames	8-32
8.22.2 Correctly Wired Circuit Arrangements	8-33
8.22.3 Correcting Improperly Wired Circuit Arrangements	8-33
8.22.4 Overvoltage Protectors.....	8-34
8.22.5 Improper Load Connections	8-34
8.23 Distributed DC Power Plants in the Isolated Ground Plane	8-34
9. Grounding Methods	9-1
9.1 Frame Grounding.....	9-1
9.2 Conductor and Connection Requirements.....	9-1
9.2.1 Girdling	9-3
9.3 DC Power System Grounding (for PDCs).....	9-4
9.4 Isolated Power Plant and Integrated Ground Plane Equipment Application.....	9-4
9.5 Ground Window	9-5

CONTENTS (Continued)

Chapter and Section	Page
9.6 Establishing a Separate Ground Window	9-10
9.6.1 Dimensions	9-11
9.6.2 Locations	9-11
9.6.3 Ground Window Connections	9-11
9.7 Separation of Isolated Plane Metal from Integrated Plane Objects	9-11
9.8 Typical Bonds from the Ground Window Bus	9-12
9.9 PANI Concept.....	9-13
10. Outside Plant Equipment Enclosures	10-1
10.1 Controlled Environmental Vaults (CEV's).....	10-1
10.2 Other Controlled Environment OSP Enclosures (huts, CECs, UEs, etc.)	10-8
10.3 Above Ground Outdoor Type Cabinets/Housings.....	10-8
10.4 Grounding of the AC Neutral	10-11
10.5 Customer Premises Electronic Equipment Installation Grounding.....	10-13
10.5.1 Special Electrical Protection for Customer Premises Locations On or Near High Voltage Electric Power	10-15
10.5.2 Customer Premises Computer Room.....	10-15
10.5.3 Customer Premises Isolated Ground Planes	10-16
11. Computer Room Ground Environment	11-1
11.1 Purpose.....	11-1
11.2 Scope	11-1
11.3 Grounding Concepts	11-1
11.4 Optimal Ground Point	11-2
11.5 Signal Reference Grid (SRG)	11-2
11.6 Cabinet Grounding System	11-3
11.7 Other SRG Connections	11-4
11.8 ACEG “Green-Wire Ground”	11-4
11.9 Raised Floor Surface	11-5
12. Definitions.....	12-1
12.1 Acronyms	12-1
12.2 Glossary.....	12-8

CONTENTS (Continued)

Chapter and Section	Page
13. References	13-1
13.1 Industry Standards Documents and Codes	13-1
13.2 Telcordia (formerly Bellcore) and Bell System Documents	13-2
13.3 Government Specifications	13-3
13.4 CenturyLink Technical Publications	13-3
13.5 Ordering Information.....	13-4
13.6 Trademarks	13-6

Tables	Page
1-1 Grounding Terminology Cross-Reference	1-2
3-1 Typical Soil Resistivity Ranges	3-2
5-1 Minimum and Typical Ground Electrode Conductors for DC Plants	5-2
5-2 Minimum Frame Grounds for DC Plants and Distribution	5-2
5-3 Minimum and Typical Grounding Electrode Conductors for Separately-Derived Sources Fed from a DC Battery Plant	5-4
5-4 DC 0.01 Ohm Resistance Distances at Cable Rack Temperatures	5-5
5-5 Chassis Ground Sizes When Required and Not Specified.....	5-7
5-6 Minimum and Typical Grounding Conductors Run for CLEC Cages	5-10
8-1 Tabulation of Typical Ground Window Connections	8-24
9-1 Tabulation of Typical PANI Bar Connections	9-17

Figures	Page
3-1 Nomograph for a Deep-Driven Rod or Well	3-6
3-2 Typical OPGP Connections	3-12
3-3 Various Methods of Establishing Supplemental Ground Fields in Buildings with Basements	3-13
3-4 Typical Routing of a Vertical Equalizer and Placement of CO GRD Buses in a Multifloor Building with a Basement	3-25
3-5 Representation of the Maximum Area to be Served by a Single COGB	3-26
3-6 Typical Horizontal Equalizer System on a Toll Equipment Floor	3-27
3-7 Typical Equipment Connected to a CO GRD System	3-28
3-8 Pipe and Conduit Ground Clamps.....	3-30
3-9 Crimp (Compression) and Pressure-Type Connectors	3-31

CONTENTS (Continued)

Figures (Continued)	Page
4-1 Typical Engine-Alternator that is Not Separately-Derived	4-3
4-2 Atypical Engine-Alternator that is Separately-Derived	4-3
4-3 Transformer with Separately-Derived Source Re-Grounding at the Secondary	4-4
4-4 Transformer with Separately-Derived Source Re-Grounding at the First Disconnect	4-4
4-5 Grounding for Inverter with Maintenance Bypass (Not Separately-Derived) ...	4-5
4-6 Grounding for Inverter without Maintenance Bypass (Separately-Derived)	4-5
4-7 Typical Large UPS with an Input Isolation Transformer	4-6
4-8 Typical AC Service Grounding Electrode Arrangements.....	4-7
4-9 Single ACEG Conductor Serving Multiple AC Circuits in a Common Conduit Run	4-15
4-10 Requirement For Grounding Frames Mounting AC Operated Equipment Units	4-16
4-11 Typical Arrangement of ACEG Conductors at the Service Entrance and Standby Equipment	4-19
4-12 Typical Standby Engine Room Grounding Scheme for an OPGP Office	4-20
4-13 Typical Standby Engine Room Grounding Scheme for a PANI Office.....	4-21
4-14 Typical Above Ground Fuel Tank/Steel Containment Tank and Outside Standby Engine Grounding Scheme	4-22
4-15 Typical Busduct System Equipment Grounding Arrangement for a 3-Phase, 3-Wire System	4-23
4-16 Typical Power Distribution Cabinet Equipment Grounding Arrangement	4-24
5-1 Example of a Possible CLEC Switch Isolated Ground Plane Environment	5-13
5-2 Example of CenturyLink Ground Window Sequencing and Possible Sequencing for a Separate CLEC Ground Window	5-14
6-1 Underground CO Entrance with Exposed Entrance Cable for Traditional Isolated-Integrated Offices	6-5
6-2 Underground CO Entrance Cable Incorporating an Insulating Joint	6-6
6-3 Bonding and Grounding of Optical Fiber Cable in Interconnect Equipment.....	6-7
7-1 Microwave Ring Ground System and Principal Ground Bonds	7-4
7-2 Typical Grounding Arrangement for a Metal Antenna Tower.....	7-5
7-3 Grounding Arrangement for Wooden Antenna Supports	7-6
7-4 Grounding Arrangement for a 3 Pole Wooden Antenna Support	7-7
7-5 Grounding Arrangement for a Single Pole Wooden Antenna Support.....	7-8
7-6 Bonding of Outdoor Waveguide	7-14

CONTENTS (Continued)

Figures (Continued)	Page
7-7 Typical Arrangement of Peripheral and Exterior Ring Bus Bonds at Waveguide Hatchplates for Single Story Structures	7-15
7-8 Typical Arrangement of Peripheral and Exterior Ring Bus Bonds at Waveguide Hatchplates for Multistory Structures.....	7-16
7-9 Method of Bonding to 1/2" - 2" Conduit or Pipe	7-17
7-10 External Ground Bus for a Waveguide Hatchplate	7-18
7-11 Typical Ring Ground Installation in a Microwave Station	7-21
7-12 Wall Support Assembly for an Interior Ring Ground	7-27
7-13 Typical Supplementary Ground Crimp Connections.....	7-28
7-14 Method of Supporting Ring Bus Wire on Cable Rack and Connection of Bond Wire.....	7-29
7-15 Method of Supporting Supplementary or Interior Ground Ring Runs from Channel Framing	7-30
7-16 Typical Grounding of Antenna Tower Guy Wires	7-33
7-17 Grounding of a Typical Wireless Pole Site with a Metal Fence	7-35
7-18 Grounding Interface Between a Typical Wireless Pole Site and a CO.....	7-36
7-19 Grounding of PCS Equipment Mounted to an Existing Roof Tower.....	7-37
7-20 Typical Grounding of Wireless Equipment Mounted on a Building Roof.....	7-38
7-21 Ideal Grounding Interface Between the Ground Electrode Field of a Wireless Site and a CenturyLink CO Ground Ring.....	7-39
7-22 Grounding Interface Between the Ground Electrode Field of a Wireless Site and a CenturyLink CO Using a Deep Driven Rod, Counterpoise, or Chemical Ground (Ground Well) System	7-40
7-23 Grounding Interface Between the Ground Electrode Field of a Wireless Site and a CenturyLink CO that only has the Power Company MGN as a Ground Electrode Field.....	7-41
7-24 Grounding Interface Between a Wireless Site and a CenturyLink CO where CenturyLink is Providing the AC Power from Within their Building.....	7-42
7-25 Wireless Pole Mounted Antenna Grounding Details.....	7-43
7-26 Rooftop GPS Antenna Grounding Detail.....	7-49
8-1 Simplified Isolated Ground Plane	8-3
8-2 Simplified Examples of Serial and Radial Frame Grounding	8-4
8-3 Typical Overall Frame Grounding Methods	8-7
8-4 Loops (Isolated Ground Plane)	8-13
8-5 Typical Grounding and AC Power Feed to an Isolated Ground Plane	8-17
8-6 Typical Sequence of Connections to a Separate Ground Window	8-23

CONTENTS (Continued)

Figures (Continued)	Page
8-7 Typical Grounding and Power Feed from a DC Power Plant Powering Isolated Ground Plane Loads.....	8-26
8-8 Grounding for Integrated and Isolated Ground Planes Powered from a Common Power Plant.....	8-27
8-9 Using an Insulated Return Bus as The Ground Window	8-28
8-10 Using a Noninsulated Return Bus as The Ground Window	8-29
9-1 Maximum Multifloor Ground Plane Spread Using a Single Power Plant	9-6
9-2 Digital Switch Isolated Power Plant Application.....	9-7
9-3 Ground Window Busbar Configurations.....	9-8
9-4 PANI Example.....	9-13
10-1 CEV Sectional View of Excavation and Ground Rod Installation.....	10-3
10-2 Typical CEV Excavation and Driven Ground Rod System	10-4
10-3 Typical CEV Bonding of Upper and Lower Housings.....	10-4
10-4 Typical Grounding Arrangement for CEVs.....	10-5
10-5 Typical Inside Grounding for CEVs.....	10-6
10-6 Examples of Grounding Schemes for Existing CEVs	10-7
10-7 Typical RT Site Where Most Structures are Grounded to a Common Bar	10-10
10-8 RT Site Structures Grounded to Ring When SAI Sheathes Isolated.....	10-10
10-9 Power Pedestal and RT Treated as One Structure.....	10-12
11-1 Typical Computer Room Grounding Arrangement.....	11-6
11-2 Bolted Stringer Raised Floor to Pedestal Connection.....	11-7
11-3 Supplemental Signal Reference Grid	11-8
11-4 Typical Cabinet Grounding Arrangement.....	11-9
11-5 Computer Cabinet Grounding Bar.....	11-10
11-6 Attaching Braided Strap to a Round Raised Floor Support Pedestal.....	11-11

CONTENTS

Chapter and Section	Page
1. Introduction	1-1
1.1 General.....	1-1
1.2 Cross-Reference of Terminology	1-1

Tables

1-1 Grounding Terminology Cross-Reference	1-2
---	-----

1. Introduction

1.1 General

This publication presents CenturyLink's requirements for electrical grounding methods for metallic frames, bays, and cabinets; and the electrical power supplies associated with a variety of Central Office (CO) Equipment (COE), or other telecommunications equipment that is installed within remote electronic equipment enclosures (EEEs), such as Controlled Environmental Vaults (CEVs), huts, Remote Terminal (RT) cabinets, and Customer Premises Equipment (CPE) installations (where the premise equipment is CenturyLink-owned).

General Outside Plant Bonding and Grounding requirements (e.g., for buried and aerial cables, NIDs, etc.) are covered in applicable local and national Codes (such as the National Electrical Code [NEC] and National Electrical Safety Code [NESC]), as well as CenturyLink and Telcordia OSP Practices and Training documents.

Chassis Grounds and other grounds internal to a relay rack or cabinet are covered in Technical Publication 77350, Chapter 11; and in Telcordia Generic Requirements document GR-1089.

1.2 Cross-Reference of Terminology

One of the most confusing parts of telecommunications grounding is the proliferation of terms (especially acronyms) that mean the same thing, but are used differently by various manufacturers, or are different in differing facilities. Because CenturyLink is an amalgamation of many historical companies, the same type of grounding equipment, bar, etc. may be called different things in different buildings depending on the history of ownership. The following Table 1-1 gives a cross-reference of some of the most common terms that may be found in this document or in various telecommunications facilities that mean essentially the same thing.

Table 1-1 Grounding Terminology Cross-Reference

Component	Names	Place(s) Commonly Used
site principal ground point	OPGP MGB PANI bar TMGB MET PGP SPGP	RBOC COs independent telco sites independent telco sites Customer Prems Customer Prems OSP electronics sites OSP electronics sites
floor ground bar	COGB FGB	RBOC COs independent telco COs
Isolated Ground Zone	Isolated plane IGZ IBN SPG	RBOC COs independent telco sites international term computer rooms
Integrated Ground system	Integrated plane Non-IGZ CBN	RBOC sites independent telco sites international term
Logic ground	LRE/G quiet ground signal ground	certain Class 5 switches copper loop testing equipment computer equipment
Ground Window Bus	MGB isolated-integrated bar SPCB	RBOC COs RBOC COs international term
isolated frame grounds bar	FGE/B GWB	certain Class 5 switches independent telco sites
bar for metal < 6' from IGZ	FOG ICB	certain Class 5 switches certain Class 5 switches
Surge Suppressor/ Arrestor	TVSS SPD	older term newer term
AC frame/equipment ground	ACEG green-wire ground bare copper wire PE	NEC term NEC term NEC term international term

CONTENTS

Chapter and Section	Page
2. General Requirements.....	2-1
2.1 Reasons for Proper AC and DC Grounding	2-1
2.1.1 Personnel Safety	2-1
2.1.2 Equipment and Distribution Circuit Protection.....	2-1
2.1.3 Electrostatic Discharges (ESD)	2-1
2.1.4 Reliability	2-1
2.1.5 Equipment Operation.....	2-1
2.1.6 Noise Reduction.....	2-1
2.2 Minimizing Grounding and Bonding Impedance	2-2

2. General Requirements

2.1 Reasons for Proper AC and DC Grounding

For the safety of personnel and the protection of equipment, Central Offices and Remote Terminal locations shall meet the following requirements for both Alternating Current (AC) and Direct Current (DC) grounding environments.

2.1.1 Personnel Safety

All metallic parts within a ground plane and a grounding system shall be grounded such that voltage potentials cannot shock personnel. The grounding and bonding of metallic frames and raceways will minimize potential differences between these structures whenever the building or surroundings is struck by lightning, or whenever an electrical fault produces fault currents.

2.1.2 Equipment and Distribution Circuit Protection

If the grounding and bonding system is of sufficiently low impedance, overcurrent devices such as fuses and circuit breakers may interrupt/disconnect fault currents to prevent electrical fires and limit damage to equipment or circuit conductors.

2.1.3 Electrostatic Discharges (ESD)

The effects of ESD events are minimized by maintaining a bonded environment of low impedance paths between grounded points throughout the ground plane and grounding system. Many metallic parts of the ground plane are capable of storing electrostatic charges. Care must be taken during the installation and maintenance of ESD sensitive devices to ensure that static discharge from other devices and personnel (or even personnel wearing wrist straps) is properly transferred to well-grounded telecommunications equipment frames and chassis'.

2.1.4 Reliability

The grounding system should resist deterioration and require minimal maintenance.

2.1.5 Equipment Operation

The grounding system should protect operating equipment and minimize the effect of disturbances originating outside the ground plane.

2.1.6 Noise Reduction

The grounding system should minimize electrical interference on operating equipment by maintaining a low impedance pathway (bonding) between ground points throughout the telecommunications system. Within isolated ground planes, the grounding shall prevent or minimize the effect of noise currents and Radio Frequency (RF) energy.

2.2 Minimizing Grounding and Bonding Impedance

In a telecommunications environment, the most effective grounding and bonding system is the one with the least amount of impedance. In this document, wire sizes and connection methods are based on trying to provide a low impedance path at a reasonable economic cost.

Impedance (Z) is a combination of electrical resistance (R) to the flow of AC or DC current, and capacitive and inductive reactance (X) for AC behavior (note that reactance changes with the frequency of the AC signal). All of these values (R , X , and Z) are measured in Ohms (Ω). In a purely DC circuit, the resistance is the only factor. However, even in DC circuits, AC behavior can occur. Lightning currents, short circuits, impulses, etc. are all AC wave forms. All wire and connections have Resistance. The smaller the wire, the greater the resistance. The smaller the metallic contact area in a connection (due to the physical size or shape of the connector; paint, oxide, excessive anti-oxidant compound, or other insulators; or a loose connection), the higher the resistance. In a telecommunications bonding and grounding system, inductance and capacitance are not purposefully added to the system; however, all wire also has inductance, which is increased by turns/bends, and parallel conductors and some connections have capacitance.

CONTENTS

Chapter and Section	Page
3. Building Ground Requirements	3-1
3.1 Ground Electrodes	3-1
3.2 Acceptable Methods	3-3
3.2.1 Ground Ring	3-3
3.2.2 Deep Driven Rod.....	3-5
3.2.3 Ground Grid or Array	3-7
3.2.4 Counterpoise.....	3-7
3.2.5 Well Casings	3-7
3.2.6 Deep Well Ground	3-8
3.2.7 Backfilled Wells	3-8
3.2.8 Supplemental Grounding Electrodes.....	3-8
3.3 Materials.....	3-10
3.3.1 Ground Rods.....	3-10
3.3.2 Exterior Ground Wire.....	3-13
3.3.3 Interior Ground Wire	3-15
3.3.4 Connectors	3-17
3.4 Connections	3-19
3.5 Main Site Ground Bus (OPGP, SPGP, or PANI MGB)	3-19
3.6 Identification of Grounding Conductors.....	3-20
3.7 Design Parameters of Vertical Equalizer System	3-21
3.8 Design Parameters of Horizontal Equalizer System.....	3-21
3.9 CO GRD System Raceway Application	3-24
3.10 Grounding and AC Feeds for Separate Buildings.....	3-24

Tables

3-1 Typical Soil Resistivity Ranges	3-2
---	-----

CONTENTS (Continued)

Figures	Page
3-1 Nomograph for a Deep-Driven Rod or Well	3-6
3-2 Typical OPGP Connections	3-12
3-3 Various Methods of Establishing Supplemental Ground Fields in Buildings with Basements	3-13
3-4 Typical Routing of a Vertical Equalizer and Placement of CO GRD Buses in a Multifloor Building with a Basement	3-25
3-5 Representation of the Maximum Area to be Served by a Single COGB	3-26
3-6 Typical Horizontal Equalizer System on a Toll Equipment Floor	3-27
3-7 Typical Equipment Connected to a CO GRD System	3-28
3-8 Pipe and Conduit Ground Clamps.....	3-30
3-9 Crimp (Compression) and Pressure-Type Connectors	3-31

3. Building Ground Requirements

3.1 Ground Electrodes

A ground electrode may be considered as a connector in a conductor path. An efficient connector is one that contributes insignificant impedance to the flow of current in the path. Generally, efficiency is ensured by provision of sufficient surface contact between a connector and the conductive components that it joins. A ground electrode joins metallic grounding electrode conductors to earth.

Note: Generally, the building grounding system is always considered as part of an Integrated Ground System. For additional information on Integrated Ground Systems, see Chapter 5 of this publication.

Earth surrounding an electrode must be considered as a conductor in series with a conductor path to some point in earth remote from the electrode. Earth resistivity is variable, dependent primarily on metallic mineral content, presence of electrolytic salts, acids, granular nature of the soil, and moisture (see Table 3-1). The following factors that can affect the impedance to earth of a grounding electrode include:

- Temperature affects the resistivity. For example, resistivity increases drastically when the soil freezes, and for this reason, rod length below the frost line is all that can be considered effective. Current discharged into ground therefore will create a voltage differential between the electrode and remote earth that will be relative to the earth resistivity and the electrode - earth contact area.
- Over time, current flow may evaporate moisture around electrodes. This causes a condition known as soil potting. For this reason, rods should be located in an area where they can be watered, by natural rain, or artificially by a watering system.
- Grounding electrodes located adjacent to building foundations can affect the zone of influence required for proper electrode soil bonding. Where possible, placement of grounding electrodes shall be equal to a minimum of one half of their length away from any structure or object that may impede the natural zone of influence.

A massive current discharge through a single electrode with modest surface contact with earth can create an extreme voltage differential between earth in the immediate vicinity and remote earth. Generally, this differential can be minimized by an increase in surface contact between electrode and earth, and by assuring that the electrode is in contact with permanently moist earth.

Since earth nearest the surface is more drastically affected by weather, an increase in the length of a vertical electrode will be more effective in decreasing the electrode to earth resistance than an increase in electrode diameter. A long electrode will penetrate further into permanently moist earth (where resistivity will be less). However, note that long single electrodes are not the most preferred grounding electrode in most situations. Ring (also known as buried halo) ground arrangements are usually best due to the multiplicity of interconnected electrode penetration points over a wide area.

Table 3-1 Typical Soil Resistivity Ranges

Soil Composition	Meter-Ohms
Sea water (reference)	1 - 2
Clay with no sand or gravel	3 - 160
Loam (sand, silt, and clay)	5 - 50
Limestone	5 - 10,000
Clay mixed with sand & gravel	10 - 1,350
Sandstone	20 - 2,000
Concrete (use 50 Ω -m for calculations when value unknown)	30 - 300
Chalk or Shale, or sandstone	60 - 800
Sand and gravel mixture	300 - 5,000
Quartzite, Granite rock	500 - 10,000
Slate	600 - 5,000

Before installing a grounding electrode at a CO or radio site, measure soil resistivity (with an earth resistivity tester, using the 4-point method; and preferably averaged at more than one location at the site) to determine the type and size of ground system to use. (There are computer programs to design a ground electrode system from an earth resistivity measurement, and some simpler equations are also given in this chapter.)

After installing the ground system, test it before and after connecting it. Impedance of the system measured with an earth resistance tester (often incorrectly called a Megger™) using a 3-point fall-of-potential method with the middle rod approximately 62% of the distance to the far test rod (proper use of a meg-ohmmeter for measuring earth resistivity and impedance to earth, including that greater spacing between test rods is better, is described in IEEE 81), should be (where economically practical) 5 ohms or less (3 ohms or less is preferred for NNS sites). In areas where the isokeraunic activity exceeds 30 lightning strikes per mi²/yr, 1 ohm or less is the desired resistance to earth.

Use of clamp-on resistance meters has been gaining popularity. CORM usage is described in Telcordia BR 802-010-100; but there is easy potential for misapplication. Because "megger" measurements are generally more accurate, the use of CORMs for measuring resistance to earth of is usually discouraged. If an existing ground electrode system cannot be disconnected to measure resistance to earth with the 3-point fall-of-potential method, a properly used CORM might prove useful. CORMs are especially useful for measuring continuity or isolation (see Sections 3.4, 6.3, and 8.23.4).

If a 5 ohm impedance can't be obtained, contact a CenturyLink Electrical Protection Engineer for assistance. For (OSP) locations (e.g., CEVs, huts, cabinets, etc.) exceptions can be made to the requirements to measure soil resistivity and obtain 5 ohm resistance. Although 3-point fall-of-potential tests and 5 ohm resistance are desired, requirements for OSP locations are in Chapter 10 of this document (the resistance of the ground electrode system shall not exceed the 25 ohms of NEC Article 250.53A2 Exception).

Office ground electrodes commonly employed in CenturyLink installations are (1) the power utility's MGN (the connection between this and the site SPGP is known as the Bonding Conductor for Telecommunications, or BCT), (2) cold water metal pipes, (3) building steel, or (4) made grounding electrodes such as ground rings, etc. All of the aforementioned that exist shall be bonded together at the SPGP. The NEC (250.104B) requires that gas piping be bonded only if it is likely to become energized, since we don't want to introduce electric ground current onto a potentially explosive system.

3.2 Acceptable Methods

The acceptable methods for establishing a site Ground Electrode (MGE) are listed below, in order of preference.

3.2.1 Ground Ring

Driven rods, which individually represent rather modest contact with earth, are used in multiple and bonded together with wire to create a common electrode. They are arranged in a pattern at or around the site to equalize earth potential in the area of the site. The primary conductor of a ground ring system often circles the building and is extended into the site by at least two conductors. These conductors should connect at opposite sides of the ring and terminate at the OPGPB (PANI MGB) or interior ring/halo ground conductor. (Routing of these connections to the OPGP should cross as little interior building space as possible – if one of the routes is near the switch, it is better not to have the diversity.) Rods shall be spaced 10-20 feet apart around the ring (greater spacing [up to double the rod length] should be used for longer/stacked rods). For the size of driven rods, see paragraph 3.3. The advantage of a ring, as opposed to a straight line, is not greatly decreased resistance to earth, but increased reliability in case the ring is cut in one location.

- The minimum length of ground rod(s) used in a driven ground, ring ground, or a supplemental ground system is 8 feet (2.44m). This minimum length is specified to ensure penetration to permanently moist earth.
- The depth of rod penetration is important. The rod should penetrate below the frost line and to a depth of permanent ground moisture for a most effective ground (it is preferable to get the entire rod below frost line if possible; including the ring conductor). The electrode shall be installed at least 30 inches below grade and at an approximate distance of 1/2 the rod length from the exterior wall (for RT cabinets, the electrodes need to be installed a minimum of 2 inches outside the perimeter of the concrete pad).
- Where rock bottom is encountered, the electrode may be driven at an oblique angle not to exceed 45 degrees from the vertical or buried in a trench that is at least 2-1/2 feet (762mm) deep. The upper end of the electrode shall be flush with or below ground level unless the above ground end and the grounding electrode conductor attachment are protected against physical damage (see NEC 250.64B and 250.70).

- At larger buildings (such as COs and radio sites), where future access to the ground ring may be necessary for additional external connections, future rings shall be installed with bottomless handholes for at least 2 of the rods (on differing sides of the building). Leads in the handholes should be tagged.
- The exterior ring shall be connected to the top of the rods by an exothermic weld connection or an approved compression connection designed for solid wire.
- Metallic objects within 6 feet of a ground ring should be bonded to it in order to minimize step/touch potential during a lightning strike.

If soil resistivity (in meter-ohms) is obtained by a 4-point measurement, ground field resistance to earth can be estimated in order to design a system to meet the max ohm requirement. The following equation gives the approximate value of resistance to earth when four 8' x 5/8" diameter rods are placed 16' apart in a ring/rectangle configuration buried 30" below grade (see Section 10.3 for more into on this config).

$$R_{e-4r} \approx \frac{\rho}{20}$$

where:

ρ = average soil resistivity. Such values are obtained from a 4-terminal earth resistivity test (whose measurements typically have to be converted to ohm-meters by multiplying the test reading by 2ℓ , where ℓ is the distance in feet between any two of the four equidistant test rods, which are driven to a depth of 1/20th of the spacing, where the optimum spacing equals total depth [including cover] of the expected rod[s] to be used).

The next equation approximates the resistance to earth when three 8' x 5/8" diameter rods are placed 16' apart in a triangle configuration 30" below grade (this type of configuration is described in section 10.3, and shown in Figures 7-4 and 10-6).

$$R_{e-3t} \approx \frac{\rho}{15}$$

The next set of equations are much more complicated, but give the approximate resistance to earth when there are more than four 8' x 5/8" diameter rods placed 16 feet apart in a ring/square/rectangle configuration buried 30" below grade.

$$R_r \approx \frac{\rho}{n} \left(0.465 + 0.0655 \left(\ln \frac{2n}{\pi} \right) \right)$$

where:

\ln = the natural logarithm (base "e" [exp])

R_r = the estimated resistance to earth of the rods alone

n = the number of 8' long by 5/8" diameter rods

$$R_w = \frac{\rho}{15.33n} (\ln(351n))$$

where:

R_w = the estimated resistance to earth of the 2 AWG solid wire buried 30 inches below grade

$$R_m = \frac{\rho}{15.33n} (\ln(6.95n))$$

where:

R_m = the mutual resistance from interaction between the 30" deep buried 2 AWG wire and the 5/8" diameter by 8' ground rods

$$R_T = \frac{R_w R_r - R_m^2}{R_w + R_r}$$

where:

R_T = the total resistance of the ring

The calculated resistances in the formulas of these sections are at a frequency much lower than lightning. Due to soil ionization around the rods, wires, etc. at lightning frequency, the actual impedance may be twice as high as the calculated resistance. It may be wise to shoot for a resistance value of half the desired end result (e.g., if the user desires an impedance to earth of 5 ohms, design for a resistance of 2.5 ohms).

3.2.2 Deep Driven Rod

A minimum 5/8" (preferably 3/4") rod (stainless steel shouldn't be used in excessively alkaline soils – use copper-clad steel rods instead) shall be driven down to a minimum of 40 feet and a reading of 5 ohms or less obtained (the 5 ohms pertains to CO type sites – see Chapter 10 for requirements for OSP types of sites). After 5 ohms is obtained, drive the rod 10 feet more if possible. Install a composite box around the top of the rod strong enough to withstand heavy loads. Connect the rod to the SPGP with a 2 AWG solid copper conductor. All connections to the rod must be treated with a copper-coat or other corrosion prevention product. Make sure that all connections are pointed downward, with a min. 8" bending radius.

Figure 3-1 is a nomograph for determining the length of a deep driven rod if soil resistivity has been measured. Computer programs exist that will do the same thing as the nomograph. These same programs will also calculate the number of rods needed for a ground ring. The input to all these programs is a soil resistivity, obtained with an earth resistivity tester. Section 3.2.6 gives an equation for calculating the expected resistance to earth of a deep-driven (or any length) single rod, pipe or well, and section 3.3.1 gives simplified equations for multiple rods in a straight line (section 3.2.1 gives simplified equations for ground rings).

Generally, the effectiveness of a deep-driven rod or well is not linearly increasingly effective with length (as the nomograph shows), unless the soil resistivity continues to decrease as you go down (high resistivity soils on top and better ones below and/or a deep water table). This is why four vertical 8-10' rods spaced 16-20' apart typically provide a lower resistance to earth than a single 40' rod (unless the water table is found between 11 and 40 feet of depth). However, a deep driven rod can be useful when multiple rods cannot be placed due to site considerations, or the water table will be contacted by the deep-driven rod when the traditional depth rods will not contact it.

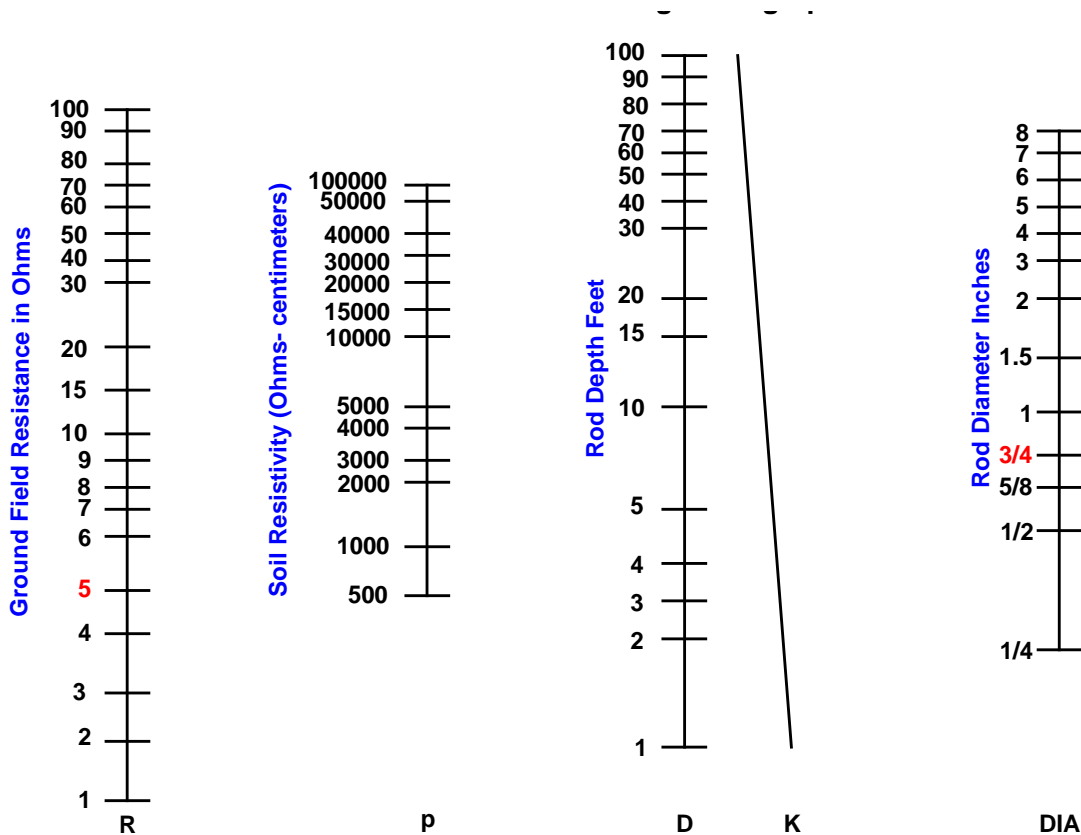

1. Select required resistance on "R" scale (2=Recommended and 5=Maximum)
2. Select measured or apparent resistivity on scale "P".
3. Lay a straightedge on "R" and "P" scale and intersect with "K" scale.
4. Lay straightedge on "K" scale intersect point and "DIA" scale 3/4 Inch and intersect "D" scale.
5. Point on "D" scan will be rod depth required for resistance on "R" scale.

Figure 3-1: Nomograph for a Deep-Driven Rod or Well

3.2.3 Ground Grid or Array

A ground grid or ground rod array consists of a number of ground rods, between 10 feet and 20 feet apart. They are driven in a symmetrical pattern and interconnected with wire to form a grid or other such pattern such that each individual rod in the pattern is connected to at least two other individual rods in the pattern. The size of the grid may vary with the size of the facility protected. Ground grids are generally used to reduce step potentials (with even closer spacing than what is mentioned above) at electric generating stations, substations, and high voltage transmission towers. They offer little additional benefit to traditional ground rings for CenturyLink telecommunications sites, but may still be used where they exist. The array is installed at least 30 inches below grade, and two conductors from opposing corners or sides are extended into the Central Office and connected to the OPGPB. If no OPGPB (or PANI MGB) exists, one shall be established.

3.2.4 Counterpoise

Bedrock near the surface may prevent driving rods, or adverse soil conditions may limit the effectiveness of a conventional ground ring or grid system. A counterpoise ground electrode system may be necessary with, or in place of, the conventional rod electrode system. A counterpoise system may be less effective than a driven rod system in producing a low-impedance ground system. It serves primarily as a metallic path for the effective dissipation of lightning current. It is essential that as large an area around the building as practical be used as a field for the dissipation of current. A counterpoise system consists of a buried wire ringing the building, with rods if they can be driven (even if at an oblique angle), and buried uninsulated conductors extended from the four building corners in a straight line away from the building for no less than 25 feet. The ring and conductors are buried 30 inches below grade. The counterpoise system is sometimes called a radial system.

3.2.5 Well Casings

Well casings, which generally penetrate earth to a considerable depth, constitute an excellent electrode with massive current dissipating ability. It may be economical to install a well casing/pipe as a grounding electrode system rather than (or in addition to) a driven ground system. This may apply especially in areas where gravel or other earth conditions make effective grounding by means of driven rods impractical, or where a driven rod installation will cause considerable expense. While the National Electric Code (Article 250.52A1) requires that the buried portion of the system be not less than 10 feet (3.05m), for CenturyLink applications, the buried piping should be electrically continuous for at least 40 feet (12.2m). The well may be located on the property outside the building or beneath the building.

The well need not be functional as a water supply to serve as an earth electrode. Generally, a driven supplemental ground field will be more economical than a well supplied for grounding purpose only, unless special cost considerations are a factor.

3.2.6 Deep Well Ground

A steel well casing may be driven vertically into the earth at a point not less than 10' from the building foundation and capped not less than two and one half feet below grade level. The downleaders should be exothermically welded to the metal cap to maintain electrical continuity. The following formula may be used to calculate well size and resistance to earth (the same formula applies to a single deep-driven rod):

$$R_{e1} = \frac{\rho \left(\ln \frac{35L_r}{d} \right)}{2L_r}$$

where:

R_{e1} = the estimated ground resistance of a single rod (traditional length or deep-driven) or ground well casing.

L_r = the length of the rod or well casing in feet. A minimum of 20 feet must be used for any single well casing. The maximum casing length is limited to 250 feet.

d = the diameter of the well casing or rod in inches. A 2 inch minimum is required for well casings.

3.2.7 Backfilled Wells

In rocky areas, it may be nearly impossible to find naturally occurring soils nearby that are good enough to obtain a decent ground. In these cases the only alternative may be a backfilled well.

The backfilled well typically consists of a rod(s), or a hollow section of metallic pipe (which may or may not have a rod inside of it), inserted in a drilled hole(s). This is then backfilled with water-absorptive bentonite clay, calcine petroleum coke, or low grade (conductive) concrete. Then the system is initially "watered".

Wells (or rods) backfilled with chemicals other than the more natural bentonite, coke, or concrete are prohibited in CenturyLink for environmental reasons.

3.2.8 Supplemental Grounding Electrodes

Many below-ground structures are used as supplemental grounding electrodes (supplemental means that at least one of the methods described in Sections 3.2.1 to 3.2.7 must be used as a primary grounding electrode, and supplemental electrodes must be tied to the primary electrodes). Some are listed in the rest of this subsection:

Public Water Systems - Public water pipes, though buried below frost lines, may not be a reliable grounding electrode due to the use of insulating couplings and nonmetallic pipes. If metallic water pipes in contact with the earth for more than 10' are available, they may be used as a supplemental electrode per NEC 250.52A1.

Per NEC 250.66, 250.166, and 250.168, the size of the conductor (and meter jumper) shall be at least #6 AWG (minimum resistance to the OPGP [PANI MGB] of 0.01 Ohms) and sized based on the largest HSP entrance conductor (in PANI offices, this connection is generally made with a 2/0 cable). It is best to connect to the water pipe within 5' of its entrance (see NEC 800.100B2). Interior metal water pipe must be bonded to the ground system per NEC Article 250.104(A), regardless of whether it serves as a supplemental electrode; and if the water utility doesn't permit connection of grounding electrode conductors to their public system, ensure a plastic section of piping separates the interior from the exterior water system.

Building Steel – If no other bond exists to building rebar (see the paragraph later in this section on Ufer grounds) or to structural steel (as shown in Figure 3-3), a solid bond shall be made from the SPGP to the nearest appearance of building structural steel. The connection shall be no smaller than #2 AWG (in PANI offices, 2/0 AWG is preferred, with a cable resistance of less than 0.01 Ohms).

Central Offices with Basements - Figure 3-3 illustrates the following recommended methods of establishing a supplemental ground field for buildings with basements:

- Electrical continuity via structural steel columns, or welded/strapped rebar.
- Since there are a large variety of construction methods, a supplemental ground field must be designed to fit the unique requirements of the building.
 - Figure 3-3, Plan "A" consists of ground rods at every column foot.
 - Figure 3-3, Plan "B" illustrates a typical configuration recommended for buildings that do not have vertical column continuity. The ground field conductors are run within 2' of the column footing but are not bonded to it. Minimum requirement for ground rods, at columns on the peripheral conductor ring, is shown. Additional rods near interior columns may be employed by the designer. The ground field conductors, bonded either to steel columns or run near footings of reinforced concrete columns, provide a low impedance path for currents seeking earth through the columns. These bare conductors effectively disperse the current over a wide area to driven rods on the periphery of the building where permanently moist earth is more likely. Bare wire contact with earth adds to the surface afforded by rods, to reduce resistance to earth. The wire, which bonds the driven rods into a common electrode, also acts as an equalizer to minimize difference of potential in the earth under the building. The ground field shall be connected to the building OPGP with at least two conductors from opposite sides of the field. These connections afford paths to the ground electrode for currents imposed on the equipment grounding system in the building and provide earth reference to the communication and electrical power systems. Generally, Plan "A" will provide a good ground electrode, but Plan "B", or any other similar plan may be used.

Buildings without Basements – Buildings without basements are assumed to be of medium or small size switching systems. For these buildings, an exterior driven ground system shall be employed as the primary ground electrode. The conductors entering the building shall terminate at the OPGPB.

Existing Building Additions – A building addition abutted to an existing building may be provided with a separate water supply. This second water supply must be bonded to the OPGPB.

- When a common communication installation is housed in two closely adjacent buildings (i.e., separated by an alleyway) having individual grounds, the principal ground points shall be bonded together using a 750 kcmil conductor.
- Structural steel ground grids are provided in some types of building construction. They shall be bonded to the OPGPB with a No. 2 AWG wire.

When it is suspected that operation of equipment is affected by a poor grounding system, earth resistivity measurements are recommended. A review of the ground electrode system should be done. Where it is proven that the resistance to ground is excessive, it may be possible to reduce it by adding additional rods, a counterpoise system, or by connecting the casing of a drilled well to the electrode system. Contact the CenturyLink Electrical Protection Engineer for assistance.

Other Ufer Grounds – Any concrete-encased metallic electrode (including rebar) can serve as a supplemental ground. These types of grounds are named after their principal investigator, Herb Ufer. The most common types include floor slabs on grade, including basements (already discussed in this section), tower footings, and buried concrete vaults without insulating coatings. Any of these can serve as a supplemental ground as long as an attachment can be made to the rebar. In fact, for all new buildings (and building additions), the NEC requires that the rebar of the building foundation be bonded to the other grounding electrode(s). This can be done by bonding the rebar to an external ground electrode field (COGF) or to the SPGP. Ufer grounds are only more effective than direct-buried conductors when the resistivity of the concrete is lower than the surrounding soil (see Table 3-1).

3.3 Materials

3.3.1 Ground Rods

Stainless steel rods or copper-clad steel rods (with a minimum cladding thickness of 13 mils and an average cladding thickness of at least 15 mils) are allowable. They shall be at least $\frac{5}{8}$ inch (15.87 mm) in diameter for lengths of 8' or more. Stainless steel rods shall be of ANSI grade 32 or 34 alloy, which are resistant to corrosion. Copper is significantly more electropositive (cathodic) than iron or steel. Copper exposed to earth moisture near buried metal objects such as water pipes, fuel tanks, etc., can cause accelerated corrosion of iron or steel through electrolytic action.

Stainless steel is not significantly electropositive to iron or steel; therefore, it does not create the corrosive effect of copper (but is susceptible to corrosion in salty/alkaline soils; and thus shouldn't be used in those types of soils). However, stainless steel is more resistive than copper by a couple of orders of magnitude. Because stainless steel rods are very costly, they only make economic sense at our more important CO, CDO, fiber backbone and Radio sites. However, the hundreds of thousands of OSP applications we have (CEVs, huts, RT cabinets, cable sheaths, homes, etc.) preclude the general use of these expensive rods. For OSP applications, copper-clad steel rods are the norm. Bare or galvanized steel rods, steel covered with stainless tubing, or hollow core pipes of any type shall not be used as ground rods. Nonferrous rods or their equivalent shall be Listed and shall not be less than 1/2 inch (12.7 mm) diameter (1/2" diameter rods are common when 5' rods are used in the OSP environment). Generally, solid copper rods are too soft to be utilized (will bend too much if driven in most soils).

The resistance to earth of ground rods driven in a straight line (as described for some site situations in section 10.3) can be estimated prior to installation if the earth resistivity (from a 4-pole test) in meter-ohms is known. For a simple 2-rod system (5/8" diameter x 8' rods), where the distance between the rods is 16', and the connection is made with bare 2 AWG solid wire buried at approximately 30 inches, the equation is (note that the values produced by all of the equations below are approximate, since no soil is homogeneous, and rounding and assumptions were made to simplify the calculations):

$$R_{e2-L} \approx \frac{\rho}{10}$$

For a 3 -rod (5/8" diameter x 8' rods) system in a straight line, where the rod separation is 16', and the connection is made with bare 2 AWG solid wire buried at 30 inches, the approximate resistance to earth of the system is

$$R_{e3-L} \approx \frac{\rho}{15}$$

For a 4 -rod (5/8" diameter x 8' rods) system in a straight line, where the rod separation is 16', and the connection is made with bare 2 AWG solid wire buried at 30 inches, the approximate resistance to earth of the system is

$$R_{e4-L} \approx \frac{\rho}{19}$$

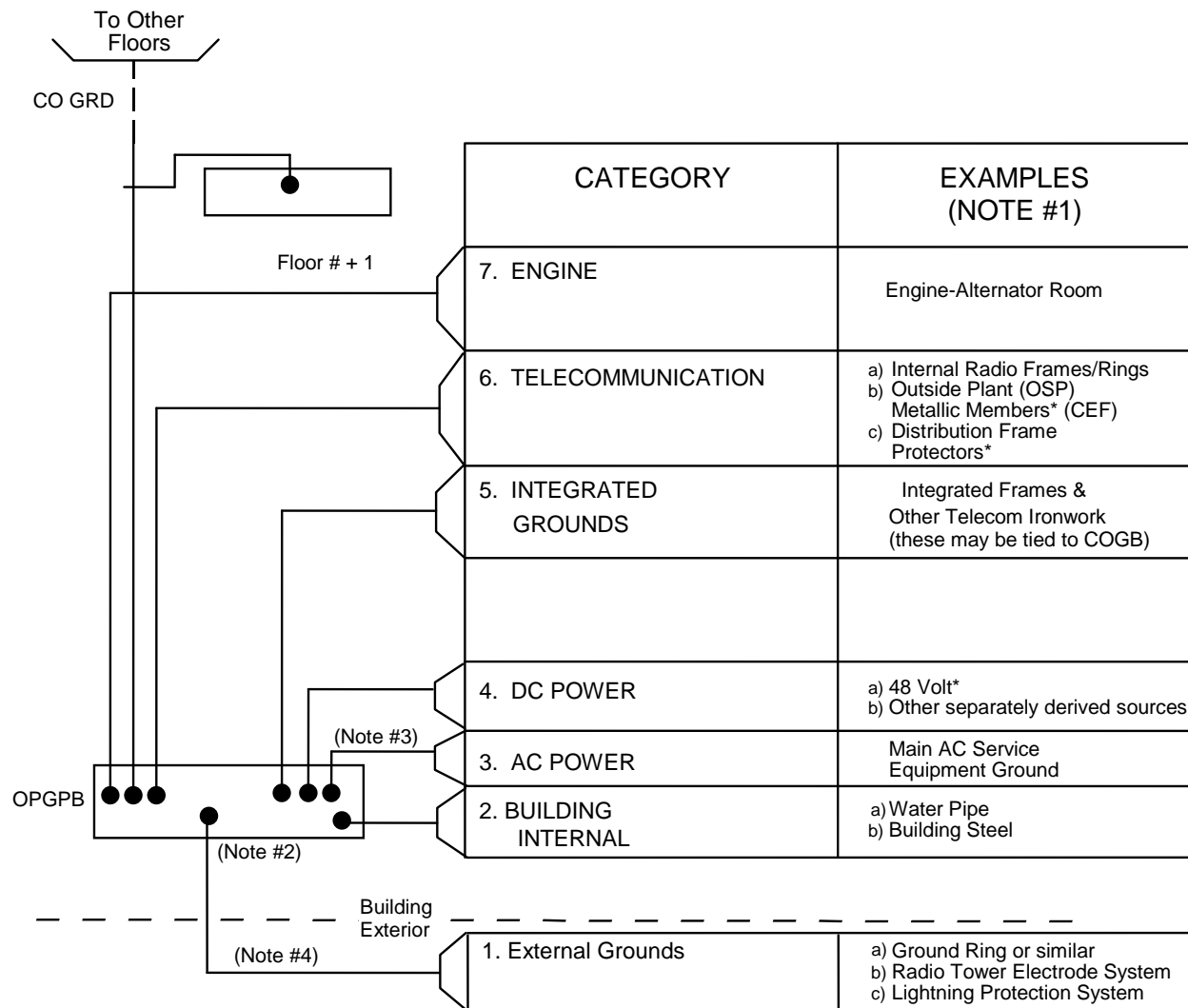

Notes:

1. Items marked with an asterisk may have ground bars associated with them.
2. The floor with the OPGP may also have a COGB depending on the area covered, and the number of holes needed.
3. AC neutral grounding electrode reference conductor size is determined by NEC.
4. These may be tied directly to the OPGPB, or a COGB, whichever is closer.
5. Where possible, the connections from internal building points will generally connect on the side on the bar opposite the connections from the grounding electrode points (no 180 degree bends should be used in any case).

Figure 3-2: -Typical OPGP Connections

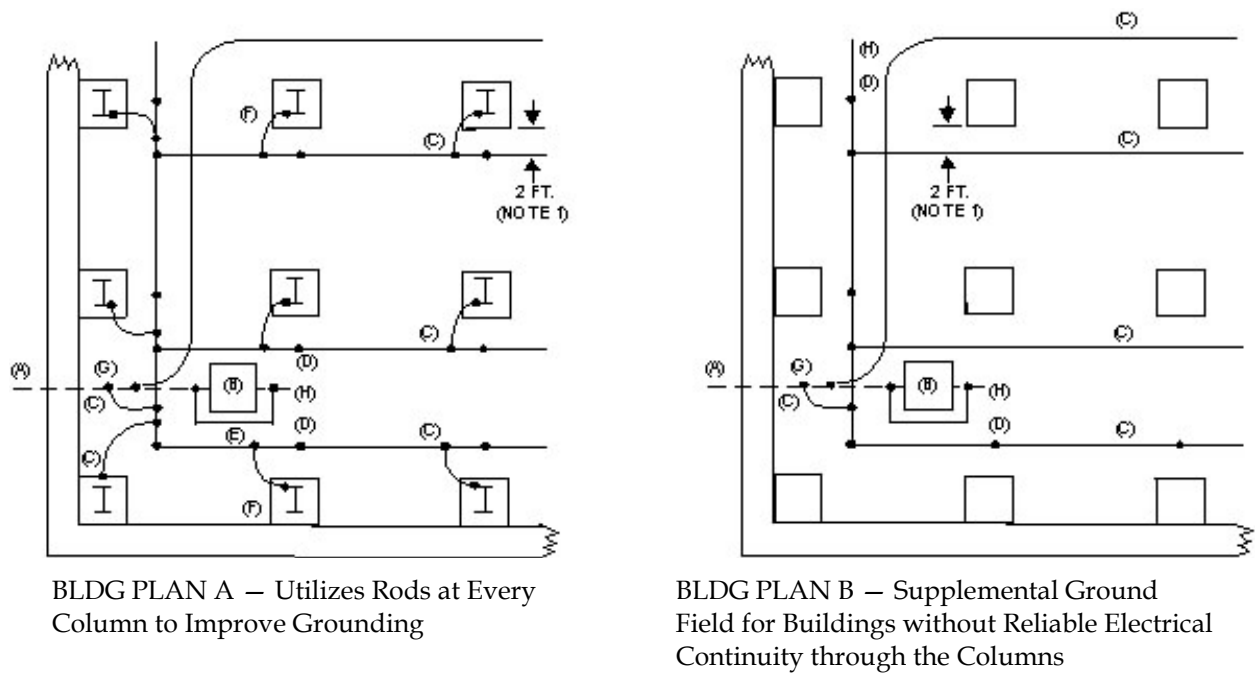

LEGEND

- (A) Water Pipe
- (B) Water Meter
- (C) No. 2 AWG Bare Tinned Copper Wire
- (D) 5/8" Stainless Steel Rod; 8 ft. (or 10') long
- (E) Denotes an Exothermic Weld of a No. 2 to a No. 2 AWG Wire
- (F) Denotes an Exothermic Weld of a No. 2 AWG Wire to Column Steel
- (G) Denotes an Exothermic Weld of a No. 2 AWG to Water Pipe or the OPGP
- (H) Denotes an Exothermic Weld of a No. 2 AWG Wire to the Top of Rod (D)

NOTES

- (1) Maintain a 2 ft separation between the grounding electrode wires and the columns for bending radius purposes

Figure 3-3: Various Methods of Establishing Supplemental Ground Fields in Buildings with Basements

3.3.2 Exterior Ground Wire

Ground electrode systems employing driven rods or wire counterpoise are constructed by use of a No. 2 AWG solid tinned copper (untinned copper is allowed in certain OSP applications) conductor buried in the earth. The wire should have smooth bends with a minimum bending radius of 8" (12" bend radii or more are preferred if possible). As the wire is subject to corrosion, tinned copper wire is used exclusively at COs, CDOs, fiber huts, and Radio sites because it corrodes at a slower rate than any other economically acceptable wire.

The requirements for minimum wire size and type listed below are based on the relative significance of a number of factors: adequate conductivity, maximum longevity of the ground system, minimum galvanic effect on other buried objects, and physical resistance to damage. Other factors, such as the need to dissipate excessive RF energy in certain areas, may necessitate that larger wires are used. Types of wire for buried applications are:

- **Required – Minimum No. 2 AWG Bare Solid Tinned Copper Conductor**
For general applications, this wire provides adequate conductivity, maximum longevity, minimum galvanic effect, and adequate strength. Wire shall be soft (annealed) or semi-hard drawn commercial grade.

Tinned solid copper wire is generally not stocked commercially and often cannot be purchased from commercial sources in specific quantity suitable for individual installations. It may be purchased through the purchasing arm of CenturyLink, and may be made available to our contractors.

Pigtail leads are to connect individual rods to the No. 2 wire only if exothermic welds or compression connections approved for the application are employed to connect the pigtail to the top of the ground rod, and to the ring.

Note: If the high strength copper compression ground rod method is used, drive the rod to the desired depth. Prerimp the ground rod before making the high compression ground rod tap connection. The reason for the prerimp is to increase rotational resistance by using the appropriate prerimp die. Do not pound the ground rod after the compression connection has been applied.

- **Restricted – Bare Solid Untinned Copper**
Lack of tinning will increase the galvanic effect on buried steel or iron objects. Although bare solid tinned copper is required for exterior ground wire use in COs, CDOs, fiber backbone huts, and Radio sites, its limited availability and high cost make it somewhat impractical as a requirement for the hundreds of thousands of OSP applications (e.g., CEVs, RT cabinets, etc.) Although bare solid tinned copper is preferred, bare solid untinned copper is allowed in the OSP.
- **Prohibited – Insulated Conductors for general Bonding of Driven Grounds**
Insulated conductors may be used only for connection of cathodic protection systems utilizing sacrificial anode rods and a DC current supply to render buried objects cathodic. They may also be used for connections between the OPGPB and the driven ground system. However, they are not to be used to connect the conductors together. The use of insulated conductors reduces efficiency of a driven ground system without adding equivalent benefits.

- **Prohibited – Buried Bare Stranded Copper Wire, Tinned or Untinned**
This wire, generally acceptable for industrial systems' ground electrodes, is prohibited because of reduced life expectancy and increased galvanic effect. The life expectancy of the individual small strands exposed to corrosive conditions is significantly less than that of a single solid large diameter wire, and the galvanic effect on buried steel or iron is greater. However, stranded tinned copper conductors shall be permitted as part of roof lightning protection systems.
- **Prohibited – Aluminum Grounding Wire** of all types shall not be used.

3.3.3 Interior Ground Wire

Wire employed in the equipment grounding system (which comprises the CO GRD system and extensions therefrom to frameworks, cabinets and other units requiring equipment grounding) shall be RHW type insulated commercial grade stranded copper wire (alternatively XHHW type copper conductor may be used, or TFFN wire may be used on wire sizes smaller than 14 AWG but must be protected at every tie point and point of impingement). Aluminum conductors shall not be used in the equipment grounding system. Note that there are two types of RHW insulation in use. One is a soft rubber, that must be "fibered" at points of impingement, or have a cotton braid outer covering. The other is a non-halogenated, thermoset, hard plastic, very similar to XHHW insulation. This newer RHW wire, when used for grounding is green with yellow markings. Green insulation is required going forward for interior ground wire unless it is "manufacturer wiring" for pre-wired bays, shelves, etc. THHN or THWN wire may be used for grounding in non-metallic conduits and in engine or AC electrical switchgear applications.

Interior grounding conductors of 1/0 AWG and larger size, whether run on walls, ceilings, cable rack hangers, or the sides of cable rack; and whether run horizontally or vertically, must be supported at least every 18 inches (passing between floors or walls, supports can be as far as 5 feet apart). For ACEG conductors run in conduit, per the NEC, the conduit itself must be supported at least every 10 feet, and within 3 feet of every outlet, junction box, pull box, etc.

Types of wire for interior applications are:

- **Preferred – Stranded RHW (or XHHW) type Green-Insulated Copper Wire**
(In accordance with the NEC, wires other than “grounding” conductors shall not be green. For example, the “grounded” -48 VDC battery return conductor[s] insulation shall be gray or black. The “green” requirement for DC grounding conductors is applicable as of Jan. 1, 1999, and applies to 6 AWG and larger conductors. It is recommended [but not required] for smaller wires, including chassis grounds.) Crimp connectors shall be used with this wire. The insulation affords protection of the wire from paint and corrosion, and eliminates strand separation at bends and incidental contacts of indeterminate impedance with metallic structures. It requires more frequent support than solid wire and requires stripping of insulation at bond points. Generally, RHW and XHHW wire is not made in sizes smaller than 14 AWG, so if smaller sizes are used due to manufacturer recommendation, they may be green-insulated TFFN if protected at all tie points and points of impingement. (Note that internal shelf grounding and shelf-to-rack/bay "chassis" grounding as well as engine and AC switchgear applications and wire run in non-metallic conduit may use THHN or THWN type wire. The green insulation applies to both frame grounding wires and reference/equalizing grounds/bonds. Because switch manufacturer's requirements inside isolated ground plane switch footprints supersede our requirements, they are not absolutely required to use green insulation.)
- **Alternate – Stranded Bare Copper Wire**
This wire shall be connected with crimp connectors (unless it is a flat braid). It is easy to install and is commercially available. Special care must be employed to avoid separation of the strands at bends. Separation doesn't reduce the wire's protection, but has a poor appearance. Stranded wire requires more frequent support than solid wire. Bare stranded wire supported from walls shall not be painted. Stranded bare copper wire is a grandfathered practice. Green-colored insulated wire should be used going forward for interior grounding wire outside the cable vault.
- **Alternate – Solid tinned or untinned bare copper wire**
This wire can only be connected with an appropriate crimping tool and die designed for the size wire and connector; or by an exothermic weld with the proper die, lug, etc. (An exception is made for solid flat ribbon conductor since there are no compression crimps designed for this type of wire.) Both solid and stranded braid flat conductors are limited to use in the cable entrance facility. Pressure type connectors are less reliable. The wire is somewhat more self-supporting than stranded wire, but difficult to install and straighten. It is not always available from commercial sources.

- **Prohibited – Peripheral Ground Rings Composed of lengths of Rigid Conductive Material**

This would include UNISTRUT® channels, or steel pipe, bonded with straps or other conductive material around corners or other points of channel discontinuity. Experience with this form of peripheral ring indicates that it is less reliable than a wire system. Dependence on continuity through numerous bolted joints increases the probability of high impedance in, or discontinuity of, the ring. Visual verification of ground continuity is often impossible. The cost is greater than that of a ring system using stranded wire and crimp connectors. It is recommended that existing systems of this type be replaced.

- **Prohibited – Aluminum Wire** of all types is prohibited going forward.

3.3.4 Connectors

Thermal Welding – Thermal welded connections are an approved method for connections buried in earth, or for termination of copper conductors to copper, steel, or iron objects. Thermal welding includes both exothermic welds and brazing. After a thermal weld is made, it is advisable (especially for outdoor applications) to apply an anti-corrosion product to seal the weld, and prevent the start of corrosion at the weld point.

- **Exothermic Weld** – The exothermic type welding process utilizes graphite molds to form welds. A crucible in the top of the mold holds a metallic powder which, when ignited, produces molten copper that flows by gravity into the form surrounding the joining point. The hot copper melts the material of the items being welded, forming a molecular bond. Each configuration of weld requires a unique graphite mold; and, because of limitations imposed by the gravitational flow requirement and heat generated by the process, there is some restriction of application. There are mold types designed with a cover and filter system (which eliminates smoke and sparks) for indoor use (a welding/cutting permit is still required). There are "one-shot" molds and reusable molds. The reusable molds must be cleaned and dried between each use, and cannot be used for more than 50 "shots". Exothermic welds should never be pounded (to drive them further into the ground or to test them – tapping them to test them is okay).

- **Brazing** – Brazing may be used in place of exothermic welds in outdoor or cabinet installations. Brazing provides the same benefits derived from an exothermic weld. It requires the use of an external heat source (brazing torch) and brazing rod to provide the material for a molecular weld between parts to be joined. An exothermic weld is superior in some respects. Exothermic weld creates a uniform weld shape, and it produces heat so quickly that the weld is completed before dissipation of heat affects conductor insulation. It can also be used in areas where brazing might be prohibited because of nearby combustible material. Brazing is prohibited indoors.

Crimp – Crimp type connectors are required to maintain low resistance conductivity between wire and connectors. Crimp type bolted connectors shall preferably be used for terminating stranded wire ground conductors to frames, cabinets, and other units requiring a bolted ground connection (bolts, nuts, washers, etc. used for crimp lugs shall be stainless steel, copper-plated steel, zinc-plated steel, brass or bronze, or silicon-bronze, and when the mating surface and/or nut/bolt metals differ, it is even more imperative that a thin coating of anti-oxidant grease between dissimilar metals is used). When exothermic weld connections are not employed, commercial crimp connectors may be employed, in accordance with restrictions outlined in the preceding paragraphs (see Crimp [Compression] Type Connectors illustrated in Figure 3-9). When crimps are made to solid wire or rods, hand crimps are not allowed (except for rare cases where the tool and die are Listed for that purpose). These crimps must be made with a hydraulic or electrical crimping tool. Crimp connectors shall be made of copper or tin-plated copper. Seal outdoor irreversible crimps with a conductive anti-oxidant or asphaltum.

- Two hole bolted tongue connectors are required for terminating lugs (except for manufacturer internal frame wiring and/or shelf chassis grounds, and grounding wires smaller than 14 AWG). One/single hole connectors are not acceptable except for the exceptions noted in the previous parenthetical. The contact area of metal to which the connectors are bolted shall be prepared to a bare bright finish and coated with an anti-oxidant compound before joining. When bolted tongue connectors are used outdoors, they should not have a skive (inspection hole), and they should be hermetically sealed (with shrink-wrap in a manner that provides a hermetic seal, or another method).

Clamp Type Pipe Connectors – Ground clamps may be utilized for termination of ground conductors at water pipes (if applicable), conduits, and fence posts (bonds to fence strands and support rails may also use mechanical clamps). Such clamps require periodic maintenance to ensure that a low impedance connection exists. For this reason, principally, they are deemed inferior to exothermic weld connections. There are a variety of designs available from prominent electrical connector manufacturers, which are adequate for such connections. Two clamps or a clamp designed for a two-hole connector are required when using a two-hole crimp connector. The clamps illustrated in Figure 3-7 are recommended for applications where pipe clamps are required.

Wedge Type Connectors – Impact driven wedge-activated compression connections may only be used in lieu of crimp type connection, when physical conditions warrant.

Solder Type Connectors – In conformance with NEC Article 250.8B, connections which depend solely on solder shall not be used for ground connections.

3.4 Connections

All connections of the No. 2 AWG wire to ground rods, building steel, or to other No. 2 branch or bond runs shall be exothermic weld or an approved compression connection designed for the application to ensure a permanent low impedance connection. All connections buried or exposed to elements should be protected with an anti-corrosion product.

Note: If the high strength copper compression ground rod method is used, drive the rod to the desired depth. Pre-crimp the ground rod before making the high compression ground rod tap connection. The reason for the pre-crimp is to increase rotational resistance by using the appropriate pre-crimp die. Do not pound the ground rod after the compression connection has been applied.

Continuity of connections (bonding) and conductors can be measured with a CORM (see Telcordia BR 802-010-100 or the CORM manufacturer's documentation for methods), a standard ohmmeter (less than 0.1 ohms for mechanical connections), or a continuity beeper with a standard DMM.

3.5 Main Site Ground Bus (OPGP, SPGP or PANI MGB)

- Establish an Office Principal Ground Point Bus on a standard bus bar located near the AC Service Entrance Switchgear (preferably on the inside of a building exterior wall, since this will limit lightning exposure of the equipment in the building). In PANI offices, this bus must be isolated from concrete or building steel.

- Bond the OPGPB (or Site Principal Ground Point Bus, or Master Ground Bar) to the Ground Electrode and to any supplemental electrodes which exist, as described in parts of 3.1, 3.2 and 3.3 of this document.
- Bond the OPGPB to the neutral bus of the AC Service Entrance Switchgear using a conductor sized per the NEC 250.66.
- The OPGPB becomes the source for the Office Vertical Equalizer system as described in part 3.7 of this document.
- In single-floor, single-room sites, the OPGPB should generally double as the COGB. If the OPGPB becomes too small to support all of the necessary connections, it can be extended to a COGB in accordance with the guidelines spelled out in Section 3.8.
- Multiple OPGPs may exist in a building that has been expanded. This is allowed if an external connection of the ground electrode field for the added portion of the building back to the original ground electrode field was not possible, or if there is more than one AC entrance. In these cases, the OPGPs must be tied together with a 750 kcmil cable internal to the building, or by a #2 AWG solid, tinned copper conductor external to the building. Label them as OPGP 1, 2, etc.
- Grounding electrode connections (external ground fields, the connection to the HSP MGN, water pipe grounds, connections between separate OPGPs, etc.) to the OPGP (or MGB in PANI offices) should be routed as far away as possible from Network equipment areas (preferably outside the building, or against external walls of the building). If they are in a Network equipment area, it is preferable that they be routed at least 6 feet away from any Network equipment frames. They must be kept at least 2'6" away from any Network equipment,
- The OPGP bar should generally be large enough to accept all of the connections shown in Figure 3-6, along with extra holes for future growth, dependent on office location and expectations. Generally a 1/4" thick by 4" high bar (of necessary length), with dual-hole lug holes of 3/8" dia., spaced on 1" centers, is acceptable. The bar should be set at least 3" off the wall or column. Drilling of existing bars is not generally recommended without the permission of the Design Engineer. Proper protection of nearby equipment and maintenance window guidelines must be followed if done,

3.6 Identification of Grounding Conductors

"DO NOT DISCONNECT" tags shall be provided at both ends on all grounding system conductors at water pipes, ground windows, power plant(s) or OPGPs when the connector is a lug or other disconnectible device. A tag identifying use and/or far end termination shall also be attached to grounding system conductors at the various points of attachment to grounding system components or equipment within the structure.

3.7 Design Parameters of Vertical Equalizer System

A Telecommunications Bonding Backbone (TBB), more commonly called a vertical equalizer/riser [VGR]) is required in multifloor buildings to bond the floor COGBs/FGBs together and to provide earth potential reference to the CO GRD system. The vertical riser functions as a current path for ground current interchange between discharge ground circuits on various floors during periods of load imbalance, as a low impedance path to battery for fault current, and, through its low impedance connection to earth, effectively extends close to earth potential to each of the COGBs. Any floor COGB may be considered as an appearance of the grounding electrode, and any equipment requiring connection to a grounding electrode for proper operation and/or protection shall be connected to the COGB on the same floor as the equipment.

Figure 3-3 illustrates typical routing and connections of a CO GRD system vertical equalizer. A vertical riser must consist of a continuous length of 750 kcmil conductor. The vertical run shall be as straight as practicable, preferably with only minor bends to avoid obstructions such as floor beams. Sharp bends are prohibited. A minimum bending radius of 8 inches is required for all grounding wires (12" is preferred for indoor wires). Splicing of the vertical equalizer by any means other than smokeless exothermic weld or compression type in-line splice connections are prohibited.

The vertical equalizer shall be located so that the horizontal portion of the run to the office principal point bus is as short as practical.

In some large structures, multiple vertical ground risers may be necessary (see Section 3.8). To avoid differences in potential between proximate equipment frames, bond vertical CO GRD risers together at every third floor to limit the difference of potential between the bond points (this horizontal equalizer bond is known as a Ground Equalizer, or GE). Horizontal 750 kcmil bonds (every third floor) between vertical CO GRD risers may be provided to serve as the conductive medium for nominal ground current return of older equipment that does not have the frame ground and return separated (such as D4 channel banks, SLC-96™, and DISC*S®).

3.8 Design Parameters of Horizontal Equalizer System

A CO Ground bus (see 5.7 for design parameters) is required on every equipment floor of buildings utilizing the CO GRD system. The bus shall be located on a column or wall or other accessible location that best serves the requirements of the physical design of the building. The location of the busbars shall be such that:

- The maximum conductive run length between a bus and the furthest grounded equipment unit shall not exceed 200 feet and shall not extend beyond the perimeter of a square superimposed on a circle of 100 feet radius from the bus location. This restriction is based on the hypothesis that a single bus located in the exact center of a 200 X 200 foot building may serve all equipment located on the same floor (see Figure 3-5).

- Figure 3-5 illustrates the maximum area that may normally be served by one CO GRD bus. It is recognized that physical design of buildings may exceed the parameters outlined above, in which case two or more CO ground bars per floor served by separate vertical equalizers individually terminated at the office principal ground point may be required. Specific design requirements are covered herein under paragraph 3.7, "Design Parameters of Vertical Equalizer System".
- Sometimes, a COGB/FGB bar is too small to accommodate all the connections required by equipment growth. Generally, bonding main and individual aisle stringers (stringers are smaller grounding conductors running down the aisle) to horizontal equalizers (which are essentially, an extension of the COGB) can alleviate this overcrowding. In large buildings, as noted in Section 3.7, there may also be another COGB (from a separate vertical riser) on the floor, which can be used (as long as connections meet the distance limitations of the first bullet above). However, if additional COGB connection space is needed, the COGB can be extended with another bar. Preferably this bar should be located within 20 feet (it will usually be much closer) of the original COGB. However, it can realistically be placed anywhere within the 100 foot radius mentioned above. Any cable connected to this "COGB extension" must still meet the distance requirements noted in the first bullet above, with the distance measured back to the original COGB. The "COGB extension bar" shall be connected to the original COGB (or to the vertical equalizer) with a 750 kcmil cable.
- The ideal location for the placement of buses on equipment floors is approximately in the center of the equipment, which should result in approximately equal run lengths of horizontal equalizers and conductors extended therefrom.
- The bond between the vertical equalizer and the CO GRD bus, which provides a conductive path for interchange of current between floors, shall be as short as practicable, so as to minimize impedance in the path. Preferably, the length shall be less than 20 feet.
- All runs of CO GRD equalizer conductors shall be routed so that loops (U shaped configurations) are avoided to minimize the length of such runs. All ground connections of the horizontal equalization system shall be made with exothermic or crimp type connectors. All cable to cable or cable to busbar connections should be made with cables arranged to flow fault currents in the direction of the OPGPB or ground source (this is much more important for cables than it is for busbars – while flow towards the ground source should be attempted with busbars, in some cases, physical limitations may impede doing this).

- As indicated in Figures 3-5 and 3-6, horizontal equalizers that terminate at discharge ground buses of older Battery Distributing Fuse Boards (BDFB) or on horizontal ground equalizers of Toll system discharge circuit conductors shall normally be extended into at least each quarter section of the building. These conductors shall bond BDFB return buses and ground equalizers to afford a path for the interchange of current as the increase and decrease of current flow occurs independently in each discharge circuit.

Note that BDFB equalizers may also serve as horizontal equalizers, and that more than one BDFB can use the same equalizer. This is illustrated in Figure 3-6. Note that BDFBs placed in new areas that will serve only equipment that has the return isolated from the frame ground [DC-I] (equipment with a the return bonded to the frame is known as DC-C, and includes D-4® channel banks, SLC®-96 and SLC® Series 5, and DISC*S®) are not required to have their return bus connected to a COGB (through a horizontal equalizer). If these BDFBs (that don't have their return bus connected to the CO GRD system) are fed from a DC plant with a remote ground window, they should not have their feed return conductors run by the ground window and bonded to it (as has been normally done in the past). No new equipment should have shared return and frame grounding (i.e., all new equipment should be DC-I instead of DC-C).

- A reasonably direct equalization path should be established between discharge ground points because large equalizer current flow is expected whenever two or more power plant circuits feeding BDFB or other toll equipment equalizers terminate on the same floor and the load is heavy on one or more and light on others. Wherever horizontal equalizers run within reasonable proximity to other such runs, they shall be bonded together so as to form a direct conductive path, supplementing the circuitous path afforded by connection of CO GRD equalizers to the COGB. Such bonds are illustrated in the lower right quadrant of Figure 3-6. This is indicated by the BDFB and the "duct bay" equalizer run closely together. They should be bonded together (with at least a #6 AWG). No formula for application of such bonding can be provided. As a rule of thumb, it may be said that conductors in proximity are eligible for bonding if:
 - Points of proximity occur further than 35 conductor feet from the COGB.
 - Total conductor length via the COGB between proximate points is $> 70'$.
 - Direct bond between points of proximity will result in a path between discharge ground conductors of less than one-half the length of the "equalizer stringer" (see cable [B] in Figure 3-6 for an example).
 - Examination of a job grounding schematic drawing after horizontal equalizers and main aisle ground equalizers are located thereon may reveal other conditions where supplementary bonds will reduce the length of ground current paths between discharge ground conductor terminations significantly.

3.9 CO GRD System Raceway Application

The use of raceways for support of equipment grounding conductors other than those associated with the AC equipment ground system is generally prohibited except for sleeves through floors and walls (see NEC Article 300.11), and for short pieces used as guards against damage, or where no other form of support is practical. When raceways are so employed, they shall be of insulating material, such as PVC plastic conduit or fiber duct (see NEC Article 352). The equipment grounding conductors should always be run and supported so that as much of the runs as practicable may be visually inspected.

The only exception to the use of nonmetallic raceways shall be for installations where local electrical codes specifically prohibit the use of raceways of insulating material. Short runs of metallic raceway, principally rigid conduit (RMC), may then be used. These sleeves, guards, or short supporting runs must be short-circuited at each end by means of a No. 6 AWG cable bond between each end of the sleeve and the ground conductor(s) run therein. Connectors at conduit ends shall be clamp type "pipe" connectors; and at the conductor shall be crimp parallel cable connectors.

The bonding of metallic raceway to the enclosed ground conductor is important. A ring of magnetic material around a ground conductor creates an inductive impedance in the ground conductor during periods of fluctuating current flow. In addition to raceway, any magnetic material that forms a complete ring, such as U bolt supports, etc. should generally be avoided. Bonding of such rings to the ground conductor therein effectively short-circuits the ring to eliminate the inductive impedance and in addition provides equipment grounding for the metal enclosure. In the past, many such installations were inadvertently left unbonded. Therefore, use of plastic or other nonmetallic sleeves is recommended to ensure a reliable equipment grounding system. (See also Section 8.13.4 for further information on what types of "girdling" is allowable.)

In some cases, AC raceways (including conduit) may seem like a convenient support structure for DC grounding wires. However, NEC Article 300.11 prohibits this practice. Per CenturyLink Technical Publication 77350 (Installation), DC grounding conductors can be secured to cable racks, hangers, or other suitable framework, but not on AC conduit or raceways. Refer to that publication (and specific section) for more detail.

3.10 Grounding and AC Feeds for Separate Buildings

In some cases, multiple buildings (including temporary or permanent trailers housing working Network equipment) may be found on a CenturyLink property. Whether or not they should have their own ground electrode systems and whether they should be tied together is mainly dependent on three factors: size of the building in relation to the main building, its distance from the main building, and whether the buildings have their own AC Service Entrances.

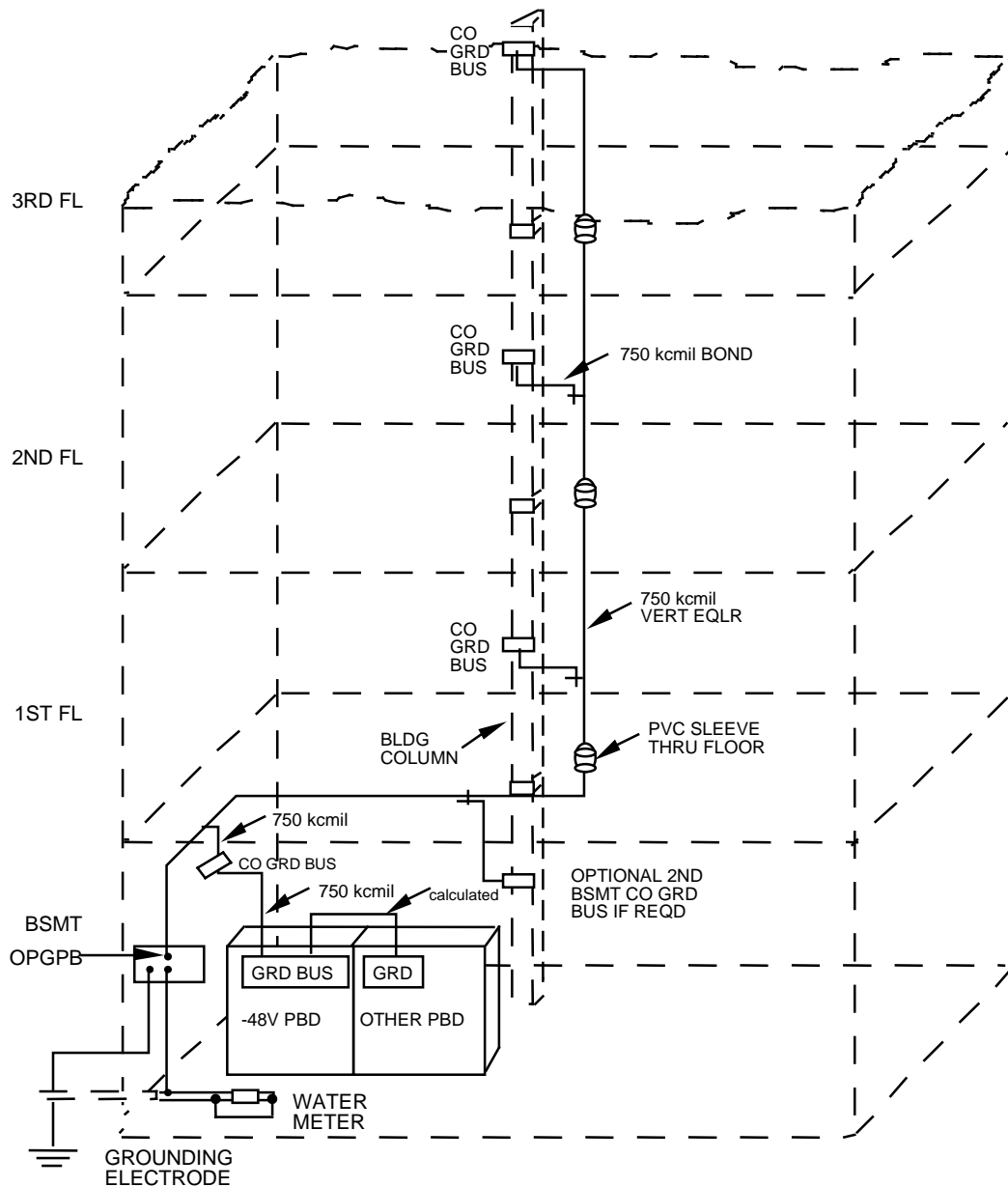

Figure 3-4: Typical Routing of a Vertical Equalizer and Placement of CO GRD Buses in a Multifloor Building with a Basement

Radio site buildings/towers/antennas are a wholly separate matter. They serve as unique lightning attachment points. Grounding guidelines for radio site buildings, towers, and antennas are found in Chapter 7 of this standard. The following guidelines are not as stringent as those for radio towers, but they do borrow heavily from those guidelines and Figures.

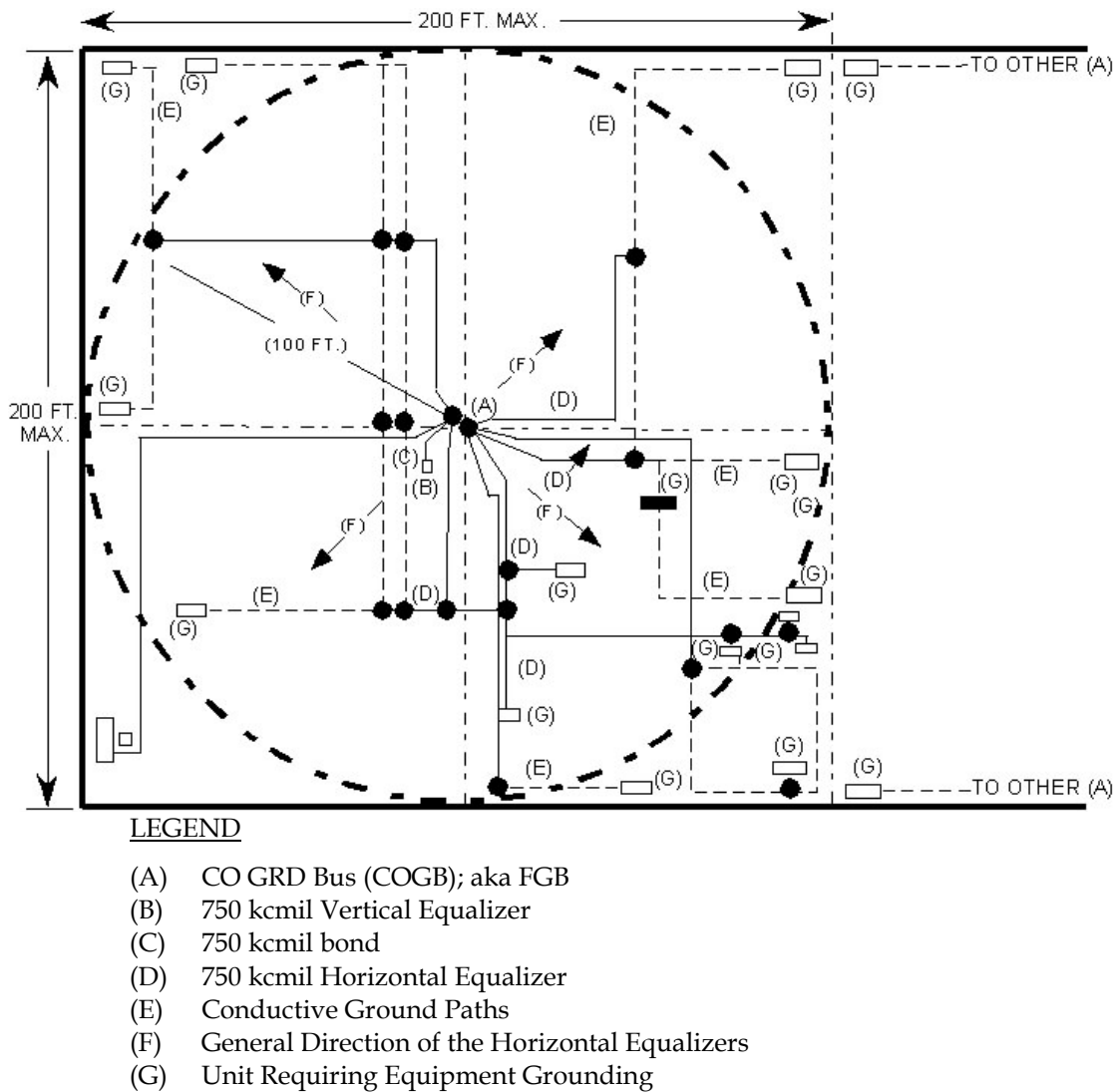
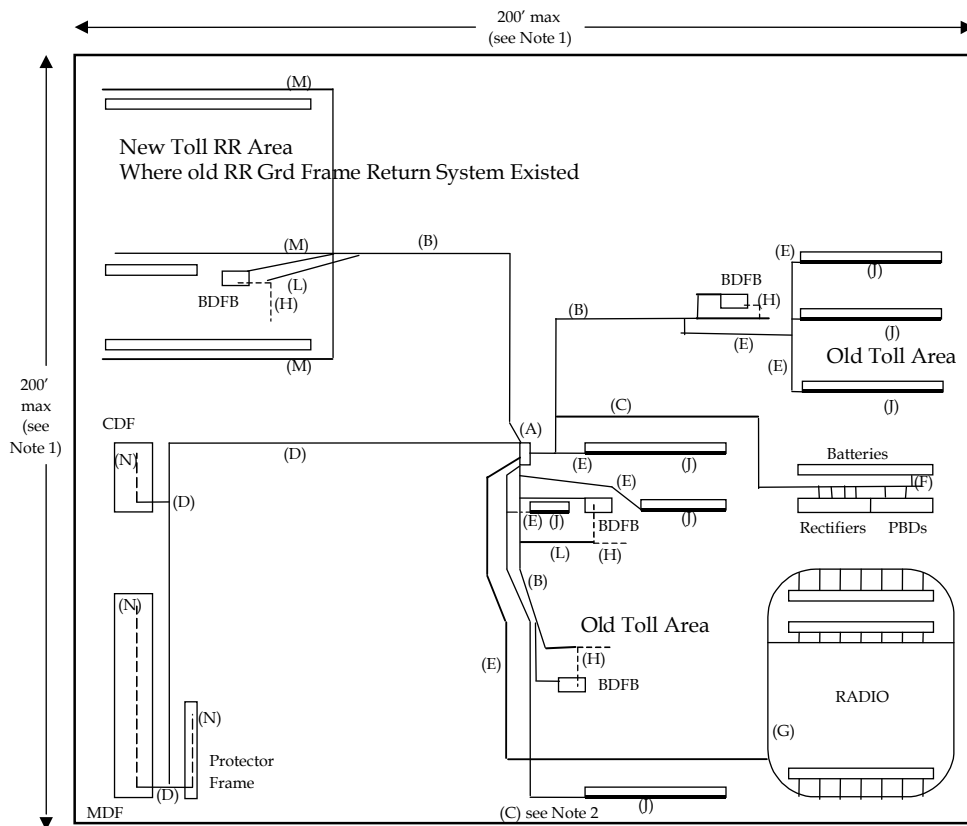

Figure 3-5: Representation of the Maximum Area to be Served by a Single COGB

Per NEC Article 250.32, separate buildings supplied from a common AC service must have each building tied to at least one acceptable grounding electrode field (as described previously in this chapter). If the grounding electrode field is a “ring” (or the grounding electrode field is within 100 feet of the supplementary building), and the “separate” and/or “new” building is within 6 feet of the original building, the new building ground system should be tied to the ground electrode field of the main/existing building in accordance with the aforementioned NEC Article. When the grounding electrode field of the existing building is not nearby, it is permissible to establish a new ground electrode field. When the new and/or supplemental structure is within 6 feet of the original building, the ground electrode fields must be tied together (see Figure 7-1 for an example of how this is done).



LEGEND

- | | |
|---|---|
| (A) Floor CO GRD Bus (COGB) | (H) Return Conductor |
| (B) 750 kcmil CO GRD Equalizer | (J) Duct Bay e/w 1" Pipe (can't use for new bays) |
| (C) 350 kcmil CO GRD Equalizer | (K) 750 kcmil combo Discharge/Frwk GRD Main Aisle Equalizer |
| (D) 1/0 AWG CO GRD Equalizer to Frames | (L) 750 kcmil BDFB Ground Bond to RTN bus (always accompanied with D frame GRD) |
| (E) #2 AWG CO GRD Equalizer | (M) 350 kcmil RR GRD Bond (older arrangement) |
| (F) #6 AWG minimum Frwk GRD Bond (for PBDs/Rects sizing see Sec. 5.4.1) | (N) Distribution or Protector Frame GRD Bus |
| (G) #2 AWG Radio Ring Ground | |

NOTES

- (1) Max. run length to the furthest point shall not exceed 200' from the COGB. The area served by a COGB shall not exceed that bounded by a square superimposed on a 100' radius circle around the COGB. The Vertical Riser and Horizontal Equalizers shall be run as directly as possible.
- (2) Horizontal Equalizers (other than those used for grounding of radio ring or protectors) may be used as multipurpose CO GRD conductors (e.g., the equalizer for toll Relay Racks may be tapped to extend CO GRD to frameworks or cabinets or distributing frames in the vicinity).

Figure 3-6: Typical Horizontal Equalizer System on a Toll Equipment Floor

When the supplementary building is made of metal, the metal of the building shall also be bonded to the ground electrode field.

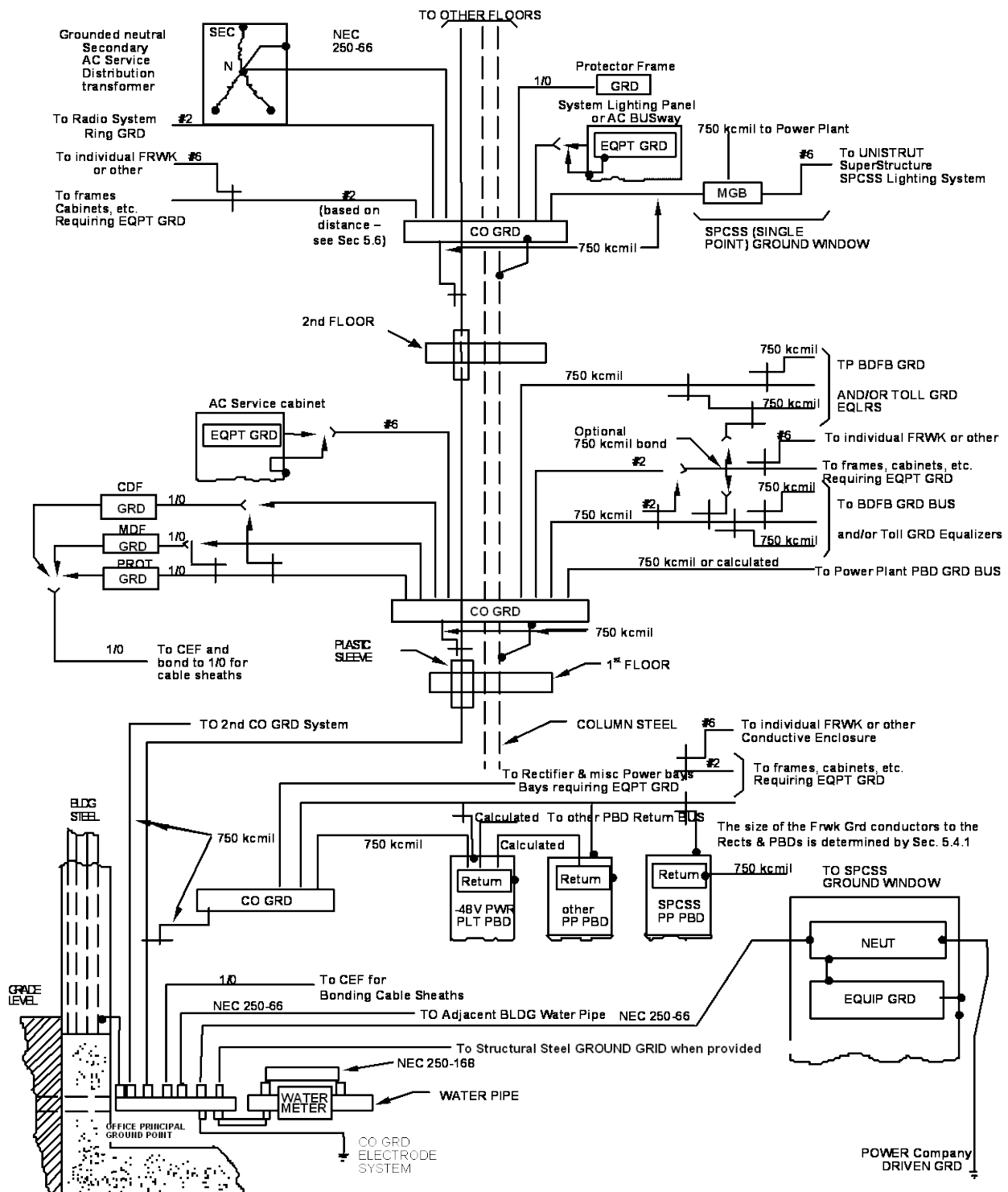
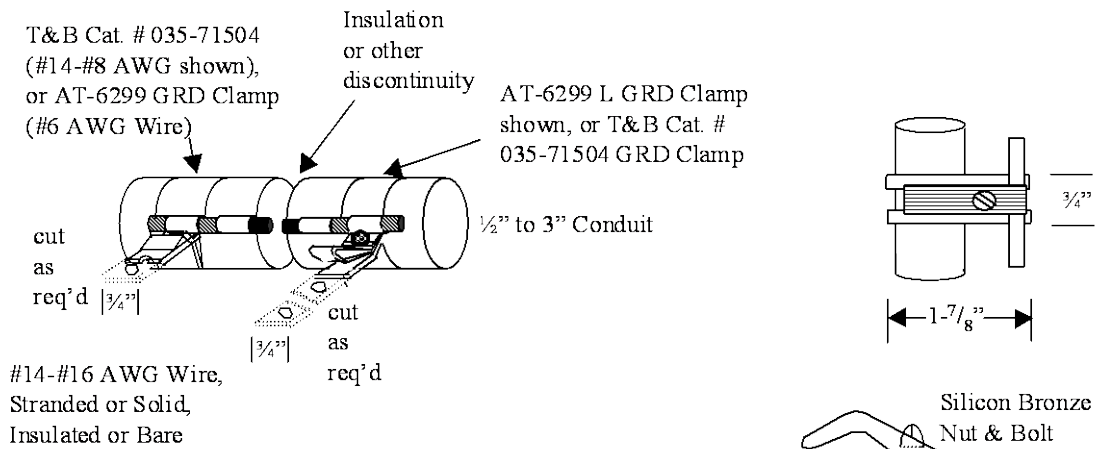

Figure 3-7: Typical Equipment Connected to a CO GRD System

The AC feeder from the main building to the separate building or structure (including standby engine outdoor enclosure structures) must comply with the grounding requirements of NEC Articles 225.30 through 225.34, and 250.32. (Although exceptions in the Code sometimes allow for this AC feed to not have a disconnect at the “new” building, CenturyLink requires it. There must be a disconnect at the original "main" CO building – mounted on the exterior wall or just inside the CO) It is highly preferable that the AC feeder in this case be run in metallic conduit (whether buried, or above-ground).

Whenever a supplementary building or cabinet is fed from the same AC service as the primary building, and the supplementary building/cabinet is not completely under the “lightning” zone of protection (as defined for different geometries by NFPA 780) of the main building, the potential is there for the AC feed to conduct lightning back into the primary building. In these cases (most of them), installation of Transient Voltage Surge Suppression (TVSS), as well as the routing of the AC feed through the building becomes important. These same principles apply to outdoor engines.

For a shared AC power distribution system (reference Figure 7-24 – although it references Wireless equipment, treat the Wireless equipment as if it were a separate building) TVSS devices need to be installed within 5 feet (typically at the Service Disconnect) of where the AC source enters the supplementary building. Both transverse and common mode TVSS should be provided. Even with TVSS at this point, if the feed from primary building to the supplementary building transverses a distance of 50 feet or more outside of the zone of influence, it may be advisable to install additional TVSS at the point the AC service leaves the primary building (and bond this TVSS to the ground electrode field of the primary building). Because the most important Network equipment is DC-powered, it is never allowable to run -48 VDC out from a CO to feed an external building/enclosure (even when the outside structure is under the "zone of influence", and even if TVSS devices were to be installed on the DC feeds). (In the OSP world, feeding nearby RT cabinets from another RT cabinet is allowed because of the short distances and fewer number of circuits affected by the smaller power plant.)



SK-A Conduit Bonding Clamps

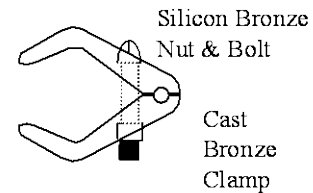

SK-B

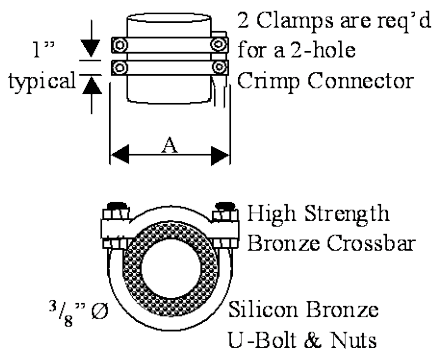

SK-C Ground Pipe Connector for 2-Hole Compression Lug

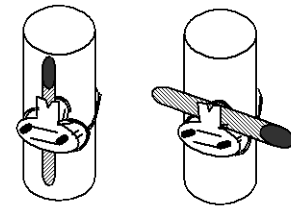

SK-D

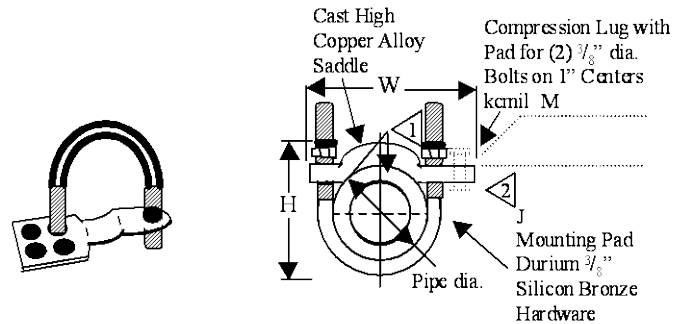

SK-E

Figure 3-8: Pipe and Conduit Ground Clamps

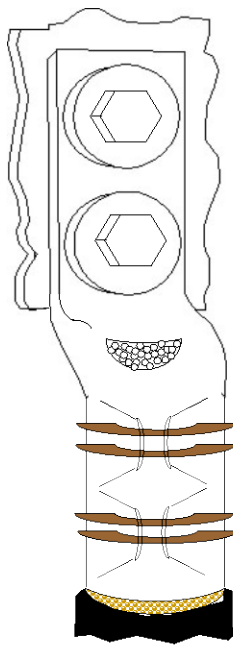

2-hole bolted tongue
crimp (compression)
type connector
("color-keyed", typical)

SKETCH A

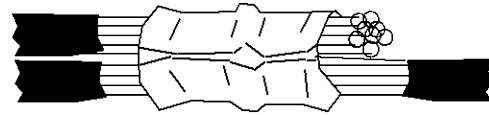

crimp (compression)
type parallel connector
("C"-tap, typical)
for use with #2 AWG
and small stranded wire

SKETCH B

Figure 3-9: Crimp (Compression) and Pressure-Type Connectors

Cable routing through the office is also a concern. If lightning enters the building on the AC feed going to a supplementary structure, we don't want it to have convenient points to jump off into sensitive equipment. If possible, The AC feed (and any ground conductors) leaving the building should take the path out of the building from the AC Service Entrance that passes the least amount of equipment, even if this means more of the AC is run outside the building than inside. Figures 7-17 and 7-23 are poor examples. It would've been better to bring the AC service directly from the HSP or other nearby AC panel (towards the upper right of Figure 7-24). Leave the building at that point, and then run the rest of the AC service outside. It is realized that this is not always possible, but should be done whenever possible. If AC routing through the office cannot be avoided, attempt to run it away from sensitive electronic equipment, especially SPCSS switches (raceway passing within 6 feet of an isolated ground plane must be foreign object grounded, specific to the switch manufacturer's requirements – see Chapter 8 for further information). If the AC service is being obtained from a sub-panel (as illustrated in Figure 7-24), try to choose a sub-panel whose feeder conduit (from the main House Service Panel) passes the least sensitive areas.

For separate buildings on the same property served by separate AC entrances, the requirements are not as stringent. A supplementary building with a separate AC service entrance may have its own ground electrode field, or may choose to use the ground electrode field(s) of the main building (this will usually be determined by distance). The only time that a supplementary building with a separate AC entrance must use the ground electrode field of the primary building, or have its ground electrode field bonded to that of the primary building, is when the secondary structure is within 6 feet of the primary structure, and does not fall completely under its zone of protection. In the rare cases where a supplementary building/structure falls completely under the zone of protection of the primary structure, and the supplementary building does not contain sensitive electronic equipment (i.e., it is used for personnel space or storage), its ground electrode field does not need to meet the stringent requirements of this Section 3 (it may be held to the less-stringent requirements of the NEC Article 250).

The existing grounding electrode system for the CenturyLink CO can be any of several types discussed earlier in this chapter. All are acceptable, although ground rings are preferred. When there are separate ground electrode fields, but points of interface (such as a shared AC service entrance/feed, or a T1 cabling interface, etc.) between the structures, the possibility exists that lightning hitting one structure may not choose the nearest ground electrode field. It may choose to take a path through the other building to get to the “best” ground electrode field. This poses a particular problem when the supplementary building, the OPGPB, the cable entrance and/or the AC service entrance are not located near to each other. Figure 7-21 represents the ideal situation (everything important to grounding is near each other). When this situation isn’t possible, the guidelines of this section and the other documents previously mentioned must be followed to avoid potential problems. In some cases, the Electrical Protection Engineer may specify upgrades to the Building Ground Electrode System in order to rectify potential interface problems.

Any cabling interfaces between separate structures must be protected. Data lines that use copper members (such as T1) must have electrical transient protection at the interconnect points between the structures. For copper facilities interconnecting a CO with an external building, there are basically 4 points of protection: outside the building, at the entrance to the supplementary structure, in the cable vault, and at the CO frame. Typically, all but the cable vault protection involves TVSS solid state “5-pin” protectors. Protectors integral to equipment (not 5-pin) are usually of the “gas tube” type.

Once again, these protection requirements for cabling interfaces are dependent on whether the supplemental structure is completely within the zone of protection of the primary structure (typically it is not).

Figure 7-18 illustrates that protectors must be installed on copper data circuits at a point before they enter the building. Even more preferable is for the protectors to be installed in an external manhole (typically known as MH-0, as shown in Figures 7-21 and 7-22), and bonded to that manhole's bonding ribbon. The bonding ribbon of manholes is Ufer grounded to the rebar of the vault, and out through the concrete of the vault to all the soil in contact with that vault. If the protectors are installed in an external protection pedestal (above ground), it must be grounded to a ground electrode field. If it is close enough to the CO ground electrode field, it may be connected to it. Or, the "protection pedestal" may have its own ground electrode field, preferably made with three rods, similar to configurations shown in Figures 10-7 or 10-8, or Figure 7-22. If at all possible, this ground electrode field should be connected to another external grounding electrode field that is tied to the OPGP.

Just as with any other cable with copper members, cables entering the Cable Entrance Facility (CEF) or Vault must be shield grounded as specified in Section 6 (see also Figures 7-20 and 7-21).

After leaving the CEF, the copper facilities will have a point of presence on the MDF, DSX, or Cosmic Frame. At this point they will also be protected with a "5-pin" protector.

Oftentimes, outside cabling enters through conduit. Where possible, this conduit should be non-metallic and fire-retardant and comply with the requirements of NEC Articles 362 and 800. Metallic conduit offers a path for transients to enter the building, and we do not want this, even if the conduit is properly grounded. Metallic facility must enter/leave through the cable entrance facility/vault, waveguide hatchplates, or the AC service entrance.

CONTENTS

Chapter and Section	Page
4. AC Service Distribution and Equipment Ground Requirements	4-1
4.1 AC Neutral Conductor	4-1
4.2 AC Service Grounding of Separately Derived AC Systems	4-1
4.3 NEC Code Requirements	4-3
4.4 AC Service Grounding Electrode Conductor	4-6
4.5 AC Equipment Ground Conductor	4-8
4.6 CenturyLink AC Equipment Ground Requirements	4-10
4.7 AC Installation Requirements	4-11
4.8 Engine-Alternator Set(s)	4-11
4.9 Grounding for AC Standby Plants	4-12
4.10 Ground Fault Detection/Protection	4-14
4.11 Busduct System	4-17
4.12 AC Power Distribution Service Cabinets	4-17
4.13 AC Equipment Ground Busbars	4-17
4.14 Raceways	4-18
4.15 Lighting Distribution Systems	4-18
4.16 Cord Connected AC Operated Equipment	4-23
4.17 Frame Base Appliance Outlets	4-26
4.18 Trolley Type Busduct	4-26
4.19 Armored Cable	4-27

Figures

4-1	Typical Engine-Alternator that is Not Separately-Derived	4-3
4-2	Atypical Engine-Alternator that is Separately-Derived	4-3
4-3	Transformer with Separately-Derived Source Re-Grounding at the Secondary	4-4
4-4	Transformer with Separately-Derived Source Re-Grounding at the First Disconnect	4-4
4-5	Grounding for Inverter with Maintenance Bypass (Not Separately-Derived) ...	4-5
4-6	Grounding for Inverter without Maintenance Bypass (Separately-Derived)	4-5
4-7	Typical Large UPS with an Input Isolation Transformer	4-6
4-8	Typical AC Service Grounding Electrode Arrangements.....	4-7
4-9	Single ACEG Conductor Serving Multiple AC Circuits in a Common Conduit Run	4-15
4-10	Requirement For Grounding Frames Mounting AC-Operated Equipment Units	4-16
4-11	Typical Arrangement of ACEG Conductors at the Service Entrance and Standby Equipment	4-19
4-12	Typical Standby Engine Room Grounding Scheme for an OPGP Office	4-20
4-13	Typical Standby Engine Room Grounding Scheme for a PANI Office.....	4-21
4-14	Typical Above Ground Fuel Tank/Steel Containment Tank and Outside Standby Engine Grounding Scheme	4-22
4-15	Typical Busduct System Equipment Grounding Arrangement for a 3-Phase, 3-Wire System.....	4-23
4-16	Typical Power Distribution Cabinet Equipment Grounding Arrangement	4-24

4. AC Service Distribution and Equipment Ground Requirements

This section summarizes rules found in the National Electrical Code (NEC), and clarifies and adds where needed. Note that this is only a summary. As a general rule, the NEC is more widely applicable to all types of AC wiring.

CenturyLink policy limits the entrance/exit of any metallic cable to the AC service entrance, the CEF (see Chapter 6), or a waveguide hatchplate (see Chapter 7).

4.1 AC Neutral Conductor

The neutral conductor is usually grounded at the service transformer by the serving utility and must always be grounded at the electric service disconnect. The neutral is not connected to any more grounded objects beyond this point (except for with separately derived sources as per the following section). Neutrals are insulated current carrying conductors and connection to a grounded object would create a load current path through the grounded objects in parallel with the neutral conductor. A neutral conductor may only be used as a source of ground reference at the main panel. It cannot be emphasized too strongly that a neutral (grounded) conductor is not a grounding conductor. It is a single point grounded current carrying circuit conductor (see NEC Article 250.142). In order to maintain the single point concept, neutral bus bars installed in AC distribution facilities must be insulated from mounting framework. Special care must be exercised during installation to ensure that an inadvertent connection between neutral and grounded metal does not occur anywhere on the load side of the service equipment (one example of how this might happen occurs when a new main house service panel is installed, making the old one a distribution panel; and the electrical contractor fails to remove the neutral to ground bond in the old panel).

4.2 AC Service Grounding of Separately Derived AC Systems

AC systems that receive power through a transformer; or by means other than direct connection to a secondary system, are found in COs (note that where only an autotransformer is found, it does not create a separately derived source). These systems with a neutral conductor require ground reference. Per Code (to prevent ground current flow on grounding conductors), the neutral on the primary side of a transformer cannot be extended to provide ground reference to the secondary side. Therefore, a separate dedicated (see NEC Article 250.121) grounding electrode conductor must be extended from the neutral of each such separately derived system to a ground reference source (see NEC Article 250.30, and Figure 4-3, which comes from the NEC Handbook). A floor CO GRD or OPGP / PANI MGB bus is an optimal point for obtaining ground reference (along with building steel). (The grounding electrode conductor shall be sized in accordance with NEC Table 250.66.) In addition, the neutral and ACEG must be bonded at the output. This bond (which may be internal to the equipment) and the grounding electrode reference can be at the output terminals, or at the first distribution panel (unless that panel is more than 25' away – see NEC 240.21C3, and Figure 4-4, which comes from the NEC Handbook).

Standby engine-alternators (see Figure 4-1, which comes from the NEC Handbook), and inverters with a maintenance bypass (see Figure 4-5), are not normally separately-derived sources, and are normally controlled through automatic or manual switching so that the standby supply is never normally adjoined to the commercial supply. In wire-connected services the neutral conductor of the standby supply must be permanently connected (bonded) to the neutral of the commercial secondary service. The grounding electrode conductor of the secondary service system, therefore, suffices as a single point ground reference for both the standby and commercial systems, and such systems do not require a separate grounding electrode conductor. A few exceptions apply:

- When an engine is located in a separate building (or other enclosure) which has its own ground electrode, the standby system neutral shall also be bonded to the ground electrode in its own building. (Note that this does not require engines in outdoor enclosures to have their own ground electrode system; but if they do, there should be a neutral to ground electrode system connection.)
- UL 2201 requires small portable engine-alternators less than 15 kW to have the engine-frame and the neutral bonded at the set, making them de facto “separately-derived”. However, they will usually serve a site having a “hard-wired” (bonded) neutral (non-separately-derived). This situation (which can be identified by using a clamp-on ammeter to look for significant current on the ACEG between the engine and building) can be made safer by limiting the genset connecting cord distance to 15 feet, and by ensuring that the inlet is less than 10 feet from the HSP MGN-ACEG bond. This type of arrangement should only be used for backup powering when AC is lost (not for long term temporary backup), and cannot be used when the site has a ground fault detection system. Driving a ground rod at the engine and bonding to it (see Figure 4-2, which comes from the NEC Handbook), can improve the situation.
- When standby engine-alternators have an output transformer (which is rare), they are considered separately derived sources (unless it is an autotransformer, since it has a direct primary to secondary connection in the transformer), and those NEC rules referenced in the first paragraph of this section apply.
- DC-preferred -48 VDC-fed inverters are usually (see Figure 4-6) separately-derived sources (except where there is a maintenance bypass with a hardwired/non-switched neutral), and those NEC rules referenced in the first paragraph of this section apply (other than inverters and converters in the isolated ground plane, whose output grounding is to the nearest isolated frame or frame ground bar, as shown in Figure 8-5).
- Any UPS containing an input isolation transformer; or any other step-up or step-down transformer (other than an autotransformer) is considered a separately derived source (see Figure 4-7, which comes from IEEE 1657), unless a maintenance bypass goes around the transformer(s), and those NEC rules referenced at the beginning of this section apply.

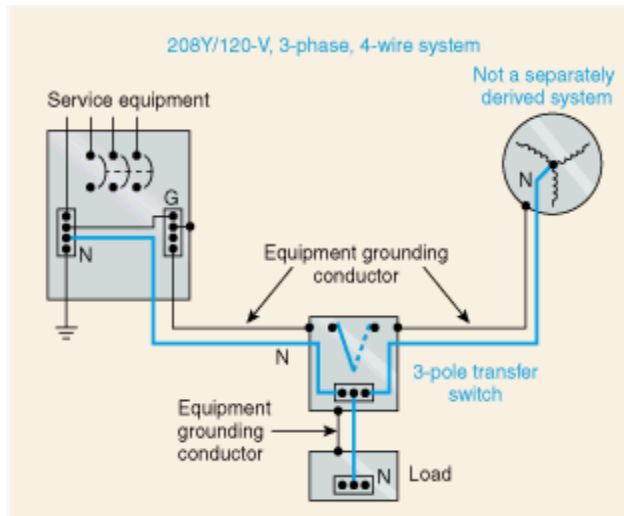

Figure 4-1: Typical Engine-Alternator that is Not Separately-Derived

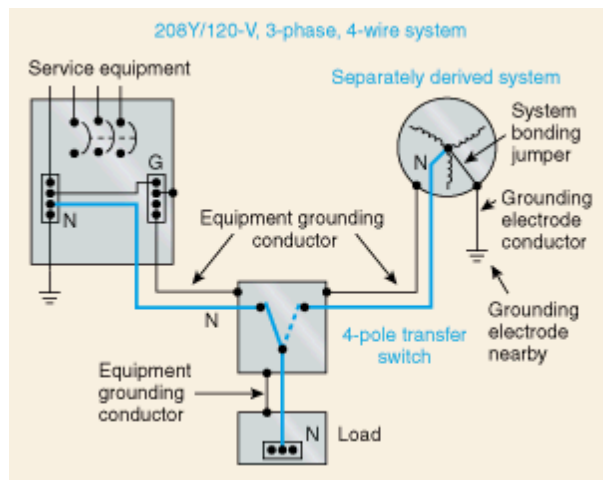

Figure 4-2: Atypical Engine-Alternator that is Separately-Derived

4.3 NEC Code Requirements

The preceding information summarizes basic National Electrical Code requirements pertaining to grounding of neutral conductors for service of 600 volts or less. Individual installations must conform to all of the requirements expressed in the Code for the service furnished. Refer to Article 200 for requirements for neutral conductors and Article 250 for requirements for service grounding. In addition, refer to Article 702 for general engine-alternator (Optional Standby Systems) provisions. Where local Codes differ from the NEC, installations shall conform to the local code requirement.

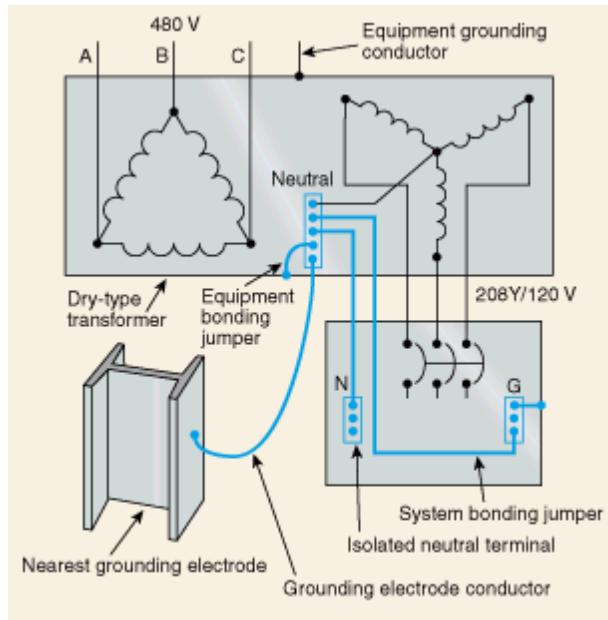

Figure 4-3: Transformer with Separately-Derived Source Re-Grounding at the Secondary

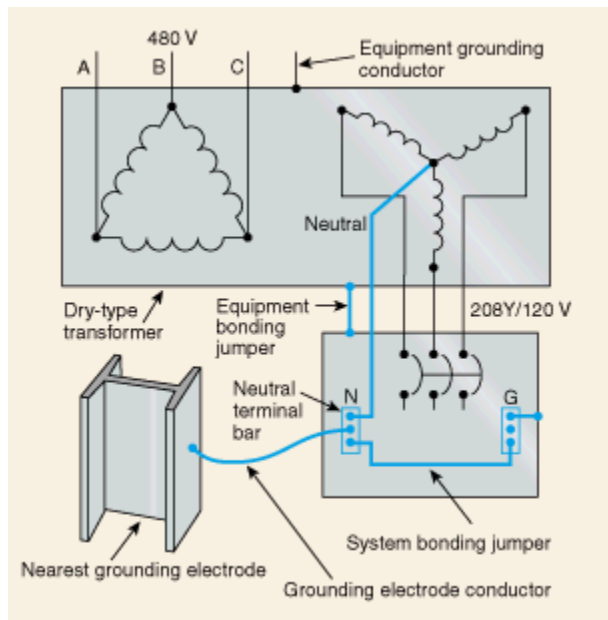

Figure 4-4: Transformer with Separately-Derived Source Re-Grounding at the First Disconnect

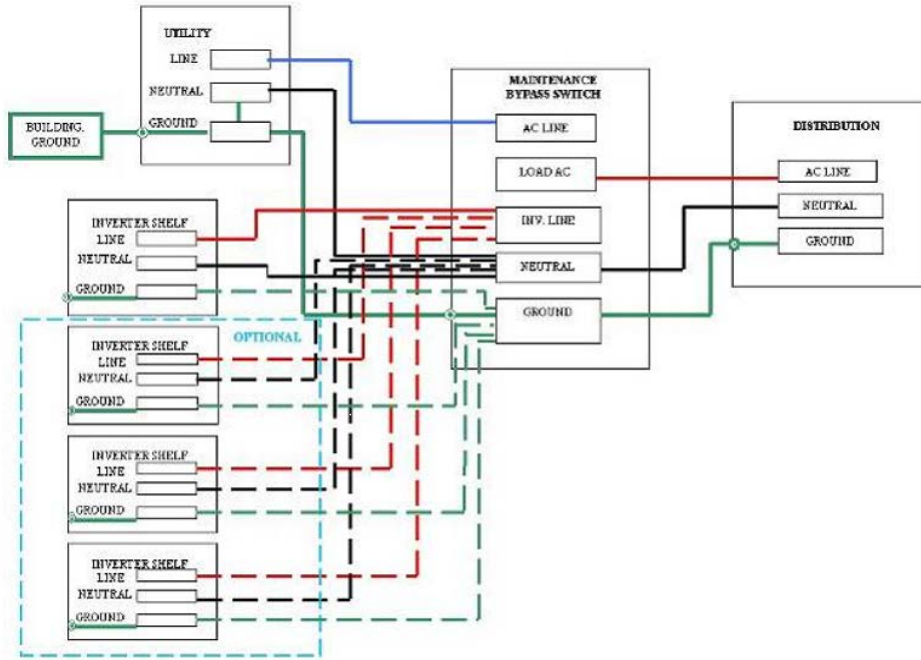

Figure 4-5: Grounding for Inverter with Maintenance Bypass (Not Separately-Derived)

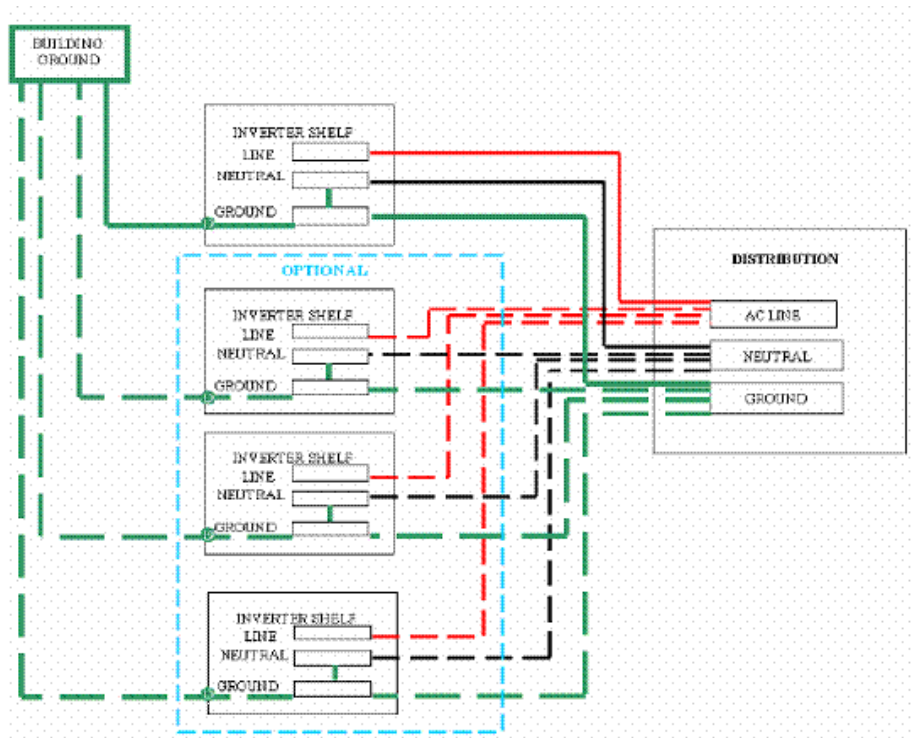

Figure 4-6: Grounding for Inverter without Maintenance Bypass (Separately-Derived)

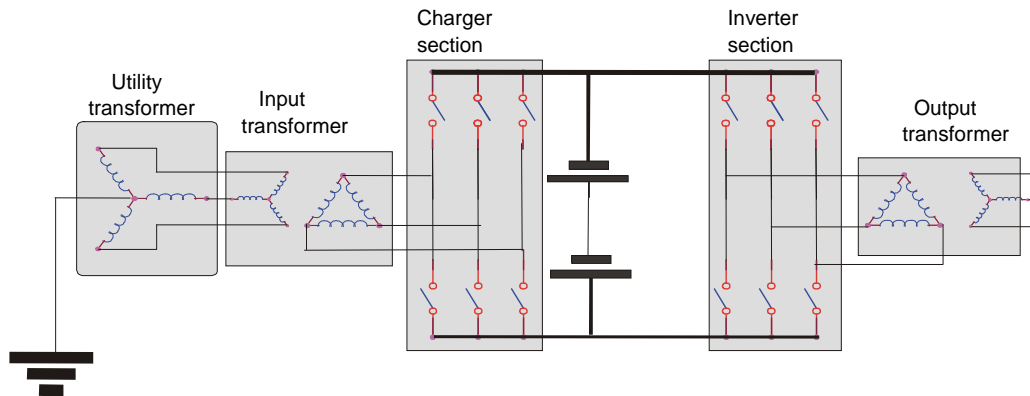

Figure 4-7: Typical Large UPS with an Input Isolation Transformer

The NEC requires that the path to the ground from circuits (feeder and/or branch), equipment, and conductor enclosures shall:

- Be permanent and continuous.
- Have capacity to conduct safely any fault current to be imposed on it.
- Have sufficiently low impedance to limit the voltage to ground and to facilitate the operation of the circuit protective devices.

To ensure continuity and low impedance, and to provide additional insurance against noise generated in AC systems, all circuits shall include the ACEG "green-wire" sized per table 250.122 of the NEC, even when metallic conduit or other raceway is used.

4.4 AC Service Grounding Electrode Conductor

An AC service grounding electrode conductor is required for each secondary AC service circuit (per NEC 250). Its method of termination differs if the AC is grounded or ungrounded. The conductor is normally provided by the electrical contractor at the time of installation of AC switching equipment. In a grounded AC system application, the grounding electrode conductor is terminated at one end to the neutral conductor of the AC system, generally at the location of the service disconnect equipment. It may be connected (bonded) to the neutral at any point on the supply side of the service disconnect equipment. It must never be connected on the load side of the disconnect equipment. At the point of termination, the AC service circuit neutral conductor is bonded to the metallic enclosure of the AC system equipment. This bond forms a path via the neutral to the transformer for fault currents that may be impressed on conduits, equipment ground wire or other metal forming the equipment ground plane.

- In an ungrounded AC system, a neutral is not employed and the grounding electrode wire is bonded to the enclosure of the service disconnect equipment. The other end of the grounding electrode wire is connected to a ground electrode. For typical bond and AC grounding electrode arrangements, see Figure 4-8.
- The AC service grounding electrode conductor and associated bonds at the service disconnect equipment and water meter are normally installed by the electrical contractor as directed by CenturyLink specifications. The conductor size shall be in accordance with NEC Article 250.66.

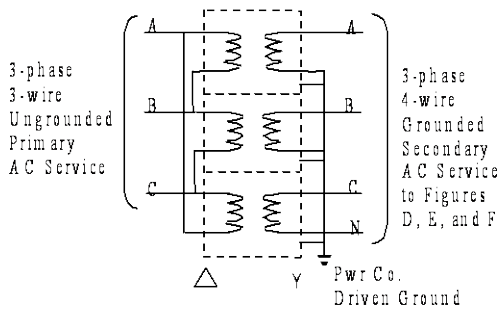

A. Typical Delta-WYE Service Transformer Arrangement

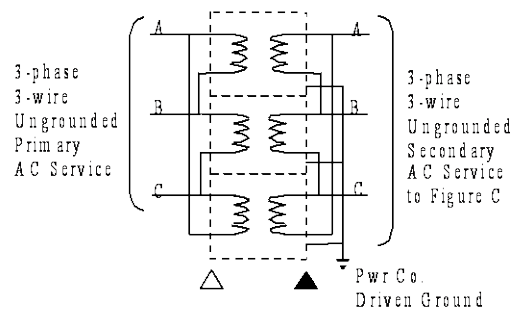

B. Typical Delta-Delta Service Transformer Arrangement

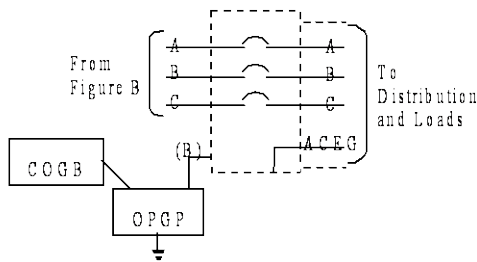

C. Service Disconnect Equipment Ungrounded AC Service
Water Pipe or Driven Ground Electrode

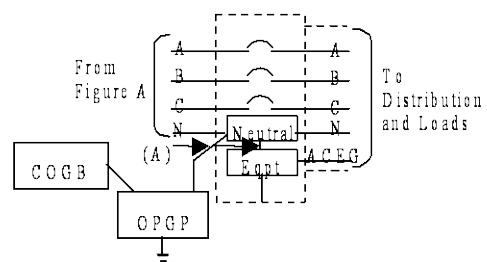

D. Service Disconnect Equipment Grounded AC Service
Water Pipe or Driven Ground Electrode

Notes:

1. (A) and (B) Denotes wires sized Per NEC 250.66
2. Figures A and B represent typical three-phase transformers wired to provide grounded or ungrounded service
3. Figures C and D show typical service grounding arrangements
4. The figures illustrate that fault current impressed on the equipment system (ACEG) has a low impedance path to the current source (transformer) only in grounded AC systems

Figure 4-8: Typical AC Service Grounding Electrode Arrangements

- It is preferable that the AC service grounding electrode conductor be insulated, stranded wire, run open or in a nonmetallic raceway; and installed per NEC 250.64. Preferably, it should be surface supported and visible for inspection. Where run through walls, partitions, etc., the wire should be routed through nonmetallic sleeves, if possible. It should not be routed through metal that forms a ring or in metallic conduit, where avoidable. If run in metallic raceway, the conductor must be bonded to any enclosing ring, and the raceway must have continuity with the terminating points of both ends of the grounding electrode wire. Suitable continuity is assumed when:
 - The raceway is terminated at the disconnect equipment enclosure with approved electrical raceway couplings or a bond conductor, and the enclosure is internally bonded to the AC system neutral (grounded AC Service).
 - The raceway is bonded to the OPGPB or other grounding electrode, or bonded to the AC service grounding electrode conductor at the terminus of the raceway.
 - Intermediate points of the raceway discontinuity are bonded at every such point to the grounding electrode conductor run therein. Such bonds shall be of the same size as the grounding electrode conductor.
- It is preferable that the AC service grounding electrode conductor be tied to 1-2 ground rods driven by the electrician at the time of meter installation, and that those rods not be connected directly (except through the MGN bus and OPGP / MGB PANI) to the driven ground system for the site. This allows the site's driven ground electrode system to be disconnected for 3-point "megger" testing without fear of losing site ground reference.

4.5 AC Equipment Ground Conductor

An AC Equipment Ground (ACEG) conductor provided in the same raceway with phase conductors (and sized per NEC 250.122) ensures that minimal impedance to the flow of fault current will be encountered. The following requirement shall, therefore, be applied to the design of AC distribution systems in CenturyLink buildings. An ACEG conductor, enclosed in the same raceway with phase conductors, shall be provided for circuits distributing AC power from a commercial or locally derived power source.

The inclusion of an ACEG conductor in a raceway shall not be counted in determining the ampacity of conductors, in accordance with NEC Article 310.15. The ACEG conductor is not a current carrying conductor.

In a 3-phase grounded circuit, if the neutral carries only the unbalanced current from other conductors in the same circuit it is not counted as well. (If there are harmonic currents present in the neutral conductor, then the neutral shall be considered to be current-carrying and must be counted. The neutral must be appropriately sized if harmonics are likely, in accordance with the NEC. And for sites with lots of switch-mode power supply loads, such as computers, fluorescent lighting ballasts, and switch-mode rectifiers; harmonics are likely.) Therefore, a conduit containing three phases, a neutral and an ACEG may be, within limitations defined (in the NEC), considered as not more than three conductors and need not be derated. The ACEG conductor shall be included in calculations of allowable percentage of conduit fill defined in Chapter 9 of the NEC.

AC service phase conductors in sizes 1/0 AWG and larger may be run in multiple, provided the arrangement is such to assure equal division of total current among all conductors involved. When run in multiple raceways, separate equipment ground conductors shall be run in each raceway. All of the multiple equipment ground conductors shall be of the same length and size and terminated in the same manner. Size of the equipment ground conductors shall be determined as follows:

- Determine number and size of phase and neutral conductors required for load.
- Determine the number of raceways required to accommodate the phase and neutral conductors. Each raceway shall contain an equal number of same-sized conductors of each phase, a neutral conductor (if grounded service is provided), and an equipment ground conductor.
- Determine the ampacity rating (fuse or non-adjustable circuit breaker) of the overcurrent device protecting phase conductors.
- Determine the size of individual equipment ground conductors according to NEC Table 250.122. Derating of these ACEGs is not permitted. Each raceway shall contain an ACEG sized per NEC 250.122 to the protection device.

The AC equipment ground conductor in raceways or conduit shall be green-insulated, or bare wire (stranded or solid). AC distribution wire shall be THWN or THHN type.

When armored cable is used for AC service, the equipment ground conductor shall be the same size as phase leads. The entire exposed portion of the EG conductor shall be green color coded or made bare for purpose of identification.

When multiple AC circuits are run in a common raceway (see Figure 4-9), the ACEG conductor must be one or more single conductors of size required by the ampacity rating or setting of the largest overcurrent device of the associated circuits. The single ACEG conductor shall be tapped and branched, reduced and extended with each branch circuit emanating from the common raceway to each unit in which phase leads terminate. Reduction of the branch ACEGs shall be in accordance with requirements of the branch circuit overcurrent device ampacity or setting. The main ACEG conductor shall be bonded to the raceway at every point of emission of any branch circuit.

It is imperative that a continuous conductive path exists throughout both the ACEG conductor and any enclosing metallic material. Therefore, when the ACEG and phase leads emit from a conduit or other raceway into free air or a non conductive fitting, the ACEG conductor and conduit must be bonded together so that the conduit maintains continuity to the termination point of the ACEG conductor. Similarly, any breaks in conduit or enclosure continuity must be bonded. Generally, the connection provisions of standard electrical fittings and enclosures utilizing bolts, screws, threads, pressure fittings and similar devices are considered adequate for electrical continuity, although bonding at each J-box (as shown in Figure 4-9) is recommended.

A floor mounted frame, cabinet or similar metallic structure provided for the support of an AC operated equipment unit, served by an AC equipment ground system that conforms to CenturyLink requirements (see paragraph 4.6), is considered to be adequately grounded via the AC equipment ground system. When such frames are mounted in floor areas also occupied by communication equipment grounded to a CO GRD system, it is required that these frames be bonded to the CO GRD system also. This is done by extending a No. 6 AWG framework ground bond from the frame to a suitable point on the CO GRD system. When the AC operated equipment is served from an AC service cabinet located on other than the same or an adjacent floor, a framework ground bond must be provided (see Figure 4-10). Provision of framework ground bonds ensures that low impedance exists between grounded objects in close proximity, which reduces the probability that a dangerous difference in potential can develop between the systems.

ACEG conductors shall never be connected (bonded) to the AC neutral termination point in any equipment enclosure.

4.6 CenturyLink AC Equipment Ground Requirements

Minimum safety requirements specified in the National Electrical Code shall be met by forming the equipment ground system by means of both the metallic raceway and the green equipment grounding (wire) conductors. It has been recognized, however, that these forms of grounding are not always effective in shielding communication circuits from noise generated in AC systems. Supplementary requirements for a more effective AC equipment grounding system to be used in CenturyLink buildings housing communication equipment are listed below.

Supplementary requirements are as follows:

- AC conductors shall be run in metallic raceway exclusively, except for circuits run within equipment frameworks. (i.e. end guards or guard rails for AC outlets).
- When equipment is powered by an AC cordset, the cord shall not be longer than required (coiling excessive lengths can create mutual inductance).

4.7 AC Installation Requirements

The reliability of a grounding system is as dependent on careful and proper installation as it is on the proper choice of materials. Improper preparation of surfaces to be joined to make an electrical path, loose joints and corrosion can introduce impedance that will seriously impair the ability of the ground path to protect personnel and equipment and to absorb transients that can cause noise in communication circuits.

The following functions are particularly important to ensure a reliable ground system:

- Metallic surfaces to be joined shall be prepared to a bare, bright finish (see NEC Article 250.12).
- Current carrying metallic surfaces shall be coated with corrosion preventive compound before joining.
- Raceway fittings shall be made up tight to provide a permanent low impedance path for fault currents.

A non-oxidizing agent shall be applied to inhibit corrosion wherever the possibility of corrosion formation in ground conductor joints exist.

A "DO NOT DISCONNECT" tag should be placed on every non-welded ground conductor terminated to an OPGP (PANI MGB) or COGB (PANI FGB). In addition, a tag stamped with the location of the far end termination will be employed on each grounding conductor, to aid in conductor identification (this requirement is waived when the grounding conductor is short in length, and both ends can be viewed from the same spot).

Installation of metallic raceways shall be in conformance with requirements outlined in the National Electrical Code, Section 386; and local codes.

AC equipment ground conductors shall be provided in all raceways, such as:

- Buildings housing communication equipment
- In AC service, feeder and branch circuit raceways serving the following:
 - Communication equipment
 - Building service equipment

4.8 Engine-Alternator Set(s)

Engine-alternator sets always require an equipment ground conductor in the conduit or the metallic raceways that contain phase leads from the alternator. The equipment ground conductor(s) shall be furnished in accordance with paragraph 4.5.

The equipment ground conductor(s) shall terminate within the engine-alternator cabinet provided for termination of phase leads. Termination may be made on a bus bar or ground stud electrically bonded to the cabinet or directly to the cabinet interior with terminal lugs. The cabinet must be electrically bonded to the set frame by bolting or by a bonding strap or equivalent means to provide ground continuity between the entire set and the equipment ground conductors.

If phase and equipment ground conductors are enclosed in flexible conduit for vibration control (this would typically be done where the raceway interfaces to the alternator), the electrical continuity must be maintained by bonding, using an insulated, stranded No. 6 AWG conductor across the flexible section.

The neutral of the alternator shall not be bonded to the ACEG conductor or set frame when the set is located in the same building as the main AC service board. The neutral shall be bonded to the ACEG conductor only when the set is located in a separate building equipped with its own ground electrode.

4.9 Grounding for AC Standby Plants

The primary control cabinet for the standby set shall be bonded to the metallic (steel) sub-base or chassis. These bonds should be made with bare, stranded, or ribbon conductors, designed and installed to withstand the vibration generated by the standby set. Figure 4-12 shows a general grounding scheme for a standby engine room in a traditional isolated-integrated office. A minimum #2 AWG stranded insulated conductor shall be run from the OPGP (or alternatively to a COGB on the same floor) to the standby engine room. (It may be advisable to terminate this cable on an engine room ground bar and run all other cables to it for traceability purposes.) Ground the standby engine with a #2 AWG, and all other components with #6 AWG stranded insulated conductors. If the fuel tank is located outside, then the metallic fuel lines must be bonded with a minimum of #2 AWG, since they constitute a ground source. If flexible piping is used on the fuel lines where they enter the building, there must be a bond around the flexible section using a minimum #6 AWG. The following must be bonded to the #2 using a minimum #6 insulated stranded copper grounding conductor:

- Metallic fuel tanks (day and main)
- Fuel piping (metallic)
- AC control panel or cabinet
- Start battery stand
- Exhaust pipe and radiator pipes
- Air dryer
- Battery charger
- Transfer switch cabinet

- Exhaust/intake fans that have a flexible connection to metal louvers
- Fuel monitors and/or gauges
- Other raceways to the exterior (i.e., metallic conduits to tank alarms, radiator fans, etc.)
- Metallic walls and metallic doors/frames with an outside ground source

Figure 4-13 shows a general grounding scheme for a standby engine room in a traditional PANI office. A 2/0 AWG stranded insulated conductor shall be run from the P section of the PANI MGB (or alternatively to the PANI FGB) to the standby engine room. Ground the standby engine with a 2/0 AWG, and all other “producer” components (such as indoor fuel tanks, exhaust stacks, and intake air louvers) with outdoor exposure with minimum #6 AWG stranded insulated conductors. If the fuel tank is located outside, then the metallic fuel lines must be bonded with a minimum size of #2 AWG, since they constitute a ground source. If flexible piping is used on the fuel lines where they enter the building, there must be a bond around the flexible section using a minimum #6 AWG. A separate 2/0 AWG stranded insulated conductor shall be run from the N section of the PANI MGB (or alternatively to the PANI FGB) to the standby engine room to ground all other metallic components in the room (with minimum #6 AWG).

Note that when Engines are located in enclosures separate from the building, the transfer and AC switchgear and engine control cabinet located within the building do not have to be separately grounded to the DC grounding system unless they are not bonded to the ACEG.

Metallic fuel tanks (buried or above ground) located outside of the building enclosure shall be grounded to the driven ground system. Coordinate the grounding of the tanks with any tank corrosion protection system. Bond Metallic or metal-braided fuel lines to the CO ground system at building entry. Other incidental metallic items, like fuel tank ladders and remote radiators shall be bonded to the driven ground system. (In states where the PUC requires that the site be grounded to RUS standards, the outdoor engine frame must be grounded to the P section of the PANI MGB.)

Standby engines outside the main building enclosure shall be grounded to the driven ground system. If these engines are in metal enclosures, that metal shall be grounded to the driven ground system (see Figure 4-13). If there is metallic within 6 feet of this enclosure, it too must be bonded (fences require a bond to at least one post [preferably two], then ensured continuity to other fence sections and gates). Roof-mounted engines should also be grounded to a lightning protection system, if one exists (see Chapter 7).

To limit step/touch potentials, new above-ground outdoor metallic fuel tanks and metallic outdoor engine enclosures that aren't within 6' of an existing ground electrode shall have a rod driven that is bonded to an existing ground electrode field.

When the engine exhaust stack is higher than the building roof, it can be an unintended lightning rod (it can serve as an intentional lightning rod if the metal thickness is $3/16$ " or greater). If a roof lightning protection system exists, bond the stack and thimble to it. If a roof protection system doesn't exist, it is preferable to attach a # 2 AWG from the external stack, run it outside of the building, and connect it to the ground electrode field (this keeps any lightning which hits the stack from entering the building). Also, attempt to bond the thimble (through which the exhaust stack exits the building) to this # 2 conductor. When this can't be done, ensure to bond the stack per Figure 4-12.

When the standby AC neutral is switched by a transfer device, the standby AC system is classified as a separately derived AC source. Service grounding for such systems shall conform to the provision of the NEC governing separately derived systems, including Articles 250.20, 250.26, and 250.30. When local codes differ from the NEC, follow the requirement acceptable to the authority having jurisdiction.

Standby sets whose nominal line-to-line voltage is greater than 480 V shall be treated as a separately derived system, and shall have their neutral solidly grounded (Delta outputs with a corner-derived neutral can be resistance-grounded). A direct and continuous connection shall be made from the neutral to the nearest COGB with a grounding conductor sized per NEC Table 250.66. A second independent connection shall be made between the neutral and the metal frame of the set.

When the standby AC neutral is not switched by an automatic transfer device (it is normal for the neutral to not be switched), the following provision should apply. For standby sets of 480 V or less, where a solidly grounded commercial power system is used, the neutral of the set shall not be grounded by connecting it to the ACEG of the set. An acceptable method of grounding the neutral of the set is to connect it to the neutral of the commercial power at the neutral bus of the transfer switch or wired through the transfer switch to the main AC entrance panel neutral bus, if such a bus is not provided for in the transfer panel. In addition, the neutral and the phase lead(s) of the set should be the same size.

4.10 Ground Fault Detection/Protection

Where ground-fault detection and protection is required (although NEC Articles 230.95, 701.16D and 701.26 only require it on commercial entrances rated at least 480 VAC and 1000 Amps, Tech Pub 77385 requires it for alternators of 480 VAC and higher and/or 1000 Amps or greater), grounding the neutral at two points can lead to false operation of sensing devices, because part of the neutral current will flow in the frame ground paths (see NEC Article 250.142). A net summing type of sensing device should be used.

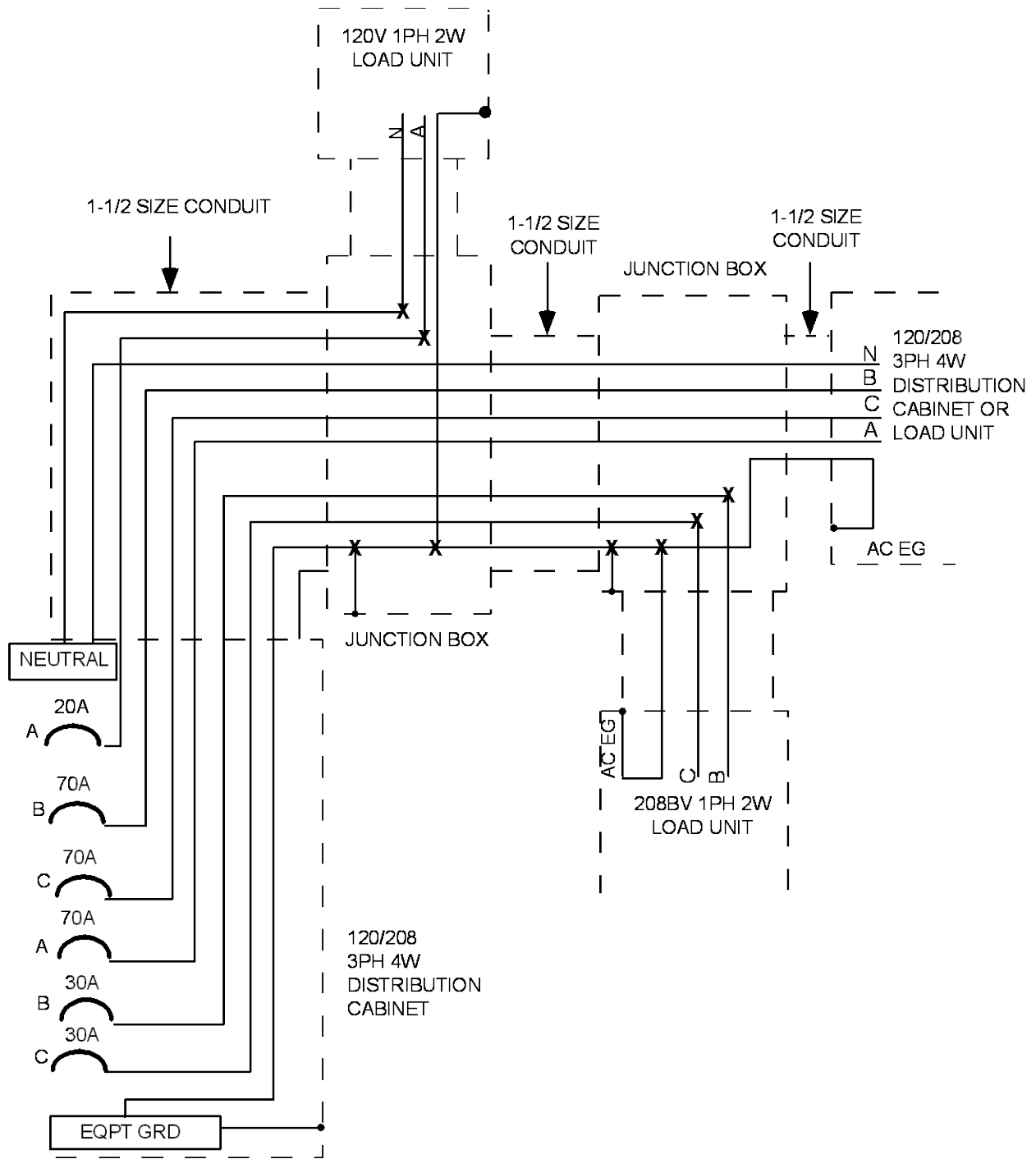
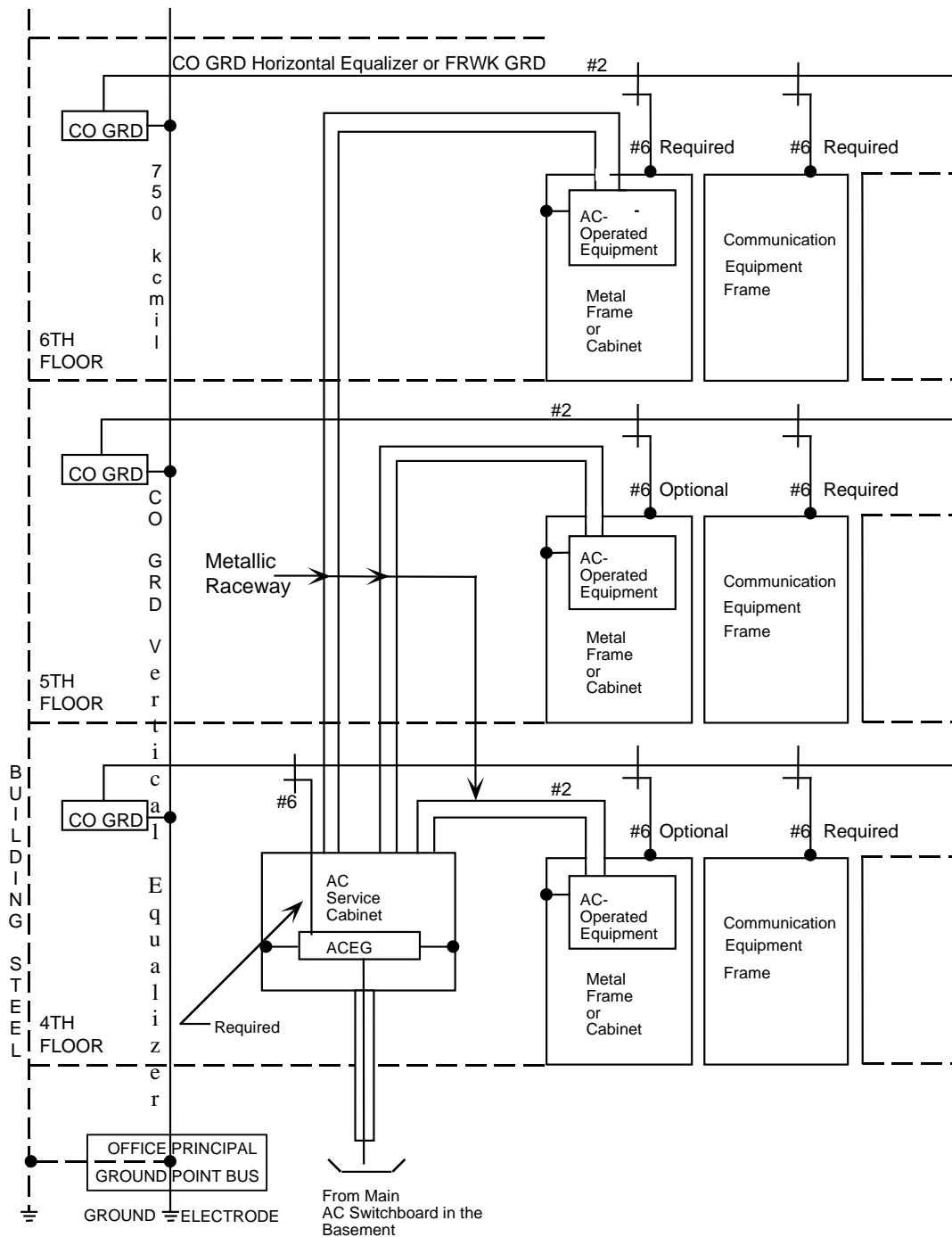

Figure 4-9: Single ACEG Conductor Serving Multiple AC Circuits in a Common Conduit Run



Notes:

1. Although not shown, each feed is run with an ACEG.
2. The required #6 shown going from the AC cabinet ACEG bar to the CO Grd system is only for integrated (non-isolated) ground planes. For isolated ground planes, see Figures 8-5 and 8-7.

Figure 4-10: Requirement for Grounding Frames Mounting AC Operated Equipment Units

4.11 Busduct System

Busduct components used to supply floor mounted DC rectifiers in Central Office power plant installations are manufactured by outside suppliers to CenturyLink specification requirements. Equipment ground continuity is required throughout the busduct system. Each busduct section must have a connection between case and equipment ground conductor.

4.12 AC Power Distribution Service Cabinets

AC distribution cabinets always require an ACEG conductor in conduit or other metallic raceway(s) that contain phase feeder leads to the cabinet. The ACEG conductor provided with the feeder circuit is considered adequate for providing framework grounding for the AC distribution cabinet and connected AC operated equipment only when the ACEG conductor obtains ground reference (CO GRD or grounding electrode) on the same or adjacent floor to that on which the AC Service cabinet is located. The ACEG conductor provided with the feeder circuit is considered adequate for providing connected AC operated equipment only when the ACEG conductor obtains ground reference (CO GRD or OPGPB) on the same or adjacent floor to that on which the AC Service cabinet is located. Otherwise, the cabinet shall be framework grounded to the floor CO GRD system, using a No. 6 AWG wire (see Figure 4-10). ACEG conductors shall terminate in the interior of the cabinet enclosure on an equipment ground bus bar electrically connected (bonded) to the cabinet enclosure, if provided. Otherwise, each ACEG conductor shall terminate, using terminal lugs bolted to the cabinet enclosure, near the raceway entry point.

The neutral bar provided in AC distribution cabinets must be insulated from the enclosure and the equipment ground bar. Extreme care must be exercised to insure that the neutral does not have electrical continuity through mounting apparatus, terminal mounting bolts, or otherwise to the cabinet enclosure. Figure 4-15 illustrates typical AC circuits that terminate in an AC distribution cabinet. All raceway is metallic conduit that is electrically continuous between the AC distribution cabinet and load enclosures.

The AC distribution cabinets serving rectifiers are referred to by the special name of PDSC (Power Distribution Service Cabinet). In data center or computer room environments, they are often referred to as PDUs (Power Distribution Units).

4.13 AC Equipment Ground Busbars

Certain equipment bays and cabinets provided for distribution of AC service are equipped with equipment ground bus bars by the manufacturer, for the purpose of providing a convenient terminating point for AC equipment ground (green-wire) conductors. Other AC service equipment units may not have such facility furnished. Units in which such terminating facilities may be found include house service boards, power service cabinets, lighting distribution cabinets and other units that may be employed as a distribution point for AC service circuits.

When an equipment ground bus is provided, it is mounted within the equipment enclosure so that it is electrically bonded to the enclosure, and all AC equipment ground conductors shall be terminated thereon. When no ground bus is furnished by the manufacturer, a ground bus shall be provided by the service (installation) supplier.

4.14 Raceways

The AC equipment ground system is composed of two components: metallic raceways (typically EMT conduit), and a network of green insulated conductors. The conductors are extended through the raceways that carry the phase conductors and bonded to the framework of the apparatus associated with the system. The purpose is:

- To enhance the raceway conductivity so as to ensure a low impedance path for fault current from a point of fault to an overcurrent protective device
- To bond across inadvertent discontinuities in raceway conductance
- To short out noise producing high impedance joints in raceways.

In PANI sites with fire suppression systems (whether water or chemical-based), all types of non-metallic conduit are allowed and encouraged (to prevent violation of the isolated ground planes, of which there are a greater number in PANI offices). In sites without fire-suppression systems (typically NEBS-compliant equipment sites), only fire-rated non-metallic conduit (such as ENT, or treated rigid plastic) is allowed when non-metallic conduit is used. For MDF frames in PANI sites, AC conduit must either be non-metallic, or insulated completely from the frame. In sum, offices using primarily PVC conduit should continue to do so, and offices using primarily EMT conduit should continue that practice.

4.15 Lighting Distribution Systems

AC feeder circuits serving AC distribution panels provided for branch circuit distribution of AC service to lighting fixtures and AC appliance outlets shall include an ACEG conductor. An ACEG conductor shall be provided as described in paragraph 4.5 in each raceway emanating from such panels that contain branch circuits serving switchroom fluorescent lighting fixtures. The ACEG conductor shall be branched and extended so as to terminate at one of the screws that secure the lamp ballast on the interior of every fluorescent lighting fixture. This ballast grounding system is required to ensure a reliable ground path from ballasts for the purpose of suppressing transient voltages emanating from ballast and other components of the lighting system.

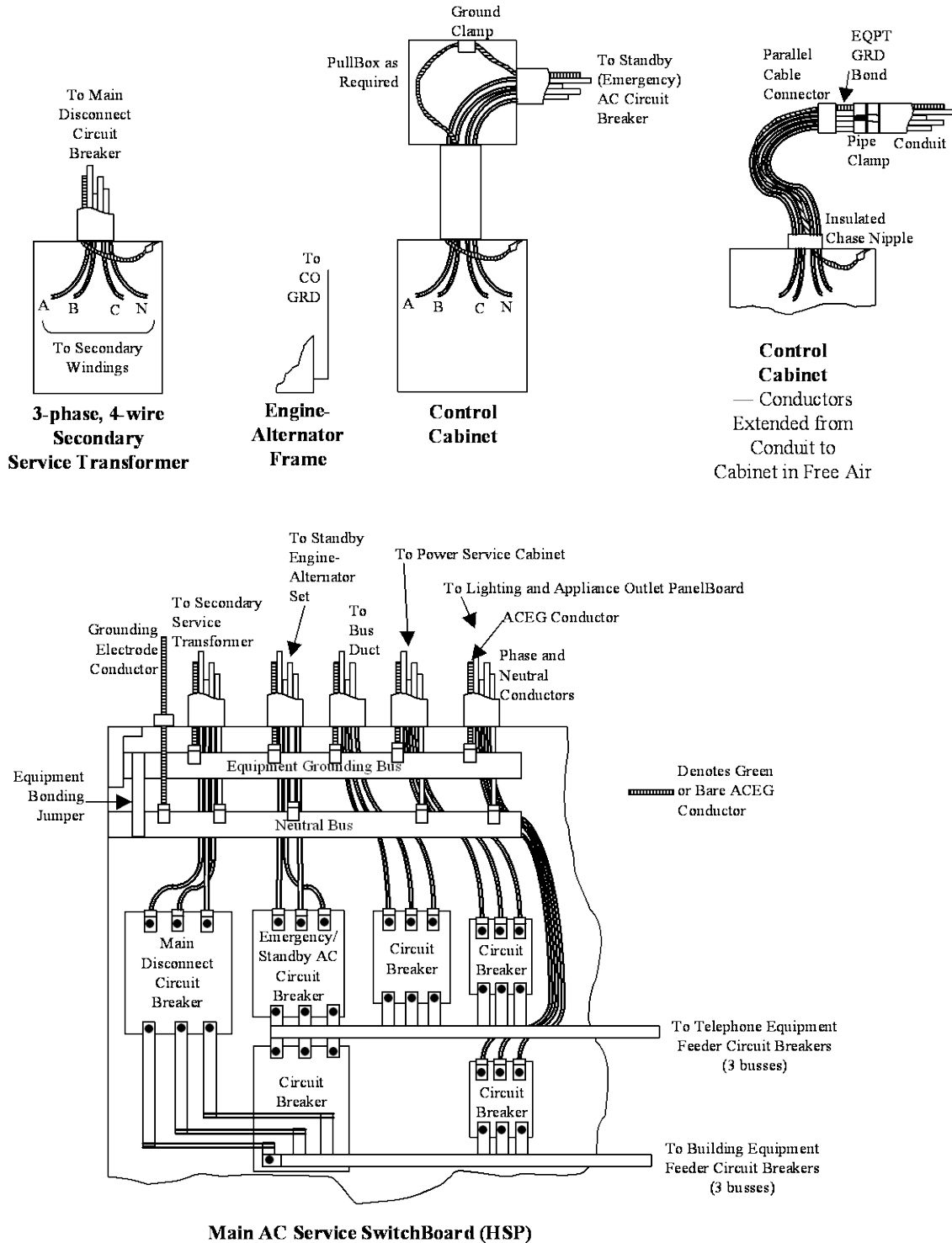
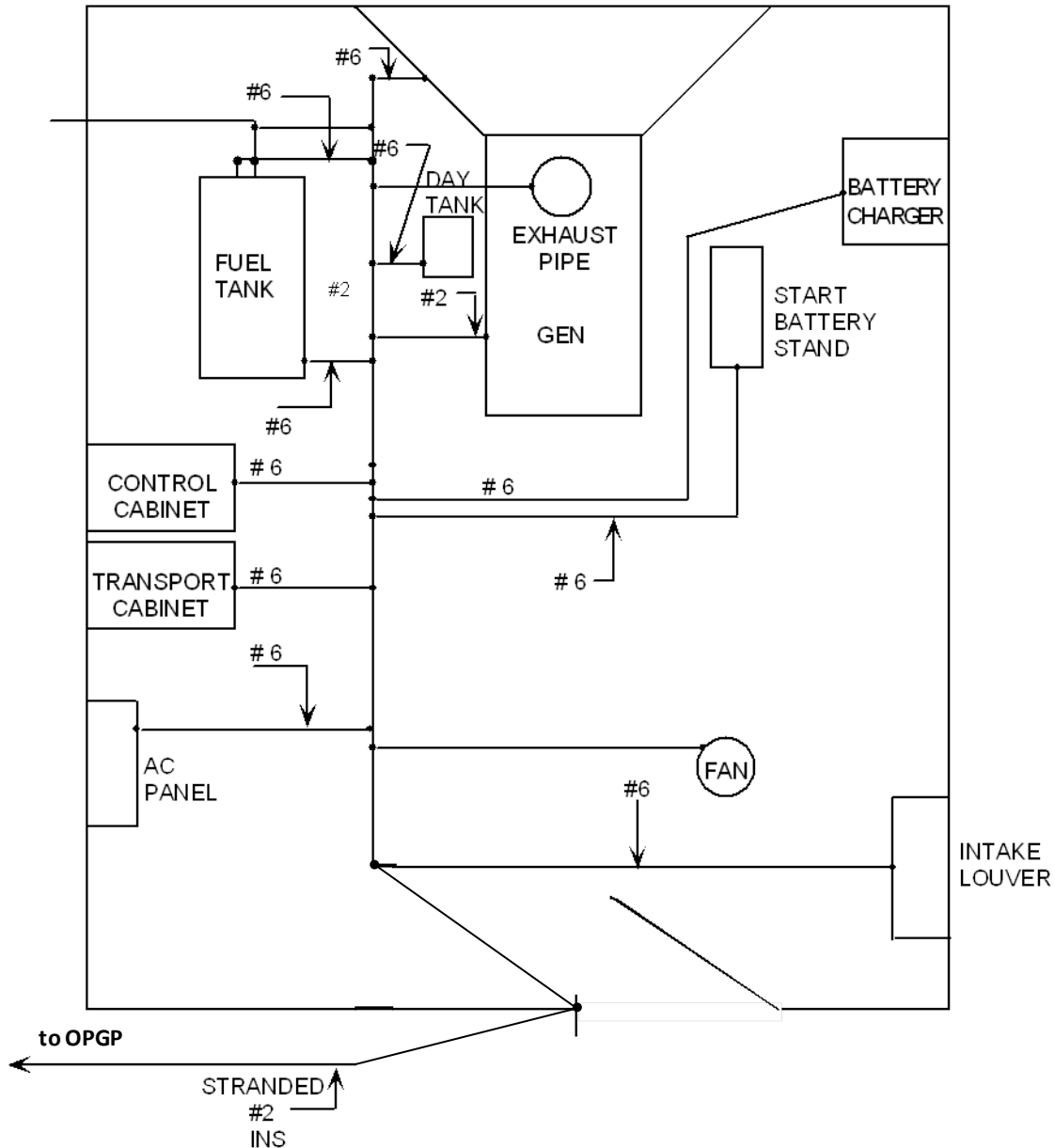

Figure 4-11: Typical Arrangement of ACEG Conductors at the Service Entrance and Standby Equipment



Notes:

1. All connections to the No. 2 AWG will be crimped type connections (C /H- tap connectors).
2. All Connections to equipment will be 2 hole crimp connectors and connected on bare metal.
3. All conductors will be run exposed and attached with cord or plastic ties.
4. No mechanical connections will be accepted
5. RHW (or XHHW) type wire only - bond around flex conduits (feeders only)
6. All splices shall point towards the ground source if possible (i.e., towards the source of the #2 coming from the COGB or OPGPB)

Figure 4-12: Typical Standby Engine Room Grounding Scheme for an OPGP Office

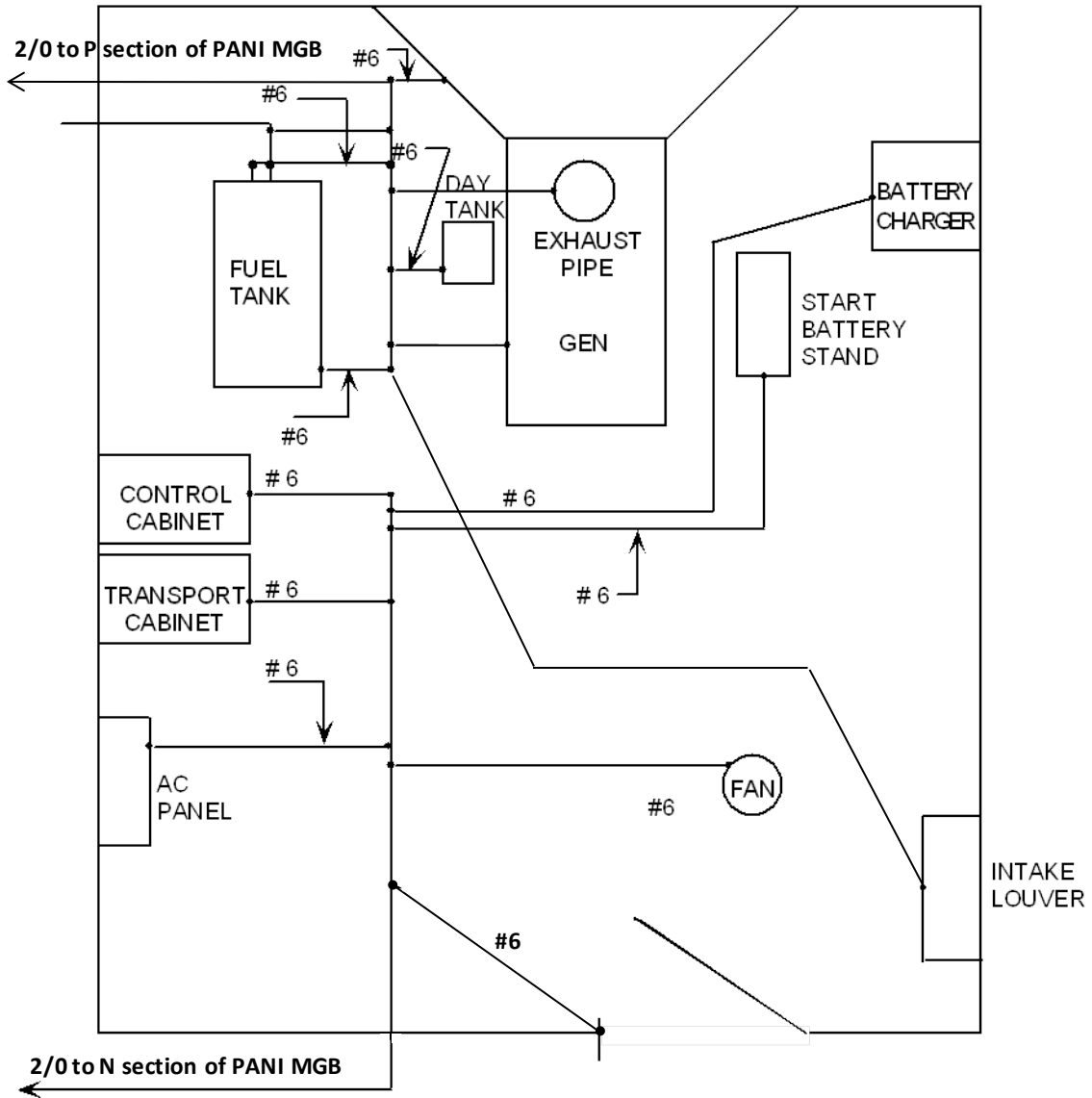
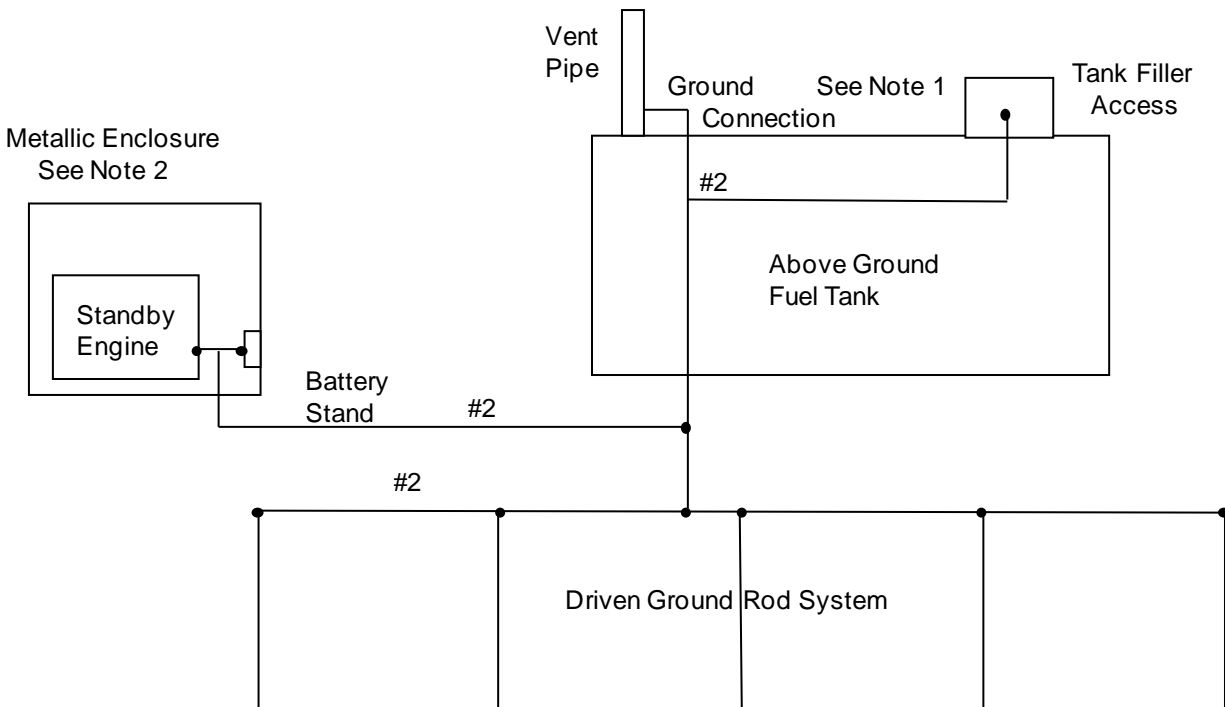

Figure 4-13: Typical Standby Engine Room Grounding Scheme for a PANI Office



Notes:

1. It is not necessary to ground tank vent/access points if the tank has other ground point(s) and continuity of less than 0.1 Ohms can be established/verified between the vent/access points and the ground point(s). If such continuity between the tank ground and the vent/access pipes/points cannot be verified, and the vent/access pipes don't have ground tabs available use a pipe clamp (see Figure 3-8, sketch E)
2. If the standby engine is located outside the building in a metallic enclosure, the metallic enclosure, standby engine and battery stand must be grounded to the driven ground system.
3. All connections must be made with copper two-hole crimp type connectors. Paint must be removed on painted surfaces and coated with an anti-oxidant compound before making connections.
4. When the primary driven ground system cannot be accessed, bring a #2 AWG solid tinned bare copper conductor from the external tank and/or engine, and run it outside the building to the OPGP. If an exterior run is not feasible, it may be run inside the building (in this case, it can be a minimum #2 AWG insulated or bare conductor), but as far away from equipment as possible, and as near as possible to the buildings outer walls.
5. See Figure 7-1 for proper grounding of a direct-buried tank.

Figure 4-14: Typical Above-Ground Fuel Tank/Steel Containment Tank and Outside Standby Engine Grounding Scheme

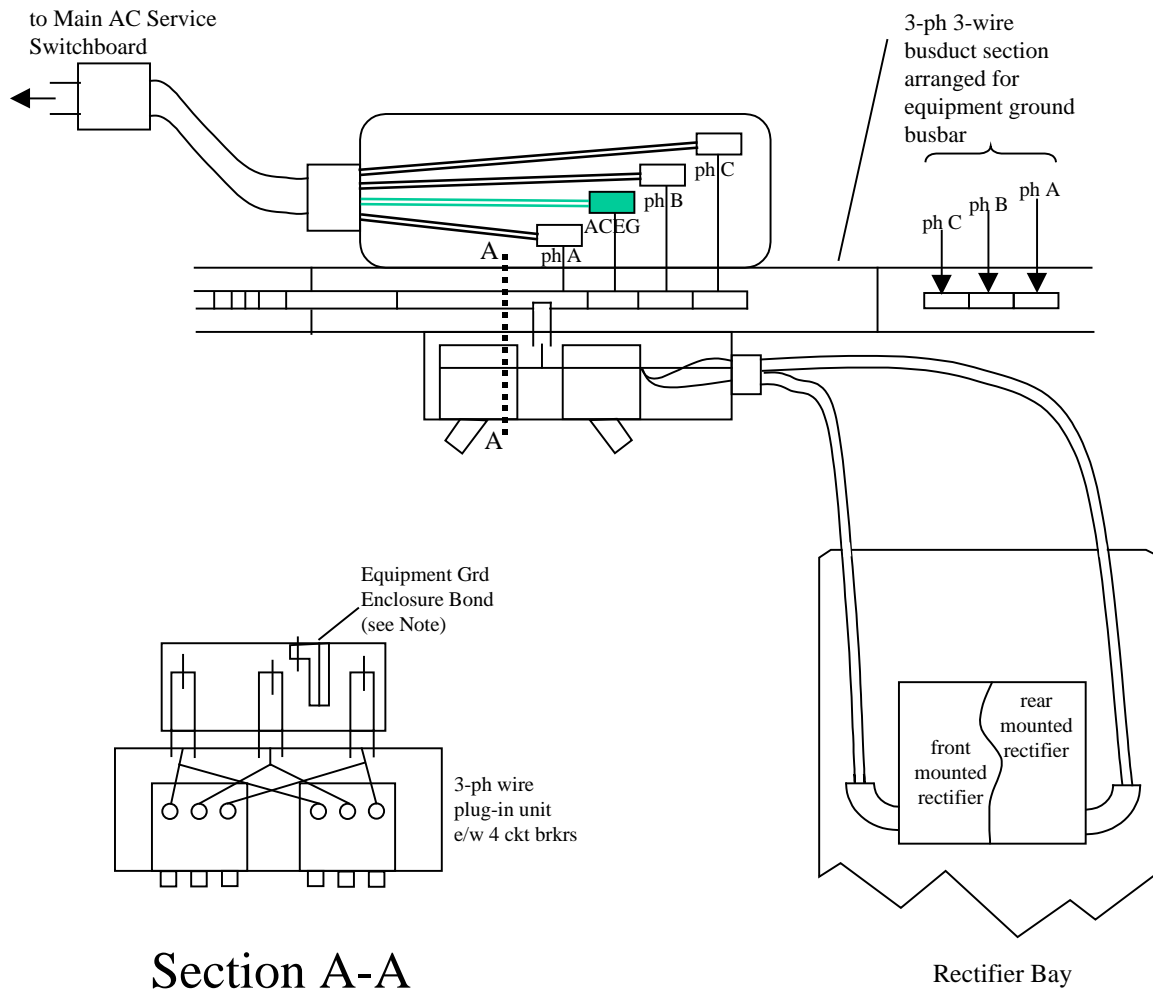

Note: Equipment ground bar-enclosure bond (bus or cable) is required in each busduct section.

Figure 4-15: Typical Busduct System Equipment Grounding Arrangement For a 3-Phase, 3-Wire System

4.16 Cord Connected AC Operated Equipment

Parallel polarized U ground slot receptacles are standard for frame base appliance outlets and other miscellaneous 15 Amp 120V AC branch circuit applications serving cord connected equipment. Such equipment, whether portable or permanently mounted, shall be equipped with a three wire cord and a three wire grounding attachment plug (cap). Two wires of the cord shall serve as circuit conductors. The third wire shall serve as a grounding conductor, connected at the cap to the U blade, and to the equipment structural metal, so that ground continuity is established from the receptacle to the equipment structure.

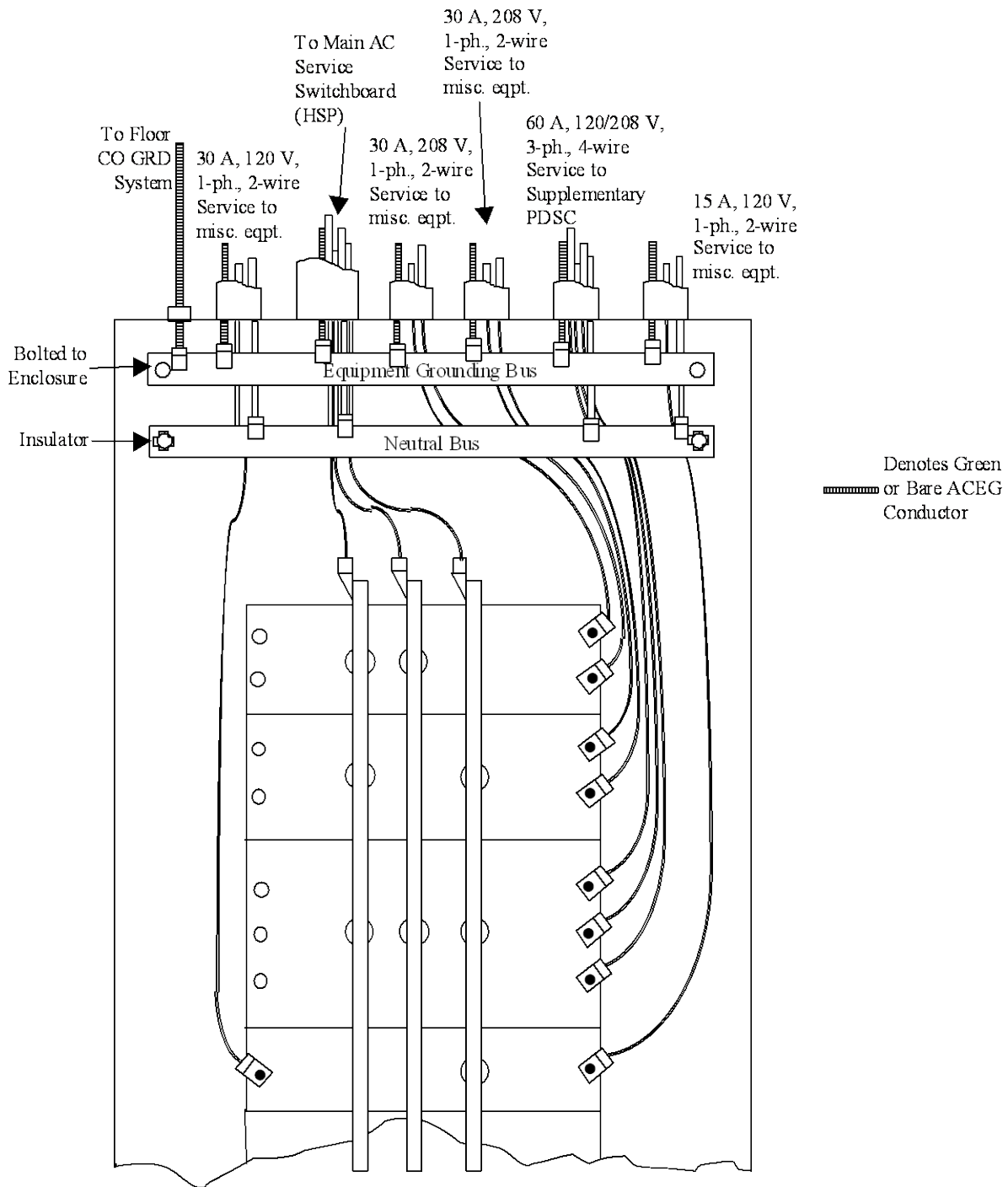

Figure 4-16: Typical Power Distribution Cabinet Equipment Grounding Arrangement

The U ground slots of such receptacles are permanently bonded to the metallic parts utilized for mounting the receptacle to a box or frame, and mounting thereto establishes a ground path to the box or frame metal, a bonding jumper is required. Armored cable, conduit or other raceway metal utilized as enclosures for branch circuit conductors serving the receptacle must be electrically connected/bonded (conduit locknuts or equivalent) to the box or frame.

Permanent cord-connected equipment shall use cords without excessive extra length. Extra length shall not be coiled and stored.

When branch circuit conductors are not run in electrically continuous metallic raceway, an ACEG conductor must be provided from the panelboard to the receptacle. Ground continuity is provided to the U ground slot via the receptacle mounting members (see NEC 250.148). Bonding Jumpers are required.

For branch circuits of other than 120V and/or 15 Amp maximum, suitable receptacles, cord and caps for the required service shall be provided to furnish equivalent grounding facility.

Older central office installations may be equipped with 2-pole, 3-wire grounded receptacles of other designs (e.g., Crowfoot, or other). These receptacles should be replaced with parallel polarized U ground units. Some offices may employ 2-pole, parallel, ungrounded receptacles. These units must be replaced.

Certain portable equipment now in use may be equipped with 2-pole ungrounded caps and 2-wire cords. Unless protected by an approved system of double insulation, such units are potentially hazardous. These cord and caps shall be replaced with 3-wire cords and 2-pole, 3-wire grounded caps.

Generally, all new manufacture AC operated portable or permanently mounted equipment units utilizing cord and cap for AC supply shall be supplied with 3-wire cords and 2-pole, 3-wire grounded caps that function to ground the unit structure. The only exceptions shall be for tools such as soldering irons that must be employed on or near circuit connection points that may have DC potential, where contact with the tool would constitute a short to ground, or for other specialized requirements of similar nature.

AC cord may be used to power equipment within a bay or cabinet but shall not be used for permanent powering of equipment extending out of an enclosure or frame unless it is to a NEMA locking receptacle.

4.17 Frame Base Appliance Outlets

Convenient appliance outlets are provided throughout a communication equipment area to make 120 volt single phase grounded AC service available to operate cord connected appliances (i.e., test sets, soldering irons, floor maintenance equipment, etc.). Appliance outlets are established by mounting duplex parallel polarized U ground slot receptacle units in the base of communication equipment frames, with the U ground slot in contact with the frame metal. Normally (but not always), a base receptacle is provided every third frame. The NEC (see Article 220.14 Exception) does not limit the number of outlets on the circuit for circuits dedicated to these duplex receptacles. However, good engineering practice would limit the outlets to 12 per 20 Amp circuit or 8 per 15 Amp circuit. Although it is not generally recommended to put these outlets on lighting circuits, when this is done, each duplex outlet is computed as a 180 VA load.

The AC circuits are generally extended to the frame area by means of metallic raceway (i.e., conduit, wiremold, etc.). They are alternatively tapped and extended to the ends of frame lines in armored cable or conduit. The metallic raceway is usually terminated in a conduit hole provided in an end guard mounted on an end frame of the frame line, with a fitting approved for use as an equipment grounding fitting (see NEC Article 250.118). When so arranged, equipment ground continuity exists between the unit containing the circuit overcurrent device (usually a 20 Amp circuit breaker mounted in a lighting and appliance branch circuit panelboard) and the frame end guard via the raceway metal and the ACEG conductor. An ACEG conductor must be provided in the raceway and terminated in the box where the raceway terminates.

Usually, the circuit conductors are extended from the raceway terminal point as loose wires routed in end guard and frame bases. They may, however, be extended in the raceway if protection from physical damage or shielding from personnel is desirable. Where gaps occur in the frame line, the portion of the circuit run that bridges the gap must be routed in the raceway terminated at frames with fittings that provide equipment grounding continuity via the raceway between the separated frames.

4.18 Trolley Type Busduct

Trolley type busduct provides 15 Amp 120 V AC power for portable appliances. Generally, installations are made at distributing frames where personnel working on rolling maintenance ladders require a power supply for soldering irons. The busduct consists of a U-shaped steel rail enclosure mounted to superstructure with the mouth of the U facing down. Copper strap conductors are mounted in left and right sides of the U, insulated from the enclosure. Couplings and end connectors are provided to form a continuous circuit that runs the length of the equipment frame line.

The trolley type device, with contacts on either side that maintain sliding contact with the copper straps and four wheels that ride in grooves formed for the purpose in the open side of the enclosure, travels inside the duct and provides a connecting means of extending AC via a three-conductor cable to a receptacle mounted in a conduit box on the rolling ladder. AC service is thereby made available to the trolley duct end closure, through the duct via the trolley and cable.

Other installations are made in equipment aisles, generally in Maintenance Test Centers where rolling ladders are not used. In these applications, the cord is terminated in a parallel-polarized U ground slot plug that hangs within reach above personnel. AC power available therefrom is used to power test sets and various other applications.

Equipment grounding is provided through the AC circuit conduit metal, the duct enclosure metal, metallic parts of the trolley, and the equipment ground conductor provided in the three-conductor cord. An ACEG conductor is required in the conduit that carries branch circuit conductors from the panelboard (or other device) to the busduct end connector.

Prior to the introduction of trolleys, equipment grounding continuity between duct enclosure and cord ACEG conductor depended on contact of duct metal with trolley wheels, which was not always dependable while the trolley was in motion. The latest trolleys provide improved contact by means of spring type contacts. It is recommended that earlier type trolleys be replaced with the spring type contacts.

4.19 Armored Cable

Refer to National Electric Code Article 320 for conductor sizes, quantity, and color normally available. Armored cable (also known as BX cable) containing No. 14 to 1/0 AWG wire contains a bare bonding strap to decrease sheath resistance. This strip shall be cut at the ends of the sheath. It shall never be used as an AC equipment ground conductor. An AC equipment ground conductor is required in all armored cable used for AC distribution, therefore, one additional insulated conductor must be provided. Insulation must be stripped from point of egress from armor or insulation must be colored green for identification. The maximum number of conductors available in an armored cable is limited to three in certain sizes and not more than four. Commercial types of armored cable cannot be used for 3-phase, 4-wire AC circuits requiring an AC equipment ground conductor, or certain single-phase 3-wire circuits (but MC cable can). CenturyLink has a standard that armored power cable shall be no longer than three feet in length, except for vertical runs in manufacturer's equipment. Armored power cable and flexible metal conduit shall never be used in any length in battery rooms per NEC 320.12, and 348.12, but flexible MI or MC (metal-clad) cable can be used in battery rooms. Insulation-coated (liquidtight) armored power cable can be longer than three feet.

CONTENTS

Chapter and Section	Page
5. Integrated Ground Systems.....	5-1
5.1 Integrated Ground Plane	5-1
5.2 Buried Objects.....	5-1
5.3 Frame Grounding Methods.....	5-1
5.4 Integrated Ground Plane Loads.....	5-2
5.4.1 Frame Grounding and Return Bus Reference for DC Power Supplies.....	5-2
5.4.2 Loads Fed from the Principal DC Source	5-3
5.4.3 Loads Fed from Internal Power Sources	5-3
5.5 Grounding for Separately Derived DC and AC Power Supplies	5-3
5.5.1 Referencing Internal DC and AC Power Supplies	5-3
5.5.2 Two or More Power Sources	5-4
5.6 Central Office (CO GRD) System	5-4
5.7 Design Parameters of a COGB	5-5
5.8 Equipment Frame Grounding.....	5-6
5.9 Equipment Frame Busbar Functions as a Combination Discharge-Framework Ground Busbar	5-8
5.10 Relay Rack "Frame Return" Ground Busbars	5-8
5.11 Distributing and Protector Frame Busbars.....	5-8
5.12 Collocated Local Exchange Carrier Grounding	5-9
5.12.1 The Grounding "Feed" for Caged Physical Collocation.....	5-9
5.12.2 Fence Grounding for Caged Physical Collocation	5-10
5.12.3 Isolated Ground Planes in Caged Physical Collocation.....	5-11
5.12.4 Grounding for Other Types of Collocation.....	5-15

Tables

5-1 Minimum and Typical Grounding Electrode Conductors for DC Plants.....	5-2
5-2 Minimum Frame Grounds for DC Plants and Distribution	5-2
5-3 Minimum and Typical Grounding Electrode Conductors for Separately-Derived Sources Fed from a DC Battery Plant	5-4
5-4 DC 0.01 Ohm Resistance Distances at Cable Rack Temperatures	5-5
5-5 Chassis Ground Sizes When Required and Not Specified.....	5-7
5-6 Minimum and Typical Grounding Conductors Run for CLEC Cages	5-10

CONTENTS (Continued)

Figures	Page
5-1 Example of a Possible CLEC Switch Isolated Ground Plane Environment	5-13
5-2 Example of CenturyLink Ground Window Sequencing and Possible Sequencing for a Separate CLEC Ground Window	5-14

5. Integrated Ground Systems

5.1 Integrated Ground Plane

An integrated ground plane (also known as a common bonding network or CBN) is one where the various communication system circuit ground points, and the DC discharge ground (battery return) conductors are not deliberately isolated from framework; and/or the framework is not deliberately isolated from contact via building steel, or other incidental conductive paths, to foreign communication system ground planes or to earth. Current imposed on an integrated plane is free to flow through any member of the plane in seeking a path to earth or to its point of origin in the building.

Miscellaneous metalwork (such as HVAC ducting, chilled water piping, metallic door and window frames, etc.) in a building is generally not required to be intentionally bonded to the integrated ground plane (it is required within the isolated ground plane and for engine room doors and metal near “producers” such as cable vaults and MDF protector frames), except in PANI offices with isolated ground planes for toll equipment (where door frames should be bonded at a minimum). It is often unintentionally bonded. It is becoming more common to intentionally bond HVAC and chilled water systems for building mechanic safety reasons. Where HVAC ducting comes from outside the building (especially if it is continuous metallic structure from the roof, or from outside where the components are not under a lightning zone of protection per NFPA 780), it is desirable to isolate the exterior metal from the interior metal ductwork by use of a fiber-insulating section.

5.2 Buried Objects

Buried fuel tanks, gas piping that has the potential to become energized (see NEC Article 250.104B; although attempts should be made to route electrical and gas piping such that gas piping never needs to be grounded), sewer piping, and other buried objects having entry to the building via metal pipes or other conductive material may act as unintentional earth electrodes. These electrodes shall be made common with the intentional electrode (e.g., ground ring, etc.) by bonding them at their entry point with a No. 2 AWG wire to the OPGPB.

Bond together the telephone cable sheaths that enter the building and connect them to the ground bus on the Main Distributing Frame (MDF) and to the OPGPB (see Figure 6-1). If the MDF and the ground window are on the same floor, bond the ground bus on the MDF to both the CO GRD and the MGB in the ground window.

5.3 Frame Grounding Methods

Multiground the main distribution frame (treat it as an integrated ground plane) for personnel safety. Generally, it is bonded to the cable sheaths, CO GRD, and the ground window main bus (only required to be bonded to MGB when on the same floor).

5.4 Integrated Ground Plane Loads

5.4.1 Frame Grounding and Return Bus Reference for DC Power Supplies

All DC power supplies in the integrated ground plane shall be grounded to the SPGP. The return side (usually the positive bar) of the principal power source shall be grounded with a separate grounding conductor to the site Ground system. Where the power plant is a shared plant serving both isolated and integrated ground planes the grounding conductor is connected to the MGB in the ground window. The principal power source is classified as an external power source. The minimum and typical sizes for the DC Grounding electrode conductor (DCG) that references the return bus of DC plants is given in Table 5-1.

Table 5-1 Minimum and Typical Grounding Electrode Conductors for DC Plants

Power Plant Type	Minimum Grounding Electrode Conductor Size
All	$\leq 0.01 \Omega$
CO Plants > 600 A	750 kcmil
CO Plants ≤ 600 A	1/0 AWG
Radio Sites	#2 AWG (1/0 recommended)
CEV, CEC TM , UE TM , hut	#2 AWG
RT Cabinet	#2 AWG
Commercial Customer Premises	#6 AWG (#2 recommended)

Rectifier, PBD (power distribution bays), and BDFBs should be frame grounded based on the largest protector (DC fuse or breaker) in them (this would also apply to battery stands/trays with disconnect breakers) or feeding them (could be an AC or a DC breaker or fuse). The size of the reference conductor is derived from NEC Table 250.122. The minimum sizes are as shown in Table 5-2.

Table 5-2 Minimum Frame Grounds for DC Plants and Distribution

Maximum Possible Fuse/Breaker Size Feeding To/From/Within Bay/Rack	Minimum Frame Ground Conductor Size
≤ 200 A	#6 AWG
225 - 300 A	#4 AWG
350 - 500 A	#2 AWG
600 - 800 A	1/0 AWG (2/0 if in PANI office)
1,000 A	2/0 AWG
1,200 - 1,600 A	4/0 AWG
un-“fused” battery racks	#6 AWG (#10 if ≤ 13 Ah)

Batteries with disconnects should use the frame ground sizing rules of Table 5-2. But, if the cables to the batteries are "unfused", a simple #6 AWG (or a #10 for 13 Ah and smaller batteries) is provided primarily for static discharge because the frame ground can't be sized large enough to handle the potential short circuit current.

5.4.2 Loads Fed from the Principal DC Source

When integrated ground plane loads are fed from the same principal DC power source that supplies the isolated ground plane, the return conductors shall be routed via the ground window and bonded to the main ground bus in the ground window before they are extended to the equipment being powered.

The frames of all DC-powered equipment shall be bonded as specified principally in this chapter and Chapter 3 for integrated ground plane equipment; and as specified in Chapters 8 and 9 for isolated ground plane equipment. This includes DC lighting. Note, however, that only one DC fixture per circuit needs to be grounded with a #6 AWG because the other fixtures in that circuit are bonded by conduit.

5.4.3 Loads Fed from Internal Power Sources

When integrated ground plane loads are fed from power sources internal to the isolated ground plane, their return conductors shall be routed through and bonded to the MGB within the ground window before they are connected to the power source return bus. (It is generally discouraged to feed integrated ground plane loads from isolated ground plane power sources.)

5.5 Grounding for Separately Derived DC and AC Power Supplies

Frames containing separately derived AC and DC power sources (e.g., transformers, ring plants, and some inverters [see Figures 4-5 and 4-6] and converters) shall be equipped with a frame grounding point that is referenced to the ground via the frame-grounding conductors.

5.5.1 Referencing Internal DC and AC Power Supplies

Separately derived AC and DC power supplies shall be single-point grounded by making a connection from the designated return bus to the nearest COGB/FGB or OPGP / PANI MGB (with the exception of converters and inverters in the isolated ground plane, whose grounded output conductor is tied to the nearest isolated frame or frame ground bar). This grounding reference conductor (grounding electrode conductor) shall not be used to conduct normal load current nor should it be used for frame grounding (see NEC Article 250.121). The grounding location should be at the immediate output of the power supply, and not at the load. Loads shall be powered with separate pairs of conductors and the frames containing the loads shall be grounded. Table 5-3 gives typical minimum grounding electrode conductor sizes for separately-derived sources fed from a DC battery plant.

Table 5-3 Minimum and Typical Grounding Electrode Conductors for Separately-Derived Sources Fed from a DC Battery Plant

Plant Type	Minimum Frame Ground Conductor Size
DC-DC Converters (with output isolated from input)	#6 AWG
Residual Ring Plant	#14 AWG
Inverter(s) \leq 60 kVA without a maintenance bypass	#6 AWG

The residual ring plant grounding electrode conductor sizing is per manufacturer recommendation, and per NEC Articles 250.30A1 Exception 3. NEC Article 250.30A5 Exception 3 even allows a ring plant to not need a grounding electrode conductor if the manufacturer design is proper (non-isolated non-separately-derived) and the manufacturer permits lack of such a conductor. Depending on the types of connectors available on the ring plant output return bus, dual-hole connector requirements for this reference ground may be waived. Inverter ground reference conductor size is based on output conductor(s) size, in accordance with NEC Table 250.66, but with a minimum size of #6 AWG.

5.5.2 Two or More Power Sources

When two or more power sources supply power to circuits that have a common return conductor, there shall be a single-point grounded reference. This shall be accomplished by making a single connection from the common return conductor to the nearest ground reference bus.

Note: The grounded conductor of the input power to a separately derived source shall not be connected to any frame. This violates the single point ground of these power sources.

5.6 Central Office (CO GRD) System

The basis of an integrated ground plane is the CO GRD system. This system starts at the OPGP (see Section 3.5 and Figure 3-7) or PANI MGB, and is extended to the floors via one or more vertical risers (see Section 3.7 and Figures 3-4 and 3-7). The vertical riser connects to the COGB/FGBs (see Sections 3.8 and 5.7, plus Figures 3-4 and 3-7), whose ground potential is extended throughout the floor with horizontal equalizers (see Section 3.8, and Figures 3-5 through 3-7). Main aisle feeders (sized from #2 AWG to 350 kcmil) may branch off from these horizontal equalizers (see Section 3.8, and Figures 3-5 through 3-7). Individual aisle stringers are typically #2 AWG, and the individual relay racks bond to these stringers are usually #6 AWG (see Sections 3.8, 5.8, 5.10, and 9.1; as well as Figures 3-5 through 3-7). When adding a new aisle/lineup or adding to an existing one with no overhead stringer, typically the Engineer should extend the stringer for the entire aisle length to avoid excessive future ground splices.

Ultimately it is most desirable to keep impedance as low as possible among internal grounding cables to facilitate the flow of electrons back to ground and limit voltage differentials during a lightning strike or power fault to ground. The desirable limit for any internal grounding path back to the building SPGP is 0.03 DC ohms (up to 0.01 ohms on any one branch). Table 5-4 gives the approximate 0.01 DC ohm limit at expected cable rack temperatures for the given typical grounding cable sizes.

Table 5-4 DC 0.01 Ohm Resistance Distances at Cable Rack Temperatures

Grounding Cable Size	0.01 Ω DC Resistance Distance
#6 AWG	25 ft
#2 AWG	60 ft
1/0 AWG	90 ft
2/0 AWG	120 ft
4/0 AWG	190 ft
350 kcmil	300 ft
750 kcmil	650 ft

Some other standards (such as ATIS-0600333) require certain grounding conductors to have 2000 circular mils of cable size per linear foot. This corresponds to approximately a resistance of 0.005 DC ohms (half the distances shown in the table above), which is also the resistance required for certain key grounding conductors in RUS standards.

5.7 Design Parameters of a COGB

The CO GRD bars are used to facilitate distribution of horizontal ground conductors on various floors of a CO. The bars are generally mounted on a building column. If the CO GRD busbars are wall-mounted, try to use an internal wall instead of an external wall or column, since lightning will hit the outside of a building. The busbars don't need to be insulated from the column (they do need to be insulated from cable racks, if they are attached to those), but they do need to be kept a minimum of 3" from the surface to allow for workspace. If the main COGB(s) for this floor (not including supplemental COGBs on this floor fed from this main bar or the same vertical riser; but including COGBs on the floor fed from a different vertical riser) is insulated from building steel/concrete, it must be bonded (with a minimum #6 AWG) to accessible building steel (can be rebar or concrete or I-beams, etc.), and water piping on that floor (this requirement is per NEC Articles 250.30A4 250.104B, and 250.52A1 and A2). Preferably, place the COGBs so that the grounding conductors coming from the equipment on the floor may terminate opposite from the vertical riser connection. Ground is established by bonding the busbars to the vertical riser.

The floor COGBs are made of copper and are usually at least ¼" wide, 4" high and 16-24" long. Aluminum buses in DC ground systems are prohibited (except where they are pre-existing). All connections to the COGB shall be with 2-hole crimp connectors.

Each COGB or OPGP should be pre-drilled with a minimum of 16 sets of holes on 1" centers, and 6 sets of holes on 5/8" centers (floors with more equipment may require larger bars and more holes). Drilling of existing bars is not recommended, and if done, must have the written permission of the Design Engineer, protection for nearby equipment and buses, and must be done in the Maintenance Window.

5.8 Equipment Frame Grounding

All switch frames, fuse bays, relay racks, miscellaneous bays, and cabinets (including PICS storage) shall be grounded with a minimum #6 AWG (bays that have no power running to them, no metallic cables in them, nor any circuit packs in them, and that are not within 6 feet of an isolated ground plane, are not required to be grounded) from the DC grounding system (DCEG). Normally, a #2 insulated stranded wire is run on top of the lineup, with #6 branches to ground individual frames (this is sometimes referred to as a Telecommunications Equipment Bonding Conductor, TEBC). All painted contact surfaces shall be cleaned so that metal-metal contact is made. A non-oxidizing agent shall be applied to inhibit corrosion. The connection to the frame shall be made with a two-hole copper crimp connector. Connections to grounding conductors should be made so that the conductor flows toward the ground source. In the past, a steel pipe used to support the bay framework was used as a frame ground. This support pipe is no longer acceptable for grounding newly added frames on a going forward basis.

There are some guidelines (more can be found in Tech Pub 77350 and Telcordia NEBS GR-1089) to follow for grounding individual shelves within a relay rack (chassis grounding). Terminating a lug on top of another one on the same side of a frame or bus bar (known as "double-lugging") is prohibited. Internal wiring grounding conductors should be bare or have green insulation; although this is not absolutely required. Shelf chassis grounding can be done with ground wires to the relay rack (sometimes referred to as a Unit Bonding Conductor or UBC) or with self-tapping shelf mounting screws that strip paint from the threads). The manufacturer should specify the wire size and type. The screws must also use a toothed lock washer. Resistance between chassis and frame ground must measure less than 0.01 ohms (0.001 ohms for NNS). If this requirement is not met, paint must be scraped, or direct wires run, or larger conductors used. Single-hole grounding lugs are allowed for shelf/chassis grounds. If the shelf provides a two-hole connection, use it; otherwise a one-hole lug is sufficient for both the chassis and frame connections. Lacking manufacturer guidelines, the intent of NEC Table 250.122 should be followed. In other words, the minimum copper wire sizes (or equivalent diameter screws) shown in Table 5-5 apply.

Table 5-5 Chassis Ground Sizes When Required and Not Specified

Feeding Fuse/Breaker Size	Minimum Chassis Ground Wire Size
≤ 4 A	19 AWG
5 A	18 AWG
6 - 10 A	16 AWG
12 - 15 A	14 AWG
20 A	12 AWG
25 - 60 A	10 AWG
70 - 100 A	8 AWG
110 - 200 A	6 AWG
225-300 A	4 AWG

Certain older switching systems; and various other older equipment frames are equipped with frame ground busbars. These ground bars are mounted in electrical contact with the frame metal. These ground bars thereby form a part of an integrated (or isolated in the case of the Ericsson switch) ground plane in common with frame metal and any other metallic components that are electrically bonded. The integrated ground plane for these types of toll transport systems is a single plane extending throughout the building with multiple points of interface between building and discharge ground system through the equipment frame ground bars. More information is contained the sections 5.9 and 5.10 on these and similar types of systems.

Frame ground bars, when provided, normally function as a common ground point for circuit ground conductors from equipment units mounted on the frame. The ground current must return to the DC plant batteries. A current return path, dependent on the ground system design of individual communication systems, may be afforded by:

- Discharge ground conductors run from individual frames.
- Interjunctioning ground bars in a frame line into a common conductor, and extending the run with wire to discharge ground paths that ultimately terminate at the ground terminal of the battery.
- Various combinations of the methods just mentioned.

5.9 Equipment Frame Busbar Functions as a Combination Discharge-Framework Ground Busbar

Ground busbars that mount directly on framework may function as combination paths for current return to battery and for framework grounding. Most modern equipment does not use this method for ground and battery return; however, its use in existing installed equipment is not totally obsolete. Equipment units mounted on frames sometimes were circuit-grounded at frame ground busbars in electrical contact with frame metal. Busbars mounted in a frame lineup were junctioned to form a continuous conductive path. The continuous run was connected at the head of the lineup to a main aisle ground equalizer extending along the main aisle to allow connection thereto from each lineup in the system. This equalizer is connected to the discharge ground conductor of the battery discharge circuit feeding the system to provide a current return path and to the floor CO GRD system to safety-ground the frames. This arrangement (including the frame busbars, aka Equipment Frame or Relay Rack Ground Busbars) is referred to as a Combination Discharge-Framework Ground System. These systems use standard frame and aisle stringer cable sizes, as per Section 5.8, and Figure 3-6.

5.10 Relay Rack "Frame Return" Ground Busbars

The term "RR GRD", is used extensively on some older communication systems circuit schematic drawings to denote that equipment units mounted on an equipment frame should be circuit grounded to the frame ground bar (these systems' only return path is through this framework return system). This system requires a 750 kcmil main aisle equalizer with connecting 350 kcmil aisle equalizers (however, the individual bay connections need be no larger than the traditional #6 AWG). Reference to a Relay Rack Ground busbar may be construed to mean an Equipment Frame Ground busbar as described in paragraph 5.9. However, in modern communication systems, "Relay Rack" is no longer used as a generic term to denote frames.

5.11 Distributing and Protector Frame Busbars

Protector frames come with ground bars to provide a direct path to ground for high potential energy intercepted from cables entering the office through the CEF. Protectors may be mounted on an individual framework in proximity to a distributing frame or may be mounted on a distributing frame. A protector ground bar is normally mounted at the top of the frame, fastened to each protector mounting support. A frame ground bar is furnished near the bottom of protector frames or distributing frames mounting protectors. An insulated stranded 1/0 AWG (2/0 AWG in PANI sites) conductor bonds the upper and lower bars. The lower bar functions as a FRWK GRD, a grounding point for cable sheaths and for miscellaneous ground connections. A 1/0 AWG is extended from this bar to the COGB/OPGP (or 2/0 to the PANI MGB/FGB) on the same floor. In addition, a 1/0 AWG (2/0 in PANI sites) ground conductor is extended from this point to the cable vault for bonding to the cable sheaths.

Miscellaneous metal within 6' of a protector frame should be grounded. In a PANI office, there should be separate leads for the protector frame ground (going to the P section), and the nearby miscellaneous metal (going to the N section).

When the protector frame is located on the same floor as an isolated-integrated ground window, an insulated stranded No. 1/0 AWG conductor bonds from the integrated side of the MGB in the ground window to the main ground bar of the frame (lower bar). The No. 1/0 AWG ground conductors serve as a discharge ground path for lightning currents, as a voltage equalizer, and as a frame ground.

Cosmic® type distributing frames (single or double sided) are designed to be grounded with a No. 6 AWG or larger from each frame to a 1/0 AWG (or to the bare # 6 AWG that comes as part of the frame - which is then tapped to a 1/0 AWG) to the CO Ground bar (or OPGP, whichever is closer and more convenient), and to the ground window if the distributing frame and ground window are both located on the same floor.

Intermediate Distributing Frames (including ICDF frames) that don't tie to OSP metallic cables may be simply grounded to the integrated CO grounding system with #6 AWG.

Main and Cosmic® Distributing Frame and Protector Frame Grounds must use their own unique (separate from the rest of the integrated ground plane) grounding leads run directly to the COGB (see Figure 3-6). Only the protector frame (not other distributing frame types) is required to have a 1/0 run to the CEF, and a 1/0 run to the ground window (when located on the same floor).

5.12 Collocated Local Exchange Carrier Grounding

CenturyLink offers several different types of collocation in its COs. There is physical collocation, shared collocation, virtual collocation, and common or cageless physical collocation. Any of these may be requested by a given CLEC (Competitive Local Exchange Carrier).

Besides this document, CenturyLink Technical Publication 77350 contains further references to grounding installation, both for CenturyLink and CLEC equipment. Note that CLECs are not held to more stringent grounding standards than those to which CenturyLink holds itself.

5.12.1 The Grounding "Feed" for Caged Physical Collocation

The type of collocation typically chosen by larger CLECs (i.e., those who want to install more than one or two frames of equipment) is caged physical collocation. In caged physical collocation, the collocater's space is physically separated from that of CenturyLink by fences, walls, or other barriers. The CLEC installs, monitors, and maintains its own equipment, while CenturyLink provides common items such as power, grounding, HVAC, and sometimes an interface point known as the Single Point of Termination or Interconnection Distributing Frame (ICDF), etc.

For these physical collocators, CenturyLink’s grounding interface to them is essentially an extension of the nearest COGB. The COGB is extended with the equivalent of a horizontal equalizer to a CLGB (Collocated Local Ground Bar). The CLEC is then free to use this CLGB similarly to a COGB/FGB/MGB for grounding their equipment frames.

The size of the grounding conductor from the COGB/FGB or OPGP / PANI MGB to the CLGB (the CLGB is located inside each CLEC area) is summarized in Table 5-6.

Table 5-6 Minimum and Typical Grounding Conductors Run for CLEC Cages

Cage Type and Distance from CenturyLink Ground Bar	Minimum Grounding Conductor Size
All	$\leq 0.01 \Omega$
Cage $\leq 100 \text{ ft}^2$, and cable run $\leq 75 \text{ ft}$	1/0 AWG (2/0 for PANI sites)
100 $\text{ft}^2 >$ Cage $< 500 \text{ ft}^2$, or cable run is $> 75 \text{ ft}$	4/0 AWG
Cage $\geq 500 \text{ ft}^2$	750 kcmil
Multiple Cages	750 kcmil with individual drops
Cages containing equipment with ground-bonded returns	750 kcmil

As a general rule, one of CenturyLink’s existing horizontal equalizers should not be used for CLEC cages, nor should CenturyLink connect its equipment to a caged CLEC ground “feeder”.

Collocators are generally prohibited from using frames as a battery return path. However, if their equipment uses this method, CenturyLink must be informed up front in order to properly size grounding conductors. In those cases, the ground cable “feeding” them has to be upsized, as shown in Table 5-6.

5.12.2 Fence Grounding for Caged Physical Collocation

Most physical CLEC areas (as well as some CenturyLink subsidiaries) use chain link fence as the barrier between CenturyLink and the CLEC. All fence sections and hardware must have bonding continuity. Fence hardware can be used to meet this function. If the door or gate is metallic, it too shall be bonded to the adjacent metallic wall or fence with a flexible bonding conductor. In some cases, the fence sections and the door/gate are bonded together with clips attached to an incidental bonding conductor run along the top of the fence. Because it is an incidental bonding conductor, it is treated similarly to rack connection hardware and is not subject to most of the requirements of this publication.

Requirements for Cages Without a Fence Top Incidental Bonding Conductor

This fencing shall be bonded to the CLGB from two locations at opposite corners, whenever three or four chain link or other metallic walls are used (one bond can be used if only one or two of the walls are chain link or other metallic structure). This connection shall be made with a minimum No. 6 stranded “green-wire” copper conductor. The CLGB connections to bare fencing shall be made with a two-hole crimp-type copper lug (if connected to the incidental fence bonding conductor described below, the # 6 green wire can be connected with an H-tap), which is sized properly for the connection point. This connection shall be cleaned and treated with an anti-corrosion inhibitor. However, fence hardware bonding connections are considered incidental bonds and are not subject to the same crimping and anti-corrosion requirements as Central Office Ground System connections.

Requirements for Cages With a Fence Top Incidental Bonding Conductor

When this is done, only one No. 6 AWG conductor need be run from the fence top incidental bonding conductor, connected with an H-tap, to the CLGB. If a chain link wall is shared by more than one collocater, there may be attachments to that section from all CLGBs in cages which share the wall, or other “walls” (besides the shared fencing) can be chosen for the required #6 AWG green wire connection(s) from the CLGBs.

5.12.3 Isolated Ground Planes in Caged Physical Collocation

Most CLECs do not desire (and CenturyLink and Regulatory bodies generally prohibit it) to place Class 5 end office switching equipment in their physically collocated space. In some rare cases this has occurred. When it does occur, or if there is other CLEC equipment requiring an isolated ground plane, this equipment is restricted to physically separated collocation – i.e., it will not be allowed for virtual collocation or cageless physical collocation within our lineups if it requires an isolated ground plane. Not all “switches” require isolated grounding. If the CLEC’s “switch” doesn’t require isolated grounding, connections are made to the CLGB just as with any other type of integrated ground plane equipment.

When an isolated ground plane switch is placed in caged physical collocation, the cage fencing or walls provide a needed physical separation for the isolated ground plane. However, when an isolated ground plane switch is placed in a cageless environment, a 6 foot separation from all other office equipment, physically marked on the floor, must be maintained.

When a physical collocator places a switch in their area which requires an isolated ground plane, they should follow the general rules laid out in Chapter 8 of this document. However, CenturyLink will not mandate what grounding rules a CLEC follows internal to its own equipment, but is concerned about the interface between the CenturyLink grounding system and that of the CLEC. CenturyLink will not allow direct connections to its own ground windows by CLECs except in extenuating circumstances, evaluated on a case-by-case basis through the Bona Fide Request (BFR) process.

As mentioned, CenturyLink will not dictate how the CLEC establishes an isolated ground plane, but using the principles defined in Chapter 8, a couple of suggestions can be made. Essentially, CenturyLink uses two types of Ground Windows (MGBs): those physically separated from the power plant or power source (separate ground window) and those that are the return bus bar of the power source (using a return bus as the ground window). These types of setups are detailed in Figures 8-6 through 8-10. The CLEC is free to do essentially the same.

Although the CLEC does not place their own power plant, CLECs large enough to place isolated ground plane switching equipment will typically have a large BDFB or other type of Power Distribution Board to which CenturyLink will provide power. The CLEC may use the return bar of this “BDFB” as a ground window, following the guidelines of Chapter 8 (Figures 8-9 and 8-10 are especially helpful). The BDFB return bar separation point for the isolated and integrated sides would be the point on the bar where the CLGB connection is made.

As an alternative, the CLEC may choose to set up a separate ground window. Figures 5-1 and 5-2 illustrate this separate ground window concept. In these figures, the CLEC’s separate ground window bar is referred to as a CMGB (Collocator’s Main Ground Bus). This setup follows the general principles represented in Figures 8-6 through 8-8.

As noted in Chapter 8, and in Figure 5-2, integrated ground plane metallic objects (frames, ironwork, etc.) that are located within six feet of an isolated ground plane must be “foreign-object” grounded back to the integrated side of their “ground window”. This includes any chain-link fencing.

Physical collocators who place isolated ground plane equipment should be served with a 750 kcmil COGB to CLGB equalizer, even if they are “cageless physical” CLECs that wouldn’t even normally require a CLGB.

Note that when a CLEC is fed directly from a DC power plant PBD (regardless of whether they have isolated or integrated equipment), and that power plant has a remote ground window, the return conductor serving the CLEC must be run through the ground window and bonded to its MGB.

Qwest Area

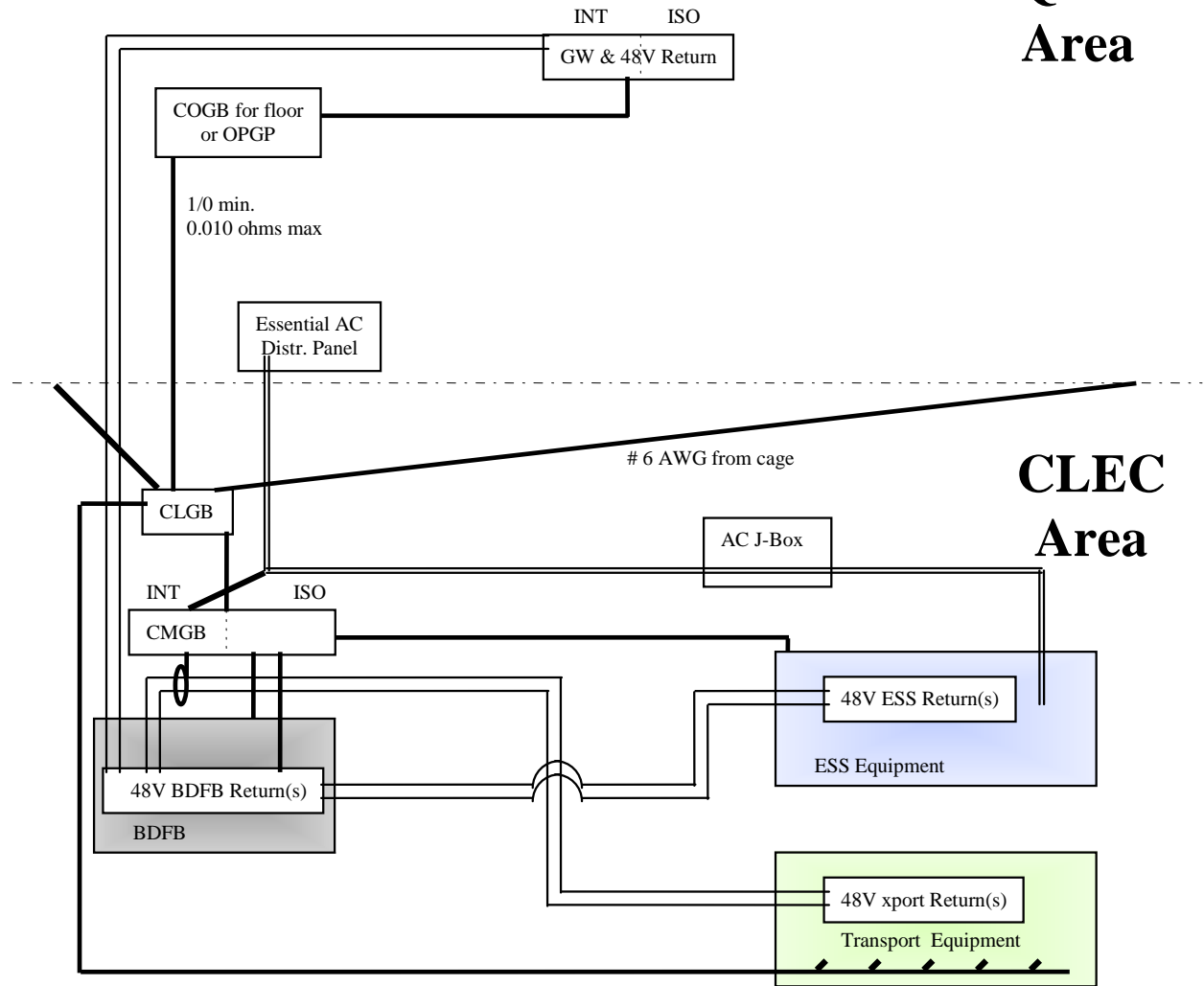

LEGEND

-  Grounding Leads
-  Grounded A & B Battery Return Leads (Paired with -48V Feeds)
-  AC Feeds

Figure 5-1: Example of a Possible CLEC Switch Isolated Ground Plane Environment

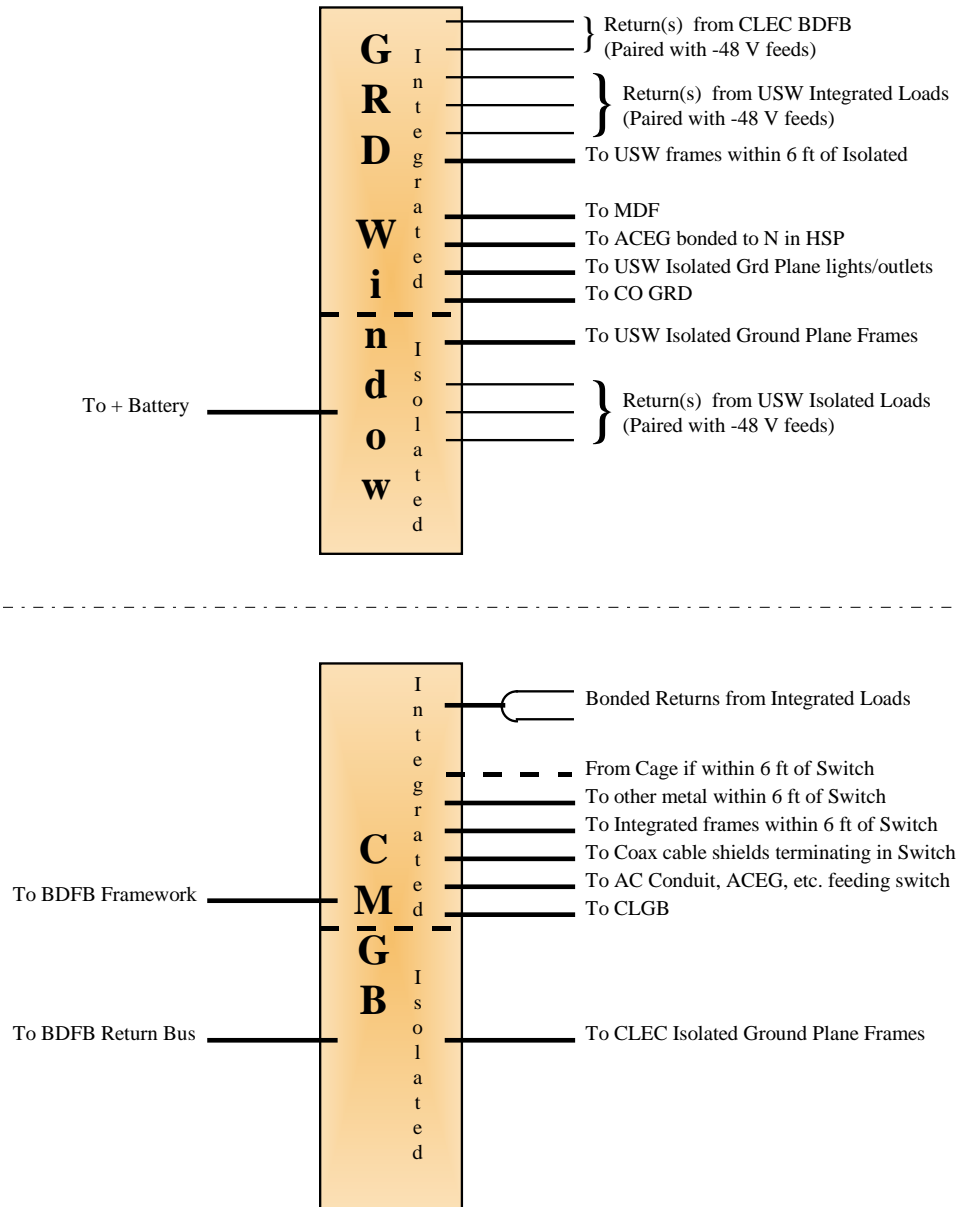

Figure 5-2: Example of CenturyLink Ground Window Sequencing and Possible Sequencing for a Separate CLEC Ground Window

5.12.4 Grounding for Other Types of Collocation

There are several other types of collocation offered by CenturyLink. In virtual collocation, the CLEC pays CenturyLink to buy, install, monitor, and maintain equipment. This equipment is placed in CenturyLink lineups, and treated just like CenturyLink's own equipment. It is grounded in the same way as any other CenturyLink integrated ground plane frame in that lineup. This is typically done with a No. 6 AWG bonded to the framework and then connected to a No. 2 AWG "stringer" which runs down the lineup. The stringer runs back towards the COGB (possibly connecting to a horizontal equalizer extended from the COGB).

Another type of collocation is known as cageless physical, or common collocation. This is similar to virtual collocation in that it is sold on a bay-by-bay basis, and is often in existing CenturyLink lineups, next to CenturyLink frames. But, like physical collocation, the equipment is bought, installed, monitored, and maintained by the CLEC. Because the equipment is often in CenturyLink lineups, it is grounded and installed to quality standards mentioned in this Publication and in Tech Pub 77350, in the same way as the aforementioned virtual collocation.

Another type of collocation offered by CenturyLink is known as shared collocation or shared physical space collocation. This is a type of physical collocation where an area of floor space is given to a group of collocators (typically 2 to 4 of them). They may or may not be physically separated from each other (those that are physically separated are known as "shared physical space collocation, and those that aren't separated are termed "shared collocation", or from CenturyLink, by a cage, wall, or other barrier. If it is separated by a cage or other barrier, the caged physical collocation rules given previously apply. For shared collocators not separated by a physical barrier, if the shared collocation area is physically separated from CenturyLink lineups by 6 feet or more, then the shared area will be served by a single CLGB (shared by all CLECs in that shared area). In these cases, the COGB to CLGB feeder is sized in accordance with the rules given previously. However, if the shared uncaged area is not separated from CenturyLink lineups by at least 6 feet, then the CLEC frames are treated like those of virtual or cageless physical collocators, as far as grounding and quality standards are concerned.

Finally, wireless collocation is available. Grounding requirements for wireless collocations are found in Section 7.23.

CONTENTS

Chapter and Section	Page
6. Cable Entrance Facility (CEF).....	6-1
6.1 Determining Exposure to Foreign Potentials.....	6-1
6.2 Central Office Protection.....	6-1
6.3 CEF Protection Measures (Bonding and Grounding).....	6-2
6.4 Alternative Arrangements for Bonding and Grounding Optical Fiber Cables.....	6-3
6.5 Location of the CEF.....	6-4
6.6 Air Dryer Grounding.....	6-5

Figures

6-1 Underground CO Entrance with Exposed Entrance Cable for Traditional Isolated-Integrated Offices	6-5
6-2 Underground CO Entrance Cable Incorporating an Insulating Joint	6-6
6-3 Bonding and Grounding of Optical Fiber Cable in Interconnect Equipment.....	6-7

6 Cable Entrance Facility (CEF)

6.1 Determining Exposure to Foreign Potentials

Depending on its environment, outside plant cables may be subjected to the following sources or potentials, either singly or in combinations:

- Lightning
- Power Contacts
- Power Induction
- Ground Potential Rise

Exposed vs. Unexposed Plant – The terms exposed and unexposed are used to classify the plant with respect to its vulnerability to these sources of current and voltage. Outside plant that is subject to electrical disturbances from any of these sources is classified as exposed. Plant not subject to their effect is classified as unexposed. The exposed classification of outside plant is a function not only of the outside plant environment, but also of the physical characteristics of the plant. For example, a conventional shielded, paired conductor cable subject to the electrical disturbances detailed above would be classified as exposed. An all-dielectric optical fiber cable placed in the same environment would be classified as unexposed because the optical fiber cable contains no metallic sheath components, metallic strength members or metallic pairs. (See the National Electrical Safety Code [NESC] for further detail.)

6.2 Central Office Protection

All telecommunications cables that contain metallic components such as a metallic shield, a metallic strength member, metallic pairs or a vapor barrier, require some form of electrical protection at the central office. The electrical protection includes bonding and grounding of cable metallic sheath components and metallic strength members, and the application of protectors to metallic pairs, along with fuse links and heat coils, where required. Air pressure pipe that is exposed and is metallic or contains a metallic vapor barrier also requires bonding and grounding. Where the cable complement consists of both exposed and unexposed cables, it is advisable to provide protective devices on metallic pairs on both the exposed and unexposed cables for ease of administration and the possibility of future rearrangements. Cables containing no metal components, such as all-dielectric optical fiber cables without metallic pairs, are considered unexposed and will not require electrical protection at the central office.

Generally, "exposed" cables enter through the CEF (where their shields and/or metallic strength members are bonded), and then are routed directly to an MDF or COSMIC protector frame. Routing of "exposed" cables before they reach a protector frame cannot be with internal building "unexposed" metallic voice and data cables. Note that in Customer Premises buildings, the CEF may be called the TEF.

In order to minimize exposure of the network equipment to lightning in CenturyLink buildings, entrance of any metallic member from the outside of the building must enter through one of the following three entrances so that it can be easily protected and bonded to ground: CEF, AC service entrance, or waveguide hatchplate.

6.3 CEF Protection Measures (Bonding and Grounding)

The OPGPB (or PANI MGB) is the CO location for grounding conductor connection to earth electrodes. The major emphasis of bonding and grounding is to equalize potentials between equipment ground, power ground, metal cable components, MDF ground, and the site principal ground point. The metallic sheath components and metallic strength members of all cables entering the central office must be connected to the site ground as close to the entrance as possible but not more than 50 feet after entering the building structure. A minimum 1/0 or 2/0 ground conductor (maximum of 0.01 Ω – see section 5.6) shall be run from the OPGPB (PANI MGB) to each cable entrance. In addition, a 1/0 AWG shall be run from the CEF to the protector frame. Insulating joints may be required in certain areas, as designated by the CenturyLink Electrical Protection Engineer, where corrosion of cable or potential high voltage DC faults are a problem. Insulating joints do not provide good personnel protection against hazardous voltages and aren't intended for that purpose (see Figure 6-2). Because the cable entrance is a place where lightning can enter the building, all metal in the cable entrance facility should be grounded (in a PANI office, the CEGB is run to the P section, and the cable entrance miscellaneous metal is run to the N section).

Central Office Without Insulating Joints

In a CO without insulating joints, bond metal strength members and shields of entrance cables with #6 or bonding ribbon to the ground bar (or 1/0 or larger wire) which is run from the CEF to the OPGPB (if a CEGB isolated from the vault wall is used, a #2 stringer can be run from it to ring the vault, unless multiple duct banks are daisy-chained, in which case the ground "feeder" back to the CEGB should be 1/0 or larger). The routing of the 1/0 or larger cable to the OPGP (or PANI MGB) shall be as direct as possible and routed away from equipment that might be affected by surges. Figure 6-1 shows CO entrance cables without insulating joints. Often, the bonding is done at CEF splice cases. In addition to bonding to the CEF ground system at the splice, the shield is usually bonded across the splice (usually a direct bond, or bonds from the cable entrance ground system to the shields on both sides of the splice; except for capacitive insulating joints) in traditional Bell System isolated-integrated offices (known in ANSI/ATIS 0600313.2008 as a "traditional entrance"; but not bonded (the TIP cable shields are only bonded at the MDF) in traditional PANI offices, with a minimum 3" separation between the bonded and unbonded shields (preferably with the TIP cable shields tape-isolated). This latter configuration is described in ANSI/ATIS 0600313.2008 as an "isolated entrance".

Central Office With Insulating Joints

Figure 6-2 shows an entrance cable with an insulating joint. Insulating joints are rare (except where "light rail" cable exposure exists in traditional Bell System isolated-integrated offices); however, where they exist:

- The metal sheath components and strength members of all entering cables must be bonded together with #6 or bonding ribbon on the OSP side of the insulating joint within the first utility hole adjacent to the office (MH-0). The cables, together with all associated metal (such as capacitors, pressure pipes, and bonding wire or ribbon), must be isolated from all grounded objects (such as building steel, equipment and racks) on the outside plant side of the insulating joint.
- The insulating joint must be as near as possible to the point of entrance. Insulating joints must be capacitor-bridged – see Figure 6-2 (this capacitor is usually about 1,000 microFarads for single cables; and 10,000 microFarads if it serves more cables).

All "exposed" metallic conductors (excluding waveguides – which include coaxial cables – whose bonding requirements are found in Chapter 7) must enter the CO through the CEF, and be bonded and grounded as specified in the preceding paragraphs.

Bonding and cable continuity in the CEF can be verified using a CORM (see Telcordia BR 802-010-100 for proper application).

6.4 Alternative Arrangements for Bonding and Grounding Optical Fiber Cables

There may be operational or economic liabilities associated with CEF grounding and bonding of optical fiber cable metallic sheath components and strength members. For example, access to these components may require a fiber splice (preferably to a cable that has no shield or metallic strength member so that there is no possibility of carrying lightning further into the building). Grounding and bonding metallic sheath components and strength members at the interconnection equipment would overcome these liabilities, but would allow lightning and power fault currents to be carried past the CEF and into the central office. Although bonding and grounding of all metallic sheath components and strength members at the CEF is recommended, the methods described in the succeeding three paragraphs offer adequate protection.

If the outermost metal on a fiber cable is a full circumferential shield(s), only this shield may be grounded at the CEF. All metal components internal to the this shield may not be bonded at the CEF, but, if electrically continuous, should be bonded together and grounded at the interconnection equipment. Extensions of outside plant optical fiber cable into the central office should conform to fire protection requirements (NEC Article 800.48 allows unListed cable to extend no more than 50 feet into the building; however, going forward unlisted OSP cable in the CO that is not in a cable vault needs to be covered with fire-retardant tape). Where insulating joints are used at the central office, this method should not be used as it will short circuit the insulating joint.

Bonding and grounding may be done only at the interconnection equipment when there are compelling reasons for not bonding and grounding all metallic components in the CEF. The pathway within the central office through which the outside plant optical fiber cable is routed should conform to fire protection requirements (see NEC Articles 770 and 800).

All metallic sheath components and strength members, as well as the interconnection equipment itself, must be bonded and grounded to the building ground system. A 6 AWG copper wire or equivalent should be used. If there is more than one cable, the 6 AWG wires should be joined to a 1/0 copper conductor running to the CO GRD system. The routing of this conductor should be as direct and straight as possible, and away from equipment that might be affected by flashover from the conductor. The bonding and grounding of a single optical fiber cable containing a shield and central metallic strength member is illustrated in Figure 6-3. Where insulating joints are used in the central office, the metallic components must be separated from the central office building system ground through a capacitor as shown in Figure 6-2.

6.5 Location of the CEF

In accordance with NEC 800.100A4, the CEF should be within 20' of the building AC HSP. Exceptions are allowed when this is not practical (such as larger buildings).

Often the CEF is under the building or in a separate room on the lowest floor (both are a cable vault). In small structures, it may be a space on the wall (preferably with the non-fire-retardant cable in a fire-resistant box enclosure); and in a few sites it is a pedestal (14" wide or larger) with a copper ground bar (as opposed to steel) just outside the building wall. If this pedestal is metallic, its internal ground bar (the CEGB) should be bonded to this metal. If the CEF pedestal (when used) isn't within 6' of the COGF, drive a 5/8" x 8' minimum ground rod and bond it to the COGF with a tinned solid #2 copper conductor; otherwise bond the CEGB bar of the pedestal to the COGF with the solid #2 conductor. (If the COGF is not readily accessible, bond the pedestal CEGB to the PANI MGB "P" section, entering the building at a point close to the PANI MGB.

6.6 Air Dryer Grounding

There are typically air dryer(s) and an air pressurization system near the CEF for non-gel-filled and/or non-PIC cables. The process of dessicating the air prior to cable pressurization builds up static on the air dryers and metallic components of the air pressure system. Because of this, it is recommended not to place the air dryer in the engine room. It is common practice to ground the air dryer(s), manifold, and air pressurization monitoring system to the DC grounding system (regardless of any ACEG grounds that may exist) with a minimum 6 AWG, green-insulated, stranded conductor, connected to the nearest CO GRD system cable or bar. Air dryers for waveguide and microwave horns must be grounded in a similar manner.

PICs storage cabinets in the air dryer room, and any metallic objects with metallic exposure or metallic connections to outside the building should also be grounded, as detailed elsewhere in this document. Air dryers not located in a CO shall also be grounded (including metallic housings), and should be separated from static-sensitive electronics.

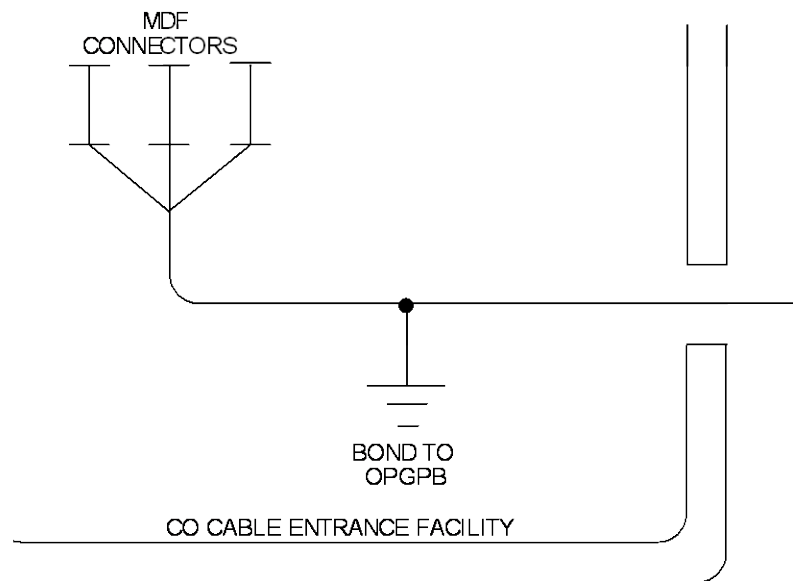

Figure 6-1: Underground CO Entrance with Exposed Entrance Cable for Traditional Isolated-Integrated Offices

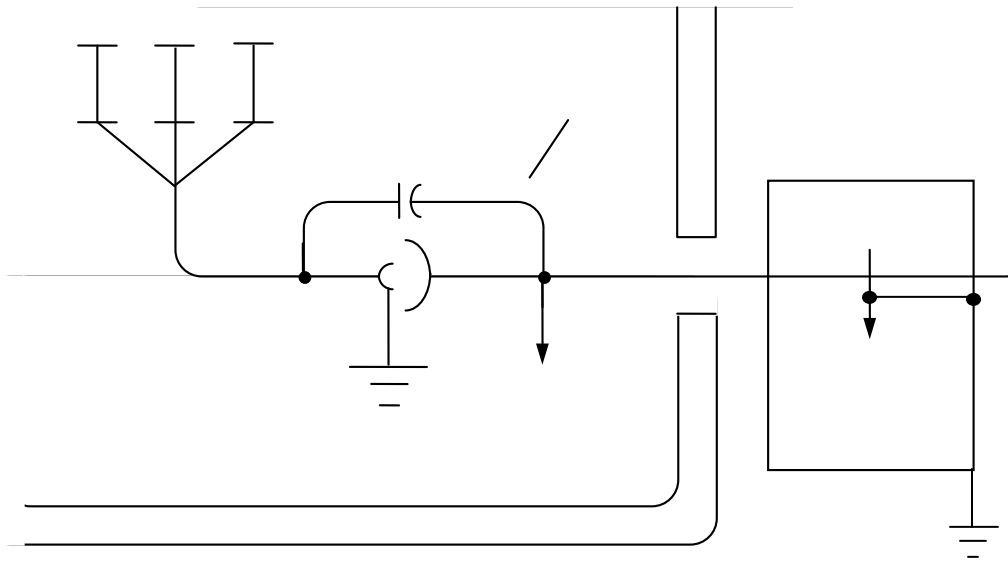
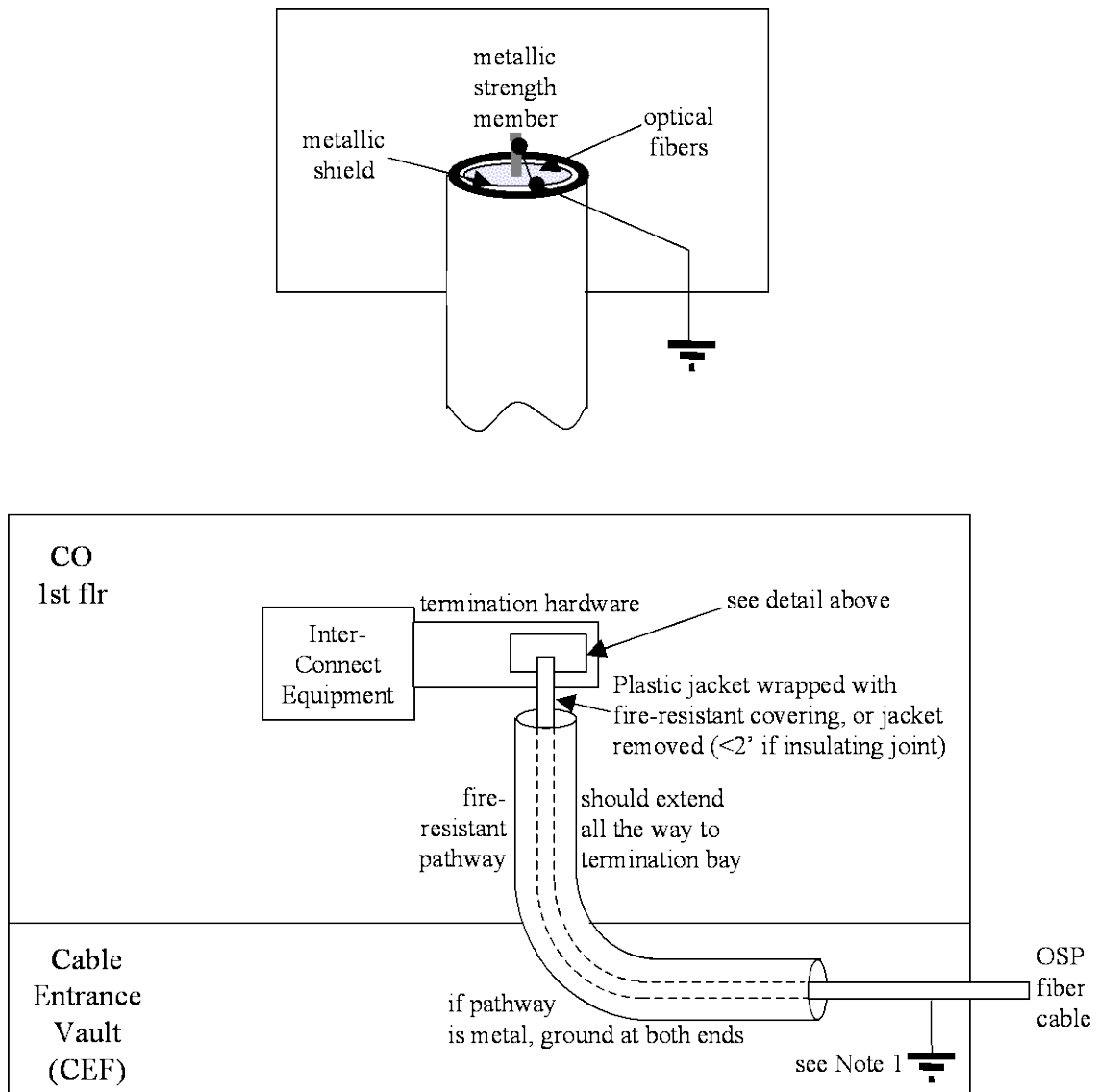

Figure 6-2: Underground CO Entrance Cable Incorporating an Insulating Joint



Notes:

- 1 All Metallic Members in the Fiber Cable Shall Be Grounded to the CO GRD at the CEF.
2. If Insulating Joint is Required, the Insulation Joint Shall Be placed in the CEF in A Standard Manner.

Figure 6-3: Bonding and Grounding of Optical Fiber Cable in Interconnect Equipment

CONTENTS

Chapter and Section	Page
7. Radio Equipment Ground Systems.....	7-1
7.1 Driven Ground Electrodes For Radio/Microwave Sites.....	7-1
7.2 Frame Grounding Methods.....	7-1
7.3 The Exterior Ring Ground System	7-2
7.4 Rooftop-Mounted Ring Grounds	7-3
7.5 Non-Metallic Antenna Structures.....	7-9
7.5.1 Metal Monopole Grounding	7-10
7.6 Waveguides and Transmission Lines	7-10
7.7 Tower Warning Lights	7-10
7.8 Metallic Feed Line Support Structure	7-11
7.9 Waveguide Hatchplate Bonds.....	7-11
7.10 The Interior Ring Bus System.....	7-13
7.11 The Interior-Exterior Ring Bonds	7-15
7.12 Supplementary Ring Grounding	7-17
7.13 Forming and Support of the Interior Ring Ground	7-20
7.14 Forming and Support of Supplementary Buses	7-22
7.15 Miscellaneous Unit Bonding	7-22
7.16 Conduit, Pipe and Duct Bonding	7-23
7.17 Bonding of Units Outside the Ring Ground Periphery.....	7-24
7.18 Building Structural Member Bonding Requirements.....	7-24
7.19 Telecommunications Facilities at Radio Stations	7-26
7.20 Environmental Considerations - Mountain Top Installations.....	7-26
7.21 Frame and Power Plant Return Bus Bonding Requirements	7-26
7.22 Power Service	7-32
7.23 Grounding Issues Related to Cellular/PCS or WiMax Antennas, or Collocated Microwave Dishes.....	7-34
7.23.1 Lightning Protection for Wireless Antennas.....	7-34
7.23.2 Tying the CenturyLink and Wireless Ground Electrode Fields Together	7-36
7.23.3 Power Service Entrance Protection for Wireless Equipment.....	7-43
7.23.4 Protection for a Power Interface Between CenturyLink and a Wireless Provider	7-44
7.23.5 Protection for Other Cabling Interfaces Between CenturyLink and a Wireless Services Provider	7-45
7.23.6 Grounding for Collocated Microwave Facilities	7-46
7.24 GPS Antenna Grounding Issues	7-47

CONTENTS (Continued)

Figures	Page
7-1 Microwave Ring Ground System and Principal Ground Bonds	7-4
7-2 Typical Grounding Arrangement for a Metal Antenna Tower.....	7-5
7-3 Grounding Arrangement for Wooden Antenna Supports	7-6
7-4 Grounding Arrangement for a 3 Pole Wooden Antenna Support	7-7
7-5 Grounding Arrangement for a Single Pole Wooden Antenna Support.....	7-8
7-6 Bonding of Outdoor Waveguide	7-14
7-7 Typical Arrangement of Peripheral and Exterior Ring Bus Bonds at Waveguide Hatchplates for Single Story Structures.....	7-15
7-8 Typical Arrangement of Peripheral and Exterior Ring Bus Bonds at Waveguide Hatchplates for Multistory Structures	7-16
7-9 Method of Bonding to 1/2" - 2" Conduit or Pipe.....	7-17
7-10 External Ground Bus for a Waveguide Hatchplate	7-18
7-11 Typical Ring Ground Installation in a Microwave Station	7-21
7-12 Wall Support Assembly for an Interior Ring Ground	7-27
7-13 Typical Supplementary Ground Crimp Connections.....	7-28
7-14 Method of Supporting Ring Bus Wire on Cable Rack and Connection of Bond Wire.....	7-29
7-15 Method of Supporting Supplementary or Interior Ground Ring Runs from Channel Framing	7-30
7-16 Typical Grounding of Antenna Tower Guy Wires	7-33
7-17 Grounding of a Typical Wireless Pole Site with a Metal Fence	7-35
7-18 Grounding Interface Between a Typical Wireless Pole Site and a CO.....	7-36
7-19 Grounding of Wireless Equipment Mounted to an Existing Roof Tower	7-37
7-20 Typical Grounding of Wireless Equipment Mounted on a Building Roof ...	7-38
7-21 Ideal Grounding Interface Between the Ground Electrode Field of a Wireless Site and a CenturyLink CO Ground Ring.....	7-39
7-22 Grounding Interface Between the Ground Electrode Field of a Wireless Site and a CenturyLink CO, Using a Deep Driven Rod, Counterpoise, or Chemical Ground (Ground Well) System.....	7-40
7-23 Grounding Interface Between the Ground Electrode Field of a Wireless Site and a CenturyLink CO that only has the Power Company MGN as a Ground Electrode Field.....	7-41
7-24 Grounding Interface Between a Wireless Site and a CenturyLink CO where CenturyLink is Providing the AC Power from Within their Building.....	7-42
7-25 Wireless Pole Mounted Antenna Grounding Details.....	7-43
7-26 Rooftop GPS Antenna Grounding Detail	7-49

7. Radio Equipment Ground Systems and Rooftop Lightning Protection

7.1 Driven Ground Electrodes for Radio/Microwave Sites

Ring Ground System (RGS) general requirements for establishment of driven ground electrodes for Microwave Radio sites that are susceptible to frequent lightning exposure, are based on principles covered in this section. The system is essentially similar to that employed for central offices. The ring is extended around and bonded to the antenna tower legs. Other metallic objects on the premises and on the exterior of the building (such as fences, gutters, down spouts, pipes, air conditioning units and other conductive structures that might constitute a hazard due to excessive voltage and arcing during lightning strokes) are bonded to the grounding electrode system. Rods, wire, connectors, and other material used in the construction and placement of such material are identical to that described for the driven ground electrode for central offices. One exception is the method of extending the Ring Ground electrode into the building interior. Stations of this type employ an interior grounding ring conductor as part of the lightning protection feature. Connections are required between the exterior and interior grounding rings at approximate intervals of 50 feet or less, with a minimum of four, located near the building corners. The method of entry is through nonmetallic conduit, where the entering conductors are routed vertically on the interior wall to connect to the interior ring grounding conductors. The entire interior ring ground then functions, in addition to its function of lightning protection, as the office principal ground point.

7.2 Frame Grounding Methods

Treat radio equipment as an integrated ground plane. Bond all frames to the nearest ground reference. Depending upon each office layout, the nearest ground reference could be the CO GRD, the OPGPB, or the interior ring ground.

Note: All grounding or grounded conductors associated with radio gear that can conduct lightning currents (this includes shields and the outer conductor of coaxial cables) should be kept as far away as practical from any isolated ground plane within the building structure.

7.3 The Exterior Ring Ground System

The exterior ring ground system establishes a station ground electrode that tends to equalize potentials in the earth surrounding the building and towers, regardless of earth resistivity, by ensuring that a low impedance current path exists throughout the area. The system is comprised of exterior ring ground conductors encircling the building and tower. The ring is composed of a No. 2 AWG solid tinned copper wire buried at least 30 inches below grade and spaced 2 feet minimum from building foundation and tower footings. The ends of the wires are joined together to form a ring. Driven ground rods are typically connected to the bus at 10 to 20 foot intervals as described in paragraph 3.2 (see Figure 7-1). Under adverse soil resistivity conditions or when bedrock prohibits driving of rods, horizontal counterpoise conductors are employed to improve equalization of the system.

Figure 7-1 illustrates a typical exterior-interior ring bus system and the relationship between various components of the ring ground system. As shown therein, the exterior ring ground is bonded to the tower legs, to exterior buried and above surface metallic objects, to other electrodes, and to the interior ring ground and waveguide hatch plates. The tower ring portion is bonded with two No. 2 AWG solid tinned copper conductors to the building ring ground. Figures 7-1 and 7-2 illustrate a typical exterior ring-ground tower bonded to the metal antenna tower legs. When metal towers are installed, proper grounding procedures should be followed to prevent damage to the tower support footings. If lightning energy is forced to flow to earth through the concrete footings, the concrete can become super-heated and may "explode" as embedded moisture turns into steam in the confined space, thus causing damage. If the solid #2 AWG needs to be run through the concrete, then it must be routed in a non-metallic conduit. Rebar-embedded concrete footings (Ufer ground) can serve as a supplementary grounding electrode (see Section 3.2.8).

If the antenna tower has metal guy wires for support, the guy wires must be grounded by adding a buried No. 2 AWG solid tinned copper conductor in a ring configuration and connecting each guy wire to the No. 2 ground conductor. Connect this ground ring to the driven ground system with two bonds. If the guy wires are spread out at a long distance, install a ground rod at each guy wire end and connect a ground wire from the anchor head or the guy wire to the ground rod. Then run a No. 2 AWG to the tower or to the building ring ground system (see figure 7-16).

A separate buried exterior ring ground around the building is not required when the building is a central office, wherein the radio equipment area comprises a relatively minor part of the communication equipment area, and the building is adequately grounded by means as described in paragraph 3.1.

Many radio sites are located in rocky areas where proper grounding is difficult to maintain. Enhanced grounding methods may be provided as follows (these methods are described in further detail in Section 3.2):

- Rods inserted in drilled holes and backfilled with Bentonite, Calcine petroleum coke or low-grade concrete
- A counterpoise grounding system
- Deep driven rods, or wells cased with steel pipe

Note: Rods enclosed in bags of chemically treated backfill are prohibited in CenturyLink for environmental reasons.

All grounded metallic objects external to or mounted on the building must be bonded to the exterior ring ground to ensure equalization of potential (see bonding requirements ANSI/EIA-222-D and ANSI/NFPA 780 Lightning Protection Standard).

Unit bonds connected to the exterior ring ground shall be No. 2 AWG bare tinned solid copper conductor. Connections to ring conductors shall be made with an exothermic weld, when buried. Connections to above ground units may be made with exothermic weld. Crimp type connections on solid wire can be made using the appropriate connector, crimping tool, and die approved for solid wire. Connectors other than exothermic weld shall be located to facilitate periodic inspection and maintenance.

A "tree" is generally applicable to grounding on the building exterior. A "tree" system consists of a single conductor run from a ground point in a generally direct route toward a group of units requiring grounding. Branch conductors are extended to individual units from points on the main or "trunk" conductor. Sub-branches may also be extended from branch conductors. The trunk conductor is extended to the furthest unit from the ground point.

7.4 Rooftop-Mounted Ring Grounds

An external grounding system for radio/microwave structures, including waveguides and feed lines, is necessary for the dispersal of lightning current to earth before it is able to enter the site. It is impossible to prevent all surge current from entering the building due to the multiple metallic paths between the building exterior and interior, but most of the current can be controlled and diverted. Unless stated, this section uses the practices of the Lightning Protection System Installation Standard (ANSI/NFPA 780).

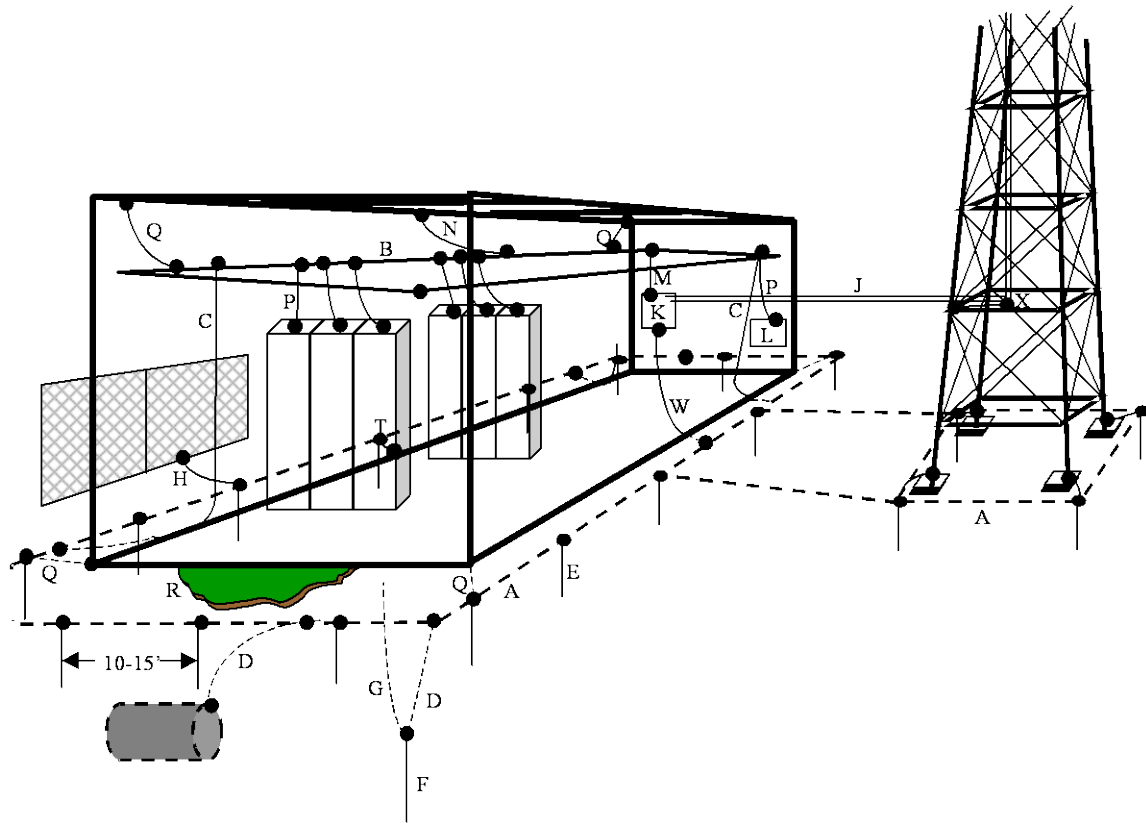

LEGEND

- | | |
|--|--|
| (A) Buried Exterior Ring Bus | (B) Peripheral Bus (Interior Ring Ground) |
| (C) Inter-Bus Bond (@ all 4 corners) | (D) Bond to Buried Objects |
| (E) Ground Rod | (F) Power Company Grounding Electrode |
| (G) Power Company Neutral Bond | (H) Bond to Fence Within 6 Feet |
| (J) Waveguide (Rectangular, Circular, Elliptical, Helix, Coax, etc.) | (L) Wall-Mounted Cabinet |
| (K) Waveguide Hatch | (N) Supplementary Bond |
| (M) Hatch Bond | (Q) Building Steel Bond |
| (P) Equipment Bond | (T) Bond to Metallic Object or Building Exterior |
| (R) Grade Level | (X) Waveguide Vertical to Horizontal Transition |
| (W) Waveguide Hatch Primary Bond | |

Figure 7-1: Microwave Ring Ground System and Principal Ground Bonds

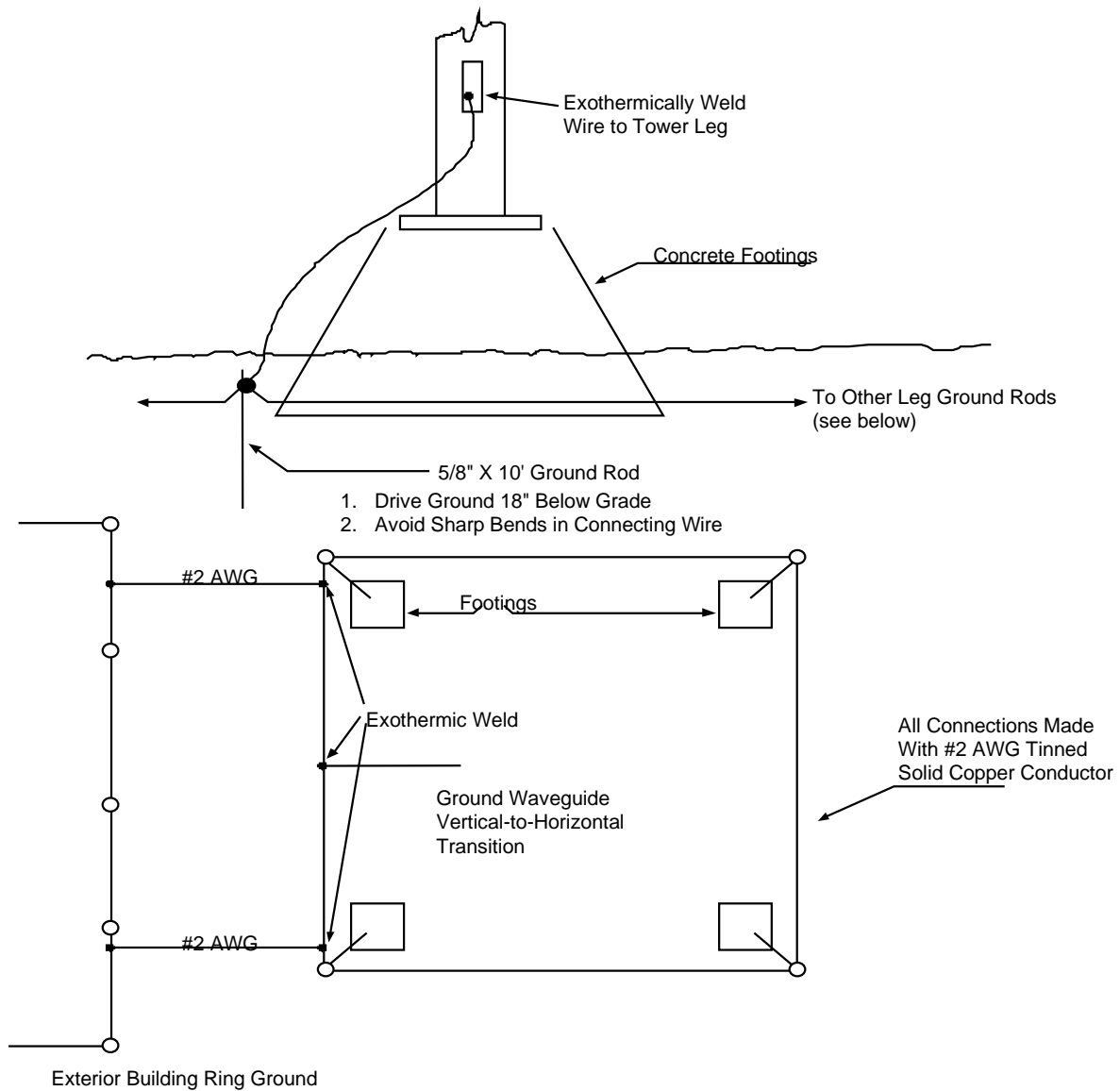
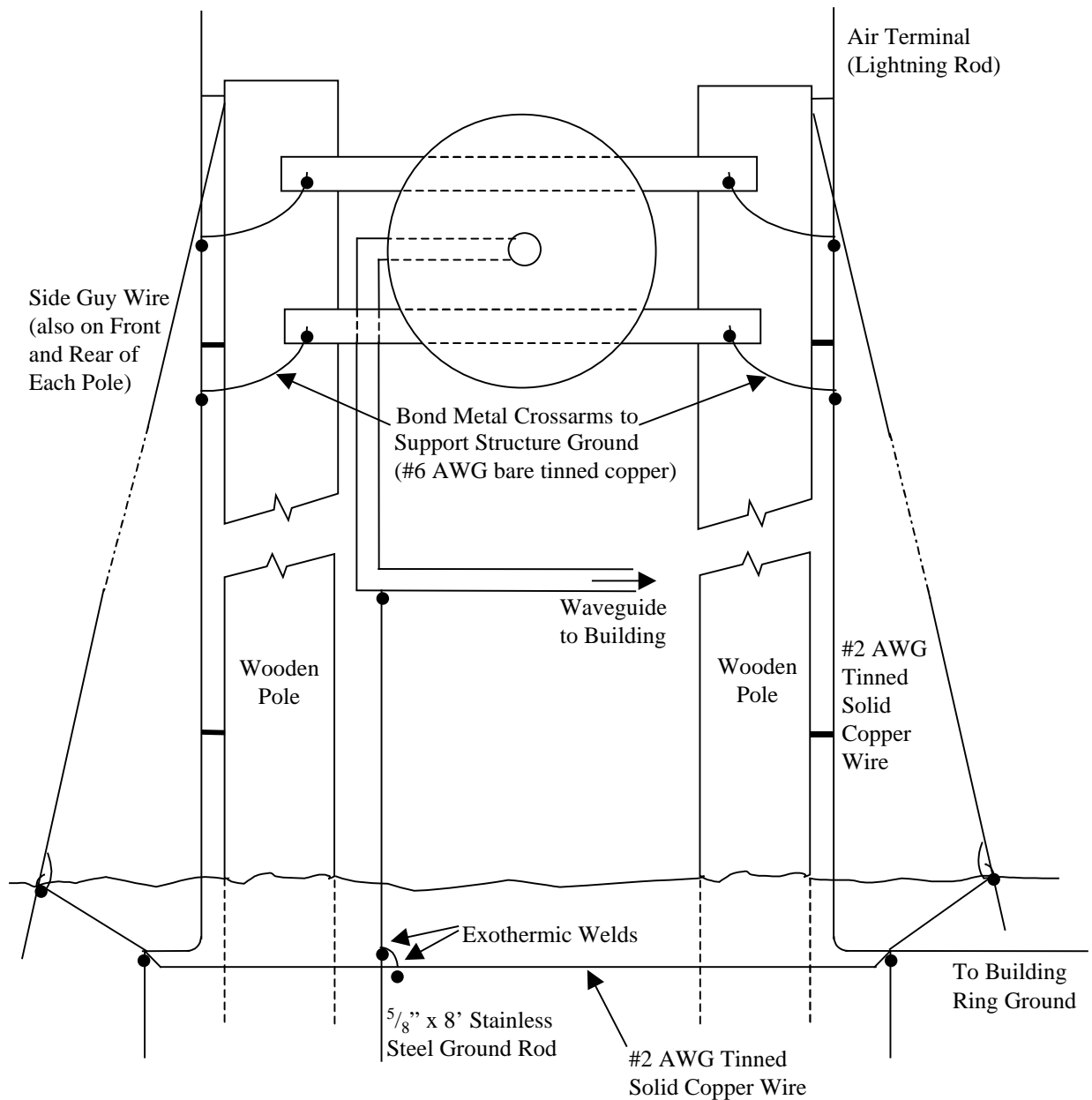

Figure 7-2: Typical Grounding Arrangement for a Metal Antenna Tower



Notes:

1. Extend wire 8 to 12 inches above the top of the poles
2. Mount the antenna below the pole tops
3. Ground the waveguide vertical-to-horizontal transitions

Figure 7-3: Grounding Arrangement For Wooden Antenna Supports

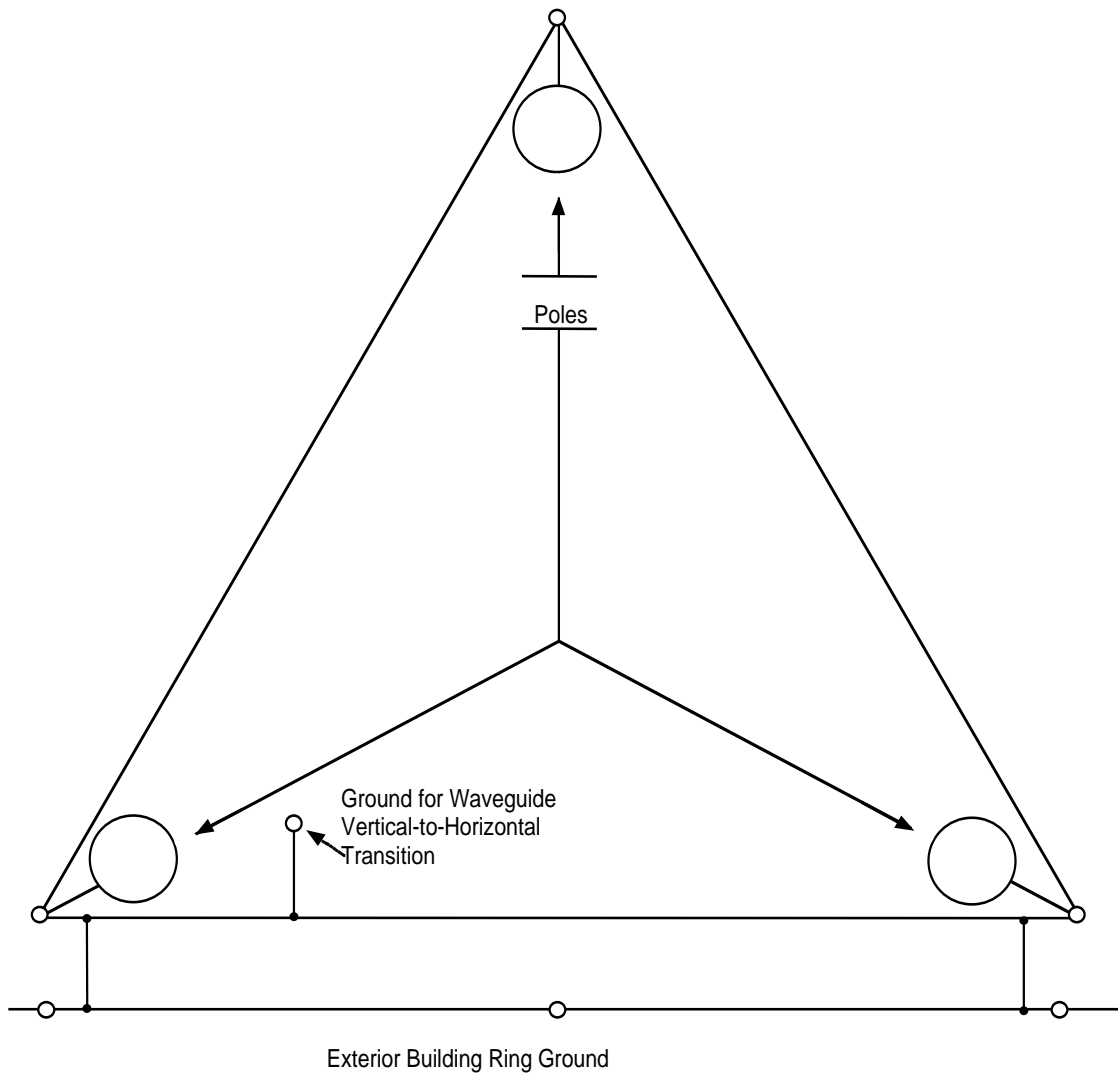

Notes:

1. Make all connections with No. 2 AWG tinned solid copper wire.
2. All connections to be exothermic process.
3. Add air terminal to top of pole and ground to tower ring ground.
4. Use 5/8" X 8' (or 10') ground rods 10' - 20' apart.
5. Crossarms and antennas omitted for clarity.

Figure 7-4: Grounding Arrangement for a 3 Pole Wooden Antenna Support

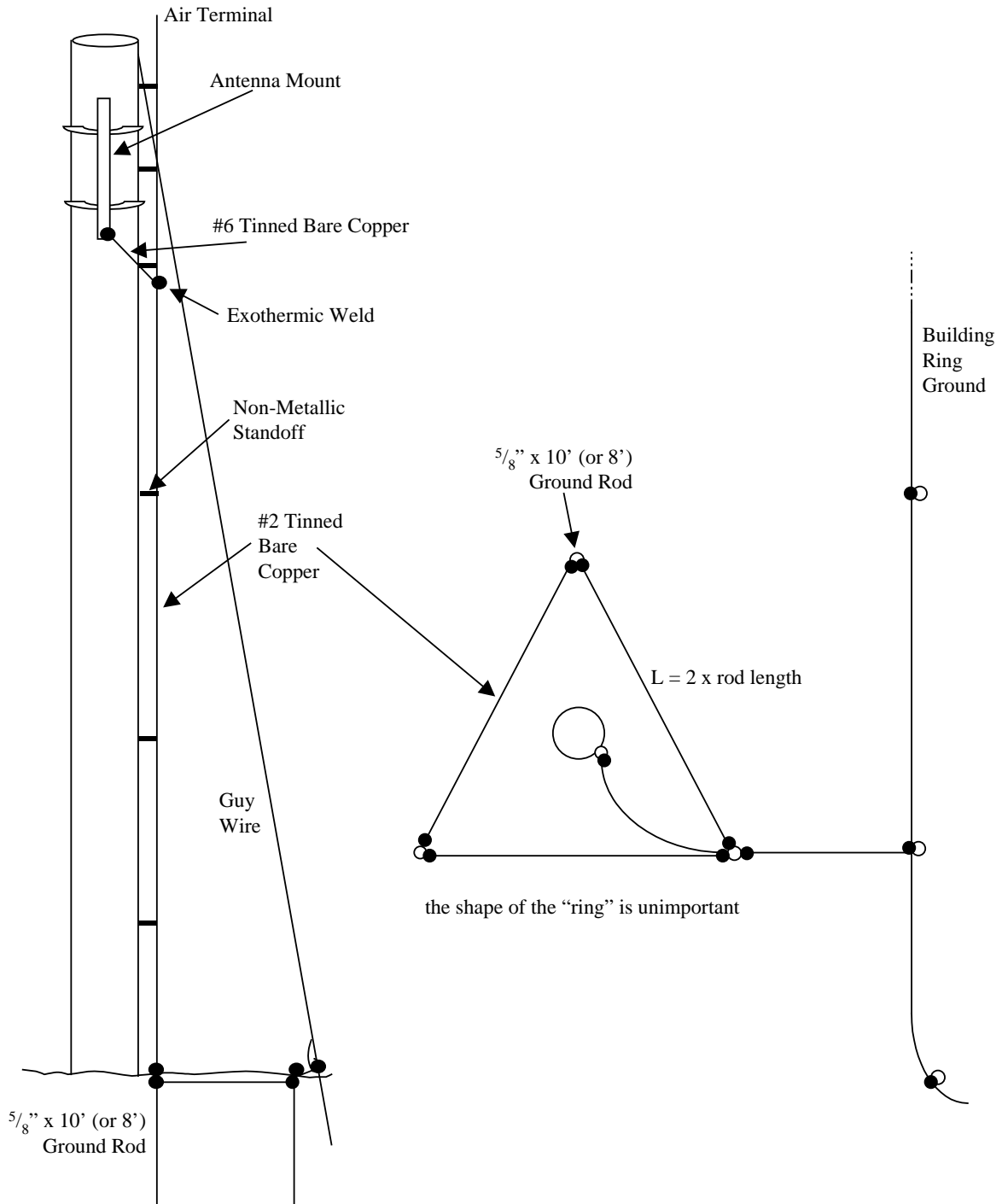

Figure 7-5: Grounding Arrangement for a Single Pole Wooden Antenna Support

Rooftop towers increase the lightning risk for the building. Due to their height and lightning risk probability, all buildings with rooftop towers shall be equipped with an NFPA 780 lightning protection system. Other metal objects on the roof with metallic connections to the building interior (such as air-conditioning units) are only required to use a lightning protection system or downleader(s) if they are taller than 5 feet and if their top height exceeds 25 feet above the ground. However, if there is a lightning protection system on the roof for other reasons, all metal objects on the roof that have metallic connection to the building interior, and are taller than 2 feet, should be bonded to it with a minimum #6 AWG copper conductor. In addition to these requirements, tower support legs shall be interconnected with a bonding ring of #2 AWG minimum at its attachment to the roof structure. This ring shall be bonded to the main perimeter lightning protection roof ring by at least two opposing conductors of #2 AWG or larger, at or within 24 inches of a downleader. All tower guys/anchors that attach directly to the building shall be bonded to the roof perimeter ring. Per NFPA 780, if the structure is non-conductive, then multiple exterior downleaders shall be used, each with a minimum current-carrying capacity of a No. 2 AWG. These downleaders should be kept at least 6 feet from external conductive metal objects in the vertical portion of their run to prevent flashover during a lightning strike. They should also be at least 3 feet away (measured horizontally through the wall) from any metal internal to the building.

Transmission lines and waveguides should be grounded where they make directional transitions, especially the vertical-horizontal near the tower bottom. The transmission line should be bonded to the grounded entry hatch both inside and outside.

7.5 Non-Metallic Antenna Structures

One, two, and three pole wooden support structures are used in CenturyLink. The 3-pole structure is less susceptible to torsion and is preferred. These structures should be grounded as shown in Figures 7-3 through 7-5. For a wood structure, it is advisable to mount the antennas with their extremities below the top of the structure and add an air terminal on top of the pole. (In addition to Figures 7-3 and 7-5, see Figures 7-19, 7-20 and 7-25 for examples.) Ground the air terminal to the antenna tower ring ground. (Air terminals are commonly referred to as Franklin rods or lightning rods, and their proper use and installation is governed by NFPA 780.) When lightning strikes occur, the energy will be kept off the antenna and transmission lines as much as possible.

7.5.1 Metal Monopole Grounding

Metal Monopoles, instead of the wooden support structures mentioned above are being used with increasing frequency (see Section 7.23 for examples). Grounding of these monopoles when used for microwave transmission (as opposed to PCS or Cellular, whose grounding is covered in Section 7.23) should be similar to what is shown in the top halves of Figures 7-16 and 7-2. As an alternative to running the ground wire outside the concrete footing (as depicted in the top half of Figure 7-2), a non-metallic conduit may be placed inside the footing, in which the ground wire may be run. It is only required to connect to the ground ring with at one point (as shown in Figure 7-5), but two or more connections are better.

7.6 Waveguides and Transmission Lines

Waveguides and transmission lines should be bonded and run as directly as possible to the metallic tower at the top and bottom of the vertical run on the structure. Additional bonds are required per NFPA 780, where towers are over 200 feet. Additional bonds may be used across flexible sections of waveguide (see Figure 7-6), and at support points where flashover/ arcing potential exists from non-insulated waveguide. The bond at the bottom of the vertical waveguide run should be applied just above the point where the waveguide bends to the horizontal plane. For small cross-section waveguide, the connectors for the bonding strap may necessitate conductors as small as 16 AWG, but normally they should be as large as possible up to a maximum of 6 AWG.

If connectors with inspection holes are used on bonds for flexible waveguide bonding jumpers, these bonds must be sealed to prevent corrosion. An appropriate corrosion prevention product is weatherproof heatshrink that contains an emulsion. Not sealing these crimp type connections will allow moisture to accumulate in the crimp and in the wire under the outer covering, and this will corrode the connection. Because these connectors are bent at 90 degrees to allow a flange connection at Flex Waveguide, it may not be possible to ensure that the heatshrink adequately seals the inspection hole. If an adequate seal is not obtained, then connectors without the inspection hole should be used, including an appropriate corrosion prevention product.

7.7 Tower Warning Lights

Towers that have aircraft warning lights shall enclose all AC power conductors in metal conduit. The conduit shall be supported at least every 10 feet and within 18 inches of any conduit body to meet NEC Articles 314.23E, and F. Expansion joints for the metallic conduit shall be bonded with a copper conductor of No. 6 AWG. The power to the tower lighting system shall have a suitable fast (less than 10 nano-second response time) low voltage surge protection device installed outside the serving building at the point it enters the structure. The surge protection device shall be grounded to the external rooftop grounding electrode system or to the tower roof ring ground. The CenturyLink Electrical Protection Engineer can answer questions on this section.

7.8 Metallic Feed Line Support Structure

Where a metal frame is used to support waveguides and coax between the tower and the building, the frame should be bonded to the tower or the tower ring ground with a No. 6 AWG conductor or larger. At the building, the waveguides and supporting structure and the entrance hatch are bonded together and the hatch is connected directly to the external ring ground at the station with a No. 2 AWG conductor. (Some of this metallic support structure, when located above the waveguide for protection from the elements, is called an “ice bridge”.)

7.9 Waveguide Hatchplate Bonds

Waveguides, metallic supportive framework, and tower lighting system conduits extend the current path from the tower to the building. All external metal conductors (like waveguides) shall be bonded to the external ground ring at the point of entry. All conductors entering a radio facility shall be bonded to the internal ring ground system within three feet of the entry point. The only building entrance points for any metallic facility in a CenturyLink site are waveguide hatchplates (as described in this chapter), the cable entrance facility (see chapter 6), and the AC service entrance.

The waveguides can be bonded to the hatchplate by the mounting flanges furnished with the pressure window section that passes through the hatchplate. If the mounting flanges do not make metal to metal contact to the hatchplate then the waveguides need to be bonded together with a No. 6 cable and grounded to the hatchplate. Waveguide and transmission lines can also enter a building through building entries or feed-through assembly hatchplates. These entries or feed-through assemblies allow waveguide and transmission lines to pass through without making metallic contact with the hatchplate and shall be bonded individually and externally on the hatchplate with a No. 6 AWG grounding cable. Where an RF transmission line, other than rigid or elliptical waveguide, passes through the hatchplate, it shall be connected to a Listed overvoltage protection device and grounded before entering the building.

Metallic supportive framework shall be bonded with a No. 2 AWG bond to the hatchplate exterior surface with a two hole compression connector if it is not mechanically connected to establish continuity.

Conduit entering the building in proximity to the hatchplate shall be bonded to the hatchplate exterior. If the conduit is run on the building exterior before entering, it shall be bonded to the exterior ring bus or roof ring ground. This bond shall be made immediately prior to entry through the building wall or roof. The conduit shall also be bonded to the interior ring bus system immediately on entry into the area served by the ring bus.

An appropriate corrosion prevention product for these hatchplate bonds is weatherproof heatshrink that contains an emulsion. Not sealing these crimp type connections will allow moisture to accumulate in the crimp and in the wire under the outer covering and corrode the connection. Transmission line bonds for hatch or hatch bus ground connections can be purchased with two-hole connectors already attached, or included as part of the grounding kit, including the appropriate weather seal.

The hatchplate shall be bonded directly to earth with a primary bond, as described in paragraph 7.11, "The Interior-Exterior Ring Bonds", when a buried exterior ring ground exists. When hatchplates are located in the roof, the primary bond shall be bonded to the roof ring ground (or lacking a roof ring ground, to a downleader going down the outside of the building to the external ground electrode field). The primary bond shall be connected to the hatchplate on the inside, routed in proximity to, and connected to the interior ring ground. (In some COs where microwave radio and/or other waveguides or external transmission lines are not the primary purpose of the CO, there may not be a ring ground. In these cases, a direct #2 AWG minimum bond from the hatchplate to a nearby COGB or OPGP is required. This bond shall be routed as near as possible to external walls and to ceilings, and as far away as possible from other equipment frames). It shall be extended to the CO ground bus in multistory buildings (with a minimum #6 AWG, and to the external ring ground (in PVC conduit, if conduit is used at all) in single story buildings (see Figures 7-7 or 7-8).

The modern method for bonding and grounding the external hatchplate and entering waveguides is to mount a ground bar below the hatchplate (see Figure 7-10). Bond the hatchplate to this bar as well as all of the entering waveguides. Then tie the bar to the exterior ground ring. If the external ground ring can't be accessed, the bar can be tied to a new ground electrode field (see Figures 7-22 and 3-6 for 3-rod minimum configurations), but this field must also be bonded to the OPGP.

Normally, only one metallic plate is installed approximately in the center of the opening in the building, bonded both internally and externally, as shown in Figures 7-7 and 7-8. The hatchplate shown in Figure 7-10 is a little different in that it is externally mounted (rather than centered in the opening. Generally, this is good enough, and a second metallic plate mounted to the inner wall is not necessary, nor desired. In cases where both an exterior and interior plate are used, a #2 AWG minimum bond shall be made between the plates.

Waveguides require no interbonding to the interior ring ground when the hatchplate is located within 25 feet of the interior ring ground system. When the hatchplate is further away, as when antennas are roof mounted and radio equipment is on a lower floor of a multifloor CO, waveguides shall be bonded to the interior ring ground (or to the direct hatchplate-to-COGB conductor). Waveguides within 6 feet of each other shall be bonded together with No. 6 wire, similar to the multiple conduit bonding arrangement shown in Figure 7-9. The bond shall be extended to an interior ring ground or supplementary bus. The bonding point shall be at the waveguides' entry point into the area protected by the interior ring ground. In this arrangement, the waveguides act as discharge current paths between the hatchplate and interior ring ground system. Primary bonds between such remote hatchplates and interior ring ground may be omitted when waveguides are so bonded (see Figure 7-6).

7.10 The Interior Ring Bus System

The Interior Ring Bus System consists of the following:

- A No. 2 AWG insulated stranded copper wire extended around the periphery of the radio equipment area
- A number of No. 2 AWG bonds between the interior ring ground and the exterior buried ring ground
- Supplementary buses
- Unit bonds to equipment frames
- Bonds to miscellaneous metal (auxiliary framing, metal conduits, air-conditioning duct, cable racks, etc.) within the interior ring ground periphery. In order to ensure the best possible Faraday cage, cable racks within this interior radio ring ground should be positively joined by #6 AWG or larger bonding jumpers run between cable rack sections. The bonding jumpers shall be installed with two-hole irreversible crimp compression lugs with the paint scraped at the connection points on the cable rack

The system is illustrated in Figures 7-1 and 7-1. It provides a means of establishing low impedance between neighboring metallic objects within the communication building, and a low impedance path between that bonding network and earth. Any metallic object within, or which is part of, the building may function as a current path during discharge, dependent on its relationship in terms of coupling to the focal point of current flow between the tower and the building interior, and to earth. The probable focal point is assumed to be the waveguide hatchplate (or hatchplates) or coaxial cable outer sheath.

No grounding conductor coming from radio-related equipment (such as the interior ring, bonds to the waveguide hatchplate, etc.) should ever pass within 3' of an isolated ground plane. They should be as far away as possible (preferably greater than 10 feet).

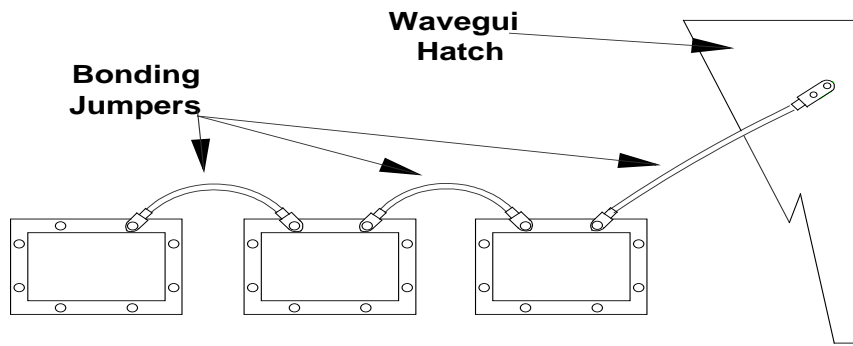

Bonding Outdoor Waveguide Flanges to Waveguide Hatch (Typical)

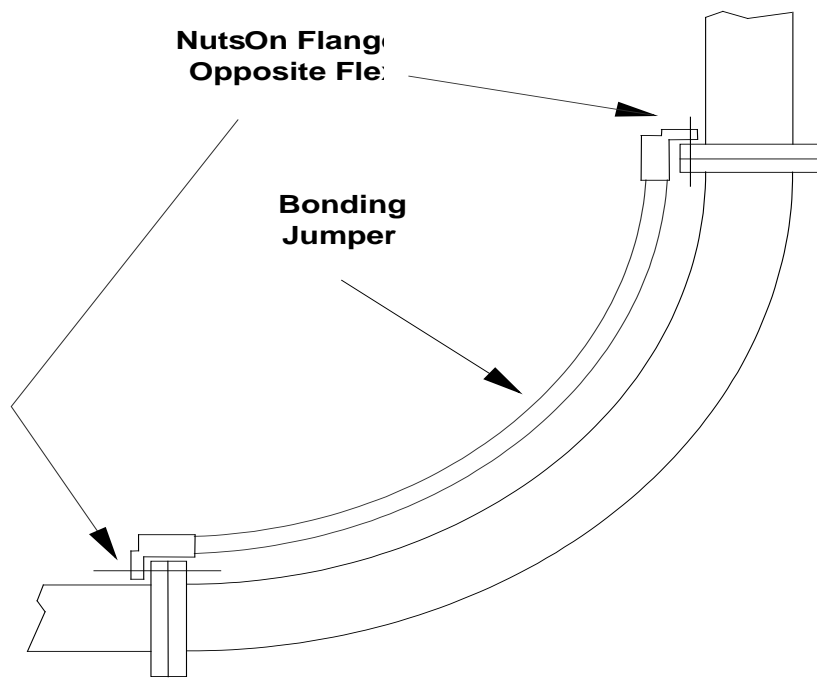

Flex Waveguide Bond (Typical)

Figure 7-6: Bonding of Outdoor Waveguide

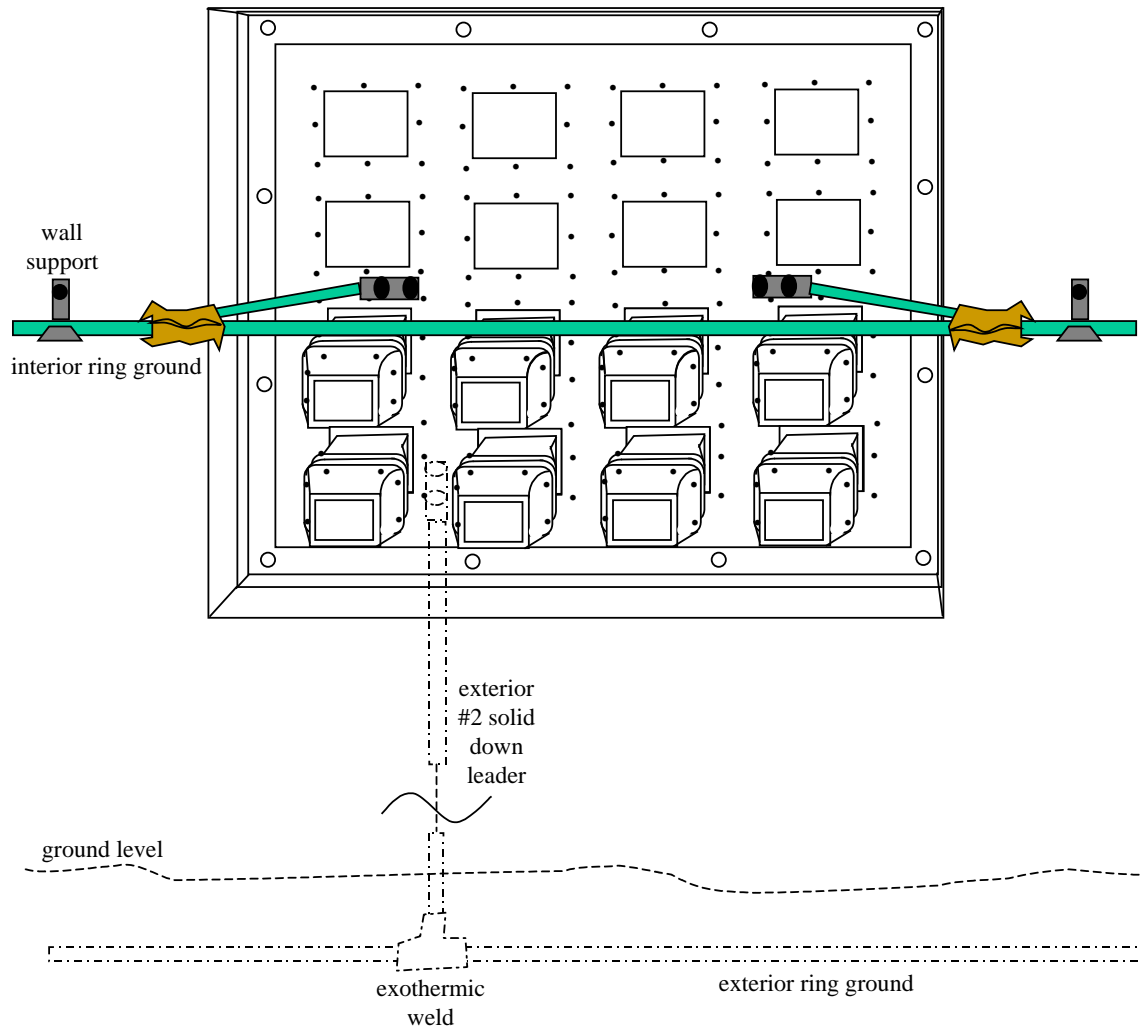

Figure 7-7: Typical Arrangement of Peripheral and Exterior Ring Bus Bonds at Waveguide Hatchplates for Single Story Structures

7.11 The Interior-Exterior Ring Bonds

When a buried exterior ring ground system is the site's ground electrode, multiple bonds (#2 AWG solid, tinned; at least every 50 feet) are required between that system and the interior ring ground. These bonds complete the low impedance current path between waveguide hatchplates and earth. Preferably, bonds between the interior and exterior ring are made at each corner of the building).

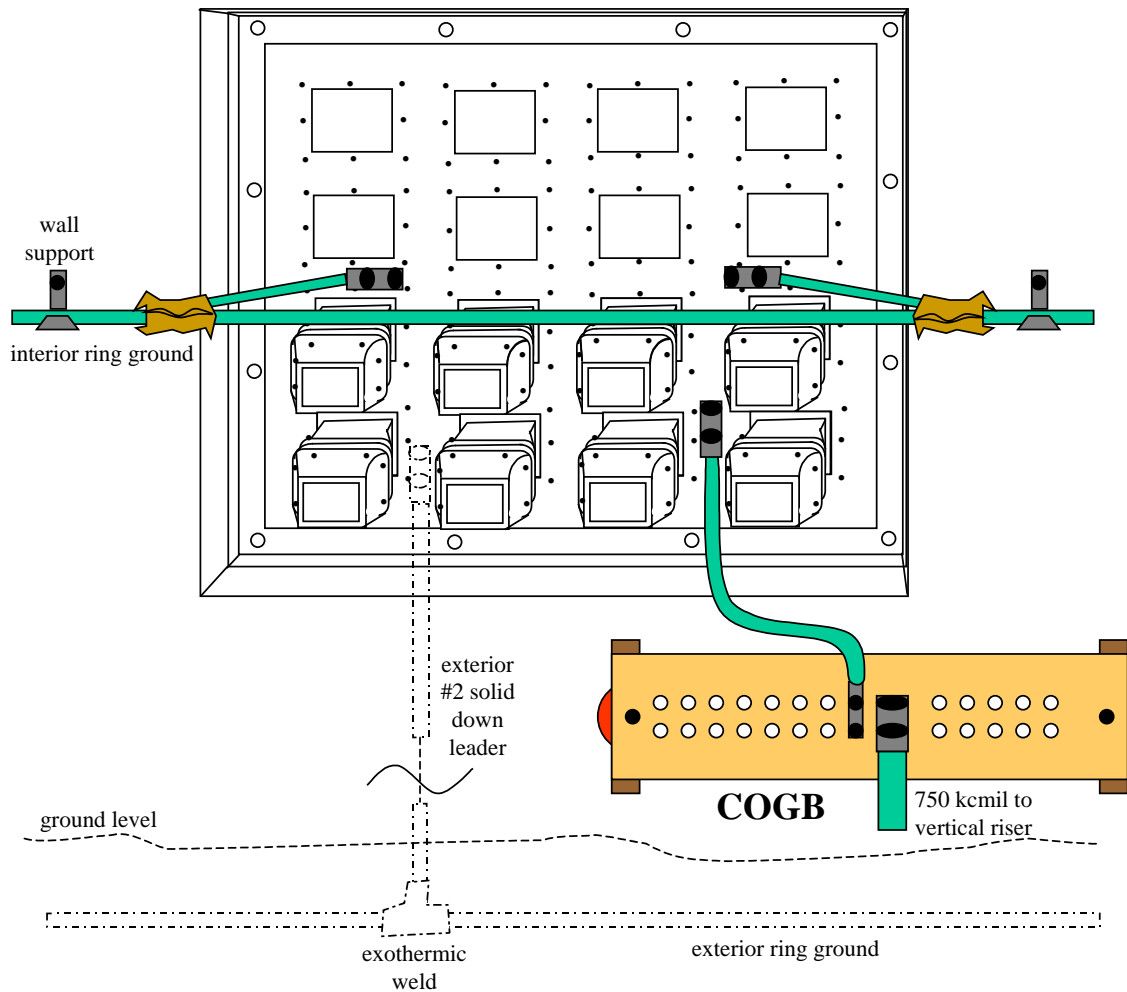
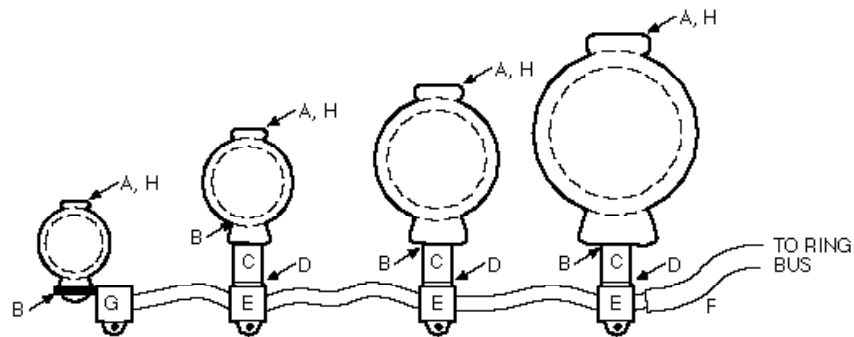

Figure 7-8: Typical Arrangement of Peripheral and Exterior Ring Bus Bonds at Waveguide Hatchplates for Multistory Structures

Crimp connections to solid copper wire must be made with the appropriate connector, crimping tool and die designed for solid wire. Termination of stranded wire on the hatchplate must be made with a two-hole bolted tongue crimp connector. The solid wire may alternatively be joined to the stranded wire with an exothermic weld connection or extended to the hatchplate. Exothermic weld type two-hole bolted tongue connectors must be used to terminate solid wire to the hatchplate. The primary bond wire shall be supported on the interior wall with supports as shown in Figures 7-12 and 7-13. Unnecessary bends shall be avoided. Necessary bends shall have an 8 inch radius or greater (12" minimum bend radius is preferred for grounding conductors).



Legend:

- | | |
|---------------------------------|---|
| (A) Conduit Clip | (E) Steel Clamp |
| (B) RHM Screw LockWasher | (F) #6 or #2 AWG insulated, stranded |
| (C) Bracket | (G) Use 2 clamps for a 2-hole crimp lug |
| (D) RHM Screw LockWasher HexNut | (H) Clip must conform to conduit size |

Notes:

1. In lieu of the clips, conduit clamps may be used.

Figure 7-9: Method of Bonding to 1/2" - 2" Conduit or Pipe

7.12 Supplementary Ring Grounding

Metallic objects in the radio area must be bonded to the interior ring ground.

For COs with switches where there are 4 or fewer bays of radio equipment, an interior ring around the radio bays is not necessary. However, these bays should have their own minimum #2 AWG stringer run directly to a COGB or OPGP / PANI MGB.

(Special consideration needs to be given to metallic conduit using "set screw" type fittings due to the poor bond these fittings provide. If these were used [although they are generally not allowed going forward], all conduit joints must be bonded together with a minimum #6 AWG conductor.)

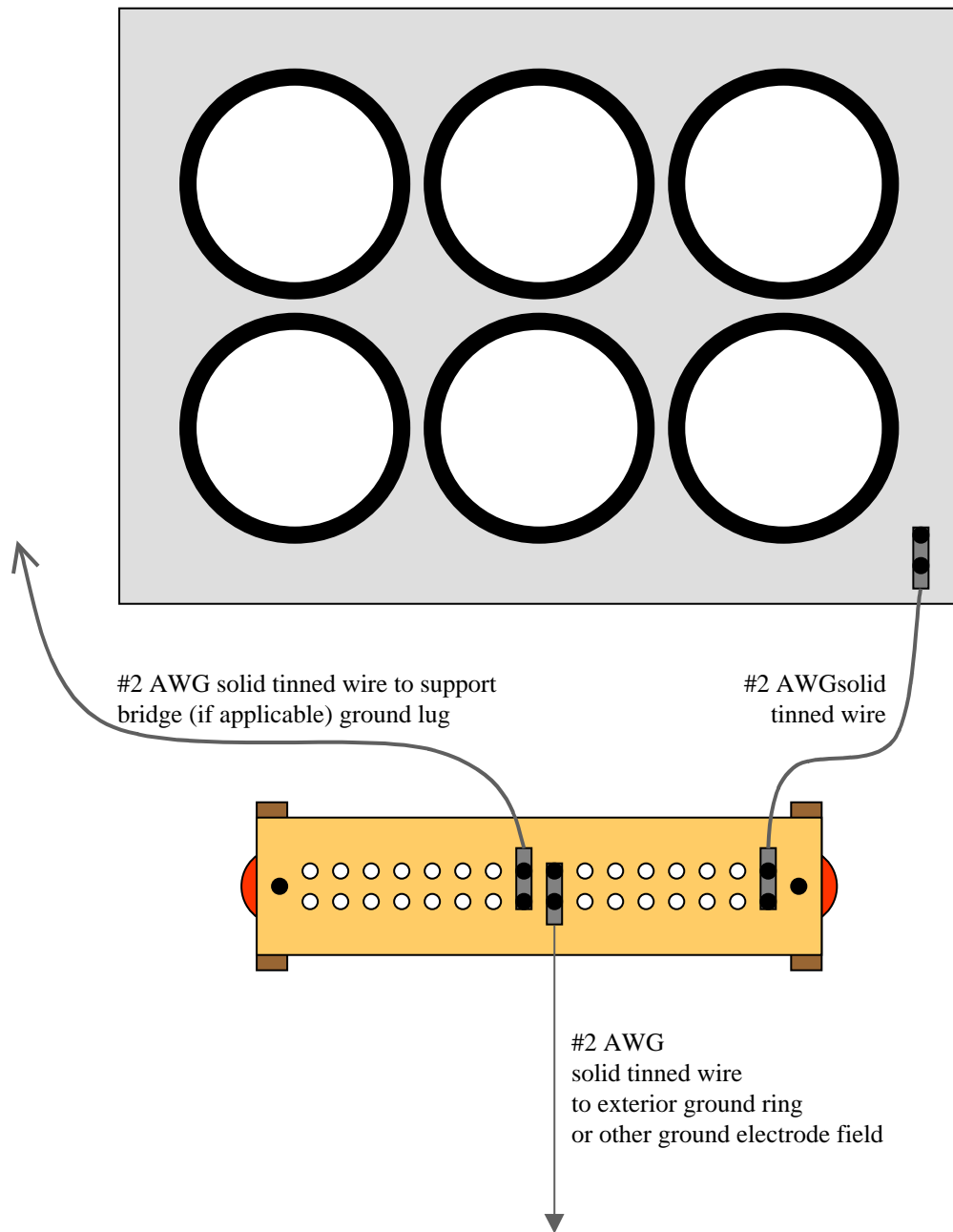

Figure 7-10: External Ground Bus for a Waveguide Hatchplate

Additionally, objects within 6 feet mutual proximity must also be bonded. This is normally accomplished via paths established by unit bonds connected to the interior ring ground. Impedance of such inter-connective paths is dependent on the length of the path; therefore, a practical limitation of path length is necessary to ensure effective equalization. For this purpose, the following general guidelines are presented as a guide in determining acceptable path lengths:

- For objects located within one foot of each other, the bond path length shall not exceed 15 feet.
- For objects located from one to six feet of each other, the bond path length shall not exceed 30 feet.
- When either of the first two bullets cannot be met, a supplementary ring ground shall be provided, or direct bonds between objects shall be provided in addition to bonds to the ring, to meet the requirements stated in the first two bullet items.

Notes:

1. Bond path length shall be calculated as the shortest path between points of closest proximity of the two objects via the objects' metal and interconnection bond paths.
 2. Mechanical connections between objects (e.g., inter-frame bolting) shall not be considered as a bond path except where the interconnection device is a junctioned ground or an equivalent device intended for frame line grounding purposes.
- The preceding rules are not always applicable to every occurrence of object proximity. They express limits considered desirable to ensure equalization of potential. In certain cases, it will be expeditious to exceed the length limits for physical or economic reasons. Where limits are exceeded via the path through unit bonds and ring ground, and where the addition of a direct bond between objects or ring ground is not practical, under no circumstance shall the lengths be more than double the lengths expressed in the guidelines.
 - The inter-object bond shall be kept as short as possible. In order to facilitate this objective, supplementary buses shall be provided over frame lines within the area bounded by the interior ring ground.
 - Supplementary ring ground arrangements are shown in Figure 7-13. Supplementary ring grounds shall be provided as required to satisfy the inter-object bonding requirements. These ring grounds also function to provide minimal length low impedance paths between the current focal points (hatchplates) and earth, in parallel with interior ring grounds. To provide a parallel path, the supplementary ring grounds must be connected at both ends to the interior ring ground. The ring ground conductor shall be the same as that of the interior ring ground.

7.13 Forming and Support of the Interior Ring Ground

Crimp type parallel connectors or exothermic welds are recommended for bonds to the interior ring ground. Space for tools between the supporting surfaces and wire is necessary to make such bonds. A standoff support assembly, as shown in Figure 7-13 is recommended for support of wire on walls. A nylon expansion anchor, as illustrated, shall always be used. Supports shall be provided at approximately 2 foot intervals. Additional supports at points that tend to distort the interior ring ground, such as at bonding points, may be provided on basis of need. The interior ring ground conductor, not run on walls, is generally supported from cable racks framing channels, or fire rated wood sleepers (see "Supplementary Buses" for method support).

When stranded wire and exothermic welds or crimp type parallel connectors are employed, the interior ring ground need not be installed as a single continuous run of wire. Unnecessary splices should be avoided, but where installation is greatly simplified by installing the interior ring ground in several segments, with the segments joined by an exothermic weld (preferred) or crimp type parallel connector, such segmentation is permissible. Solid wire interior ring ground may be segmented only if segments are joined with an exothermic weld or an approved crimp type connection.

To minimize impedance and the incidence of arcing, the interior ring ground shall be installed with a minimum number of bends, and such bends as are required shall be made with the greatest practical radius. The bend radius shall not be less than 1 foot. Use of 90° bends to route around obstructions shall be avoided when lesser bends (e.g., 45°) can be adequately supported. The probability of arcing may be significantly increased by unnecessary bends.

Any closed ring of metal around a ground conductor acts as an inductive impedance to the flow of other than steady state discharge current. For this reason, routing of ground conductors through metallic objects that form a ring around the conductor, such as metallic conduits is prohibited. Use of non-metallic material such as PVC plastic conduit is recommended. Where use of metal conduit is unavoidable (e.g., non-metallic conduit prohibited by local code), the ground conductor shall be bonded to each end of the metal conduit:

- To avoid increasing inductive impedance.
- To reduce voltage drop by paralleling the metal conduit conductance with that of the ground bus.

The interior ring ground conductor shall never be painted and must be run exposed so that visual inspection of the system may be made, and any point is available for bonding. Routing of a conductor through PVC conduit for purpose of support should be avoided for these reasons.

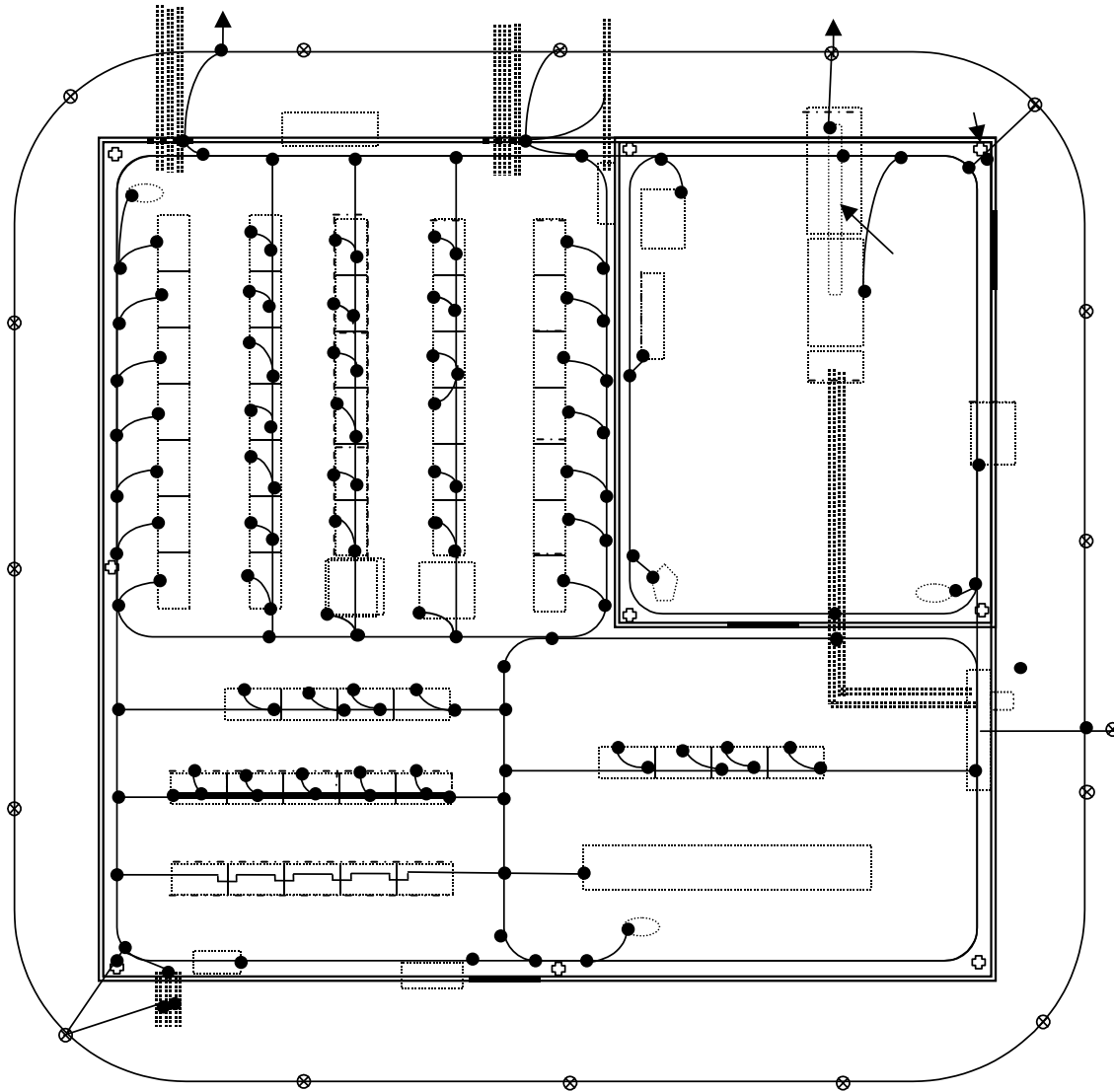

Notes:

- | | | | |
|--------|---|--------|--------------------------------------|
| 1. ⊗ | Driven Rod | 2. — | # 2 AWG Wire |
| 3. —●— | Exothermic Weld or Crimp | 4. —●— | # 6 Ground Connection |
| 5. —○— | 8" min. radius bend in wire | 6. | For Wall Supports see Fig. 7-12 |
| 7. | For Crimp Connections see Fig. 7-13 | 8. | For Cable Rack Support see Pub 77351 |
| 9. | For Conduit Bonds see Fig. 7-9 | 10. | For Hatch Plate Bonds see Figs. 7-7, |
| 11. | For Framing Channel Support see Fig. 7-15 | | 7-8, and 7-10 |

Figure 7-11: Typical Ring Ground Installation in a Microwave Station

7.14 Forming and Support of Supplementary Buses

Supplementary buses are normally supported from cable rack stringers (see Figure 7-14) or framing channels furnished for support of cable racks, conduits, and similar structures. When so routed, the ring shall be bonded to the supportive unit at not more than 15 foot intervals. In order to avoid drilling of cable rack, it is recommended that supports of the type shown in Figure 7-12 SK-A be used at 2 foot intervals (although tying to the cable rack or its J or L brackets with #9 waxed cord is permissible). The spring type universal clamp, when mounted on a cable rack stringer, ensures a maintenance free bond to the cable rack (if the insulation is stripped from the cable and the clamp makes metal-to-metal contact with the conductor). The assembly supports the wire away from the rack to avoid interference from rack supporting hardware. At points of rack junction or other points of interference with the ring run, a job fashioned detail equivalent to the zinc plated steel bracket may be used to route the wire around obstructions. Removal of paint from the stringer is not required when the clamp is installed. Scratches in the finish shall not be painted, and the clamp shall not be painted.

Where cable racks are not available for support of supplementary grounding conductors, framing channel superstructure may be utilized (see Figure 7-15). Such channels shall be bonded to the wire at both ends of a bus run portion supported in this manner and at 15 foot or lesser interim intervals when the run portion exceeds 20 feet. The bond shall be made by drilling the channel and mounting a ground clamp thereon, so that the lower edge of the wire insulation is close to the bottom edge of the channel. Supplementary supports for the wire (clips), shall be provided at 2 foot intervals along the channel.

7.15 Miscellaneous Unit Bonding

Electrical and mechanical units, not classifiable as bays, cabinets, or stands, such as engine-alternator sets, fuel tanks, motor driven fans, air pressure and alarm units, dehydrators and similar units require unit bonding. Connection of the unit bond shall be made with 2-hole crimp connectors.

Units of similar nature to the above, that are associated with heating, air conditioning, personnel facilities (such as electrical toilets, including metallic partitions), protective grill-works and other metallic items furnished as part of building facilities, except such items as electric clocks or other units of relatively insignificant bulk (that are located at least 1 foot from unit bonded items) shall be unit bonded.

7.16 Conduit, Pipe and Duct Bonding

Conduits, pipes and ducts invariably are routed throughout the area bounded by the interior ring ground, and in central office installations they usually extend beyond that area into areas of a floor occupied by other types of communication equipment or building facilities. Pipes and conduits, raceways and air ducts, when joints are permanently joined by conventional means (without slip joints), are excellent electrical conductors. When these objects terminate in bonded units (e.g., cabinets, etc.) within the interior ring ground area, they may be considered to be adequately bonded by that unit bond for a distance of:

- 15 feet if electrically insulated from supportive steel hardware.
- 30 feet if metallically fastened to supportive steel hardware (e.g., high level superstructure) at intervals of less than 15 feet.
- It is recommended that conduit and pipe unit bond connectors be made using spring type conduit clips, rather than strap type clamps (see Figures 3-7 SK-A and 7-9). These clamps are spring loaded, and periodic maintenance to ensure a tight connection is not required. The clips and recommended methods of terminating unit bonds thereon may be used on conduits and pipes from 1/2 inch size to 2 inch size.
- Points of discontinuity in conduit, raceway, pipe and duct runs must be made electrically continuous by bonding across points of discontinuity with No. 6 stranded conductor with crimp lugs on the outside surface of the unit being bonded, utilizing spring type conduit clips, self tapping screws, nuts and bolts or equivalent methods of obtaining reliable continuity between the unit and connectors.
- Fluorescent lighting system fixtures and interconnecting conduit installed in frame lines within the ring ground system area shall be considered as conduit runs. Unit bonds therefrom shall be provided in accordance with requirements outlined above for conduits. Additionally, an AC equipment ground conductor shall be furnished in conduit runs and terminated in the fixture under the ballast mounting screw.
- When a ring ground system serves radio equipment in a portion of a floor and conduits, pipes, ducts, or similar units supported above the radio bays are run continuously from the radio area into other areas of the floor, each such unit shall be bonded to the peripheral bus at the exit point from the ring ground system area.

7.17 Bonding of Units Outside the Ring Ground Periphery

Electrical units of communication systems other than the radio system that may be installed on the same floor are considered to be adequately protected from lightning damage by the CO GRD and framework bonding arrangements provided for such systems. Such electrical units that are located outside the area but within 6 feet of ring buses, or of units located in the area, shall be unit bonded to the interior ring ground so that ground system continuity exists between the CO GRD and ring ground systems' components. (An exception to this requirement would be "isolated" ground plane units. Do not bond isolated ground plane framework to the ring ground.) Such bonds may be direct unit bonds; or where a number of unit bonds are required, such as when a number of frame lines terminate within bonding range of radio frame lines, a supplementary bus may be employed with individual unit bonds extended to the points of closest proximity to radio area equipment. Unit bonds shall be terminated at the point on the unit that serves as the framework ground point for the CO GRD system so as to ensure optimum continuity between the radio ring ground and framework ground systems. A frame line that runs parallel to the perimeter of a ring ground system and within 6 feet of components or units bonded to the ring ground system shall be bonded to both ends of the line. If the bond path via the frame line ground continuity device between points of unit bond connections at the interior ring ground exceeds approximately 60 feet, it is recommended that an additional bond at the approximate midpoint of the frame line be provided.

7.18 Building Structural Member Bonding Requirements

The large variety of building construction methods used requires that individual studies be made to determine bonding requirements (of the structural members to the interior ring bus) for each structure.

Spark-over between points of discontinuity or between structural metal and units installed in the building can cause structural damage or hazard to personnel. As an example, close proximity of concrete encased structural metal to a wall mounted unit may cause an explosion of the intervening concrete if the potential difference becomes great enough to overcome the insulating properties of the concrete, permitting an arc to develop.

A central office building of steel frame or reinforced concrete construction is considered to be inherently self-protective and adequate equalization of potential between structural members and the ring ground system is assumed when the ring ground system is bonded to the building CO GRD system for continuity to earth. Small buildings, such as auxiliary microwave repeater stations or small remote central offices, afford a higher concentration of current through fewer paths and, dependent on construction features, deliberate bonding to ensure voltage equalizing is required.

General construction features normally encountered are listed below:

Walls

- Concrete block
- Brick veneer, concrete block
- Reinforced concrete
- Precast reinforced concrete panels

Columns

- Concrete block
- Reinforced concrete
- Steel section in concrete
- Steel section or pipe, exposed

Roof Beams

- Steel beams or fabricated metal
- Prestressed reinforced concrete
- Reinforced concrete
- Metal framed opening in walls and roofs

Metal framed openings in walls, such as door frames (bucks), air intake and exhaust openings, engine exhaust thimbles, etc., may or may not be grounded through continuity extended by rebars, hoods or other metallic objects from bonds connected to the exterior ring bus. Such frames shall be bonded to the peripheral ring bus, regardless of other paths of continuity to earth, except where metallic units are coupled/bonded directly to the peripheral bus by a reliable metallic connection, such as bolting. In this respect, frames of waveguide openings, where peripheral bus is bonded to the hatchplate, need not be bonded.

Small prefabricated buildings or huts of metallic frame and exterior surface construction, mounted on a concrete pad, are often used to house radio equipment. They are usually equipped with an interior peripheral ring bus (J rail) and all unit bonds terminate thereon. The metallic structure requires no bonding other than that afforded by the bonds furnished for connection of the structure to the buried exterior ring system. If the structure rests on metallic skids, they need to be bonded to the buried exterior ring system at each end.

7.19 Telecommunications Facilities at Radio Stations

In general, telecommunications facilities at radio stations in residential, industrial, or commercial areas (i.e., not on a remote mountaintop) do not present any additional protection problems. Antennas are usually located on high buildings having steel frames that provide a good path to ground for lightning strokes. In such cases, since the possibility of dangerous current being impressed on telecommunication facilities is very remote, only the protection normally required for similar locations without radio equipment is provided. However, common grounding at the radio station is essential to limit voltage differences and high-frequency induction.

7.20 Environmental Considerations - Mountain Top Installations

Radio station installations on mountaintops are built on high resistivity topsoil over bedrock where use of the exterior ring ground with counterpoise extensions is recommended. If no external power service or communication facilities are required at such installations, the ring counterpoise will probably provide an adequate grounding electrode system. However, wire facilities are usually connected to most radio stations and to distant switching centers or power substations, often located in a valley several miles away where soil resistivity is lower than on the mountaintop. A lightning stroke to the mountain top installation under these conditions can create some serious protection problems. The greater the difference in soil resistivity between the two locations and the higher the impedance of the connection facilities, the more likely will be the need for additional protection.

7.21 Frame and Power Plant Return Bus Bonding Requirements

Every metal frame, cabinet, battery stand and individual electrical unit (e.g., engine alternator sets) located within the area bonded by the interior ring ground requires unit bonding.

Bay frame lines may not be equipped with inter-bay ground junction facilities, or they may be equipped with inter-bay junctioned copper ground busbars (e.g., relay rack ground busbars) for frame grounding. Bays equipped with interjunctioning ground devices must be individually unit bonded to a supplementary or interior ring ground. Bays interjunctioned by means of copper ground bars require connection to a ring bus at each end of the continuous ring ground run, to form the equivalent of a supplementary ring ground in which the RR GRD bus serves as part of the supplementary bus. Duct bays supported by a common pipe are not considered adequately unit grounded frames (see Section 5.8).

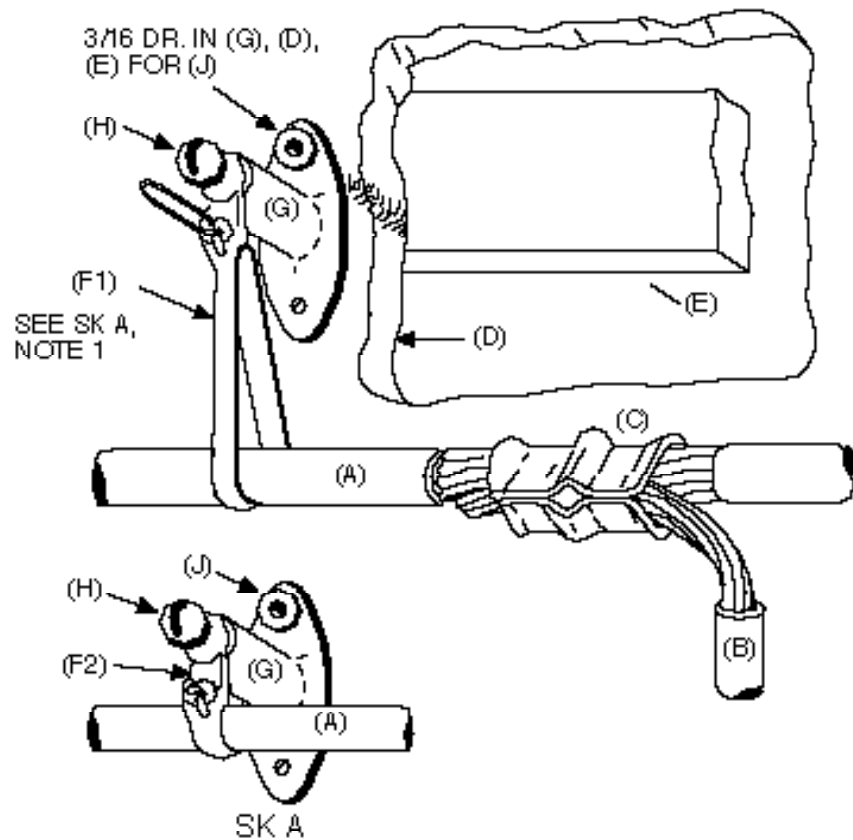

NOTE:

To facilitate crimping of wires to (A), strap (F) should be installed in position (F1) until all crimps are made, then adjusted to position (F2)

LEGEND

- (A) No. 2 AWG Stranded Copper Wire (Peripheral Bus)
- (B) No. 6 AWG Stranded Copper Wire (Unit Bond)
- (C) Crimp Type Parallel Tap
- (D) Drywall (illustrated), Concrete, Brick or Other Wall Material
- (E) 1 x 2 Fire-Rated Wood Sleeper 9'8" From the Floor
- (F) Nylon Cable Tie: (F1) in Installation Position, and (F2) in Final Position
- (G) Nylon Standoff
- (H) Fastener Screw
- (J) Nylon Fastener

Figure 7-12: Wall Support Assembly for an Interior Ring Ground

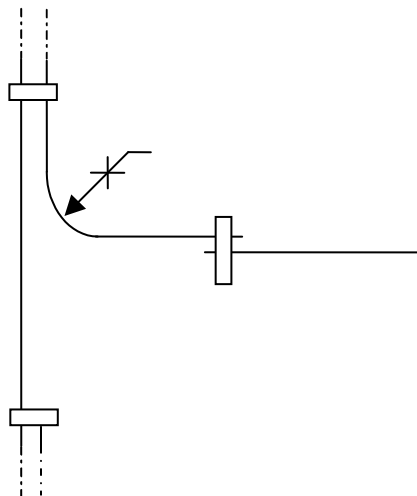
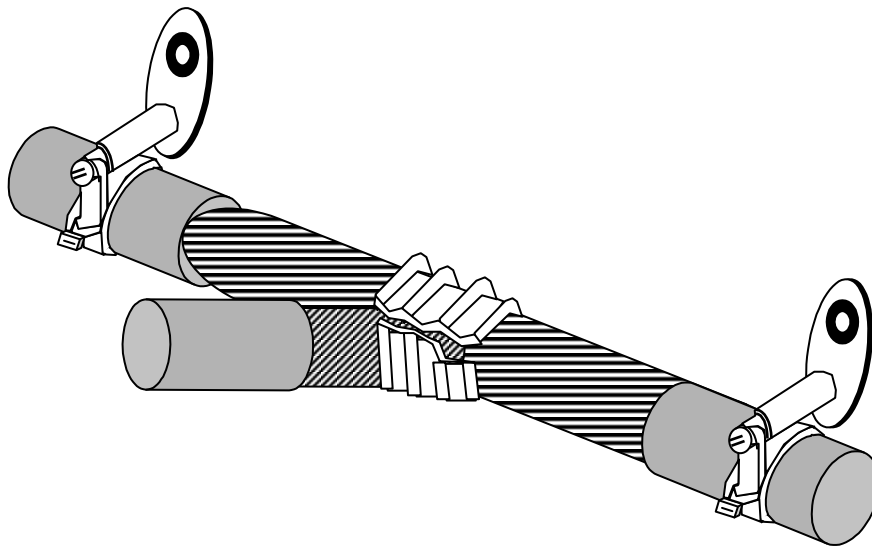
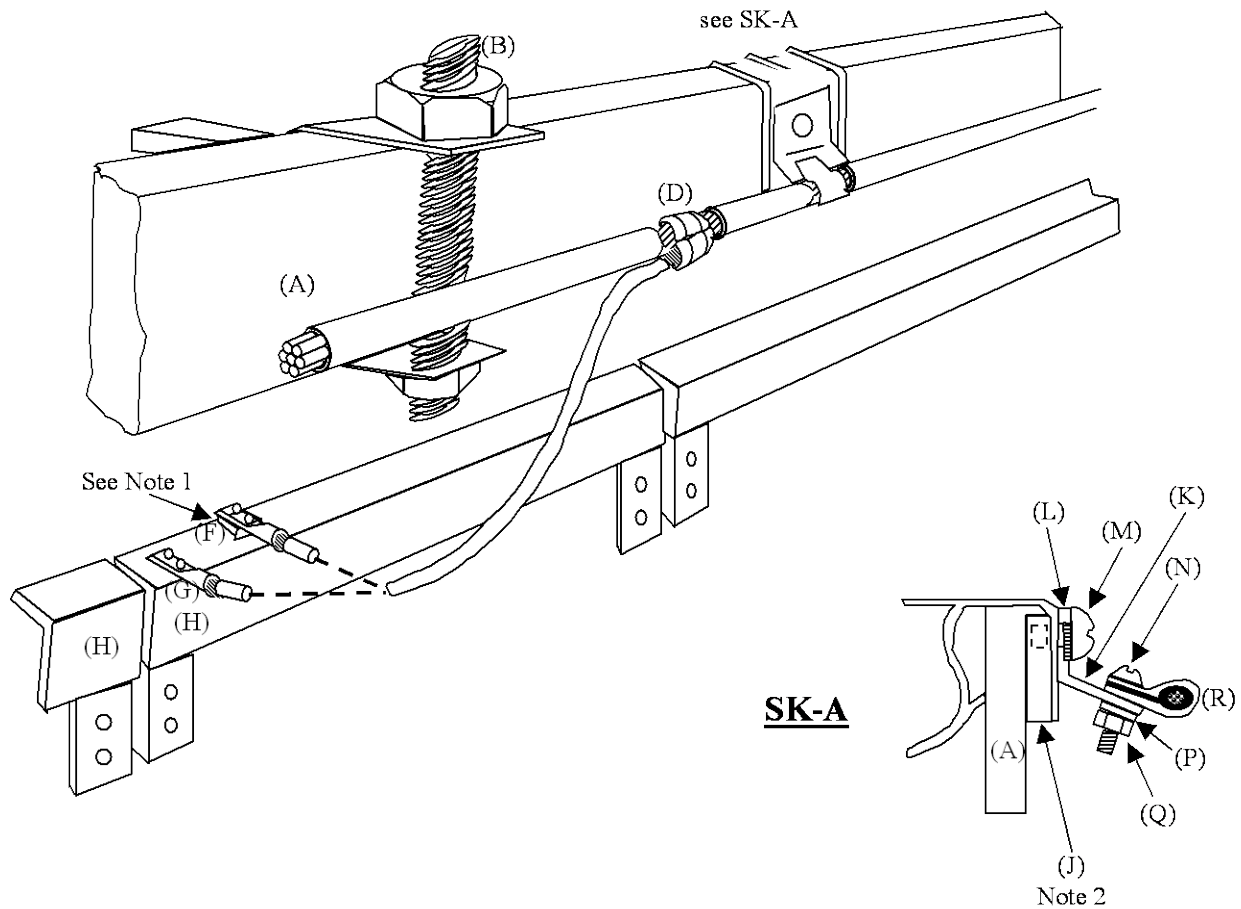

Figure 7-13: Typical Supplementary Ground Crimp Connections



LEGEND

- | | |
|--|---|
| (A) 3/8" thick cable rack stringer | (B) Cable Rack Support Hardware (typical) |
| (D) # 2 AWG THW supplementary bus wire | (D) Parallel crimp connector |
| (E) # 6 AWG green THW unit bond wire | (F) Caddy universal clamp |
| (G) 2-hole bolted tongue crimp connector | (H) Units requiring ground bonds |
| (J) Universal clamp | (K) Bracket |
| (L&P) Lockwasher | (M&N) RMM screw |
| (Q) Hexnut | (R) Steel clamp |

NOTES

- (1) (F) clamp may be used on 1/4" thick frame steel when the frame is not drilled for (G) connector
- (2) (J) clamp may be mounted on top or bottom of stringer
- (3) If (SK-A) caddy clamps are not available, C-tap (D) to a #6 AWG terminated in a 2-hole lug landing on a drilled bar

Figure 7-14: Method of Supporting Ring Bus Wire on Cable Rack and Connection of Bond Wire

The unit bonding points of frames requiring individual bonds are variable in accordance with the facilities provided with the frames. Certain frames may be equipped with ground buses located near the top of the frames but afforded with facility for interbay junctioning. The optimum unit bond point for such frames is the ground bus, when the bus is not isolated from framework metal. The optimum unit bond point for frames not equipped with ground buses is the frame metal at the top of the frames. Such frames may be shop equipped with ground lugs, or holes for mounting job furnished lugs or may have no provision for mounting ground lugs.

Two-hole bolted tongue crimp connectors are required for unit bond connections. Other type lugs must be discarded, if furnished, and replaced with crimp connectors. Where ground lugholes are not provided and a 1/4 inch thick top or upright angle is part of the framework, a universal clamp may be mounted on the 1/4 inch thick angle to avoid the effort of drilling (see Figure 7-14). A two hole bolted tongue crimp connector shall be mounted with a screw and lock-washer in the tapped hole of the clamp. When the frame construction is such that a clamp cannot be mounted, the frame shall be drilled to mount a two-hole crimp connector.

Note: Paint must be removed to provide a clean bare metal surface and an anti-oxidation compound applied to all connectors.

Relay rack type framework equipped with ground bars and inter-bay junction plates is grounded through mechanical connection of bars to frame, and inter-bonding between frames is accomplished by use of junction plates (these junction plates are an old method that is no longer acceptable on a going forward basis – each frame must have its own individual unit bond to the ring). The ground bars are considered equivalent to supplementary ring grounds. Frames of this type are considered adequately grounded for lightning protection and equipment grounding purposes when # 2 AWG supplementary ring ground conductors are extended from crimp connectors mounted on each end of the continuous ground bus. These conductors are run to the interior ground or other supplementary ring grounds (see Figure 7-11).

Electrical apparatus cabinets, such as AC service distribution, control, lighting, and similar metallic cabinets, shall be unit bonded to nearby ring ground buses. Termination of the unit bond shall be made with two-hole crimp lugs on the exterior surface of the cabinet. Nonelectrical metal cabinets such as tool cabinets mounted within 6 feet of units requiring unit bonding, shall also be bonded to the ring ground system.

Metal battery stands and similarly constructed metallic units shall be bonded to the ring ground system. Connection, utilizing two-hole crimp lugs, shall be made to the stand body or upright that affords shortest inter-unit bonding path to neighboring structures. Some of these units are long enough that additional unit bonds may be required to maintain low impedance path. (Individual structures shall not be directly interconnected.)

The return bus of all power plants must be referenced to earth. The size of the reference conductor is dependent on the power plant and site size. In COs, this reference conductor is run from the return bus to the COGB (or the MGB in the case of a plant serving an isolated ground plane with a remote ground window). However, many radio sites do not have a COGB (they have an interior ring). In a radio site, a 1/0 AWG (although a No. 2 will suffice) ground reference between the power plant return bus and the interior ring or OPGPB is sufficient.

7.22 Power Service

Radio station equipment and tower obstruction lighting are vulnerable to damage from lightning surges and switching transients originating on the connecting power facilities. Rectifiers and other equipment employing semiconductor components are particularly susceptible to damage from extraneous potentials originating on commercial power facilities. To prevent such damage, protective devices should be used on entrance service conductors and on branch power circuits, which exit the building (see paragraph 7.7).

Protective devices for limiting abnormal surge and transient voltages on power circuits function by discharging longitudinal surge current on a phase conductor either to ground or to neutral. It is desirable from an identification standpoint to use the term "arrester" in identifying power circuit protective devices to distinguish them from protectors associated with communication circuits. Note that the use of the term "arrester" here actually refers to a device rated both as a surge arrester and a transient voltage surge suppressor / surge protective device (TVSS or SPD), per NEC Articles 280 and 285.

At installations where bonding and grounding have been provided as recommended in this publication, the possibility of damage to station equipment from lightning strokes to the antennas and supporting structures is minimal; however, equipment powered from external power facilities is susceptible to damage from overvoltage surges originating on such facilities. In addition, lamp burnout in tower lighting primarily results from such surges. Tower wiring must be installed in metallic conduit.

Protection against hazardous surge voltages in power utilization circuits requires a systemic approach, starting with protection on the primary distribution circuit and ending with adequately protecting the station distribution transformer. This approach involves a variety of devices and arrangements dependent on the number of phases and type of secondary services and voltage. Primary circuit arrester grounds and the secondary neutral grounds should be solidly interconnected. This arrangement minimizes large voltage differences between primary and secondary winding of the transformer. Some electric companies prefer to have separate grounds for the primary circuit arresters and the secondary neutral, in which case, the electric company will not want a solid interconnection.

A commercially available spark gap must be installed by the power company to isolate the grounds at normal operating potentials while providing momentary interconnection for lightning surges.

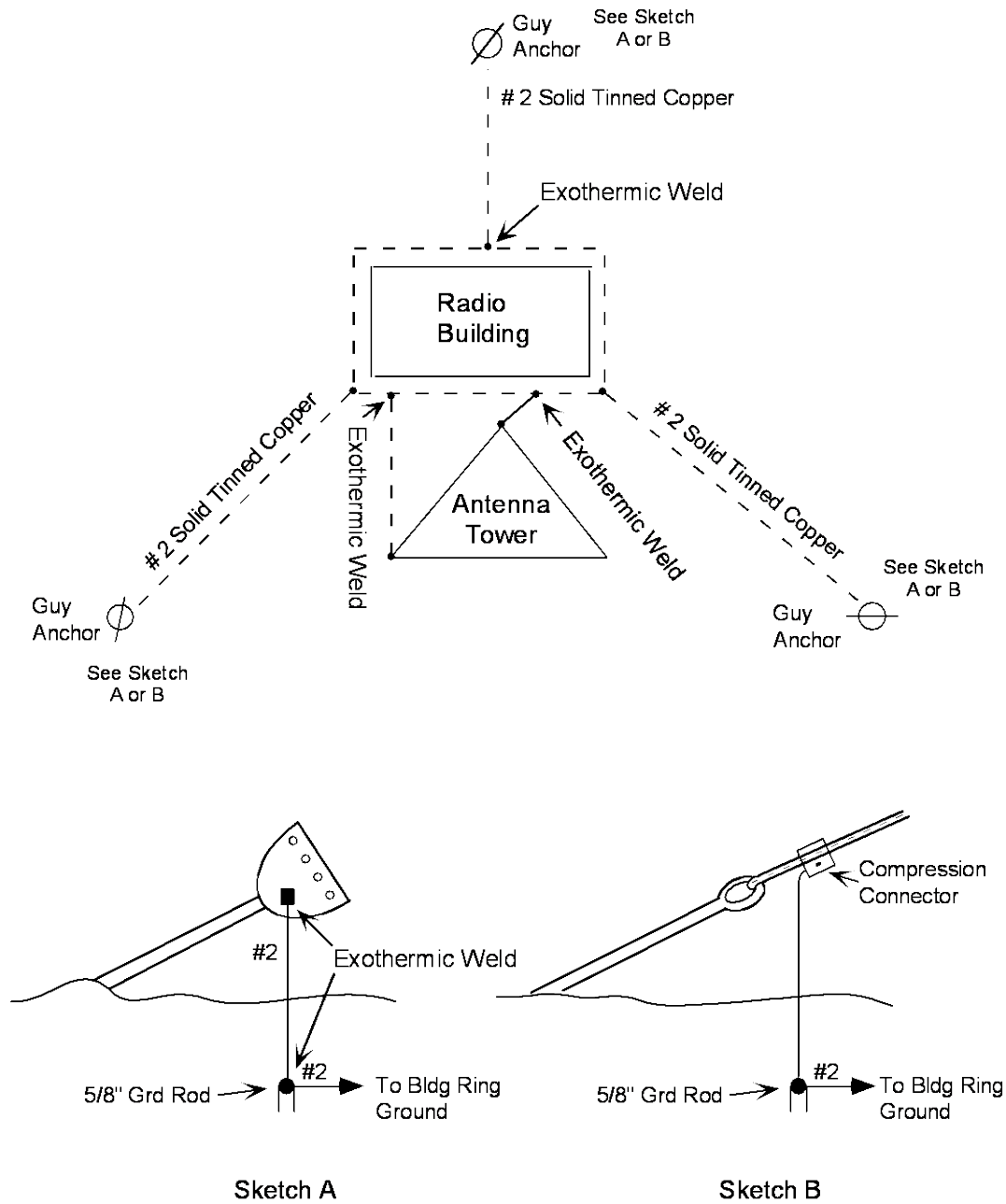

Figure 7-16: Typical Grounding of Antenna Tower Guy Wires

7.23 Grounding Issues Related to Cellular/PCS or WiMax Antennas, or Collocated Microwave Dishes

Wireless PCS/cellular (and in some cases WiMax, or other) antennas are now found at some CenturyLink locations. Many are located in high lightning areas and are prone to lightning damage, both from direct and indirect lightning strikes. Improper lightning protection can cause equipment damage, service outages, and personnel injury. In addition, CenturyLink often places higher speed fiber backhaul services with a metallic drop (such as DS-3 over coax, and 10/100 BaseT or GigE on Cat5 or Cat6 ethernet cabling) at wireless carrier locations.

Some sample drawings reflecting wireless base station and antenna grounding, as well as the interfaces between the wireless and CenturyLink equipment, are shown on the following pages. The different sample figures are primarily provided to show a few of the many configurations that might be found at an existing CO where someone wants to collocate external Wireless equipment.

7.23.1 Lightning Protection for Wireless Antennas

Antenna monopoles make excellent air terminals and tend to provide an attractive strike attachment point. A tall antenna monopole may alter local strike density.

The first line of defense against lightning damages and personal injury is a correctly engineered/installed lightning protection system. This should include air terminals, downleaders, grounding electrode(s), equipotential bonding, and electrical transient protection for AC Power and data lines.

NFPA 780 provides the guidelines for the correct engineering and installation of a lightning protection system. Figures 7-19, 7-20, and 7-25 hint at some requirements of a proper lightning protection system. (Note that building or tower structural members may be used as air terminals and downleaders in accordance with NFPA 780. However, it is much more preferable to not bring lightning into the building. If there is a roof ground system in accordance with NFPA 780, it should be used instead of bringing conductors into the building [see Figures 7-19 and 7-20]. The tower, etc. should be bonded to the roof grounding system. This system then has downleaders external to the building to carry any lightning directly to ground without passing it through the building.)

This lightning protection system is tied to an approved ground electrode field, as specified in Chapter 3. Figures 7-17, 7-18, and 7-21 through 7-24 all show a ring ground for the wireless equipment, but any other approved ground system will suffice. In addition to the ring ground, a counterpoise system attached to it may be desirable. This will allow for better dissipation of lightning and transient currents and voltages away from the site electronic equipment. It will also limit ground potential rise in the direction of the electronic equipment structures (thereby limiting voltages and currents that can be induced in nearby metallic objects at the site).

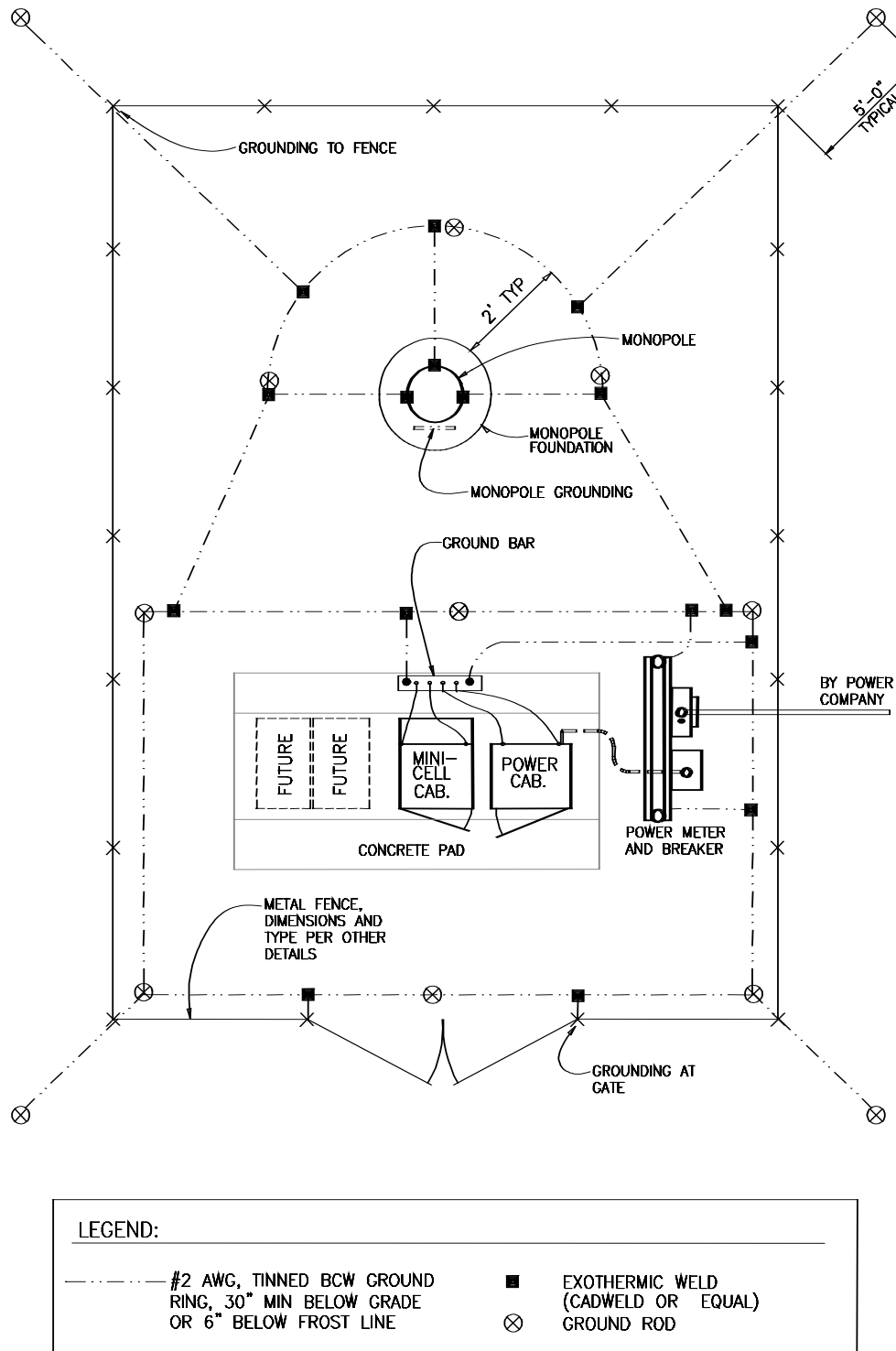
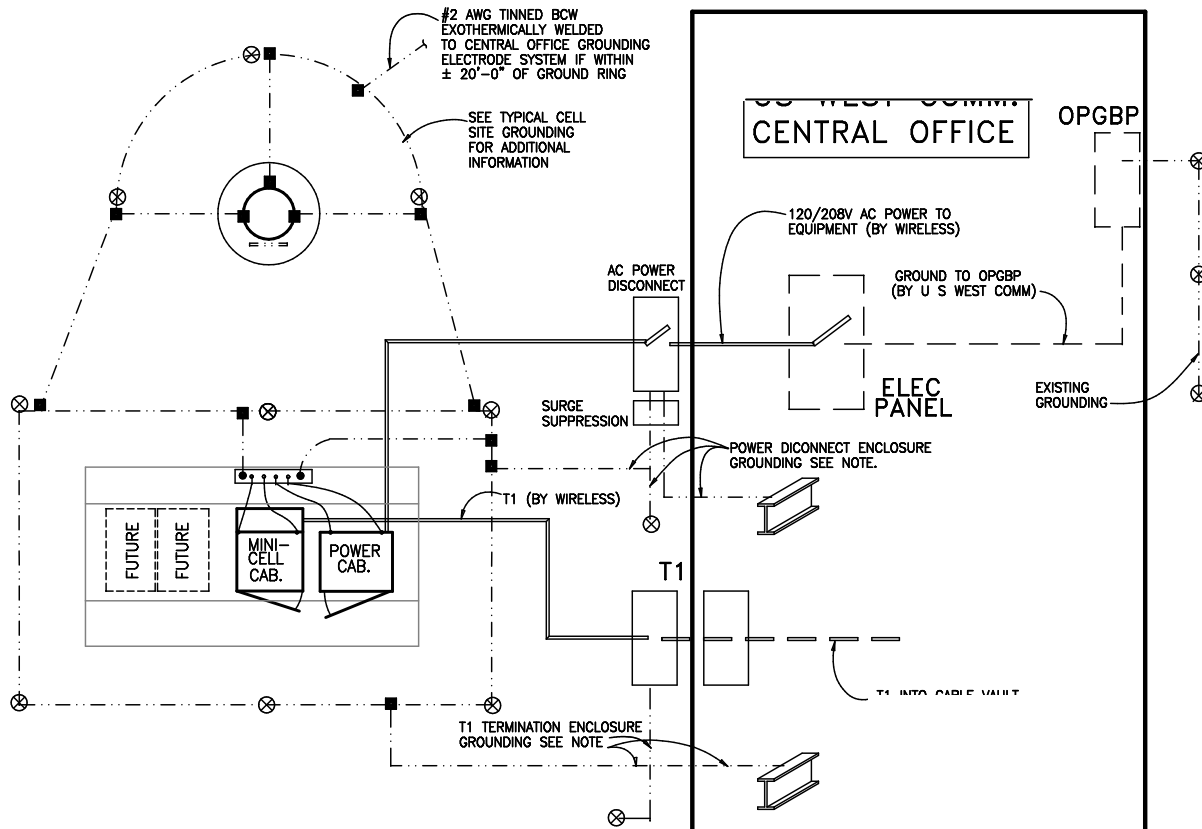

Figure 7-17: Grounding of a Typical Wireless Pole Site with a Metal Fence



T1 TERMINATION BOX GROUNDING & POWER DISCONNECT BOX GROUNDING

T1 TERMINATION ENCLOSURE GROUNDING AND POWER DISCONNECT ENCLOSURE GROUNDING ARE SITE SPECIFIC, BELOW ARE THE REQUIREMENTS FOR GROUNDING.

- GROUND WITH #2 AWG BCW TINNED TO CELL SITE GROUND RING.
- GROUND WITH #2 AWG BCW TINNED TO BUILDING STEEL IF BUILDING IS OF STEEL FRAME CONSTRUCTION AND WITHIN $\pm 15'-0"$ OF DISCONNECT ENCLOSURE
- ADD ADDITIONAL GROUND ROD ADJACENT TO DISCONNECT ENCLOSURE IF EQUIPMENT GROUND RING IS $\pm 20'-0"$ FROM DISCONNECT ENCLOSURE

NOTE: WHEN T1 TERMINATION AND POWER DISCONNECT BOXES ARE CLOSE, COMBINED GROUNDING MAY BE USED.
SURGE SUPPRESSION REQUIRED AT EACH DISCONNECT ENCLOSURE.

Figure 7-18: Grounding Interface between a Typical Wireless Pole Site and a CO

7.23.2 Tying the CenturyLink and Wireless Ground Electrode Fields Together

During a lightning strike, the lightning protection system can rise to extremely high voltage potentials relative to nearby remotely grounded objects. Bonding components of the lightning protection system to nearby grounded metallic objects tends to equalize potentials, and prevent hazards from step and touch potentials and flashover

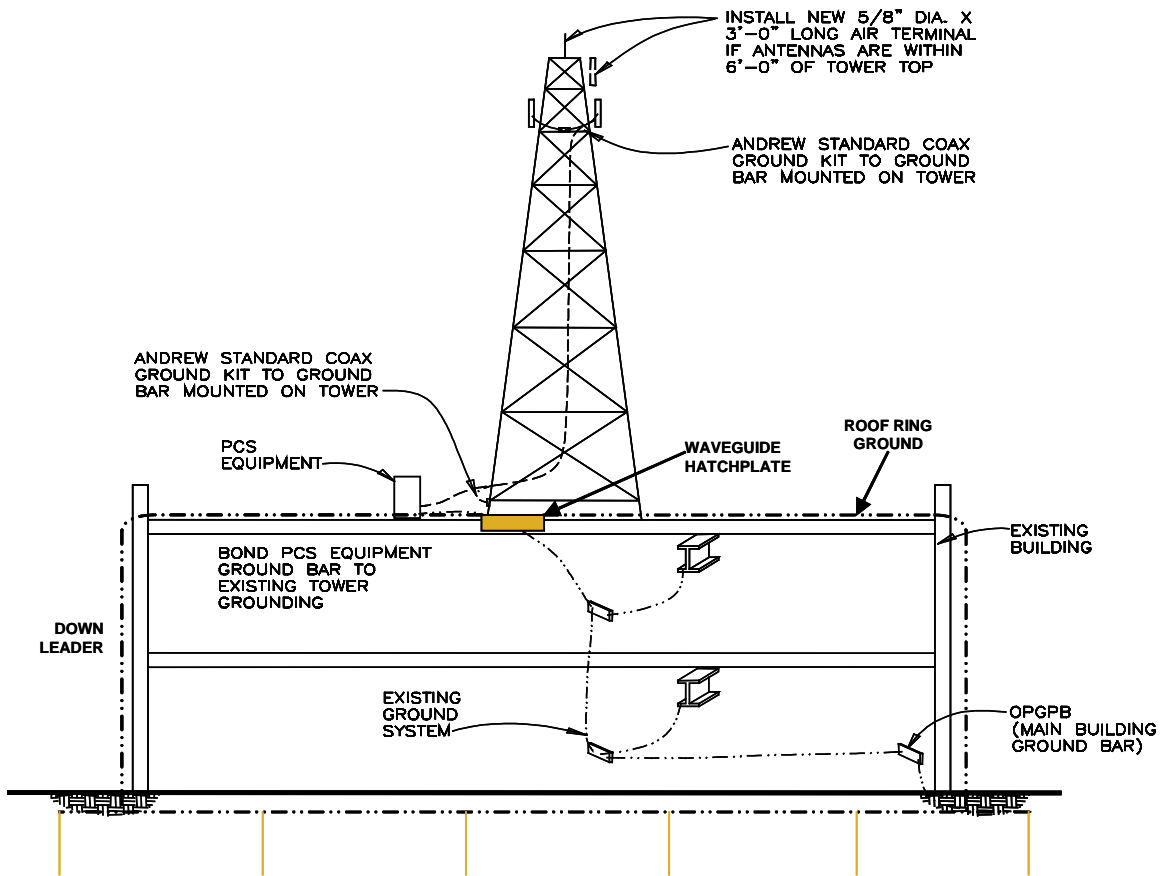

NOTES

1. The metal tower is grounded to a roof ring ground lightning protection system (NFPA 780 compliant), which is connected to an earth ground electrode field by downleaders coming down the side of the building
2. The cable from the tower enters through a waveguide hatchplate on the roof or side of the building, which is then bonded (directly or indirectly) to an external ground electrode field; and on the inside to the nearest COGB
3. There is a lightning arrestor at the waveguide hatchplate, bonded to the hatchplate or its associated ground bar
4. The roof waveguide hatchplate is bonded directly to the roof ring ground

Figure 7-19: Grounding of Wireless Equipment Mounted to an Existing Roof Tower

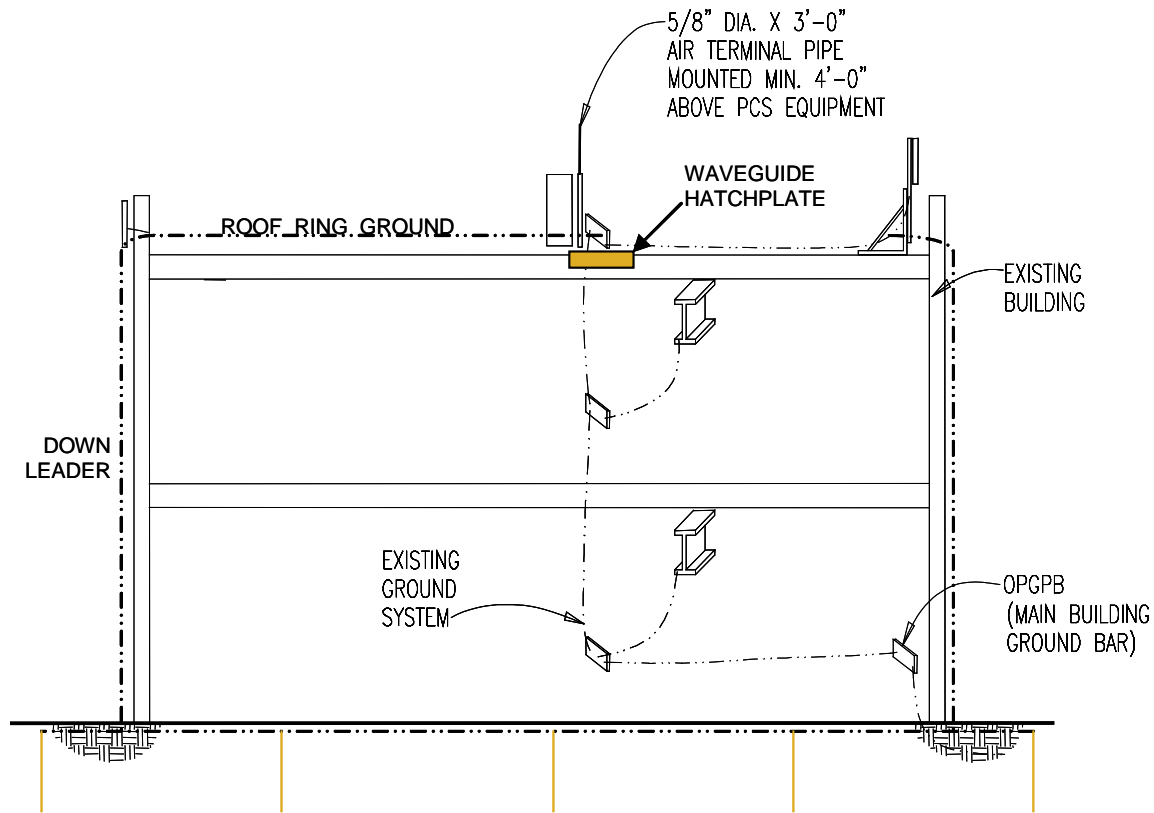

NOTES

1. If there are taller structures on the roof, there will be a roof ring ground lightning protection system (NFPA 780 compliant), which is connected to an earth ground electrode field by downleaders coming down the side of the building
2. The cable from the tower enters through a waveguide hatchplate on the roof or side of the building, which is then bonded (directly or indirectly) to an external ground electrode field; and on the inside to the nearest COGB
3. There is a lightning arrestor at the waveguide hatchplate, bonded to the plate or its associated groundbar
4. If there is a roof ring ground system, any roof waveguide hatchplate, as well as the antenna support will be grounded to it

Figure 7-20: Typical Grounding of Wireless Equipment Mounted on a Building Roof

The key to whether ground systems must be tied together relates to whether humans can simultaneously contact two ground potentials that would be produced on the separate systems during a fault or lightning strike if the systems were not tied together. Similar to isolated and integrated ground planes within a building, the key is a greater than 6 foot separation between metallic objects in the separate planes because this is essentially greater than the limit of normal human “reach” (a human can stretch their arms further than this, but that requires effort), and is in keeping with intersystem bonding requirements in various Codes (such as the NESC).

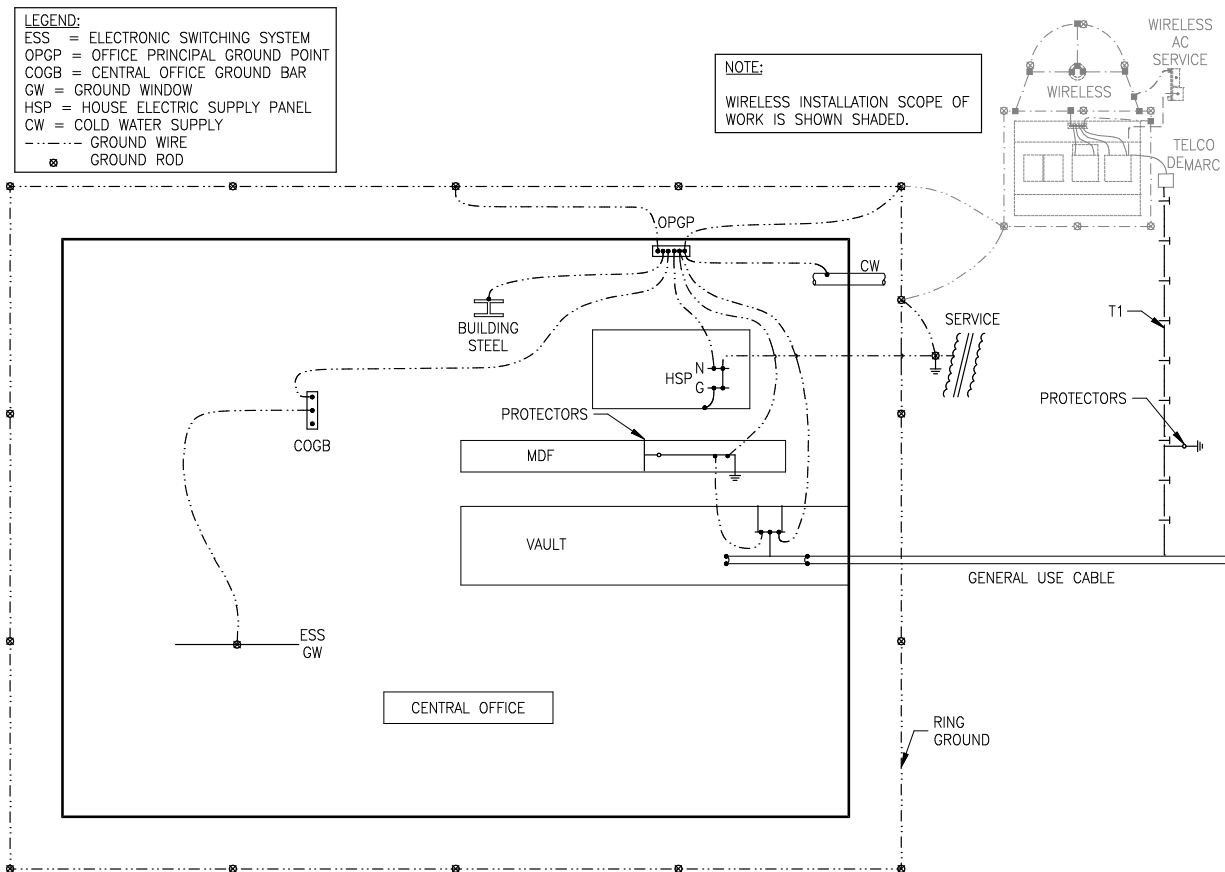

Figure 7-21: Ideal Grounding Interface Between the Ground Electrode Field of a Wireless Site and a CenturyLink CO Ring Ground

Besides the general metal objects (such as building beams, wireless site fences, etc.), there may be up to two other metallic connections between the wireless equipment and the CenturyLink CO / equipment enclosure. If the wireless carrier equipment and the CenturyLink equipment receive AC power from the same service meter, the two ground systems must be bonded together regardless of distance (“shared AC service” is covered in greater detail in Section 7.23.4). The other metal connection may be a T1/HDSL copper interface, a DS-3 coax cable, or a Cat5/Cat6 ethernet cable carrying 10/100Base-T or GigE between the wireless provider and the CenturyLink CO / equipment enclosure (used by the wireless carrier for transport). Separation between the ground fields can be obtained by gas tube protectors (see Section 7.23.5 for further detail). If the wireless carrier equipment has its own “AC Service” completely separate from the CenturyLink AC service, and all of its metal (excepting any metallic T-1/HDSL/DS-3/ethernet connection) is greater than 6 feet from any metal object related to the CenturyLink equipment, no connection between the ground fields is needed; and in fact is somewhat undesirable.

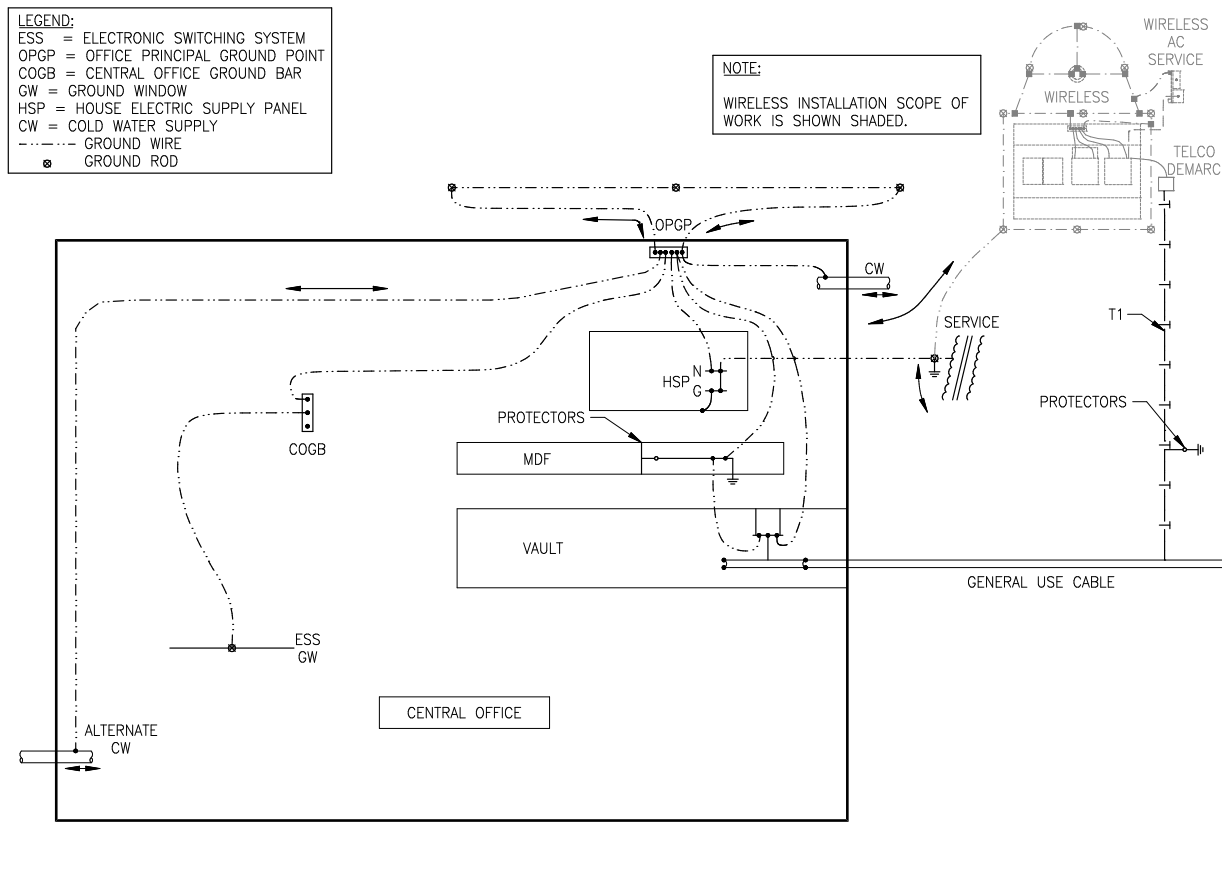

Figure 7-22: Grounding Interface Between the Ground Electrode Field of a Wireless Site and a CenturyLink CO Using a Deep Driven Rod, Counterpoise, or Chemical Ground (Ground Well) System

The wireless monopole or antenna lightning protection system is typically tied to a ground ring (or similar ground electrode system) at its base (see Figures 7-17, 7-19, and 7-20). The wireless ground electrode system also needs to be bonded at two places with the other nearby (within 6 feet) metal (which is all tied to the site ground electrode system) when there is the potential for touching of both systems at the same time. This is easily accomplished by bonding the ground electrode systems together (preferably external to any building). Nearby metal (within 6 feet) between that is not tied to one of the ground electrode systems should be referenced to it. (See Figure 7-17 for an example of how these ground electrode systems should be tied together when there is 6 feet or less of separation between the wireless Ground plane and the CO ground plane. See Figure 7-24 for an example of how these systems must be tied together, regardless of distance, when the Wireless equipment receives its AC power from the CO. And see Figures 7-21 through 7-23 for examples of how the systems don't have to be tied together when there is greater than 6 feet of separation between the ground systems.)

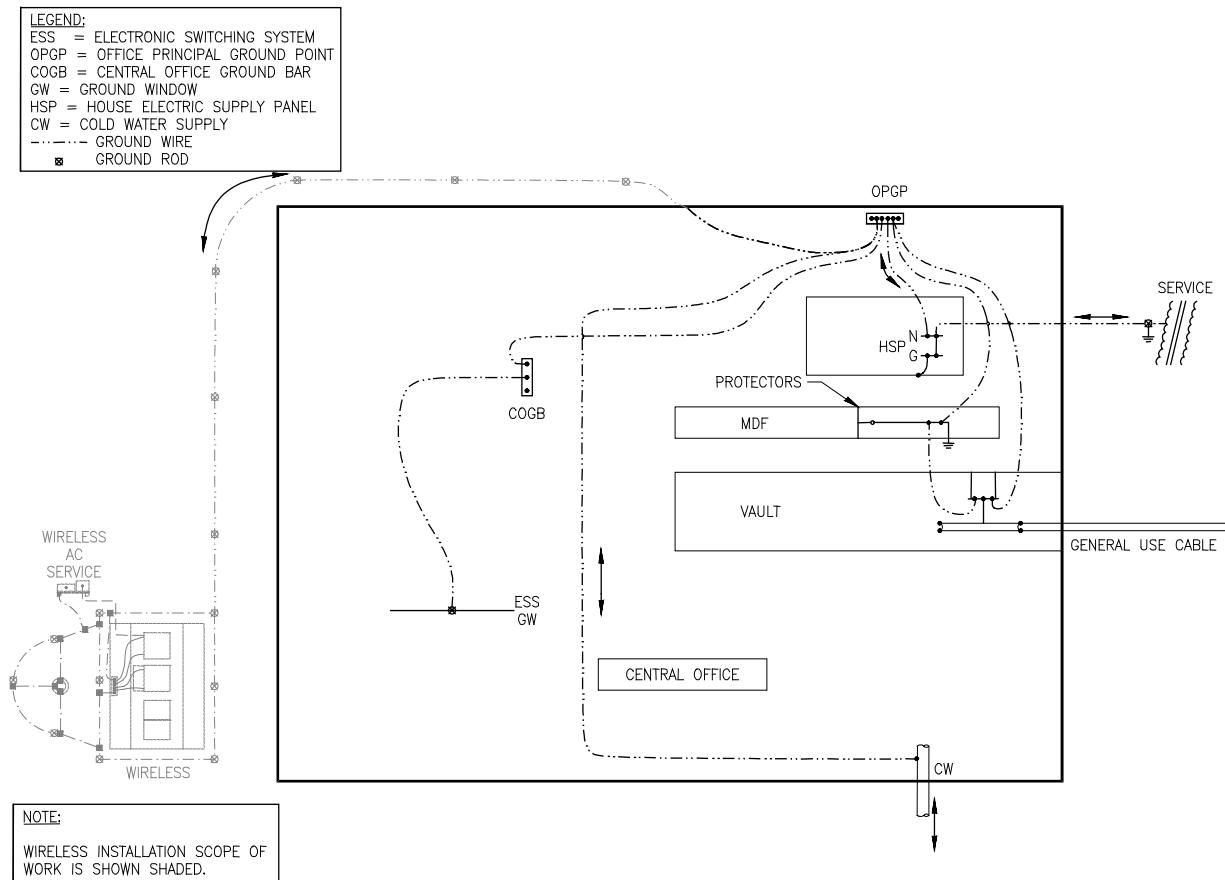

Figure 7-23: Grounding Interface Between the Ground Electrode Field of a Wireless Site and a CenturyLink CO that only has the Power Company MGN as a Ground Electrode Field

The existing grounding electrode system for the CenturyLink CO or cabinet can be any of several types discussed in Chapter 3. All are acceptable, although ground rings are preferred. Because the wireless equipment is likely to have a good ground ring, with low impedance to earth, in some cases its impedance may be lower than that of the CenturyLink building or cabinet ground electrode field. Or the opposite case may also be true. This poses a particular problem when wireless equipment, the OPGB, the cable entrance and the AC service entrance aren't located near each other, because lightning hitting one of these components may choose to take a path through the building to get to the best ground electrode field. Figure 7-21 represents the ideal situation (everything important to grounding is near each other). When this situation isn't possible, the guidelines of these sections and the other documents previously mentioned must be followed to avoid potential problems. In some cases, the Electrical Protection Engineer may specify upgrades to the Building Ground Electrode System in order to rectify potential interface problems.

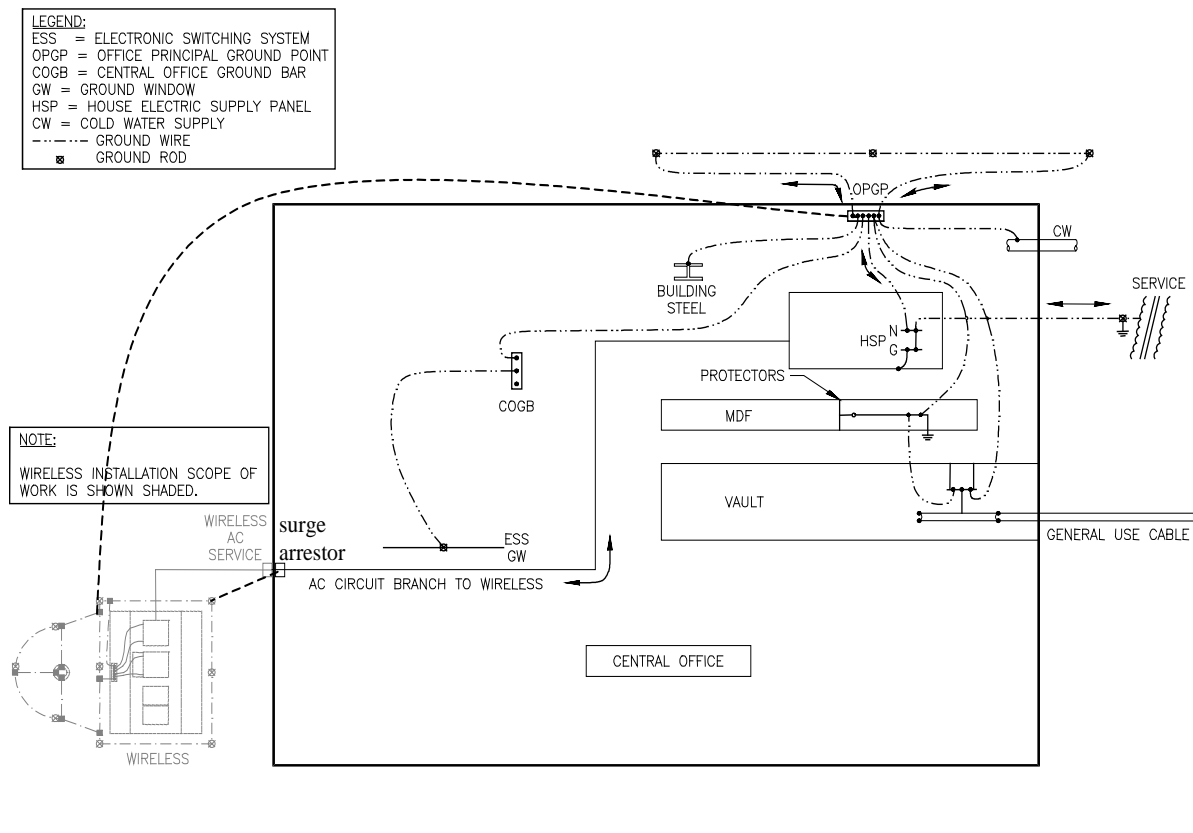

Figure 7-24: Grounding Interface Between a Wireless Site and a CenturyLink CO where CenturyLink is Providing the AC Power from Within their Building

The Wireless provider is responsible for their own grounding electrode system, any bonding to the CenturyLink and/or Power company's grounding electrode system(s) [although this responsibility may be jointly worked out with the CenturyLink engineers], and the "protection" external to the CenturyLink building or cabinet of any interconnects that they may have to CenturyLink (e.g., T1, AC feed, etc.). "External to the building" includes rooftops, as illustrated in Figures 7-19 and 7-20. For example, if placement of a PCS antenna on a building roof requires installation of certain elements of a lightning protection system (such as air terminals, downleaders, etc.), those additions are the responsibility of the wireless provider. CenturyLink is responsible for its own building or cabinet ground electrode system and any protection and/or grounding internal to the CenturyLink building or cabinet (when the wireless carrier owns the cabinet in which CenturyLink is collocating its backhaul equipment, refer to Tech Pub 77419 for responsibilities).

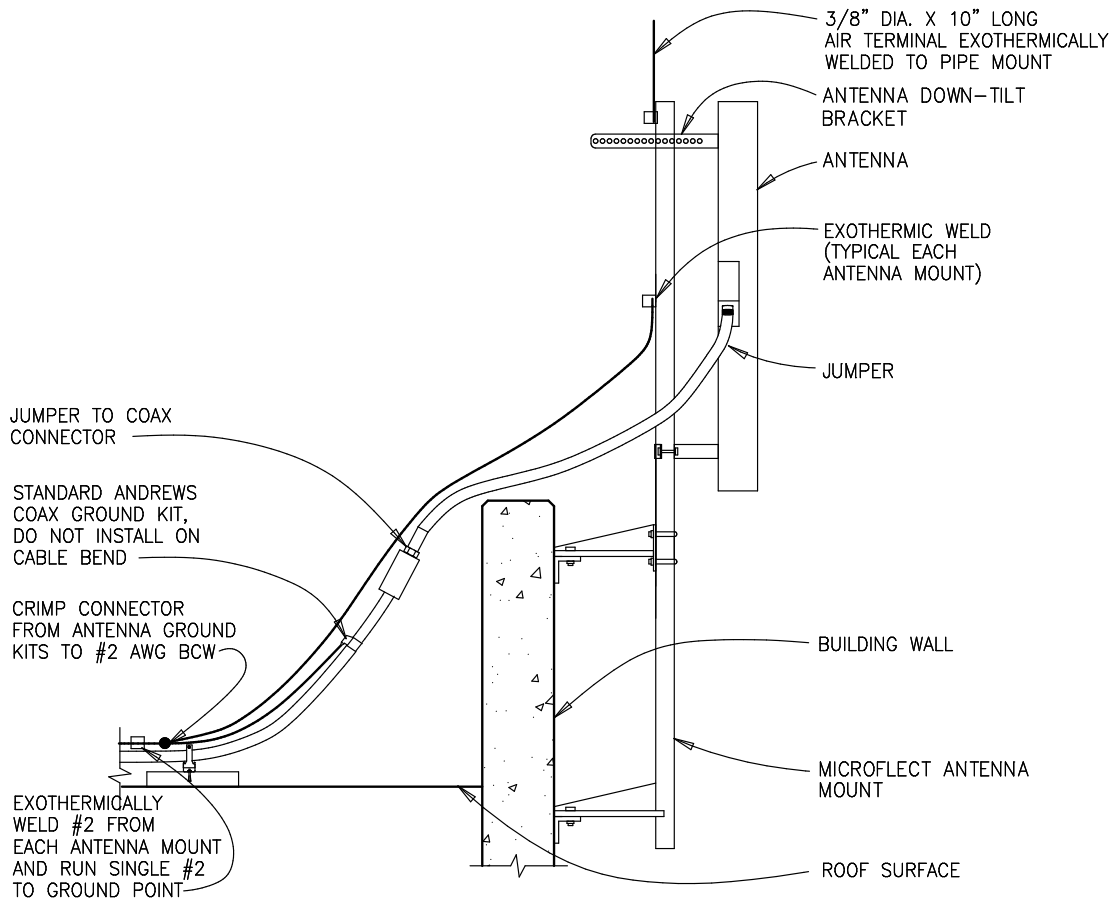

Figure 7-25: Wireless Pole Mounted Antenna Grounding Details

7.23.3 Power Service Entrance Protection for Wireless Equipment

Because Lightning is likely to strike the antenna tower or monopole, the likelihood exists that lightning can get into the AC service (either for the building/cabinet or for the wireless equipment). Proper Transient Voltage Surge Suppression (TVSS) equipment installed on the AC Service Entrance will prevent excessive lightning voltages and currents from entering the equipment through the commercial AC.

AC Power for wireless carrier equipment can be stand-alone (their own metered service), as exemplified in Figures 7-17, 7-18, and 7-21 through 7-23, or it can be supplied from a co-located or shared AC power distribution system, as shown in Figure 7-24.

Transient protection must be provided to prevent lightning or other surges from reaching the wireless equipment through the AC lines. For stand-alone AC power supplies, the service entrance should be equipped with transverse TVSS devices. For a shared AC power distribution system (reference Figure 7-24) additional TVSS devices need to be installed within 5 feet (typically at the Service Disconnect) of where the AC source enters the wireless equipment (including backhaul cabinets/enclosures) that is external to the building. In these cases, both transverse and common mode TVSS should be provided.

When nominal 24 or 48 VDC power is run between structures in a wireless backhaul scenario (this may be desirable in order to ensure that the backhaul has the same reserve time as the wireless equipment), DC surge arrestors are usually needed on both ends of the feed(s).

Wireless equipment located internal to the CenturyLink building is fed from building AC, and protected and grounded according to the practices specified in the rest of this Publication.

The AC Service Entrance grounding electrode must be bonded to the wireless ground electrode system as shown in Figures 7-17, 7-18, and 7-21 through 7-23. Where CenturyLink provides the AC power from within its building, that bond has essentially already been made internal to the building (between the HSP and the OPGP) in keeping with the requirements of Chapter 4 (see Figure 7-24).

7.23.4 Protection for a Power Interface Between CenturyLink and a Wireless Provider

When CenturyLink provides the power to the external Wireless provider, special precautions should be taken in addition to those mentioned in the previous subsection. Of particular concern is the ability of the AC or DC cable to bring lightning into the structure. Even with TVSS at the wireless equipment, it may be advisable to install additional TVSS at the point the AC service leaves/enters the CenturyLink structure.

Cable routing through a CO is also a concern. If lightning does enter the building on an AC feed going to outdoor wireless equipment, we don't want to give it easy points to jump off (flash over) into sensitive equipment. If possible, The AC feed (and any grounding conductors) leaving the building should take the path out of the building from the AC Service Entrance that passes the least amount of equipment, even if this means that more of the AC is run outside the building than inside.

Figures 7-18 and 7-24 are poor examples of AC cable routing. It would have been better to bring the AC service directly from the House Service Panel or other nearby AC panel (towards the upper right of Figure 7-24), leave the building at that point, and then run the rest of the AC service outside. While this is not always possible, it should be done whenever possible. If AC routing through the office cannot be avoided, attempt to run it away from sensitive electronic equipment, especially ESS switches. If the AC service is being obtained from a sub-panel (as illustrated in Figure 7-24), try to choose a sub-panel whose feeder conduit (from the main House Service Panel) passes the least sensitive areas.

If AC service is provided by CenturyLink, as mentioned, this increases the likelihood of lightning entering the building. Because ESS switches are particularly sensitive to lightning, other surges, and/or loop currents, it is more necessary than ever that ESS Ground Windows be properly installed, sequenced, etc. per the requirements of Chapter 8.

7.23.5 Protection for other Cabling Interfaces Between CenturyLink and a Wireless Services Provider

Data lines leave and enter wireless equipment and interconnect with telecom facilities. Data lines that use copper members (such as T-1) must have electrical transient protection at the interconnect points with telecommunications outside facilities or COs. For copper facilities interconnecting a CenturyLink equipment enclosure with external wireless equipment, there are basically 4 points of protection: outside the building, at the entrance to the Wireless equipment, in the cable entrance, and at the protector blocks. Typically, all but the cable entrance protection involves protectors. These are usually of the “gas tube” type.

The wireless provider must provide their own protectors for copper interconnect facilities that enter their equipment. Often it is built right into the equipment.

Figure 7-18 illustrates that protectors must be installed on copper data circuits at a point before they enter the building or other CenturyLink structure (such as a cabinet or wall-mount box).

If the entrance into the CenturyLink CO is underground, it is preferable for the protectors to be installed before the cables enter an external manhole (the protectors can also be installed inside the manhole, although it is preferable that they be external in a pedestal) from which they come into the Cable Entrance Facility (see Figures 7-21 and 7-22). This external protection pedestal must be grounded to a ground electrode field.

Just as with any other cable with copper members, cables entering the Cable Entrance Facility (CEF) or Vault must be shield grounded as specified in Section 6 (see also Figures 7-21 and 7-22).

After leaving the CEF, the copper facilities will have a point of presence on the MDF, DSX, or Cosmic Frame. At this point they will also be protected with a “5-pin” protector.

Oftentimes, outside cabling enters through conduit. Where possible, this conduit should be non-metallic and fire-retardant and comply with the requirements of NEC Articles 362 and 800. Metallic conduit offers a path for transients to enter the building, and we do not want this, even if the conduit is properly grounded.

7.23.6 Grounding for Collocated Microwave Facilities

Collocators may collocate microwave transmission facilities on CenturyLink towers/buildings. They also may or may not collocate their wireless equipment bays inside the CenturyLink CO or radio hut. These types of collocations deserve special mention.

When the collocator mounts their microwave dishes on a CenturyLink tower/pole structure, they should tie their grounds to the same grounds that CenturyLink already has for their own equipment. The same applies for any equipment enclosure related to the dish(es) that the collocator may have outdoors.

When the collocator mounts their dishes on their own structure on a CenturyLink roof, they should bond to the roof ring ground if it exists. If it does not exist, they should run a downleader over the side of the building and tie into the CenturyLink external ground electrode field. The same applies to any equipment cabinets the collocator may place on the roof.

When a collocator places their own microwave dish supporting structure on CenturyLink property (but not on the roof), they should bond their grounding system to the CenturyLink external ground electrode field. The same applies to any equipment cabinet they may place to support their dish(es).

When the collocator interfaces their microwave dish with equipment inside the CenturyLink CO, they must come through a waveguide hatchplate and be properly bonded to that hatchplate’s grounding system as specified earlier in this chapter. If the waveguide is center conductor coax, a lightning protector must also be placed near the hatchplate and bonded to its grounding system.

When the microwave collocator places equipment inside the CenturyLink facility, it must comply with the interior supplementary ring ground requirements of section 7.12. If the equipment is in a cage, the cage itself serves as the supplementary interior ring ground.

7.24 GPS Antenna Grounding Issues

In recent years, CenturyLink has begun to install GPS antennas on many of its buildings in order to obtain very accurate, world-standard timing (synchronization) signals from the GPS (Global Positioning System) satellite constellation. Because these GPS antennas are sometimes roof-mounted, and because they are sometimes placed away from other metal objects on the roof (such as HVAC systems, other antenna towers, etc.), they may provide a convenient lightning attraction point. Figure 7-26 details a typical setup for a roof-mounted GPS antenna. (Newer GPS systems may not be roof-mounted.) If the antenna is mounted on an exterior wall below the roof-line and under the NFPA 780 cone of protection, the external ground electrode field connection is not needed nor is an in-line surge arrestor required. An in-line in-building surge arrestor is still suggested, and when used, should be simply grounded to the nearest COGB or internal wall ring ground (preferably close to the point of entrance), following the rules in this chapter. If the antenna has window access, but is mounted internal to the building, it does not need surge protection.

The short mast to which the short roof antenna is attached is sometimes metallic (in some cases, it might be plastic) and should be grounded if it is metallic (also ground any metallic parts on a plastic mast, such as a metallic base or metallic clamps). Also, the antenna itself feeds its signal into the equipment in the building via coaxial cable. The coax needs a lightning arrestor gap specifically designed for the coax application.

Attempt to place any rooftop antenna so that it is under a “cone of protection” (as defined by the NFPA 780 rolling sphere method) of a taller grounded metal object; otherwise a lightning rod nearby that provides a “cone of protection” may be necessary.

A metallic (plastic masts don't have to be grounded) antenna mast should be grounded to the building roof ground ring (this is part of the lightning protection system – see Section 7.4) if one exists (this ring is then connected to the building ground electrode field by means of downleaders). If a roof ring ground does not exist, a #2 AWG solid copper conductor can optionally be run down the side of the building (a downleader) and connected to the building ground electrode field (requirements for proper installation of downleaders is detailed elsewhere in this Chapter, and in NFPA 780). The connection to the mast may be accomplished by means of an exothermic weld (preferred), a pipe clamp, or a two-hole crimp connector bolted to the pipe (proper application of all of these methods is detailed elsewhere in this document).

On some early installations of GPS, the coax protector was located on the antenna mast. This protector could then be grounded in similar fashion as the mast. On most later installations, the coax protector is located near the building entrance point for the coax (typically a waveguide hatchplate). It is most preferable if the protector is located external to the building (to prevent lightning from ever entering the building). In this case, the protector should be grounded to the nearest hatchplate or hatchplate ground bar), or have a separate exterior lead run to the building ground electrode field (this lead should be separated during the vertical run down the side of the building from any NFPA 780 Lightning Protection System downleaders by at least 6 feet). It is also most preferable if the coax entrance is through the cable entrance facility for the site, or a waveguide hatchplate. If the protector box is mounted inside the building, it should be located as close to the coax entrance as practical. It should also be grounded to the nearest COGB, OPGPB, or CEF Ground Bar (with ground cable routing as far as possible from working equipment, and as close as possible to exterior walls). It should also have a #2 AWG solid conductor that immediately leaves the building and connects to an external ground electrode field (preferably the existing one). When the existing ground electrode field(s) cannot be located, tie the downleader from the coax protector to another existing downleader or external ground electrode conductor as close as practical to the point where that conductor enters the earth. If that cannot be done, run the new downleader on the outside of the building to a point close to the internal OPGP, go through the wall at that point, and attach to the OPGP. This will ensure that any surges brought in on this new downleader will immediately go back out to the existing ground electrode fields tied to the OPGP.

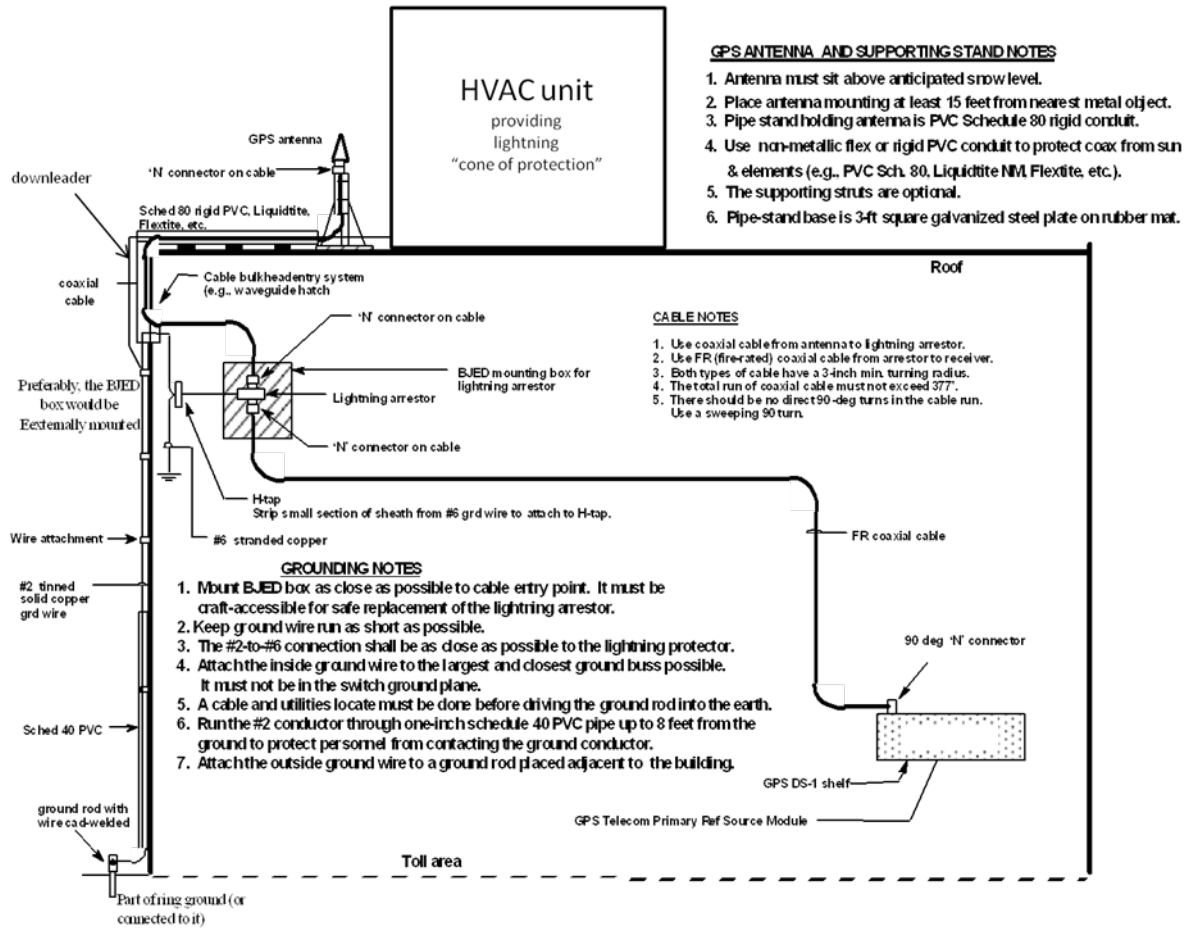

Figure 7-26: Rooftop GPS Antenna Grounding Detail

CONTENTS

Chapter and Section	Page
8. Isolated Ground	8-1
8.1 Isolated Ground Plane Principles	8-1
8.1.1 Isolated Ground Plane.....	8-1
8.1.2 Stored Program Control Frames.....	8-1
8.2 Interconnected Frames	8-2
8.3 Serial, Radial, and Mesh Grounding.....	8-2
8.4 Isolated Frame Grounding Methods.....	8-2
8.5 Power Supply Grounding Methods.....	8-6
8.6 Multigrounded Power Source.....	8-6
8.7 DC Power Supplies.....	8-6
8.8 AC Power Supplies.....	8-8
8.9 General Isolated Grounding Conductor Requirements	8-9
8.10 Induction Effects	8-10
8.10.1 Loops in the Isolated Ground Plane.....	8-10
8.10.2 Lightning and Fault Current Carrying Members.....	8-10
8.10.3 Nearby Integrated Ground Plane Frames	8-10
8.11 Isolating Ground Plane Frames (Specific Requirements)	8-11
8.11.1 Specific Requirements	8-11
8.11.2 Insulation Resistance	8-12
8.11.3 Frame to Frame Connections	8-12
8.11.4 Grounding Among Groups of Frames.....	8-14
8.11.5 Serial and Radial Connections Within the Isolated Plane.....	8-14
8.11.6 Limits on the Number of Floors an Isolated Ground Plane Can Occupy	8-14
8.11.7 Peripheral Equipment Frame Grounding	8-15
8.12 External Principal Power Plant Grounding Requirements.....	8-15
8.12.1 The Return Bus	8-15
8.12.2 Grounding the Return Bus	8-16
8.12.3 Grounding the Plant's Frame(s).....	8-16
8.12.4 Location of the Power Plant	8-16
8.12.5 Power Feeders	8-16
8.13 Integrated Ground Plane Loads.....	8-18
8.14 Loads Fed from Internal Power Sources	8-19

CONTENTS (Continued)

Chapter and Section	Page
8.15 Grounding Internal DC and AC Power Supplies Within the Isolated Ground Plane	8-19
8.16 Grounding the External AC and DC Power Supplies Feeding Isolated Ground Plane Loads (Other Than the Principal Power Source).....	8-19
8.16.1 DC Power Supplies.....	8-19
8.16.2 AC Power Supplies.....	8-19
8.16.3 Treatment of the AC Conductors	8-20
8.17 Specific Examples of AC and DC Grounding Principles for Isolated Ground Planes.....	8-20
8.18 Establishing a Ground Window	8-20
8.18.1 Dimensions	8-20
8.18.2 Location.....	8-21
8.18.3 Connections	8-21
8.19 Ground Window Configurations	8-21
8.19.1 Separate Ground Window	8-22
8.19.2 Using the Return Bus as the Ground Window	8-22
8.19.3 Requirements for Both Kinds of Plants.....	8-22
8.19.4 Requirements for Plants with an Insulated Return Bus.....	8-25
8.19.5 Requirements for Plants with a Noninsulated Return Bus.....	8-25
8.20 Methodology for Establishing an Isolated Ground Plane.....	8-25
8.21 Performance Verification and Test Procedures	8-30
8.21.1 Visual Test.....	8-30
8.21.2 External Power Supplies.....	8-31
8.21.3 Internal Power Supplies.....	8-31
8.21.4 Insulation Test	8-32
8.22 Isolated Ground Plane Noise Circuit Test.....	8-32
8.22.1 Abnormal Current Flow in Grounding Wires and Frames	8-32
8.22.2 Correctly Wired Circuit Arrangements.....	8-33
8.22.3 Correcting Improperly Wired Circuit Arrangements	8-33
8.22.4 Overvoltage Protectors.....	8-34
8.22.5 Improper Load Connections	8-34
8.23 Distributed DC Power Plants in the Isolated Ground Plane.....	8-34

CONTENTS (Continued)

Tables	Page
8-1 Tabulation of Typical Ground Window Connections	8-24
 Figures	
8-1 Simplified Isolated Ground Plane	8-3
8-2 Simplified Examples of Serial and Radial Frame Grounding	8-4
8-3 Typical Overall Frame Grounding Methods	8-7
8-4 Loops (Isolated Ground Plane)	8-13
8-5 Typical Grounding and AC Power Feed to an Isolated Ground Plane.....	8-17
8-6 Typical Sequence of Connections to a Separate Ground Window	8-23
8-7 Typical Grounding and Power Feed from a DC Power Plant Powering Isolated Ground Plane Loads.....	8-26
8-8 Grounding for Integrated and Isolated Ground Planes Powered from a Common Power Plant.....	8-27
8-9 Using an Insulated Return Bus As The Ground Window	8-28
8-10 Using a Noninsulated Return Bus As The Ground Window	8-29

8. Isolated Ground

8.1 Isolated Ground Plane Principles

8.1.1. Isolated Ground Plane

An isolated ground plane is a set of interconnected frames that is intentionally grounded by making only one connection to a given ground reference. This plane, taken as a conductive unit with all of its metallic surfaces and grounding wires bonded together, is insulated from contact with any other grounded metalwork in the building. During external fault occurrences in the AC or DC power systems and when lightning current flows in the building, none of these currents can flow in the isolated ground plane because of the single-point connection. Some users and suppliers call an "isolated ground plane" an "isolated ground zone" or an isolated bonding network" (IBN).

8.1.2 Stored Program Control Frames

Most switching equipment requires an isolated ground plane. Examples include the Lucent 5 ESS®, and the Nortel DMS® family of switches. However, other switching equipment (e.g., DACS, some ATM switches, etc.) does not require an isolated ground plane. This decision is left wholly to the switch manufacturer.

However, unless you know otherwise, you may assume that all of the frames that house a Stored Program Control Switching System (SPCSS), whether Analog and/or Digital, are normally treated as an isolated ground plane. Therefore, all references to SPCSS equipment frames shall normally assume that they are in an isolated ground plane (unless otherwise known).

Because an isolated ground plane switch manufacturer is most familiar with their switch and how to make it work properly, their own written requirements for grounding internal to the switch footprint supersede any CenturyLink requirements.

Figure 8-1 illustrates an isolated ground plane in its simplest form. A set of frames housing electronic circuits is initially insulated from all integrated ground planes. This includes building steel and all frames connected thereto. Then, a single point of connection is made through a ground window (also known as a Single-Point Connection Window or SPCW) from the electronic entity to the integrated ground plane.

When an SPCSS is treated as an isolated ground plane, external noise currents that could produce voltages, that damage and upset the system circuitry, cannot flow in the frames. Some sources of external noise currents are the following:

- Lightning strikes
- External power faults

- Filters that are connected from line to ground
- Multigrounded AC and DC power sources
- Lightning protectors connected from line to ground
- Improper load connections

8.2 Interconnected Frames

Groups of frames within an isolated ground plane may be interconnected through the use of cross-aisle interconnections that connect the frames of one frame lineup to the frames of a second frame lineup. Cross-aisle metallic cable trays, metallic power conduits, metallic cable shields, and deliberate cross-aisle bonds may be used to interconnect groups of frames within an isolated ground plane.

8.3 Serial, Radial and Mesh Grounding

Both serial (also known as Chain-IBN) and radial (also known as Star-IBN) forms of grounding in a set (or parts of a set) of frames in an isolated ground plane can be used. Judicious use of these techniques avoids the formation of loops (see Figure 8-2). Some switch manufacturers have even gone to mesh grounding within the isolated ground plane (which does create internal loops), but with a single “frame reference ground” connection back out to the ground window. This is still “single-point” or “isolated” grounding; and is within the rights of the switch manufacturer to decide how their switch shall be grounded. They know what types of noise and currents to which their switch is susceptible.

8.4 Isolated Frame Grounding Methods

Figure 8-3 illustrates the overall frame grounding methods used in a typical telephone central office building and shows how the isolated ground plane fits into the total grounding plan for the building.

1. Install an Office Principal Ground Point Bus (see Office Ground Electrode in Glossary).
2. Install a vertical equalizer in the building to establish a low impedance path to earth reference. On each floor, connect a central office ground bus (CO GRD) to the vertical riser to form an effective earth reference. The distance between the vertical equalizer and the CO GRD shall be 20 conductor feet or less.
3. Install the SPCSS and its associated processor as an isolated ground plane insulated from building steel. Then, make a planned earth reference to these frames by connecting grounding conductors from each set of frames to the serial, radial, or mesh bonding network that connects to the Main Ground Bus (MGB) within the ground window. Connect the MGB (also known as the Single-Point Connection Bus or SPCB) to the COGB on the same floor, completing the required connections.

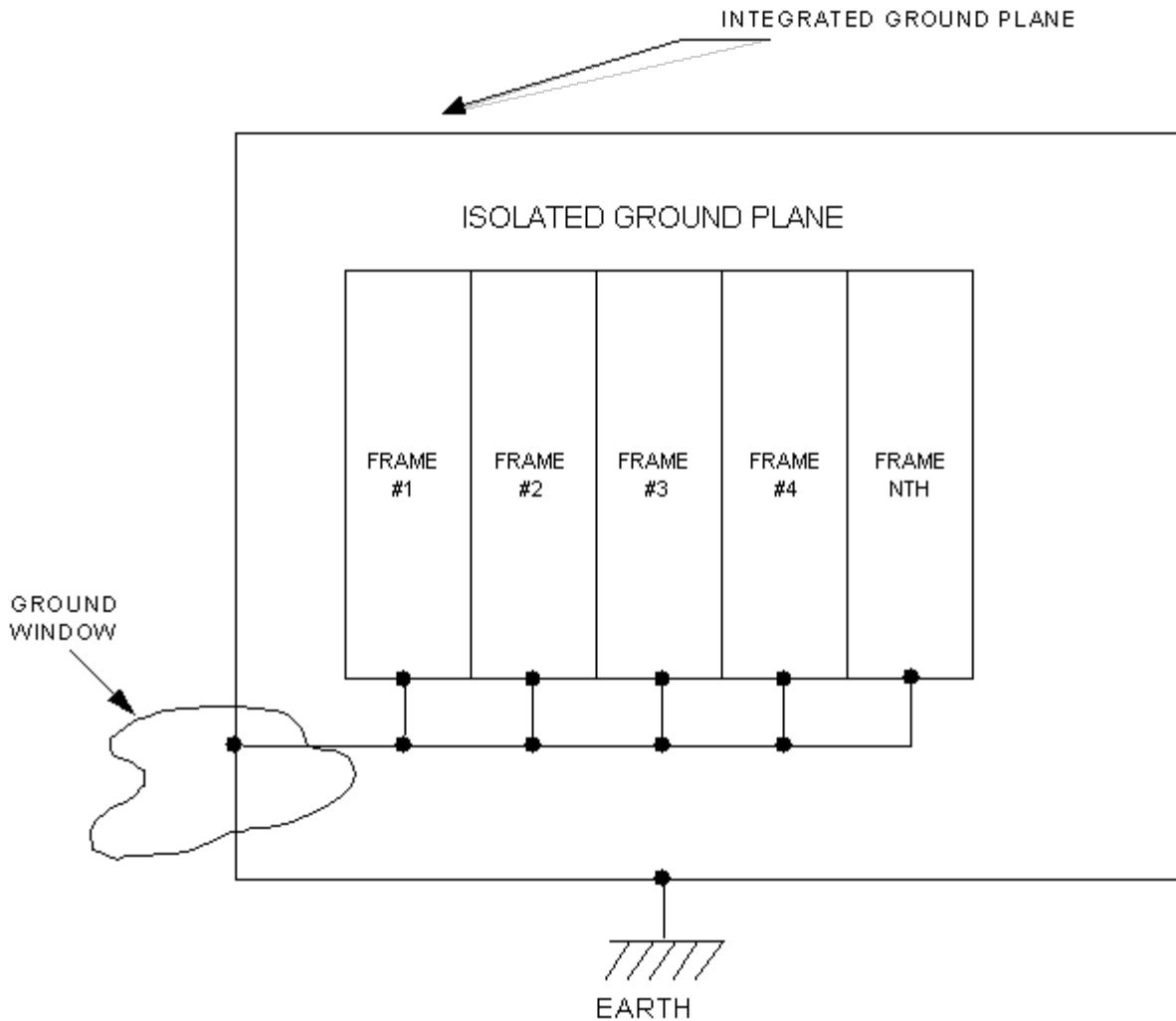

Figure 8-1: Simplified Isolated Ground Plane

When using Serial or Radial grounding (see Figure 8-2) do not add grounding conductors that would cause a direct connection between frame lineups (loop between frames). Caution shall be taken to ensure that electrical connections which cause loops are not inadvertently formed by grounded cable shields (in general, all shielded wires within the CO should only be bonded at the termination end [for cables running between the isolated and integrated planes, the termination end is in the isolated plane], regardless of which plane they are in, unless they run parallel to AC conduit or wiring in the integrated plane), metallic cable trays, metallic conduits, or other means, when serial or radial grounding is used.

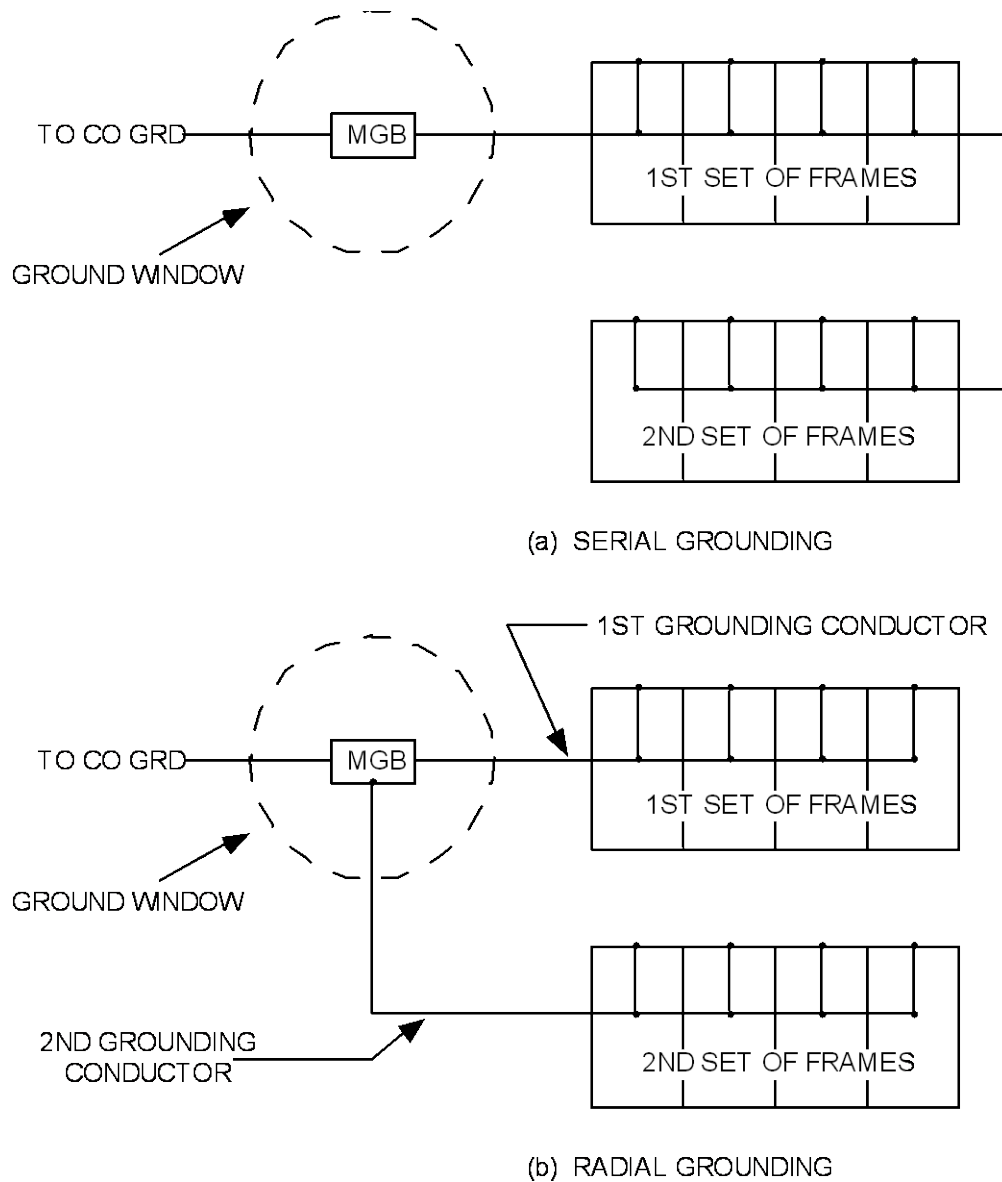

Figure 8-2: Simplified Examples of Serial and Radial Frame Grounding

Reliable frame to frame grounding connections shall be made. Route a minimum . 6 AWG bare (or insulated) stranded copper wire along each frame lineup. Using compression connectors, connect this “stringer” (with a similar wire) to each frame. If frames are painted, remove the paint at the point of conductor contact, clean all contact surfaces, and treat with a non-oxidizing agent. All connections to frames shall be made with 2-hole copper crimp connectors (for existing, working switches that use single-hole connectors, it is not required to upgrade them to 2-hole due to the hazards that drilling could pose to the operation of the switch).

4. Establish a ground window (see Figure 8-6 or 9-3) to serve the isolated ground plane. A copper bus (or buses) called the main ground bus (MGB) shall be located within the ground window to provide a place where various required connections can be made. All external grounding wires that enter and serve the isolated ground planes shall be routed through the ground window and bonded to the MGB before connecting them to the isolated ground plane.
 - The ground window can be located over the power plant or at a remote location in the immediate area of the isolated ground plane. Vertically, it shall be no more than one floor from the isolated ground plane. Horizontally, the ground window shall be no further than 100 feet (straight line distance) from the floor central office ground (CO GRD) or 100 feet (straight line distance) from the furthest member in the isolated ground plane. In no case, however, shall the furthest unit of equipment in the isolated ground plane be more than 200 conductor feet from the floor CO GRD bus (this requires special care in large offices to ensure good placement of the ground window).
 - The ground window shall be configured as a bar or a set of bars with a designated area for isolated and integrated ground connections. The isolated and integrated areas shall be separated by the 750 kcmil ground connection (see figure 8-6) from the COGB.

Note: Only one ground window shall be associated with the principal power source serving the isolated ground plane. More than one set of isolated ground plane frames may be served from a single ground window.
5. Make a ground connection from the MGB within the ground window to each group of frames. (In some cases a frame grounding bar may be used and located near the isolated ground plane to collect frame ground conductors from the various lineups. Some switches also require logic reference grounds tied to the MGB since it is a “clean” source of ground. These too may be gathered on “collection bars”.)

All ground connections from the SPCSS and processor frames going to the integrated ground plane shall be routed through the ground window (the imaginary 3 foot radius sphere) and bonded (referenced) to the MGB. All metallic objects such as conduits, cable racks, armored cable sheaths, and grounding wires associated with these frames become a part of the isolated ground plane and shall be isolated from the building integrated ground plane. All integrated grounds serving the isolated ground plane (AC conduit) shall be routed via the ground window and bonded to the MGB. These units must be insulated from the building integrated ground plane once they have been routed via the ground window (and bonded to the MGB) toward the isolated ground plane.

The grounding cables in Fig. 8-3 provide fault current paths to permit operation of overcurrent protection devices (fuses and breakers) when ground faults occur between DC "hot" leads and the frames. They don't normally carry load current.

8.5 Power Supply Grounding Methods

Generally, all power sources serving an isolated ground plane shall be single point solidly grounded. Exceptions to this rule are as follows:

- When the principal power source has a return bus that is not insulated from the plant's frame and this bus is used as the ground window, three advantages can be realized provided that an insulated auxiliary return bus is added as shown in Figure 8-10:
 - A plant that has a return bus connected to its frame can be used if it is designated as the ground window.
 - The return conductors that provide power to integrated ground plane loads from a shared power plant can be run directly to the return bus because the return bus has become the ground window.
 - The voltage stress that can build up between the return bus and the plant's frame is minimized when lightning or other fault currents flow in the building.
- Return conductors serving integrated ground plane loads (e.g., radio, electro-mechanical, and non-switched circuit equipment) from the same power plant that serves the isolated ground plane loads are permitted to multiground the power source at the loads housed in the integrated ground plane if those return conductors are routed through the ground window and bonded to the MGB.

8.6 Multigrounded Power Source

Generally, multigrounded power sources (i.e., sources with one load current carrying member grounded at more than one point in length) shall not be used to power isolated ground plane loads (see exceptions listed in paragraph 8.5).

8.7 DC Power Supplies

All DC power supplies serving an isolated ground plane shall be single point grounded.

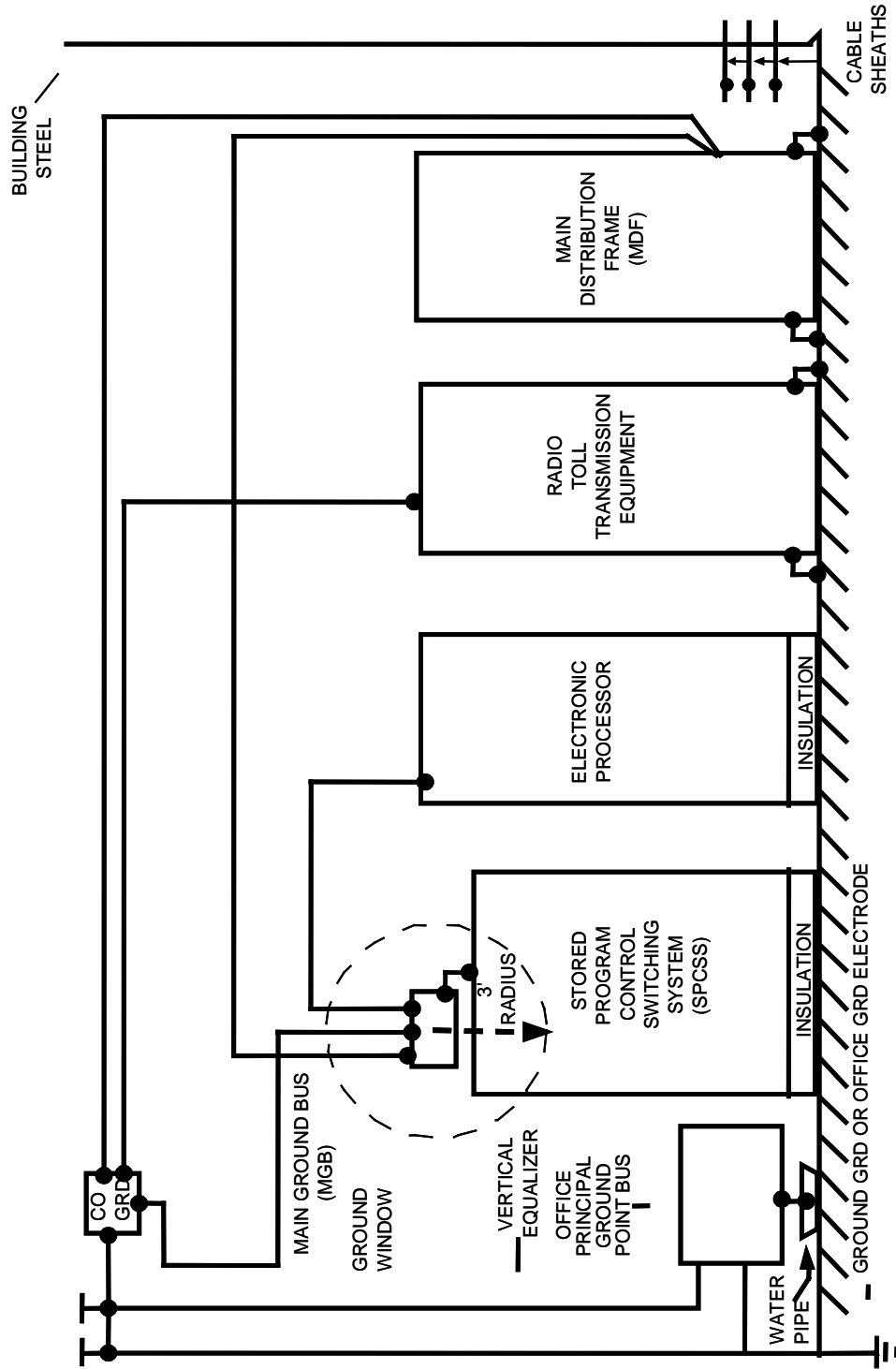

Figure 8-3: Typical Overall Frame Grounding Methods

Grounding Locations:

- The return side (usually the positive bus) of the principal power source shall be grounded with a separate 750 kcmil grounding conductor to the ground window associated with the isolated ground plane (for DC plants with a maximum rating of 600 Amps or less, this reference conductor is allowed to be as small as 1/0 AWG). The principal power source is classified as an external power source. If the positive bus is designated as the ground window it shall be grounded with a 750 kcmil to the CO ground bar (once again, this reference conductor is allowed to be as small as 1/0 AWG for DC plants with a maximum rating of 600 A or less). (If the DC plant serves only integrated ground plane equipment, its return bus still needs a reference to the nearest COGB. The sizing rules for this conductor are based on typical power plant and site size for the different types of sites. Section 5.4.1 specifies requirements for CO plants serving only integrated ground planes. Sections 7.21, 10.1, 10.3, and 10.5 specify the power plant return bus ground reference conductor size requirements for Radio Sites, CEVs, DLC cabinets, and Customer Premises installations, respectively.)
- Other external DC power sources (such as 130 volts DC) serving the isolated ground plane shall be grounded only at the ground window in the same manner as the principal power source. (Other grounding requirements for DC systems over nominal 50 Volts are covered in NEC Article 250.160.)
- Internal DC power supplies (usually DC to DC converters and rectifiers) shall be grounded at the nearest internal reference ground bus.

Return Conductors — Return conductors are the grounded conductors in DC power supplies. They shall not be used as grounding conductors.

Power Distribution Cabinets (PDCs) used to distribute DC power to the isolated ground plane loads shall be part of the isolated ground plane.

8.8 AC Power Supplies

All separately derived AC power supplies shall be grounded to agree with the NEC.

Safety Requirements — All component parts used in the AC power distribution system serving the isolated ground plane system shall be listed by a National Recognized Testing Laboratory (NRTL) such as Underwriters Laboratory (UL), and wired in accordance with the current National Electrical Code (NEC).

Raceways — All AC branch circuits serving the isolated ground plane shall be housed in metallic raceways from source to load. Each raceway shall be joined to form a continuously electrically conductive grounding path. This rule applies to circuits that have metallic contact with isolated ground plane frames, not those that pass within 6 feet of the isolated plane (foreign object grounds).

AC Equipment Grounding (ACEG) Conductor – An ACEG conductor shall be provided in all raceways housing AC circuits from source to load. This conductor shall be insulated and identified with a green color.

ACEG Requirements:

- All grounding conductors and metallic raceways associated with external AC power that feed loads within the isolated ground plane shall be routed through the ground window and bonded to the MGB.
- All grounding conductors shall be electrically connected to each junction box that they pass through, and to those on which they terminate.
- Mechanical connectors are not allowed for ACEG conductors inside the isolated equipment.

Note: A junction box refers to a pull-box outlet/receptacle box, or any similar metallic enclosure.

Single Point Grounding of AC Power Supplies – All separately derived AC power systems shall be grounded at their immediate outputs and only at that one point. Beyond the immediate output, the grounded conductor (usually called the neutral) shall not be grounded at any other point along its entire length.

General Purpose Outlets – Every outlet (receptacle) mounted on the isolated ground plane and intended for general use shall be the standard type that connects its grounding terminal to its frame. Isolation outlets (marked isolated or orange colored, or with an orange triangle) are prohibited going forward except when extending from an existing isolation outlet.

8.9 General Isolated Grounding Conductor Requirements

Grounding conductors shall be used only to ground power supplies and frames. They shall not be connected in parallel with battery return conductors unless the SPCS is designed that way.

The size of the grounding conductors shall be as specified by the SPCSS supplier. In no case shall the DC grounding conductors be smaller than a No. 6 AWG wire or equivalent. DC grounding conductors used to ground frame members of the isolated ground plane can be bare or insulated. All other conductors shall be insulated.

Generally, DC grounding conductors may be run near each other regardless of the equipment they are grounding. However, in rare cases, a switch manufacturer may specify that certain grounding conductors in the isolated ground plane be segregated. In these cases, the switch manufacturer and the installation vendor must clearly mark those runs that must be segregated for noise or other reasons.

Armored cable containing a bare bonding strip to decrease sheath resistance shall not be used as an equipment ground conductor.

8.10 Induction Effects

Induction effects on the isolated ground plane should be minimized by avoiding the formation of inductive loops and by routing lightning and fault current carrying members in paths that are as far away as practical from the isolated ground plane.

8.10.1 Loops in the Isolated Ground Plane

Paragraphs 8.4 and 8.11.5 shall be followed to avoid forming large area inductive loops (see Figure 8-4) among the grounding conductors of the isolated plane. Don't use the so-called "-48 V return horizontal equalizing conductors" where the -48 V return bus in each DC distribution cabinet (PDC) is sequentially connected from PDC-to-PDC to form a completed inductive loop, with the last PDC bus connected to the first.

Of course, in an integrated ground plane, loops are unintentionally formed. So, if a switch manufacturer does not require an isolated ground plane, loops are allowable. Internal loops in the isolated plane are also allowable if the switch manufacturer has specified mesh bonding of their frames. Follow the switch manufacturer's guidelines for internal grounding.

8.10.2 Lightning and Fault Current Carrying Members

The following types of conductors shall be routed a minimum of three feet from the boundaries of the isolated ground plane:

- The grounding conductors from the ground window and the CO GRD to the main distributing frame (see Figure 8-3).
- Wave guides and coaxial cables from tower mounted antennas.
- Metallic raceways from other systems.
- Cables coming from other external antennas (such as GPS, PCS, etc.).

8.10.3 Nearby Integrated Ground Plane Frames

All integrated ground plane conductive members located within six feet of the isolated plane shall be bonded to the MGB (equipment frames may also be bonded to the CO GRD system, but that is not required; nor is it required to individually connect each equipment frame to the FOG system — a connection to a lineup stringer is sufficient) to reduce shock hazards to personnel and minimize surge potential differences between members of the two planes. This includes structure supporting the MGB. Steps must be taken to ensure that there is electrical continuity between members of nearby metal. If such continuity cannot be verified by a less than one ohm reading across junctions then the metal objects must be bonded.

The bond to the MGB (integrated bar) can be accomplished by running a minimum #2 AWG to the area and bonding all components with # 6 AWG, or by installing a collector bar (FOG, ICB) where bonding of all components can be accomplished. Such frames include:

- Metallic stands and desks
- Circuit Pack (PIC) cabinets (these cabinets need to be grounded to the integrated plane anyway if they are outside of the 6 foot separation).
- Equipment frames
- Miscellaneous Iron (auxiliary framing, metal conduits, air-conditioning duct, cable racks, etc.); which can achieve continuity between separate parts by incidental metal-to-metal contact (e.g., sheet metal screws are OK as long as the resistance between connections is less than 0.1 ohms – otherwise scrape the paint/ galvanization, etc.)
- Lighting fixtures that are not part of the isolated ground plane
- Air ducts
- Metallic raceways from other systems

AC raceway from the MGB to the isolated switch is technically part of the isolated plane, and is FOG grounded per the list above. It often travels great distances from the MGB to the switch, often changing floors. Along this path, it may pass within inches of a lot of different integrated grounding plane members. However, because of the number of integrated ground plane members it (and other FOG raceway) passes, and the fact that they are typically out of human reach (up in the overhead racking area), it is not necessary to FOG ground all of the integrated members that AC raceway attached to a FOG bar passes while in the integrated area.

8.11 Isolating Ground Plane Frames (Specific Requirements)

8.11.1 Specific Requirements

The set of frames designated as the isolated ground plane shall be one conductive unit. All of its metallic surfaces and grounding conductors shall be bonded together with planned electrical connections. Incidental grounds are not acceptable. Lighting frames, receptacle housings, end guards, raceways, and other peripheral parts of the isolated ground plane shall be part of the one conductive unit.

8.11.2 Insulation Resistance

All frames that are part of the isolated plane shall be installed in a way that insulates them from the integrated plane (building steel and other metallic parts attached to it). Before any ground window or power connections are made to the isolated ground plane, and after all hold down and fastening hardware is installed, the insulation resistance between the isolated and integrated ground planes shall be verified to be 100,000 ohms or more (see Section 8.21.4 for isolation test methods), and preferably greater than 2 megohms. The isolated ground plane shall be isolated from the building's integrated ground plane by using insulators between points where metalwork and concrete common to the integrated ground plane must be fastened to the metalwork that is common to the isolated ground plane. Typical fastening points include the following:

- **Anchor Bolts** – Isolated ground plane anchor bolts might touch grounded structural metal in the floor. Therefore, these bolts shall be insulated from the isolated ground plane.
- **Bottom of Frames** – If there is any possibility that the bottom of the frames in the isolated ground plane come in contact with structural metal, concrete floors, or floor tiles, insulating material shall be placed between the frames and floor.
- **Superstructure Supports** – Superstructure supports to the isolated ground plane, where used, shall be insulated.
- **Lighting Fixtures, etc.** – Lighting fixtures, raceways, and cable racks that are part of the isolated plane shall be insulated from the integrated ground plane.

8.11.3 Frame to Frame Connections

Reliable frame to frame grounding connections can be made in several ways. Two typical ways are described here:

- Route a minimum No. 6 AWG bare or insulated stranded copper wire along each frame lineup. Using crimp type connectors, connect the ground wire to a grounding lug supplied on each frame.
- Some SPCSS utilize a bare copper bus connected to each frame, interconnect each bus section with a crimped, braided strap. The cross sectional area of the bus and the braid shall be equal to or greater than No. 6 AWG stranded copper conductor (about 0.027 square inches).

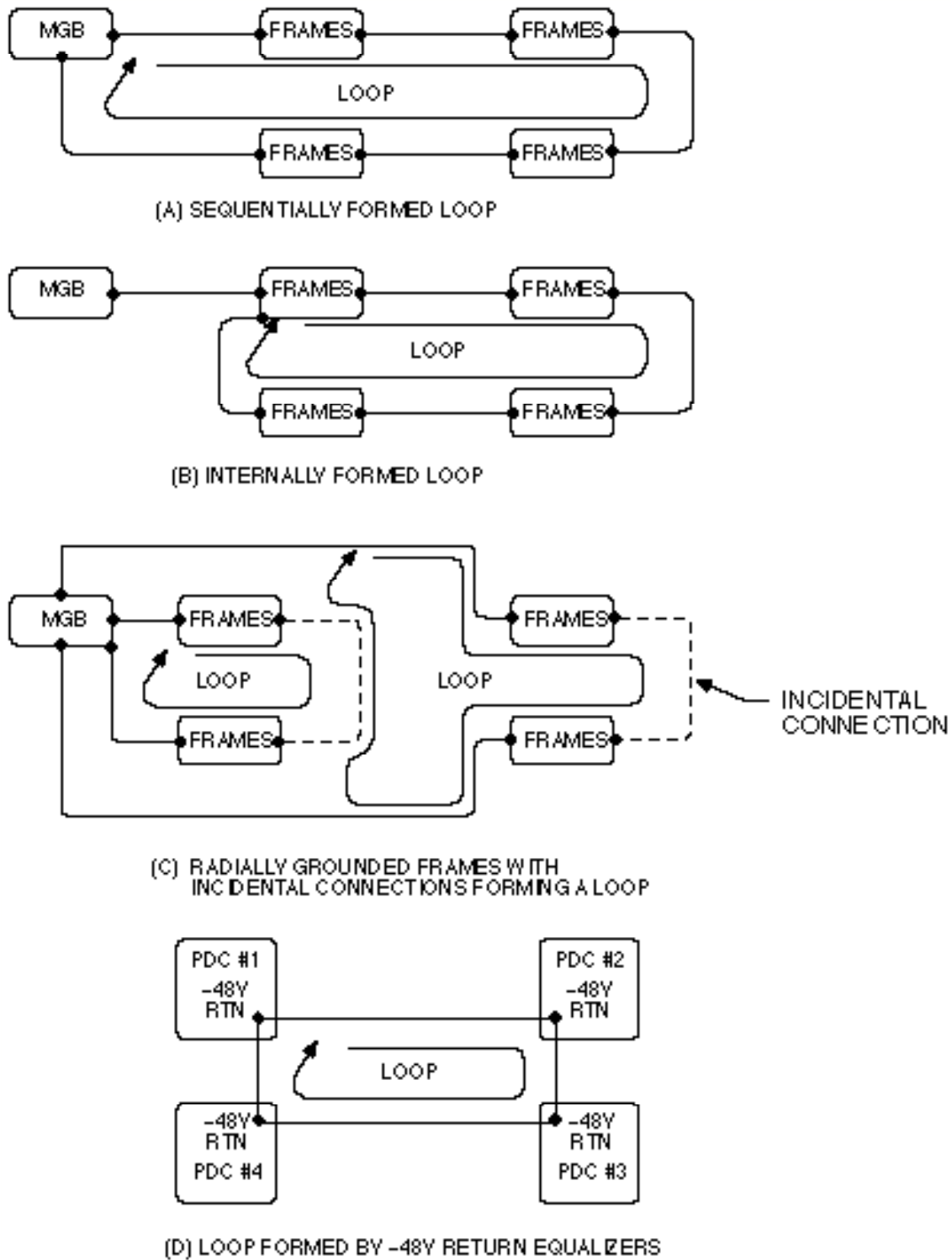

Figure 8-4: Loops (Isolated Ground Plane)

8.11.4 Grounding Among Groups of Frames

It is possible to ground the groups of frames in an isolated ground plane by either of two basic methods:

- A method that deliberately avoids the formation of frame ground loops within the isolated ground plane.
- A method that deliberately permits the interconnection of groups of frames in such a way that numerous frame ground loops are formed.

Either method is acceptable in accordance with the vendor's grounding design strategy. The vendor shall state the method that is to be employed.

The size of the grounding wire used between groups of frames and the MGB shall be a minimum of No. 1/0 AWG.

8.11.5 Serial and Radial Connections Within the Isolated Plane

Both serial and radial grounding connections are permitted from the ground window to sets of frames within an isolated ground plane. When the radial grounding technique is used, the following criteria shall be met:

- No additional grounding wire connections that would cause an inductive loop to be formed should be made between the radially grounded sets (see Figure 8-4).
- If digital carrier transmitter or receiver circuits are within the respective radially grounded sets of frames, then these circuits should have their outputs isolated to avoid closing an inductive loop.
- Electrostatic shields that might be used to enclose interconnecting wires between radially grounded sets should be grounded to the frame at only one end
- Magnetic shields that might be used to enclose interconnecting wires between radially grounded sets should be run close to the frame grounding conductor. The shield itself should pass through and be connected to MGB.

8.11.6 Limits on the Number of Floors an Isolated Ground Plane can Occupy

Limits on the number of floors an isolated ground plane can occupy is as follows:

- A given isolated ground plane shall occupy no more than three adjacent floors.
- Only one ground window and one principal power plant shall serve the isolated ground plane. The ground window shall be located in the middle floor of the three consecutive floor configurations.

8.11.7 Peripheral Equipment Frame Grounding

Peripheral metallic equipment frames (e.g., teletype printers, metallic desks, video and hard copy terminals, etc.) shall be connected with grounding conductor(s) to the isolated ground plane (see Section 8.10.3 for a more complete list), and shall be treated as if they were an integral part of the isolated ground plane. AC or DC power for these loads shall come from sources within the isolated ground plane or from sources routed through the ground window, as per paragraph 8.16. The grounding conductors associated with these power sources shall be used to extend ground reference to the peripheral equipment's frame without making contact with the integrated ground plane. Peripheral equipment grounded in this manner shall be within one floor of the ground window serving the isolated ground plane. Peripheral equipment located more than one floor away from the ground window serving the isolated ground plane shall not have any metallic grounding connections to the isolated ground plane members. If this type of equipment must be treated as an isolated ground plane, it is desirable to power it from the same principal power source through input/output isolated DC-to-DC converters. A second ground window on the "secondary" side of the DC-to-DC converters then can be established to ground the peripheral equipment frames. This "new" ground window shall be located within one floor of the peripheral equipment. But the ground windows shall not be bonded together.

Note: It is desirable that isolation techniques, such as optical fiber, current loop, or back-to-back modems be used between the peripheral equipment and the isolated ground plane frames, thus enabling the peripheral equipment to be grounded as part of the integrated ground plane and to be powered from commercial AC.

8.12 External Principal Power Plant Grounding Requirements

The principal power plant frame serving an isolated ground plane is not part of the isolated ground plane it serves.

8.12.1 The Return Bus

The return bus (usually the positive polarity side of the system) in the power plant shall be insulated from the plant's frame.

Note: The return bus referred to in this publication is sometimes called the -48 volt return bus, the battery return bus, or the ground return bus. For an exception to this rule, refer to paragraph 8.19.5, Requirements for Plant with a Noninsulated Return Bus.

8.12.2 Grounding the Return Bus

The return bus in the power plant shall be grounded to the MGB (isolated) within the ground window with a 750 kcmil conductor.

8.12.3 Grounding the Plant's Frame(s)

For personnel safety, the plant's steel framework (distribution and rectifier bays) shall be grounded at the nearest ground reference (often the CO GRD located on the same floor) with a grounding conductor sized per section 5.4.1. An additional frame-grounding conductor shall be installed between the plant's framework (all distribution and rectifier bays) and the main ground bus within the ground window. This conductor shall follow the path of the plant's ground reference conductor for remote ground windows (see Figures 8-7 and 8-8). A single conductor can be used for frame grounding all frames in the power plant (and a separate single conductor may be used to reference all the DC plant PBD frames to the integrated side of the MGB in the ground window per Figures 8-6 and 8-9), but they should be separate from the reference conductor for the return bus (per NEC 250.168).

8.12.4 Location of the Power Plant

The location of the power plant with respect to the isolated ground plane is not restricted provided that the -48 volt return bus in the plant is not used as a ground window (see paragraph 8.19.2).

8.12.5 Power Feeders

The power feeds from the principal power source shall be run in pairs to each PDC (or equivalent, since different switch manufacturers give this secondary distribution point different names). The pairs shall be routed in close proximity to the plant's grounding electrode conductor and frame grounding conductor. At the PDC, the "hot" conductor and the return conductor shall be insulated from the frames. The return conductor in the pair shall NOT be connected to the main ground bus at the ground window, unless the battery return bus is used as the ground window.

Power feeders to integrated ground plane loads, run from a power plant that serves both isolated and integrated ground planes, must have the return conductors pass through a remote ground window (in the cases where a remote ground window is used and the downstream equipment or BDFB return is also bonded to the nearest COGB) and be bonded to the MGB (see Figure 8-6 and Table 8-1). For this situation, special exceptions to the pairing rule mentioned in the previous paragraph are allowed (see CenturyLink Technical Publication 77385, Section 8.6 for further detail). In addition, exceptions to this rule are allowed for separately derived (isolated) power sources. For example, the return conductor of DC feeds to isolated output DC-DC converter plants, inverters, and ring plants do not have to be bonded to a remote ground window.

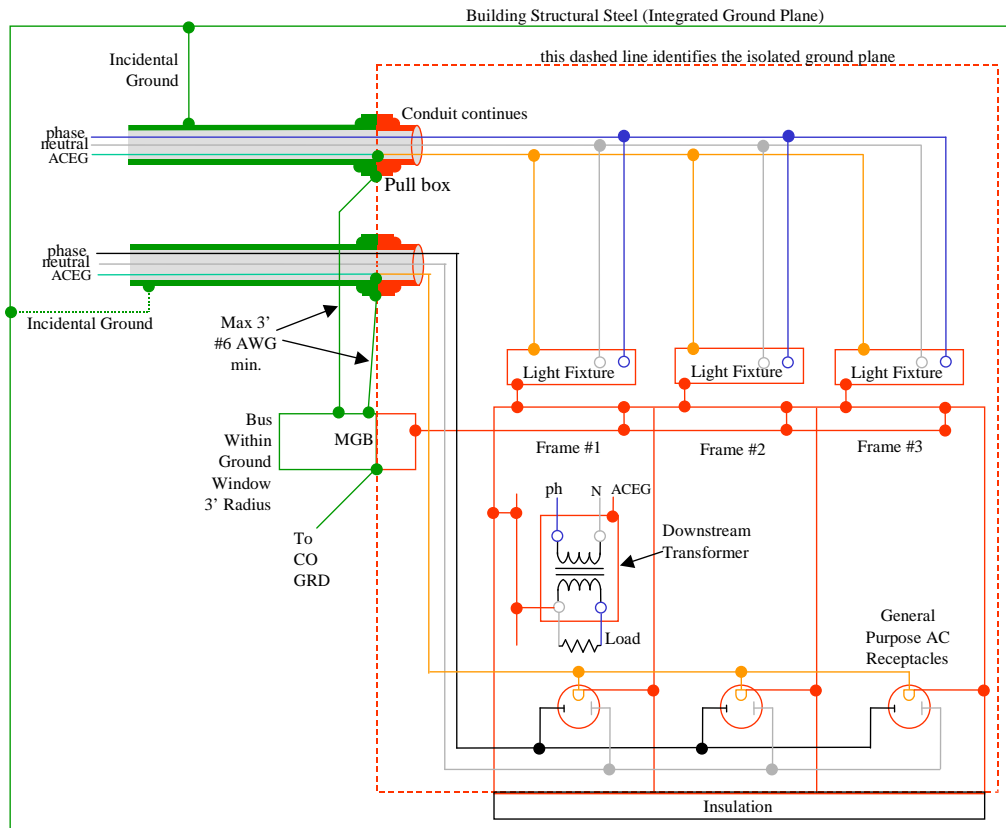

NOTES

- (1) Light fixtures are shown as part of the isolated ground plane for illustration purposes only. It is recommended that light fixtures be part of the integrated ground plane.
- (2) Often, all AC conduits entering the isolated plane run through a common junction box near the MGB, necessitating only one connection from this box to the MGB.

Figure 8-5: Typical Grounding and AC Power Feed to an Isolated Ground Plane

8.13 Integrated Ground Plane Loads

Integrated ground plane loads fed from the same principal DC power source that supplies the isolated ground plane loads shall be examined to determine if powering such loads multigrounds the battery return conductor. If the battery return conductor is multigrounded at the distribution point or at the loads themselves, it shall then be routed via the ground window and bonded to the MGB before it is run to the return bus within the power plant. The length of the bonding conductor shall be no longer than three feet (the size of the bonding conductor is specified in Table 8-1). The battery and return conductors shall be paired to the greatest extent practicable between the power plant and the equipment being powered (see the previous section 8.12.5 for additional information on pairing and bonding of integrated ground plane loads fed from a plant that also serves isolated ground plane loads).

Note: In some older installations, the return conductors actually terminated on and/or passed through the MGB instead of being bonded to it. In these cases it must be ensured that the cable between the MGB and the -48 V plant return bus is the 750 kcmil conductor specified in Table 8-1. If this cable is carrying excessive current (greater than 300 Amperes) or is hotter than 115 degrees F, more cables may need to be added.

Note: Multigrounding occurs if the return conductors to these loads have not been insulated from the integrated ground plane frames along their entire length.

Examples:

- A local power distribution bay in the integrated ground plane whose return bus is connected to its frame and ground referenced to CO Ground (BDFBs will normally be multigrounded).
- Loads in the integrated ground plane that have a common return connected to the frame in which they are mounted.
- Wiring options in plugs and connectors that interconnect the case and the return conductor

If the power conductor serving integrated ground plane loads is not multigrounded anywhere along its length or at the load, it shall not pass through the ground window or be connected to the MGB.

Example: The input power feed to separately derived power supplies, such as 130 volt converters or 120-volt inverters whose output serves integrated ground plane loads (note that inverters installed in the isolated ground plane shall not power loads outside the isolated plane).

8.14 Loads Fed from Internal Power Sources

Power distribution sources within the isolated ground plane, typically only power isolated ground plane loads; and powering of integrated ground plane loads from these sources is usually strongly discouraged. However, when integrated ground plane loads, fed from power sources internal to the isolated ground plane, multiground the return conductors, these return conductors shall be routed through and connected to the MGB within the ground window before they are connected to the power source return bus.

8.15 Grounding Internal DC and AC Power Supplies Within the Isolated Ground Plane

Separately derived AC and DC power supplies shall be single-point grounded by making a connection from the conductor on the output that is designated to be grounded to the nearest appropriate ground reference bus. This grounding conductor shall not be used to conduct normal load current. The grounding location shall be at the immediate output of the power supply. Loads should be powered with separate pairs of conductors, and the frames containing the loads shall be grounded.

Note: The grounded conductor of the input power to a separately derived source (e.g. the AC neutral or the -48 volt return lead) shall not be connected to any frame. This violates the single-point ground of these power sources.

8.16 Grounding the External AC and DC Power Supplies Feeding Isolated Ground Plane Loads (Other Than the Principal Power Source)

8.16.1 DC Power Supplies

These power supplies shall be grounded in the same manner as the principal power source. That is, a separate grounding conductor (sized correctly as shown in Figure 8-5 and Table 8-1) shall be run from the grounded side of the supply's output to the MGB within the ground window. Load conductors shall be run in pairs and closely coupled.

8.16.2 AC Power Supplies

These power supplies, grounded at the source as described in paragraph 8.15, shall be routed through the ground window. Each grounding conductor and raceway associated with each supply shall be connected to the MGB within the ground window with a conductor that is no longer than three feet (these connections and wire sizes are shown in Figures 8-5 and 8-7).

All AC raceways running beyond the ground window toward the isolated ground plane shall be insulated from the integrated ground plane and from any incidental grounds. Where required, a separately derived dedicated AC power supply located and grounded at the ground window may be used.

8.16.3 Treatment of the AC Conductors

The AC neutral shall not be connected to the MGB. Within the isolated ground plane, AC power conductors shall be run in separate metallic raceways that do not contain DC conductors.

8.17 Specific Examples of AC and DC Grounding Principles for Isolated Ground Planes

Figures 8-5 and 8-7 illustrate the AC and DC grounding requirements of this document. The dashed line in each of the figures identifies the boundaries of the isolated ground plane. The figures show the grounding of frames and power sources and indicate grounding conductor sizes. They also show AC and DC power distribution to the extent that it relates to meeting the grounding requirements. Power to loads that are not part of the integrated ground plane, such as lighting fixtures, are not shown.

8.18 Establishing a Ground Window

A ground window shall be established to serve the isolated ground plane. A copper bus (or buses) called the main ground bus (MGB), shall be located within the ground window to provide a place where various required connections can be made. The MGB (also known as the Single-Point Connection Bus or SPCB) shall not be mounted on any of the isolated ground plane frames. The MGB shall be mounted on insulators so that it is insulated from the building integrated ground plane. (The only exception to this rule is if the grounded battery return bar is the ground window.) The ironwork supporting the MGB, however, must be bonded to the MGB. Only one ground window shall be associated with the principal power source serving the isolated ground plane. More than one set of isolated ground plane frames may be served from a single ground window.

Note: The MGB within the ground window shall be clearly identified by stenciling or other means. In addition, the MGB shall be identified as to isolated and integrated ground connections.

8.18.1 Dimensions

The ground window's dimensions shall be those of an imaginary sphere with a maximum radius of 3 feet (a 6 foot diameter sphere whose center is an imaginary point in space). The MGB (on the integrated side) shall be a maximum of six conductor feet in length from the COGB connection integrated-isolated split point.

8.18.2 Location

The ground window can be located in the principal power plant as the battery return bar. The ground window can also be located in a remote area as close as possible to the isolated ground plane it serves. Vertically, it shall be no more than one floor from the isolated ground plane. Horizontally, the ground window shall be no further than 100 feet (straight line distance) from the floor central office ground (CO GRD) or 100 feet (straight line distance) from the furthest member in the isolated plane. In no case however, shall the furthest unit of equipment in the isolated ground plane be more than 200 conductor feet from the floor CO GRD bus.

8.18.3 Connections

A number of possible connections can be made on the MGB within the ground window, depending upon the needs of the various installations. Figure 8-6 and Table 8-1 show typical detail connections. The MGB shall be configured to separate isolated and integrated ground connections. The MGB can be thought of as the transition conductor between the integrated and isolated ground planes. The sequence of connections shown in Table 8-1 should be followed. Table 8-1 identifies sizes and classifies the conductors shown in Figure 8-6. No connections shall be made between the isolated ground plane and the integrated ground plane other than through the MGB. All conducting materials that are part of the isolated ground plane such as cable racks, cable troughs, conduits, armored cable, enclosed conductors, and the SPCSS frames shall be insulated and kept separated from the integrated ground plane.

As a special note for lead 9 in Figure 8-6 and Table 8-1 (which represents multigrounded integrated ground plane load -48 V return conductors), Table 8-1 states that the maximum bonding conductor size for these conductors (to bond them to the MGB as they pass through the ground window) is a 1/0. Due to length and load, sometimes the return conductors for a single load may be multiple cables. In these cases (where there are multiple return conductors for a single load) the return conductors for that load can be H-tapped together and then bonded to the MGB with a single 1/0 (bonding jumpers do not need to be run to each return conductor of a particular feeder return).

8.19 Ground Window Configurations

Three ground window plant configurations may be used with isolated ground plane:

- A separate ground window (remote).
- A ground window developed from a plant with an insulated battery return bus.
- A ground window developed from a plant that does NOT have an insulated battery return bus.

8.19.1 Separate Ground Window

Requirements for this type of plant are covered in paragraph 8.18 and Figures 8-6 and 8-8.

8.19.2 Using the Return Bus as the Ground Window

In some locations, it's practical to use the principal power plant's return bus as the ground window serving an isolated ground plane. Figures 8-9 and 8-10, respectively, show typical arrangements for insulated and noninsulated return bus plants. Three advantages can be realized:

- A plant that has a return bus connected to its frame can be used.
- The return conductors that provide power to integrated ground plane loads from a shared power plant can be run directly to the return bus because the return bus has become the ground window.
- The voltage stress that can build up between the return bus and the plant's frame is minimized when lightning or other fault currents flow in the building.

Note: Connections of battery return conductors for isolated ground plane loads are not considered to be located within the ground window.

As noted in Section 8.19.3 and in Figure 9-1, when the power plant return bus is used as the ground window, the plant must be located within one floor of the isolated ground plane. In some offices, this may preempt the use of the power plant return bus as the ground window.

8.19.3 Requirements for Both Kinds of Plants

The MGB must be located within 1 floor of all isolated frames. The location of the power plant in relation to the isolated frames or the MGB is unrestricted if a remote ground window is used. However, if the MGB and the plant return bus are common, the power plant must be within 1 floor of all isolated frames. Integrated equipment that might be powered from the same plant has no location restrictions.

In plants with a common return and charging bus, the charging leads from the rectifiers are connected to the isolated section of the bus (these connections are not shown on Figures 8-9 and 8-10).

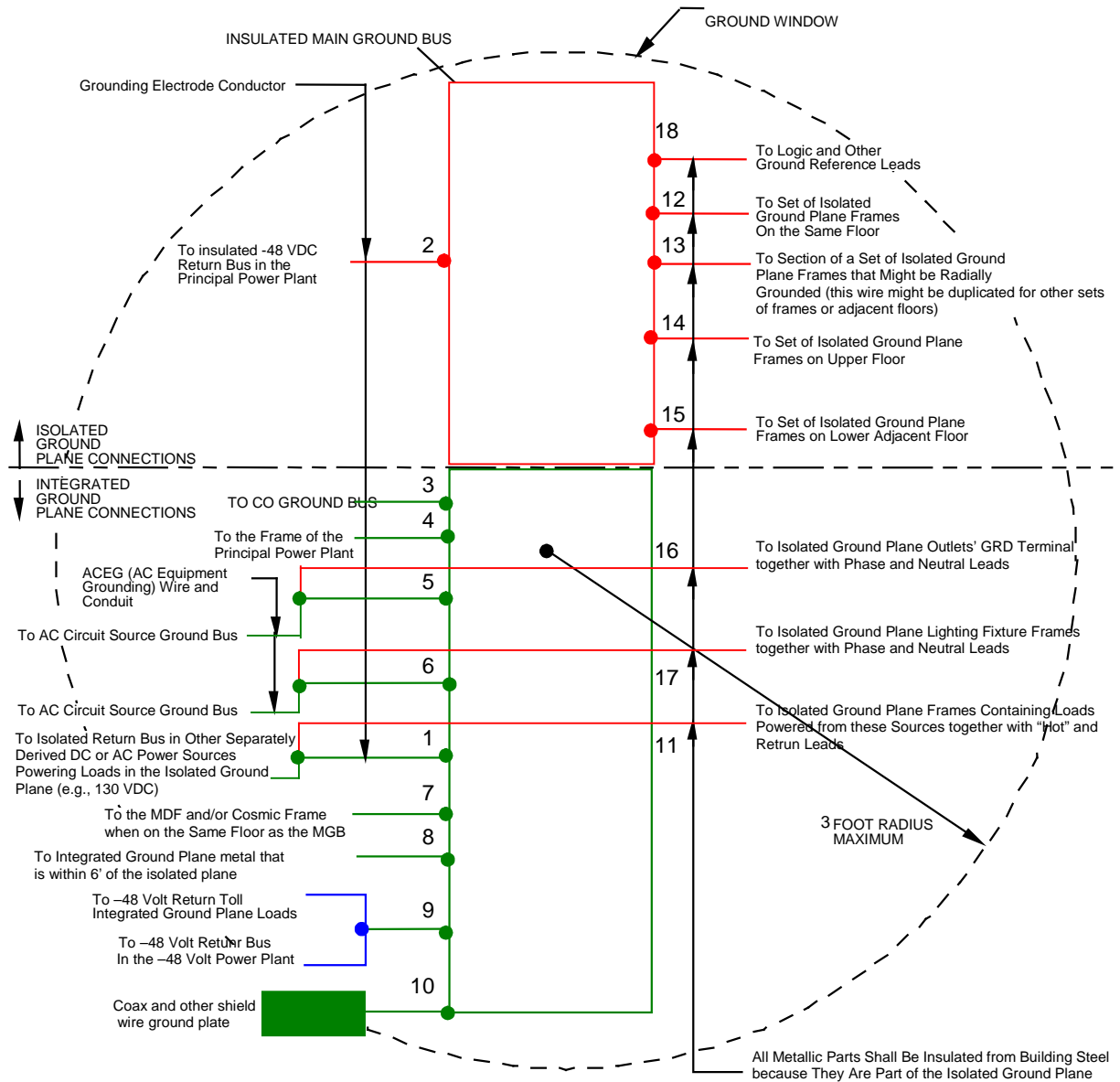

NOTES

1. Lead numbers on this figure are listed in the Conductor identification column of Table 8-1.

Figure 8-6: Typical Sequence of Connections to a Separate Ground Window

Table 8-1: Tabulation of Typical Ground Window Connections

Conductor Identification (see Figure 8-6)		Can Conduct				Required in All Plants		Required in Some Plants (Yes)	Wire Size (AWG)
		Lightning Current		Fault Current		Yes	No		
		Yes	No	Yes	No	Yes	No		
1	External Power Sources Grounding Conductors	x		x			x	x	#6
2	Principal Power Supply Grounding Electrode Conductor		x	x		x			750 kcmil
3	Main Ground Bus to CO Ground (COGB) Connection	x		x		x			750 kcmil
4	Principal Power Plant Frame Ground Reference Wire for remote Ground Windows (tie all frames with a #6 AWG to the common conductor)	x		x		x			1/0: <50' 4/0: 50-100' 350: 100-150 500: 150-200' 750: >200'
5 6	External Power Sources Grounding Conductors	x		x			x	x	#12 minimum #10 for 2 AC ckts #6 for 3 or more
7	Main Distributing Frame (MDF) and/or Cosmic Frame Protector Frames' Grounding Wires (only applies when this frame is on the same floor as the MGB)	x		x			x	x	1/0
8	Grounding Wires for integrated ground plane metal within 6' of isolated plane	x		x			x	x	#6 (for individual frames), or #2 for collector bar/cable
9	Toll (Integrated Ground Plane) Loads' -48 V Return Leads (probably multiple leads)	x		x			x	x	same size as the load conductor (maximum 1/0)
10	Connection bar for coax shields and other shield wires connected to the isolated plane	x		x			x	x	#6
11	Continuation of Grounding Conductor (and Conduit) from Associated External Sources		x	x				x	same size as the associated phases and neutral
12 - 15	Isolated Ground Plane Grounding Conductors		x	x		x			1/0 minimum
16 17	Continuation of Grounding Conductor (and Conduit) from Associated External Sources		x	x				x	same size as the associated phases and neutral
18	Logic and other "Quiet" Ground Reference Leads			x			x	x	per equipment vendor

8.19.4 Requirements for Plants with an Insulated Return Bus

All grounding and return conductors that can conduct lightning or fault currents should be grouped together along one section of the bus (integrated), and preferably in the sequence shown in Figure 8-9. This section (marked on the Figure with a bracket) is the ground window, and should be 6 conductor feet or less. Return conductors that serve loads in the isolated plane should be grouped along the end of the bus (isolated side), out of the direct path of lightning or short circuit currents. Isolated load return conductors and battery connections are technically not a part of the ground window, but because they connect to combination MGB/return buses, they are often contained within the 6 foot ground window sphere.

8.19.5 Requirements for Plants with a Noninsulated Return Bus

Lightning and short circuit currents can flow on the noninsulated return bus because the bus is connected to the plant's frame. If the return conductors serving the isolated plane loads were connected to this bus, dangerous voltage differences between these conductors could be generated when these currents flow.

A way to prevent this is to add an insulated auxiliary bus, and then make one connection to the return bus, as shown in Figure 8-10. This is equivalent to an insulated bus plant, because now the return conductors serving isolated loads can be connected to the new section on which no significant lightning current can flow.

Note: The single point connection between the isolated and noninsulated bus should be implemented with a bus assembly that has sufficient ampacity. If the bus assembly is impractical for some installations, paralleled conductors of equal ampacity and length assembled with abutting connectors are OK.

The sequence of conductor connections to the noninsulated and the insulated return bus is the same as described for an insulated plant.

8.20 Methodology for Establishing an Isolated Ground Plane

The procedures listed below shall be followed to meet the objectives of this publication:

- Install and assemble the isolated ground plane frames as a single conductive unit.
- Test the insulation resistance between the installed frame assemblies and the building integrated ground plane before making any external connections. Resistance shall equate to 100,000 ohms or more when 500 volts DC is applied.
- Establish a ground window within one floor of the isolated ground plane.

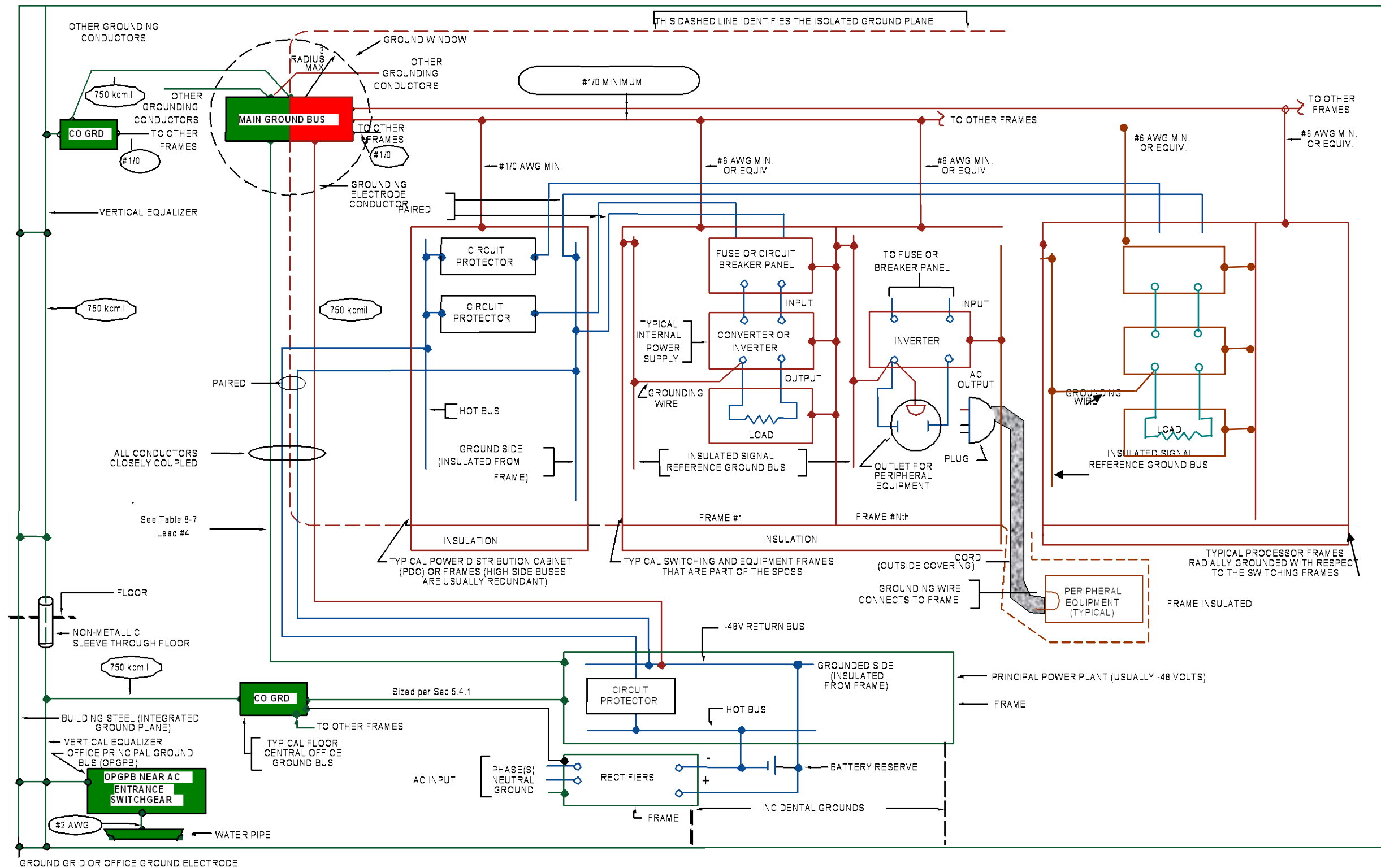
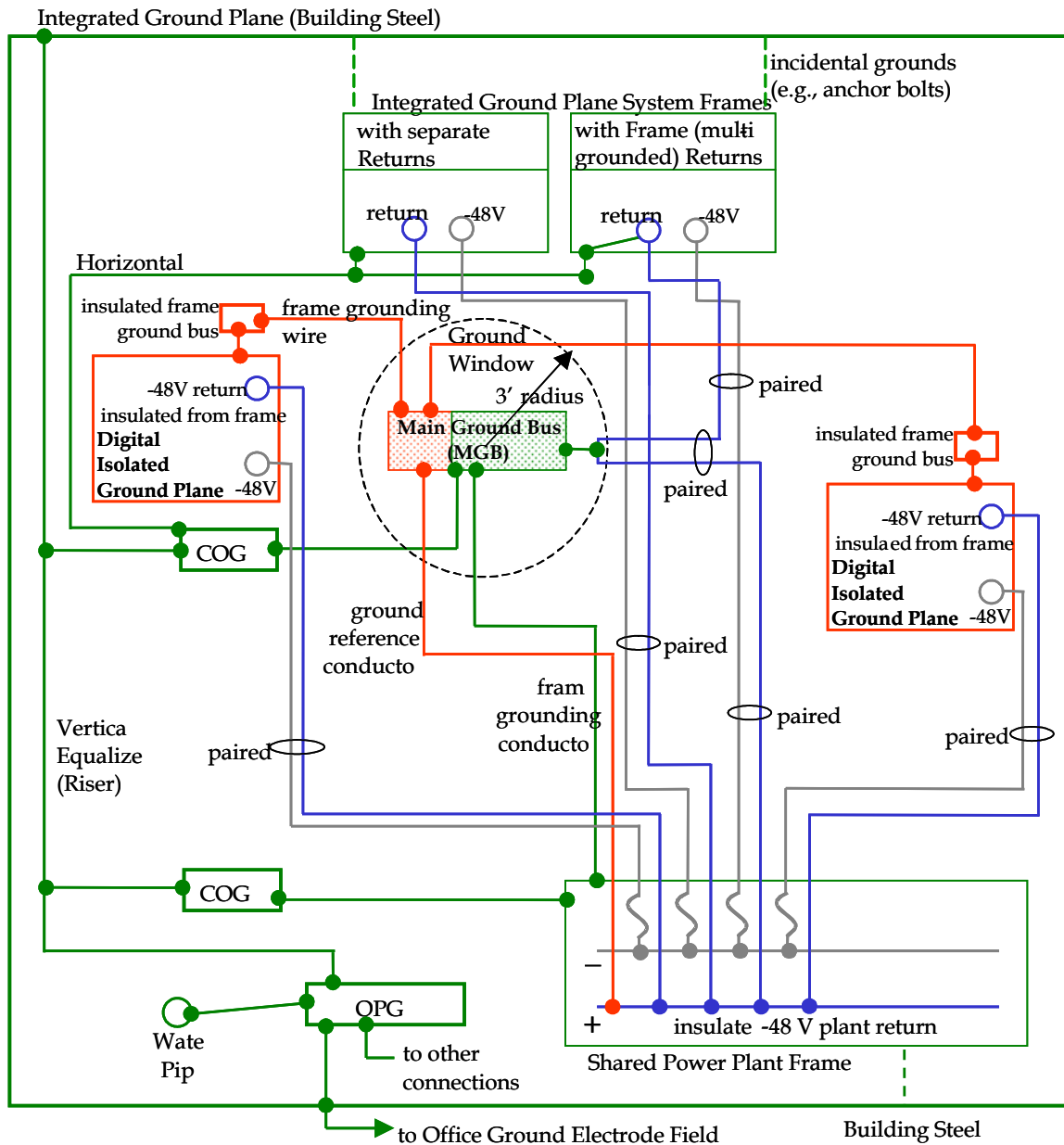

Figure 8-7: Typical Grounding and Power Feed from a DC Power Plant Powering Isolated Ground Plane Loads



NOTE:

All Isolated Ground Planes Shall Be Within One Floor of the Ground Window

Figure 8-8: Grounding for Integrated and Isolated Ground Planes Powered from a Common Power Plant

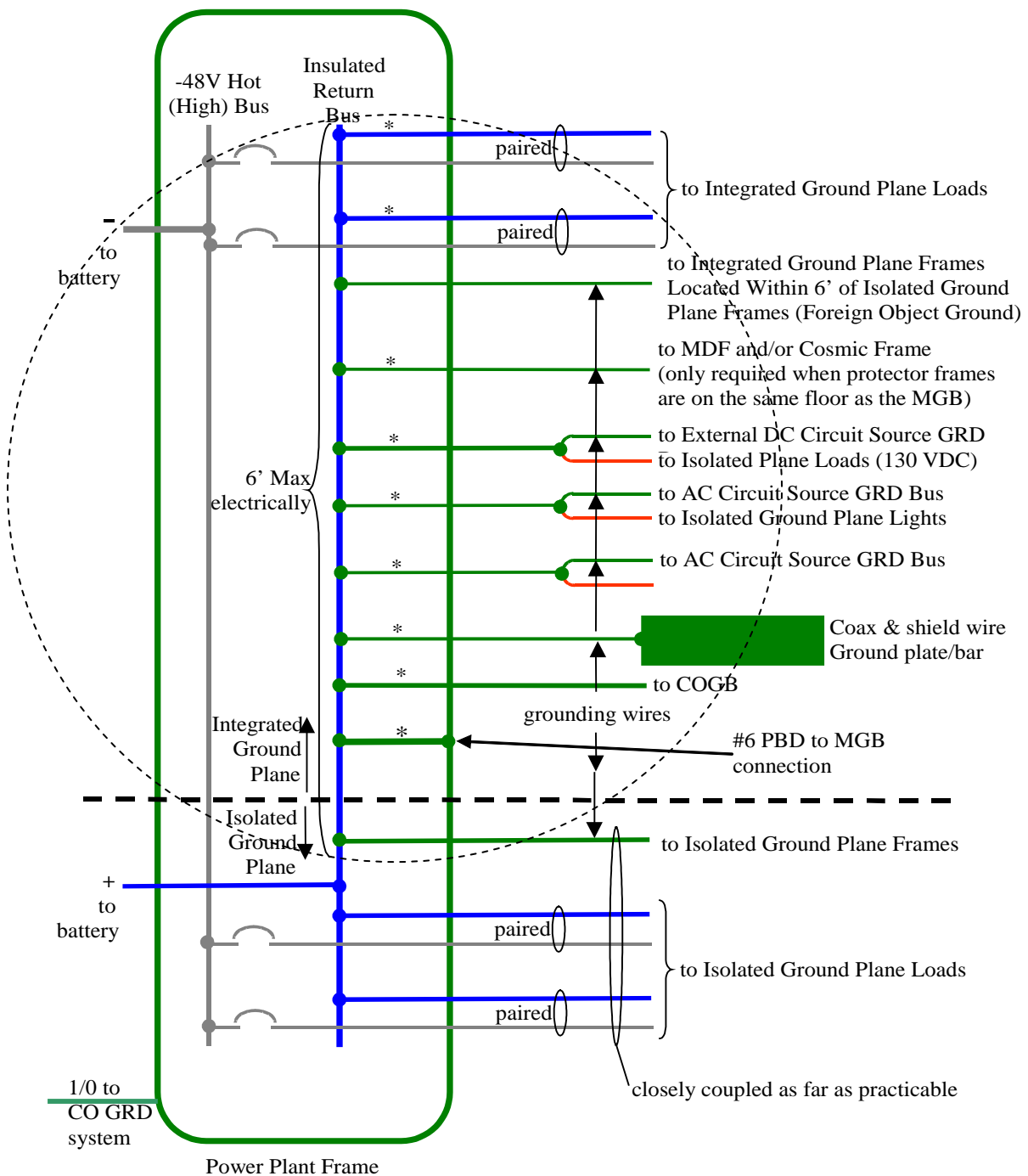

* Indicates Wires that Can Conduct Lightning or Fault Currents Into and Out of the Ground Window

Figure 8-9: Using an Insulated Return Bus as the Ground Window

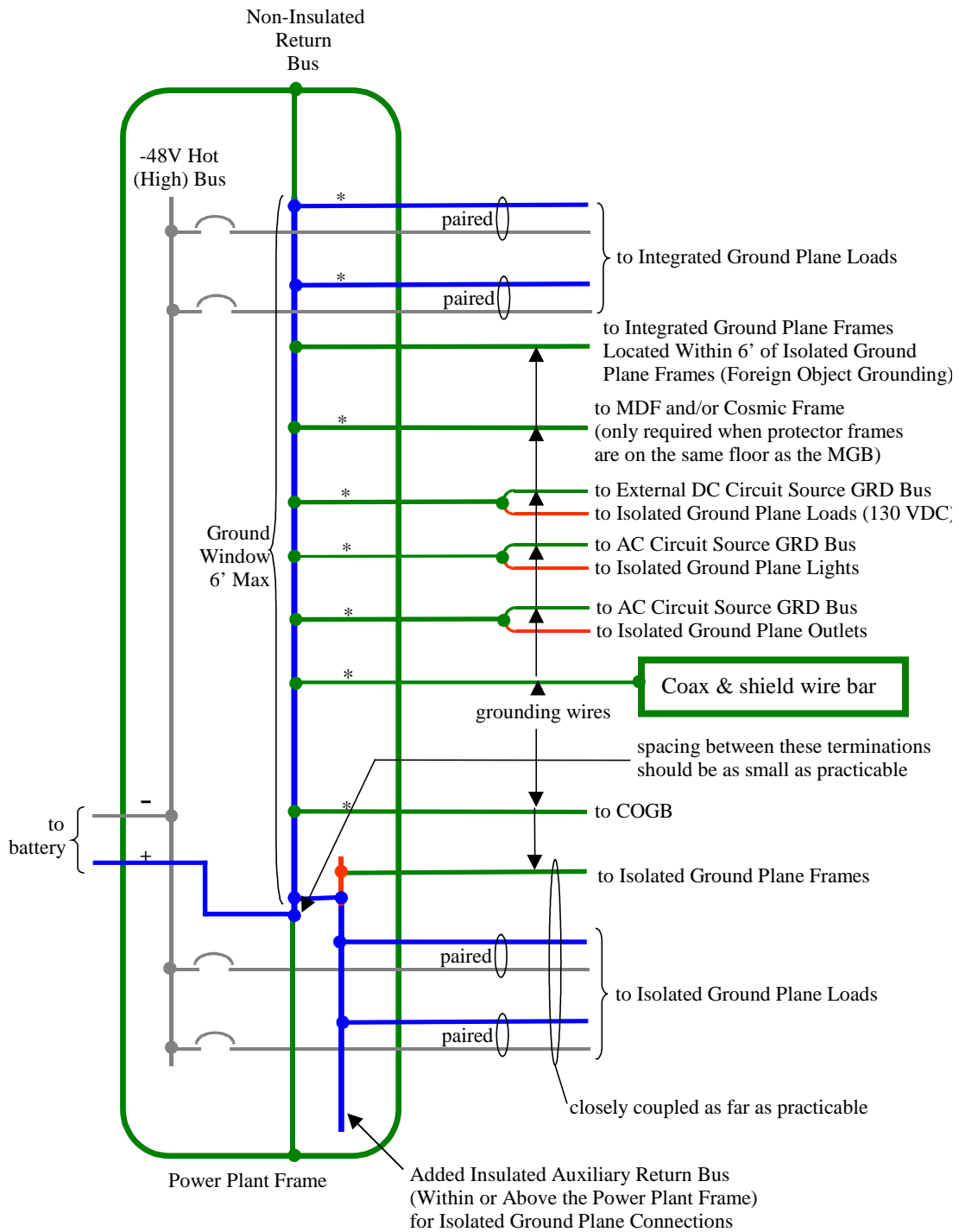

* Indicates Wires that Can Conduct Lightning or Fault Currents Into and Out of the Ground Window

Figure 8-10: Using a Noninsulated Return Bus as the Ground Window

- Make all required connections to the MGB within the ground window that involve grounding of external power supplies, grounding of frames, connections to certain return conductors, and connections to AC power grounding conductors. (Also, connect all integrated ground plane members within 6 feet of the isolated plane to the MGB per the guidelines in Section 8.10.3.)
- Run paired power leads from the principal power plant to each PDC (or equivalent) in the isolated ground plane that are closely coupled to the plant's frame and system grounding conductors. Do not connect return conductors to the main ground bus in the ground window, unless the power return bus is used as the ground window.
- Run other required external sources of power to the isolated ground plane. The grounding conductors associated with each of these sources shall be routed through the ground window and bonded (tap-connected) to the MGB.
- Ground the output of all internal power supplies and frames as required herein.
- Connect peripheral equipment to the isolated plane as required per this document.
- Run required prepower tests.
- When all these conditions have been satisfied, power up the equipment.

8.21 Performance Verification and Test Procedures

Note: All instrumentation used in the tests described in this section shall have a readout accuracy within a tolerance of 5 percent.

8.21.1 Visual Test

Visually inspect the isolated ground plane for observable violations such as loose connections, improper conductor sizes, and improper or poor connections.

Conduits and cable racks that have become part of the isolated ground plane by being routed through the ground window and connected to the MGB shall not be in contact with any other elements of the integrated ground plane.

Peripheral equipment frames that are part of the isolated ground plane shall not be in contact with any elements of the integrated ground plane.

Peripheral equipment that is part of the isolated ground plane shall be powered from sources within the isolated ground plane.

Internal and external power supplies shall be checked to see that they are grounded as required.

8.21.2 External Power Supplies

All DC power supplies serving an isolated ground plane switch shall be grounded at the MGB within the ground window.

All separately-derived AC power supplies originating outside an isolated plane, but serving an isolated plane shall be grounded at their immediate output, then have their ACEG and metallic conduit bonded to the ground window MGB integrated side, then have the metallic conduit isolated the rest of the way into the switch.

Isolating (orange triangle-marked) receptacles are prohibited going forward unless it is an extension of an existing isolating orange-triangle convenience outlet system.

8.21.3 Internal Power Supplies

All internal power supplies shall be grounded at the signal reference bus (see paragraph 8.17)

Ground Window Conductors - Check that all required conductors are connected to the ground window (see Figure 8-6 and Table 8-1 for a checklist). Check for the following:

- Wire Size
- Two-holed Crimp Connectors
- Tightness of Connections
- Conductors are Stranded Copper
- Condition of the Connecting Surface
- Separation of Integrated and Isolated Ground Connections

Listed Label and Wiring - Each AC power system component in the isolated ground plane shall be checked to ensure that it is listed by a Nationally Recognized Testing Laboratory, labeled and that the wiring is in accordance with the NEC.

Power Feeds - Check to determine that the power feeds are properly paired and that the return conductor is not connected to the MGB within the ground window.

Continuity Test - Check all raceway fittings and frame parts for continuity. Insulated fittings in raceways and painted connection surfaces shall not be permitted.

Inverters in the isolated plane shall only feed loads in isolated ground planes.

8.21.4 Insulation Test

Each frame (or group of frames) that is part of the isolated ground plane shall undergo the following insulation tests after being secured to the floor. This shall be done before connecting any power or grounding conductors to the isolated ground plane. These tests ensure that the necessary insulation has been provided between the hold-down fasteners and the integrated ground plane. When growth frames are added, the tests must be done before the frame is connected to the adjacent frame or overhead cable rack system.

Low-Voltage Resistance Test - Connect a low-voltage ohmmeter between each frame (or group of frames) and the MGB within the designated ground window. Measure the resistance. The resistance reading shall be 100,000 ohms or greater.

High-Voltage Resistance Test - If the frames pass the low-voltage resistance test, connect a 500-volt megohm meter between the lower part of each frame (or group of frames) and the MGB within the designated ground window to measure the resistance. The resistance shall be 100,000 ohms or greater, and preferably greater than 2 megohms. Test the lower part of the frame instead of the upper part to prevent equipment damage if the insulation breaks down.

The "isolation" and insulation of an existing isolated ground plane can alternatively be tested with a clamp-on resistance meter (CORM). Using procedures found in Telcordia BR 802-010-100 (or the CORM manufacturer's documentation), radial conductors to the isolated frames can be tested. They should read high resistance (open circuit). This method can even be used on individual frames that are not mesh bonded.

8.22 Isolated Ground Plane Noise Circuit Test

8.22.1 Abnormal Current Flow in Grounding Wires and Frames

While the telecommunications systems are up and operating, clamp-on ammeters that can detect AC and DC current flow (in the range of milliamps to Amperes) may be used to search for and help eliminate noise current flow in all grounding conductors and reference buses.

Under practical conditions, some circuit arrangements can cause current to flow in these conductors. Tests can identify the amount of current flow on the ground paths and, if necessary, remedial circuit arrangements can be made.

As a general rule, no more than 5 A DC or 100 mA AC total should be flowing to or from isolated switch frame grounds (in aggregate) or logic grounds, and it should normally be much less than that (no more than 1 A DC on any individual lead). Older switches were usually radially frame and logic grounded, whereas with modern switches, the frames (or logic) grounds are often mesh bonded within the isolated plane. When measuring for current with a mesh bond isolated system, care must be taken to ensure that all frame or logic ground conductors going from the MGB are encircled by the jaws of the clamp-on ammeter or resistance meter.

8.22.2 Correctly Wired Circuit Arrangements

To meet Federal Communications Commission (FCC), Electro-Magnetic Interference (EMI), and Radio Frequency Interference (RFI) requirements, various types of filters (from feed-through capacitors to complicated pi-connected types) are used. All or part of each filter is often connected from the line to a frame, completing a circuit that causes current to flow in the frames. To avoid such currents, it is desirable to connect these devices from line-to-return conductor rather than line-to-frame.

If portions of the filter still must be connected from line-to-frame to meet FCC requirements, the shunting devices to the frame should be closely inspected to determine the highest impedance it can have while still performing the filtering functions.

In any case, no single filter shall inject more than 3.5 milliamperes (AC or DC) into the frame.

8.22.3 Correcting Improperly Wired Circuit Arrangements

The following circuit arrangements shall not exist within the isolated ground plane:

- Multigrounded AC and DC power sources – This test concerns downstream interconnections between the AC neutral and the ACEG, or between the -48 volt return and the equipment frame.
- Test to determine if these sources are multigrounded by making a low-voltage measurement on an operating circuit between the return conductor of the source and a nearby frame downstream from the point at which the power source has been properly grounded. If the voltage measured is less than 0.1 V, multigrounding generally exists. If the voltage measured is greater than 0.1 V, then it is unlikely that multigrounding exists. This test should be performed at the following locations:
 - **For AC Circuits:**
 - At selected general-purpose receptacles on the frame
 - At the AC input to lighting fixtures that are part of the isolated plane

- **For DC Circuits:**
 - At the PDC
 - At the input to a converter
 - At the input to an inverter
 - At connector wiring that permits connecting a strap between the -48 volt return conductor and the frame ground

8.22.4 Overvoltage Protectors

All overvoltage protectors should be connected from the line to the return conductor(s). When an overvoltage protector is incorrectly connected from the line-to-frame, current is injected into the isolated ground plane. Therefore, the line-to-frame connection shall not be used.

In cases where downstream circuit insulation could be stressed by overvoltage conditions that appear between the return conductor and the frame, an additional protector should be connected from the return conductor to the frame. Thus, with two protectors connected, one from line-to-return and the other from return to frame, no current is injected into the isolated ground plane.

8.22.5 Improper Load Connections

Loads that are wired between line and ground (rather than between line and return conductor) inject large amounts of current into the isolated ground plane. This type of load wiring shall not be used.

When any AC or DC current is found flowing in any of the grounding conductors, it is an objective that the above circuit violations be investigated, located and corrected.

8.23 Distributed DC Power Plants in the Isolated Ground Plane

Small distributed DC power plants may be placed in the isolated ground plane switch footprint instead of PDCs. There are 3 cases where this can be done:

- 1) small switch needing only 1 PDC or distributed power plant
- 2) large new switch with multiple PDCs or distributed power plants
- 3) existing switch with multiple PDCs and a remote ground window

If the switch is small enough to need only one distributed power plant the distributed plant can be placed and function like a PDC. It must be isolated from the floor like any isolated ground plane bay. The plant should be equipped with an external return bus (tied to the internal returns) functioning as a ground window. The external AC feeds for the rectifiers must run through the window and have the conduits and ACEG conductors bonded to the integrated side of the MGB. Nearby (within 6 feet) metallic objects that are part of the integrated plane must also be bonded to the integrated side of the MGB. The frame ground of the plant is with a 1/0 AWG to the isolated side of the MGB. Just like all other MGBs, this one is connected to the nearest COGB with a 750 kcmil cable. No frame ground should be run directly to a COGB (the fault path must be through the MGB).

If a small switch fed from a distributed plant outgrows its capacity, or a large switch is placed to be fed from distributed power, only the first plant has an external ground window. Each successive distributed plant in that isolated ground plane does not have an external return. Instead, its internal return bus is ground referenced to the original MGB (isolated side) with a 1/0 AWG cable (in addition to the frame ground 1/0 that must also be run from this bay to the MGB). The AC conduits and ACEGs feeding the additional distributed power plants must be run through the ground window and bonded to its integrated side. After that point, the conduits must be insulated from contact with integrated ground plane members as they travel towards their power plant in the isolated plane.

Existing switches fed from centralized DC plants should generally not use distributed power plants for growth. And in fact, they cannot use them at all unless there is a remote ground window. In those cases, the new distributed plant will not have its own external return bar, but will connect to the existing remote ground window (isolated side) from their return bar with a 1/0 cable (in addition to the frame ground 1/0). Feeding AC conduits and ACEGs must also be bonded to the MGB integrated side.

CONTENTS

Chapter and Section	Page
9. Grounding Methods	9-1
9.1 Frame Grounding.....	9-1
9.2 Conductor and Connection Requirements.....	9-1
9.2.1 Girdling	9-3
9.3 DC Power System Grounding (for PDCs).....	9-4
9.4 Isolated Power Plant and Integrated Ground Plane Equipment Application.....	9-4
9.5 Ground Window	9-5
9.6 Establishing a Separate Ground Window	9-10
9.6.1 Dimensions	9-11
9.6.2 Locations	9-11
9.6.3 Ground Window Connections	9-11
9.7 Separation of Isolated Plane Metal from Integrated Plane Objects	9-11
9.8 Typical Bonds from the Ground Window Bus	9-12
9.9 PANI Concept.....	9-13

Tables

9-1 Tabulation of Typical PANI Bar Connections	9-17
--	------

Figures

9-1 Maximum Multifloor Ground Plane Spread Using a Single Power Plant	9-6
9-2 Digital Switch Isolated Power Plant Application.....	9-7
9-3 Ground Window Busbar Configurations.....	9-8
9-4 PANI Example.....	9-13

9. Grounding Methods

9.1 Frame Grounding

Figure 8-3 illustrates the typical overall frame grounding methods used in a digital and/or remote central office building. It shows how the isolated ground plane fits into the total grounding plan for the building. The following framework grounding arrangements, detailed below, are applicable to all digital installations:

- All isolated ground plane equipment frameworks shall be insulated from contact with other integrated ground plane conductive elements in the building. This includes, but is not limited to, metallic objects, floors, and walls.
- The Power Distributing (PD) cabinets (these have different names depending on switch manufacturer; such as PDF, PDC, etc.) shall be bonded directly to the MGB within the ground window with a 1/0 AWG conductor (this does not mean that each individual PD frame must have its own direct connection to the MGB – they can be simply connected to the serial or radial stringer).
- All other equipment frames or cabinets shall be bonded by a No. 6 AWG copper conductor to a grounding conductor that is routed along the top of each equipment lineup.
- Isolated ground plane equipment lineups shall be interconnected with a minimum No. 6 AWG copper conductor to a frame ground bar or a grounding copper conductor (typically a No. 2 AWG lineup feeder or “stringer”) which are bonded to the MGB within the ground window.

9.2 Conductor and Connection Requirements

Normally, grounding conductors do not conduct normal load currents. They shall conduct line to ground fault and lightning currents only. The impedance of any particular grounding conductor path shall be low enough to permit at least ten times the rated current of the circuit's associated protective device to flow when line-to-frame faults occur. The calculations that determine the impedance that meets this condition shall be based on the longest possible fault current path and the lowest working circuit voltage applied. All fault-path conductors must be large enough to carry the required fault current without thermal damage to the conductor.

The grounding conductors shall be routed in paths that are as direct and straight as possible, without any sharp changes in directions. If the direction must change, it shall do so gradually with a minimum curvature radius of 8 inches (12 inches is desirable). The grounding conductors shall be run exposed (visible and accessible). Connections to grounding conductors should be made so that the conductor flows toward the ground source wherever possible.

Single grounding conductors (conductors that do not have associated phase [hot] or neutral [return] leads) shall not be run in metallic enclosures. Further, the metallic clamps used to hold down grounding conductors shall not completely surround the wire (some exceptions are allowed – see Section 9.2.1). Examples of this type of conductor are vertical equalizers (illustrated in Figure 8-3) and the AC power grounding electrode conductor (illustrated in Figure 8-7). These types of conductors passing through the floor of a building shall be enclosed in nonmetallic sleeves for mechanical insulation and fire prevention.

DC Grounding conductors (as opposed to the grounded return conductors) shall not be run on cable racks. They may be secured to the side of cable racks, run on hangars, or any other approved method that makes them visible, as detailed in the Grounding section of CenturyLink Technical Publication 77350. Generally, DC grounding conductors may be run near each other regardless of the equipment they are grounding, unless specifically prohibited by an equipment manufacturer.

All ACEG conductors shall be insulated and identified with a green color. The size of the ACEG shall be in accordance with NEC Tables 250.66 (for ground electrode conductors) and NEC 250.122 (for equipment grounding conductors). It is preferable that ACEG splices are done with compression connections; however, they are governed by the NEC, and not held to the same strict standards as the DC grounding system.

All splices, joints and the free ends of conductors shall be covered with an insulation equivalent to that of the conductors or with an insulating device suitable for the purpose. Non-conductive coatings (such as paint, lacquer, and enamel) on equipment to be grounded shall be removed from threads and other contact surfaces to assure good electrical continuity.

Conductors shall be lightly coated with an appropriate anti-oxidant compound before crimp connections are made. All unplated connectors, braided strap, and busbars shall be brought to a bright finish (bringing a busbar to a “bright finish” includes removing any oxidation by cleaning it with a non-conductive abrasive product) and then lightly/thinly coated with an anti-oxidant before they are connected. Tinned or silver-plated connectors and other connection surfaces do not have to be prepared in this manner. All raceway fittings shall be tightened to provide a permanent low impedance path.

Multiple connectors shall not be secured by the same bolt assemblies except on opposing sides of the bus bars (back-to-back with the bus bar in between). Multiple conductors are permitted only in a bus arrangement when two single conductors are placed on opposing sides of the busbar using a 2 hole bolted connection. The stacking of two or more connections under the same bolt assembly and on the same side of a busbar is prohibited.

9.2.1 Girdling

Girdling refers to the encirclement of single grounding conductors by a ring of ferromagnetic metal. This occurs in these typical situations:

- Steel frames and cover plates used where conductors pass through holes in floors
- Steel cable-hole liners and conduit used where conductors pass through floors or walls
- Steel conduit used for physical protection of conductors
- Steel rings used for supporting conductors

An induced voltage appears along the length of conductors when they carry lightning surge currents. Ferromagnetic girdling contributes an additional (undesired) induced voltage; however, new calculations, which include this effect, indicate that the increase in magnitude of the induced voltage is much less than previously thought. Experiments support this result. The recommendations pertaining to girdling are as follows:

- Steel frames (up to 6 inches high), and cover plates used at floor or wall penetrations (where the frame is less than 8 inches in depth into the wall or floor) contribute negligibly to induced voltage and may be used without restriction.
- At locations where conductors pass through wall and floors, nonmetallic liners or conduits are preferred. If metallic liners are used, aluminum is preferred; however, steel liners and conduit in lengths up to 3 feet may be used where necessary (where grounding conductors in conduit already exist, the 3 foot rule is waived, as long as the conductors are end-bonded), since their contribution to increased induced voltage is small. "End-bonds" between the conduit and the conductor shall be made (the bond jumper size must equal the size of the enclosed conductor per NEC 250.64E, 250.66, and 250.104C). Because of their larger diameter, liners contribute less induced voltage than conduit, so bonding to liners is not necessary. Where fire codes require metallic liners, a metallic liner with an insulator gap is preferred.
- Other applications where runs of steel conduit enclose single grounding conductors should be avoided. Bonding of the conduit to the single grounding conductor at both ends is still required (bond using a pipe clamp, and a conductor sized at either the same size as the enclosed conductor, or having an equivalent cross-sectional area to the cross-sectional area of the conduit metal).

- Fully closed steel supporting rings may cause significant induced voltage when the rings are closely spaced (e.g., at 12-inch intervals), so steel rings shall be avoided going forward. "Gapping" a steel ring with fiber bolts is recommended. Rings of nonmagnetic material are preferred. Fiber rings, PVC rings, Steel J-hooks or other similar devices are acceptable grounding conductor supports.

9.3 DC Power System Grounding (for PDCs)

The battery return busbar of PDC cabinets (or similarly named switch secondary distribution points) is electrically isolated from the PDC framework. Splice plates located above the PDCs may serve as a convenient terminating point for the DC power return leads, which are generally large, since they are governed by voltage drop restrictions. A number of smaller leads, sized for ampacity, may be run directly to the individual discharge apparatus within the PDC frame. The use of splice plates is not a requirement. For small installations in which the power plant is located in close proximity to the digital switch, the primary battery distribution feeders may be run in pairs directly to the PDC frame. For installations which require two or more PDCs or where the power plant is located at a distance which makes it necessary to use large or multiple conductors to meet voltage drop constraints, splice plates are required.

9.4 Isolated Power Plant and Integrated Ground Plane Equipment Application

The following is required when an isolated battery return DC power plant is used to power both the Digital switch and other transmission and miscellaneous equipment that is part of the integrated grounding system:

- A ground window should be established at a convenient location for connecting both the AC conduit serving the isolated ground plane and the DC distributing return leads serving the integrated ground plane equipment. There should be no more than one floor separation between the ground window and the digital switch (see Figure 8-8).
- A physical separation of 6 feet should be maintained between the isolated ground plane frameworks and the frameworks of integrated grounded system equipment, when possible, to avoid the possibility of personal contact between the two ground systems.
- A grounding conductor shall be connected (referenced) between the digital switch framework and the MGB within the ground window.
- A Dedicated 750 kcmil Grounding Electrode Conductor shall connect the power plant battery return bus to the MGB within the ground window. The primary battery distribution feeders shall be run in pairs and closely coupled directly to the PDs of the digital switch.

- The Main Ground Bus (MGB) of the ground window shall be bonded to the CO GRD bus or OPGP (whichever is easier) on the same floor with a 750 kcmil conductor.
- The DC power plant framework, metallic battery stands, miscellaneous frames in the PBD lineup, and rectifier cabinets shall be bonded to the CO Ground bus on the same floor. The power plant framework shall also be connected to the MGB within the ground window
- To assure positive operation of overcurrent protection devices within the DC power plant in the event of a battery plant frame fault, size of the conductor will vary depending on the length and ampacity, and should run directly from each DC distribution frame to the MGB within the ground window (refer to Figure 9-2).
- All DC feeders serving systems in the integrated ground plane shall be routed through the ground window and bonded to the MGB.

9.5 Ground Window

The ground window (also known as the Single-Point Connection Window or SPCW; or in the case of some CenturyLink or NNS sites, a PANI bar or its GWB extension from the I section) is a dimensional transition zone consisting of a sphere with a maximum 3 foot radius. This is the interface between the building's integrated ground plane and a given isolated plane. It is the opening (a window, if you will) where all AC and DC grounding conductors (including metallic raceways) serving an isolated ground plane "see" their last connection to the building's integrated ground plane before they are connected to the isolated ground plane frames. Any bond or connection to the MGB shall be within three conductor feet of the center point of the sphere (see Figure 8-6). Any number of individual isolated equipment subsystems may exist in an isolated plane and can be referenced to a single ground window. After passing through the "window" and being bonded to the MGB, all of the grounding conductors (not to be confused with return conductors) associated with the isolated plane are insulated from the integrated plane because they have become a part of the isolated plane. Conductors serving integrated ground planes that multiground the return side of the principal power source and are energized from the same power plant serving the isolated plane must be routed through and connected to the MGB within the ground window.

Figure 9-1 illustrates the maximum number of floors over which one or more isolated switches served by a common DC power plant may be located. It also shows a method of bonding used to form a common ground plane that is isolated from the integrated plane, except for a single bond connection to the CO GRD bus on the center floor.

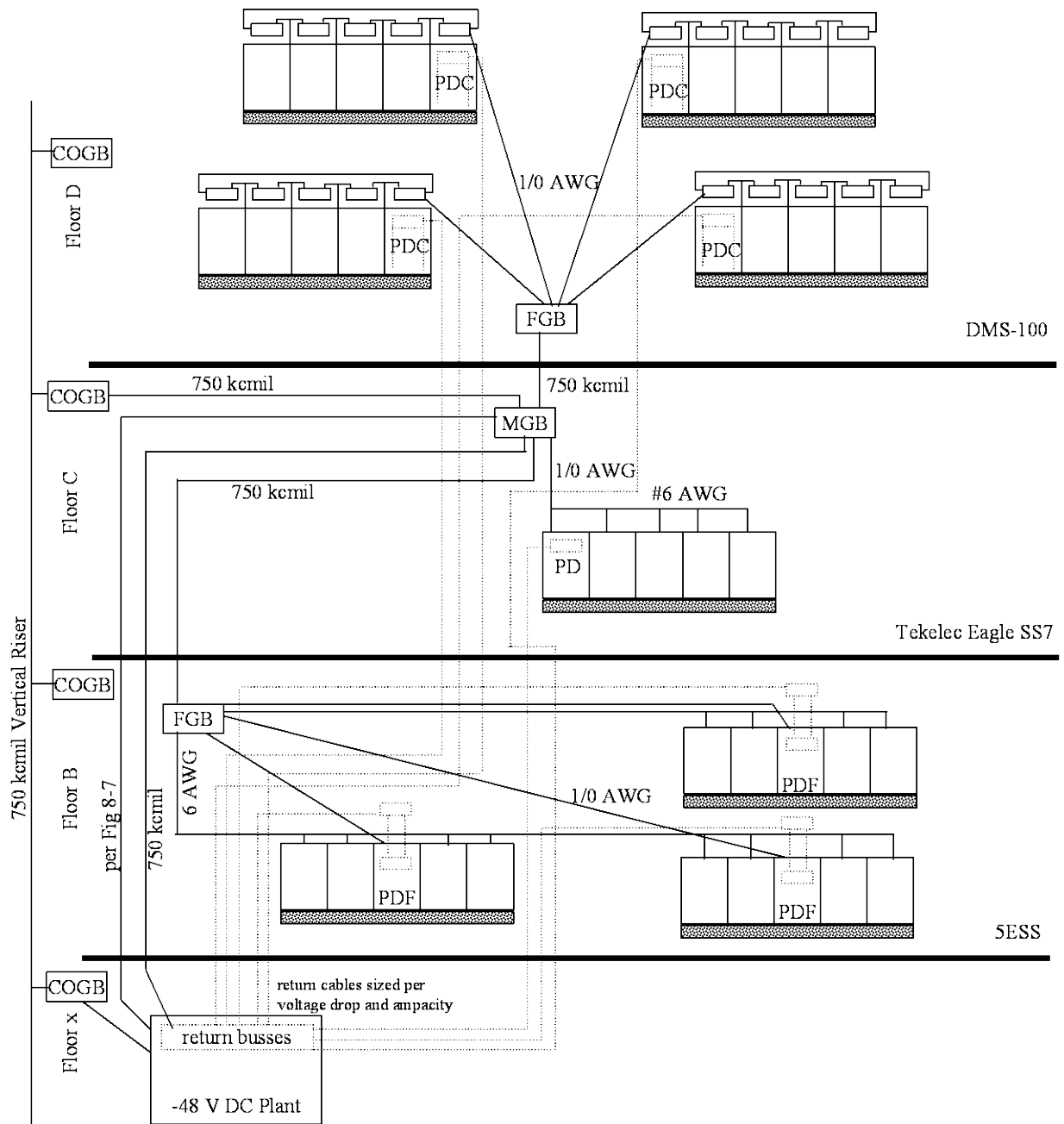
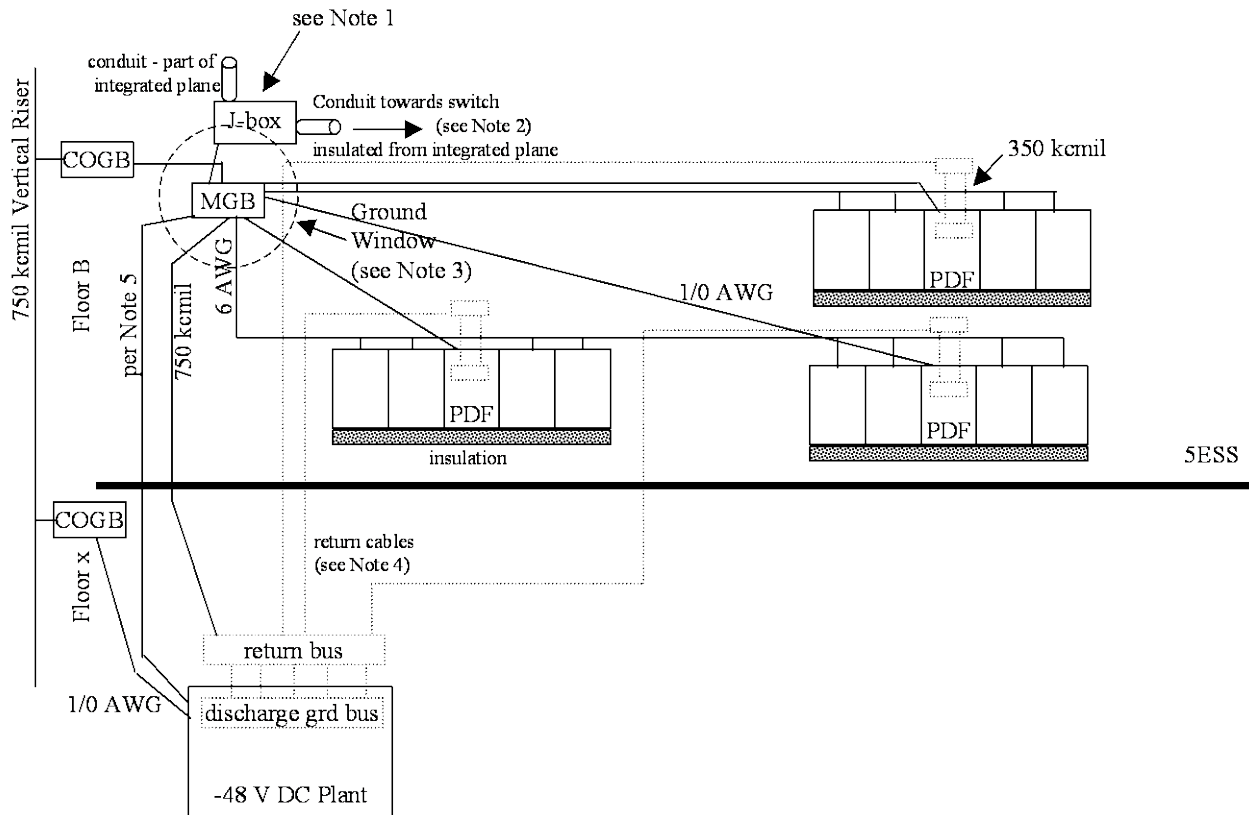

Figure 9-1: Maximum Multifloor Ground Plane Spread Using a Single Power Plant



Notes:

1. ACEG (Green Wire) and its metallic raceway must be connected to the Ground Window, and treated as part of the Isolated Ground Plane downstream from the Ground Window.
2. Conduit must be insulated from the Integrated Ground Plane from this point on, and be electrically continuous from the source of the loads.
3. The Ground Window shall be located as closely as possible to the Isolated Ground Plane(s) it serves. Vertically, it shall be no more than one floor from the Isolated Ground Plane.
4. The Plant Discharge Feeders (-48 V Return) are sized to meet system requirements and are run paired with the -48 V feeders.
5. The conductor between the MGB and the Power Plant Frame should be a minimum of 1/0 AWG up to 50', 4/0 from 50' to 100', 350 kcmil from 100-150', 500 kcmil from 150-200', and 750 kcmil for longer distances.

Figure 9-2: Digital Switch Isolated Power Plant Application

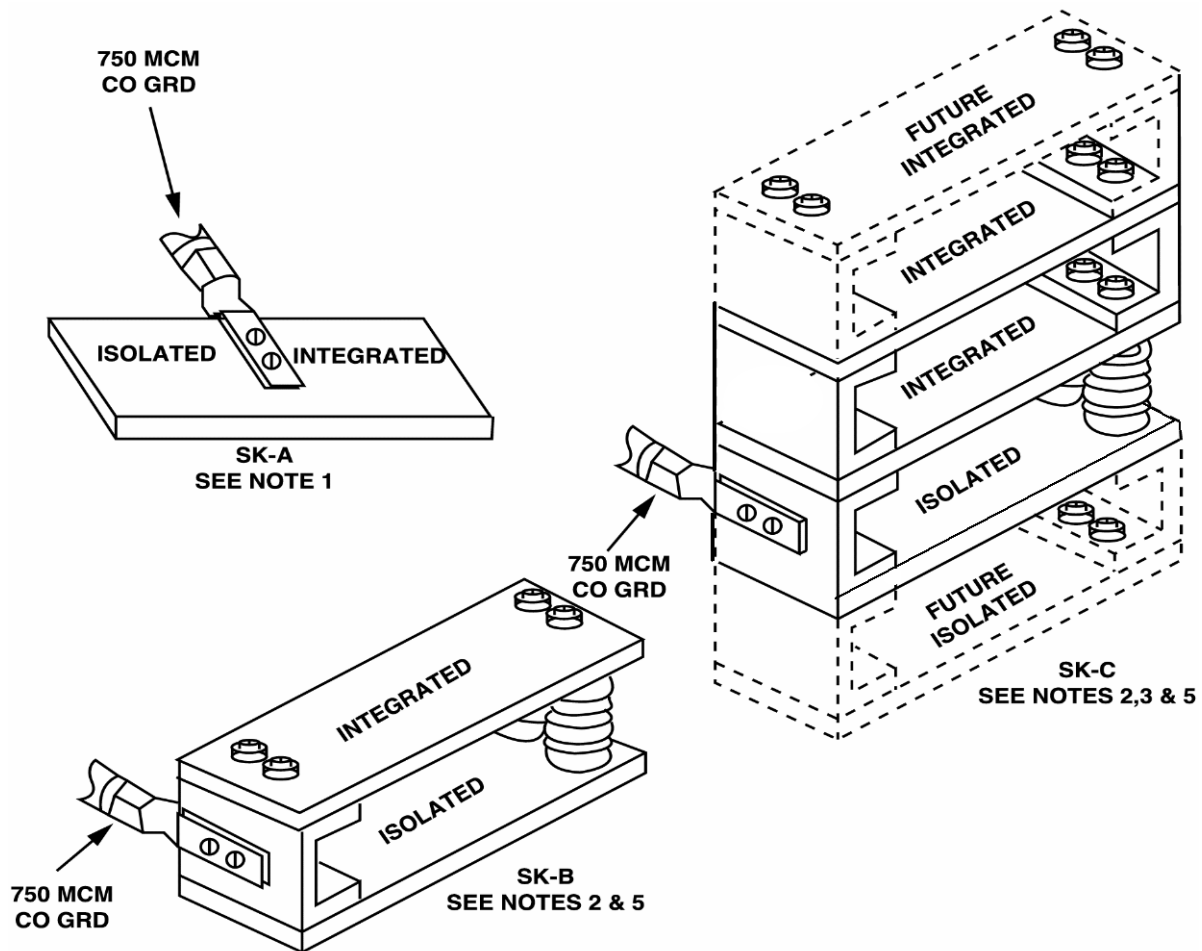

Notes:

1. The 750 kcmil conductor to the bar may be located at any point, so long as the isolated and integrated connections are on opposite sides of the 750 kcmil.
2. When 2 or more bars are used for the MGB in the ground window, the 750 kcmil conductor shall be installed on the copper channel bus as shown in SK-B and SK-C.
3. When the MGB is installed in the ground window, space should be provided for future growth when it is anticipated that 3 or more bars will be used.
4. Each bar shall be stamped or identified by tag as to whether it is in the isolated or integrated zone.
6. When the battery return bus is used as the ground window, the copper channel bus must be sized to meet the power plant ampacity.
7. Although SK-C shows copper channel on both sides (excepting the area of isolated/integrated zone division), it is not necessary that it be done in this manner. It is also permissible to set up the bar in an "E" configuration (i.e., only insulators would be used on the right hand side). This allows the integrated side (which is limited to 6 linear feet) to be stacked up to 3 feet high with 3 foot bars extending to the right.

Figure 9-3: Ground Window Busbar Configurations

The following restrictions are necessary to protect solid state components and printed wiring boards from possible damage in case of a lightning stroke on the building or other voltage disturbances originating outside the equipment area served by the isolated ground plane:

- Only one single point ground may be utilized with an isolated ground plane.
- Under no circumstances shall any Stored Program Control Switch System (SPCSS) framework that comprises a portion of the isolated ground plane be more than one floor away from the ground window.
- These restrictions limit the spread of the SPCSS equipment to a maximum of three adjacent floors when the ground window is established on the middle floor. As shown in Figure 9-1, the SPCSS ground reference is extended between floors only by means of a 750 kcmil vertical equalizer conductor. There is no continuity, except through the ground window between the isolated ground plane on the upper and lower SPCSS floors. On the middle floor, only one bond connects the isolated ground plane to the integrated ground plane. This is shown as a 750 kcmil conductor between the CO GRD bus and the MGB within the ground window.
- The single point connection integrates the isolated ground plane with the integrated plane for the purpose of equalizing voltage between the otherwise isolated planes. The single point restricts current generated by a lightning stroke on the building from flowing through SPCSS frame members to earth. Additionally, current spikes generated by equipment operation or malfunction in systems that are not connected to the isolated ground plane cannot flow through that plane since at least two connections are required to complete a circuit.
- The ground window may be located in a position other than that described in paragraph 9.3. In a single floor SPCSS layout, it may be expedient to establish the ground window in a location that would facilitate routing of conduits or power ground feeders that must pass through the ground window. Where the power plant serves three floors, the ground window must be established on the middle floor. The main ground bus should be located in the SPCSS area, which in a 3-floor installation may be presumed to include any point of the middle floor that intervenes between upper and lower floor SPCSS installations. It may be mounted on cable rack, a column or a wall or other positions accessible for cabling. It should be noted that conduits and ACEG leads serving the SPCSS equipment must be bonded to the MGB within the ground window before extension to the SPCSS equipment on adjacent floors.

- If space for termination of ground leads on the MGB has been exhausted, supplementary ground buses may be installed. This bus shall be located within the 6 foot sphere of the ground window (i.e., within three feet of the MGB) and shall be connected to it with 750 kcmil conductors (if it's a remote ground window, only one 750 kcmil is required; however, if the MGB is also the power plant return bus, enough 750 kcmil conductors must be used to connect external bus to ensure that the required ampacity can flow through it) or preferably with a copper channel bus. Any ground leads that normally would be connected to the main ground bus may be terminated on the supplementary ground bus. A supplementary ground bus should not be used unless necessary.

The ground window with supplementary buses is constructed as follows:

- The main ground bus shall be the bus which contains the connection to the CO ground bar.
- Supplementary ground buses shall be connected to the main ground bus with 750 kcmil conductors or a copper channel bus (see Figure 9-3).
- When open ended supplementary buses are used, the distance of the bus from the center of the ground window to the open end shall be limited to 3 conductor feet (see Figure 9-3).
- Supplementary buses shall be configured so as to preserve the conductor segregation as specified in Figure 9-3.

9.6 Establishing a Separate Ground Window

A ground window, as previously defined above, shall be established to serve the isolated ground plane. A copper bus (or buses) called the main ground bus (MGB), shall be located within the ground window to provide a place where various required connections can be made. The main ground bus shall not be mounted on any of the isolated ground plane frames (see paragraph 8.18 for requirements when the principal power plants return bus is used as a ground window).

Note: The MGB in the ground window shall be clearly identified by stenciling or other means. The MGB isolated and integrated sections shall also be identified.

To prevent lightning and fault currents from other sources from flowing through the MGB, the MGB shall be mounted on insulators so as to insulate it from the building's integrated ground plane.

Only one ground window shall be associated with the principal power source serving the isolated ground plane. However, more than one isolated equipment subsystem may exist in an isolated ground plane and can be served by a single ground window (see paragraph 8.18).

9.6.1 Dimensions

The ground window's dimensions are that of an imaginary sphere with a maximum radius of three feet.

9.6.2 Locations

The ground window shall be located as close as possible to the isolated ground plane it serves. Vertically, it shall be no more than one floor from the isolated ground plane. Horizontally, the ground window shall be not further than 100 feet from the floor Central Office Ground (CO GRD) or 100 feet from the furthest member in the isolated ground plane. In no case, however, shall the furthest unit of equipment be more than 200 conductor feet from the floor CO GRD bus.

9.6.3 Ground Window Connections

A number of possible connections can be made on the MGB within the ground window, depending upon the needs of the various installations. Tabl 8-1 shows typical detailed connections. The MGB can be thought of as the transition point between the integrated and isolated ground planes. The sequence of connections shown in Figure 8-6 should be followed. No connections shall be made between the isolated ground plane and the integrated ground plane other than through the MGB. All conducting materials that are part of the isolated ground plane such as cable rack, and cable troughs, conduits, armored cable, enclosed conductors, and the SPCSS frames shall be insulated and kept insulated from the integrated ground plane.

9.7 Separation of Isolated Plane Metal from Integrated Plane Objects

Isolation of SPCSS equipment is accomplished by the use of insulators between points where metal work common to integrated plane must be fastened to metal work common to the isolated plane. Such points include:

- **Anchor bolts** – Analog or Digital equipment frame anchor bolts may come in contact with grounded structural metal in a floor. An insulator must be used to separate studs and bolt heads from frame metal.
- **Bottom of frames** – Insulating material shall be placed between frames and floor.
- **Superstructure supports** – This includes brackets extended above frames to support unistrut channels that support fluorescent lighting fixtures, conduits, and power cable racks that are part of the integrated ground plane. Insulators shall be placed on top of the support brackets to isolate the SPCSS (analog or digital) switch from the integrated ground plane.

- **Conduits** – Conduit (or other raceway) connected to analog or digital ground plane equipment (SPCSS) and supported from unistrut lighting support channels are insulated by means of fiber sheeting wrapped around the conduit or other appropriate insulating material at points of support.

When 500 V minimum rated insulation is not used, conductive members of differing potentials or different ground planes must be separated by at least 2 inches of air space.

9.8 Typical Bonds from the Ground Window Bus

The MGB/GWB within the ground window serves as the interface point between the isolated ground plane and the building integrated ground plane. In addition to a connection to the floor CO GRD bus, direct bonds of minimal practical length are required from the main ground bus to points on different objects comprising a part of the integrated ground plane ("foreign" object grounds). Use of such bonds ensures that the voltage difference between members of the two planes will be equalized to the greatest possible extent. Such equalization tends to reduce the incidence of sparkover between the two planes and possibility of shock hazard to personnel interposed between the planes.

In a typical SPCSS installation, the main ground bus is bonded directly to:

- The floor CO GRD bus (see Figures 8-6 and 9-2)
- Main Distributing Frame when on same floor as the ground window (see Figure 8-6)
- AC conduit and AC equipment ground conductors (ACEG) that serve the isolated ground plane (see Figure 8-6)
- Foreign object grounds within 6 feet of the SPCSS equipment
- Grounded conductors of power supplies to non-SPCSS equipment

Connection between the Main Ground Bus and the CO GRD bus is made with a green 750 kcmil insulated stranded copper conductor.

It is advantageous to keep the interbonding conductor at a minimum length. Where practical, the CO GRD bus and the main ground bus should be located close together.

In offices not equipped with a CO GRD system, a CO GRD system shall be installed.

Note: Sharp turns or bends should be avoided in grounding systems to minimize the inductive reactance that is introduced by steep wavefront currents. The higher reactance increases the included voltage and thus reduces the overall effectiveness of the grounding system. Minimum bending radius is 8 inches.

9.9 PANI Concept

In some NNS, and Legacy CenturyTel and Embarq (CenturyLink) facilities, the PANI (Producers, Absorbers, Neutrals, and Isolated conductors) concept was previously used (and does not have to be changed), as opposed to the OPGP, COGB, and Ground Window system described elsewhere in this document. The general idea is that there is only one main grounding bar used in small sites, regardless of label. In essence it serves as somewhat of a combination of the aforementioned bars. In multi-story buildings, there is a main OPGP/MGB, as well as individual floor FGB/COGB bars. Each of these bars in a PANI office is split into PANI sections. The sequence of connections can be reversed (INAP) if needed. An example is shown in Figure 9-4 below:

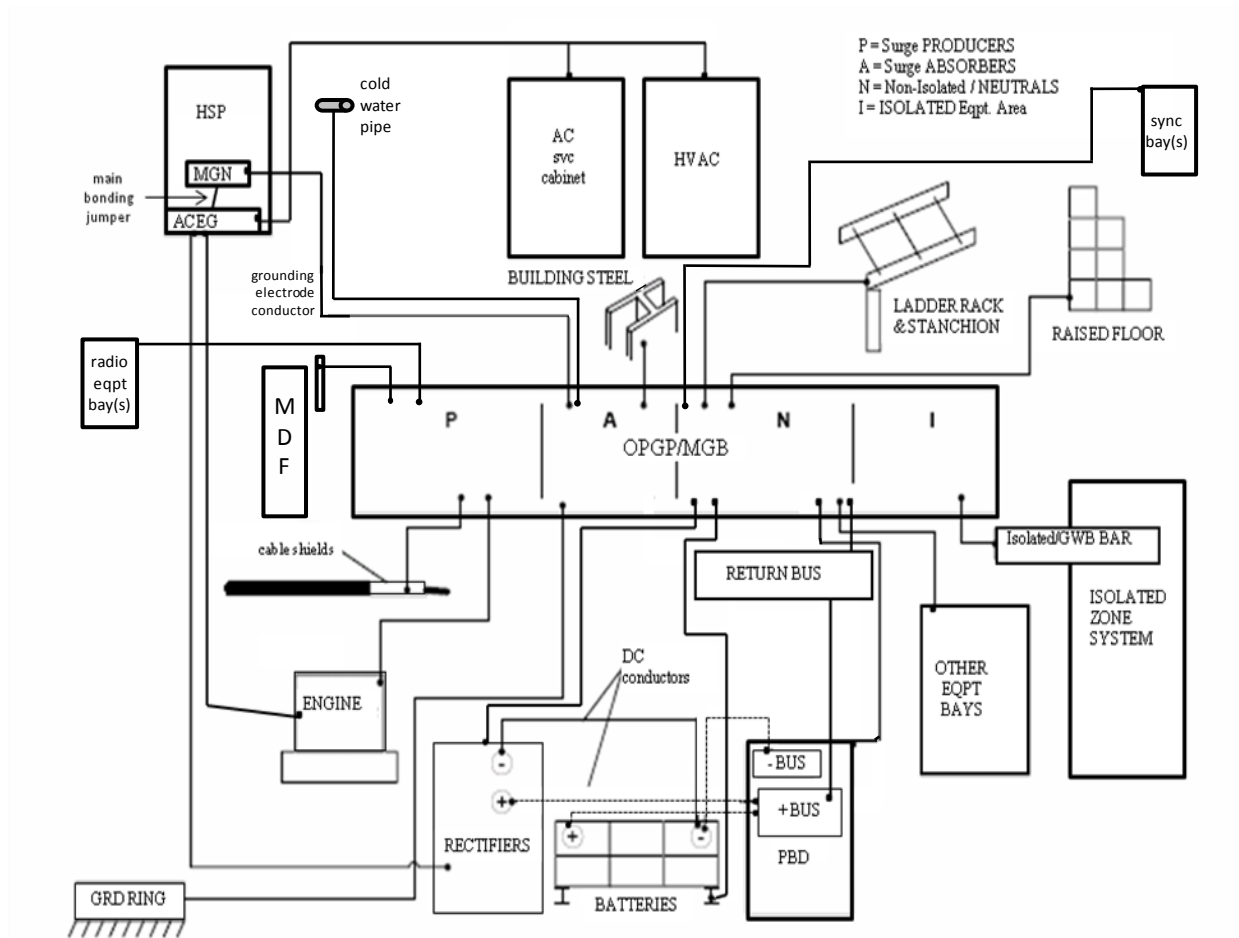

Figure 9-4: PANI Example

In the independent telco PANI concept, in addition to Class 4 and Class 5 switches (IGZ #1), some toll/transport frames may also be isolated from the floor and considered as their own network element isolated ground zone (IGZ #2). In these cases, there are usually at least two different ground window bars (GWB) that connect back to the Isolated section of the PANI bar. Even most of the non-isolated ground zone (non-IGZ) equipment may be isolated from the floor in the independent telco PANI concept.

In a PANI office, Class 4/5 isolated ground plane switches typically comprise an IGZ #1. Sometimes (depending on the switch manufacturer's design) a GWB bar (such as an FGB) is placed near the switch for connection of all switch frames, and the GWB is connected to the "I" section of the PANI bar with a minimum 2/0 AWG copper conductor having a maximum resistance of 0.005 Ohms. The switch manufacturer determines the size of the ground leads from the GWB to the individual equipment frames. When no GWB is used, a collector cable (minimum 2/0 AWG) may be run to the switch area from the "I" section of the PANI bar, with individual switch lineups/frames tapped to it, or multiple cables are run from the "I" section of the PANI bar to the switch area (once again, dependent on switch manufacturer design). Non-isolated ground plane metal within 6' of PANI office IGZ (see Section 8.10.3 for further detail) should be connected to the "N" section of the PANI bar (it may be first connected to a collection bar, such as a FOG or ICB) on the same floor.

Network elements in IGZ #2 may include equipment for transport, transmission, and DLC/DSLAMs when the equipment frame / relay rack is isolated from the floor and other central office metal (including cable racks and metallic conduit) in order to minimize electrical noise (particularly on high-speed circuits) since the manufacturers of this equipment typically do not require isolated grounding. Usually, there is a GWB for each IGZ #2, which is connected to the "I" section of the PANI MGB with a minimum 2/0 AWG. The aisle stringers for each lineup are also typically 2/0 AWG. A GWB is not required for single lineups, and the 2/0 aisle stringer can connect directly to the PANI MGB.

It is desirable that isolated ground planes be marked on the floor with orange tape.

Non-IGZ equipment includes long-lines IOF transport, most of the network elements described in the preceding paragraph (when they are not isolated from the floor and superstructure) subscriber carrier, DSX jacks, test heads/units, and all other equipment not classified as switch, sync/timing, or radio (power equipment, and the DC plant ground reference is typically connected to this "N" section as well). Each lineup is typically connected to the "N" section of the PANI MGB with a 2/0 aisle stringer; or for larger offices there may be a horizontal equalizer (possibly with a bar at the end of it) extended to a non-IGZ area for collection of aisle stringers.

Network sync/timing receiver equipment in the PANI concept usually resides in an isolated (from the floor, cable rack, and any other metal) relay rack. When connected to an external GPS antenna (see section 7.24 for guidance on grounding of GPS antennas), it is considered "P" equipment, but is connected to the "N" section of the PANI MGB due to the sensitivity of the equipment itself, and because it attaches to almost all other intelligent network elements (most of which are connected to the "N" or "I" sections of the PANI bar) to provide timing. This relay rack should be separately connected to the MGB "N" section with a 2/0 copper insulated lead adjacent to the "A" section (the first lead in the "N" section). In circumstances where space is not available to place the timing receivers in a separate rack, isolate the timing receivers from the relay rack framework, and separately ground that chassis to the "N" section of the PANI bar.

In a PANI site, CO ground electrode fields (COGF, as described in Chapter 3), such as an exterior ground ring, are typically tied to the MGB "A" section with a minimum of two #2 AWG solid tinned bare copper conductors. In cases where these conductors are brought into the cable vault instead, and tied to the CEGB, that is acceptable, as long as a 750 kcmil conductor connects the CEGB to the PANI MGB.

The MGN at the service entrance (see Chapter 4 for further detail on AC grounding) is connected to the "A" section of the PANI MGB. While Chapter 4 requires this conductor to meet the NEC minimum, for COs with Class 5 switches following PANI design, this should be a minimum of 2/0, to ensure RUS standards of 0.005 ohms for this connection are met.

Building steel is bonded to the PANI MGB "A" section.

In a PANI-designed site, cable racks may be isolated (or may not be) from building structure and supports and from relay racks and metallic AC conduit. Cable rack (including foreign object grounds [FOG or ICB] near the switch) is connected to the PANI MGB "N" section with minimum #6 AWG green-insulated copper conductors.

In PANI-designed sites, radio equipment usually resides in isolated relay racks, connected to the "P" section of the MGB, typically with a 2/0 AWG copper insulated lead. Coax and waveguides are grounded as described in Chapter 7, both inside and outside the building at the waveguide hatchplate / entry point.

Cable Entrance Facilities (see Chapter 6 for further information on CEF / cable vault grounding) in PANI-designed sites may or may not have a CEGB (Cable Entrance Ground Bar/Bus). When it exists, this bus is either tied directly to the COGF with a #2 solid, tinned copper conductor, or back to the PANI MGB "P" section with a 2/0 AWG insulated conductor. When this bus is non-existent a 1/0 or larger cable is run from the MGB PANI and extended the length of the cable entrance facility to serve as a pseudo-"bus" for cable entrance facility bonding (done with #6 AWG or bonding ribbon) from each cable shield.

The MDF ground bar (MDFGB) and the MDF ironwork (when isolated from each other) are connected to the MGB with 2/0 cables (to the “P” section for the MDFGB, and to the “N” section for the MDF ironwork). When the ironwork and the MDFGB are not isolated from each other, and/or when the protector block ground points are not isolated from the ironwork of the MDF, a single 2/0 AWG green-insulated cable is run from the MDFGB to the “P” section of the PANI MGB, and the MDF ironwork is isolated from other overhead ironwork in the site. When the MDFGB and the MDF ironwork are isolated from each other, and when the protector block grounds are isolated from the ironwork, the protector block grounds are typically daisy-chained to the MDFGB with #6 AWG with two-hole lugs where equipment design allows for it. In very tiny sites (including those with a pedestal CEF), the MDFGB may double as the PANI MGB.

In-building engine rooms are typically bonded to the PANI MGB in the “P” section (see Section 4.9 for further information on engine room grounding).

Absorbers and Producers should generally be routed as far away from Network equipment and signal-carrying cables as possible (for example, it is desirable to have radio bays at least 10 feet away from a switch) to avoid flashover and induced noise. It is also acceptable to have the Producers and Absorbers on a separate bar than the Neutral and Isolated connections, as long as the two bars are connected together with a 750 kcmil conductor.

The following table lists the typical connections to the various PANI sections (sometimes with the cables marked with the designation shown in brackets):

Table 9-1: Tabulation of Typical PANI Bar Connections

Section	Lead Types
P	Radio Equipment Cabinets [R]
P	Cable Entrance Ground Bar (CEGB) [C]
P	MDF Ground Bar [M]
P	Engine-Alternator Frame/Room
A	Central Office Ground Electrode Field(s) (COGF) [L]
A	MGN or delta neutral (or power company rod for ungrounded secondary deltas) [N]
A	Water Pipe [W]
A	Building Steel [B]
A	Vertical & Horizontal Equalizers and PANI FGBs
N	Timing Source Receiver RR or Chassis
N	MDF Ironwork
N	Collocation Ground Bars on the same floor
N	PICS Cabinet
N	Battery Racks
N	Power Bay Equipment (PBDs), including stand-alone Rectifiers [G]
N	non-IGZ Equipment [N ²]
N	Cable Rack and other miscellaneous metal
N	Battery Return Bus [N ¹]
I	Ground Window Bus (GWB) for non-Switch isolated ground zone (IGZ #2) [I ²]
I	GWB or conductor(s) for Switch isolated ground plane (IGZ #1) [I ¹]

CONTENTS

Chapter and Section	Page
10. Outside Plant Equipment Enclosures	10-1
10.1 Controlled Environmental Vaults (CEV's)	10-1
10.2 Other Controlled Environment OSP Enclosures (huts, CECs, UEs, etc.)	10-8
10.3 Above Ground Outdoor Type Cabinets/Housings.....	10-8
10.4 Grounding of the AC Neutral	10-11
10.5 Customer Premises Electronic Equipment Installation Grounding	10-13
10.5.1 Special Protection Requirements for Customer Premises Locations On or Near High Voltage Electric Power.....	10-15
10.5.2 Customer Premises Computer Room.....	10-15
10.5.3 Customer Premises Isolated Ground Planes	10-16

Figures

10-1 CEV Sectional View of Excavation and Ground Rod Installation	10-3
10-2 Typical CEV Excavation and Driven Ground Rod System	10-4
10-3 Typical CEV Bonding of Upper and Lower Housings.....	10-4
10-4 Typical Grounding Arrangement for CEVs.....	10-5
10-5 Typical Inside Grounding for CEVs.....	10-6
10-6 Examples of Grounding Schemes for Existing CEVs	10-7
10-7 Typical RT Site Where Most Structures are Grounded to a Common Bar	10-10
10-8 RT Site Structures Grounded to Ring When SAI Sheathes Isolated.....	10-10
10-9 Power Pedestal and RT Treated as One Structure	10-12

10. Outside Plant Equipment Enclosures

10.1 Controlled Environmental Vaults (CEVs)

For CEVs, a driven ground electrode system (MGE) as specified in Chapter 3 shall be installed (and possibly pre-engineered via soil resistivity measurements). After installing the ground electrode, the system should be tested and recorded prior to connecting the system to other ground electrodes. The resistance of the ground electrode system measured with an earth resistance test set (a clamp-on resistance meter should generally not be used for this measurement – see the guidelines in Section 3.1) should be 5 ohms or less. If a 5-ohm impedance cannot be obtained, contact the local CenturyLink Electrical Protection Engineer for assistance (in some cases, the 25 ohm maximum specified by the NEC may be the best we can get, and good enough).

(When OSP Equipment Enclosures [EEEs] such as CEVs, huts, or RT cabinets are placed within a quarter mile of an electrical substation, special grounding precautions may need to take place. Contact the CenturyLink Electrical Protection Engineer for assistance in determining ground rise potential, high voltage protection needs, and ground field considerations. In many of these cases we do not want to drive our own ground field, but tie to what is at the site only.)

The preferred CEV grounding method is to install a driven ground rod system underneath or adjacent to the CEV (see Figures 10-1 and 10-2). At the bottom of the CEV excavation, open a minimum 30 inch deep trench for the ground ring conductors. After installing the rods, #2 AWG solid wire, and connecting them, backfill the trench with removed dirt (don't backfill with gravel or sand). After the CEV is set in place, route the two #2 AWG ground conductors through the designated PVC conduits cast into the CEV wall. Place a moisture proof dam around the end of the conduit and the #2 conductor to prevent moisture from entering the CEV. (After the #2 conductors have entered the vault, they may be connected to stranded conductor, if desired.)

A ground bar shall be installed inside the CEV at a convenient location for ease of grounding of all equipment framework (some existing CEVs have only an interior halo ring ground, and upgrade to a main ground bar is not necessary at these sites). This ground bar will be a combination SPGPB and CEV Ground bar. The two #2 ground conductors shall be connected to the ground bar by crimping each conductor to a two hole copper connector and connecting them to the CEV ground bar (or alternately by exothermic weld).

After the CEV is assembled with upper and lower housing, electrically connect the two housings together by making a cable assembly and connecting to the upper and lower housing ground plates. The cable assembly shall be made with a #2 stranded tinned copper conductor. Exothermic weld, or crimp a two hole copper connector at each end and connect to the CEV ground plates with two bolts. Apply a non-oxidizing compound between the connector and the ground plate (see Figure 10-3).

On the opposite end of the CEV connect both upper ground plates to the interior ring ground or the lineup grounds (or the CEV main ground bar) with a #2 copper wire.

For new installations the ground connections required inside the CEV are (see Figures 10-4 and 10-5):

- Add a bonding jumper from the AC neutral bar at the service entrance, sized per the NEC (Article 250), and terminate it on the ground bar. Before doing this, ensure there is no MGN-ACEG bonding jumper in the power pedestal serving the CEV.
- Add a #6 bonding conductor from the AC distribution panel cabinet metal to the CEV ground bar or interior ring ground, or to the neutral bus in that panel.
- Add a #2 AWG conductor from the cable entrance for bonding of cable sheaths.
- Add a minimum #2 stranded copper conductor run along each equipment lineup (not necessary for lineups along the wall if there is an interior halo ground). Connect #6 stranded copper insulated branch cables from the #2 “stringers” for grounding individual frameworks.
- Add a minimum #2 ground reference conductor to the power plant battery return bar (+).
- Add a #6 ground conductor for grounding the power plant framework (this can be connected directly to the bar or to the lineup “stringer”).
- Add a #6 bond to the CEV’s metallic entrance hatch.
- Bond upper and lower sections of the entrance ladder to the #2 conductor with a #6. (Alternately, one connection can be made from the entrance ladder to the site ground system if the two sections of the ladder are bonded with a jumper.)
- Bond around flexible HVAC system ductwork with a #6 AWG stranded wire.
- Ground the protector frame cabinet and the splice cabinet with a #2 conductor.

Existing CEVs can be upgraded by installing a grounding electrode and bringing the inside grounding up to current grounding requirements. (Some of the oldest CEVs were Ufer grounded, but it was learned that without a sealant on the concrete, there was water seepage.) Consider the following items, and Figures 10-5 and 10-6:

- If the existing CEV doesn’t have a ground electrode, install one because the cement-encased electrode is not a reliable primary electrode. Add a ground electrode per Figure 10-6, depending on the site. If a driven rod system is installed, bring in two conductors from the ring into the CEV at two points apart from each other and connect to either a ground bar or to the interior ring ground. Two holes can be drilled on the upper housing for access inside the CEV. These holes must be properly plugged to prevent moisture from entering the CEV.

- Add a #2 stranded copper conductor interior ground ring halo on the inside wall just above the cable rack level, or run individual #2 stringers down each equipment aisle.
- Bond the #2 interior halo ring ground (or an aisle stringer) to each ground plate of both the upper and lower sections of the CEV.
- Bond the ring ground to the AC neutral at the service entrance with a conductor sized per the NEC.
- Ground the power plant's battery return bar to the ring ground using a #2 AWG stranded conductor.
- Ground each equipment frame with a #6 stranded wire using H-taps or C-taps and two-hole crimp connectors.
- Ground the Protector frame cabinet and the Splice cabinet with a #2 AWG conductor.
- Ground both sections of entrance ladder and the upper metallic entrance housing with a #6 stranded copper conductor.
- Bond the AC distribution panel to the interior halo ring ground, CEV ground bar, or an aisle stringer.

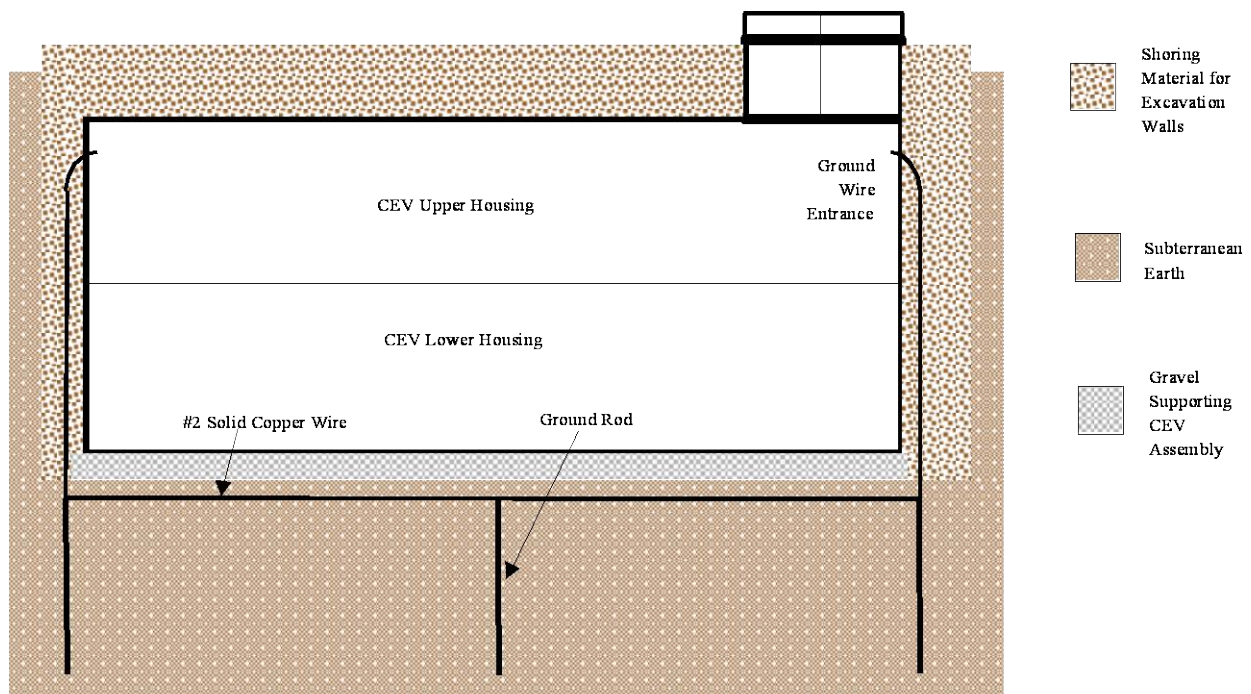

Figure 10-1: CEV Sectional View of Excavation and Ground Rod Installation

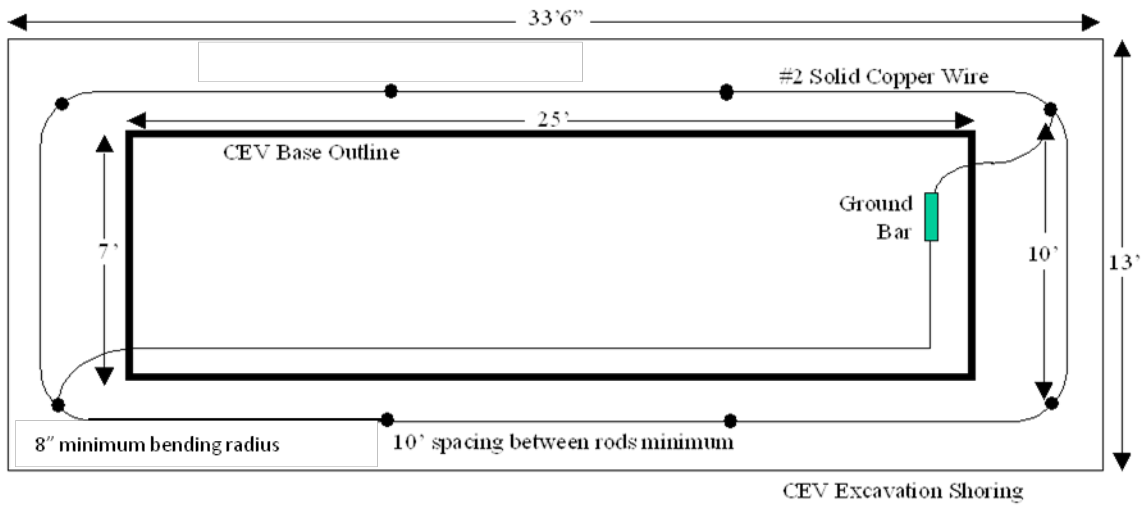

Figure 10-2: Typical CEV Excavation and Driven Ground Rod System

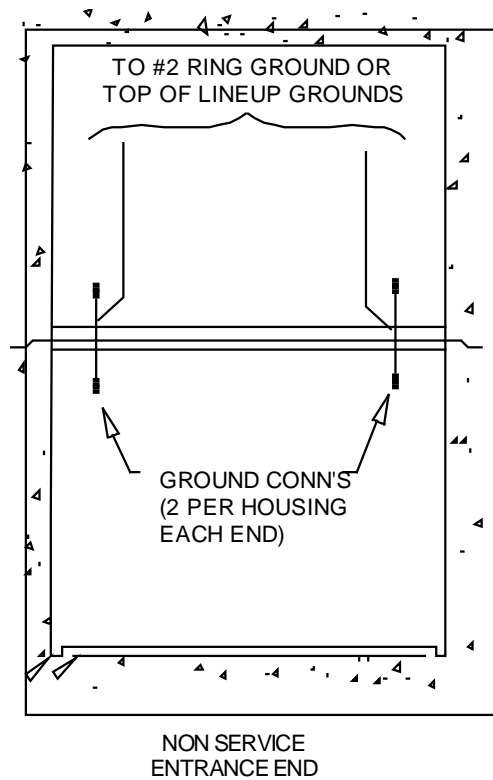
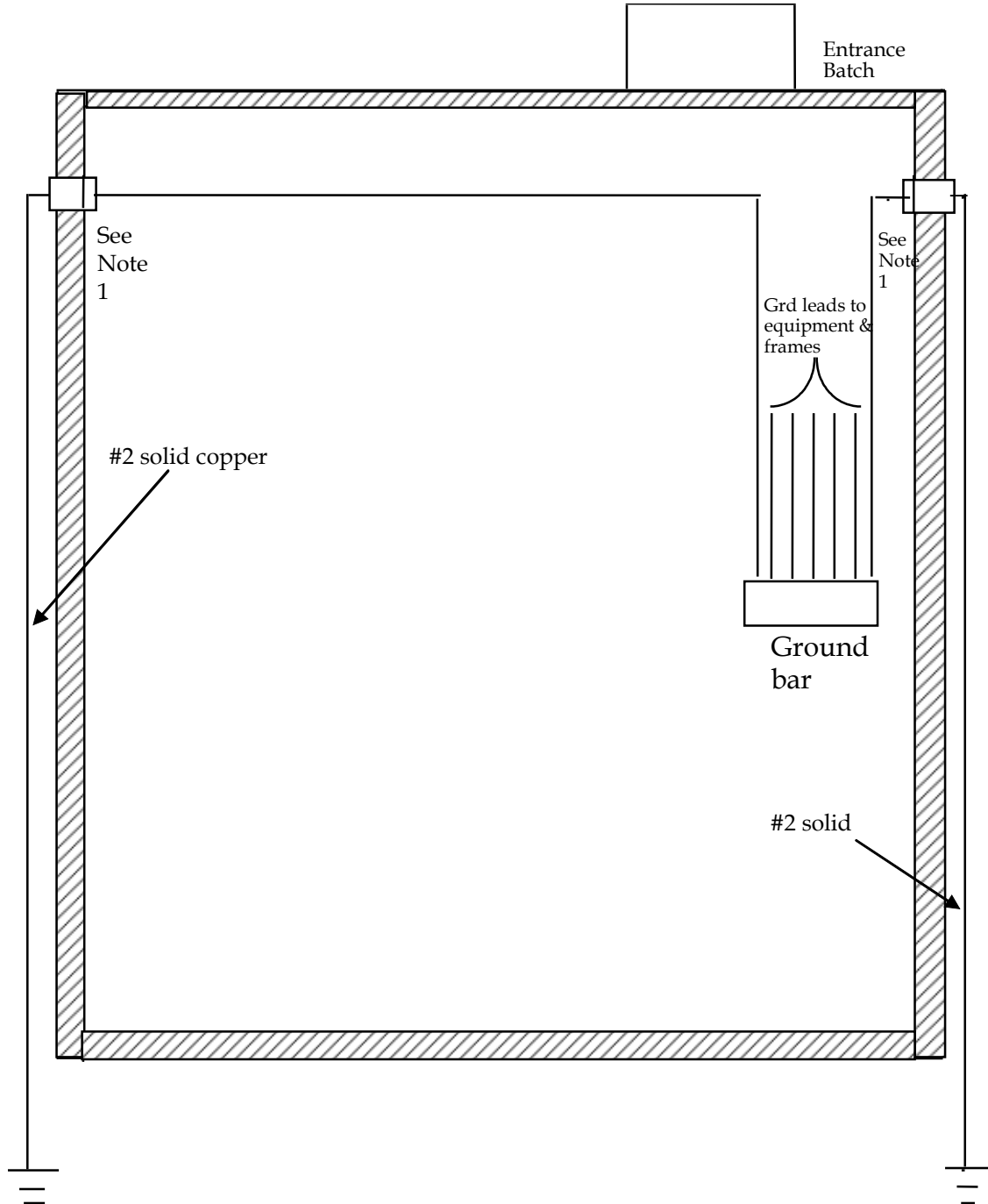
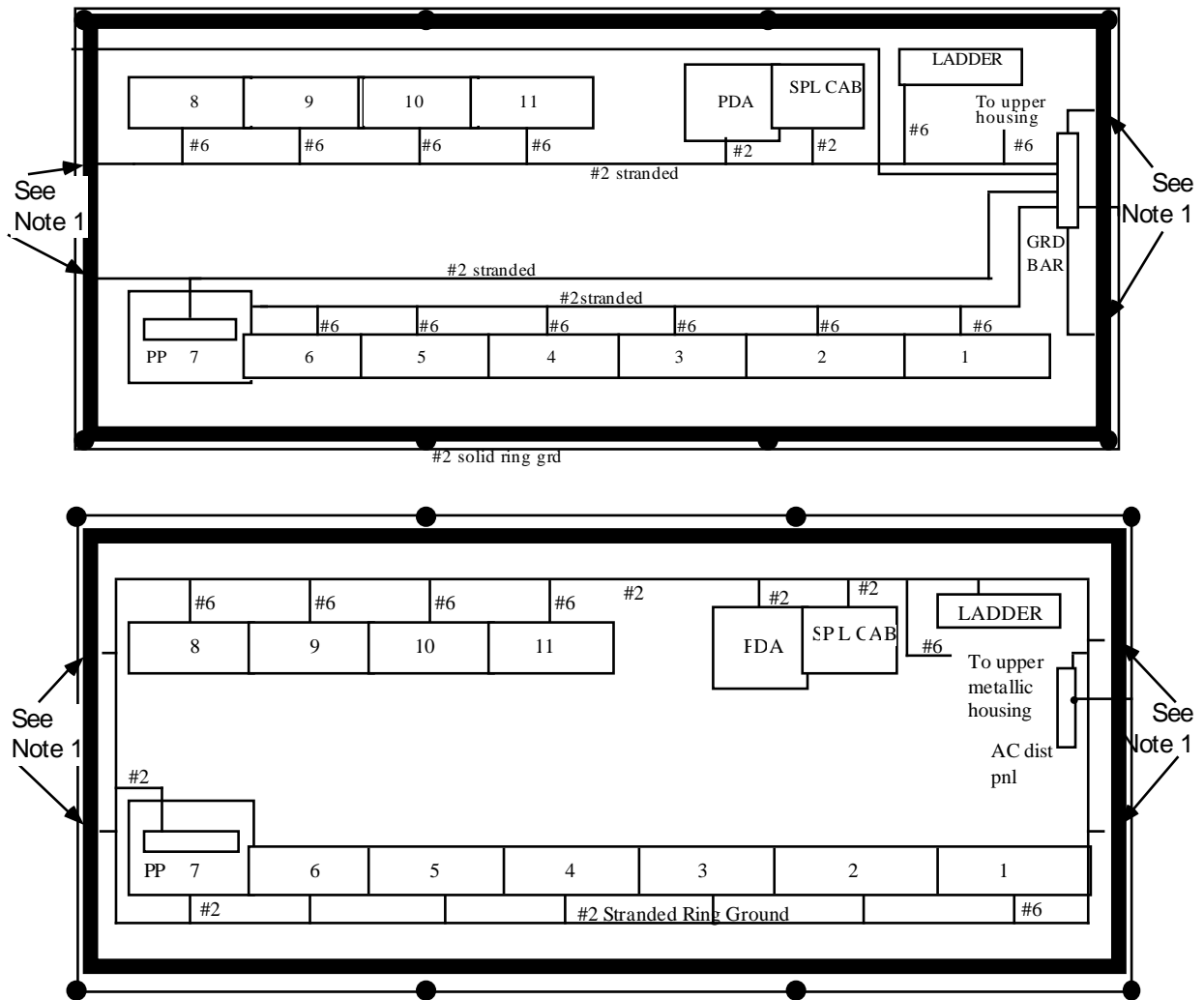

Figure 10-3: Typical CEV Bonding of Upper and Lower Housings



Note 1: Ground Entrance Coupling Provided by Vault Manufacturer

Figure 10-4: Typical Grounding Arrangement for CEVs



Note 1: Connect to upper housing ground plate.

Figure 10-5: Typical Inside Grounding for CEVs

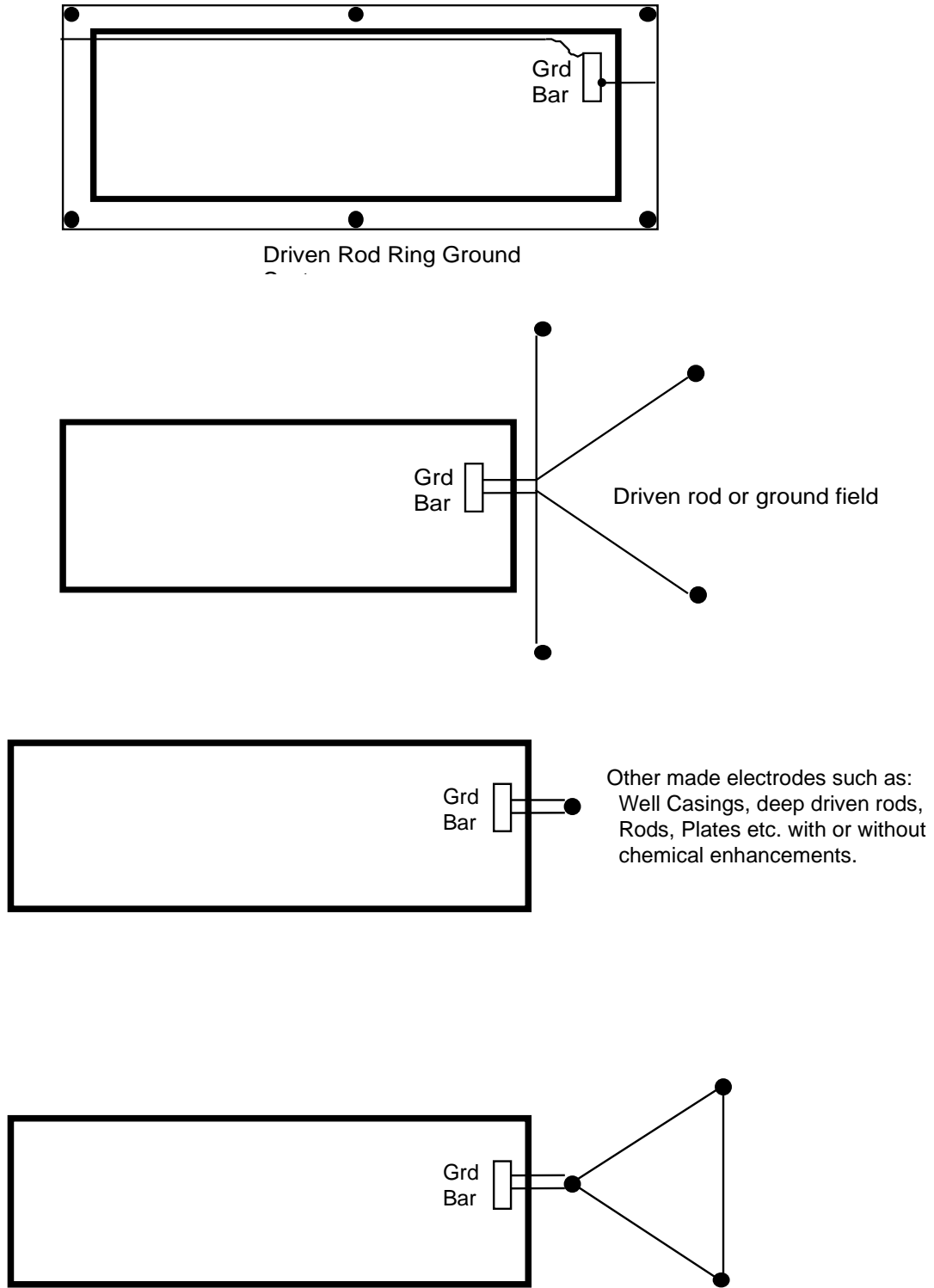

Figure 10-6: Examples of Grounding Schemes for Existing CEVs

10.2 Other Controlled Environment OSP Enclosures (huts, CECs, UEs, etc.)

A CEC™ or UE™ is similar to a CEV except it is not fully buried in the ground. The grounding requirements of a CEC or UE are very similar to those of a CEV and are mostly covered in Section 10.1. The main differences are that a CEC comes in one piece (although a UE is still in two pieces), so there is no need for bonding of upper and lower halves in a CEC; and typically the grounding leads to connect the inner and outer ground rings go through the above-ground cable entrance.

Aboveground huts (including NNS ROW sites) are often similar in size and structure to CEVs, CECs, UEs, and Radio sites. Grounding requirements from Section 10.1 or 7.21 may be used. Small portable buildings are often used as huts. A building raised above the ground on some kind of skid structure may not be at the same potential as earth. For these reasons, care should be taken in huts to bond and ground all metallic components (including metal skids, metal doorframes, metallic entrance conduits, etc.). In rare cases, a hut may contain Class 5 switching. In those cases, follow the guidelines of Chapters 8 and 9 for isolated ground planes.

10.3 Above Ground Outdoor Type Cabinets/Housings

Above ground outdoor type cabinets shall be properly grounded for safety and equipment protection. A ground electrode shall be engineered and installed in accordance with Chapters 3 and 4, and Section 10.1.

Install a driven ground system to establish a ground electrode for the cabinet. As in 10.1, the ideal is a ground field that measures 5 ohms or less of impedance to earth (less ideal is the 25 ohms specified in the NEC). The contractor should measure the resistance to earth after electrode installation with a 3-point tester. Typically, 4 ground rods should be installed for most electronic equipment enclosures (however, if less than 5 ohms are achieved with fewer rods, no more need to be added). Exothermically weld (or use an approved Listed irreversible compression crimp) the ground rods to a #2 solid copper conductor in a ring configuration. The 5/8" dia. x 8' (or 10') ground rods shall spaced 10-20' (in some cases, due to right of way limits, it may not be possible to achieve 10' spacing; in these cases, space the rods as far apart as possible). The ring shall be placed at least 2" (preferably 18-48") outside of any concrete pad on which the cabinet(s) sit, and at least 30" deep. Oftentimes, more than one electronics cabinet may be placed on a single pad. In these cases, the same ground field should be used for both cabinets. Two #2 solid copper conductors shall be routed into the cabinet and connected at the SPGP. The two #2 solid conductors shall be exothermically welded, or crimped with an approved tool and die designed for solid connections to a two hole copper connector and attached to the cabinet ground bar. All contact surfaces shall be cleaned to a bright metal finish and a non-oxidizing agent applied. (Figure 10-7 provides an example of DLC cabinet grounding, but note that it represents the dimensions of only one type of cabinet.)

In cold areas, consideration may need to be given to 10 foot ground rods instead of 8 foot rods. The 10 foot rod will ensure penetration below the frostline.

If a cabinet or repeater case is placed within a quarter mile of an electrical substation or high voltage AC transmission lines, contact the CenturyLink Electrical Protection Engineer for special considerations concerning ground potential rise, high voltage protection, and grounding electrode fields.

If the cabinet has a power plant, the battery return bar (usually the positive bar) shall be ground referenced to the cabinet ground bar with a #2 stranded insulated copper conductor. All equipment units within the cabinet shall be grounded either through direct contact with the grounded cabinet or with a #6 stranded copper conductor.

Cable sheaths, equipment units and battery plant framework shall be grounded as required with a minimum #6 stranded copper conductor to the cabinet ground bar.

The ACEG bar within the AC distribution panel should be grounded to the cabinet ground bar as shown in Figure 10-9. Cabinet metal may also be used to meet this bonding requirement as long as a resistance of less than 100 milliOhms can be shown between the ACEG and the cabinet ground bar.

Any metallic objects (fences, metal posts, cable TV boxes, telephone cable closures, etc.) that have a ground potential and are located within 6 feet (it is desirable to bond anything within 10 feet) of the cabinet shall be bonded to the outside driven ground system per NESC Article 384C.

All connections on conductor to conductor shall be done with copper crimp type connectors (C or H taps). All connections to any metalwork shall be done with two hole copper crimp type connections. All contact surfaces shall be cleaned so that a bright metal to metal contact is made. All connections must be treated with a non-oxidizing compound to prevent corrosion.

Small RTs, DSLAMs and ONUs (Optical Network Units) serving 96 or fewer customers are sometimes used (collectively they all fit in the category of remote electronics [RE]). Sometimes they are powered like a traditional RT, with local power, and a power pedestal. In those cases, a ring ground (as described in the preceding paragraphs) and less than 25 ohm resistance to earth are strongly preferred. In the case of line-powered or twisted pair remote-powered ONUs/RTs follow the manufacturer's grounding guidelines (in the case of some small ONUs/RTs, this may mean only two rods are required as the minimum), or drive a minimum of 3 rods (preferably 4) in a straight line in the cable right-of-way, separated by at least 10 feet and connected together (see Figure 7-24 for an example of this 3-rod configuration). Square and triangle configurations of the rods are also acceptable if they will fit in the right-of-way and allow proper spacing of the rods. If the power company's MGN is nearby, bond to it. Note that in some locations where the project is funded through RUS funding, it may be necessary per RUS standard units to install exactly 4 rods.

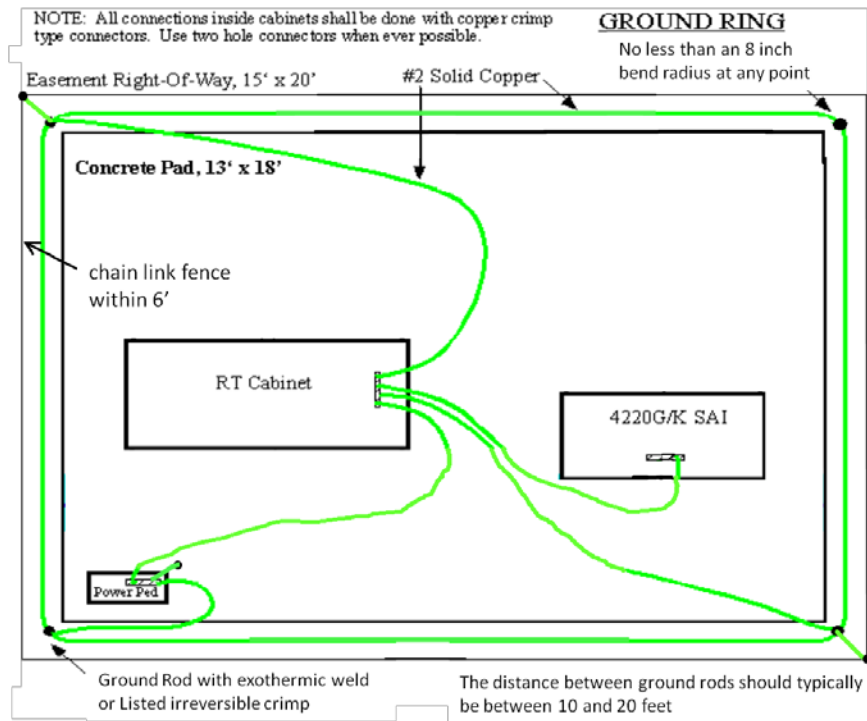

Figure 10-7: Typical RT Site where Most Structures are Bonded to a Common Bar

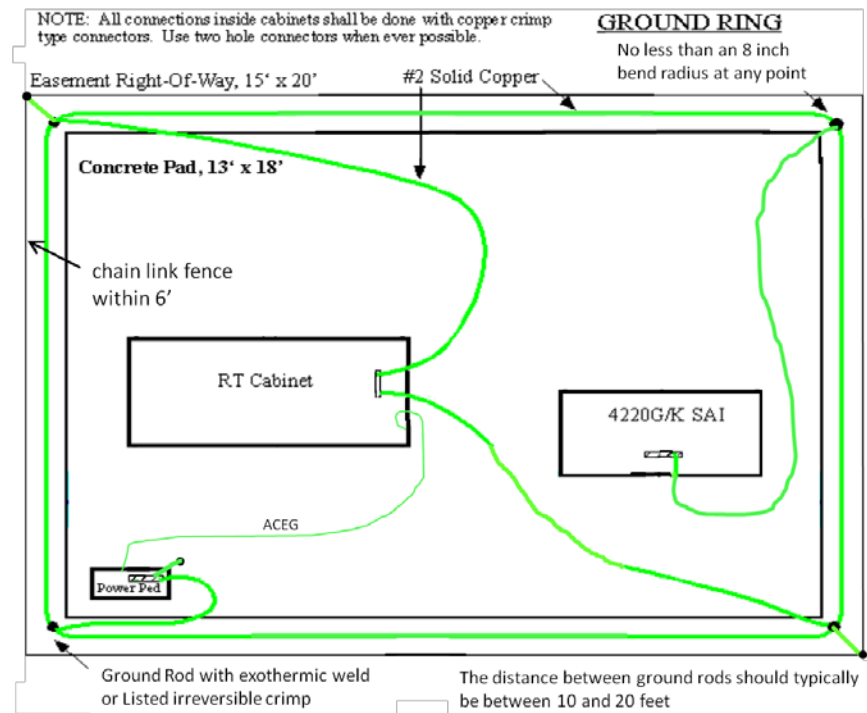

Figure 10-8: RT Site Structures Grounded to Ring when SAI Sheathes Isolated

Oftentimes, repeater cases are placed in manholes. These manholes are typically concrete vaults that are Ufer-grounded. Connected to the rebar of the concrete are bonding ribbons or conductors. The repeater cases, and any associated protectors should be bonded to these ribbons or conductors. Above-ground (whether pole- or pad-mounted) repeaters should be bonded to an accessible MGN. If no MGN is accessible, or if the MGN is proving to be inadequate, 2-4 appropriately-spaced rods should be driven and connected (see Figures 7-24 and 10-6 for examples of 3-rod systems).

For all RTs, ONUs, and repeater cases where we drive ground rods, ensure that the cable sheaths and protectors are grounded (in the case of integral pair protectors, it may not be necessary to make an external connection, since most of them have the protector backplane connected to a metal bar which then connects to the ground lug).

Oftentimes, there is more than one RT cabinet on a pad or at a given site. Only one ring ground is required (with all cabinet ground bars bonded to it) for cabinets located within 45 feet of each other. However, if there are multiple rings for cabinets within 60 feet of each other, they should be tied together (reference Figures 7-1 and 7-2).

SAI (Serving Area Interface, commonly known as Cross-Connect or XC or cross-box) cabinets at RT sites are not always required to be grounded (the cable sheaths in them are supposed to be grounded at other places too, but since there is easy access to a ground ring and the power company's MGN, it is advisable to bond these cabinets to the ring too). In traditional rural independent telco locations for RT cabinets served from PANI Central Offices, similar to the CO CEF in a PANI office, there usually is no bonding across the shield in the SAI (the OSP F2 cable shields are bonded to the SAI ground bar, but the shields of the F1 cables going back towards the collocated RT cabinet are not bonded in the SAI – they are only bonded in the splice chamber of the RT). This is often described as an isolated entrance (per ANSI/ ATIS 0600313.2008) similar to what is described in section 6.3; and in some older cabinets occurs in the RT splice chamber rather than in the SAI (isolation in the SAI is preferred in all new RTs). In these cases, it is often useful to tie the SAI grounds directly to the ring, as depicted in Figure 10-8. Also in these cases, the shields of the cables going towards the RT should not contain any bonding hardware (such as bullet bonds), and it may be useful to insulate the shield on that side with tape to prevent arcing. The cables should have a label affixed to denote whether and where the shield is isolated.

10.4 Grounding of the AC Neutral

In almost all cases (the only exception might be an extreme separation in distance between the power ped and the served equipment enclosures), per NEC rules, the power pedestal and electronic equipment enclosures are treated as a common structure for purposes of MGN to ACEG bonding. Figure 10-9 shows this configuration.

When portable generators are connected to the power pedestal, they must be wired as shown at the end of Chapter 7 of CenturyLink Tech Pub 77385, and in such cases are usually not considered a separately-derived source (due to the solidly-bonded neutral). The generator also should be located within 25 feet of the power pedestal.

The power utility company (or the electrician contracted to install AC service to the site) will usually drive their own ground rod (or two, separated by at least 6 feet) right near the AC service entrance per local and national Code and practice. This rod is shown in Figure 10-9, and while often connected to the neutral bus of the power pedestal with a solid tinned #2 AWG, per NEC Article 250.66, it can be as small as #6 AWG if the service entrance conductors from the utility into the power pedestal are 1/0 AWG or smaller.

Due to right-of-way, roads, etc., it is not always possible to place a power pedestal next to the RT(s) it is serving. Although a power pedestal can theoretically be placed up to 1000 feet from the RT(s) it is serving, it is typically not economical to place the RT more than 150 feet from its power pedestal. A new location or an expanded ROW for the RT should be considered if this maximum 150 foot distance is exceeded. The distance rules for the power pedestal from the transformer are the same.

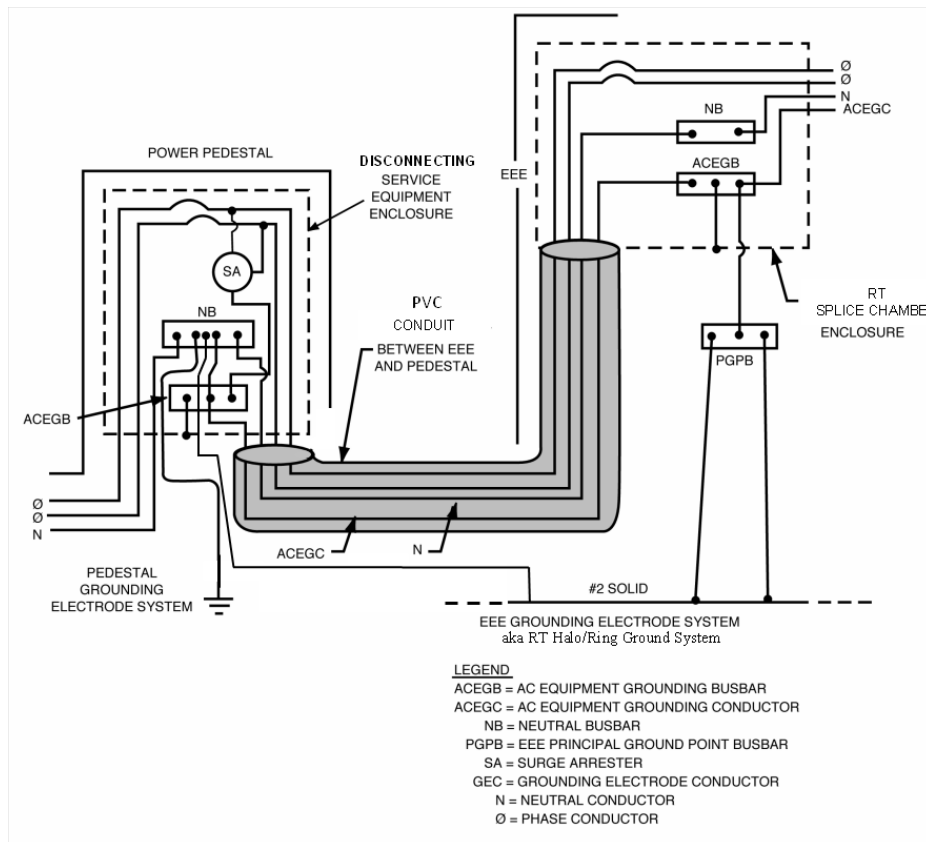

Figure 10-9: Power Pedestal and RT Treated as one Structure

10.5 Customer Premises Electronic Equipment Installation Grounding

Customer Premises grounding for CenturyLink is covered in detail in CenturyLink Technical Publication 77368, Chapter 6 and Section 7.8. Excerpts are provided in the following paragraphs.

There are essentially three types of Customer Premises installations from a grounding perspective, those that are relay-rack mounted (which are typically larger), those mounted in one or more Customer Premises lockable cabinets (this is now the most common type of Customer Premises installation), and smaller wall-mount installations.

Because the customer owns the property in these types of installations, it is not always possible for CenturyLink to mandate the placement of a good driven ground system. For this reason, the following ground electrodes are also acceptable for Customer Premises installations. They are listed in priority order.

- A Driven Ground System, as described in Section 3.2.
- Cold Water Pipe, as described in Section 3.2.7. It must be ensured that this piping is completely metallic (bond around plastic/PVC, water meters, and other non-metallic sections) all the way into the earth. (Checking with the city can also ensure that it is metallic for a considerable distance from the building.)
- Building Steel, as described in Section 3.2.7.
- The ACEG, if properly bonded to the power company's MGN at the HSP can serve as a ground source. If it is used as the ground source, the connection should be made as closely as possible to the HSP or nearest separately derived source.
- Absence of any of the above sources requires use of the AC Neutral. As with the ACEG, a connection to this ground source should be made as closely as possible to the HSP or nearest separately derived source. (Because this method holds the potential for rebonding the neutral to the cable sheath, it should only be used as a last source of ground reference when no other can be found.)

If there is a driven ground system, it can be the only ground electrode source. If it can't be used, try to obtain at least two of the other sources listed above to connect to our CenturyLink TMGB (Telecommunications Master Ground Bar). It is preferable that the ground electrode field have an impedance to earth of less than 5 ohms, but if that is not possible, the impedance should not exceed the 25 ohm maximum specified in the NEC.

CenturyLink requests that the customer extend the selected ground source(s) to the "telecommunications equipment room" with a cable sized according to the NEC (a minimum of #6 AWG) and terminate it on a ground bar that they provide (SPGP). Typically, CenturyLink will collect all of its grounds to a single collection point, and then cable that single collection point to the TMGB with a #2 AWG minimum (a #6 AWG minimum is minimally acceptable for Customer Premises cabinets). Failing the presence of a customer-provided SPGP or TMGB bar, CenturyLink should cable its single collection point to one or more of the ground sources listed above.

If a copper entrance facility is used, the Building Entrance Terminal should be located as closely as possible to the HSP (preferably within 20 feet according to the NEC) and grounded to one of the electrodes mentioned previously (the same electrode as that used for the SPGP). If a fiber only entrance is used, and the fiber cable does not have metallic members, this requirement is not necessary. (Grounding and bonding of metallic cables that enter buildings is covered in NEC Article 800).

CenturyLink's "ground collection bar" can be a separate ground bar, the customer-provided SPGP, or the battery return bus of the power plant. If the power plant return bus bar is large enough to accommodate extra grounding connections, the use of an extra ground collection bar can be avoided. However, some Customer Premises installations are too large, and some power plant return bus bars too small to use the return bus as the ground collection bar. In this case, either the customer-provided SPGP (if large enough) can be used, or a separate ground collection bar can be installed. Regardless of which bar is used as the ground collection bar, the following grounds should be connected to this "telecommunications equipment ground collection point":

- The Power Plant Return Bus Bar, unless used as the "collection bar" should be connected to the ground collection bus with a minimum #6 AWG conductor (use a minimum #2 AWG if the installation is a larger relay-rack type of installation). For plants smaller than 15 Amps, the reference conductor can be as small as #10 AWG.
- Equipment Cabinet rails, walls, and doors shall be electrically bonded; and then a connection shall be made from each cabinet to the ground collection point directly with a #6 AWG, or indirectly to a #2 AWG stringer run from the collection bar.
- Equipment Relay Racks should be connected to the collection point. If there are multiple relay racks and/or lineups, it may be wise to run a #2 AWG stringer above each lineup. A splice with a #6 AWG can be made to each relay rack frame from this stringer.)
- Shields of cables entering the space from the OSP should be bonded to a Splice Case ground point, which is in turn connected to the collection point with a #6 AWG. If there are metallic cables entering the space that do not feed CenturyLink digital equipment, their sheath grounds should be tied to the customer's ground bar, as opposed to the CenturyLink single-point collection bar.

If the entrance is copper cable, each metallic pair in the cable must be protected, using a listed protector unit. The ground for the protector frame(s) should also be connected to the collection point, if they are in the same room. The NEC requires that the protector ground be bonded back to the building grounding electrode, so care must be exercised in equipment placement.

- The ACEG of the feeds to the Rectifiers should be extended to the collection point by use of a bonding jumper sized per the NEC. (This is not necessary if the ACEG or AC Neutral is serving as the ground source.)

- The ACEGs of any Appliance/Convenience Outlets in the telecommunications equipment space may be **optionally** bonded to the collection point. (As above, this is not necessary if the ACEG or AC Neutral is the ground source.)
- Any Other Metallic Bays, Cabinets, or Other Metal Objects in the telecommunications equipment area may be bonded directly to the collection point with #6 AWG, or connected to the collection point through “stringers” as described above. This is especially helpful in reducing ESD problems for cabinets that are used as storage for circuit packs.

Bonding metallic components of non-CenturyLink equipment located within 6 feet of CenturyLink equipment needs to be brought to the attention of the Customer Premises' controlling authority (landlord and/or owner). Un-bonded metallic frames may present a shock hazard to any person in the area. The Customer Premises' controlling authority should be made aware of any such situations and asked to encourage all providers to bond their equipment to a customer-provided ground bar (see an earlier paragraph in this section).

10.5.1 Special Protection Requirements for Customer Premises Locations On or Near High Voltage Electric Power

Special electrical high voltage protection (sometimes requiring added grounding) is required for communications facilities located on or near electric power generating stations or electric substations, or transmission lines. Guidelines are outlined in CenturyLink Tech Pub 77321, ANSI/IEEE Std. 487-1992, and Telcordia BR 876-310-100. These documents describe under what circumstances the protection is necessary, and how to apply the protection (including grounding application).

See section 7.23 for further guidance on wireless backhaul cabinet/enclosure grounding. If CenturyLink is collocating their backhaul equipment in a wireless carrier's cabinet, see Tech Pub 77419 for guidelines and requirements.

10.5.2 Customer Premises Computer Room

Sometimes the space the customer gives CenturyLink to place telecommunications equipment is in a computer room. There are two basic types of computer room grounding schemes: single-point, SRG, "isolated"; and multi-point ground systems. Multi-point ground systems are similar to regular CenturyLink integrated ground planes as described in Chapters 3 and 5, and Section 10.5 of this document; so those rules apply. For computer rooms with a single-point SRG grounding system, the customer may require that CenturyLink equipment receive a "special" ground. Guidelines in Chapter 11 should be followed in these cases.

E-911 PSAP locations where the local governmental agency owns the 911 equipment, but it is maintained by CenturyLink are not covered by this document or by Tech Pub 77368. For these types of sites, see Tech Pub 77339.

10.5.3 Customer Premises Isolated Ground Planes

Sometimes the space the customer gives CenturyLink to place telecommunications equipment has a PBX. Sometimes, the PBX manufacturer requires an isolated ground plane. Normally, this does not affect the CenturyLink integrated ground plane equipment. However, if located within 6 feet of the isolated ground plane, CenturyLink equipment may be FOG bonded. Whether the Customer performs this FOG bonding, or CenturyLink does is open to negotiation.

In the case of some local governmental 911 facilities, the customer may purchase an OEM PBX from CenturyLink. Depending on the recommendations of the PBX manufacturer, an isolated ground plane may be required or desired. Some PBXs are DC-powered. In those cases, the guidelines of Chapters 8 and 9 should be followed in setting up an isolated ground plane where the PBX manufacturer requires it. For AC-powered PBXs, the equipment manufacturer grounding recommendations are the rules. Typically, when an isolated ground-plane is required for an AC-powered PBX, the equipment manufacturer recommends the use of the ACEG bus (in the AC panel feeding the switch) as the MGB.

CONTENTS

Chapter and Section	Page
11. Computer Room Ground Environment	11-1
11.1 Purpose	11-1
11.2 Scope	11-1
11.3 Grounding Concepts	11-1
11.4 Optimal Ground Point	11-2
11.5 Signal Reference Grid (SRG)	11-2
11.6 Cabinet Grounding System	11-3
11.7 Other SRG Connections	11-4
11.8 ACEG “Green-Wire Ground”	11-4
11.9 Raised Floor Surface	11-5

Figures

11-1 Typical Computer Room Grounding Arrangement	11-6
11-2 Bolted Stringer Raised Floor to Pedestal Connection.....	11-7
11-3 Supplemental Signal Reference Grid	11-8
11-4 Typical Cabinet Grounding Arrangement.....	11-9
11-5 Computer Cabinet Grounding Bar	11-10
11-6 Attaching Braided Strap to a Round Raised Floor Support Pedestal.....	11-11

11. Computer Room Ground Environment

11.1 Purpose

This section recommends a multi-point grounding method for computer installations. It is not intended to replace or modify the grounding requirements of the NEC and/or other applicable codes. These codes provide for safety grounding, but do not provide the low noise ground system required by interconnected cabinets of sensitive electronic equipment. The protection afforded by the multi-point grounding system described herein should equal or exceed present requirements of various equipment suppliers. This section establishes a standard requirement that:

- Will allow sensitive electronic systems to be compatibly installed into a common ground plane and be served by a common power supply.
- Shall be used as a specification for a grounding system.

11.2 Scope

In this section, only raised floor installations of computer equipment are considered in detail.

11.3 Grounding Concepts

There are two fundamental grounding concepts in use, the single point ground system and multi-point ground system.

In the single point ground system, components are effectively bonded together to create a common signal reference ground plane. This ground plane is insulated from incidental or deliberate connections with any other ground system, except for a single connection at a 'ground window'. The 'ground window' establishes a point of voltage neutrality between the signal reference ground plane and all other ground systems. The signal reference ground plane cannot be affected by current surges originating outside the plane because at least two connections are required for current to flow through the plane.

Although a single point ground system is recommended for a Stored Program Control Switching system environment, in a general purpose computer room environment it is difficult to prevent foreign ground contacts. For this reason the single point ground system is not recommended by the IEEE Recommended Practice for Powering and Grounding Sensitive Electronic Equipment (Emerald Book).

In a multi-point ground system, as in the single point ground system, all components are effectively bonded together to create a common signal reference ground plane (Fig. 11-1). However, connection to other ground systems by this ground plane is not limited to a 'ground window', and requires that all conducting paths entering (and/or within 6' of) the ground plane must be bonded to a signal reference ground plane herein referred to as the Signal Reference Grid (SRG).

11.4 Optimal Ground Point

The optimal connection point to ground for obtaining a stable ground reference should be equivalent to the CO Ground System. If the computer facility is not equipped with a CO Ground System, then one shall be provided.

If the CO Ground is not located in the computer room space, an extension of the CO Ground should be provided. This ground should consist of a copper ground bar, installed within the computer space, insulated from its support and fed from the CO Ground by a 750 kcmil, insulated, copper ground wire. Two hole, crimp type lugs should be used for all connections.

11.5 Signal Reference Grid (SRG)

The SRG system shall form a ground reference point for the raised floor computer equipment. This ground will provide a low impedance path to high frequency disturbances and a capacitive coupling with the data cable shield to reduce high frequency noise.

The SRG shall be connected to the CO Ground with a #2 AWG, copper, stranded, insulated wire using two hole compression lugs at the CO ground. The method of connection to the SRG shall be dependent on the type of SRG installed.

As a minimum, the SRG shall consist of a bolted stringer raised floor support structure. The bolted stringer to the pedestal head connection of this structure shall be installed and maintained with a resistance of less than .5 milliohms.

The integrity of the bolted stringer SRG is dependent on maintaining a low resistance stringer to pedestal head connection. Since proper maintenance of this connection cannot be guaranteed, it is recommended that a supplemental SRG be installed with the bolted stringer raised floor. This supplemental SRG can take the form of a continuous sheet metal element installed prior to the installation of the raised floor support pedestals (for new construction only) or a grid of bare copper wires installed under the raised floor as described below for non-bolted stringer applications.

In existing facilities where a non-bolted stringer floor is installed, a supplemental SRG must be installed. This supplemental SRG shall be composed of multiple runs of bare, stranded #2 AWG copper wire routed along each row of the raised floor pedestals in both directions under the raised floor, thus forming a grid. Bond each wire run at the intersecting point of each perpendicular wire run and the raised floor support pedestal (Fig. 11-3) by a mechanical connector that shall also tie the grid to the pedestal.

Prior to installation of the SRG connector, ensure that the surfaces of all raised floor pedestals are properly prepared. Remove all grease, dirt, surface coatings (i.e. paint), and rough projections. Torque and/or compress all SRG fittings to manufacturer's specifications.

If the floor support pedestal leveling adjustment is at the top of the pedestal, then a #6 AWG flat braid strap must be installed between the pedestal leg and one of the four adjacent stringers. Connection to the stringer shall be on the bottom using a two hole, crimp lug and two (2) #10 self tapping screws. The type of pedestal leg (round or square) will determine the method for that end of the connection as follows:

- Connection to round pedestals shall be made by clamping the #6 AWG flat braid to the leg with a screw type, stainless steel hose clamp (Fig. 11-2A).
- Connection to a square pedestal shall be made with a two hole, crimp lug and two (2) #10 self tapping screws (Fig. 11-2B).

11.6 Cabinet Grounding System

Individual system cabinets (i.e. processor cabinets, expansion cabinets, peripherals, communications cabinets, power distribution units, transformers and floor mounted air handling equipment) shall be grounded to the raised floor grid.

Note: Some manufacturers' specifications do not require this connection. This equipment may be excluded from the grounding requirement after careful review and consideration by a CenturyLink Facility Environmental Manager.

The connection between the cabinet and the SRG shall be made with a #6 AWG, flat braided copper strap and should be no longer than two feet. The braided SRG ground strap shall be attached with a two hole, crimp type lug to a flat surface near the bottom of the cabinet frame (Fig. 11-4), in a reasonably accessible location. This area shall be prepared to a bare, bright finish for connection of the ground strap by drilling and tapping two 1/4-20 holes and attaching the lug with two 1/4-20 x 3/4 inch bolts. An alternate method would be to drill two 5/16 inch holes and attach the lug with two 1/4-20 x 3/4 inch bolts, two 1/4-20 nuts and two internal tooth lockwashers (#10 self tapping screws may also be utilized if required). The internal equipment mounting bracket, which may be more readily available, can also be used to connect the ground lug.

Connection to the SRG must be provided by one of the following methods:

- Attaching a two hole, crimp type lug to the bottom of the raised floor stringer, utilizing two 1/4 inch self-tapping screws.
- Connection to a square raised floor support pedestal may be accomplished by one of two methods:
 - Drill two 1/4 inch holes through the pedestal (Fig. 11-4), attach a two hole, crimp type lug with two 1/4-20 x 1 1/2 inch long bolts, two 1/4 inch internal tooth lockwashers, and two 1/4-20 nuts. The bolts are sufficient in length to attach a lug on each side of the pedestal for grounding two computer cabinets at the same location.

- Using a fabricated stainless steel bar (Fig. 11-5 & 11-6) drilled to accommodate the above mentioned two hole lug and a 1/4 x 1 1/2 inch U - bolt (depending on the width of the pedestal). Attach the U-bolt and bar to the pedestal using two 1/4 inch internal tooth lockwashers and 1/4-20 nuts. Attach the two hole lug to the bar using two (2) 1/4-20 x 3/4 inch round head bolts, two (2) 1/4-20 nuts, and two (2) 1/4 inch internal tooth lockwashers. Two lugs may be attached at this point for two cabinet ground connections.
- Attaching to a round pedestal may be accomplished by the method above or by clamping the flat braid with a screw-type, stainless steel hose clamp.

Note: Torque all connections to 80 in-lbs. 1/4-20 Teflon lock nuts may be substituted for the ITLW and 1/4-20 nut. A compound that inhibits oxidation must be applied to all metallic contact surfaces.

Remove all drill tailings with a hepa-vacuum.

Desktop CRT terminals, small printers, and other peripheral units of less than cabinet size need not be connected to the framework grounding conductor if grounded through the ACEG green-wire of the AC system.

Tables, desks, filing cabinets, and similar nonelectrical objects in proximity to the computer will not usually require grounding. If Electrostatic Discharge (ESD) proves to be an operational problem, grounding to the SRG is permissible.

11.7 Other SRG Connections

In general, all metal equipment (mechanical, electrical, etc.) crossing the grid of the raised floor shall be properly bonded to the SRG at the point of crossing or penetration. Metal equipment within 6 feet but not crossing shall be bonded at the point of closest proximity. Equipment separated from the SRG by a wall may be excluded.

Single or multiple electrical conduits or mechanical piping shall be attached to a metal channel with appropriate channel pipe straps. A #6 AWG flat braided strap with compression connectors shall attach the channel to the nearest raised floor pedestal as described in paragraph 11.6.

An alternate bonding method for individual electrical conduits or mechanical piping shall be a suitable pipe clamp and a #6 AWG flat braid with compression connectors at both ends attached to the nearest raised floor pedestal.

11.8 ACEG "Green-Wire Ground"

Each computer cabinet and peripheral cabinet shall be connected to an AC source by an electrical cord equipped with an equipment ground green-wire conductor (referred to in CenturyLink as ACEG). The supplier's specifications may include additional grounding requirements (i.e. Isolated Ground receptacles).

The use of Isolated Ground (IG) receptacles is not recommended by CenturyLink. However, they may be installed if it is found that their use will solve a specific noise problem or if the organization that is responsible for the maintenance of the computer equipment requires them. IG receptacles do not provide a ground path to the receptacle box through the ACEG green-wire ground pin of the receptacle and must be installed with an additional ground wire connecting the receptacle box to the source ground bus per the NEC. (If IG outlets are used, they should be connected to the "source ground bus" wire with a pigtail so that if one receptacle is removed it does not interrupt the "isolated" ground system.

11.9 Raised Floor Surface

Laminated floor tiles should be used in computer rooms. Carpeted floor tiles should not be utilized due to the possibility of Electrostatic Discharge (ESD).

To provide an adequate static electricity drain path and maintain personal safety, the resistance from the top of the floor tile to the SRG should be greater than 0.5 megohms but less than 20,000 megohms.

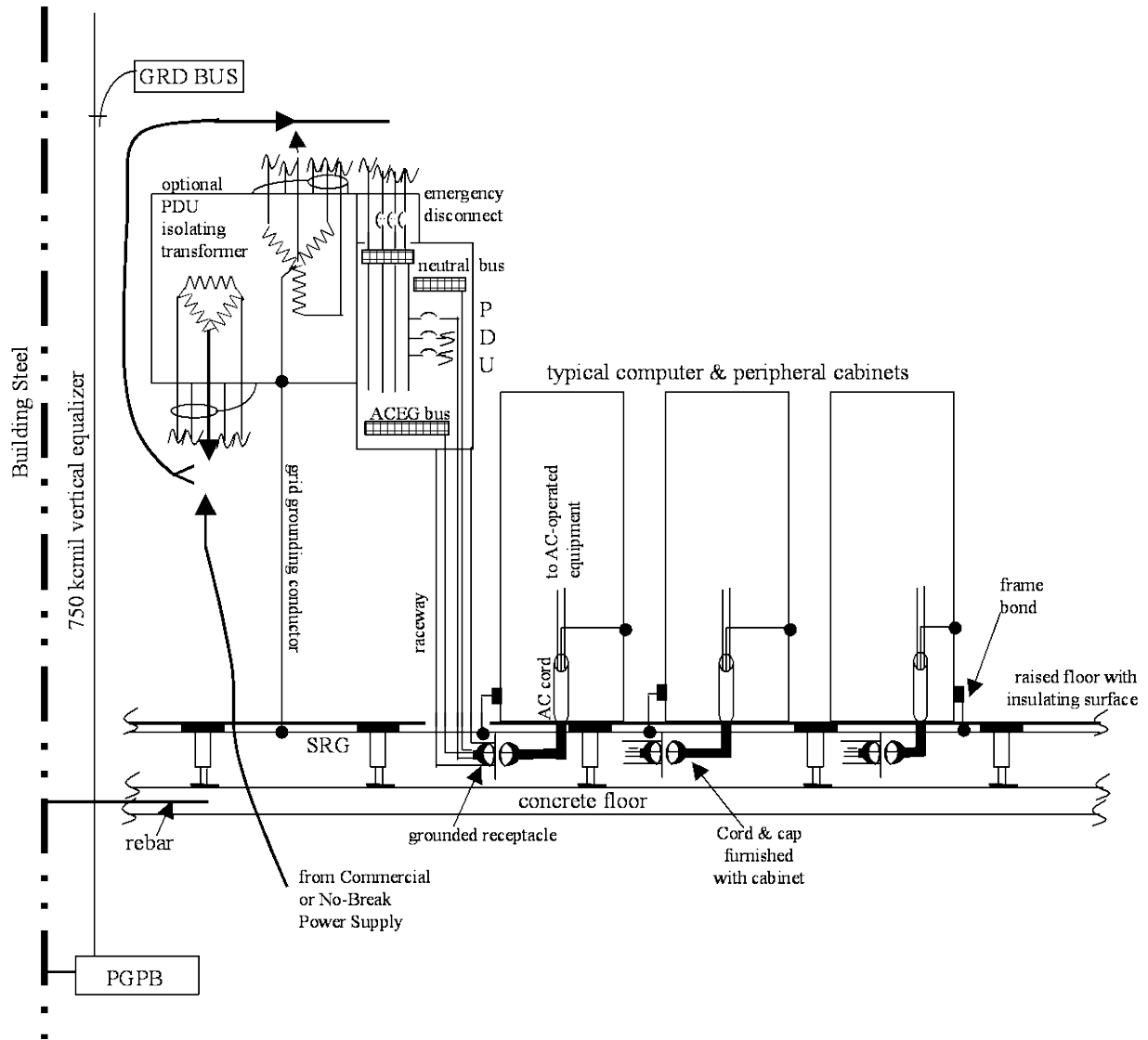

Figure 11-1: Typical Computer Room Grounding Arrangement

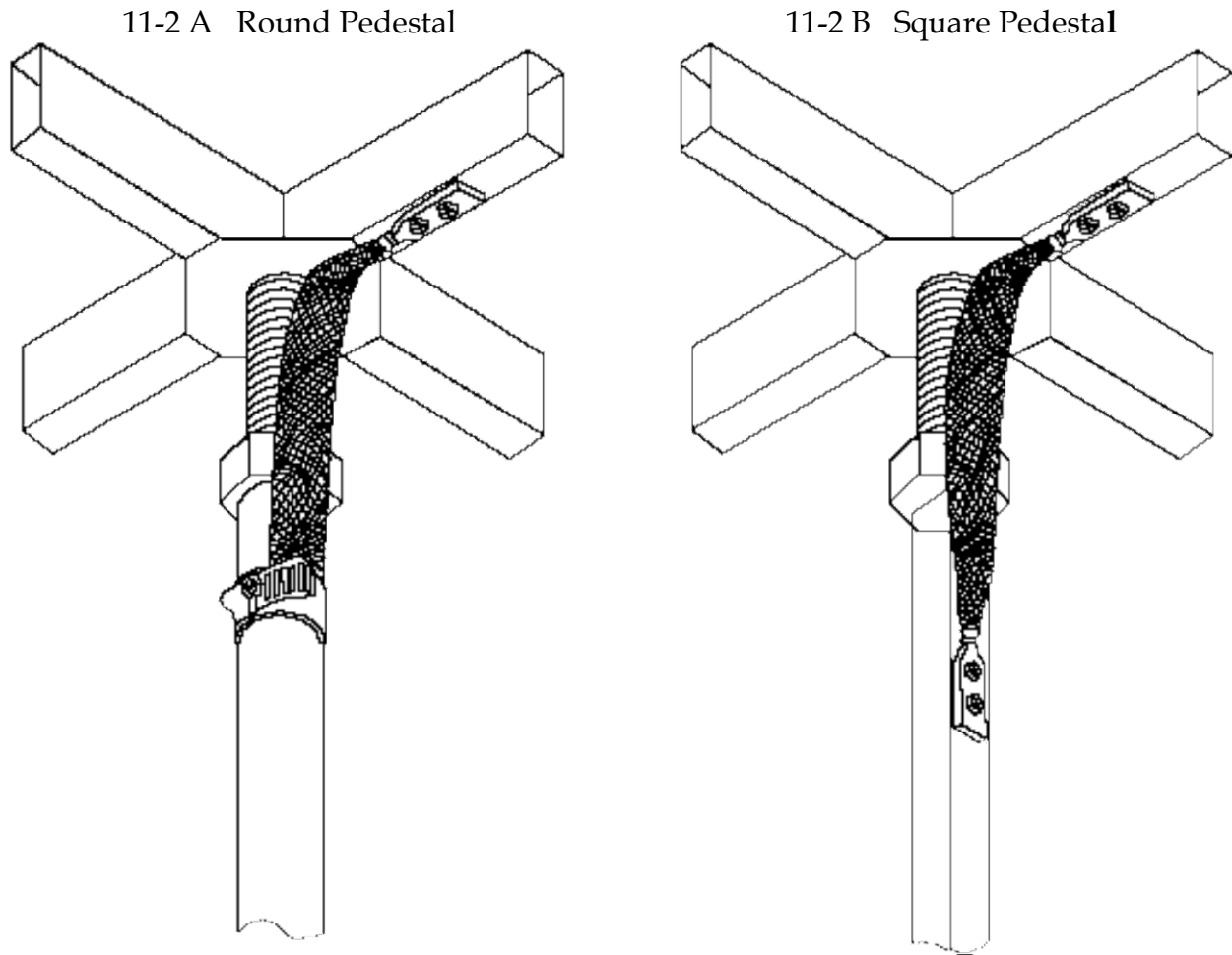

Figure 11-2: Bolted Stringer Raised Floor to Pedestal Connection

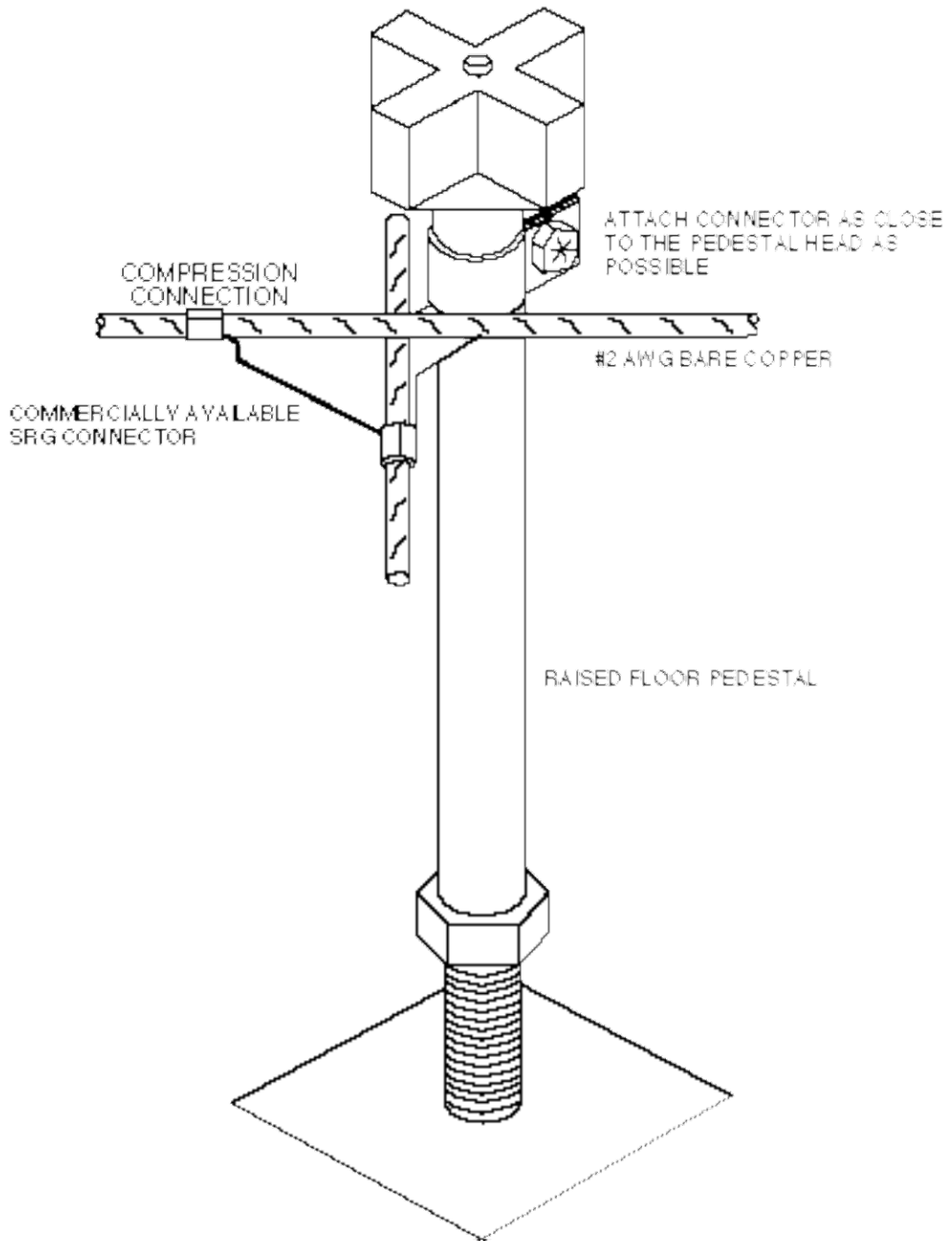

Figure 11-3: Supplemental Signal Reference Grid

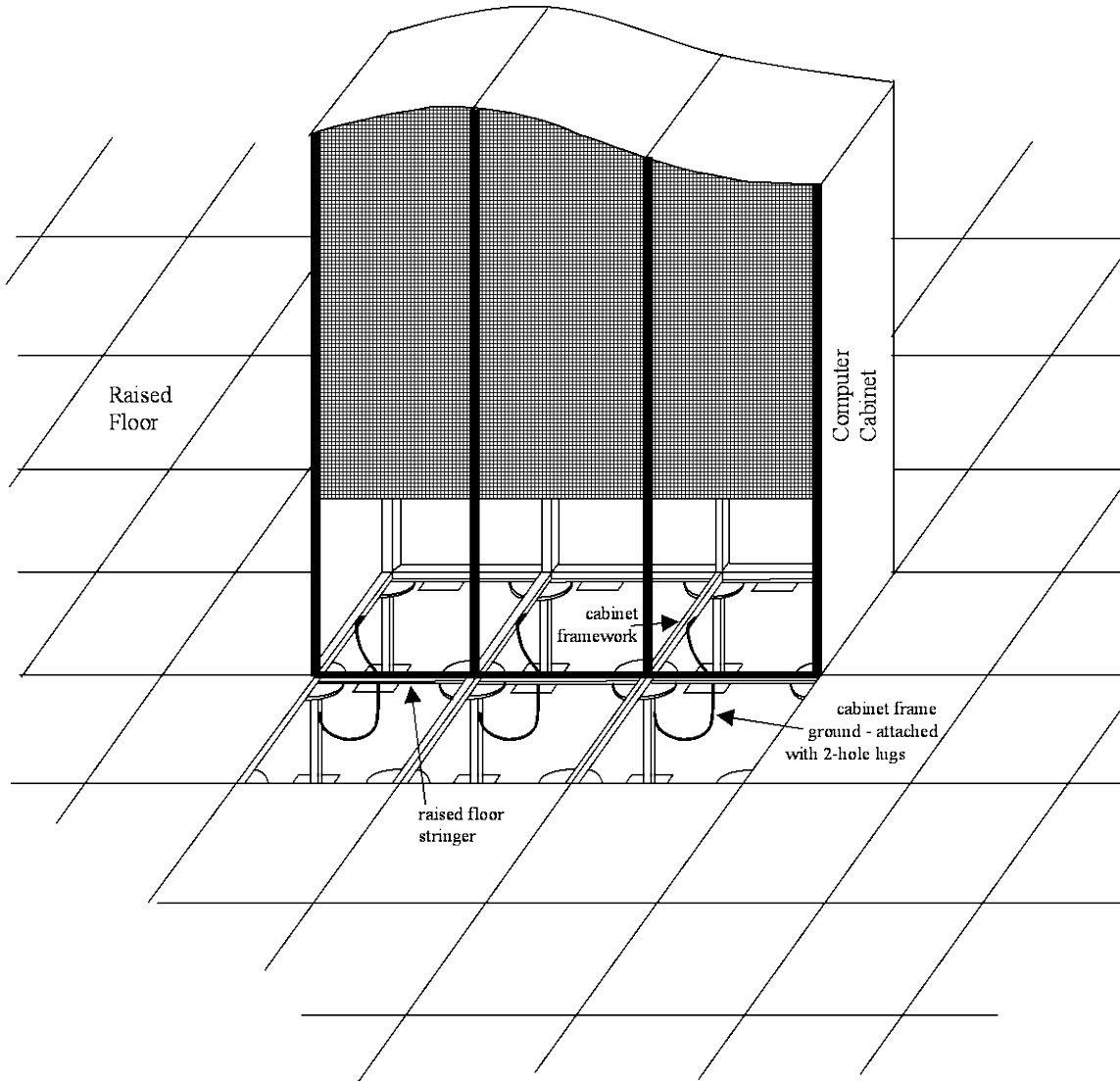

Figure 11-4: Typical Cabinet Grounding Arrangement

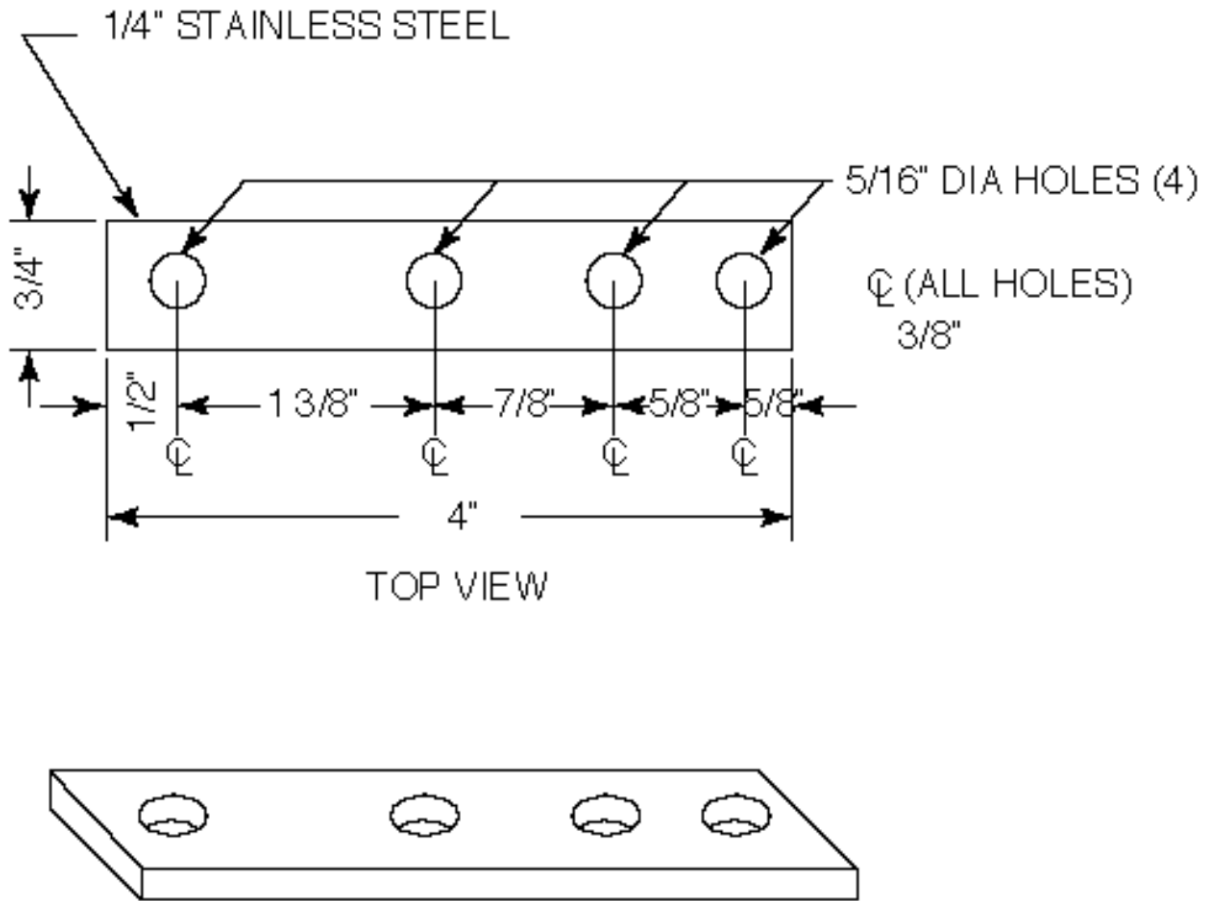
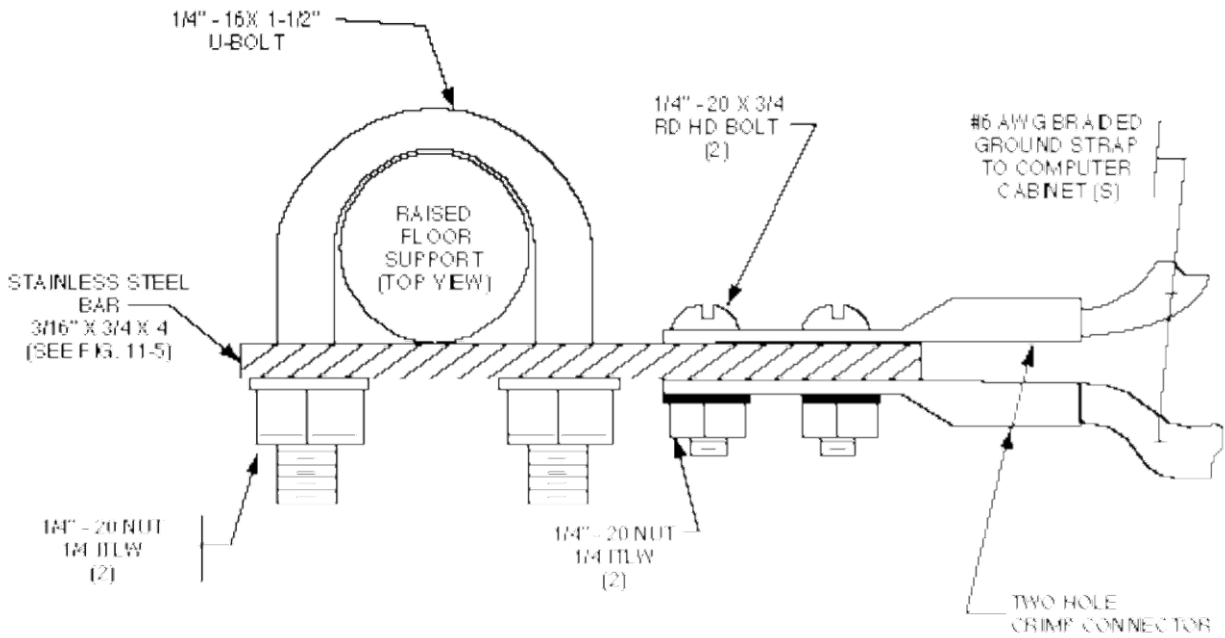

Figure 11-5: Computer Cabinet Grounding Bar



Notes:

1. A non -Oxidizing Agent Shall be used on all metallic connections.
2. This configuration can also be used for Square Pedestals

Figure 11-6: Attaching Braided Strap to a Round Raised Floor Support Pedestal

CONTENTS

Chapter and Section	Page
12. Definitions.....	12-1
12.1 Acronyms.....	12-1
12.2 Glossary.....	12-8

12. Definitions

12.1 Acronyms

A	Amperes (a measure of electrical current); or Absorbers
AC	Alternating Current; or Armored Cable
ACEG or AC EG	Alternating Current Equipment Ground (green-wire ground)
Ah	Ampere-hour (battery rating)
ANSI	American National Standards Institute
AWG	American Wire Gauge
10Base-T	10 Mbps ethernet Transmission
100Base-T	100 Mbps ethernet Transmission
Batt(s)	Battery (-ies)
BCT	Bonding Conductor for Telecommunications
BCW	Bare Copper Wire
BDB	Battery Distribution Board/Bay (Primary Power Plant distribution)
BDFB/BDCBB	Battery Distribution Fuse / Circuit Breaker Board/Bay
BET	Building Entrance Terminal (equivalent of a NID for a larger business)
BFR	Bona Fide Request (special request process for Collocators)
BICSI	Building Industry Consulting Services International
BR	Bellcore Requirements; or Battery Return
BRI	Business Resources Incorporated (old terminology for the Real Estate Services department within U S WEST)
BSP	Bell System Practice
BX	Armored Cable
Cat5	Category 5 twisted-pair ethernet cabling
Cat6	Category 6 twisted-pair ethernet cabling
CBN	Common Bonding Network (new term for integrated ground plane)
CDF	Combined Distribution Frame
CDO	Community Dial Office (small CO)
CEC	Controlled Environmental Cabinet (half-buried vault)
CEF	Cable Entrance Facility

CEGB	Cable Entrance Ground Bar/Bus
CEV	Controlled Environmental Vault
CLEC	Competitive Local Exchange Carrier (Collocator)
CLGB	Collocator's Local Ground Bar
CMGB	Collocator's Main Ground Bus
CO	Central Office
coax	coaxial cable
COE	Central Office Equipment
COGB	Central Office Ground Bus/Bar
COGF	Central Office Ground Field
config	configuration
CORM	Clamp-On Resistance Meter
CPE	Customer Premises Equipment
D-4	Digital Carrier System, 4 th generation
DA	Distribution Area (interface between F1 and F2 cable)
DC	Direct Current
DC-C	DC return Commonly bonded to the frame ground at the equipment (shared return)
DC-I	DC return Isolated from the frame ground (DCEG)
DCG	DC System Ground reference conductor
DCEG	DC Equipment Ground conductor
DISC*S	Digital Intelligent Subscriber Carrier System
DLC	Digital Loop Carrier
DLO	A flexible type of RHW power and grounding cable
DMM	Digital multimeter
DMS®	Digital Multiplex System (switching system made by Nortel)
DOD	U.S. Department of Defense
DS-1	Digital Signal Level 1 (1.544 Mbps data rate)
DS-3	Digital Signal Level 3 (44.736 Mbps data rate, with 28 DS-1s)
DSLAM	Digital Subscriber Line Access Multiplexer
DSX	Digital (system) Cross-Connect

E-911	Emergency 911
EEE	Electronic Equipment Enclosure
EIA	Electronic Industries Alliance
EMI	Electro-Magnetic Interference
EMT	Electrical Metallic Tubing
ENT	Electrical Non-metallic Tubing (flexible corrugated conduit)
ESD	Electrostatic Discharge
ESS	Electronic Switching System (see also SPCSS)
F1	Feeder copper cable (from electronics at CO/RT to SAI)
F2	Distribution copper cable (from SAI to homes/businesses)
FGB	DMS switch Frame Ground collection Bar; or Floor Ground Bar
FGE	Frame Ground Equalizer (equivalent to the DMS FGB)
FMC	Flexible Metal Conduit
FOG	Foreign Object Ground
FRWK	Framework
GB	Ground Bar/Bus
GE	Ground Equalizer
GEC	Ground Electrode Conductor
GigE	Gigabit ethernet
GND or GRD	Ground
GPDF	Global Power Distribution Frame (for 5 ESS™ switches)
GPR	Ground Potential Rise
GPS	Global Positioning System (used to provide sync/timing)
GR	Generic Requirements
GWB	Ground Window Bar/Bus
HDSL	Hi-bit rate Digital Subscriber Line (carries DS-1)
HSP	House Service Panel (Commercial AC Service Entrance)
HVAC	Heating, Ventilation, and Air-Conditioning
I	symbol representing current, in Amperes; or Isolated
IBN	Isolated Bonding Network (new term for isolated ground plane)

ICB	Integrated Collector Bar (DMS foreign object ground collector bar)
ICDF	InterConnection Distributing Frame (Collocator cross-connect bay[s] – see also SPOT)
IDF	Intermediate Distributing Frame
IEC	International Electro-Technical Commission
IEEE	Institute of Electrical and Electronics Engineers
IG	Isolated Ground (receptacles for some computer rooms)
IGB	Intermediate Ground Bar (a bar sometimes used in non-IGZ areas in PANI offices as a collection point for frame grounds)
IGP/IGZ	Isolated Ground Plane/Zone
IL	Information Letter
info	information
IOF	Inter-Office Facilities
ITU	International Telecommunications Union
J-box	electrical Junction box
kcmil	the new designation for MCM (1 circular mil is equal to the cross sectional area of a circle 1/1000 th of an inch in diameter)
kW	kiloWatts
LNS	Local Network Services of Qwest (former USWEST)
LPDC	Local Power Distribution Cabinet (for 5 ESS TM switches)
LPS	Lightning Protection System
LRE/G	Logic Reference Equalizer/Ground (DMS Collector bar)
max	maximum
Mbps	Megabits per second
MC	Metal-Clad cable
MCM	Thousand Circular Mils (old designation)
MDF	Main Distribution Frame
MET	Main Earthing Terminal
(T)MGB	Main Ground Bus (in the Ground Window); or the PANI bar (OPGP equivalent); the (Telecommunications) Master Ground Bar
MGE	Made Ground Electrode (typically a driven rod ring/field)
MGN	Multi-Grounded Neutral

MH-0	Man-Hole 0 (the first Manhole outside the CO)
MI	Mineral-Insulated metal-clad cable
mi	mile
MIL	Military (Specification)
min	minimum
MOV	Metal-Oxide Varistor (one type of TVSS device)
MPD	Main Power Distribution bay (Ericsson switch distribution bay)
N	Neutrals
NEBS	Network Equipment – Building System (a family of Telcordia documents governing physical safety, hazard, and electromagnetic compatibility of equipment)
NEC	National Electrical Code
NECA	National Electrical Contractors Association
NESC	National Electrical Safety Code
NFPA	National Fire Protection Association
NID	Network Interface Device (the terminal mounted on the side of a residence or small business that is the interface between the telephone company-owned equipment and the inside wiring owned by the subscriber – also known as a SNI)
NNS	National Network Services (CenturyLink long-haul network)
NRTL	National Recognized Testing Laboratory
OEM	Outside Equipment Manufacturer
OFC	Optical Fiber Cable
Ω	Omega (Ohms symbol, unit for Resistance/Impedance/ Reactance)
ONU	Optical Network Unit
OPGP or OPGPB	Office Principal Ground Point Bus (see also SPGP)
OSHA	Occupational Safety and Health Act
OSP	Outside Plant
PANI	Producers, Absorbers, Neutrals, and Isolated (a combined OPGP/COGB/MGB)
PBD	Power Board (Power Plant Distribution Bay – see also BDB)
PBX	Private Branch Exchange (small Customer Premises switch)

PD, PDC, PDF, etc.	Power Distributing Center, Cabinets, or Frames (secondary power distribution points for a switch – these are all given different names depending on the switch manufacturer and vintage)
PDSC	Power Distribution Service Cabinet (feeding AC to rectifiers)
PDU	Power Distribution Unit (AC distribution cabinet used in data centers)
PE	Protective Earth (international term)
(S)PGP or SPGPB	(Site) Principal Ground Point Bus for non-CO applications
PIC(S)	Plug-In Cards / Circuit Packs; or Plastic Insulated Cable
Prem	customer Premises
PSAP	Public Service Access Point (911 call center)
PUC	Public Utility Commission
PVC	Polyvinyl Chloride (conduit/pipe)
R	Resistance
RBOC	Regional Bell Operating Company
RE	Remote Electronics
REA	Rural Electrification Association
Rect(s)	Rectifier(s)
RFI	Radio Frequency Interference
RGS	Ring Ground Systems
RHW-LS	Rubberized, High-temperature, Water-resistant, Low-Smoke – a type of approved cable (referring to the insulation type) for use in DC power and grounding circuits, typically with an insulation rating of 75°C – the insulation is often soft and rubber-like (but can be hard it is is cross-linked thermoset); when ordered for telecom power, it often comes with a cotton braid covering
RMC	Rigid Metal Conduit
ROW	Right of Way
RR	Relay Rack
RSM	Remote Switch Modules
RSU	Remote Switch Units
RT	Remote Terminal

RTN (or RET)	battery Return
RUS	Rural Utilities Service (a division of the USDA)
SAI	Serving Area Interface (Cross-Connect) cabinet
SLC	Subscriber Loop Carrier
SME	Subject Matter Expert
SNI	Subscriber Network Interface (see the definition for NID)
SPCB	Single-Point Connection Bus (new term for the MGB)
SPCSS	Stored Program Control Switch System (see also ESS)
SPCW	Single-Point Connection Window (new term for the Ground Window)
SPD	Surge Protective Device (formerly known as a TVSS)
spec	Specification
SPG	Single Point Ground (isolated ground window bus)
SPOT	Single Point of Termination (old terminology for Collocator circuit cross-connect bay[s] – see also ICDF)
SRG	Signal Reference Grid
sync	Synchronization (timing)
T-1	T-carrier, signal level 1 (1.544 Mbps 4-wire copper data service)
TBB	Telecommunications Bonding Backbone (vertical riser)
TEBC	Telecommunications Equipment Bonding Conductor
TEF	Telecom Entrance Facility
telco	telecommunications company
telecom	telecommunications
TIA	Telecommunications Industry Association
TFFN	Thermo-plastic, Flexible, Fixture wire, with Nylon jacket (typically used for DC power and grounding instead of RHW or XHHW for sizes 16-20 AWG)
TGB	Telecommunications Grounding Bar (generic term that can refer to any of the sub-bars for grounding in a building, such as the MDFGB, the CEGB, COGBs, FGBs, etc.)
THHN and THWN	Thermo-plastic, High-temperature, (Water-resistant), Nylon-jacket types of approved manufactured cable (the insulation actually) for use in AC circuits, with an insulation rating of 75 or 90 degrees C.

TIP	Telephone Inside Plant (cables)
TR	Technical Requirements
TVSS	Transient Voltage Surge Suppression (now known as an SPD)
UBC	Unit Bonding Conductor
UE™	Universal Enclosure (half-buried vault)
UL®	Underwriters Laboratory
USDA	United States Department of Agriculture
V	Volts
VA	Volt-Amperes (apparent Power)
VGR	Vertical Ground Riser
W	Watts (useable Power)
WiMax	Worldwide interoperability for Microwave Access
X	Reactance (inductive or capacitive resistance to AC current flow)
XC	Cross-Connect (cabinet; for a DA)
XHHW	thermo-set, X- (cross) linked, High-temperature, Water-resistant – a type of approved manufactured cable (the insulation actually) for use in DC power and grounding circuits, with an insulation rating of 75 or 90 degrees C – the insulation is a “hard rubber-like” coating that includes a fibrous plastic liner (i.e., it doesn’t need fiber wrapping at points of impingement with metal cable racking, etc.)
yr	year
Z	Impedance (measured in Ohms)

12.2 Glossary

ACEG(C) or AC EG

AC Equipment Ground Conductor is sometimes referred to as the green-wire ground.

Arrester

An arrester is a protection device used on power lines to limit the line-to-ground surge voltage caused by lightning.

Bonding

Bonding is the permanent joining of metallic parts to form an electrically conductive path to ensure electrical continuity and the capacity to safely conduct imposed current.

Cable

A conductor with or without insulation, or a combination of conductors with insulation in a protective sheath. For individual conductors, this term is often used interchangeably with "wire".

Cable Entrance Facility (CEF)

A cable entrance facility is a dedicated space in the central office where cables enter from the outside plant network. Electrical protection measures here protect the CO from the outside plant environment. This is often a below-ground "vault".

Carbon Blocks

Carbon blocks are voltage limiting protection device containing machined blocks of carbon which provide a spark gap that discharges when the spark initialization voltage is reached. The spark initialization voltage is determined by the physical separation between the carbon blocks. (More modern TVSS devices use electronic components, like MOVs, or gas tube air gaps.)

Central Office Ground (CO GRD)

Central Office Ground is a system of conductors designed to provide a low impedance connection to the building principal ground point. The system consists primarily of a vertical equalizer, CO GRD buses, and horizontal conductors. The system provides ground reference for frames and power supplies.

Central Office Ground Bus (CO GRD BUS or COGB)

A COGB is a bus bar that references the principal ground point through the vertical equalizer. Usually, one or more of these buses is provided on each floor to permit the grounding of frames and power supplies as required. Larger buildings may have more than one of these buses.

Conductor

A conductor is a material, usually in the form of a wire, cable, or bus bar, suitable for carrying an electric current.

Conduit

Conduit is a tubular raceway for holding wires or cables, which is designed expressly for, and used solely for, this purpose. Conduit differs from pipe and metallic tubing in that it is not normally used to conduct liquids or gasses.

Duct

A duct is a single enclosed raceway for conductors or cable.

Earth Resistivity

Earth resistivity is the DC resistance of the soil on a per unit basis. The commonly used unit of measure is the meter-ohm, which refers to the resistance measured between opposite faces of a cubic meter of soil. It is the reciprocal of earth conductivity, which is expressed in an ohmic reading.

Effective Ground

Effective Ground refers to a planned and intentional connection to earth of sufficiently low impedance and having sufficient current-carrying capacity to prevent voltage buildups that may result in undue hazards to personnel and/or equipment.

Gas Tube Protector

A gas tube protector is a voltage limiting protection device containing gas tube protector units. The gas tube consists of a spark gap or gaps that discharge in a gas atmosphere within a sealed envelope.

Ground

Ground refers to a conducting connection, whether intentional or accidental, between an electrical circuit or equipment and the earth, or to some conducting body that serves in place of the earth.

Example: The earth is considered a "ground" itself. It is the principal ground point, and all other planned or unplanned grounding connections lead to the principal ground point, the earth.

Grounded

Grounded refers to a connection to earth or to some conducting body that serves in place of earth. A ground grid or office electrode system are examples of the conducting bodies that serve as a connection to earth.

Grounded Conductor

A grounded conductor refers to a system or circuit conductor that is intentionally grounded.

Example: The conductor usually referred to as the "grounded conductor" is the one identified as "the neutral" in AC circuits and "return" in DC circuits.

Grounding Conductor

A grounding conductor is used to connect equipment or the grounded circuit of a wiring system to a grounding electrode(s). Some examples of grounding conductors are as follows:

- The vertical equalizers (also called vertical risers) in multistory buildings.
- The grounding conductors used to interconnect frames in a Stored Program Controlled Switching System (SPCSS).
- The Alternating Current Equipment Ground (ACEG), also called "the green-wire", used to provide fault current return path on grounded frames in AC power systems.
- The equipment bonding jumper used to connect the grounded conductor (the neutral) to the ground bus in AC entrance switch gear.
- The grounding conductor used to interconnect frames in transmission equipment.
- The grounding conductor used to interconnect the shield for telephone cables.

Grounding Electrode Conductor

The grounding electrode conductor used to connect the grounding electrode to the equipment grounding conductor and/or to the grounded conductor of the circuit at the service equipment or at the source of a separately derived system. The following are examples of grounding electrode conductors:

- The conductor that interconnects the insulated -48 volt return bus and the main ground bus in a digital SPCSS.
- In a building's AC entrance switchgear, the conductor that connects the insulated neutral bus with the Office Principal Ground Point Bus (OPGP) or the water pipe.
- In separately derived AC power sources such as transformers, the conductor that interconnects the frame of the transformer to the nearest ground reference.

Ground Impedance

Ground impedance is the impedance of the contact between the soil and a grounding electrode. Ground impedance is not a measure of the current carrying ability of the electrode. This value should be as low as economically feasible.

Ground Mat

A ground mat (sometimes called a ground array) is an extensive system of bare conductors buried below the surface of the earth. The ground mat is intended to provide a low impedance connection to earth and equalize potentials within the area.

Ground Potential Rise (GPR)

Ground potential rise is a voltage difference between grounding electrodes caused by conduction of earth return currents. A ground potential rise occurs most often when power fault current is conducted to ground. However, when lightning currents are conducted to ground at a protector, cable pairs may be subject to GPR.

Ground Window or Single-Point Connection Window (SPCW)

A ground window is a dimensional transition zone which is the interface between the building's integrated ground plane and a given isolated ground plane.

Heat Coil

A heat coil is a current limiting protection device that grounds a conductor when overheated by current due to power contact or induction. It is used as protection against current caused by voltages insufficient to cause operation of the carbon block, gas tube or solid-state voltage limiting protection device.

House Service Panel (HSP)

The house service panel is the main AC panel(s) where commercial AC enters the building and is then distributed.

Horizontal Equalizer

A relatively low impedance conductor that interconnects buses on the same floor of a building that require the same potential reference. When a number of buses are interconnected, they are sometimes connected in a ring configuration that allows all buses to share the same path.

Incidental Ground

Incidental ground is an unplanned grounding connection.

Example: Incidental grounds usually occur during the mechanical assembly and installation of frames, raceways, piping, ducts, superstructure, and other conductive objects. When the frames are bolted to adjacent frames, a superstructure, and/or the superstructure to ceiling inserts in contact with building steel, they can form incidental ground connections.

Note: Incidental ground connections from building steel to isolated ground planes are not permitted. Incidental grounds should not be depended upon to produce a reliable electrical connection. Painted and oxidized surfaces and loose mechanical connections tend to insulate adjacent conducting surfaces.

Induction (Electric)

Electrical induction refers to voltage controlled currents induced in a telephone line by capacitive coupling from the electric field of a nearby power line.

Induction (Magnetic)

Magnetic induction refers to currents induced in a telephone line by inductive coupling from the magnetic field of a nearby power line.

Insulating Joint

An insulating joint is a splice in a cable sheath made so that continuity of the sheath, shield, metallic strength member and metallic moisture barriers are deliberately interrupted (by a capacitor that will allow AC currents to flow) to prevent the flow of electrolytic currents (DC) that may cause corrosion.

Integrated Ground Plane or Common Bonding Network (CBN)

An integrated ground plane is a set of interconnected frames that is intentionally grounded by making more than one connection to a ground reference. Examples of integrated ground planes are radio, transmission ("toll") equipment frames and the main distributing frame.

Isolated Ground Plane or Isolated Bonding Network (IBN)

An isolated ground plane is a set of interconnected frames that is intentionally grounded by making only one connection to a given ground reference. This plane, taken as a conductive unit with all of its metallic surfaces and grounding wires bonded together, is insulated from contact with any other grounded metalwork in the building. During external fault occurrences in the AC or DC power systems and when lightning current flows in the building, none of these currents can flow in the isolated ground plane because of the single-point connection. Each SPCSS grounded in this way is defined as an Isolated Ground Plane.

(Main) Aisle Feeder/Equalizer

750 kcmil horizontal equalizers extend ground potential into the different areas of a given floor. Smaller conductors (1/0 AWG through 350 kcmil) may branch off into a main aisle to further extend this ground potential. These conductors in main aisles are typically referred to as main aisle feeders or main aisle equalizers.

Main Ground Bus (MGB) or Single-Point Connection Bus (SPCB)

A single-point connection bus is a busbar (or busbars) located within the ground window that provides the electrical interface for connections between the building's integrated ground plane and the isolated ground plane.

Master Ground Bar (MGB)

A Master Ground Bar is the RUS PANI office equivalent of a Telcordia isolated-integrated ground plane system OPGP.

Multi-Grounded Neutral (MGN)

The MGN should not be confused with the ACEG. The power utility does not run an ACEG in its transmission and distribution systems. Instead, they periodically ground the neutral conductor. For this reason, the neutral conductor (among the phase conductors delivered to us) is considered “multi-grounded”.

Office Ground Electrode

An office ground electrode refers to the ground electrode whose extension into the building is used as the Office Principal Ground Point Bus (OPGPB) for connection to equipment grounding systems serving communication and computer installations.

Office Principal Ground Point Bus (OPGPB) – Also applies to SPGP(B)

An Office Principal Ground Point Bus is located near, but external to, the AC entrance switch gear. It is bonded to the neutral bus and to the frame of the AC entrance switchgear. Connect all main grounding conductors and grounding electrodes to the OPGPB. In the past, the principal ground point often was the main metallic water pipe in the building. Increased use of insulating couplings and nonmetallic water pipes in water systems now make water pipes, at worst, unreliable as grounding electrodes and, at best, supplemental grounding electrodes. A suitable grounding electrode is now required as a substitute for the water pipe. Suitable grounding electrodes, not in order of preference, are:

- Ground rings or grids
- Ground rods or ground rod arrays
- Well casings or backfilled wells or rods
- Supplemental ground fields (as defined in Section 3.2.8)
- Structural steel ground grids
- Any combination of the above

Optical Fiber Cable

A fiber optic communications cable contains optical fibers as the primary transmission medium. The cable may or may not contain metallic components. Strength members may also be non-metallic.

Peripheral Bus

In this document, peripheral bus refers to an interior conductor ring surrounding a radio equipment area (see Figures 3-6 and 7-1).

Pipe

A pipe is usually a circular tube designed to carry liquids or gasses. It is sometimes incorrectly used interchangeably with conduit or duct.

Protector

A protector is a device consisting of one or more carbon block, gas tube or solid-state protector units and a mounting assembly for limiting abnormal voltages on communications circuits.

Raceway

A raceway is a channel or enclosure designed expressly for holding wires, cables, or busbars, with additional functions as permitted in the NEC (see NEC 250 and the definitions in Section 100).

Radial Grounding or Star-IBN

A system is radially grounded when two or more sets of frames of the same system are grounded by using a separate grounding conductor from a common grounding point (see Figure 8-2).

Reference Point 0

Reference Point 0 is the point at which all grounds within a Central Office building are referenced to earth.

Separately Derived Power Supply

A separately derived power supply has electrical isolation between its input and output current carrying members (see NEC Articles 250.30 and 100; as well as Telcordia GR-295).

Serial Grounding or Chain-IBN

A system is serially grounded when a set of isolated ground frames in the system is connected in series from its associated ground window (see Figure 8-2).

Service

The "service" refers to the conductors and equipment for delivering electric energy from the serving utility to the wiring system of the premises served.

Service Entrance (see House Service Panel)

Single Point Ground (For Frames)

A single-point ground is a method used to ground a set of equipment frames for a given electronic entity that can have only one ground connection from the given set of frames to a planned ground reference. Because this set of frames does not have multi-connections (either planned or incidental) to other ground references, it is classified as an isolated ground plane. This grounding is mostly used for switches (and in a modified form for computer rooms).

Single Point Ground (For Power Supplies)

Single-point ground refers to power supplies when one current-carrying member of a separately derived power source is connected to a ground reference at only one point, it is single-point grounded. (In contrast to this, grounded conductors having more than one connection to a ground reference along their length are classified as a multi-grounded system.) Examples include:

- The DC source feeding isolated ground loads has a single ground connection from the insulated -48 volt power plant return bus to the ground window of the system.
- The entrance AC power to a building is grounded by a single connection from its neutral to the main grounding electrode.
- An example of a multi-grounded system (also known as common DC return) is:
 - A -48 volt source that feeds some integrated ground plane older digital loop carrier (DLC) and IOF carrier systems (such as SLC-96, DISC*S, D-4, some older T-carrier, etc.). These loads are grounded at the power source, at the BDFBs and at the loads (where the return conductor is also bonded to the frame ground).

Sleeve

A sleeve is a metallic or plastic hollow body typically placed through a wall, floor, or ceiling to provide a path for cabling through that wall or floor/ceiling. In this usage, a sleeve (especially a cylindrical type) is sometimes called a conduit. However, a sleeve is typically larger in diameter and shorter in length than a conduit.

A sleeve can also refer to the grounded insulating "shield" around telephone cables designed to protect them from noise or lightning.

Stringer

Above each individual aisle/lineup is a grounding conductor (typically #2 AWG). This individual aisle ground conductor is typically referred to as an (aisle) stringer because it is "strung" along the outside of the cable rack and above the lineup. The individual equipment frames/bays/relay racks tie into the stringer with #6 AWG pigtails.

Surge Protective Device (SPD) or Transient Voltage Surge Suppression (TVSS)

Transient Voltage Surge Suppression refers to a family of devices that prevent voltage surges (including those caused by lightning) from passing to sensitive electrical and electronic equipment. In telecommunications, TVSS devices are typically installed at exposed ends of copper pairs (including at the MDF and the home), and on the AC Service Entrance, among other places. TVSS devices may use carbon filaments, gas tubes, MOVs or other solid state devices, or any combination of the above.

Ufer Ground

A Ufer ground is a concrete-encased metal electrode, at least partially in contact with the earth. It is named after Herb Ufer who proved that metal (including rebar) inside of concrete in contact (especially fully or partially buried) with the earth makes an excellent ground electrode.

Vertical Equalizer (or) Riser

The vertical riser is the main vertical grounding conductor used to obtain ground reference between the CO GRD BUS on each floor and the OPGPB in a building. The conductor shall be continuous or exothermic welded, extending through the height of the building. This conductor is bonded to the OPGPB. On each floor, the CO GRD BUS connects to the vertical equalizer to form an effective earth reference.

Wire

A wire is a slender rod or filament of conductive metal (or grouping of several of these). It may or may not have insulation. The term is often used interchangeably with "cable" or "conductor".

CONTENTS

Chapter and Section	Page
13. References	13-1
13.1 Industry Standards Documents and Codes	13-1
13.2 Telcordia (formerly Bellcore) and Bell System Documents	13-2
13.3 Government Specifications	13-3
13.4 CenturyLink Technical Publications	13-3
13.5 Ordering Information	13-4
13.6 Trademarks	13-6

13. References

13.1 Industry Standards Documents and Codes

- ATIS 0600313.2008 *Electrical Protection for Telecommunications Central Offices and Similar Type Facilities*
- ATIS 0600316.2008 *Electrical Protection of Telecommunications Outside Plant*
- ATIS 0600318.2005 *Electrical Protection Applied to Telecommunications Network Plant at Entrances to Customer Structures or Buildings*
- ATIS 0600333.2007 *Grounding and Bonding of Telecommunications Equipment*
- ATIS 0600334.2008 *Electrical Protection of Communications Towers and Associated Structures*
- IEC EN-50310 *Application of Equipotential bonding and Earthing in Buildings with Information Technology Equipment, 2010 Edition*
- IEEE/ANSI C2 *National Electrical Safety Code, 2007 Edition*
- IEEE/ANSI 81 *IEEE Guide for Measuring Earth Resistivity, Ground Impedance, and Earth Surface Potentials of a Ground System, 1991 Issue*
- IEEE 142 *Recommended Practice for Grounding of Industrial and Commercial Power Systems (Green Book), 2007 Edition*
- IEEE/ANSI 487 *IEEE Recommended Practice for the Protection of Wire-Line Communication Facilities Serving Electric Power Stations, 2007 Issue*
- IEEE 1100 *Recommended Practice for Powering and Grounding Electronic Equipment (Emerald Book), 2005 Edition*
- IEEE 1657 *Recommended Practice for Personnel Qualification for Installation and Maintenance of Stationary Batteries, 2009 Edition*
- ITU-T K.27 *Bonding Configuration and Earthing Inside a Telecommunication Building, 1996 Edition*
- NECA/BICSI-607 *Standard for Telecommunications Bonding and Grounding Planning and Installation Methods for Commercial Buildings, 2011 Edition*
- NFPA 70HB *National Electrical Code (NEC) Handbook, 2011 Edition*
- NFPA 76 *Standard for the Fire Protection of Telecommunications Facilities, 2009 Edition*
- NFPA/ANSI 780 *Standard for the Installation of Lightning Protection Systems, 2011 Edition*
- TIA/EIA-222 *Structural Standards for Steel Antenna Towers and Antenna Supporting Structures, Issue G, January 2006*

- TIA/ANSI J-607-B *Generic Telecommunications Bonding and Grounding (Earthing) for Customer Premises*, Issue B, August 2011
- UL 44 *Thermoset-Insulated Wires and Cables*, Issue 17, September 2010
- UL 83 *Thermoplastic-Insulated Wires and Cables*, Issue 14, February 2008
- UL 96 *Standard for Lightning Protection Components*, Issue 5, May 2005
- UL 467 *Grounding and Bonding Equipment*, Issue 9, September 2007
- UL 486A-B *Wire Connectors*, Issue 1, November 2003
- UL 486C *Splicing Wire Connectors*, Issue 5, September 2004
- UL 486E *Standard for Equipment Wiring Terminals for Use with Aluminum and/or Copper Conductors*, Issue 4, May 2009
- UL 497 *Standard for Protectors for Paired-Conductor Communications Circuits*, Issue 7, April 2001
- UL 497A *Standard for Secondary Protectors for Communications Circuits*, Issue 3, March 2001
- UL 497B *Standard for Protectors for Data Communications and Fire-Alarm Circuits*, Issue 4, June 2004
- UL 497C *Standard for Protectors for Coaxial Communications Circuits*, Issue 2, August 2001
- UL 2200 *Stationary Engine Generator Assemblies*, Issue 1, September 1998
- UL 2201 *Portable Engine Generator Assemblies*, Issue 1, March 2009

13.2 Telcordia (formerly Bellcore) and Bell System Documents

- BR 802-001-195 *General Ground Requirements for ESS and Power*
- BR 802-010-100 *Use of a Clamp-On Resistance Meter*, Issue 1, December 1998
- BR 876-310-100 *Electrical Protection of Communications Facilities Serving Power Stations*, Issue 3, July 1985
- BSP 802-001-196 *Protective Grounding Systems – General Grounding Requirements for Data Processing Computer Systems*
- BSP 802-001-197 *Protective Grounding Systems – General Equipment Requirements for Microwave Radio and Auxiliary Station*
- BSP 802-001-198 *Protective Grounding Systems – General Equipment Grounding Requirements for AC Service Distribution Systems*
- GR-63-CORE *Network Equipment – Building System (NEBS) Requirements: Physical Protection*, Issue 3, March 2006

- GR-295-CORE *Mesh and Isolated Bonding Networks: Definition And Application To Telephone Central Offices, Issue 1, November 2004*
- GR-487-CORE *Electronic Equipment Requirements, Issue 3, April 2009*
- GR-1089-CORE *Electromagnetic Compatibility and Electrical Safety – Generic Criteria for Network Telecommunications Equipment, Issue 6, May 2011*
- GR-1275-CORE *Central Office / Network Environment Equipment Installation/Removal, Issue 11, December 2009*
- GR-1502-CORE *Central Office / Network Environment Detail Engineering, Issue 8, December 2009*
- IL-87/07-059 *Grounding Requirements for Rooftop-Mounted Antenna Towers*

13.3 Government Specifications

- MIL-HDBK-419A *Grounding, Bonding, and Shielding for Electronic Equipments and Facilities, Volume2, Issue 2, December 1987*
- MIL-F-29046 *Flooring, Raised, General Specification For, Amendment 2, March 1977*
- REA 1751F-802 *Electrical Protection Grounding Fundamentals, Issue 2, April 1994*
- RUS 1753E-001 *General Specification for Digital Stored Program Controlled Central Office Equipment, Form 522, January 1996*
- RUS 1751F-801 *Electrical Protection Fundamentals, Issue 5, May 1995*
- RUS 1751F-810 *Electrical Protection of Digital and Lightwave Telecommunications Equipment, Issue 7, September 1991*

13.4 CenturyLink Technical Publications

- PUB 77321 *Special High Voltage Protection, Issue A, June 1988*
- PUB 77339 *Enhanced 911 (E-911) Public Service Access Point (PSAP) Environmental Specifications and Equipment Installation Guidelines, Issue B, January 2010*
- PUB 77350 *Telecommunications Equipment Engineering, Installation And Removal Guidelines, Issue N, January 2007*
- PUB 77351 *Engineering Standards General Equipment Requirements, Issue G, March 2010*
- PUB 77368 *Customer Premises and Carrier Hotels Electronic Equipment Environmental Specifications and Installation Guide, Issue F, July 2009*
- PUB 77385 *Power Equipment and Engineering Standards, Issue I, September 2009*
- PUB 77419 *Specifications for the Placement of CenturyLink Equipment in Customer-Owned Outdoor Cabinets, Issue B, June 2011*

13.5 Ordering Information

All documents are subject to change and their citation in this document reflects the most current information available at the time of printing. Readers are advised to check status and availability of all documents.

American National Standards Institute (ANSI) documents from:

American National Standards Institute
Attn: Customer Service
11 West 42nd Street
New York, NY 10036
Phone: (212) 642-4900
Fax: (212) 302-1286
www.ansi.org

Alliance for Telecommunications Industry Solutions (ATIS) documents from:

Alliance for Telecommunications Industry Solutions
1200 G St. NW, Ste. 500
Washington, DC 20005
Phone: (202) 628-6380
Fax: (202) 393-5453
www.atis.org

CenturyLink Technical Publications from:

www.centurylink.com/techpub

IEC documents from:

International Electrotechnical Commission
3, rue de Varembé
P.O. Box 131
CH - 1211 Geneva 20
Switzerland
Phone: +41 22 919 02 11
Fax: +41 22 919 03 00
www.iec.ch

IEEE documents from:

IEEE Customer Service Center
445 Hoes Lane
Piscataway NJ, 08855-1331
Phone: (800) 678-4333
Fax: (732) 981-9667
www.ieee.org

ITU documents from:

International Telecommunications Union (ITU)
Place des Nations
1211 Geneva 20
Switzerland
Phone: +41 22 730 6141
Fax: +41 22 730 5194
www.itu.int

MIL SPECS from:

www.assistdocs.com

NECA documents from:

National Electrical Contractors Association
3 Bethesda Metro Center, Ste. 1100
Bethesda, MD 20814
Phone: (301) 657-3110
Fax: (301) 215-4500
www.necanet.org

NFPA documents from:

NFPA Customer Sales
1 Batterymarch Park
Quincy, MA 02269-9101
Phone: (800) 344-3555
Fax: (617) 770-0700
www.nfpa.org

Telcordia documents from:

Telcordia - Customer Services
8 Corporate Place
Piscataway, NJ 08854-4196
Telex: (201) 275-2090
Fax: (908) 336-2559
Phone: (800) 521-2673
www.telcordia.com

TIA/EIA documents from:

Telecommunications Industry Association
2500 Wilson Blvd., Ste. 300
Arlington, VA 22201
Fax: (703) 907-7727
Phone: (703) 907-7700
www.tiaonline.org

USDA RUS documents from:

United States Department of Agriculture Rural Development
1400 Independence Ave. SW
Washington, DC 20250-0107
Phone: (202) 720-8674
www.rurdev.usda.gov/RDU_Bulletins_Telecommunications.html

UL documents from:

Underwriters Laboratories
Phone: (888) 853-3503
www.ul.com

13.6 Trademarks

CEC	Trademark of Oldcastle Precast / Utility Vault
D-4	Trademark of Lucent Technologies
DISC*S	Trademark of Tellabs
DMS	Trademark of Nortel
ESS	Trademark of Lucent Technologies
SLC	Trademark of Lucent Technologies
UE	Trademark of Emerson Network Systems