

**T800 Series II**

**Ancillary Equipment**

**Service Manual**

**Issue 101**

**May 1998**

**M800-00-101**



### Head Office New Zealand

Tait Electronics Ltd  
558 Wairakei Road  
P.O. Box 1645  
Christchurch  
New Zealand  
Phone: 64 3 358-3399  
Fax: 64 3 358-3636

### Radio Systems Division

535 Wairakei Road  
P.O. Box 1645  
Christchurch  
New Zealand  
Phone: 64 3 358-3399  
Fax: 64 3 358-2825

### Australia

Tait Electronics (Aust) Pty Ltd  
186 Granite Street  
Geebung Qld 4034  
P.O. Box 679  
Virginia  
Queensland 4014  
Australia  
Phone: 61 7 3865-7799  
Toll Free: 1800 077-112  
Fax: 61 7 3865-7990

### Canada

Tait Mobile Radio Inc.  
Unit 5, 158 Anderson Avenue  
Markham  
Ontario L6E1A9  
Canada  
Phone: 1 905 472-1100  
Toll Free: 1 800 890-8248  
Fax: 1 905 472-5300

### France

Tait France Sarl  
2 Avenue de la Cristallerie  
92 316 Sèvres, Cedex  
France  
Phone: 33 1 41 14-05-50  
Fax: 33 1 41 14-05-55

### Germany

Tait Mobilfunk GmbH  
Willstätterstraße 50  
D-90449 Nürnberg 60  
Germany  
Phone: 49 911 96 746-0  
Fax: 49 911 96 746-79

### Hong Kong

Tait Mobile Radio (HK) Ltd  
Room 703A  
New East Ocean Centre  
9, Science Museum Road  
Tsim Sha Tsui East  
Hong Kong  
Phone: 852 2369-3040  
Fax: 852 2369-3009

### New Zealand

Tait Communications Ltd  
Unit 4, 75 Blenheim Road  
P.O. Box 1185  
Christchurch  
Phone: 64 3 348-3301  
Fax: 64 3 343-0558

### Singapore

Tait Electronics (Far East) Pte Ltd  
4 Leng Kee Road  
SIS Building #05-11A  
Singapore 159088  
Phone: 65 471-2688  
Fax: 65 479-7778

### Taiwan

Tait Electronics (Taiwan) Ltd  
1104, No. 142 Chung Hsiao E. Rd  
Sec. 4  
Taipei  
Taiwan  
Phone: 886 2 731-1290  
Fax: 886 2 711-6351

### Thailand

Tait Mobile Radio Ltd  
14/1 Suwan Tower  
Ground Floor  
Soi Saladaeng 1  
North Sathorn Road  
Bangrak  
Bangkok 10500  
Thailand  
Phone: 662 267-6290-2  
Fax: 662 267-6293

### United Kingdom

Tait Mobile Radio Ltd  
Ermine Business Park  
Ermine Road  
Huntingdon  
Cambridgeshire PE18 6YA  
United Kingdom  
Phone: 44 1480-52255  
Fax: 44 1480-411996

### USA

Tait Electronics (USA) Inc.  
9434 Old Katy Road  
Suite 110  
Houston  
Texas 77055  
USA  
Phone: 1 713 984-8684  
Toll Free: 1 800 222-1255  
Fax: 1 713 468-6944

## About This Manual

**Scope** This manual contains general, technical and servicing information on T800 Series II ancillary equipment.

**Format** We have published this manual in a ring binder so that "revision packages" containing additional information pertaining to new issues of PCBs, or to additional ancillary equipment, can be added as required.

**Revision Packages** Revision packages will normally be published when an ancillary equipment manual requires overhaul, or to coincide with the release of information on a new PCB, and may also contain additions or corrections pertaining to other parts of the manual.

If you return the address card at the front of this manual, you will be notified when revision packages containing new PCB information and/or text are available. You may then order as many packages as you require from your local Tait Company. Revision packages are supplied ready-punched for inclusion in your manual.

**Revision Control** Each page in this manual has a date of issue. This is to comply with various Quality Standards, but will also serve to identify which pages have been updated and when. Each page and its publication date is listed in the "List of Effective Pages", and a new list containing any new/revised pages and their publication dates will be sent with each revision package.

Any portion of text that has been changed is marked by a vertical line (as shown at left) in the outer margin of the page. Where the removal of an entire paragraph means there is no text left to mark, an arrow (as shown at left) will appear in the outer margin. The number beside the arrow will indicate how many paragraphs have been deleted.

The manual issue and revision status are indicated by the last three digits of the manual IPN. These digits start at 100 and will increment through 101, 102, 103, etc., as revision packages are published, e.g:

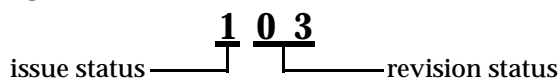

Thus, Issue 103 indicates the third revision to issue 1 and means that three packages should have been added to the manual. The issue digit will only change if there is a major product revision, or if the number of revision packages to be included means that the manual becomes difficult to use, at which point a new issue manual will be published in a new ring binder.

**PCB Information** PCB information is provided for all current issue PCBs, as well as all previous issue PCBs manufactured in production quantities, and is grouped according to PCB. Thus, you will find the

parts list, grid reference index (if necessary), PCB layouts and circuit diagram(s) for each individual PCB grouped together.

### **Errors**

If you find an error in this manual, or have a suggestion on how it might be improved, please do not hesitate to contact the Technical Writer, Tait Radio Systems Division, Tait Electronics Ltd, P.O. Box 1645, Christchurch, New Zealand.

## **Technical Information**

Any enquiries regarding this manual or the equipment it describes should be addressed in the first instance to your nearest approved Tait Dealer or Service Centre. Further technical assistance may be obtained from the Customer Support Group, Radio Systems Division, Tait Electronics Ltd, Christchurch, New Zealand.

## **Updating Equipment And Manuals**

In the interests of improving performance, reliability or servicing, Tait Electronics Ltd reserve the right to update their equipment and/or manuals without prior notice.

## **Copyright**

All information contained in this manual is the property of Tait Electronics Ltd. All rights are reserved. This manual may not, in whole or part, be copied, photocopied, reproduced, translated stored or reduced to any electronic medium or machine readable form without prior written permission from Tait Electronics Ltd.

## **Ordering Tait Service Manuals**

Service Manuals should be ordered from your nearest Tait Branch or approved Dealer. When ordering, quote the Tait Internal Part Number (IPN) and, where applicable, the version.

## **Date Of Issue**

IPN M800-00-101 T800 Series II Ancillary Equipment Service Manual  
Issue 101 published April 1998

## Table Of Contents

This manual is divided into three parts as listed below, with each part being further subdivided into sections. There is a detailed table of contents at the start of each part and/or section.

<b>Part</b>	<b>Title</b>
<b>A</b>	<b>General Servicing Procedures</b>
<b>B</b>	<b>T807/808 Switching Power Supply</b>
<b>C</b>	<b>T800-22-0000 Base Station/Repeater Rack Frame</b>

## List Of Effective Pages

I | The total number of pages in this Manual is 195, as listed below.

Page	Issue Date		Page	Issue Date	
1	30/04/98		1.6	31/08/96	
2	30/04/98		1.7	31/08/96	
3	30/04/98		1.8	31/08/96	
4	30/04/98		1.9	31/08/96	
5	30/04/98		1.10	31/08/96	(blank)
6	30/04/98		2.1	31/08/96	
7	30/04/98		2.2	31/08/96	(blank)
8	30/04/98	(blank)	2.3	31/08/96	
			2.4	31/08/96	
<b>Part A</b>			2.5	31/08/96	
			2.6	31/08/96	
I	31/08/96				
II	31/08/96	(blank)	3.1	31/08/96	
			3.2	31/08/96	(blank)
1.1	31/08/96		3.3	31/08/96	
1.2	31/08/96		3.4	31/08/96	
			3.5	31/08/96	
2.1	31/08/96		3.6	31/08/96	
2.2	31/08/96	(blank)	3.7	31/08/96	
			3.8	31/08/96	
3.1	31/08/96		3.9	31/08/96	
3.2	31/08/96		3.10	31/08/96	(blank)
4.1	31/08/96		4.1	31/08/96	
4.2	31/08/96	(blank)	4.2	31/08/96	(blank)
			4.3	31/08/96	
5.1	31/03/98		4.4	31/08/96	
5.2	31/03/98		4.5	31/08/96	
5.3	31/03/98		4.6	31/08/96	(blank)
5.4	31/03/98	(blank)			
			5.1	31/08/96	
6.1	31/08/96		5.2	31/08/96	(blank)
6.2	31/08/96	(blank)	5.3	31/08/96	
			5.4	31/08/96	
<b>Part B</b>			6.1	31/08/96	
			6.2	31/08/96	(blank)
I	31/08/96		6.3	31/08/96	
II	31/08/96	(blank)	6.4	31/08/96	
			6.5	31/08/96	
1.1	31/08/96		6.6	31/08/96	
1.2	31/08/96	(blank)	6.7	31/08/96	
1.3	31/08/96		6.8	31/08/96	
1.4	31/08/96		6.9	31/08/96	
1.5	31/08/96		6.10	31/08/96	(blank)

Page	Issue Date		Page	Issue Date	
7.1	31/08/96		8.2.39	31/08/96	(fold-out)
7.2	31/08/96	(blank)	8.2.40	31/08/96	(fold-out)
7.3	31/08/96		8.2.41	31/08/96	(fold-out)
7.4	31/08/96		8.2.42	31/08/96	(fold-out/blank)
7.5	31/08/96		8.2.43	30/11/97	
7.6	31/08/96		8.2.44	31/08/96	
7.7	31/08/96		8.2.45	31/08/96	(blank)
7.8	31/08/96		8.2.46	30/11/97	
			8.2.47	31/08/96	(fold-out)
8.1.1	31/08/96		8.2.48	31/08/96	(fold-blank)
8.1.2	31/08/96	(blank)	8.2.49	30/11/97	
8.1.3	31/08/96		8.2.50	31/08/96	
8.1.4	31/08/96		8.2.51	31/08/96	(blank)
			8.2.52	31/08/96	
8.2.1	31/08/96		8.2.53	31/08/96	(fold-out)
8.2.2	31/08/96	(blank)	8.2.54	31/08/96	(fold-out/blank)
8.2.3	31/08/96		8.2.55	31/08/96	
8.2.4	31/08/96		8.2.56	31/08/96	
8.2.5	31/08/96	(blank)	8.2.57	31/08/96	(fold-out)
8.2.6	31/08/96		8.2.58	31/08/96	(fold-out)
8.2.7	31/08/96	(fold-out)	8.2.59	31/08/96	(fold-out)
8.2.8	31/08/96	(fold-out/blank)	8.2.60	31/08/96	(fold-out/blank)
8.2.9	31/08/96				
8.2.10	31/08/96				
8.2.11	31/08/96	(blank)	<b>Part C</b>		
8.2.12	31/08/96		I	30/04/98	
8.2.13	31/08/96	(fold-out)	II	30/04/98	(blank)
8.2.14	31/08/96	(fold-out/blank)			
8.2.15	31/08/96		1.1	30/04/98	
8.2.16	31/08/96		1.2	30/04/98	(blank)
8.2.17	31/08/96	(fold-out)	1.3	30/04/98	
8.2.18	31/08/96	(fold-out)	1.4	30/04/98	
8.2.19	31/08/96	(fold-out)	1.5	30/04/98	
8.2.20	31/08/96	(fold-out/blank)	1.6	30/04/98	
8.2.21	31/08/96		1.7	30/04/98	
8.2.22	31/08/96		1.8	30/04/98	
8.2.23	31/08/96		1.9	30/04/98	
8.2.24	31/08/96	(blank)	1.10	30/04/98	
8.2.25	31/08/96				
8.2.26	31/08/96		2.1	30/04/98	
8.2.27	31/08/96	(blank)	2.2	30/04/98	(blank)
8.2.28	31/08/96		2.3	30/04/98	
8.2.29	31/08/96	(fold-out)	2.4	30/04/98	
8.2.30	31/08/96	(fold-out/blank)	2.5	30/04/98	
8.2.31	31/08/96		2.6	30/04/98	
8.2.32	31/08/96		2.7	30/04/98	
8.2.33	31/08/96	(blank)	2.8	30/04/98	
8.2.34	31/08/96		2.9	30/04/98	
8.2.35	31/08/96	(fold-out)	2.10	30/04/98	(blank)
8.2.36	31/08/96	(fold-out/blank)			
8.2.37	31/08/96				
8.2.38	31/08/96				

3.1.1	30/04/98	
3.1.2	30/04/98	(blank)
3.1.3	30/04/98	
3.1.4	30/04/98	(blank)
3.2.1	30/04/98	
3.2.2	30/04/98	(blank)
3.2.3	30/04/98	
3.2.4	30/04/98	
3.2.5	30/04/98	
3.2.6	30/04/98	
3.2.7	30/04/98	
3.2.8	30/04/98	
3.2.9	30/04/98	
3.2.10	30/04/98	
3.2.11	30/04/98	(fold-out)
3.2.12	30/04/98	(fold-out)
3.2.13	30/04/98	(fold-out)
3.3.1	30/04/98	
3.3.2	30/04/98	(blank)
3.3.3	30/04/98	
3.3.4	30/04/98	(blank)
3.3.5	30/04/98	(fold-out)
3.3.6	30/04/98	(fold-out)
3.3.7	30/04/98	(fold-out)
3.3.8	30/04/98	
3.3.9	30/04/98	
3.3.10	30/04/98	
3.3.11	30/04/98	
3.3.12	30/04/98	(blank)



## Part A General Servicing Procedures

This part of the manual is divided into the sections listed below. These sections provide some general and advisory information on servicing procedures, a brief history of T800 programming software, and a list of Technical Instructions pertaining to T830 Series equipment.

Section	Title	Page
<b>1</b>	<b>General</b>	<b>1.1</b>
1.1	Caution: CMOS Devices	1.1
1.2	Caution: Beryllium Oxide & Power Transistors	1.2
<b>2</b>	<b>Mechanical</b>	<b>2.1</b>
2.1	Pozidriv Recess Head Screws	2.1
2.2	Disassembly/Reassembly	2.1
<b>3</b>	<b>Component Replacement</b>	<b>3.1</b>
3.1	Leaded Components	3.1
3.1.1	Desoldering Iron Method	3.1
3.1.2	Component Cutting Method	3.1
3.2	Surface Mount Devices	3.2
<b>4</b>	<b>To Remove Cased Mica Capacitors</b>	<b>4.1</b>
<b>5</b>	<b>Software History</b>	<b>5.1</b>
5.1	BASEPROG V1/PGM800 V2	5.1
5.2	PGM800 V2.01	5.1
5.3	PGM800 V2.21	5.2
5.4	PGM800Win V1.00	5.2
<b>6</b>	<b>Technical Instructions</b>	<b>6.1</b>

Figure	Title	Page
1.1	Typical Anti-static Bench Set-up	1.1



# 1 General

If further information is required about any ancillary equipment or this Manual, it may be obtained from Tait Electronics Ltd or accredited agents. When requesting this information, please quote the equipment type number (e.g. T807-10) and serial number. In the case of the Service Manual quote the Tait Internal Part Number (IPN), e.g. M800-00-100, and for circuit diagrams quote the 'Title', 'IPN' and 'Issue'.



## 1.1 Caution: CMOS Devices

This equipment contains CMOS Devices which are susceptible to damage from static charges. Care when handling these devices is essential. For correct handling procedures refer to the manufacturers' data books, e.g. Philips data books covering CMOS devices, or Motorola CMOS data books, Section 5 'Handling', etc.

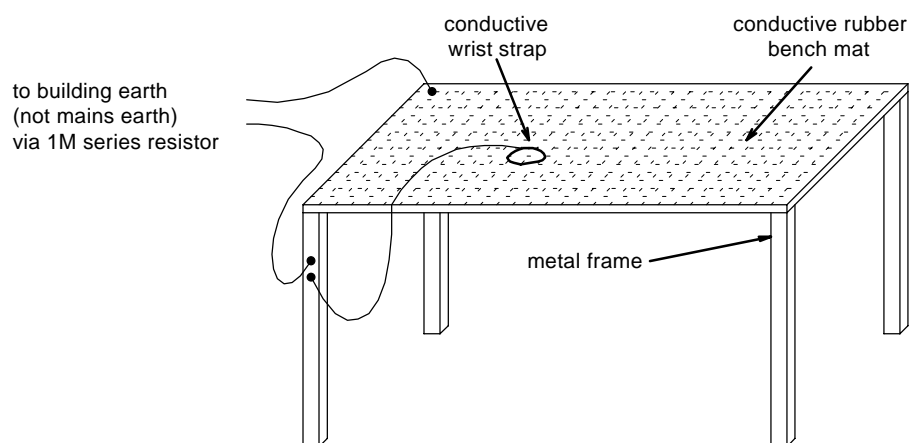

*Figure 1.1 Typical Antistatic Bench Set Up*

An antistatic bench kit (refer to Figure 1.1) is available from Tait Electronics Ltd under the usual consumable goods ordering system. The kit is held in stock under IPN 937-00000-34 and contains:

- 1 conductive rubber bench mat
- 1 earth lead to connect the mat to ground (c/w 1M series resistor)
- 1 wrist strap
- information leaflet.



## 1.2 **Caution: Beryllium Oxide & Power Transistors**

The power transistors in current use all contain some beryllium oxide. This substance, while perfectly harmless in its normal solid form, can become a severe health hazard when it has been reduced to dust. For this reason the power transistors should not be broken open, mutilated, filed, machined, or physically damaged in any way that can produce dust particles.

## **2 Mechanical**

### **2.1 Pozidriv Recess Head Screws**

Pozidriv recess head screws are the preferred standard on all Tait manufactured equipment. The very real advantages of this type of screw will not be realised unless the correct screwdrivers are used by servicing personnel.

### **2.2 Disassembly/Reassembly**

Instructions on disassembly/reassembly for individual equipment are given in the relevant part of this manual.



## 3 Component Replacement

### 3.1 Leaded Components

Whenever components are removed from or fitted to a PCB, care must be taken to avoid damage to the track. The two satisfactory methods of removing components from PTH PCBs are detailed below.

*Note:* The first method requires the use of a desoldering station, e.g. Philips SBC 314 or Pace MBT-100E.

#### 3.1.1 Desoldering Iron Method

Place the tip over the lead and, as the solder starts to melt, move the tip in a circular motion.

Start the suction and continue the movement until 3 or 4 circles have been completed.

Remove the tip while continuing suction to ensure that all solder is removed from the joint, then stop the suction.

**Before** pulling the lead out, ensure it is not stuck to the plating.

If the lead is still not free, resolder the joint and try again.

*Note:* The desoldering iron does not usually have enough heat to desolder leads from the ground plane. Additional heat may be applied by holding a soldering iron on the tip of the desoldering iron (this may require some additional help).

#### 3.1.2 Component Cutting Method

Cut the leads on the component side of the PCB.

Heat the solder joint **sufficiently** to allow **easy** removal of the lead by drawing it out from the component side: do **not** use undue force.

Fill the hole with solder and then clear with solderwick.

## 3.2 Surface Mount Devices

**Caution:**

Surface mount devices (SMDs) require special storage, handling, removal and replacement techniques. This equipment should be serviced only by an approved Tait Dealer or Service Centre equipped with the necessary facilities. Repairs attempted with incorrect equipment or by untrained personnel may result in permanent damage. If in doubt, contact Tait Electronics Ltd or your nearest Tait Branch or Subsidiary.



## 4 To Remove Cased Mica Capacitors

Cased mica capacitors can be removed by heating the top with a heavy-duty soldering iron and gently lifting the capacitor off the PCB with a solder-resistant spike or equivalent.



## 5 Software History

23/11/89	BASEPROG Version 1
23/08/90	PGM800 Version 2
11/06/91	PGM800 Version 2.01
03/10/95	PGM800 Version 2.21
28/06/96	PGM800Win Version 1.00
18/08/97	PGM800Win Version 2.00

### 5.1 BASEPROG V1/PGM800 V2

T800 programming software was originally developed as BASEPROG V1 and released as PGM800 V2.

### 5.2 PGM800 V2.01

The major changes introduced with V2.01 are as follows:

- Full support for different display adaptors.
- Programming of CTCSS frequency data (optional) for individual channels.
- Full cursor control in edit mode.
- User selectable output file format (hex or binary).
- Support for wider range of T800 equipment.
- DOS shell facility implemented.
- CTCSS defeat possible when CTCSS tone is not selected.
- Channel numbering changed from 0-127 to 1-128.
- An "X" included on the printout to indicate that there are 8 switches on the DIP switch and the state of the MSB is dependent on the size of the EPROM used.

**Note:** The data files produced by BASEPROG V1.0 are still compatible with PGM800 V2.01.

## 5.3 PGM800 V2.21

PGM800 V2.21 is an updated and expanded version of the earlier PGM800 V2.01 software.

PGM800 V2.21 includes many new and improved features over PGM800 V2.01. There are a number of changes to the user interface to make data entry and editing significantly easier.

Major changes are outlined below:

- Includes several new radio models which are not programmable with PGM800 V2.01.
- Default file names with 'dash' are saved with 'dash' instead of 'underscore'.
- Default file extension in Save File page is BIN instead of HEX.
- Out of range frequencies will result in warning messages, but will still be accepted as valid entries.
- Channel numbers are selectable between 0-127 and 1-128.
- Automatic insertion feature to input frequencies.

**Note:** The datafiles produced by BASEPROG V1.0 and PGM800 V2.01 are still compatible with PGM800 V2.21.

## 5.4 PGM800Win V1.00

PGM800Win V1.00 is different in concept from DOS versions of PGM800 in that it is Windows<sup>TM</sup> driven. It includes many new and improved features over DOS versions of PGM800.

Major changes are outlined below:

- The Windows environment makes data entry and editing significantly easier.
- Includes several new radio models which are not programmable with DOS versions of PGM800.
- Out of range frequencies will result in warning messages and will not be accepted for entry into the standard library module. User defined modules can be created allowing variation from the standard library module.
- Channel numbers default to 0-127 to match the EPROM memory locations, however the user can change the setting so that the channel numbers run from 1-128 to suit his/her particular needs.

**Note:** The datafiles produced by BASEPROG V1.0 and all DOS versions PGM800 are still compatible with PGM800Win V1.00.

## 5.5 PGM800Win v2.00

PGM800Win V2.00 is an upgraded and expanded version of PGM800Win V1.0. It has been developed specifically for T800 Series II base stations but also has the capability of programming Series I equipment.

Major changes are outlined below:

- The Windows environment makes data entry and editing significantly easier.
- Includes several new radio models which are not programmable with DOS versions of PGM800.
- Out of range frequencies will result in warning messages and will not be accepted for entry into the standard library module. User defined modules can be created, allowing variation from the standard library module.
- Channel numbers default to 0-127 to match the EPROM memory locations, however the user can change this setting so that the channel numbers run from 1-128 to suit his/her particular needs.
- The ability to program T800 Series II base station modules via serial communications.
- Deviation and reference modulation settings are written automatically to the radio.
- Extra information that is not stored in the radio (but is information relevant to the radio) can be saved to a file on disk (e.g. note field, auxilliary pin names etc).

**Note:** The datafiles produced by BASEPROG V1.0. all DOS versions of PGM800 and PGM800Win V1.0 are still compatible with PGM800Win V2.00.



## **6 Technical Instructions**

From time to time Technical Instructions (TIs) are issued by the Radio Infrastructure Engineering Division of Tait Electronics. These TIs may be used to update equipment or information, or to meet specific operational requirements.

TIs applicable to specific T800 Series ancillary equipment are listed in the relevant part of this manual.





## Part B T807/808 Switching Power Supply

This part of the manual is divided into eight sections, as listed below. There is a detailed table of contents at the start of each section

*Note:* The T807/808 has been manufactured with three different issues of PCB as indicated by the last two digits of the IPN which will be -03, -05 or -07. The information in this manual applies to all three issues of PCB unless otherwise stated in the text.

<b>Section</b>	<b>Title</b>
<b>1</b>	<b>General Information</b>
<b>2</b>	<b>Circuit Operation</b>
<b>3</b>	<b>Introduction To Servicing</b>
<b>4</b>	<b>Initial Set-up &amp; Adjustment</b>
<b>5</b>	<b>Functional Testing</b>
<b>6</b>	<b>Fault Finding</b>
<b>7</b>	<b>Installation</b>
<b>8</b>	<b>PCB Information</b>



# 1 T807/808 General Information

This section provides a brief description of the T807/808 Switch Mode Power Supply along with detailed specifications

The following topics are covered in this section.

<b>Section</b>	<b>Title</b>	<b>Page</b>
<b>1.1</b>	<b>Introduction</b>	<b>1.3</b>
<b>1.2</b>	<b>Specifications</b>	<b>1.4</b>
1.2.1	Introduction	1.4
1.2.2	General	1.4
1.2.3	EMC Conformity	1.5
1.2.4	Safety Approvals	1.5
1.2.5	AC Mains Input	1.5
1.2.6	Output	1.6
1.2.7	Battery Charging Operation	1.8
<b>1.3</b>	<b>Versions</b>	<b>1.9</b>



## 1.1 Introduction

The T807/808 is a heavy duty, lightweight switching power supply capable of supplying up to 15A (T807) or 25A (T808) at 11 to 14V DC. The units require a mains supply of 230V/50Hz or 115V/60Hz (nominal values) which can be internally selected with a switch (if fitted) or wire links. Remote sensing of the output voltage is available as a standard feature: if connected, it will ensure that the output voltage remains within  $\pm 1\%$  of the preset level from no-load to the full specified load, over the specified mains voltage and temperature ranges (refer to Section 7.6).

The T807/808 power supply is designed to power T800 series base stations. Specifically, the T807 will power 50W base stations, while the T808 will provide the current requirements for 100W base stations.

Electromagnetic compatibility (EMC) and operator safety are both important and critical parameters for the trouble free functioning of a switching power supply. Refer to Section 1.2.3 (EMC) and Section 1.2.4 (safety) for current specifications.

The T807/808 is protected against damage caused by faults in the line or load, or by temperature variations (refer to Section 1.2 for specifications). The protection features include:

- mains transient suppression
- mains inrush current limiting
- mains undervoltage lockout
- soft start
- output current limiting
- output voltage limiting
- output reverse polarity protection
- overtemperature shutdown.

The output voltage and current limit and overvoltage points are all adjustable and are preset during manufacture.

**Note:** On earlier model power supplies with an issue 03 PCB, the overvoltage point is **not** adjustable.

The T807/808 can be used to float charge a 12V battery under constant voltage conditions. The current limit circuit prevents the charging current from being excessive if the battery is completely discharged, and the internal rectifier diode will blow the external fuse in the event of the battery being accidentally connected in reverse. (refer to Section 7.5). An alarm output provides a logic 0 (0V) in the case of a mains and/or power supply failure, even if a battery is connected to the 13.8V output.

**Note:** On issue 03, a transient suppression diode across the power supply output prevents any damage if the battery is accidentally connected in reverse.

A T807/808 may be housed together with other Tait fixed equipment modules in a standard 484mm (19") rack frame, where it occupies the space of one standard 60mm module, to give an attractive and convenient installation.

## 1.2 Specifications

### 1.2.1 Introduction

The performance figures given are minimum figures, unless otherwise indicated, for equipment operating at standard room temperature (+22°C to +28°C).

Where applicable, the test methods used to obtain the following performance figures are those described in the EIA specification. However, there are several parameters for which performance according to the CEPT specification is given.

Details of test methods and the conditions which apply for Type Approval testing in all countries can be obtained from Tait Electronics Ltd.

Three different issues of PCB are covered in this manual, as classified by the last two digits of the IPN. Throughout this manual, differences in the specification or operation of the various issues of power supply are identified using these digits.

### 1.2.2 General

Basic Power Supply Concept	.. switched mode technology pulse width modulation
Switching Frequency	.. 166kHz typical
Overtemperature Protection	.. shuts down when main transformer temperature rises above 105°C
Cooling:	
T807	.. convection
T808	.. convection and forced air (fan)
Power On/Off Switch & LEDs:	
On: Switching Enabled	.. green "On" LED glows
Off: Switching Disabled	.. red "Standby" LED glows
Other LEDs on <b>Issues 05 and 07 only</b> :	
Overcurrent	.. red "Overload" LED glows
Overvoltage	.. green "On" and red "Overload" LEDs flash on and off
<b>Note:</b>	To remove the mains voltage from the PCB, disconnect the IEC mains connector.
Efficiency:	
T807	.. 80%, 10-15A load typical
T808	.. 80%, 15-25A load typical

**Temperature Range:**

Operation Within Specification	.. -10°C to +60°C
Operational	.. down to -30°C

**Isolation:**

Input To Output	.. 3000V AC, 50Hz, 1 minute
Input to Chassis/Earth	.. 1500V AC, 50Hz, 1 minute
Output To Chassis/Earth	.. 500V AC, 50Hz, 1 minute

**Dimensions:**

Height	.. 191mm
Width	.. 60mm
Length	.. 330mm

Weight	.. 2.5kg
--------	----------

**1.2.3 EMC Conformity**

EMC	.. all equipment bearing the above logo conforms with EEC EMC Directive 89/336 and is in accordance with the requirements of ETS 300 279.
-----	---

**Note:** Refer to Section 3.1.6 for **customer requirements** in order to meet the above emissions specification.

**1.2.4 Safety Approvals**

Safety	.. complies with IEC950, EN60950 & AS3260
--------	---

**Note:** Refer to Section 3.1.7 for **customer requirements** in order to meet the above safety specification.

**1.2.5 AC Mains Input**

Voltage	.. 200-264V or 100-135V, 50/60Hz (selection by internal switch or wire links)
---------	--

Overvoltage	.. infrequent surges of up to 276V AC and less than a few hours' duration will not damage the T807/808
-------------	--

## Transient Suppression Threshold:

230V	.. 276V AC
115V	.. 140V AC

Undervoltage Lockout:  
(no load to full load)

230V	.. <185V AC, 175V AC typical
115V	.. <95V AC, 90V AC typical

## Input True RMS Current:

T807- 230V $\pm 10\%$	.. 2.5A max.
115V $\pm 10\%$	.. 4A max.
T808- 230V $\pm 10\%$	.. 4A max.
115V $\pm 10\%$	.. 6A max.

## Input Fuse (Internal):

T807	.. 5A slow blow
T808	.. 8A slow blow

Connection .. via IEC plug on rear panel

Power Factor @ Full Load .. >0.55  
(exact factor depends on impedance of mains supply)

## 1.2.6 Output

Voltage .. 13.8V DC (adjustable 11-14V)

Voltage Regulation ..  $\pm 1\%$   
(remote sensing connected;  
over specified load, temperature  
and mains voltage range)

## Current

## Continuous Operation Up To +40°C:

T807	.. 0-15A DC
T808	.. 0-25A DC

## Continuous Operation Up To +60°C:

T807	.. 0-12A DC
T808	.. 0-22A DC



## Duty Cycle Operation Up To +60°C:

75% Tx (&lt;30 minute period)

T807	.. 15A DC
T808	.. 25A DC

25% Rx (&lt;30 minute period) .. 1A DC

**Note:** These current ratings apply to a typical remote sensing operation, i.e.13.8V at the load terminals with <0.5V drop across the wiring from the power supply to the load.

Output Overvoltage Protection (**Issue 03**):  
(zener transient suppression diode)

Voltage Threshold	.. 16V $\pm$ 5%
Peak Power (1ms, 22.5V)	
T807	.. 600W
T808	.. 1500W

**Note:** This device is likely to short circuit if the peak power rating is exceeded and will need to be replaced.

Output Overvoltage Protection (**Issues 05 & 07**):  
(main rectifier diode)

Voltage Threshold	.. 15V $\pm$ 2%
	(15A (T807) or 25A (T808) at 240V input)
	17.8V
	(Zero load at 200V input)

Output Hum & Noise:  
(mains voltage 230V  $\pm$ 10%, TA = 25C  
100/120Hz (@ max. rated load)

.. <20mV pp
<10mV RMS

## Wide Band Noise (200Hz to 30MHz):

Load 0 To 1A	.. <20mV pp
Load 1A To Full Load	.. <10mV pp

## Current Limit:

T807	.. 16A
T808	.. 27A

Mains And/Or Power Supply Failure  
Alarm Output:

OK	.. +Vout (13.8V typ.) via 1k resistor
Fail	.. -Vout (0V) via 11k resistors

## Output Connectors:

Type	.. screw clamp
Flexible Wire Size	.. 0.5 to 4.0mm
Current Rating	.. 36A
Insulation Stripping Length	.. 13mm

## Remote Sense &amp; Fail Alarm Connectors:

Type	.. screw clamp
Flexible Wire Size	.. 0.5 to 1.5mm
Current Rating	.. 16A
Insulation Stripping Length	.. 10mm

## 1.2.7 Battery Charging Operation

Reverse Polarity Protection (**Issue 03**) .. via internal zener transient suppression diode and external fuse

Reverse Polarity Protection (**Issues 05 & 07**) .. via internal main rectifier diode and external fuse

**Note 1:** For safe operation an external fuse **must** be fitted in the battery line.

**Note 2:** The T807/808 does not compensate for the temperature dependence of the battery.

Reverse Bleed Current .. <5mA  
(mains and/or power supply off)

Battery Type .. constant voltage charging (e.g. conventional automotive lead acid)

## 1.3 Versions

- T807-10: Switching power supply, 13.8V DC output 230/115V (50/60Hz) internally selected mains inputs (factory set to 230V/50Hz) 15A continuously rated power supply for 50W base stations
- T808-10: Switching power supply, 13.8V DC output 230/115V (50/60Hz) internally selected mains inputs (factory set to 230V/50Hz) 25A continuously rated power supply for 100W base stations



## 2 T807/808 Circuit Operation

This section provides a basic description of the circuit operation of the T807/808 Switch Mode Power Supply.

The following topics are covered in this section.

<b>Section</b>	<b>Title</b>	<b>Page</b>
<b>2.1</b>	<b>Introduction</b>	<b>2.3</b>
<b>2.2</b>	<b>Mains Input Circuitry</b>	<b>2.3</b>
<b>2.3</b>	<b>Undervoltage Lockout &amp; Fan Control</b>	<b>2.3</b>
<b>2.4</b>	<b>Main Isolation Transformer T1, Snubbing Network &amp; Output Rectifier</b>	<b>2.4</b>
<b>2.5</b>	<b>Output Filter &amp; Minimum Load</b>	<b>2.4</b>
<b>2.6</b>	<b>Output Voltage Regulation &amp; Switching Transistor Drive</b>	<b>2.4</b>
<b>2.7</b>	<b>Current Limit Circuitry</b>	<b>2.5</b>
<b>2.8</b>	<b>Output Overvoltage &amp; Reverse Polarity Protection</b>	<b>2.5</b>
2.8.1	Issue 05 & 07	2.5
2.8.2	Issue 03	2.5
<b>2.9</b>	<b>Overtemperature Protection</b>	<b>2.6</b>
<b>2.10</b>	<b>Mains And/Or Power Supply Fail Alarm</b>	<b>2.6</b>
<b>2.11</b>	<b>Noise Modulator</b>	<b>2.6</b>
2.11.1	Issue 05 & 07	2.6
2.11.2	Issue 03	2.6



## 2.1 Introduction

The Tait T807/808 switched mode power supply uses the well proven conventional half-bridge, push-pull topology.

Regulation of the output voltage with varying mains input voltage and load conditions is provided by pulse width modulation of power MOSFET transistors at the primary of the main isolating transformer.

## 2.2 Mains Input Circuitry

When the mains supply is first connected to the unit, R3 will limit the maximum inrush current to an acceptable level. The large filter capacitors (C9 to C12) at first show a very low impedance, which would result in excessive inrush current without R3. Once the supply has begun to function, RLY1 will switch, shorting out R3 and avoiding excessive power dissipation in R3.

The incoming mains is filtered to remove noise and spikes, R2 and R49 providing protection against high voltage spikes that may be on the mains supply. In 230V mode, D1 to D4 act as a conventional bridge rectifier and C9 to C12 are the smoothing capacitors. In 115V mode, D1 and D2 together with C9 to C12 form a conventional voltage doubler circuit to provide the same overall DC voltage as in 230V mode. R4 and R7 serve to equalise the voltage appearing across the series connected capacitors. C9 to C12 are high temperature, high ripple current capacitors. C14 and C13 are low loss, high frequency capacitors and together with T1, Q1 and Q2 form a conventional half-bridge, push-pull circuit, operating at 166kHz. D14, D15, D18 and D19 provide reverse voltage protection for Q1 and Q2.

## 2.3 Undervoltage Lockout & Fan Control

R50 and D31 provide a 5.6V reference to the 2 comparators formed by IC3. IC3 (pins 1, 2 & 3) is a comparator that is configured with R5, R6, R8, R53 and R54 to detect low AC input conditions. The values are such that for an AC input of 185V [95V] or less, the comparator shuts down the main control circuitry via IC4 pin 10. R52 provides approximately 5V hysteresis to prevent on/off oscillations due to mains fluctuations caused by loading when the supply turns on.

The purpose of the comparator formed by IC3 (pins 5, 6, & 7) and R55 is to prevent the fan from being activated when the ambient temperature drops below -10C, as the bearings inside the fan become prone to excessive wear. R59 provides a few degrees of hysteresis.

## 2.4 Main Isolation Transformer T1, Snubbing Network & Output Rectifier

T1 provides the required isolation between input and output and its small size is due to the high operating frequency and low loss ferrite core. This transformer is hi-pot tested to 3750V to ensure compliance with the most stringent VDE safety regulations.

The main secondary winding is centre tapped, thus requiring only 2 diodes (D43) to provide full-wave rectification, resulting in reduced power loss. R11, C15, R79, C66 and C67 provide some high frequency snubbing. The effect of this snubbing is twofold: firstly, it reduces high frequency spikes due to leakage inductance, and, secondly, it shapes the load line, resulting in reduced switching losses within Q1 and Q2.

## 2.5 Output Filter & Minimum Load

T5, C68 to C73, C76 and C78 reduce the 166kHz ripple to an acceptable level, while C74, C75, L6, C79, C80 and C81 reduce the level of higher frequency noise components.

Q9 switches in R81, R82 and RLY1 which serve as a minimum load to enhance stability. Q9 is activated via D41 only when the supply is active. This ensures that R81, R82 and RLY1 will not drain any back-up batteries that might be present on the supply output, while the supply is switched off or the mains supply is interrupted.

## 2.6 Output Voltage Regulation & Switching Transistor Drive

The output voltage is sampled via R84 and R83 (or SKT 7 if remote sense is used), fed to IC8 (a programmable high stability zener diode), and the error voltage transmitted by IC7 to the pulse width modulator IC (IC4). R91 to R96 and C86 to C89 form the stabilisation network which ensures good transient response and loop stability. IC4 contains an oscillator whose frequency is determined by R71 and C59. R72 sets the dead time between pulses to approximately 1s. IC4 modulates the width of the output pulses and is buffered by the high current CMOS drivers, IC5 and IC6. The output from the buffers feeds into T3 which provides the isolated and correctly phased drive to Q1 and Q2. R18 and R20 provide low resistance to the FET gates which, in their normal high impedance states, are prone to spurious turn-on. R17 and R19 lower the Q of the gate drive circuitry in order to prevent excessive ringing which can otherwise cause the FETs to turn on at the wrong time.



## 2.7 Current Limit Circuitry

T2 is a current transformer and the current sampled is converted to voltage by R12. D5 to D8 rectify the sampled waveform which is then sent to a current limit comparator IC1 (pins 1, 2 & 3). This current limit is set at 10% above the normal load capability of the supply. Comparator IC1 (pins 5, 6 & 7) is responsible for protecting the supply against short circuit conditions and limits the short circuit current to a level that is safe for extended periods (approximately 90% of output capability).

**Note:** *Issue 05 & 07.* An indication of overcurrent and approaching overcurrent is had by LED D23. This LED starts to glow approximately  $\frac{1}{2}$  Amp lower than the current limit set point.

## 2.8 Output Overvoltage & Reverse Polarity Protection

### 2.8.1 Issue 05 & 07

Protection against reverse polarity situations is provided by D43, the main rectifier diode. The supply has an overvoltage protection circuit based on sampling the AC voltage from T1. D38 detects this voltage and R40, 43, 45, C18 and 19 filter the waveform to extract a voltage which is very nearly proportional to the output voltage of the power supply. The voltage is compared to a presettable reference by IC1 (pins 1, 2 & 3). If the sampled voltage is higher than the reference, IC1 outputs a high to trigger the shutdown circuitry. Overvoltage is indicated by both "On" and "Overload" LEDs flashing on and off. Overvoltage can be caused by a failure in the remote sense circuitry outside of the power supply.

### 2.8.2 Issue 03

Protection against reverse polarity situations is provided by D46, a special high energy diode that reacts instantly to overvoltage DC or spikes. If an overvoltage condition persists which may cause excessive power dissipation, D46 will become short circuit and will need to be replaced before proper operation of the power supply can resume. D46 also provides some level of protection against reverse polarity connection, as it also acts as a normal diode. The level of protection afforded by D46 is only a "first level" approach, in that it protects mainly the supply itself. As protection is very dependent on system configurations, further protection should be determined and implemented by the system engineer (refer also to Section 7).

## 2.9 Overtemperature Protection

Protection against overheating is provided by thermal cut-out TC1. Should the temperature of the main transformer (T1) rise to an unsafe level, TC1 will interrupt the supply voltage to the control circuitry and the supply will shut down. There is some hysteresis in TC1 and only after the temperature has dropped by approximately 5°C will it restore power to the control circuitry, thus restoring normal operation.

## 2.10 Mains And/or Power Supply Fail Alarm

In the case of a mains and/or power supply failure, a "logic 0" (0V) is available at the "Mains/PS Fail Alarm" output, even with a battery connected across the main DC output.

If there is no fault with the mains or power supply, the main DC output voltage (typ. +13.8V) is supplied to this alarm output via Q8 and R99.

## 2.11 Noise Modulator

### 2.11.1 Issue 05 & 07

Q11 and Q12 form the white noise circuit and are further amplified/buffered by Q13. The noise modulates the frequency of oscillation of IC4, the switched mode control IC. The purpose of the noise modulator is to spread the discrete harmonic frequencies energy of the switching circuits over a wide bandwidth so that possible interference is minimised. This results in an overall reduction in noise of approximately 10dB.

### 2.11.2 Issue 03

A noise modulator PCB is available as an add-on for Issue 03 PCBs, under IPN 220-01268-00. This solders on to TP4 and works as described above.

## 3 T807/808 Introduction To Servicing

This section provides specific information on servicing procedures for the T807/808 and should be read in conjunction with Part A (General Servicing Procedures) of this manual.

The following topics are covered in this section.

Section	Title	Page
<b>3.1</b>	<b>General</b>	<b>3.3</b>
3.1.1	Warning: Lethal Voltages	3.3
3.1.2	Caution: Ventilation	3.3
3.1.3	Caution: Replacing Components Connected To The Mains	3.3
3.1.4	Caution: Handle With Care	3.4
3.1.5	Caution: Heatsink/Case Temperature	3.4
3.1.6	Caution: Earthing Of Rack Frame	3.4
3.1.7	Caution: Cabinet Requirements To Meet Safety Specifications	3.4
<b>3.2</b>	<b>Mechanical</b>	<b>3.5</b>
3.2.1	Construction	3.5
3.2.2	Disassembly Instructions	3.5
3.2.2.1	To Gain Access To The Component Side Of The PCB	3.5
3.2.2.2	To Gain Access To The Solder Side Of The PCB	3.5
3.2.3	Reassembly Instructions	3.6
3.2.4	Screw Torques	3.6
<b>3.3</b>	<b>Component Replacement</b>	<b>3.7</b>
3.3.1	Critical Components	3.7
3.3.2	To Replace The Power MOSFET Transistors (Q1 & Q2)	3.7
3.3.3	To Replace The Output Rectifier (D43)	3.8
<b>3.4</b>	<b>Technical Instructions</b>	<b>3.9</b>



## 3.1 General

If you require further information about the T807/808 or this manual, contact your nearest authorised Tait Dealer or Service Centre. Further assistance may be obtained from the Customer Support Group, Radio Infrastructure Division, Tait Electronics Ltd, Christchurch, New Zealand.

When requesting this information, please quote the equipment type number (e.g. T807-10) and serial number. In the case of the service manual quote the Tait Internal Part Number (IPN), e.g. M800-00-100, and for circuit diagrams quote the "Title", "IPN" and "Issue".



### 3.1.1 Warning: Lethal Voltages

The T807/808 power supply contains voltages that may be lethal.

Disconnect the mains IEC connector and wait for 5 minutes for the internal voltages to drain away before dismantling.

The power on/off switch does **not** isolate the power supply from the mains. It disables (or enables) only the switching control circuitry, i.e. output power on/off.

Servicing should be carried out only by qualified technicians and should be attempted only when powered through a mains isolating transformer of sufficient rating. It is **strongly recommended** that the mains supply to the whole of the repair and test area is supplied via an **earth leakage circuit breaker**.



### 3.1.2 Caution: Ventilation

Always ensure there is adequate ventilation around this unit and **do not** operate it in a sealed cabinet. The MTBF will decrease if the airflow is blocked. As a rule of thumb the life expectancy of this unit will approximately halve with every 10°C rise in temperature.

It is therefore recommended to:

- keep the ambient temperature low
- ensure that airflow is not restricted.



### 3.1.3 Caution: Replacing Components Connected To The Mains

To maintain operator safety and protection against fire, it is imperative that components connected to the mains supply (e.g. fuse, X & Y capacitors, filter chokes, etc.) and those that are critical to maintain isolation (optocouplers, transformers, etc.) are replaced **only** with their new, original equivalent.

To maintain performance levels it is strongly recommended that this policy is applied to every component that is replaced.

### 3.1.4 Caution: Handle With Care

Although this is a lightweight unit, it contains a number of quite heavy and fragile individual components which are mounted directly on the PCB. Severe mechanical shock may damage the PCB (i.e. solder joints, copper tracks) and/or components (i.e. fragile ferrite magnetic materials).

### 3.1.5 Caution: Heatsink/Case Temperature

The 2 covers of this power supply act as heatsinks for the internal power semi-conductors. Under some conditions the top and bottom sections of these covers and internal heatsinks may reach temperatures of over 100C. Handle with extreme care after prolonged operation.

### 3.1.6 Caution: Earthing Of Rack Frame



The power supply case is internally connected to mains earth. Because the unit's case and the rack frame in which it is usually installed are painted, a secure electrical earthing connection between the unit and the rack is **not** guaranteed (i.e. it is reliant on breaking through the paint coating).

It is therefore strongly advised that an additional and secure electrical connection is provided by means of the supplied earth lead (refer to Section 7.2). Failure to do so may result in harmful voltage potentials between the power supply and rack frame, and/or miscellaneous power supply switching noise problems in both receivers and transmitters.

**Note:** Failure to comply with the above instruction may result in the power supply falling short of the emissions requirements of ETS 300-279.

### 3.1.7 Caution: Cabinet Requirements To Meet Safety Specifications



In order to meet stringent safety obligations, it is imperative that the power supply is mounted in a cabinet which meets the requirements of IEC950. Specifically the top and sides of the cabinet must comply with one of the following:

- holes must not exceed 5mm in any dimension, or
- holes must not exceed 1mm in width regardless of length, or
- side panels must be provided with louvres that are shaped to deflect outwards an external vertically falling object, or
- tops must be so constructed that direct, vertical entry of a falling object is prevented from reaching bare parts by means of a trap or restriction.

Additionally, for units mounted in a slimline configuration, the bottom of the cabinet must be constructed so as to contain any material emitted from the unit under fault conditions which could ignite the supporting surface. ***If in doubt, refer to IEC950 or your nearest approved Tait Dealer or Service Centre.***

## 3.2 Mechanical

### 3.2.1 Construction

All electrical components (except the fan in the T808) are mounted on and soldered to a single large PCB. This PCB is mounted onto 2 identical extruded aluminium bars which provide heatsinking for the power semiconductors, as well as mechanical support for the whole power supply. Both front and rear panels are attached to these extrusions. Two identical vented covers on either side of the PCB assembly complete the simple but effective power supply packaging.

The mechanical construction of the T807/808 provides heatsinking, EMI shielding and user protection, and is also designed for ease of servicing and mounting.

### 3.2.2 Disassembly Instructions

**Warning:** Observe the precautions regarding lethal voltages outlined in Section 3.1 of this Manual before disassembling this unit.

#### 3.2.2.1 To Gain Access To The Component Side Of The PCB

This will give access to the fuse, 115V/230V switch or links and the output adjust trim pots.

Remove the 2 guide rail screws at the rear of the right hand cover (top and bottom).

Remove the 8 countersunk screws holding the right hand cover onto the extruded rails (as viewed from the front of the unit).

Remove the right cover.

#### 3.2.2.2 To Gain Access To The Solder Side Of The PCB

Remove the 2 guide rail screws at the rear of the left hand cover (top and bottom).

Remove the 8 countersunk screws holding the left hand cover onto the extruded rails (as viewed from the front of the unit).

Remove the left cover.

### 3.2.3 Reassembly Instructions

Refit the left and right covers in the reverse order to which they were removed.

Ensure that the heat transfer surfaces are clean and add new heatsink compound if necessary.

Power devices Q1, Q2 and D43 must be mounted correctly and electrically isolated from their respective heatsinks (see Section 3.3).

Replace the covers and tighten the screws to the correct torque.

### 3.2.4 Screw Torques

It is important to tighten the cover securing screws to the correct torque to ensure that the T807/808 maintains its specified performance.

We recommend the following torque settings:

Cover Screws	.. 8 - 10lb-in./0.88 - 1.1Nm
PCB To Rails	.. 8 - 10lb-in./0.88 - 1.1Nm
Power MOSFET Transistors (Q1 & Q2)	.. 8 - 10lb-in./0.88 - 1.1Nm
Output Rectifier (D43)	.. 4 - 6lb-in/0.44 - 0.66Nm
Front/Rear Panels and Guide Screws	.. 4 - 5lb-in/0.44 - 0.55Nm



## 3.3 Component Replacement

### 3.3.1 Critical Components

The components in the control loop stabilisation part of the circuit are critical in both value and type. Ensure that only exact equivalents are used for repair.

The components connected to the mains input and/or labelled "X" or "Y" are special components complying with safety regulations and should be replaced only with similarly specified parts to ensure continued safety protection (refer to Section 3.1.5).

### 3.3.2 To Replace The Power Mosfet Transistors (Q1 & Q2)

Remove the transistor clamping bar and devices, taking care **not** to damage the film insulator.

Reassemble the new MOSFET transistors with an undamaged or new thermal film insulator and new thermal compound, using the clamping bar, M3x25 countersunk pozidrive screw and nut.

Ensure that transistors Q1 and Q2 are assembled correctly with adequate thermal compound and are both seated straight and square. Check for unevenness and burrs on the mounting surfaces - the thermal insulator is only 0.05mm (2 mil/0.002") thick so it is very important that the mounting surfaces are clean.

Tighten the screw and nut to the correct torque.

Trim the legs of the transistors and solder.

**Note 1:** Always replace both Q1 and Q2, as well as D14, D15, D18 and D19. Even when only one of the transistors seems to be faulty, it is very likely that both transistors and all 4 diodes are also faulty or damaged.

**Note 2:** After any significant repair work it is recommended that the further fault finding and run-up procedure outlined in Section 6.4 is carried out **before** the unit is reconnected to the mains supply.

### 3.3.3 To Replace The Output Rectifier (D43)

Remove the rectifier, taking care not to damage the insulating gasket.

Attach a new rectifier complete with undamaged or new top hat (T807 only) and thermal film insulator, using the M3x16 countersunk pozidrive screw, spring washer and nut.

D43 is a thermally highly stressed component and incorrect assembly will result in a significant reduction in component life.

Tighten the screw and nut to the correct torque (refer to Section 3.2.2).

Trim the legs of the rectifier and solder.

**Note:** After any significant repair work it is recommended that the further fault finding and run-up procedure outlined in Section 6.4 is carried out **before** the unit is reconnected to the mains supply.

## 3.4 Technical Instructions

From time to time Technical Instructions (TIs) are issued by the Radio Infrastructure Engineering Division of Tait Electronics. These TIs may be used to update equipment or information, or to meet specific operational requirements.

Printed below is a list of TIs applicable to the T807/808. You may wish to file a copy of each TI in this Section for your own reference.

TI No.	Title	Date
358	T807/808 remote sensing of output voltage	10/06/91
365	T807/808 improved earthing for noise interference suppression	29/07/91



## 4 T807/808 Initial Set-up & Adjustment

The following section describes the initial set-up and adjustment procedures.

The following topics are covered in this section.

<b>Section</b>	<b>Title</b>	<b>Page</b>
<b>4.1</b>	<b>Introduction</b>	<b>4.3</b>
<b>4.2</b>	<b>Test Equipment Required</b>	<b>4.3</b>
<b>4.3</b>	<b>Adjustments</b>	<b>4.4</b>
4.3.1	Mains Input Voltage	4.4
4.3.2	Output Voltage Adjustment	4.5
4.3.3	Current Limit Adjustment	4.5
4.3.4	Overvoltage Cut-out Adjustment (Issues 05 & 07 Only)	4.5

<b>Figure</b>	<b>Title</b>	<b>Page</b>
4.1	Test Equipment Set Up	4.4



## 4.1 Introduction



**Warning:** The T807/808 contains voltages that may be lethal and extreme care must be taken when working on a "powered up" supply.



**Caution:** During set-up and adjustment it is essential that the T807/808 is connected to the mains supply via an isolating transformer. For additional protection the test set-up should be powered via an earth leakage circuit breaker.



**Caution:** Connecting test equipment earths to a T807/808 which is not supplied via an isolating transformer will connect the mains supply directly across R3 & D1 and result in the destruction of R3.



**Caution:** While the oscilloscope earth is connected to the DC primary negative rail (TP4), the T807/808 is no longer isolated from the mains earth and neutral. Extreme care is necessary when working on the power supply. Disconnect the oscilloscope immediately after use.

## 4.2 Test Equipment Required

Item	Capability
Earth leakage circuit breaker	10A min., 115 or 230V, trip current <30mA.
Mains isolating transformer	1kVA min.
Variac	1kVA min., 0-260V AC (0-130V AC).
AC current meter	true RMS readings, range to 10A FSD.
AC voltmeter	ranges to 300V FSD.
DC current meter	0-30A FSD.
Variable DC load	0-100 ohm, 20A, 250W for T807
	0-100 ohm, 30A, 400W for T808
*DC power supply	0-18V, 1A
*DC power supply	0-15V, 1A
Oscilloscope	20MHz, general purpose, good quality
*Oscilloscope probes	capable of handling 500V signals

\*Required for Fault Finding only (Section 6).

## 4.3 Adjustments

The T807/808 mains input voltage is factory set to 230V ( $\pm 10\%$ )/50Hz and the output voltage to 13.8V DC. The current limit is adjusted to 16A (T807) or 27A (T808).

When adjusting the output voltage and current limit, set up the test equipment as shown in Figure 4.1.

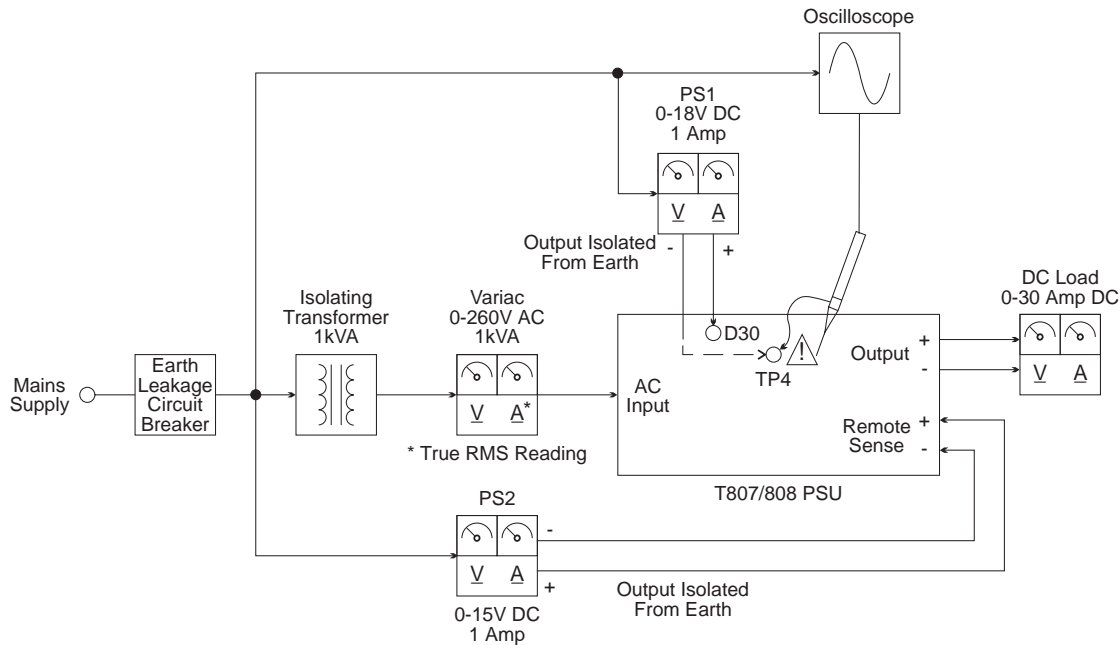

Figure 4.1 Test Equipment Set Up

### 4.3.1 Mains Input Voltage

The mains input voltage can be set to either 230V (200-264V) or 115V (100-135V) by either SW1 or by wire links on the PCB.

Disconnect the mains supply.

Set SW1 (where fitted) to the required input voltage - SW1 can be accessed through the cooling slots on top of the right side cover.

If SW1 is not fitted, remove the left and right side covers (refer to Section 3.2.3).

Change over the PCB links as indicated on the PCB encoding and refit the covers.

Remove or fit the supplied label on the rear panel to **indicate clearly** the mains input voltage to which the unit has been set.



### 4.3.2 Output Voltage Adjustment

Remove the right cover.

Switch the T807/808 on.

Adjust the "V/OUT SET" trim control (RV92) to produce the required output voltage, observing the limits given in Section 1.2.4.

**Note:** Connection of the remote sense terminals after the output voltage has been set will result in a slight change in the nominal output voltage (by approx. 0.3V). The remote sense option should be fitted before setting the output voltage (refer to Section 7.6).

### 4.3.3 Current Limit Adjustment

Turn the "CURRENT LIMIT SET" control (RV25) fully clockwise.

Switch the T807/808 on and set the variable DC load for a current just above the maximum desired current (observing the limits in Section 1.2.4).

Adjust RV25 until the voltage across the DC load just starts to drop.

### 4.3.4 Overvoltage Cut-out Adjustment (Issues 05 & 07 Only)

Set the mains input voltage to 240V (nominal) with a 15A (T807) or 25A (T808) load connected.

Adjust RV92 to give 15V output from the PSU.

Adjust RV81 slowly for power supply cut-out ("On" LED and "Overload" LED will flash on and off).

Reset RV92 to give 13.8V output from the PSU.



## 5 T807/808 Functional Testing

The following test procedures will confirm that the T807/808 has been set up and adjusted correctly and is fully operational.

Refer to Figure 4.1 for test equipment details.

The following topics are covered in this section.

<b>Section</b>	<b>Title</b>	<b>Page</b>
<b>5.1</b>	<b>Basic Operation</b>	<b>5.3</b>
<b>5.2</b>	<b>Undervoltage Lockout &amp; Mains Input Current</b>	<b>5.3</b>
<b>5.3</b>	<b>Output Noise</b>	<b>5.4</b>
<b>5.4</b>	<b>Overall Power Supply Stability</b>	<b>5.4</b>



## 5.1 Basic Operation

To confirm the basic operation of the power supply, proceed as follows.

Set up the test equipment as shown in Figure 4.1.

Ensure the front panel "Power" switch in the **off** position. Connect the T807/808 to the mains supply. The red "Standby" LED should illuminate.

Set the output DC load to maximum resistance/minimum current.

Depress the "Power" switch to turn the T807/808 **on**. The green "On" LED should now illuminate and the red "Standby" LED should extinguish.

Vary the DC load and check that the output voltage and current are within the specifications (refer to Section 1.2.4).

## 5.2 Undervoltage Lockout & Mains Input Current

The figures in brackets [ ] are for 115V/60Hz versions of the T807/808.

Ensure the T807/808 "Power" switch is in the **off** position.

Set up the test equipment (except PS1 & PS2) as shown in Figure 4.1.

Switch on the mains supply and adjust the Variac for 230V or 115V output.

Switch the T807/808 **on** and set the DC load for maximum current (T807/15A; T808/25A).

Slowly reduce the Variac voltage from 230V [115V] until "drop-out" occurs (output current and voltage drop to zero and LED's turn off).

Check that the AC input current and voltage at "drop-out" are as follows:

input current	T807: <2.5A [ $<4A$ ] T808: <4A [ $<6A$ ]
voltage	<185V [ $<95V$ ]

Slowly increase the Variac voltage and check that the supply turns on again at approximately 10V [5V] above "drop-out" voltage.

**Note:** Some on/off oscillation may occur around this voltage point, particularly with a relatively high mains impedance (Variac, mains transformer, etc.) and the power supply load being set to maximum current. Increasing the mains supply by a few volts should turn the supply fully on.

## 5.3 Output Noise

Set up the test equipment (except PS1 & PS2) as shown in Figure 4.1.

Connect a digital voltmeter (e.g. Fluke 77) across the load terminals and set the meter to its lowest AC volts range.

Check that the reading is <10mV AC for both the T807 and T808 under all load and line conditions.

*Note:* A **real** reading of the level of noise present on the output of a switching power supply is very difficult to obtain, as low noise levels, common mode noise paths and ground loops all lead to inaccurate measurement results. The procedure outlined above will, however, give a good indication of the output noise.

## 5.4 Overall Power Supply Stability

Connect the oscilloscope across the output.

Vary the mains voltage and DC load over the full specified range (refer to Section 1.2).

Check on the oscilloscope that no oscillations occur.

Check that no audible noise can be detected, except with open and/or short circuit loading on the output.

## 6 T807/808 Fault Finding

The following test procedures and fault finding flow charts may be used to help locate a hardware problem, however they are by no means a complete fault finding procedure. If the fault still exists after having progressed through them in a logical manner, contact your nearest authorised Tait Dealer or Service Centre. Further assistance may be obtained from the Customer Support Group, Radio Infrastructure Division, Tait Electronics Ltd, Christchurch, New Zealand.

The following topics are covered in this section.

Section	Title	Page
<b>6.1</b>	<b>Visual Checks</b>	<b>6.3</b>
<b>6.2</b>	<b>Component Checks</b>	<b>6.3</b>
6.2.1	General	6.3
6.2.2	Initial Checks	6.4
<b>6.3</b>	<b>Common Faults</b>	<b>6.4</b>
<b>6.4</b>	<b>Further Fault Finding &amp; Run-Up Procedure</b>	<b>6.5</b>
6.4.1	Voltage Control Loop Checks	6.5
6.4.2	Start Up Voltage Checks	6.7
6.4.3	Current Limit Checks	6.8

Figure	Title	Page
6.1	TP6 & TP7 Voltage Waveforms	6.6
6.2	Voltage Waveform Noise Jitter	6.6





## 6.1 Visual Checks

Disconnect the power supply from the mains and wait 5 minutes before removing both covers.

Inspect the PCB for damaged or broken components, paying particular attention to the surface mounted devices (SMD's).

Check for defective solder joints. If repair or replacement is considered necessary, refer to Section 3 of Part A.

Check the fuse. If it is blown, check that the correct rating and type was fitted and fit a new fuse of the correct rating.

**Note:** If the fuse was of a lower rating and there are no signs of component damage, it may be worthwhile fitting a new fuse, replacing the covers and switching the supply on. If the new fuse blows, proceed with fault finding as described in the following sections.

## 6.2 Component Checks

### 6.2.1 General

If a transistor is suspected of faulty operation, an indication of its performance can be assessed by measuring the forward and reverse resistance of the junctions. First make sure that the transistor is not shunted by some circuit resistance (unless the device is completely desoldered). A 20k ohm/V or better multimeter should be used for taking the measurements, using only the medium or low resistance ranges.

The collector current drawn by multijunction transistors is a further guide to their performance.

If an IC is suspect, the most reliable check is to measure the DC operating voltages. Due to the catastrophic nature of most IC failures, the pin voltages will usually be markedly different from the recommended values in the presence of a fault. The recommended values can be obtained from either the circuit diagram or the component data catalogue.

## 6.2.2 Initial Checks

Some components are more likely to be at fault than others and it is recommended that the following are checked first:

<b>D46 (Issue 03)</b>	If short circuited, replace and confirm with a DVM that the impedance on the output terminals is >1k ohm.
<b>Q1 &amp; Q2</b>	Check for shorts between any 2 terminals. If either device is faulty, replace both along with D14, D15, D18 and D19.  Also check R17 and R19 - these will often go faulty along with Q1 or Q2, sometimes with no external indication.
<b>Q1, Q2 &amp; D43</b>	Check and confirm that they are isolated from their respective heat-sinks.
<b>R2 &amp; R49</b>	Check their resistance is >1M ohm.
<b>R3</b>	Check and replace if the resistance is >15 ohms.
<b>IC2</b>	Check by applying 20V DC across C37 and measuring for 15V at TP5. If no voltage is present at TP5, measure at IC2 pin 3. If there is still no voltage, replace IC2. If 15V is present, check TC1 connections. Replace if in doubt.
<b>VREF</b>	Check VREF is 5.1V +_1%.

## 6.3 Common Faults

Switch the T807/808 off, and then on, and check for the following faults:

Symptoms	Possible Causes
No LED's light up No output	no mains supply low mains supply voltage* thermal cut-out has operated (equipment has overheated)* fuse blown defective switching circuitry
On standby red "Standby" LED lights up, but no output and no LED's light up when power switch set to <i>on</i>	defective switching circuitry
Red "Standby" LED lights up Green "on" LED lights up but no output when power switch set to <i>on</i>	short circuit across output overvoltage protection diode has gone short circuit# defective power supply output section

\*The fan in the T808 will continue to run.

#Issue 03 only.

## 6.4 Further Fault Finding & Run-up Procedure



**Warning:** The T807/808 is not a conventional power supply and the potential for lethal accidents is very real. It is imperative that the following procedures are followed precisely and under no circumstances must any short cuts be taken. These procedures have been carefully designed to minimise the danger to service personnel and deviation from them will only compromise the safety of all concerned. Wear safety goggles while running up or working in close proximity to the T807/808.

Because of the dangers involving off-line power supplies, it is suggested that the following procedures are followed, both after repairs have been carried out and for further fault finding. These procedures should be carried out only by suitably qualified personnel.

Refer to Figure 4.1 for test equipment details, ***paying particular attention to the cautions listed in Chapter 4.1.***

**Note:** The figures in brackets [ ] refer to 115V/60Hz versions of the T807/808.

### 6.4.1 Voltage Control Loop Checks

Ensure that the mains input supply is disconnected from the T807/808 (hereafter referred to as the "PSU") and the "Power" switch is set to ***off***.

Apply 15V from an external power supply (PS1) to the anode of D30 (+) and TP4 (-).

Check that the red "Standby" LED is ***on***.

Check ***on the T808*** that the fan is running.

Switch the PSU on and check that it does not draw excessive current (<400mA) from PS1.

The red "Standby" LED should turn ***off***.

Check that the voltage on pin 1 of IC3 is <0.5V.

If the voltage is high (approximately 15V), momentarily increase the PS1 voltage to 18V and then reduce it to 15V. If the voltage at pin 1 is still high, check for circuit faults.

Using an oscilloscope with the probe ground connected to TP4, check the voltage waveform at TP6 and TP7 is as shown in Figure 6.1.

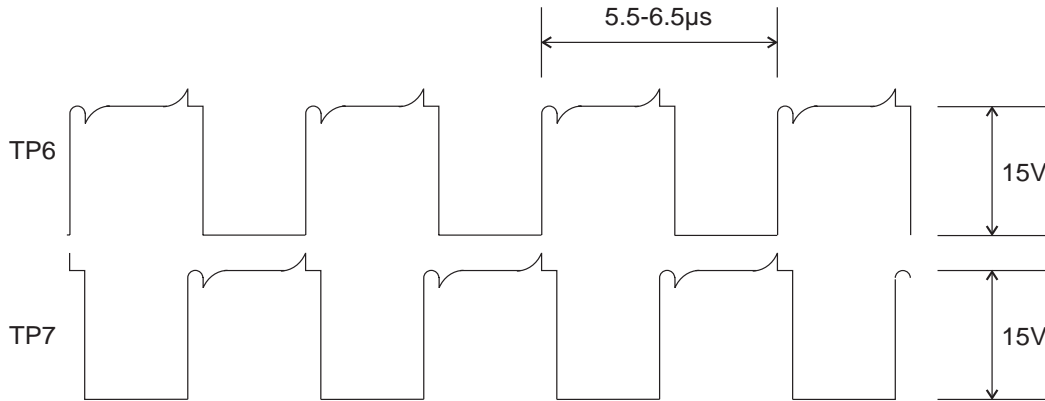

Figure 6.1 TP6 & TP7 Voltage Waveforms

**Note:** Voltage spikes on the above waveforms are shown for a T807. These spikes appear with larger magnitude on a T808.

Switch the PSU off and on, confirming that the waveform's duty cycle starts at 0 and slowly increases to 50%.

Check that after a short delay (approx. 0.25 seconds), the waveform shows signs of noise jitter (refer to Figure 6.2). This jitter indicates that the noise modulator is operating satisfactorily.

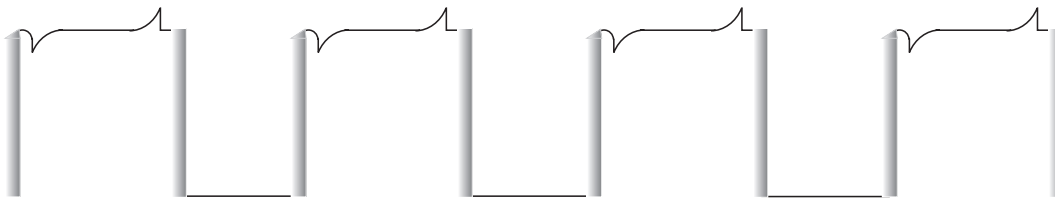

Figure 6.2 Voltage Waveform Noise Jitter

Connect a second variable power supply (PS2) to the **remote sense** terminals of the PSU.

**Note:** **Issues 05 & 07 Only.** Turn RV81 fully clockwise.

Turn RV92 fully clockwise and, whilst observing the waveform at TP6 or TP7, slowly increase the voltage.

Check that at approximately 10-11V the waveform suddenly reduces in duty cycle and disappears altogether.

Turn RV92 anticlockwise and check that the waveform reappears.

Turn RV92 fully anticlockwise and increase the voltage until the waveform disappears. At this point the voltage should not exceed 16.5V. Reducing the voltage should always make the waveform reappear.

Turn RV92 fully clockwise.

This confirms the basic operation of the voltage control loop. Remove the second variable power supply from the PSU remote sense terminals and disconnect the oscilloscope (refer to Note 1 on page 6.5).

#### 6.4.2 Start Up Voltage Checks

Ensure the switch (or link) is set to the correct mains voltage.

Turn RV25 fully clockwise.

Connect the Variac output (set to minimum output voltage) to the PSU AC input socket.

Increase the Variac output slowly whilst monitoring the AC current which should remain low at this point.

Continue increasing the voltage to approximately 60V AC [30V AC].

Check that approximately 3V is now present at the PSU output and that the "On" LED is glowing.

Check with a multimeter that the DC voltage between TP1 and TP4 is approximately 80V and between TP2 and TP4 is half of that figure  $\pm 5V$ .

**Note:** If the voltage difference is outside tolerance, disconnect the Variac from the PSU, **wait for the voltages to drain away**, and inspect the circuitry for the cause.

**Warning:** **Do not proceed until the cause is found, rectified and satisfactory results obtained.**  
**High voltages and therefore high energies exist on C9-C12 that can result in spectacular if not harmful explosions of the capacitors and/or transistors (Q1 & Q2).**

Increase the AC input and check that RLY1 activates at approximately 8V output. If the relay has not activated at 9V, investigate and rectify before proceeding.

**Note:** To prevent R3 overheating, it is essential to check that RLY1 has activated **before** proceeding any further.

Connect a variable DC load to the PSU output and monitor the output current.

Increase the load and check that the current limits to approximately 10A (T807) or 17A (T808).

Adjust RV25 to observe the operation of the current limit circuitry.

Return RV25 to the fully clockwise position and remove the load.

Increase the AC voltage and check that at approximately 120V AC [60V AC] the PSU output voltage stabilises at approximately 10V DC.

Check with a multimeter that the DC voltage between TP1 and TP4 is approximately 160V and between TP2 and TP4 is half of that figure  $\pm 5V$ .

**Note:** If the voltage difference is outside tolerance, disconnect the Variac from the PSU, **wait for the voltages to drain away**, and inspect the circuitry for the cause.

Continue increasing the AC voltage.

Check that at approximately 180V AC [90V AC] the current supplied by the external 15V supply (PS1) begins to reduce as the internal supply starts taking over.

Continue increasing the voltage to 200V AC [100V AC] and disconnect the external power supply.

Check that the PSU continues to function normally. If not, check the components associated with T4.

Fit the top cover loosely in place.

### 6.4.3 Current Limit Checks

Apply a load of approximately 1A to the output terminals.

Check that the AC input current is within acceptable limits.

Increase the current through the load and check that the current limit is still functioning.

Adjust the current limit for 16A (+0, -0.5A) in the T807, or 27A (+0, -1A) in the T808.

**Note:** **Issues 05 & 07 Only.**

Check "Overload" LED illuminates when the load is increased to current limit set point  $-0.5A \pm 0.5A$ .

Adjust load current to 15A (T807) or 25A (T808).

Adjust RV92 for 15V DC output.

Slowly adjust RV81 so that the power supply just trips out. The "On" LED and "Overload" LED will flash on and off.

Reduce the current through the load to 1A and adjust RV92 for 13.8V output.

Check the current limit again and adjust slightly if necessary.

Check also that the short circuit current limit is functioning.

Check that the AC current is within limits at full output and run the PSU for a few minutes at 200-260V AC (230V typical) [100-130V AC (115V typical)].

Switch off, disconnect from the mains and inspect for any signs of overheating.

Reassemble as described in Section 3.2.4.

This completes the run-up and fault finding of the T807/808.





## 7 T807/808 Installation

The following section gives a brief description of the basic rack mounting and wiring procedures.

The following topics are covered in this section.

Section	Title	Page
<b>7.1</b>	<b>General</b>	<b>7.3</b>
<b>7.2</b>	<b>Rack Mounting</b>	<b>7.3</b>
<b>7.3</b>	<b>Rack Frame Earthing</b>	<b>7.3</b>
<b>7.4</b>	<b>Noise Interference Suppression Earthing</b>	<b>7.4</b>
7.4.1	Introduction	7.4
7.4.2	Mounting	7.4
7.4.3	Earthing	7.4
7.4.4	Filtering	7.5
<b>7.5</b>	<b>Float Charging a Battery</b>	<b>7.5</b>
<b>7.6</b>	<b>Output Voltage Remote Sensing</b>	<b>7.6</b>
<b>7.7</b>	<b>Parallel Operation</b>	<b>7.8</b>
<b>7.8</b>	<b>Mains And/Or Power Supply Failure Alarm</b>	<b>7.8</b>

Figure	Title	Page
7.1	Output Voltage Remote Sensing	7.6
7.2	±1% Constant Output Voltage By "Local Sensing"	7.6
7.3	Output Voltage Remote Sensing With Fuse And/Or Switch	7.7



## 7.1 General

The DC output wiring must be of sufficient gauge to carry the current required without excessive voltage drops, i.e. <0.5V in total, even with remote sensing connected. The minimum recommended wire sizes are as follows:

T807 (15A rated output current):	2.0mm (e.g. 152/153 auto cable)
T808 (25A rated output current):	3.0mm (e.g. 154/155 auto cable), or 2 runs of 2.0mm cable

Use only an IEC type connector for normal mains input wiring and ensure that this wiring has a current rating of at least 5A for the T807 and 10A for the T808.

The output is factory set to 13.8V (no remote sense connected; refer to Section 4.3.2) and the current limit set to 16A for the T807 and 25A for the T808. Refer to Section 4.3.3 if it is necessary to change these values.

## 7.2 Rack Mounting

The T807/808 is designed for use in a standard 483mm rack frame using the supporting guide rails supplied with the units. **Do not** install this unit with any other type of guide rail, as this may prevent adequate ventilation through and past the unit.

The lower guide rail is located in the rack frame with three screws, two at the rear and one at the front. The short upper guide rail is located with just one screw. The unit is secured into the guide with two front panel mounting screws.

Although the T807/808 is a high efficiency switching power supply, a considerable amount of heat is generated during normal operation. An adequate flow of cooling air is therefore essential for reliable operation. **Do not** operate this unit in a completely enclosed cabinet.

If continuous operation at high ambient temperatures is necessary, forced air cooling is recommended for additional reliability. It is estimated that the average life expectancy of this unit will double with every 10°C drop in ambient temperature.

## 7.3 Rack Frame Earthing

The power supply case is internally connected to mains earth. Because the unit's case and the rack frame in which it is usually installed are painted, a secure electrical earthing connection between the unit and the rack is **not** guaranteed (i.e. it is reliant on breaking through the paint coating).

It is therefore strongly advised that an additional and secure electrical connection is provided by means of the supplied earth lead (see below). Failure to do so may result in harmful voltage potentials between the power supply and rack frame, and/or miscellaneous power supply switching noise problems in both receivers and transmitters.

Fit the "push-on" connector on one end of the earthing cable onto the earthing tab at the rear of the power supply.

Fit the slotted spade connector on the other end of the cable under a conveniently located screw on the rack frame. Ensure by testing continuity that a secure electrical and mechanical connection is achieved.

Alternatively, the slotted spade connector can be cut off and the earth wire fitted to a -DC rail terminal, either on the rear of the power supply or on a -DC rail (0V) terminal nearby. This should be done only if a mechanically and electrically secure connection between -DC rail and the rack frame is installed as part of the system.

## 7.4 Noise Interference Suppression Earthing

### 7.4.1 Introduction

The problem of noise interference may occur in installations which include T300 series receivers and T807/808 power supplies. The procedures outlined in the following Sections will minimise the possibility of noise interference from three main sources:

- noise directly picked up via the aerial system if the receive aerial is within approximately 3 metres of the power supply;

- noise directly radiated into the receiver;

- noise carried via the 13.8V line to the receiver.

These procedures should also be followed to ensure that both the individual units and the rack frame are earthed to mains earth for reasons of mains safety.

### 7.4.2 Mounting

The T807/808 should be mounted as far as possible from the receiver, i.e. in a typical repeater system there should be a transmitter, duplexer and speaker panel between the power supply and the receiver. Mount the aerial at least 3m from the T807/808.

### 7.4.3 Earthing

Ensure that all the individual units (receiver, transmitter, power supply) are earthed to the front of the rack via the front panel and the rear of the rack frame via a separate earthing strap.

T807/808 power supplies already have the front panel earthed to the chassis. On other units, a small amount of paint may need to be removed from the back of the front panel

around the button head screws to ensure a good earthing contact. The upper and lower M3 x 8mm front panel mounting screws require M3 internal shakeproof washers (IPN 353-00010-13) to break through the paint and earth the front panel to the rack.

T807/808's manufactured after June 1991 have an earth terminal at the rear of the unit which should be connected securely to earth. Other units will require a strap from the chassis earth to the rack in the immediate vicinity of the unit. This can be done via the negative rail for each unit.

#### 7.4.4 Filtering

The 13.8V supply to the receiver can be filtered to prevent noise entering and desensitising the receiver.

Fit one Tait No. 8 inductor (IPN 056-00010-08) in the positive lead and one in the negative lead.

**Note:** Fit the inductors to the receiver supply leads only. The maximum current handling capability of the No. 8 inductor is less than the T807/808 maximum output current.

### 7.5 Float Charging A Battery

The T807/808 power supply can be used to float charge a 12V battery under constant voltage conditions (e.g. a conventional lead acid battery). The current limit circuit will prevent the charging current from becoming excessive if the battery connected is completely discharged.

For short circuit and reverse polarity protection, it is essential that a fuse of suitable rating (15A in T807 and 25A in T808) is inserted in the battery line.

**Issue 05 & 07.** The T807/808 contains an internal rectifier diode (**D43**) which will protect the power supply by blowing the fuse if a battery is accidentally connected in reverse.

**Issue 03.** The T807/808 contains a 16V transient suppression diode (**D46**) across the output which will protect the power supply by blowing the fuse if a battery is accidentally connected in reverse.

A series charging diode is not required to isolate the battery from the power supply in the case of mains failure, as the reverse discharge current back into the supply is <5mA.

**Note:** The T807/808 does not compensate for the temperature dependence of lead acid batteries. The output voltage will need to be adjusted to suit the battery and ambient temperature.

## 7.6 Output Voltage Remote Sensing

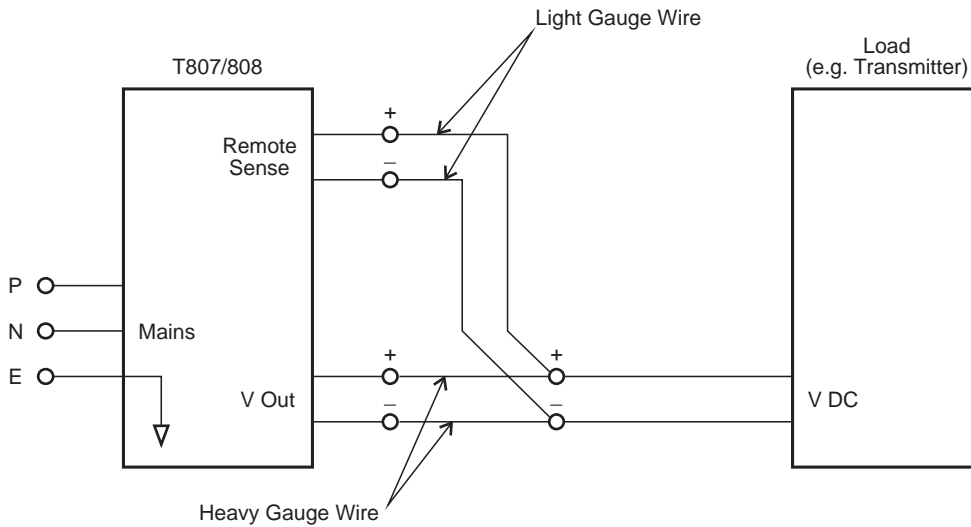

Figure 7.1 Output Voltage Remote Sensing

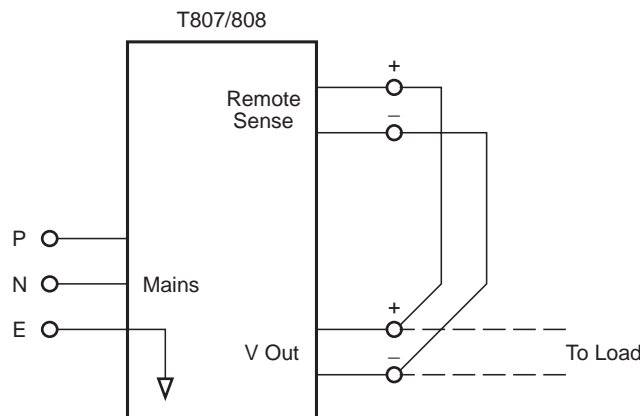

Figure 7.2 ±1% Constant Output Voltage By "Local Sensing"

To maintain the supply voltage within a tolerance of  $\pm 1\%$  at the load terminals (e.g. transmitter), remote sensing is provided on 2 extra screw terminals at the rear of the T807/808.

To keep power dissipation in the supply output wiring **and** the power supply to a minimum, it is recommended that the output wiring is of sufficient gauge to limit the voltage difference between  $V_{out}$  and  $V_{DC}$  to a maximum of 0.5V (refer to Figure 7.1).

**Note:** *Issue 05 & 07 Only.* The overvoltage protection pot RV81 may need to be readjusted if maximum current is drawn and long leads are used to the voltage sense points.

To maintain the voltage within a tolerance of  $\pm 1\%$  at the power supply output terminals, it is recommended that the remote sense terminals are connected directly to the output

terminals (refer to Figure 7.2).

**Note 1:** Ensure that the remote sense connections are made with the correct polarity (i.e. "+" to "+" and "-" to "-") before the mains supply is connected. Shorting of the remote sense connections on a running supply **before** they are connected to the output wiring will result in the destruction of the T807/808 overvoltage diode, D46 (refer to Note 4 below).

**Note 2:** As the output voltage is factory set to 13.8V with **unconnected** remote sense terminals, connection of these terminals will result in a slight change in the nominal output voltage (i.e. from 13.8V to approximately 13.5V). If required, the nominal output voltage can be readjusted (refer to Section 4.3.2).

**Note 3:** When remote sensing and float charging are set up as part of a system, it is recommended that the actual battery charging voltage is close to 13.8V (or its temperature compensated equivalent). Voltages above or below the nominal float charge value will mean either the battery is overcharged (high voltage) or never fully charged (low voltage).

**Note 4:** When a fuse and/or switch is fitted in the output wiring between the power supply and the load, it is essential that the remote sensing is connected to the **power supply side** of the switch or fuse, as shown in Figure 7.3.

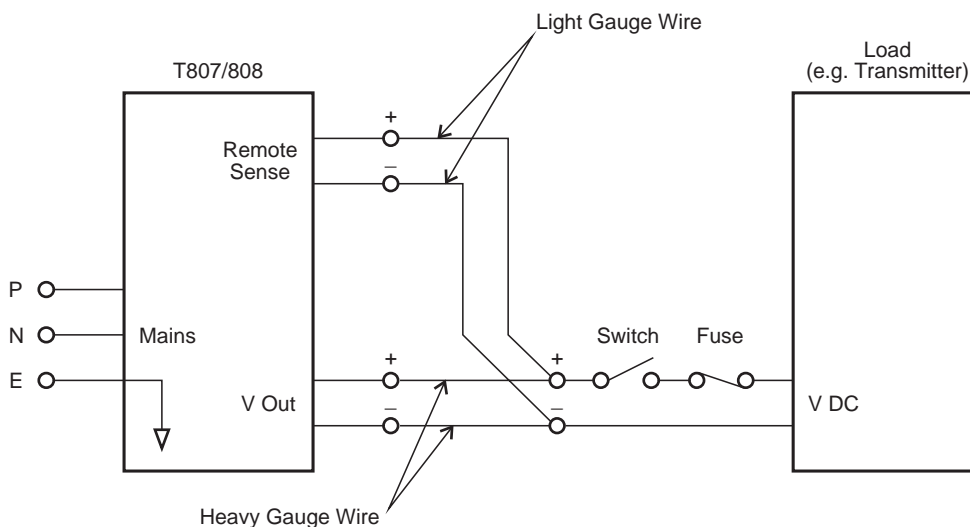

**Figure 7.3** Output Voltage Remote Sensing With Fuse And/Or Switch

Failure to do this will result in the destruction of the main rectifier diode D43 (**Issues 05 & 07**) or the overvoltage diode D46 (**Issue 03**), in the T807/808 when the fuse or switch is open. This happens when the power supply "sees" 0 volts across the remote sense terminals and the output voltage is then increased to compensate for the apparent reduction of output voltage.

## 7.7 Parallel Operation

T807/808 power supplies may be operated in parallel as follows:

Set the output voltages to within 0.1V of each other.

Connect the supplies together with equal lengths of output wire.

**Note:** With very light or no load, only one power supply may have its "On" LED illuminated. This is normal and the LED's on the other supplies will illuminate as soon as the load is increased.

## 7.8 Mains And/or Power Supply Failure Alarm

A mains and/or power supply failure alarm output signal (to -DC rail/0V) is available on the T807/808 rear panel for system monitoring purposes.

Mains & power supply OK: approx. +Vout (via 1k resistor - typ. 13.8V)

Mains &/or power supply failure: approx. -Vout (via 11k resistors - typ. 0V)  
(with or without a battery across  
main DC output)

This alarm output can be directly connected to an optocoupler input of a T802 remote monitor unit.



## 8 T807/808 PCB Information

This section provides parts lists, exploded views of the mechanical assemblies, grid reference indices, PCB layouts and circuit diagrams for three distinct issues (-03, -05 and -07) of the T807/808 Switching Power Supplies. There is also a parts list, PCB layout and circuit diagram for the Noise Modulator PCB which solders onto TP4 of the issue -03 Power Supply PCB. The noise modulation circuit was incorporated into all Power Supply PCBs from issue -05 onwards.

The T807 and T808 are built on a common main PCB, though certain components have different values. While we have provided individual parts lists for each product, all other information provided in this section pertains to both products, with the different value components clearly indicated with an asterisk.

This section contains the following information.

Section	Title	IPN	Page
<b>8.1</b>	<b>Introduction</b>		<b>8.1.3</b>
<b>8.2</b>	<b>T807/808 Switching Power Supply PCB</b>	<b>220-01183-03</b>	<b>8.2.1</b>
	<b>T807/808 Noise Modulator PCB</b>	<b>220-01268-00</b>	<b>8.2.21</b>
	<b>T807/808 Switching Power Supply PCB</b>	<b>220-01183-05</b>	<b>8.2.25</b>
	<b>T807/808 Switching Power Supply PCB</b>	<b>220-01183-07</b>	<b>8.2.43</b>



## 8.1 Introduction

### PCB Identification

All PCBs are identified by a unique 10 digit number, the last 2 digits of which define the issue status. The issue status starts at 00 and increments through 01, 02, 03, etc. as the PCB is updated. Some issue PCBs never reach full production status and are therefore not included in this manual. A letter following the 10 digit IPN has no relevance in identifying the PCB for service purposes.

### Parts Lists

The 10 digit numbers (000-00000-00) in this Parts List are “internal part numbers” (IPNs). Your spare parts orders can be handled more efficiently if you quote the IPN and provide a brief description of the part.

The components listed in this parts list are divided into two main types: those with a circuit reference (e.g. C2, D1, R121, etc.) and those without (miscellaneous and mechanical).

Those with a circuit reference are grouped in alphabetical order and then in numerical order within each group. Each component entry comprises three or four columns, as shown below:

Ref	Var	IPN	Description
C126		015-06100-08	CAP CER 1206 CHIP 100N 10% X7R 50V
C127		020-09220-01	CAP ELECT RADL 220M 16V 10X12.5MM
C128		015-06100-08	CAP CER 1206 CHIP 100N 10% X7R 50V
C129		015-06100-08	CAP CER 1206 CHIP 100N 10% X7R 50V
&C130	10	015-25100-08	CAP CER 0805 CHIP 10N 10% X7R 50V
&C130	15	015-24470-08	CAP CER 0805 CHIP 4N7 10% X7R 50V
&C130	20	015-25100-08	CAP CER 0805 CHIP 10N 10% X7R 50V
&C130	25	015-24470-08	CAP CER 0805 CHIP 4N7 10% X7R 50V
C131		015-24100-08	CAP CER 0805 CHIP 1N 10% X7R 50V
C132		015-24470-08	CAP CER 0805 CHIP 4N7 10% X7R 50V
C133		015-05470-08	CAP CER 1206 CHIP 47N 10% X7R 50V

circuit reference - lists components in numerical order  
 variant column - indicates that this component is fitted only to this variant  
 description - gives a brief description of the component  
 Internal Part Number - order the component by this number

The miscellaneous and mechanical section lists the variant and common parts in IPN order.

## Grid Reference Index

To assist in locating components and labelled pads on the PCB layouts and circuit diagrams, a component grid reference index has been provided. This index lists the components and pads in alphabetical order, along with the appropriate alphanumeric grid references, as shown below:

Device	PCB	Circuit
C126	2:A6	2-R7
C127	1:A8	2-P4
C128	2:B7	2-P2
C129	2:C12	2-E3
&C130	2:D8	2-B8
C131	2:C9	2-H6
C132	2:D8	2-B8
C133	2:D6	2-E1

components listed in alphanumeric order

PCB layout reference  
circuit diagram reference

component location on the sheet

sheet number

component location on the layer

layer number -  
1 = top side layer  
2 = bottom side layer

## Using CAD Circuit Diagrams

Reading a CAD circuit diagram is similar to reading a road map, in that both have an alphanumeric border. The circuit diagrams in this manual use letters to represent the horizontal axis, and numbers for the vertical axis. These circuit diagram “grid references” are useful in following a circuit that is spread over two or more sheets.

When a line representing part of the circuitry is discontinued, a reference will be given at the end of the line to indicate where the rest of the circuitry is located. The first digit refers to the sheet number (printed on the bottom right hand corner of the CAD diagram) and the last two characters refer to the location on that sheet of the continuation of the circuit (e.g. 1-D4).

If more than one line is represented (indicated by a double thickness line), a dot with a reference label will follow the route each individual line represents.

## 8.2 T807/808 Power Supply PCB

This section contains the following information.

IPN	Section	Page
<b>220-01183-03</b>	T807 Parts List	8.2.3
	T807 Mechanical & Miscellaneous Parts	8.2.6
	T807 Mechanical Assembly Exploded View	8.2.7
	T808 Parts List	8.2.9
	T808 Mechanical & Miscellaneous Parts	8.2.12
	T808 Mechanical Assembly Exploded View	8.2.13
	T807/808 Grid Reference Index	8.2.15
	T807/808 PCB Layout - Bottom Side	8.2.17
	T807/808 PCB Layout - Top Side	8.2.18
	T807/808 Circuit Diagram	8.2.19
<b>220-01268-00</b>	T807/808 Noise Modulator Parts List	8.2.21
	T807/808 Noise Modulator PCB Layout	8.2.22
	T807/808 Noise Modulator Circuit Diagram	8.2.23
<b>220-01183-05</b>	T807 Parts List	8.2.25
	T807 Mechanical & Miscellaneous Parts	8.2.28
	T807 Mechanical Assembly Exploded View	8.2.29
	T808 Parts List	8.2.31
	T808 Mechanical & Miscellaneous Parts	8.2.34
	T808 Mechanical Assembly Exploded View	8.2.35
	T807/808 Grid Reference Index	8.2.37
	T807/808 PCB Layout - Bottom Side	8.2.39
	T807/808 PCB Layout - Top Side	8.2.40
	T807/808 Circuit Diagram	8.2.41
<b>220-01183-07</b>	T807 Parts List	8.2.43
	T807 Mechanical & Miscellaneous Parts	8.2.46
	T807 Mechanical Assembly Exploded View	8.2.47
	T808 Parts List	8.2.49
	T808 Mechanical & Miscellaneous Parts	8.2.52
	T808 Mechanical Assembly Exploded View	8.2.53
	T807/808 Grid Reference Index	8.2.55
	T807/808 PCB Layout - Bottom Side	8.2.57
	T807/808 PCB Layout - Top Side	8.2.58
	T807/808 Circuit Diagram	8.2.59



## T807 Parts List (IPN 220-01183-03)

### How To Use This Parts List

The components listed in this parts list are divided into two main types: those with a circuit reference (e.g. C2, D1, R121, etc) and those without (miscellaneous and mechanical). Static sensitive devices are prefixed with (S).

Those with a circuit reference are grouped by component type in numerical order. Each component entry comprises three or four columns: the circuit reference, variant number (if applicable), IPN and description. A number in the variant column indicates that this component is fitted only to that variant.

The miscellaneous and mechanical section lists the parts in IPN order and where possible the legend indicates their position on the exploded view.

### Parts List Amendments

R13A Changed from 10E to 68E (94/06-301).  
 R93 Changed from 1K to 910E (94/06-301).  
 R1 & R85 Changed from 030-08100-30 to 030-08100-31 due to incorrect voltage rating of the original (93/07-348).  
 R1 & R85 10M added to underside of PCB to meet BABT high voltage requirements (93/04-202).  
 D43 Changed from MBR20100 (001-00011-44) to 30CPQ90 to meet BABT high voltage requirements (93/04-202).  
 FC1 & FC2 (Fuseholders) changed from 6.3mm (340-00010-06) to 5mm, due to being the wrong size (93/04-181).  
 C23 Changed from 020-08470-07 to -09 due to high profile of the original (92/10-742).

Important mechanical assembly changes to this issue are as follows:

Sidecover Changed from 303-23128-00 to -01. Width increased by 0.5mm to pass BABT high voltage test (94/05-243).  
 Spacer Changed from 319-30030-00 to -01. Length increased by 0.5mm to pass BABT high voltage test (94/05-243).  
 Screw 4-40 1/4" Changed from 349-00020-06 to -07 (5/16") due to obsolete component (93/08-410).  
 Gasket 362-00010-07 replaced by insulator 54\*30 (362-01024-00) to meet BABT high voltage requirements (93/04-202).

Ref	Var	IPN	Description	Ref	Var	IPN	Description
C1		010-04220-09	CAP CER 2N2 10% 250VAC APPROVED	C60		017-15470-01	CAP CER SURFACE BARRIER 47N 20% 50V
C2		010-04220-09	CAP CER 2N2 10% 250VAC APPROVED	C61		025-08100-03	CAP 10M 35V 20% TANT 5MM L/S
C3		022-06470-04	CAP MYLAR 470N 10% 250VAC	C62		019-05470-00	CAP MONOLITHIC CER 47N 10% 50V X7R
C4		022-06470-04	CAP MYLAR 470N 10% 250VAC	C63		022-57100-02	CAP MYLAR AI 1M 20% 50V POTTED
C5		012-04220-06	CAP CER 2N2 3-PIN SUPPR FLTR	C65		020-09470-07	CAP 470M 16V 20% ELEC VERT 8*20 3.5MM L/S LO-ESR
C6		012-04220-06	CAP CER 2N2 3-PIN SUPPR FLTR	C66		024-14470-01	CAP METAL POLYPR RADL 4N7 10% 400VAC
*C9		021-09390-00	CAP 390UF ELECT 200V 105D 25DIA X40 10MMLS	C67		024-14470-01	CAP METAL POLYPR RADL 4N7 10% 400VAC
*C10		021-09390-00	CAP 390UF ELECT 200V 105D 25DIA X40 10MMLS	*C68		020-19220-02	CAP ELECT RAD 2200M 16V 12.5X30MM LO ESR
*C11		021-09390-00	CAP 390UF ELECT 200V 105D 25DIA X40 10MMLS	*C69		020-19220-02	CAP ELECT RAD 2200M 16V 12.5X30MM LO ESR
*C12		021-09390-00	CAP 390UF ELECT 200V 105D 25DIA X40 10MMLS	*C70		020-19220-02	CAP ELECT RAD 2200M 16V 12.5X30MM LO ESR
*C13		024-06680-08	CAP POLYPR AXIAL 680N 20% 250VDC	*C71		020-19220-02	CAP ELECT RAD 2200M 16V 12.5X30MM LO ESR
*C14		024-06680-08	CAP POLYPR AXIAL 680N 20% 250VDC	*C72		020-19220-02	CAP ELECT RAD 2200M 16V 12.5X30MM LO ESR
*C15		010-03220-03	CAP CER 220P 10% T/C B 6KV	*C73		020-19220-02	CAP ELECT RAD 2200M 16V 12.5X30MM LO ESR
C16		025-07100-01	CAP TANT BEAD 1M 35V	C74		010-04220-09	CAP CER 2N2 10% 250VAC APPROVED
C17		011-53470-02	CAP CER AI 470P 10% T/C B 63V	C75		010-04220-09	CAP CER 2N2 10% 250VAC APPROVED
C20		010-04100-04	CAP CER 1N 10% T/C B 400V	C78		020-09820-01	CAP 820M 16V ELECT 10X25MM
C21		022-55470-10	CAP MYLAR AI 47N 5% 63V POTTED	C79		019-05470-00	CAP MONOLITHIC CER 47N 10% 50V X7R
C22		022-55470-10	CAP MYLAR AI 47N 5% 63V POTTED	C80		010-04100-04	CAP CER 1N 10% T/C B 400V
C23		020-08470-09	CAP ELECT RADL 47M 16V 10X18MM HI TEMP	C81		010-04100-04	CAP CER 1N 10% T/C B 400V
C24		020-07100-04	CAP ELECT RADL 1M 63V 8X12MM HI TEMP	C82		010-04100-04	CAP CER 1N 10% T/C B 400V
C25		025-08100-03	CAP 10M 35V 20% TANT 5MM L/S	C84		019-05470-00	CAP MONOLITHIC CER 47N 10% 50V X7R
C26		011-54100-01	CAP CER AI 1N 10% T/C B 63V	C85		011-52330-01	CAP CER AI 33P 5% N150 50/63V
C27		011-54100-01	CAP CER AI 1N 10% T/C B 63V	C86		022-54100-10	CAP MYLAR AI 1N 5% 63V POTTED
C31		011-54100-01	CAP CER AI 1N 10% T/C B 63V	C87		022-54220-10	CAP MYLAR AI 2N2 5% 63V POTTED
C32		011-54100-01	CAP CER AI 1N 10% T/C B 63V	C88		022-55470-10	CAP MYLAR AI 47N 5% 63V POTTED
C33		019-05470-00	CAP MONOLITHIC CER 47N 10% 50V X7R	C89		011-52220-01	CAP CER AI 22P 5% N150 50/63V
C34		025-08100-03	CAP 10M 35V 20% TANT 5MM L/S	C90		010-04100-04	CAP CER 1N 10% T/C B 400V
C37		020-19220-04	CAP 2200M ELEC 35V 16X35 L ESR	C91		010-04100-04	CAP CER 1N 10% T/C B 400V
C38		019-05470-00	CAP MONOLITHIC CER 47N 10% 50V X7R	C95		011-54100-01	CAP CER AI 1N 10% T/C B 63V
C39		019-05470-00	CAP MONOLITHIC CER 47N 10% 50V X7R	D1		001-00012-30	(S) DIODE 6A6 MR 756 BY214-600 6A/600V
C42		011-54100-01	CAP CER AI 1N 10% T/C B 63V	D2		001-00012-30	(S) DIODE 6A6 MR 756 BY214-600 6A/600V
C43		011-54100-01	CAP CER AI 1N 10% T/C B 63V	D3		001-00012-30	(S) DIODE 6A6 MR 756 BY214-600 6A/600V
C44		025-07100-01	CAP TANT BEAD 1M 35V	D4		001-00012-30	(S) DIODE 6A6 MR 756 BY214-600 6A/600V
C45		011-54100-01	CAP CER AI 1N 10% T/C B 63V	D5		001-50012-05	(S) DIODE AI 1N4531 SI SMALL SIG
C46		011-54100-01	CAP CER AI 1N 10% T/C B 63V	D6		001-50012-05	(S) DIODE AI 1N4531 SI SMALL SIG
C49		019-05470-00	CAP MONOLITHIC CER 47N 10% 50V X7R	D7		001-50012-05	(S) DIODE AI 1N4531 SI SMALL SIG
C50		025-08100-03	CAP 10M 35V 20% TANT 5MM L/S	D8		001-50012-05	(S) DIODE AI 1N4531 SI SMALL SIG
C51		010-04100-04	CAP CER 1N 10% T/C B 400V	D11		001-50012-05	(S) DIODE AI 1N4531 SI SMALL SIG
C54		011-54100-01	CAP CER AI 1N 10% T/C B 63V	D12		001-50012-05	(S) DIODE AI 1N4531 SI SMALL SIG
C55		019-05470-00	CAP MONOLITHIC CER 47N 10% 50V X7R	D13		008-00014-73	(S) LED HLMP5050 GREEN RT ANGLE PCB MTG
C56		025-08100-03	CAP 10M 35V 20% TANT 5MM L/S	D14		001-00012-23	(S) DIODE BYV26C 1A/400V FAST SWITCH
C57		025-08100-03	CAP 10M 35V 20% TANT 5MM L/S				
C59		011-54100-01	CAP CER AI 1N 10% T/C B 63V				

Ref	Var	IPN	Description	Ref	Var	IPN	Description
*D15		001-00012-27	(S) DIODE BYV28-200 3.5A/200V FAST SWITCH	R53		030-55330-20	RES FILM AI 33K 5% 0.4W 4X1.6MM
*D18		001-00012-27	(S) DIODE BYV28-200 3.5A/200V FAST SWITCH	R54B		030-55330-20	RES FILM AI 33K 5% 0.4W 4X1.6MM
D19		001-00012-23	(S) DIODE BYV26C 1A/400V FAST SWITCH	R55		045-05100-01	RES NTC 10K 5% 5MM DISC
D20		001-50012-05	(S) DIODE AI 1N4531 SI SMALL SIG	R56		030-55100-20	RES FILM AI 10K 5% 0.4W 4X1.6MM
D21		001-50012-05	(S) DIODE AI 1N4531 SI SMALL SIG	R57		030-55270-20	RES FILM AI 27K 5% 0.4W 4X1.6MM
D22		001-00013-40	(S) DIODE SCHOTTKY BAT85 0.2A/30V	R58		030-55100-20	RES FILM AI 10K 5% 0.4W 4X1.6MM
D24		001-00011-70	(S) DIODE 1N4001 1A/50V	R59		030-57100-20	RES FILM AI 1M 5% 0.4W 4X1.6MM
D25		001-00011-70	(S) DIODE 1N4001 1A/50V	R62		030-54680-20	RES FILM AI 6K8 5% 0.4W 4X1.6MM
D26		001-00011-70	(S) DIODE 1N4001 1A/50V	R63		030-52330-20	RES FILM AI 33E 5% 0.4W 4X1.6MM
D27		001-00011-70	(S) DIODE 1N4001 1A/50V	R64		030-52220-20	RES FILM AI 22E 5% 0.4W 4X1.6MM
D30		001-00011-70	(S) DIODE 1N4001 1A/50V	R65		030-54150-20	RES FILM AI 1K5 5% 0.4W 4X1.6MM
D31		001-00015-19	(S) DIODE ZENER 5V6 0.4W 2% BZX79/B5V6	R66		030-54150-20	RES FILM AI 1K5 5% 0.4W 4X1.6MM
D32		008-00014-74	(S) LED HLMP5030 RED RT ANGLE PCB MTG	R67		030-55100-20	RES FILM AI 10K 5% 0.4W 4X1.6MM
D36		001-50012-05	(S) DIODE AI 1N4531 SI SMALL SIG	R70		030-53270-20	RES FILM AI 270E 5% 0.4W 4X1.6MM
D37		001-50012-05	(S) DIODE AI 1N4531 SI SMALL SIG	R71		030-54330-20	RES FILM AI 3K3 5% 0.4W 4X1.6MM
D41		001-50012-00	(S) DIODE AI 1N4148 SI GEN PURPOSE	R72		030-52100-20	RES FILM AI 10E 5% 0.4W 4X1.6MM
D43		001-00011-45	(S) DIODE DUAL 30A/90V 30CPQ90	R73		030-55100-20	RES FILM AI 10K 5% 0.4W 4X1.6MM
*D46		001-00012-91	(S) DIODE 16V TRANSIENT SUPPRESSOR	R74		030-54470-20	RES FILM AI 4K7 5% 0.4W 4X1.6MM
				R75		030-54470-20	RES FILM AI 4K7 5% 0.4W 4X1.6MM
*F1		265-00010-51	FUSE 5.0A 250V SLOW BLOW 5X20	R79A		032-32100-01	RES M/F PWR 10E 2.5W 17X5MM
FC1		340-00010-07	FUSE CLIP PCB MTG 5MM FUSE	R79B		032-32100-01	RES M/F PWR 10E 2.5W 17X5MM
FC2		340-00010-07	FUSE CLIP PCB MTG 5MM FUSE	R80		030-54100-20	RES FILM AI 1K 5% 0.4W 4X1.6MM
				R80A		030-52100-20	RES FILM AI 10E 5% 0.4W 4X1.6MM
				R80B		030-54180-20	RES FILM AI 1K8 5% 0.4W 4X1.6MM
IC1		002-00012-40	(S) IC 358 DUAL OP AMP	*R81		032-33150-01	RES M/F PWR 150E 5% 2.5W 17X5MM
IC2		002-00010-81	(S) IC 7815 +15V 1AMP TO -220 3PIN	*R82		032-33150-01	RES M/F PWR 150E 5% 2.5W 17X5MM
IC3		002-00012-40	(S) IC 358 DUAL OP AMP	R83		030-52220-20	RES FILM AI 22E 5% 0.4W 4X1.6MM
IC4		002-00016-61	(S) IC 3525A SMPS CTRL	R84		030-52220-20	RES FILM AI 22E 5% 0.4W 4X1.6MM
IC5		002-00010-75	(S) IC TSC426 DRIVER INVERTING MOSFET 8PIN	R85		030-08100-31	RES M/F 10M 3.5KV VR37 10*4MM
IC6		002-00010-75	(S) IC TSC426 DRIVER INVERTING MOSFET 8PIN	R86		030-55470-20	RES FILM AI 47K 5% 0.4W 4X1.6MM
IC7		002-00020-58	(S) IC CNX62A OPTOCOPLER 250VAC	R87		030-53100-20	RES FILM AI 100E 5% 0.4W 4X1.6MM
IC8		002-00014-15	(S) IC TL431 SHUNT REG TO-92	R88		030-54100-20	RES FILM AI 1K 5% 0.4W 4X1.6MM
				R89		030-54470-20	RES FILM AI 4K7 5% 0.4W 4X1.6MM
				R90		030-55470-20	RES FILM AI 47K 5% 0.4W 4X1.6MM
L1		065-00010-20	BEAD FERRITE BALUN 4B1 PHILIPS	R91		030-54100-20	RES FILM AI 1K 5% 0.4W 4X1.6MM
L2		056-00010-36	CHOKE FLTR 0.5MH COMMON MODE	RV92		042-03470-06	RES PRESET 470E CARBON 6MM FLAT
L3		056-00021-20	IND FXD 2MH 5AMP TOROIDAL	R93		030-53910-20	RES FILM AI 910E 5% 0.4W 4X1.6MM
L4		065-00010-11	BEAD FERRITE 4S3 3*1*4MM RED	R94		030-54120-20	RES FILM AI 1K2 5% 0.4W 4X1.6MM
L5		065-00010-11	BEAD FERRITE 4S3 3*1*4MM RED	R95		030-55680-20	RES FILM AI 68K 5% 0.4W 4X1.6MM
L6		065-00010-20	BEAD FERRITE BALUN 4B1 PHILIPS	R96		030-54680-20	RES FILM AI 6K8 5% 0.4W 4X1.6MM
L7		065-00010-11	BEAD FERRITE 4S3 3*1*4MM RED	R98		030-55100-20	RES FILM AI 10K 5% 0.4W 4X1.6MM
L8		065-00010-11	BEAD FERRITE 4S3 3*1*4MM RED	R99		030-54100-20	RES FILM AI 1K 5% 0.4W 4X1.6MM
<b>Note:</b> Fit L4 & L5 On Leads Of C20 Fit L7 & L8 On Leads Of C51				RLY1		237-00010-30	RELAY 12V COIL 240V 10A SPDT
PL-2		240-00020-72	HEADER 2 WAY PCB MTG ULTREX	SW1		233-00010-07	SWITCH DPDT 115/230V 6PIN
				SW2		232-00020-28	PUSH SWITCH PCB MTG
*Q1		000-00012-63	(S) XSTR MTP4N50 PWR MOSFET 500V TO220	SK-3		240-00010-23	PLUG 3 PIN 10AMP 250V PCB MTG
*Q2		000-00012-63	(S) XSTR MTP4N50 PWR MOSFET 500V TO220	SK-4		240-04030-06	TRMNL BLOCK 1WAY PC MT PHOENIX
Q3		000-50011-30	(S) XSTR AI BC557B PNP TO-92 AF S/SIG	SK-5		240-04030-06	TRMNL BLOCK 1WAY PC MT PHOENIX
Q4		000-50011-10	(S) XSTR AI BC547B NPN TO-92 AF S/SIG	SK-6		240-04030-07	TERML BLK PCB MTG 1WAY FRT 2.5H/SA10
Q6		000-00010-66	(S) XSTR BC337 NPN AF PWR TO92	SK-7		240-04030-07	TERML BLK PCB MTG 1WAY FRT 2.5H/SA10
Q7		000-50011-30	(S) XSTR AI BC557B PNP TO-92 AF S/SIG	SK-8		240-04030-07	TERML BLK PCB MTG 1WAY FRT 2.5H/SA10
Q8		000-50011-30	(S) XSTR AI BC557B PNP TO-92 AF S/SIG				
Q9		000-00010-66	(S) XSTR BC337 NPN AF PWR TO92	T1		053-00010-58	XFMR T4073 T807/808 SWITCHING
				T2		053-00010-59	XFMR T4074 T807/808 CURRENT SENSE
R1		030-08100-31	RES M/F 10M 3.5KV VR37 10*4MM	T3		053-01060-02	XFMR T4075 T807/808 MOSFET DRIVE
R2		049-00275-40	VARIATOR 275V AC 140JOULES 20MM DIA.	T4		053-00010-63	XFMR T4075 MAINS 5VA 18V
R3		035-02100-93	RES WIRE WOUND 10E 5W 19X8MM	*T5		056-00010-39	CHOKE T4072 T807 DIFFNL MODE ETD39
R4		032-35470-00	RES M/F PWR 47K 5% 1W 12X4.5MM	T6		056-00010-38	CHOKE T4071 T807-808 DIFFNL MODE
R5		030-56270-20	RES FILM AI 270K 5% 0.4W 4X1.6MM				
R6		030-56390-20	RES FILM AI 390K 5% 0.4W 4X1.6MM	TC1		239-00010-06	SWITCH THERMAL PEPI 100C BARE TERML.C/W SLEEVE
R7		032-35470-00	RES M/F PWR 47K 5% 1W 12X4.5MM				
R8		030-55680-20	RES FILM AI 68K 5% 0.4W 4X1.6MM				
R9		030-55470-20	RES FILM AI 47K 5% 0.4W 4X1.6MM				
R11		032-33100-02	RES M/F PWR 100E 5% 6W 33X9MM				
*R12		030-53180-20	RES FILM AI 180E 5% 0.4W 4X1.6MM				
R13A		030-52680-20	RES FILM AI 68E 5% 0.4W 4X1.6MM				
R13B		030-54150-20	RES FILM AI 1K5 5% 0.4W 4X1.6MM				
R14		030-54150-20	RES FILM AI 1K5 5% 0.4W 4X1.6MM				
*R17		030-52220-20	RES FILM AI 22E 5% 0.4W 4X1.6MM				
R18		030-54120-20	RES FILM AI 1K2 5% 0.4W 4X1.6MM				
*R19		030-52220-20	RES FILM AI 22E 5% 0.4W 4X1.6MM				
R20		030-54120-20	RES FILM AI 1K2 5% 0.4W 4X1.6MM				
R24		030-54120-20	RES FILM AI 1K2 5% 0.4W 4X1.6MM				
RV25		042-03470-06	RES PRESET 470E CARBON 6MM FLAT				
R26		030-53680-20	RES FILM AI 680E 5% 0.4W 4X1.6MM				
R27		030-54180-20	RES FILM AI 1K8 5% 0.4W 4X1.6MM				
R28		030-53820-20	RES FILM AI 820E 5% 0.4W 4X1.6MM				
R29		030-54270-20	RES FILM AI 2K7 5% 0.4W 4X1.6MM				
R30		030-55100-20	RES FILM AI 10K 5% 0.4W 4X1.6MM				
R32		030-56100-20	RES FILM AI 100K 5% 0.4W 4X1.6MM				
R33		030-54100-20	RES FILM AI 1K 5% 0.4W 4X1.6MM				
R34		030-55100-20	RES FILM AI 10K 5% 0.4W 4X1.6MM				
R35		030-55100-20	RES FILM AI 10K 5% 0.4W 4X1.6MM				
R36		030-55150-20	RES FILM AI 15K 5% 0.4W 4X1.6MM				
R37		030-57100-20	RES FILM AI 1M 5% 0.4W 4X1.6MM				
R38		030-55100-20	RES FILM AI 10K 5% 0.4W 4X1.6MM				
R41		030-54680-20	RES FILM AI 6K8 5% 0.4W 4X1.6MM				
R42		030-54220-20	RES FILM AI 2K2 5% 0.4W 4X1.6MM				
R43		030-55100-20	RES FILM AI 10K 5% 0.4W 4X1.6MM				
R44		030-55100-20	RES FILM AI 10K 5% 0.4W 4X1.6MM				
R46		030-56100-20	RES FILM AI 100K 5% 0.4W 4X1.6MM				
R47		030-52220-20	RES FILM AI 22E 5% 0.4W 4X1.6MM				
R49		049-00140-10	VARIATOR 140VRMS 180VDC 42 JOULES				
R50		030-54220-20	RES FILM AI 2K2 5% 0.4W 4X1.6MM				
R51		030-55100-20	RES FILM AI 10K 5% 0.4W 4X1.6MM				
R52		030-56180-20	RES FILM AI 180K 5% 0.4W 4X1.6MM				





## T807 Mechanical &amp; Miscellaneous Parts (220-01183-03)

IPN	Legend	Description	IPN	Legend	Description
200-00010-35		WIRE T/C 1.5MM/1.4MM For L1 & L6. 35mm each	356-00020-06		RECEPTL 6.3MM QUICK CONN FLARED INS For Earth Lead
201-00051-15		WIRE APPLC 1MM <sup>2</sup> GREEN HI TEMP PVC85 For Earth Lead	356-00020-07		RECEPTL M3.5QUICK CONN M3.5 OPEN END For Earth Lead
201-00060-09		WIRE REMIT 0.8MM <sup>2</sup> PVC WHITE For Cut Out Switch on T1	356-00020-21		TAB 6.3MM RT ANGLE SPADE CAR QCK CONN PCB Mounted Earth Connector
209-00010-26		TAPE COPPER 19MM * 0.08MM SCOTCH 1181 For taping switch to T1	362-00010-13	18	BUSH INSULATING 1.1MM TOP HAT D43 Mounting x1
220-01183-03	1	PCB T807/T808 SMPS 2 OUNCE COPPER	362-01024-00	19	INSULATOR 54*30 AS PER DRWG A4M2431 Q1/Q2 x1, D43 x1
240-02010-22		SKT MAINS 3PIN FLEX 2M/10A	362-01052-00	20	XSTR CLAMPING BRKT T807/808 A4M2407 Bracing bracket for Q1 & Q2 x1
240-06010-27		BLANKING PLATE 2.5MM GREEN Fitted to SK-8	365-00011-54		LABEL WHITE RW 1556/2 90X24MM SPEC AD For outside of box
303-23128-01	2	COVR SIDE A2M2403/2 T807/808 COMP SCRNM	365-00013-59		LABEL T807/808 HI VOLT WARNING A4A651
306-01010-00	3	FERRULE A4M948 HANDLE FXD EQUIP Place on handle x2	365-00100-05		LABEL BLANK 50X9MM S/A METLSD POLYES Mounting Kit x1 (in bag) NB/ Label is to be placed over top of screened version on panel if power supply is to be 115 Volts
307-02029-00		GUIDE REAR T807/808 A3M2409 Packed in box x2	365-01391-01		LABEL BLNK 30X10.8MM TAMPERMARK VOID Ser No x1, Job No x1, Rev No x1 & Elec Insp x1
308-01007-00	4	HANDLE A4M949 FXD EQUIP Front Panel	399-00010-10		RUBBER BAND NO 33
308-13088-00		HSINK CLIP ON 14 OR 16 DIP INT CCTS ICs 4, 5 & 6	399-00010-51		BAG PLASTIC 75*100MM For Mounting Kit
308-13091-00		HSINK PCB MTG TO-220 Heatsink for IC2 mounting to PCB	400-00020-01		SLEEIVING 0.7MM SIL RUBBER For Legs of R13A, R47 & R64
311-00010-39		KNOB RED PLASTIC ROUND Pushes on to SW2	400-00020-03		SLEEIVING 1MM SIL RUBBER For Legs of R3, R11, 79A, R79B, R81 & R82
316-06398-00	5	PNL FRT COMPL T807 A3M2405/2	400-00020-05		SLEEIVING 1.5MM SIL RUBBER
316-21177-02	6	PNL REAR A3M2427/2 T807 COMPL SCRNM	400-00020-07		SLEEIVING 2MM SIL RUBBER Goes over wire for L1 & L6.
318-01018-00	7	RAIL CHASSIS T807/808 A3M2404 Attached to PCB x2	410-01081-00		CRTN T800 KIWI REF22860 402X192X66MM
319-30030-01	8	SPACER A4M1115 T807/808 Between P.C.B. & Rails x6	410-01082-00		CRTN 10 T800 KIWI REF24417 423X410X360
345-00040-06	9	SCREW M3*8MM PAN POZI ST BZ SK-3 x2, Mounting Kit x2 (in bag)			
345-00040-12		SCREW M3X10MM CSK POZI ST BZ Mounting Kit x6 (in bag)			
345-00040-17	10	SCREW M3*16MM CSK POZI ST BZ D43 x1			
345-00040-24	11	SCREW M3X20MM CSK POZI ST BZ Q1/Q2 Bracing Bracket x2			
349-00020-07	12	SCREW 4-40 X 5/16 PAN POZI TAPTITE BLACK Front x4, Rear x4, Cover x4			
349-00020-08	13	SCREW TAPTITE 4-40X3/8IN CSK POZI BZ Covers to rails x16			
349-00020-34	14	SCREW M3*12 PAN POZI TAPTITE BZ P.C.B. to rails x6			
352-00010-08	15	NUT M3 COLD FORM HEX ST BZ D43 x1, Mains Socket x2, IC2 x1, Mounting Kit x2 (in bag)			
352-00010-29	16	NUT M4 NYLOC HEX Handle x2			
353-00010-10		WASHER M3 FLAT 7MM*0.6MM ST BZ Mounting Kit x2 (in bag)			
353-00010-12	17	WASHER M3 SPRING BZ OR Z/C D43 x1, Mains Socket x2, IC2 x1			

## T808 Parts List (IPN 220-01183-03)

### How To Use This Parts List

The components listed in this parts list are divided into two main types: those with a circuit reference (e.g. C2, D1, R121, etc) and those without (miscellaneous and mechanical). Static sensitive devices are prefixed with (S).

Those with a circuit reference are grouped by component type in numerical order. Each component entry comprises three or four columns: the circuit reference, variant number (if applicable), IPN and description. A number in the variant column indicates that this component is fitted only to that variant.

The miscellaneous and mechanical section lists the parts in IPN order and where possible the legend indicates their position on the exploded view.

### Parts List Amendments

R13A Changed from 10E to 68E (94/06-301).  
 R93 Changed from 1K to 910E (94/06-301).  
 R1 & R85 Changed from 030-08100-30 to -31 due to incorrect voltage rating of the original (93/07-348).  
 R1 & R85 10M added to underside of PCB to meet BAPT high voltage requirements (93/04-202).  
 FC1 & FC2 (Fuseholders) changed from 6.3mm (340-00010-06) to 5mm, due to being the wrong size (93/04-181).  
 C23 Changed from 020-08470-07 to -09 due to high profile of the original (92/10-742).

Important mechanical assembly changes to this issue are as follows:

Sidecover Changed from 303-23128-00 to -01. Width increased by 0.5mm to pass BAPT high voltage test (94/05-243).  
 Spacer Changed from 319-30030-00 to -01. Length increased by 0.5mm to pass BAPT high voltage test (94/05-243).  
 Screw 4-40 ¼" Changed from 349-00020-06 to -07 (5/16") due to obsolete component (93/08-410).  
 Gasket 362-00010-07 replaced by insulator 54\*30 (362-01024-00) to meet BAPT high voltage requirements (93/04-202).

Ref	Var	IPN	Description	Ref	Var	IPN	Description
C1		010-04220-09	CAP CER 2N2 10% 250VAC APPROVED	C60		017-15470-01	CAP CER SURFACE BARRIER 47N 20% 50V
C2		010-04220-09	CAP CER 2N2 10% 250VAC APPROVED	C61		025-08100-03	CAP 10M 35V 20% TANT 5MM L/S
C3		022-06470-04	CAP MYLAR 470N 10% 250VAC	C62		019-05470-00	CAP MONOLITHIC CER 47N 10% 50V X7R
C4		022-06470-04	CAP MYLAR 470N 10% 250VAC	C63		022-57100-02	CAP MYLAR AI 1M 20% 50V POTTED
C5		012-04220-06	CAP CER 2N2 3-PIN SUPPR FLTR	C65		020-09470-07	CAP 470M 16V 20% ELEC VERT 8*20 3.5MM L/S LO-ESR
C6		012-04220-06	CAP CER 2N2 3-PIN SUPPR FLTR	C66		024-14470-01	CAP METAL POLYPR RADL 4N7 10% 400VAC
*C9		021-09560-00	CAP 560UF ELECT 200V 105D 25DIA X40 10MMLS	C67		024-14470-01	CAP METAL POLYPR RADL 4N7 10% 400VAC
*C10		021-09560-00	CAP 560UF ELECT 200V 105D 25DIA X40 10MMLS	*C68		020-19330-02	CAP 3300M 16V ELEC 13*40 VERT
*C11		021-09560-00	CAP 560UF ELECT 200V 105D 25DIA X40 10MMLS	*C69		020-19330-02	CAP 3300M 16V ELEC 13*40 VERT
*C12		021-09560-00	CAP 560UF ELECT 200V 105D 25DIA X40 10MMLS	*C70		020-19330-02	CAP 3300M 16V ELEC 13*40 VERT
*C13		024-07100-00	CAP 1M 250VDC 5% POLYPROP.22.5 L/S	*C71		020-19330-02	CAP 3300M 16V ELEC 13*40 VERT
*C14		024-07100-00	CAP 1M 250VDC 5% POLYPROP.22.5 L/S	*C72		020-19330-02	CAP 3300M 16V ELEC 13*40 VERT
*C15		010-03470-03	CAP 470P T/C B 10% 6KV CERAMIC	*C73		020-19330-02	CAP 3300M 16V ELEC 13*40 VERT
C16		025-07100-01	CAP TANT BEAD 1M 35V	C74		010-04220-09	CAP CER 2N2 10% 250VAC APPROVED
C17		011-53470-02	CAP CER AI 470P 10% T/C B 63V	C75		010-04220-09	CAP CER 2N2 10% 250VAC APPROVED
C20		010-04100-04	CAP CER 1N 10% T/C B 400V	C78		020-09820-01	CAP 820M 16V ELECT 10X25MM
C21		022-55470-10	CAP MYLAR AI 47N 5% 63V POTTED	C79		019-05470-00	CAP MONOLITHIC CER 47N 10% 50V X7R
C22		022-55470-10	CAP MYLAR AI 47N 5% 63V POTTED	C80		010-04100-04	CAP CER 1N 10% T/C B 400V
C23		020-08470-09	CAP ELECT RADL 47M 16V 10X18MM HI TEMP	C81		010-04100-04	CAP CER 1N 10% T/C B 400V
C24		020-07100-04	CAP ELECT RADL 1M 63V 8X12MM HI TEMP	C82		010-04100-04	CAP CER 1N 10% T/C B 400V
C25		025-08100-03	CAP 10M 35V 20% TANT 5MM L/S	C84		019-05470-00	CAP MONOLITHIC CER 47N 10% 50V X7R
C26		011-54100-01	CAP CER AI 1N 10% T/C B 63V	C85		011-52330-01	CAP CER AI 33P 5% N150 50/63V
C27		011-54100-01	CAP CER AI 1N 10% T/C B 63V	C86		022-54100-10	CAP MYLAR AI 1N 5% 63V POTTED
C31		011-54100-01	CAP CER AI 1N 10% T/C B 63V	C87		022-54220-10	CAP MYLAR AI 2N2 5% 63V POTTED
C32		011-54100-01	CAP CER AI 1N 10% T/C B 63V	C88		022-55470-10	CAP MYLAR AI 47N 5% 63V POTTED
C33		019-05470-00	CAP MONOLITHIC CER 47N 10% 50V X7R	C89		011-52220-01	CAP CER AI 22P 5% N150 50/63V
C34		025-08100-03	CAP 10M 35V 20% TANT 5MM L/S	C90		010-04100-04	CAP CER 1N 10% T/C B 400V
C37		020-19220-04	CAP 2200M ELEC 35V 16X35 L ESR	C91		010-04100-04	CAP CER 1N 10% T/C B 400V
C38		019-05470-00	CAP MONOLITHIC CER 47N 10% 50V X7R	C95		011-54100-01	CAP CER AI 1N 10% T/C B 63V
C39		019-05470-00	CAP MONOLITHIC CER 47N 10% 50V X7R	D1		001-00012-30	(S) DIODE 6A6 MR 756 BY214-600 6A/600V
C42		011-54100-01	CAP CER AI 1N 10% T/C B 63V	D2		001-00012-30	(S) DIODE 6A6 MR 756 BY214-600 6A/600V
C43		011-54100-01	CAP CER AI 1N 10% T/C B 63V	D3		001-00012-30	(S) DIODE 6A6 MR 756 BY214-600 6A/600V
C44		025-07100-01	CAP TANT BEAD 1M 35V	D4		001-00012-30	(S) DIODE 6A6 MR 756 BY214-600 6A/600V
C45		011-54100-01	CAP CER AI 1N 10% T/C B 63V	D5		001-50012-05	(S) DIODE AI 1N4531 SI SMALL SIG
C46		011-54100-01	CAP CER AI 1N 10% T/C B 63V	D6		001-50012-05	(S) DIODE AI 1N4531 SI SMALL SIG
C49		019-05470-00	CAP MONOLITHIC CER 47N 10% 50V X7R	D7		001-50012-05	(S) DIODE AI 1N4531 SI SMALL SIG
C50		025-08100-03	CAP 10M 35V 20% TANT 5MM L/S	D8		001-50012-05	(S) DIODE AI 1N4531 SI SMALL SIG
C51		010-04100-04	CAP CER 1N 10% T/C B 400V	D11		001-50012-05	(S) DIODE AI 1N4531 SI SMALL SIG
C54		011-54100-01	CAP CER AI 1N 10% T/C B 63V	D12		001-50012-05	(S) DIODE AI 1N4531 SI SMALL SIG
C55		019-05470-00	CAP MONOLITHIC CER 47N 10% 50V X7R	D13		008-00014-73	(S) LED HLMP5050 GREEN RT ANGLE PCB MTG
C56		025-08100-03	CAP 10M 35V 20% TANT 5MM L/S	D14		001-00012-23	(S) DIODE BYV26C 1A/400V FAST SWITCH
C57		025-08100-03	CAP 10M 35V 20% TANT 5MM L/S				
C59		011-54100-01	CAP CER AI 1N 10% T/C B 63V				

Ref	Var	IPN	Description	Ref	Var	IPN	Description
*D15		001-00011-06	(S) DIODE MUR440 ULTRAFAST 400V 4A	R53		030-55330-20	RES FILM AI 33K 5% 0.4W 4X1.6MM
*D18		001-00011-06	(S) DIODE MUR440 ULTRAFAST 400V 4A	R54B		030-55330-20	RES FILM AI 33K 5% 0.4W 4X1.6MM
D19		001-00012-23	(S) DIODE BY26C 1A/400V FAST SWITCH	R55		045-05100-01	RES NTC 10K 5% 5MM DISC
D20		001-50012-05	(S) DIODE AI 1N4531 SI SMALL SIG	R56		030-55100-20	RES FILM AI 10K 5% 0.4W 4X1.6MM
D21		001-50012-05	(S) DIODE AI 1N4531 SI SMALL SIG	R57		030-55270-20	RES FILM AI 27K 5% 0.4W 4X1.6MM
D22		001-00013-40	(S) DIODE SCHOTTKY BAT85 0.2A/30V	R58		030-55100-20	RES FILM AI 10K 5% 0.4W 4X1.6MM
D24		001-00011-70	(S) DIODE 1N4001 1A/50V	R59		030-57100-20	RES FILM AI 1M 5% 0.4W 4X1.6MM
D25		001-00011-70	(S) DIODE 1N4001 1A/50V	R62		030-54680-20	RES FILM AI 6K8 5% 0.4W 4X1.6MM
D26		001-00011-70	(S) DIODE 1N4001 1A/50V	R63		030-52330-20	RES FILM AI 33E 5% 0.4W 4X1.6MM
D27		001-00011-70	(S) DIODE 1N4001 1A/50V	R64		030-52220-20	RES FILM AI 22E 5% 0.4W 4X1.6MM
D30		001-00011-70	(S) DIODE 1N4001 1A/50V	R65		030-54150-20	RES FILM AI 1K5 5% 0.4W 4X1.6MM
D31		001-00015-19	(S) DIODE ZENER 5V6 0.4W 2% BZX79/B5V6	R66		030-54150-20	RES FILM AI 1K5 5% 0.4W 4X1.6MM
D32		008-00014-74	(S) LED HLMP5030 RED RT ANGLE PCB MTG	R67		030-55100-20	RES FILM AI 10K 5% 0.4W 4X1.6MM
D36		001-50012-05	(S) DIODE AI 1N4531 SI SMALL SIG	R70		030-53270-20	RES FILM AI 270E 5% 0.4W 4X1.6MM
D37		001-50012-05	(S) DIODE AI 1N4531 SI SMALL SIG	R71		030-54330-20	RES FILM AI 3K3 5% 0.4W 4X1.6MM
D41		001-50012-00	(S) DIODE AI 1N4148 SI GEN PURPOSE	R72		030-52100-20	RES FILM AI 10E 5% 0.4W 4X1.6MM
D43		001-00011-45	(S) DIODE DUAL 30A/90V 30CPQ90	R73		030-55100-20	RES FILM AI 10K 5% 0.4W 4X1.6MM
*D46		001-00012-92	(S) DIODE 1N6276A 16V O/VOLT SUPPRESSOR	R74		030-54470-20	RES FILM AI 4K7 5% 0.4W 4X1.6MM
				R75		030-54470-20	RES FILM AI 4K7 5% 0.4W 4X1.6MM
*F1		265-00010-24	FUSE 8.0A 250V SLOW BLOW 5X20	R79A		032-32100-01	RES M/F PWR 10E 2.5W 17X5MM
FC1		340-00010-07	FUSE CLIP PCB MTG 5MM FUSE	R79B		032-32100-01	RES M/F PWR 10E 2.5W 17X5MM
FC2		340-00010-07	FUSE CLIP PCB MTG 5MM FUSE	R80		030-54100-20	RES FILM AI 1K 5% 0.4W 4X1.6MM
				R80A		030-52100-20	RES FILM AI 10E 5% 0.4W 4X1.6MM
				R80B		030-54180-20	RES FILM AI 1K8 5% 0.4W 4X1.6MM
IC1		002-00012-40	(S) IC 358 DUAL OP AMP	*R81		032-33120-01	RES M/F PWR 120E 5% 2.5W 17X5MM
IC2		002-00010-81	(S) IC 7815 +15V 1AMP TO -220 3PIN	*R82		032-33120-01	RES M/F PWR 120E 5% 2.5W 17X5MM
IC3		002-00012-40	(S) IC 358 DUAL OP AMP	R83		030-52220-20	RES FILM AI 22E 5% 0.4W 4X1.6MM
IC4		002-00016-61	(S) IC 3525A SMPS CTRL	R84		030-52220-20	RES FILM AI 22E 5% 0.4W 4X1.6MM
IC5		002-00010-75	(S) IC TSC426 DRIVER INVERTING MOSFET 8PIN	R85		030-08100-31	RES M/F 10M 3.5KV VR37 10*4MM
IC6		002-00010-75	(S) IC TSC426 DRIVER INVERTING MOSFET 8PIN	R86		030-55470-20	RES FILM AI 47K 5% 0.4W 4X1.6MM
IC7		002-00020-58	(S) IC CNX62A OPTOCOPLER 250VAC	R87		030-53100-20	RES FILM AI 100E 5% 0.4W 4X1.6MM
IC8		002-00014-15	(S) IC TL431 SHUNT REG TO-92	R88		030-54100-20	RES FILM AI 1K 5% 0.4W 4X1.6MM
				R89		030-54470-20	RES FILM AI 4K7 5% 0.4W 4X1.6MM
L1		065-00010-20	BEAD FERRITE BALUN 4B1 PHILIPS	R90		030-55470-20	RES FILM AI 47K 5% 0.4W 4X1.6MM
L2		056-00010-36	CHOKE FLTR 0.5MH COMMON MODE	R91		030-54100-20	RES FILM AI 1K 5% 0.4W 4X1.6MM
L3		056-00021-20	IND FXD 2MH 5AMP TOROIDAL	RV92		042-03470-06	RES PRESET 470E CARBON 6MM FLAT
L4		065-00010-11	BEAD FERRITE 4S3 3*1*4MM RED	R93		030-53910-20	RES FILM AI 910E 5% 0.4W 4X1.6MM
L5		065-00010-11	BEAD FERRITE 4S3 3*1*4MM RED	R94		030-54120-20	RES FILM AI 1K2 5% 0.4W 4X1.6MM
L6		065-00010-20	BEAD FERRITE BALUN 4B1 PHILIPS	R95		030-55680-20	RES FILM AI 68K 5% 0.4W 4X1.6MM
L7		065-00010-11	BEAD FERRITE 4S3 3*1*4MM RED	R96		030-54680-20	RES FILM AI 6K8 5% 0.4W 4X1.6MM
L8		065-00010-11	BEAD FERRITE 4S3 3*1*4MM RED	R98		030-55100-20	RES FILM AI 10K 5% 0.4W 4X1.6MM
				R99		030-54100-20	RES FILM AI 1K 5% 0.4W 4X1.6MM
<p><b>Note:</b> Fit L4 &amp; L5 On Leads Of C20 Fit L7 &amp; L8 On Leads Of C51</p>				RLY1		237-00010-30	RELAY 12V COIL 240V 10A SPDT
PL-2		240-00020-72	HEADER 2 WAY PCB MTG ULTREX	SW1		233-00010-07	SWITCH DPDT 115/230V 6PIN
				SW2		232-00020-28	PUSH SWITCH PCB MTG
*Q1		000-00012-61	(S) XSTR MTH7N50 N CHAN PWR MOS 7A 500V	SK-3		240-00010-23	PLUG 3 PIN 10AMP 250V PCB MTG
*Q2		000-00012-61	(S) XSTR MTH7N50 N CHAN PWR MOS 7A 500V	SK-4		240-04030-06	TRMNL BLOCK 1WAY PC MT PHOENIX
Q3		000-50011-30	(S) XSTR AI BC557B PNP TO-92 AF S/SIG	SK-5		240-04030-06	TRMNL BLOCK 1WAY PC MT PHOENIX
Q4		000-50011-10	(S) XSTR AI BC547B NPN TO-92 AF S/SIG	SK-6		240-04030-07	TERML BLK PCB MTG 1WAY FRT 2.5H/SA10
Q6		000-00010-66	(S) XSTR BC337 NPN AF PWR TO92	SK-7		240-04030-07	TERML BLK PCB MTG 1WAY FRT 2.5H/SA10
Q7		000-50011-30	(S) XSTR AI BC557B PNP TO-92 AF S/SIG	SK-8		240-04030-07	TERML BLK PCB MTG 1WAY FRT 2.5H/SA10
Q8		000-50011-30	(S) XSTR AI BC557B PNP TO-92 AF S/SIG				
Q9		000-00010-66	(S) XSTR BC337 NPN AF PWR TO92	T1		053-00010-58	XFMR T4073 T807/808 SWITCHING
				T2		053-00010-59	XFMR T4074 T807/808 CURRENT SENSE
R1		030-08100-31	RES M/F 10M 3.5KV VR37 10*4MM	T3		053-01060-02	XFMR T4075 T807/808 MOSFET DRIVE
R2		049-00275-40	VARIATOR 275V AC 140JOULES 20MM DIA.	T4		053-00010-63	XFMR T4075 MAINS 5VA 18V
R3		035-02100-93	RES WIRE WOUND 10E 5W 19X8MM	*T5		056-00010-49	CHOKE T4080 T808 DIFFNL MODE ETD39
R4		032-35470-00	RES M/F PWR 47K 5% 1W 12X4.5MM	T6		056-00010-38	CHOKE T4071 T807-808 DIFFNL MODE
R5		030-56270-20	RES FILM AI 270K 5% 0.4W 4X1.6MM				
R6		030-56390-20	RES FILM AI 390K 5% 0.4W 4X1.6MM	TC1		239-00010-06	SWITCH THERMAL PEPI 100C BARE TERML./C/W SLEEVE
R7		032-35470-00	RES M/F PWR 47K 5% 1W 12X4.5MM				
R8		030-55680-20	RES FILM AI 68K 5% 0.4W 4X1.6MM				
R9		030-55470-20	RES FILM AI 47K 5% 0.4W 4X1.6MM				
R11		032-33100-02	RES M/F PWR 100E 5% 6W 33X9MM				
*R12		030-53100-20	RES FILM AI 100E 5% 0.4W 4X1.6MM				
R13A		030-52680-20	RES FILM AI 68E 5% 0.4W 4X1.6MM				
R13B		030-54150-20	RES FILM AI 1K5 5% 0.4W 4X1.6MM				
R14		030-54150-20	RES FILM AI 1K5 5% 0.4W 4X1.6MM				
*R17		030-52100-20	RES FILM AI 10E 5% 0.4W 4X1.6MM				
R18		030-54120-20	RES FILM AI 1K2 5% 0.4W 4X1.6MM				
*R19		030-52100-20	RES FILM AI 10E 5% 0.4W 4X1.6MM				
R20		030-54120-20	RES FILM AI 1K2 5% 0.4W 4X1.6MM				
R24		030-54120-20	RES FILM AI 1K2 5% 0.4W 4X1.6MM				
RV25		042-03470-06	RES PRESET 470E CARBON 6MM FLAT				
R26		030-53680-20	RES FILM AI 680E 5% 0.4W 4X1.6MM				
R27		030-54180-20	RES FILM AI 1K8 5% 0.4W 4X1.6MM				
R28		030-53820-20	RES FILM AI 820E 5% 0.4W 4X1.6MM				
R29		030-54270-20	RES FILM AI 2K7 5% 0.4W 4X1.6MM				
R30		030-55100-20	RES FILM AI 10K 5% 0.4W 4X1.6MM				
R32		030-56100-20	RES FILM AI 100K 5% 0.4W 4X1.6MM				
R33		030-54100-20	RES FILM AI 1K 5% 0.4W 4X1.6MM				
R34		030-55100-20	RES FILM AI 10K 5% 0.4W 4X1.6MM				
R35		030-55100-20	RES FILM AI 10K 5% 0.4W 4X1.6MM				
R36		030-55150-20	RES FILM AI 15K 5% 0.4W 4X1.6MM				
R37		030-57100-20	RES FILM AI 1M 5% 0.4W 4X1.6MM				
R38		030-55100-20	RES FILM AI 10K 5% 0.4W 4X1.6MM				
R41		030-54680-20	RES FILM AI 6K8 5% 0.4W 4X1.6MM				
R42		030-54220-20	RES FILM AI 2K2 5% 0.4W 4X1.6MM				
R43		030-55100-20	RES FILM AI 10K 5% 0.4W 4X1.6MM				
R44		030-55100-20	RES FILM AI 10K 5% 0.4W 4X1.6MM				
R46		030-56100-20	RES FILM AI 100K 5% 0.4W 4X1.6MM				
R47		030-52220-20	RES FILM AI 22E 5% 0.4W 4X1.6MM				
R49		049-00140-10	VARIATOR 140VRMS 180VDC 42 JOULES				
R50		030-54220-20	RES FILM AI 2K2 5% 0.4W 4X1.6MM				
R51		030-55100-20	RES FILM AI 10K 5% 0.4W 4X1.6MM				
R52		030-56180-20	RES FILM AI 180K 5% 0.4W 4X1.6MM				



## T808 Mechanical &amp; Miscellaneous Parts (220-01183-03)

IPN	Legend	Description	IPN	Legend	Description
200-00010-35		WIRE T/C 1.5MM/1.4MM For L1 & L6. 35mm each	352-00010-08	15	NUT M3 COLD FORM HEX ST BZ D43 x1, Mains Socket x2, IC2 x1, Fan X4, Mounting Kit x2 (in bag)
201-00051-15		WIRE APPLC 1MM <sup>2</sup> GREEN HI TEMP PVC85 For Earth Lead	352-00010-29	16	NUT M4 NYLOC HEX Handle x2
201-00060-09		WIRE REMIT 0.8MM <sup>2</sup> PVC WHITE For Cut Out Switch on T1	353-00010-10		WASHER M3 FLAT 7MM*0.6MM ST BZ Mounting Kit x2 (in bag)
209-00010-26		TAPE COPPER 19MM * 0.08MM SCOTCH 1181 For taping switch to T1	353-00010-12	17	WASHER M3 SPRING BZ OR Z/C D43 x1, Mains Socket x2, IC2 x1, Fan x4
220-01183-03	1	PCB T807/T808 SMPS 2 OUNCE COPPER	356-00020-06		RECEPTL 6.3MM QUICK CONN FLARED INS For Earth Lead
240-02010-22		SKT MAINS 3PIN FLEX 2M/10A	356-00020-07		RECEPTL M3.5QUICK CONN M3.5 OPEN END For Earth Lead
*240-04020-72		SOCKET HOUSING 2 WAY MTG ULTREX To connect fan to PL-2	356-00020-21		TAB 6.3MM RT ANGLE SPADE CAR QCK CONN PCB Mounted Earth Connector
*240-04020-76		SKT RECEPTACLES WIRE CRIMP ULTREX To connect fan to PL-2	362-00010-13	18	BUSH INSULATING 1.1MM TOP HAT D43 Mounting x1
240-06010-27		BLANKING PLATE 2.5MM GREEN Fitted to SK-8	362-01024-00	19	INSULATOR 54*30 AS PER DRWG A4M2431 Q1/Q2 x1, D43 x1
*258-00010-04	22	FAN 12V TUBEAXIAL 40x40x20 MM Mount on rear panel	362-01052-00	20	XSTR CLAMPING BRKT T807/808 A4M2407 Bracing bracket for Q1 & Q2 x1
303-23128-01	2	COVR SIDE A2M2403/2 T807/808 COMP SCRNM	365-00011-54		LABEL WHITE RW 1556/2 90X24MM SPEC AD For outside of box
306-01010-00	3	FERRULE A4M948 HANDLE FXD EQUIP Place on handle x2	365-00013-59		LABEL T807/808 HI VOLT WARNING A4A651
307-02029-00		GUIDE REAR T807/808 A3M2409 Packed in box x2	365-00100-05		LABEL BLANK 50X9MM S/A METLSD POLYES Mounting Kit x1 (in bag) NB/ Label is to be placed over top of screened version on panel if power supply is to be 115 Volts
308-01007-00	4	HANDLE A4M949 FXD EQUIP Front Panel	365-01391-01		LABEL BLNK 30X10.8MM TAMPERMARK VOID Ser No x1, Job No x1, Rev No x1 & Elec Insp x1
308-13088-00		HSINK CLIP ON 14 OR 16 DIP INT CCTS ICs 4, 5 & 6	399-00010-10		RUBBER BAND NO 33
308-13091-00		HSINK PCB MTG TO-220 Heatsink for IC2 mounting to PCB	399-00010-51		BAG PLASTIC 75*100MM For Mounting Kit
311-00010-39		KNOB RED PLASTIC ROUND Pushes on to SW2	400-00020-01		SLEEING 0.7MM SIL RUBBER For Legs of R13A, R47 & R64
316-06399-00	5	PNL FRT COMPL T807 A3M2405/2	400-00020-03		SLEEING 1MM SIL RUBBER For Legs of R3, R11, 79A, R79B, R81 & R82
316-21176-02	6	PNL REAR A3M2427/2 T807 COMPL SCRNM	400-00020-05		SLEEING 1.5MM SIL RUBBER
318-01018-00	7	RAIL CHASSIS T807/808 A3M2404 Attached to PCB x2	400-00020-07		SLEEING 2MM SIL RUBBER Goes over wire for L1 & L6.
319-30030-01	8	SPACER A4M1115 T807/808 Between P.C.B. & Rails x6	410-01081-00		CRTN T800 KIWI REF22860 402X192X66MM
345-00040-06	9	SCREW M3*8MM PAN POZI ST BZ SK-3 x2, Mounting Kit x2 (in bag)	410-01082-00		CRTN 10 T800 KIWI REF24417 423X410X360
345-00040-12		SCREW M3X10MM CSK POZI ST BZ Mounting Kit x6 (in bag)			
345-00040-17	10	SCREW M3*16MM CSK POZI ST BZ D43 x1			
*345-00040-19	21	SCREW M3*25MM PAN POZI ST BZ Fan x4			
345-00040-24	11	SCREW M3X20MM CSK POZI ST BZ Q1/Q2 Bracing Bracket x2			
349-00020-07	12	SCREW 4-40 X 5/16 PAN POZI TAPTITE BLACK Front x4, Rear x4, Cover x4			
349-00020-08	13	SCREW TAPTITE 4-40X3/8IN CSK POZI BZ Covers to rails x16			
349-00020-34	14	SCREW M3*12 PAN POZI TAPTITE BZ P.C.B. to rails x6			

**T808 Mechanical Assembly Exploded View**

***replace A4 pages B8.2.13/B8.2.14 with A3  
pages B8.2.13/B8.2.14, file name 800b82b.100***

T808 Mechanical Assembly Exploded View

***replace A4 pages B8.2.13/B8.2.14 with A3  
pages B8.2.13/B8.2.14, file name 800b82b.100***



## T807/808 Grid Reference Index (IPN 220-01183-03)

**How To Use This Grid Reference Index**

The first digit in the PCB layout reference is a "1" or "2", indicating the top or bottom side layout respectively, and the last two characters give the location of the component on that diagram.

The first digit in the circuit diagram reference is the sheet number, and the last two characters give the location of the component on that sheet.

**Note:** There is a silk screen printing error on the Issue 03 PCB. D36 and D37 are shown the wrong way around. This Grid Reference Index and the PCB Layout show these components in the correct positions.

Device	PCB	Circuit	Device	PCB	Circuit	Device	PCB	Circuit	Device	PCB	Circuit
C1	1:U11	1-C6	C74	1:R3	1-N9			1-D1	R34	1:G7	1-M3
C2	1:U12	1-C5	C75	1:R2	1-N8	IC4	1:Q6	1-L0	R35	1:G8	1-M3
C3	1:T11	1-C6	C78	1:V3	1-P8	IC5	1:R5	1-M1	R36	1:M6	1-M3
C4	1:R11	1-D6	C79	1:W3	1-Q8			1-N1	R37	1:M6	1-M2
C5	1:P10	1-D6	C80	1:X2	1-R9			1-M0	R38	1:M6	1-P2
C6	1:P12	1-D5	C81	1:X3	1-R8	IC6	1:R6	1-M1	R41	1:H7	1-N3
*C9	1:K9	1-F6	C82	1:X4	1-R7			1-N1	R42	1:E7	1-P3
*C10	1:H11	1-G6	C84	1:R7	1-N6			1-N0	R43	1:E7	1-P3
*C11	1:H9	1-F5	C85	1:S4	1-P6	IC7	1:S6	1-N6	R44	1:G8	1-Q3
*C12	1:K11	1-G5	C86	1:N4	1-P5	IC8	1:S5	1-P5	R47	1:G6	1-N0
*C13	1:J8	1-H5	C87	1:N5	1-P5	L1	1:X10	1-A6	R49	1:N10	1-B2
*C14	1:L8	1-H6	C88	1:N5	1-Q5	L2	1:V11	1-B6	R50	1:V6	1-E2
*C15	1:D3	1-H5	C89	1:N5	1-R5	L3	1:S11	1-C6	R51	1:W7	1-F2
C16	1:B11	1-K5	C90	1:X3	1-R6	L4	1:C12	1-K4	R52	1:V5	1-G3
C17	1:C8	1-J4	C91	1:X4	1-R5	L5	1:C12	1-K3	R53	1:U7	1-F2
C20	1:C12	1-K4	C95	1:T5	1-P7	L6	1:W3	1-Q9	R54B	1:U5	1-F2
C21	1:D8	1-J3	D1	1:N10	1-F6	L7	1:W5	1-D0	R55	1:W6	1-E1
C22	1:G6	1-L4	D2	1:N9	1-F6	L8	1:W5	1-D0	R56	1:W6	1-F0
C23	1:F6	1-M4	D3	1:N8	1-F6	PL-1	1:D9	1-E0	R57	1:W6	1-F1
C24	1:F7	1-M3	D4	1:M9	1-F6			1-E3	R58	1:W6	1-F0
C25	1:N6	1-M2	D5	1:D7	1-J4	PL-2	1:T6	1-H0	R59	1:V5	1-G1
C26	1:N6	1-M2	D6	1:D8	1-J4	*Q1	1:G12	1-L6	R61	1:G8	1-Q3
C27	1:L6	1-N2	D7	1:C8	1-J3	*Q2	1:E12	1-L4	R62	1:U6	1-G1
C31	1:E8	1-P3	D8	1:C7	1-J3	Q3	1:H6	1-L3	R63	1:U6	1-H0
C32	1:G8	1-P3	D11	1:C12	1-H2	Q4	1:M6	1-N2	R64	1:V6	1-D1
C33	1:H8	1-Q2	D12	1:B11	1-J5	Q6	1:U6	1-H1	R65	1:B11	1-J2
C34	1:H8	1-Q2	D13	1:A11	1-K5	Q7	1:B11	1-J2	R66	1:B11	1-J2
C37	1:P9	1-C2	D14	1:G11	1-L6	Q8	1:T5	1-P7	R67	1:C11	1-J2
C38	1:N7	1-D2	*D15	1:G12	1-L6	Q9	1:H5	1-K8	R70	1:P5	1-L2
C39	1:P7	1-E2	*D18	1:E12	1-L5	R1	2:X10		R71	1:P6	1-K1
C42	1:W7	1-E2	D19	1:E11	1-L4	R2	1:N11	1-E6	R72	1:P6	1-K1
C43	1:V5	1-F2	D20	1:H7	1-N4	R3	1:U10	1-E6	R73	1:P4	1-K0
C44	1:U5	1-F2	D21	1:H7	1-P4	R4	1:M8	1-G6	R74	1:P6	1-M2
C45	1:W6	1-F1	D22	1:N6	1-M3	R5	1:L10	1-G6	R75	1:Q6	1-M2
C46	1:W6	1-F0	D24	1:Q8	1-C2	R6	1:L10	1-G5	R79A	1:G2	1-H9
C49	1:U6	1-D1	D25	1:P8	1-C2	R7	1:M10	1-G5	R79B	1:G2	1-J9
C50	1:V6	1-E1	D26	1:N8	1-C2	R8	1:L11	1-G5	R80	1:W8	1-J9
C51	1:W5	1-D0	D27	1:P8	1-C2	R9	1:G10	1-H5	R80A	1:F4	1-J8
C54	1:P5	1-K0	D30	1:U7	1-F3	R11	1:D2	1-J6	R80B	1:G5	1-K8
C55	1:Q5	1-K2	D31	1:V7	1-F2	*R12	1:C7	1-J4	*R81	1:K5	1-K9
C56	1:P4	1-K2	D32	1:A11	1-J2	R13A	1:B10	1-J5	*R82	1:K5	1-K9
C57	1:Q5	1-K2	D36	1:P6	1-L1	R13B	1:B11	1-K5	R83	1:U5	1-Q8
C59	1:P6	1-K1	D37	1:Q6	1-M1	R14	1:C11	1-K5	R84	1:T5	1-Q8
C60	1:Q5	1-M2	D41	1:G4	1-J8	*R17	1:F12	1-M5	R85	2:X2	
C61	1:Q6	1-K0	D43	1:G2	1-H9	R18	1:F12	1-L5	R86	1:T4	1-N7
C62	1:Q6	1-K0			1-H9	*R19	1:D12	1-M5	R87	1:T4	1-P6
C63	1:H7	1-N1	*D46	1V3:	1-P8	R20	1:D12	1-M4	R88	1:S5	1-P6
C65	1:G5	1-K8	*FAN	1:Z8	1-J1	R24	1:D8	1-K4	R89	1:T4	1-Q6
C66	1:H3	1-H8	*F1	1:W10	1-B6	RV25	1:F8	1-K4	R90	1:S4	1-P6
C67	1:F3	1-J8	HS	1:P7		RV26	1:E8	1-K3	R91	1:N4	1-N5
*C68	1:N2	1-L8	IC1	1:G8	1-M4	R27	1:G6	1-L4	RV92	1:S5	1-Q5
*C69	1:P2	1-L8			1-Q3	R28	1:G6	1-L4	R93	1:T5	1-Q5
*C70	1:Q2	1-M8			1-Q2	R29	1:H6	1-L3	R94	1:P5	1-Q5
*C71	1:N3	1-M8	IC2	1:P7	1-D3	R30	1:G7	1-M4	R95	1:N5	1-Q4
*C72	1:P3	1-M8	IC3	1:U5	1-G2	R32	1:G6	1-M4	R96	1:N5	1-R5
*C73	1:Q3	1-N8			1-G0	R33	1:G7	1-M3	R98	1:W4	1-P7

<u>Device</u>	<u>PCB</u>	<u>Circuit</u>	<u>Device</u>	<u>PCB</u>	<u>Circuit</u>	<u>Device</u>	<u>PCB</u>	<u>Circuit</u>	<u>Device</u>	<u>PCB</u>	<u>Circuit</u>
R99	1:W4	1-P7									
RLY1	1:V8	1-J9									
		1-F6									
SW1	1:N12	1-E5									
		1-A3									
SW2	1:C9	1-J3									
SK-1		1-E0									
		1-E3									
SK-2		1-H0									
SK-3	1:X10	1-A4									
SK-4	1:X2	1-R9									
SK-5	1:X3	1-R8									
SK-6	1:Y3	1-R6									
SK-7	1:Y3	1-R6									
SK-8	1:Y4	1-R7									
T1	1:C5	1-J6									
T2	1:B8	1-J5									
T3	1:F10	1-M4									
T4	1:S8	1-B2									
*T5	1:K3	1-K8									
T6	1:T3	1-P8									
TAB-1	1:Y8	1-A7									
TC1		1-E3									
TP1	1:N7	1-G6									
TP2	1:G10	1-G5									
TP3	1:D8	1-J4									
TP4	1:L7	1-B0									
		1-C1									
TP5	1:C9	1-E3									
TP6	1:K7	1-P1									
TP7	1:J7	1-P1									

## T807/808 Noise Modulator Parts List (IPN 220-01268-00)

### How To Use This Parts List

The components listed in this parts list are divided into two main types: those with a circuit reference (e.g. C2, D1, R121, etc) and those without (miscellaneous and mechanical).

Those with a circuit reference are grouped by component type in numerical order. Each component entry comprises three or four columns: the circuit reference, variant number (if applicable), IPN and description. A number in the variant column indicates that this component is fitted only to that variant.

The miscellaneous and mechanical section lists the variant and common parts in IPN order.

### Parts List Amendments

There were no amendments to the parts list at the time of publication.

Ref	Var	IPN	Description	Ref	Var	IPN	Description
C1		025-08100-02	CAP TANT BEAD 10M 10% 16V				
C2		025-08100-02	CAP TANT BEAD 10M 10% 16V				
C3		022-06100-01	CAP MYLAR 100N10% 50V				
C4		011-52220-01	CAP CER AI 22P5% N15050/63V				
C5		022-06100-01	CAP MYLAR 100N10% 50V				
Q1		000-50011-10	(S) XSTR AI BC547B NPNT0-92 AF S/SIG				
Q2		000-50011-10	(S) XSTR AI BC547B NPNT0-92 AF S/SIG				
Q3		000-00033-10	(S) XSTR J310 JFET TO-92 UHF 2.5MM L/S				
R1		030-55560-20	RES FILM AI 56K 5% 0.4W 4X1.6MM				
R2		030-55560-20	RES FILM AI 56K 5% 0.4W 4X1.6MM				
R3		030-55100-20	RES FILM AI 10K 5% 0.4W 4X1.6MM				
R4		030-54330-20	RES FILM AI 3K3 5% 0.4W 4X1.6MM				
R5		030-57100-20	RES FILM AI 1M5% 0.4W4X1.6MM				
		200-00010-04	WIRE T/C 0.7MM (2 x 30mm lengths)				
		201-00060-04	WIRE REMIT 0.8MM2 PVC YELLOW				
		201-00060-09	WIRE REMIT 0.8MM2 PVC WHITE				
		220-01268-00	PCB T807/808 NOISE MODULATOR				
		369-00020-36	TAPE VINYL FOAM 2 SIDES/A 25.4*3MM 3M4408				

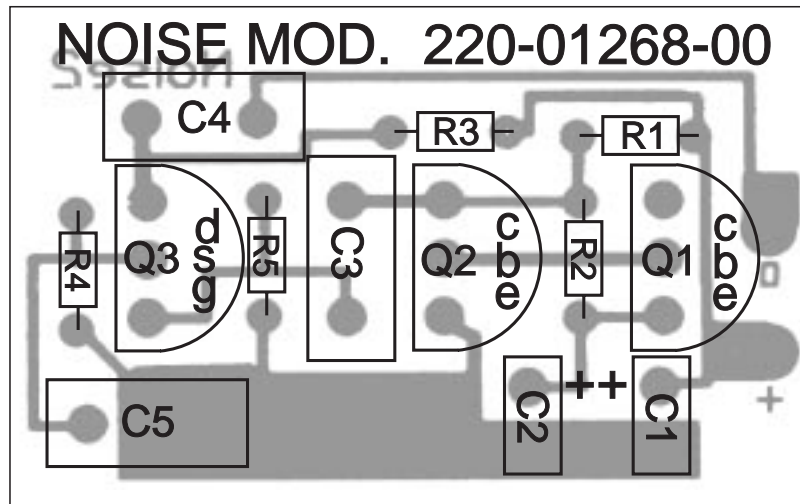

T807/808 Noise Modulator PCB (IPN 220-01268-00) - Top Side Encoding Overlaid On Bottom Side Copper

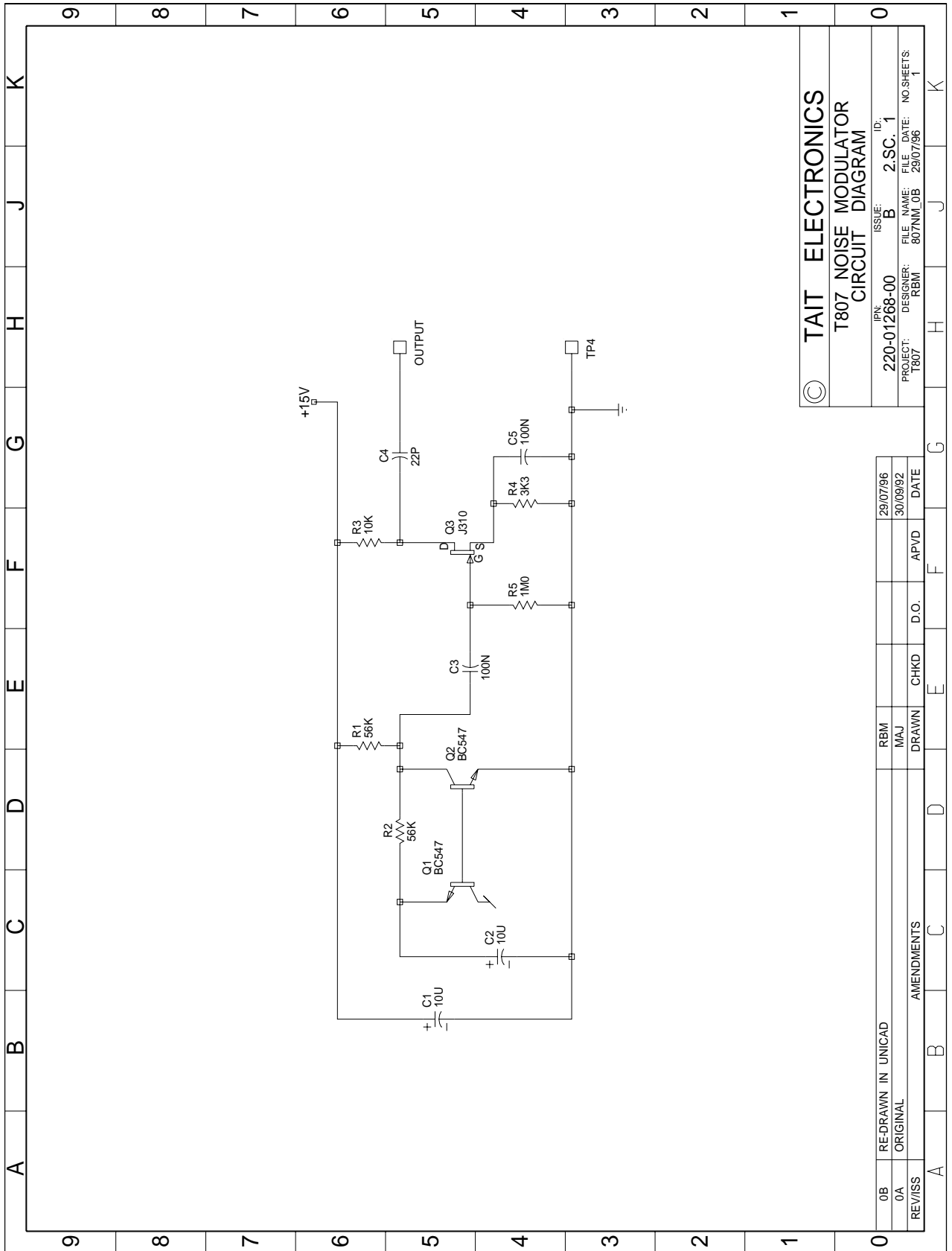

© TAIT ELECTRONICS  
 T807 NOISE MODULATOR  
 CIRCUIT DIAGRAM

IPN: 220-01268-00 ISSUE: B 2.S.C. 1  
 PROJECT: T807 DESIGNER: RBM FILE NAME: 807NM\_0B DATE: 29/07/96 NO. SHEETS: 1

REV/ISS	AMENDMENTS	APVD	DATE
0B	RE-DRAWN IN UNICAD		29/07/96
0A	ORIGINAL		30/09/92

REVISION	APPROVED	DATE
0B	MAJ	29/07/96
0A	MAJ	30/09/92

T807/808 Noise Modulator PCB (IPN 220-01268-00) - Circuit Diagram



## T807 Parts List (IPN 220-01183-05)

### How To Use This Parts List

The components listed in this parts list are divided into two main types: those with a circuit reference (e.g. C2, D1, R121, etc) and those without (miscellaneous and mechanical).

Those with a circuit reference are grouped by component type in numerical order. Each component entry comprises three or four columns: the circuit reference, variant number (if applicable), IPN and description. A number in the variant column indicates that this component is fitted only to that variant.

The miscellaneous and mechanical section lists the parts in IPN order and where possible the legend indicates their position on the exploded view.

### Parts List Amendments

C1 & C2 Changed from 2.2n (010-04220-09) to 4.7n to meet European Type Approval (95/09-7077).  
 C3 & C4 Changed from 470n (022-06470-04) to 680n to meet European Type Approval (95/09-7077).  
 C5 & C6 Changed from 2.2n (012-04220-06) to 4.7n to meet European Type Approval (95/09-7077).  
 C5A & C6A 4.7n added in parallel with C5 & C6 respectively to meet European Type Approval (95/09-7077).  
 L1 & L1A Added in place of L1 (065-00010-20) to meet European Type Approval (95/09-7077).  
 C19 10n (022-55100-10) deleted from circuit to increase stability of short circuit test (95/08-7024).  
 C100 10n added to underside of PCB to increase stability of short circuit test (95/08-7024).  
 C101 100p added to underside of PCB to increase stability of short circuit test (95/08-7024).  
 PL-2 Deleted from Parts List. Only fitted to T808-10 (95/11-7106).

Important mechanical assembly changes to this issue are as follows:

Rear Panel Changed from 316-21177-02 to -03. Change temperature rating from  $T_a=60^{\circ}\text{C}$  to  $T_a=40^{\circ}\text{C}$  (96/05-7070).

Ref	Var	IPN	Description	Ref	Var	IPN	Description
*C1		010-04470-09	CAP CERAMIC 4N7 +-20% 250VAC APPROVED	C57		025-08100-04	(L) CAP 10M 35V 10% TANT 2.5MM L/S
*C2		010-04470-09	CAP CERAMIC 4N7 +-20% 250VAC APPROVED	C59		011-54100-01	CAP CER AI 1N 10% T/C B 63V
*C3		022-06680-04	CAP MYLAR 680N +- 20% 250VAC APPROVED	C60		017-15470-01	CAP CER SURFACE BARRIER 47N 20% 50V
*C4		022-06680-04	CAP MYLAR 680N +- 20% 250VAC APPROVED	C61		025-08100-04	CAP 10M 35V 10% TANT 2.5MM L/S
*C5		010-04470-09	CAP CERAMIC 4N7 +-20% 250VAC APPROVED	C62		019-05470-00	CAP MONOLITHIC CER 47N 10% 50V X7R
*C5A		010-04470-09	CAP CERAMIC 4N7 +-20% 250VAC APPROVED	C63		022-57100-02	CAP MYLAR AI 1M 20% 50V POTTED
*C6		010-04470-09	CAP CERAMIC 4N7 +-20% 250VAC APPROVED	C65		020-09470-07	CAP 470M 16V 20% ELEC VERT 8*20 3.5MM L/S LO-ESR
*C6A		010-04470-09	CAP CERAMIC 4N7 +-20% 250VAC APPROVED	C66		024-14470-01	CAP METAL POLYPR RADL 4N7 10% 400VAC
*C9		021-09390-00	CAP 390UF ELECT 200V 105D 25DIA X40 10MMLS	C67		024-14470-01	CAP METAL POLYPR RADL 4N7 10% 400VAC
*C10		021-09390-00	CAP 390UF ELECT 200V 105D 25DIA X40 10MMLS	*C68		020-19220-02	CAP ELECT RAD 2200M 16V 12.5X30MM LO ESR
*C11		021-09390-00	CAP 390UF ELECT 200V 105D 25DIA X40 10MMLS	*C69		020-19220-02	CAP ELECT RAD 2200M 16V 12.5X30MM LO ESR
*C12		021-09390-00	CAP 390UF ELECT 200V 105D 25DIA X40 10MMLS	*C70		020-19220-02	CAP ELECT RAD 2200M 16V 12.5X30MM LO ESR
*C13		024-06680-08	CAP POLYPR AXIAL 680N 20% 250VDC	*C71		020-19220-02	CAP ELECT RAD 2200M 16V 12.5X30MM LO ESR
*C14		024-06680-08	CAP POLYPR AXIAL 680N 20% 250VDC	*C72		020-19220-02	CAP ELECT RAD 2200M 16V 12.5X30MM LO ESR
*C15		010-03220-03	CAP CER 220P 10% T/C B 6KV	*C73		020-19220-02	CAP ELECT RAD 2200M 16V 12.5X30MM LO ESR
C16		025-07100-01	CAP TANT BEAD 1M 35V	C74		010-04220-09	CAP CER 2N2 10% 250VAC APPROVED
C17		011-53470-02	CAP CER AI 470P 10% T/C B 63V	C75		010-04220-09	CAP CER 2N2 10% 250VAC APPROVED
C18		011-03680-01	CAP CER 680P 10% N1K5 50/63V	C78		020-09820-01	CAP 820M 16V ELECT 10X25MM
C20		010-04100-04	CAP CER 1N 10% T/C B 400V	C79		019-05470-00	CAP MONOLITHIC CER 47N 10% 50V X7R
C21		022-55470-10	CAP MYLAR AI 47N 5% 63V POTTED	C80		010-04100-04	CAP CER 1N 10% T/C B 400V
C22		022-55470-10	CAP MYLAR AI 47N 5% 63V POTTED	C81		010-04100-04	CAP CER 1N 10% T/C B 400V
C23		020-08470-07	CAP ELECT RADL 47M 16V 8X11.5MM HI TEMP	C82		010-04100-04	CAP CER 1N 10% T/C B 400V
C24		020-07100-04	CAP ELECT RADL 1M 63V 8X12MM HI TEMP	C84		019-05470-00	CAP MONOLITHIC CER 47N 10% 50V X7R
C25		025-08100-04	(L) CAP 10M 35V 10% TANT 2.5MM L/S	C85		011-52330-01	CAP CER AI 33P 5% N150 50/63V
C26		011-54100-01	CAP CER AI 1N 10% T/C B 63V	C86		022-54100-10	CAP MYLAR AI 1N 5% 63V POTTED
C27		011-54100-01	CAP CER AI 1N 10% T/C B 63V	C87		022-54220-10	CAP MYLAR AI 2N2 5% 63V POTTED
C31		011-54100-01	CAP CER AI 1N 10% T/C B 63V	C88		022-55470-10	CAP MYLAR AI 47N 5% 63V POTTED
C32		011-54100-01	CAP CER AI 1N 10% T/C B 63V	C89		011-52220-01	CAP CER AI 22P 5% N150 50/63V
C33		019-05470-00	CAP MONOLITHIC CER 47N 10% 50V X7R	C90		010-04100-04	CAP CER 1N 10% T/C B 400V
C34		025-08100-04	(L) CAP 10M 35V 10% TANT 2.5MM L/S	C91		010-04100-04	CAP CER 1N 10% T/C B 400V
C35		011-54100-01	CAP CER AI 1N 10% T/C B 63V	C95		011-54100-01	CAP CER AI 1N 10% T/C B 63V
C37		020-19220-04	CAP 2200M ELEC 35V 16X35 L ESR	C96		022-56100-10	CAP MYLAR AI 100N 5% 63V POTTED
C38		019-05470-00	CAP MONOLITHIC CER 47N 10% 50V X7R	C98		025-08100-04	(L) CAP 10M 35V 10% TANT 2.5MM L/S
C39		019-05470-00	CAP MONOLITHIC CER 47N 10% 50V X7R	C99		011-52220-01	CAP CER AI 22P 5% N150 50/63V
C42		011-54100-01	CAP CER AI 1N 10% T/C B 63V	C100		019-55100-01	CAP MONOLITHIC AI 10N 5% COG 50V
C43		011-54100-01	CAP CER AI 1N 10% T/C B 63V	C101		011-03100-06	CAP CER 100P 5% N750 50/63V
C44		025-07100-01	CAP TANT BEAD 1M 35V	D1		001-00012-30	(S) DIODE 6A6 MR 756 BY214-600 6A/600V
C45		011-54100-01	CAP CER AI 1N 10% T/C B 63V	D2		001-00012-30	(S) DIODE 6A6 MR 756 BY214-600 6A/600V
C46		011-54100-01	CAP CER AI 1N 10% T/C B 63V	D3		001-00012-30	(S) DIODE 6A6 MR 756 BY214-600 6A/600V
C49		019-05470-00	CAP MONOLITHIC CER 47N 10% 50V X7R	D4		001-00012-30	(S) DIODE 6A6 MR 756 BY214-600 6A/600V
C50		025-08100-04	(L) CAP 10M 35V 10% TANT 2.5MM L/S	D5		001-50012-05	(S) DIODE AI 1N4531 SI SMALL SIG
C51		010-04100-04	CAP CER 1N 10% T/C B 400V	D6		001-50012-05	(S) DIODE AI 1N4531 SI SMALL SIG
C54		011-54100-01	CAP CER AI 1N 10% T/C B 63V	D7		001-50012-05	(S) DIODE AI 1N4531 SI SMALL SIG
C55		019-05470-00	CAP MONOLITHIC CER 47N 10% 50V X7R				
C56		025-08100-04	(L) CAP 10M 35V 10% TANT 2.5MM L/S				







## T807 Mechanical &amp; Miscellaneous Parts (220-01183-05)

IPN	Legend	Description	IPN	Legend	Description
200-00010-35		WIRE T/C 1.5MM <sup>2</sup> /1.4MM For L6. 35mm	353-00010-12	17	WASHER M3 SPRING BZ OR Z/C D43 x1, Mains Socket x2, IC2 x1
201-00051-15		WIRE APPLC 1MM <sup>2</sup> GREEN HI TEMP PVC85 For Earth Lead	356-00020-06		RECEPTL 6.3MM QUICK CONN FLARED INS For Earth Lead
201-00060-09		WIRE REMIT 0.8MM <sup>2</sup> PVC WHITE For Cut Out Switch on T1	356-00020-07		RECEPTL M3.5QUICK CONN M3.5 OPEN END For Earth Lead
209-00010-26		TAPE COPPER 19MM * 0.08MM SCOTCH 1181 For taping switch to T1	356-00020-21		TAB 6.3MM RT ANGLE SPADE CAR QCK CONN PCB Mounted Earth Connector
220-01183-05	1	PCB T807/T808 SMPS 2 OUNCE COPPER	362-00010-13	18	BUSH INSULATING 1.1MM TOP HAT D43 Mounting x1
240-02010-22		SKT MAINS 3PIN FLEX 2M/10A	362-01024-00	19	INSULATOR 54*30 AS PER DRWG A4M2431 Q1/Q2 x1, D43 x1
240-06010-27		BLANKING PLATE 2.5MM GREEN Fitted to SK-8	362-01052-00	20	XSTR CLAMPING BRKT T807/808 A4M2407 Bracing bracket for Q1 & Q2 x1
303-23128-01	2	COVR SIDE A2M2403/2 T807/808 COMP SCRNM	365-00011-54		LABEL WHITE RW 1556/2 90X24MM SPEC AD For outside of box
306-01010-00	3	FERRULE A4M948 HANDLE FXD EQUIP Place on handle x2	365-00013-59		LABEL T807/808 HI VOLT WARNING A4A651
307-02029-00		GUIDE REAR T807/808 A3M2409 Packed in box x2	365-00100-05		LABEL BLANK 50X9MM S/A METLSD POLYES Mounting Kit x1 (in bag) NB/ Label is to be placed over top of screened version on panel if power supply is to be 115 Volts
308-01007-00	4	HANDLE A4M949 FXD EQUIP Front Panel	365-01391-01		LABEL BLNK 30X10.8MM TAMPERMARK VOID Ser No x1, Job No x1, Rev No x1 & Elec Insp x1
308-13088-00		HSINK CLIP ON 14 OR 16 DIP INT CCTS ICs 4, 5 & 6	*365-01500-00		LABEL CE CONFORMITY 12*24MM Placed on outside of box
308-13091-00		HSINK PCB MTG TO-220 Heatsink for IC2 mounting to PCB	399-00010-10		RUBBER BAND NO 33
311-00010-39		KNOB RED PLASTIC ROUND Pushes on to SW2	399-00010-51		BAG PLASTIC 75*100MM For Mounting Kit
316-06398-01	5	PNL FRT COMPL T807 A3M2405/2	400-00020-01		SLEEING 0.7MM SIL RUBBER For Legs of R13A, R47 & R64
316-21177-03	6	PNL REAR A3M2427/2 T807 COMPL SCRNM	400-00020-03		SLEEING 1MM SIL RUBBER For Legs of R3, R11, 79A, R79B, R81 & R82
318-01018-00	7	RAIL CHASSIS T807/808 A3M2404 Attached to PCB x2	400-00020-05		SLEEING 1.5MM SIL RUBBER
*319-01189-00		SHIELD, T807 MAINS FILTER Fitted to underside of PCB across input	400-00020-07		SLEEING 2MM SIL RUBBER Goes over wire on L6.
319-30030-01	8	SPACER A4M1115 T807/808 Between P.C.B. & Rails x6	410-01081-00		CRTN T800 KIWI REF22860 402X192X66MM
345-00040-06	9	SCREW M3*8MM PAN POZI ST BZ SK-3 x2, Mounting Kit x2 (in bag)	410-01082-00		CRTN 10 T800 KIWI REF24417 423X410X360
345-00040-12		SCREW M3X10MM CSK POZI ST BZ Mounting Kit x6 (in bag)			
345-00040-17	10	SCREW M3*16MM CSK POZI ST BZ D43 x1			
345-00040-24	11	SCREW M3X20MM CSK POZI ST BZ Q1/Q2 Bracing Bracket x2			
349-00020-07	12	SCREW 4-40 X 5/16 PAN POZI TAPTITE BLACK Front x4, Rear x4, Cover x4			
349-00020-08	13	SCREW TAPTITE 4-40X3/8IN CSK POZI BZ Covers to rails x16			
349-00020-34	14	SCREW M3*12 PAN POZI TAPTITE BZ P.C.B. to rails x6			
352-00010-08	15	NUT M3 COLD FORM HEX ST BZ D43 x1, Mains Socket x2, IC2 x1, Mounting Kit x2 (in bag)			
352-00010-29	16	NUT M4 NYLOC HEX Handle x2			
353-00010-10		WASHER M3 FLAT 7MM*0.6MM ST BZ Mounting Kit x2 (in bag)			

## T808 Parts List (IPN 220-01183-05)

**How To Use This Parts List**

The components listed in this parts list are divided into two main types: those with a circuit reference (e.g. C2, D1, R121, etc) and those without (miscellaneous and mechanical). Static sensitive devices are prefixed with (S).

Those with a circuit reference are grouped by component type in numerical order. Each component entry comprises three or four columns: the circuit reference, variant number (if applicable), IPN and description. A number in the variant column indicates that this component is fitted only to that variant.

The miscellaneous and mechanical section lists the parts in IPN order and where possible the legend indicates their position on the exploded view.

**Parts List Amendments**

C19 10n (022-55100-10) deleted from circuit to increase stability of short circuit test (95/08-7024).  
 C100 10nF added to underside of PCB to increase stability of short circuit test (95/08-7024).  
 C101 100pF added to underside of PCB to increase stability of short circuit test (95/08-7024).  
 C104 1nF added to underside of PCB to increase stability of short circuit test (96/01-7003).  
 R106 & R107 100E added in series with D20 & D21 to increase stability of short circuit test (96/01-7003).  
 L9 & L10 F8 Ferrite Bead fitted over R17 & R19 to increase stability of short circuit test (96/01-7003).

Important mechanical assembly changes to this issue are as follows:

Rear Panel Changed from 316-21176-02 to -03. Change temperature rating from  $T_a=60^{\circ}\text{C}$  to  $T_a=40^{\circ}\text{C}$  (96/05-7070).

Ref	Var	IPN	Description	Ref	Var	IPN	Description
*C1		010-04220-09	CAP CER 2N2 10% 250VAC APPROVED	C66		024-14470-01	CAP METAL POLYPR RADL 4N7 10% 400VAC
*C2		010-04220-09	CAP CER 2N2 10% 250VAC APPROVED	C67		024-14470-01	CAP METAL POLYPR RADL 4N7 10% 400VAC
*C3		022-06470-04	CAP MYLAR 470N 10% 250VAC	*C68		021-19330-02	CAP 3300M 16V ELEC 13*40 VERT
*C4		022-06470-04	CAP MYLAR 470N 10% 250VAC	*C69		021-19330-02	CAP 3300M 16V ELEC 13*40 VERT
*C5		012-04220-06	CAP CER 2N2 3-PIN SUPPR FLTR	*C70		021-19330-02	CAP 3300M 16V ELEC 13*40 VERT
*C6		012-04220-06	CAP CER 2N2 3-PIN SUPPR FLTR	*C71		021-19330-02	CAP 3300M 16V ELEC 13*40 VERT
*C9		021-09560-00	CAP 560UF ELECT 200V 105D 25DIA X40 10MML/S	*C72		021-19330-02	CAP 3300M 16V ELEC 13*40 VERT
*C10		021-09560-00	CAP 560UF ELECT 200V 105D 25DIA X40 10MML/S	*C73		021-19330-02	CAP 3300M 16V ELEC 13*40 VERT
*C11		021-09560-00	CAP 560UF ELECT 200V 105D 25DIA X40 10MML/S	C74		010-04220-09	CAP CER 2N2 10% 250VAC APPROVED
*C12		021-09560-00	CAP 560UF ELECT 200V 105D 25DIA X40 10MML/S	C75		010-04220-09	CAP CER 2N2 10% 250VAC APPROVED
*C13		024-07100-00	CAP 1M 250VDC 5% POLYPROP.22.5 L/S	C78		020-09820-01	CAP 820M 16V ELEC 10X25MM
*C14		024-07100-00	CAP 1M 250VDC 5% POLYPROP.22.5 L/S	C79		019-05470-00	CAP MONOLITHIC CER 47N 10% 50V X7R
*C15		010-03470-03	CAP 470P T/C B 10% 6KV CER	C80		010-04100-04	CAP CER 1N 10% T/C B 400V
C16		025-07100-01	CAP TANT BEAD 1M 35V	C81		010-04100-04	CAP CER 1N 10% T/C B 400V
C17		011-53470-02	CAP CER AI 470P 10% T/C B 63V	C82		010-04100-04	CAP CER 1N 10% T/C B 400V
C18		011-03680-01	CAP CER 680P 10% N1K5 50/63V	C84		019-05470-00	CAP MONOLITHIC CER 47N 10% 50V X7R
C20		010-04100-04	CAP CER 1N 10% T/C B 400V	C85		011-52330-01	CAP CER AI 33P 5% N150 50/63V
C21		022-55470-10	CAP MYLAR AI 47N 5% 63V POTTED	C86		022-54100-10	CAP MYLAR AI 1N 5% 63V POTTED
C22		022-55470-10	CAP MYLAR AI 47N 5% 63V POTTED	C87		022-54220-10	CAP MYLAR AI 1N 5% 63V POTTED
C23		020-08470-07	CAP ELECT RADL 47M 16V 8X11.5MM HI TEMP	C88		022-55470-10	CAP MYLAR AI 47N 5% 63V POTTED
C24		020-07100-04	CAP ELECT RADL 1M 63V 8X12MM HI TEMP	C89		011-52220-01	CAP CER AI 22P 5% N150 50/63V
C25		025-08100-04	(L) CAP 10M 35V 10% TANT 2.5MM L/S	C90		010-04100-04	CAP CER 1N 10% T/C B 400V
C26		011-54100-01	CAP CER AI 1N 10% T/C B 63V	C91		010-04100-04	CAP CER 1N 10% T/C B 400V
C27		011-54100-01	CAP CER AI 1N 10% T/C B 63V	C95		011-54100-01	CAP CER AI 1N 10% T/C B 63V
C31		011-54100-01	CAP CER AI 1N 10% T/C B 63V	C96		022-56100-10	CAP MYLAR AI 100N 5% 63V POTTED
C32		011-54100-01	CAP CER AI 1N 10% T/C B 63V	C98		025-08100-04	(L) CAP 10M 35V 10% TANT 2.5MM L/S
C33		019-05470-00	CAP MONOLITHIC CER 47N 10% 50V X7R	C99		011-52220-01	CAP CER AI 22P 5% N150 50/63V
C34		025-08100-04	(L) CAP 10M 35V 10% TANT 2.5MM L/S	C100		019-55100-01	CAP MONOLITHIC AI 10N 5% COG 50V
C35		011-54100-01	CAP CER AI 1N 10% T/C B 63V	C101		011-03100-06	CAP CER 100P 5% N750 50/63V
C37		020-19220-04	CAP 2200M ELEC 35V 16X35 L ESR	*C104		011-04100-02	CAP CER 1N0 2.5MM 10% T/C B 50V
C38		019-05470-00	CAP MONOLITHIC CER 47N 10% 50V X7R				
C39		019-05470-00	CAP MONOLITHIC CER 47N 10% 50V X7R	D1		001-00012-30	(S) DIODE 6A6 MR 756 BY214-600 6A/600V
C42		011-54100-01	CAP CER AI 1N 10% T/C B 63V	D2		001-00012-30	(S) DIODE 6A6 MR 756 BY214-600 6A/600V
C43		011-54100-01	CAP CER AI 1N 10% T/C B 63V	D3		001-00012-30	(S) DIODE 6A6 MR 756 BY214-600 6A/600V
C44		025-07100-01	CAP TANT BEAD 1M 35V	D4		001-00012-30	(S) DIODE 6A6 MR 756 BY214-600 6A/600V
C45		011-54100-01	CAP CER AI 1N 10% T/C B 63V	D5		001-50012-05	(S) DIODE AI 1N4531 SI SMALL SIG
C46		011-54100-01	CAP CER AI 1N 10% T/C B 63V	D6		001-50012-05	(S) DIODE AI 1N4531 SI SMALL SIG
C49		019-05470-00	CAP MONOLITHIC CER 47N 10% 50V X7R	D7		001-50012-05	(S) DIODE AI 1N4531 SI SMALL SIG
C50		025-08100-04	(L) CAP 10M 35V 10% TANT 2.5MM L/S	D8		001-50012-05	(S) DIODE AI 1N4531 SI SMALL SIG
C51		010-04100-04	CAP CER 1N 10% T/C B 400V	D11		001-50012-05	(S) DIODE AI 1N4531 SI SMALL SIG
C54		011-54100-01	CAP CER AI 1N 10% T/C B 63V	D12		001-50012-05	(S) DIODE AI 1N4531 SI SMALL SIG
C55		019-05470-00	CAP MONOLITHIC CER 47N 10% 50V X7R	D13		008-00014-73	(S) LED HLMP5050 GREEN RT ANGLE PCB MTG
C56		025-08100-04	(L) CAP 10M 35V 10% TANT 2.5MM L/S	D14		001-00012-23	(S) DIODE BYV26C 1A/400V FAST SWITCH
C57		025-08100-04	(L) CAP 10M 35V 10% TANT 2.5MM L/S	*D15		001-00011-06	(S) DIODE MUR440 ULTRAFast 400V 4A
C59		011-54100-01	CAP CER AI 1N 10% T/C B 63V	*D18		001-00011-06	(S) DIODE MUR440 ULTRAFast 400V 4A
C60		017-15470-01	CAP CER SURFACE BARRIER 47N 20% 50V	D19		001-00012-23	(S) DIODE BYV26C 1A/400V FAST SWITCH
C61		025-08100-04	(L) CAP 10M 35V 10% TANT 2.5MM L/S	D20		001-50012-05	(S) DIODE AI 1N4531 SI SMALL SIG
C62		019-05470-00	CAP MONOLITHIC CER 47N 10% 50V X7R	D21		001-50012-05	(S) DIODE AI 1N4531 SI SMALL SIG
C63		022-57100-02	CAP MYLAR AI 1M 20% 50V POTTED	D22		001-00013-40	(S) DIODE SCHOTTKY BAT85 0.2A/30V
C65		020-09470-07	CAP 470M 16V 20% ELEC VERT 8*20 3.5MM L/S LO-ESR	D23		008-00014-74	(S) LED HLMP5030 RED RT ANGLE PCB MTG
				D24		001-00011-70	(S) DIODE 1N4001 1A/50V





## T808 Mechanical &amp; Miscellaneous Parts (220-01183-05)

IPN	Legend	Description	IPN	Legend	Description
200-00010-35		WIRE T/C 1.5MM/1.4MM For L1 & L6. 35mm each	352-00010-08	15	NUT M3 COLD FORM HEX ST BZ D43 x1, Mains Socket x2, IC2 x1, Fan x4, Mounting Kit x2 (in bag)
201-00051-15		WIRE APPLC 1MM <sup>2</sup> GREEN HI TEMP PVC85 For Earth Lead	352-00010-29	16	NUT M4 NYLOC HEX Handle x2
201-00060-09		WIRE REMIT 0.8MM <sup>2</sup> PVC WHITE For Cut Out Switch on T1	353-00010-10		WASHER M3 FLAT 7MM*0.6MM ST BZ Mounting Kit x2 (in bag)
209-00010-26		TAPE COPPER 19MM * 0.08MM SCOTCH 1181 For taping switch to T1	353-00010-12	17	WASHER M3 SPRING BZ OR Z/C D43 x1, Mains Socket x2, IC2 x1, Fan x4
220-01183-05	1	PCB T807/T808 SMPS 2 OUNCE COPPER	356-00020-06		RECEPTL 6.3MM QUICK CONN FLARED INS For Earth Lead
240-02010-22		SKT MAINS 3PIN FLEX 2M/10A	356-00020-07		RECEPTL M3.5QUICK CONN M3.5 OPEN END For Earth Lead
*240-04020-72		SOCKET HOUSING 2 WAY MTG ULTREX To connect fan to PL-2	356-00020-21		TAB 6.3MM RT ANGLE SPADE CAR QCK CONN PCB Mounted Earth Connector
*240-04020-76		SKT RECEPTACLES WIRE CRIMP ULTREX To connect fan to PL-2	362-00010-13	18	BUSH INSULATING 1.1MM TOP HAT D43 Mounting x1
240-06010-27		BLANKING PLATE 2.5MM GREEN Fitted to SK-8	362-01024-00	19	INSULATOR 54*30 AS PER DRWG A4M2431 Q1/Q2 x1, D43 x1
*258-00010-04	22	FAN 12V 40 x 40 x 20 TUBE AXIAL Mount to rear panel	362-01052-00	20	XSTR CLAMPING BRKT T807/808 A4M2407 Bracing bracket for Q1 & Q2 x1
303-23128-01	2	COVR SIDE A2M2403/2 T807/808 COMP SCRNM	365-00011-54		LABEL WHITE RW 1556/2 90X24MM SPEC AD For outside of box
306-01010-00	3	FERRULE A4M948 HANDLE FXD EQUIP Place on handle x2	365-00013-59		LABEL T807/808 HI VOLT WARNING A4A651
307-02029-00		GUIDE REAR T807/808 A3M2409 Packed in box x2	365-00100-05		LABEL BLANK 50X9MM S/A METLSD POLYES Mounting Kit x1 (in bag) NB/ Label is to be placed over top of screened version on panel if power supply is to be 115 Volts
308-01007-00	4	HANDLE A4M949 FXD EQUIP Front Panel	365-01391-01		LABEL BLNK 30X10.8MM TAMPERMARK VOID Ser No x1, Job No x1, Rev No x1 & Elec Insp x1
308-13088-00		HSINK CLIP ON 14 OR 16 DIP INT CCTS ICs 4, 5 & 6	399-00010-10		RUBBER BAND NO 33
308-13091-00		HSINK PCB MTG TO-220 Heatsink for IC2 mounting to PCB	399-00010-51		BAG PLASTIC 75*100MM For Mounting Kit
311-00010-39		KNOB RED PLASTIC ROUND Pushes on to SW2	400-00020-01		SLEEING 0.7MM SIL RUBBER For Legs of R13A, R47 & R64
316-06399-01	5	PNL FRT COMPL T807 A3M2405/2	400-00020-03		SLEEING 1MM SIL RUBBER For Legs of R3, R11, 79A, R79B, R81 & R82
316-21176-03	6	PNL REAR A3M2427/2 T807 COMPL SCRNM	400-00020-05		SLEEING 1.5MM SIL RUBBER
318-01018-00	7	RAIL CHASSIS T807/808 A3M2404 Attached to PCB x2	400-00020-07		SLEEING 2MM SIL RUBBER Goes over wire for L1 & L6.
319-30030-01	8	SPACER A4M1115 T807/808 Between P.C.B. & Rails x6	410-01081-00		CRTN T800 KIWI REF22860 402X192X66MM
345-00040-06	9	SCREW M3*8MM PAN POZI ST BZ SK-3 x2, Mounting Kit x2 (in bag)	410-01082-00		CRTN 10 T800 KIWI REF24417 423X410X360
345-00040-12		SCREW M3X10MM CSK POZI ST BZ Mounting Kit x6 (in bag)			
345-00040-17	10	SCREW M3*16MM CSK POZI ST BZ D43 x1			
*345-00040-19	21	SCREW M3*25MM PAN POZI ST BZ Fan x4			
345-00040-24	11	SCREW M3X20MM CSK POZI ST BZ Q1/Q2 Bracing Bracket x1			
349-00020-07	12	SCREW 4-40 X 5/16 PAN POZI TAPTITE BLACK Front x4, Rear x4, Cover x4			
349-00020-08	13	SCREW TAPTITE 4-40X3/8IN CSK POZI BZ Covers to rails x16			
349-00020-34	14	SCREW M3*12 PAN POZI TAPTITE BZ P.C.B. to rails x6			

**T808 Mechanical Assembly Exploded View**

***replace A4 pages B8.2.35/B8.2.36 with A3  
pages B8.2.35/B8.2.36, file name 800b83b.100***

T808 Mechanical Assembly Exploded View

***replace A4 pages B8.2.35/B8.2.36 with A3  
pages B8.2.35/B8.2.36, file name 800b83b.100***



## T807/808 Grid Reference Index (IPN 220-01183-05)

**How To Use This Grid Reference Index**

The first digit in the PCB layout reference is a "1" or "2", indicating the top or bottom side layout respectively, and the last two characters give the location of the component on that diagram.

The first digit in the circuit diagram reference is the sheet number, and the last two characters give the location of the component on that sheet.

Device	PCB	Circuit	Device	PCB	Circuit	Device	PCB	Circuit	Device	PCB	Circuit
*C1	1:U11	1-C6	*C72	1:P3	1-M8	IC1	1:G8	1-M4	R20	1:D12	1-M4
*C2	1:U12	1-C5	*C73	1:Q3	1-N8			1-Q3	R24	1:D8	1-K4
*C3	1:T11	1-C6	C74	1:R3	1-N9			1-M0	RV25	1:F8	1-K4
*C4	1:R11	1-D6	C75	1:R2	1-N8	IC2	1:P7	1-D3	R26	1:E8	1-K3
*C5	1:P10	1-D6	C78	1:V3	1-P8	IC3	1:U5	1-G2	R27	1:G6	1-L4
*C5A	1:P10		C79	1:W3	1-Q8			1-G0	R28	1:G6	1-L4
*C6	1:P12	1-D5	C80	1:X2	1-R9			1-D1	R29	1:H6	1-L3
*C6A	1:P12		C81	1:X3	1-R8	IC4	1:Q6	1-L0	R30	1:G7	1-M4
*C9	1:K9	1-F6	C82	1:X4	1-R7	IC5	1:R5	1-M1	R32	1:G6	1-M4
*C10	1:H11	1-G6	C84	1:R7	1-N6			1-N1	R33	1:G7	1-M3
*C11	1:H9	1-F5	C85	1:S4	1-P6			1-L0	R34	1:G7	1-M3
*C12	1:K11	1-G5	C86	1:N4	1-P5	IC6	1:R6	1-M1	R35	1:G8	1-N3
*C13	1:J8	1-H5	C87	1:N5	1-P5			1-N1	R36	1:M6	1-M3
*C14	1:L8	1-H6	C88	1:N5	1-Q5			1-L0	R37	1:M6	1-N2
*C15	1:D3	1-H5	C89	1:N5	1-R5	IC7	1:S6	1-N6	R38	1:M6	1-N2
C16	1:B11	1-K5	C90	1:X3	1-R6	IC8	1:S5	1-P5	R39	1:C10	1-J6
C17	1:C8	1-J4	C91	1:X4	1-R5	*L1	1:X10	1-A6	R40	1:C10	1-K6
C18	1:C10	1-K6	C95	1:T5	1-P7	*L1A	1:X11		R41	1:H7	1-N3
C19	1:D10	1-L6	C96	1:N6	1-J1	L2	1:V11	1-B6	R43	1:C7	1-K6
C20	1:C12	1-K4	C98	1:N7	1-G1	L3	1:S11	1-C6	R44	1:G8	1-Q3
C21	1:D8	1-J3	C99	1:P7	1-K1	L4	1:C12	1-K4	R45	1:D11	1-K6
C22	1:G6	1-L4	C100	2:F9		L5	1:C12	1-K3	R46	1:G7	1-K0
C23	1:F6	1-M4	C101	2:G8		L6	1:W3	1-Q9	R47	1:G6	1-N0
C24	1:F7	1-M3	*C104	2:H7		L7	1:W5	1-D0	R48	1:F7	1-P3
C25	1:N6	1-M2	D1	1:N10	1-F6	L8	1:W5	1-D0	R49	1:N10	1-B2
C26	1:M6	1-M2	D2	1:N9	1-F6	*L9	1:F12		R50	1:V6	1-E2
C27	1:L6	1-N2	D3	1:N8	1-F6	*L10	1:D12		R51	1:W7	1-F2
C31	1:E8	1-Q3	D4	1:M9	1-F6	PL-1	1:D9	1-B0	R52	1:V5	1-G3
C32	1:G8	1-Q3	D5	1:D7	1-J4			1-E3	R53	1:U7	1-F2
C33	1:H8	1-M0	D6	1:D8	1-J4	*PL-2	1:T6	1-H0	R54B	1:U5	1-F2
C34	1:H8	1-N0	D7	1:C8	1-J3	*Q1	1:G12	1-L5	R55	1:W6	1-E1
C35	1:C12	1-Q1	D8	1:C7	1-J3	*Q2	1:E12	1-L4	R56	1:W6	1-F0
C37	1:P9	1-C2	D11	1:C12	1-H2	Q3	1:H6	1-L3	R57	1:W6	1-F1
C38	1:N7	1-D2	D12	1:B11	1-K5	Q4	1:M6	1-N2	R58	1:W6	1-F0
C39	1:P7	1-E2	D13	1:A11	1-K5	Q6	1:U6	1-H0	R59	1:V5	1-G1
C42	1:W7	1-E2	D14	1:G11	1-L6	Q7	1:B11	1-J2	R60	1:F7	1-P3
C43	1:V5	1-F2	*D15	1:G12	1-L6	Q8	1:T5	1-P7	R61	1:G8	1-Q3
C44	1:U5	1-F2	*D18	1:E12	1-L5	Q9	1:H5	1-K8	R62	1:U6	1-G0
C45	1:W6	1-F1	D19	1:E11	1-L4	Q10	1:B12	1-R2	R63	1:U6	1-H0
C46	1:W6	1-F0	D20	1:H7	1-N4	Q11	1:P6	1-H1	R64	1:V6	1-D1
C49	1:U6	1-D1	D21	1:H7	1-P4	Q12	1:P6	1-H1	R65	1:B11	1-J3
C50	1:V6	1-E1	D22	1:N6	1-M3	Q13	1:M7	1-J1	R66	1:B11	1-J3
C51	1:W5	1-D0	D23	1:A12	1-R2	R1	1:X9	1-B5	R67	1:C11	1-J2
C54	1:P5	1-K0	D24	1:Q8	1-C2	R2	1:N11	1-E6	R68	1:C12	1-Q1
C55	1:Q5	1-K2	D25	1:P8	1-C2	R3	1:U10	1-E6	R69	1:B12	1-R2
C56	1:P4	1-K2	D26	1:N8	1-C2	R4	1:M8	1-G6	R70	1:P5	1-L2
C57	1:Q5	1-K2	D27	1:P8	1-C2	R5	1:L10	1-G6	R71	1:P6	1-K1
C59	1:P6	1-K1	D30	1:U7	1-F3	R6	1:L10	1-G5	R72	1:P6	1-K1
C60	1:Q5	1-M2	D31	1:V6	1-F2	R7	1:M10	1-G5	R73	1:P4	1-K0
C61	1:Q7	1-K0	D32	1:A11	1-J2	R8	1:L11	1-G5	R74	1:Q6	1-M2
C62	1:Q6	1-K0	D36	1:Q6	1-L1	R9	1:G10	1-H5	R75	1:Q6	1-M2
C63	1:H7	1-N1	D37	1:Q6	1-M1	R11	1:D2	1-H6	R76	1:G8	1-Q2
C65	1:G5	1-K8	D38	1:C11	1-J6	*R12	1:C7	1-J4	R79A	1:G2	1-H9
C66	1:H3	1-H8	D41	1:G4	1-J8	R13A	1:B10	1-K5	R79B	1:G2	1-J9
C67	1:F3	1-J8	D43	1:G2	1-H9	R13B	1:B11	1-K5	R80	1:W8	1-J9
*C68	1:N2	1-L8			1-H9	R14	1:C11	1-K5	R80A	1:F4	1-J8
*C69	1:P2	1-L8	*FAN	1:Z8	1-J0	*R17	1:F12	1-M5	R80B	1:G5	1-K8
*C70	1:Q2	1-M8	*F1	1:W10	1-B6	R18	1:F12	1-L5	*R81	1:K5	1-K9
*C71	1:N3	1-M8	HS	1:P7		*R19	1:D12	1-M5	RV81	1:F7	1-P3

<u>Device</u>	<u>PCB</u>	<u>Circuit</u>	<u>Device</u>	<u>PCB</u>	<u>Circuit</u>	<u>Device</u>	<u>PCB</u>	<u>Circuit</u>	<u>Device</u>	<u>PCB</u>	<u>Circuit</u>
*R82	1:K5	1-K9									
R83	1:U5	1-Q8									
R84	1:T5	1-Q8									
R85	1:W2	1-R9									
R86	1:T4	1-N7									
R87	1:T4	1-P6									
R88	1:S5	1-P6									
R89	1:T4	1-Q6									
R90	1:S4	1-P6									
R91	1:N4	1-N5									
RV92	1:S5	1-Q5									
R93	1:T5	1-Q5									
R94	1:P5	1-Q5									
R95	1:N5	1-Q4									
R96	1:N5	1-R5									
R98	1:W4	1-P7									
R99	1:W4	1-P7									
R100	1:N6	1-H1									
R101	1:Q6	1-H1									
R102	1:N6	1-J1									
R103	1:N5	1-J1									
R104	1:N5	1-J1									
R105	1:M7	1-J1									
*R106	1:H7										
*R107	1:H7										
RLY1	1:V8	1-J9									
		1-F6									
SW1	1:N12	1-E5									
		1-A3									
SW2	1:C9	1-J3									
SK-1		1-B0									
		1-E3									
SK-2		1-H0									
SK-3	1:X10	1-A4									
SK-4	1:X2	1-R9									
SK-5	1:X3	1-R8									
SK-6	1:Y3	1-R6									
SK-7	1:Y3	1-R6									
SK-8	1:Y4	1-R7									
T1	1:C5	1-J5									
T2	1:B8	1-J5									
T3	1:F10	1-M4									
T4	1:S8	1-B2									
*T5	1:K3	1-K8									
T6	1:T3	1-P8									
TAB-1	1:Y8	1-A7									
TC1		1-E3									
TP1	1:N7	1-G6									
TP2	1:G10	1-G5									
TP3	1:D8	1-J4									
TP4	1:L7	1-B0									
TP5	1:C9	1-E3									
TP6	1:K7	1-P1									
TP7	1:J7	1-P1									

## T807 Parts List (IPN 220-01183-07)

### How To Use This Parts List

The components listed in this parts list are divided into two main types: those with a circuit reference (e.g. C2, D1, R121, etc) and those without (miscellaneous and mechanical). Static sensitive devices are prefixed with (S).

Those with a circuit reference are grouped by component type in numerical order. Each component entry comprises three or four columns: the circuit reference, variant number (if applicable), IPN and description. A number in the variant column indicates that this component is fitted only to that variant.

The miscellaneous and mechanical section lists the parts in IPN order and where possible the legend indicates their position on the exploded view.

### Parts List Amendments

C104	Changed from 011-54100-01 (63V) to 011-04100-02 (50V) due to new board design (97/04-7072).
R17 & R19	Two ferrite beads to be placed (065-00010-04) - not previously included (96/10-7175).
R83 & R84	Ferrite beads to be placed (065-00010-04) - not previously included (96/10-7175).
R99	Part 030-54100-20 not used (97/04-7091).

Important mechanical assembly changes to this issue are as follows:

307-02044-00	Add Series II guide rail.
308-01007-01	Add Series II handle.
316-06623-00	Add Series II front panel.
316-21176-02	Rear panel changed from 316-21176-02 to -03 - incorrect IPN in previous issue (96/10-7178).
319-01189-01	Filter shield changed from 319-01189-01 to -02 - new filter shield (750018).
349-00020-07	Delete screw 4-40 x 5/16 Pan Pozi Taptite black - not required in Series II.

Ref	Var	IPN	Description	Ref	Var	IPN	Description
C1		010-04470-09	CAP CERAMIC 4N7 +-20% 250VAC APPROVED	D13		008-00014-73	(S) LED HLMF0500 GREEN RT ANGLE PCB MTG
C2		010-04470-09	CAP CERAMIC 4N7 +-20% 250VAC APPROVED	D14		001-00012-23	(S) DIODE BYV26C 1A/400V FAST SWITCH
C3		022-06680-04	CAP MYLAR 680N + 20% 250VAC APPROVED	*D15		001-00012-27	(S) DIODE BYV28-200 3.5A/200V FAST SWITCH
C4		022-06680-04	CAP MYLAR 680N + 20% 250VAC APPROVED	*D18		001-00012-27	(S) DIODE BYV28-200 3.5A/200V FAST SWITCH
C5		010-04470-09	CAP CERAMIC 4N7 +-20% 250VAC APPROVED	D19		001-00012-23	(S) DIODE BYV26C 1A/400V FAST SWITCH
C5A		010-04470-09	CAP CERAMIC 4N7 +-20% 250VAC APPROVED	D20		001-50012-05	(S) DIODE AI 1N4531 SI SMALL SIG
C6		010-04470-09	CAP CERAMIC 4N7 +-20% 250VAC APPROVED	D21		001-50012-05	(S) DIODE AI 1N4531 SI SMALL SIG
C6A		010-04470-09	CAP CERAMIC 4N7 +-20% 250VAC APPROVED	D22		001-00013-40	(S) DIODE SCHOTTKY BAT85 0.2A/30V
*C9		021-09390-00	CAP 390UF ELECT 200V 105D 25DIAX40 10MMLS	D23		008-00014-74	(S) LED HLMF0500 RED RT ANGLE PCB MTG
*C10		021-09390-00	CAP 390UF ELECT 200V 105D 25DIAX40 10MMLS	D24		001-00011-70	(S) DIODE 1N4001 1A/50V
*C11		021-09390-00	CAP 390UF ELECT 200V 105D 25DIAX40 10MMLS	D25		001-00011-70	(S) DIODE 1N4001 1A/50V
*C12		021-09390-00	CAP 390UF ELECT 200V 105D 25DIAX40 10MMLS	D26		001-00011-70	(S) DIODE 1N4001 1A/50V
*C13		024-06680-08	CAP POLYPR AXIAL 680N 20% 250VDC	D27		001-00011-70	(S) DIODE 1N4001 1A/50V
*C14		024-06680-08	CAP POLYPR AXIAL 680N 20% 250VDC	D30		001-00011-70	(S) DIODE 1N4001 1A/50V
*C15		010-03220-03	CAP CER 220P 10% T/C B 6KV	D31		001-00015-19	(S) DIODE ZENER 5V6 0.4W 2% BZX79/B5V6
C16		025-07100-01	CAP TANT BEAD 1M 35V	D32		008-00014-74	(S) LED HLMF0500 RED RT ANGLE PCB MTG
C17		011-53470-02	CAP CER AI 470P 10% T/C B 63V	D36		001-50012-05	(S) DIODE AI 1N4531 SI SMALL SIG
C18		011-03680-01	CAP CER 680P 10% N1K5 50/63V	D37		001-50012-05	(S) DIODE AI 1N4531 SI SMALL SIG
C19		019-55100-01	CAP MONOLITHIC AI 10N 5% COG 50V	D38		001-50012-05	(S) DIODE AI 1N4531 SI SMALL SIG
C20		010-04100-04	CAP CER 1N 10% T/C B 400V	D41		001-50012-05	(S) DIODE AI 1N4531 SI SMALL SIG
C21		022-55470-10	CAP MYLAR AI 47N 5% 63V POTTED	D43		001-00011-45	(S) DIODE DUAL 30A/90V 30CPQ90
C22		022-55470-10	CAP MYLAR AI 47N 5% 63V POTTED				
C23		020-08470-07	CAP ELECT RADL 47M 16V 8X11.5MM HI TEMP	*F1		265-00010-51	FUSE 5.0A 250V SLOW BLOW 5X20
C24		020-07100-04	CAP ELECT RADL 1M 63V 8X12MM HI TEMP	FC1		340-00010-07	FUSE CLIP PCB MTG 5MM FUSE
C25		025-08100-03	CAP 10M 35V 20% TANT 5MM L/S	FC2		340-00010-07	FUSE CLIP PCB MTG 5MM FUSE
C26		011-54100-01	CAP CER AI 1N 10% T/C B 63V	IC1		002-00012-40	(S) IC 358 DUAL OP AMP
C27		011-54100-01	CAP CER AI 1N 10% T/C B 63V	IC2		002-00010-81	(S) IC 7815 +15V 1AMP TO -220 3PIN
C31		011-54100-01	CAP CER AI 1N 10% T/C B 63V	IC3		002-00012-40	(S) IC 358 DUAL OP AMP
C32		011-54100-01	CAP CER AI 1N 10% T/C B 63V	IC4		002-00016-61	(S) IC 3525A SMPS CTRL
C33		019-05470-00	CAP MONOLITHIC CER 47N 10% 50V X7R	IC5		002-00010-75	(S) IC TSC426 DRIVER INVERTING MOSFET 8PIN
C34		025-08100-03	CAP 10M 35V 20% TANT 5MM L/S	IC6		002-00010-75	(S) IC TSC426 DRIVER INVERTING MOSFET 8PIN
C35		011-54100-01	CAP CER AI 1N 10% T/C B 63V	IC7		002-00020-58	(S) IC CNX62A OPTOCOUPLER 250VAC APPROVD
C37		020-19220-04	CAP 2200M ELEC 35V 16X35 L ESR	IC8		002-00014-15	(S) IC TL431 SHUNT REG TO-92
C38		019-05470-00	CAP MONOLITHIC CER 47N 10% 50V X7R				
C39		019-05470-00	CAP MONOLITHIC CER 47N 10% 50V X7R	L1		056-00010-50	CHOKO 16UH +-20% DIFF MODE
C42		011-54100-01	CAP CER AI 1N 10% T/C B 63V	L1A		056-00010-50	CHOKO 16UH +-20% DIFF MODE
C43		011-54100-01	CAP CER AI 1N 10% T/C B 63V	L2		056-00010-36	CHOKO FLTR 0.5MH COMM MODE
C44		025-07100-01	CAP TANT BEAD 1M 35V	L3		056-00021-20	IND FXD 2MH 5AMP TOROIDAL
C45		011-54100-01	CAP CER AI 1N 10% T/C B 63V	L4		065-00010-11	BEAD FERRITE 4S3 3*1*4MM RED
C46		011-54100-01	CAP CER AI 1N 10% T/C B 63V	L5		065-00010-11	BEAD FERRITE 4S3 3*1*4MM RED
C49		019-05470-00	CAP MONOLITHIC CER 47N 10% 50V X7R	L6		069-00010-29	TOROID CORE FERRITE TN14/9/5 4A11 x5
C50		025-08100-03	CAP 10M 35V 20% TANT 5MM L/S	L7		065-00010-11	BEAD FERRITE 4S3 3*1*4MM RED
C51		010-04100-04	CAP CER 1N 10% T/C B 400V	L8		065-00010-11	BEAD FERRITE 4S3 3*1*4MM RED
C54		011-54100-01	CAP CER AI 1N 10% T/C B 63V	L9		065-00010-11	BEAD FERRITE 4S3 3*1*4MM RED
C55		019-05470-00	CAP MONOLITHIC CER 47N 10% 50V X7R	L8		065-00010-04	BEAD FERRITE F8 4X2X5MM
C56		025-08100-03	CAP 10M 35V 20% TANT 5MM L/S	L10		065-00010-04	BEAD FERRITE F8 4X2X5MM
C57		025-08100-03	CAP 10M 35V 20% TANT 5MM L/S	L12		065-00010-08	BEAD FERRITE 4S3 3*0.7*10MM RED
C59		011-54100-01	CAP CER AI 1N 10% T/C B 63V	L13		065-00010-08	BEAD FERRITE 4S3 3*0.7*10MM RED
C60		017-15470-01	CAP CER SURFACE BARRIER 47N 20% 50V	L14		065-00010-08	BEAD FERRITE 4S3 3*0.7*10MM RED
C61		025-08100-03	CAP 10M 35V 20% TANT 5MM L/S	L15		065-00010-08	BEAD FERRITE 4S3 3*0.7*10MM RED
C62		019-05470-00	CAP MONOLITHIC CER 47N 10% 50V X7R				
C63		022-57100-02	CAP MYLAR AI 1M 20% 50V POTTED				
C65		020-09470-07	CAP 470M 16V 20% ELEC VERT 8*20 3.5MM L/S LO-ESR				
C66		024-14470-01	CAP METAL POLYPR RADL 4N7 10% 400VAC				
C67		024-14470-01	CAP METAL POLYPR RADL 4N7 10% 400VAC				
*C68		020-19220-02	CAP ELECT RAD 2200M 16V 12.5X30MM LO ESR				
*C69		020-19220-02	CAP ELECT RAD 2200M 16V 12.5X30MM LO ESR				
*C70		020-19220-02	CAP ELECT RAD 2200M 16V 12.5X30MM LO ESR				
*C71		020-19220-02	CAP ELECT RAD 2200M 16V 12.5X30MM LO ESR				
*C72		020-19220-02	CAP ELECT RAD 2200M 16V 12.5X30MM LO ESR				
*C73		020-19220-02	CAP ELECT RAD 2200M 16V 12.5X30MM LO ESR	*Q1		000-00012-63	(S) XSTR MTP4N50 PWR MOSFET 500V TO220
C74		022-05470-04	CAP MYLAR 47N +-20% 250VAC APPROVED	*Q2		000-00012-63	(S) XSTR MTP4N50 PWR MOSFET 500V TO220
C75		022-05470-04	CAP MYLAR 47N +-20% 250VAC APPROVED	Q3		000-50011-30	(S) XSTR AI BC557B PNP TO-92 AF S/SIG
C78		020-09820-01	CAP 820M 16V ELECT 10X25MM	Q4		000-50011-10	(S) XSTR AI BC547B NPN TO-92 AF S/SIG
C79		015-25100-08	CAP CER 0805 CHIP 10N 10% X7R 50V	Q6		000-00010-66	(S) XSTR BC337 NPN AF PWR TO92
C80		010-05100-09	CAP CER 10N +-20% 250VAC RATED	Q7		000-50011-30	(S) XSTR AI BC557B PNP TO-92 AF S/SIG
C81		010-05100-09	CAP CER 10N +-20% 250VAC RATED	Q8		000-50011-30	(S) XSTR AI BC557B PNP TO-92 AF S/SIG
C82		010-04100-04	CAP CER 1N 10% T/C B 400V	Q9		000-00010-66	(S) XSTR BC337 NPN AF PWR TO92
C83		015-06100-08	CAP CER 1206 CHIP 100N 10% X7R 50V	Q10		000-50011-10	(S) XSTR AI BC547B NPN TO-92 AF S/SIG
C84		019-05470-00	CAP MONOLITHIC CER 47N 10% 50V X7R	Q11		000-50011-10	(S) XSTR AI BC547B NPN TO-92 AF S/SIG
C85		011-52330-01	CAP CER AI 33P 5% N150 50/63V	Q12		000-50011-10	(S) XSTR AI BC547B NPN TO-92 AF S/SIG
C86		022-54100-10	CAP MYLAR AI 1N 5% 63V POTTED	Q13		000-50011-10	(S) XSTR AI BC547B NPN TO-92 AF S/SIG
C87		022-54220-10	CAP MYLAR AI 2N2 5% 63V POTTED				
C88		022-55470-10	CAP MYLAR AI 47N 5% 63V POTTED	R1		030-08100-31	RES M/F 10M 3.5KV VR37 10*4MM
C89		011-52220-01	CAP CER AI 22P 5% N150 50/63V	R2		049-00275-40	VARISTOR 275V AC 140JOULES 20MM DIA.
C90		010-04100-04	CAP CER 1N 10% T/C B 400V	R3		035-02100-93	RES WIRE WOUND 10E 5W 19X8MM
C91		010-04100-04	CAP CER 1N 10% T/C B 400V	R4		032-35470-00	RES M/F PWR 47K 5% 1W 12X4.5MM
C92		010-04220-09	CAP CER 2N2 10% 250VAC APPROVED	R5		030-56270-20	RES FILM AI 270K 5% 0.4W 4X1.6MM
C93		010-04220-09	CAP CER 2N2 10% 250VAC APPROVED	R6		030-56390-20	RES FILM AI 390K 5% 0.4W 4X1.6MM
C95		011-54100-01	CAP CER AI 1N 10% T/C B 63V	R7		032-35470-00	RES M/F PWR 47K 5% 1W 12X4.5MM
C96		022-56100-10	CAP MYLAR AI 100N 5% 63V POTTED	R8		030-55680-20	RES FILM AI 68K 5% 0.4W 4X1.6MM
C98		025-08100-03	CAP 10M 35V 20% TANT 5MM L/S	R9		030-55470-20	RES FILM AI 47K 5% 0.4W 4X1.6MM
C99		011-52220-01	CAP CER AI 22P 5% N150 50/63V	R11		032-33100-02	RES M/F PWR 100E 5% 6W 33X9MM
C100		011-03100-06	CAP CER 100P 5% N750 50/63V	*R12		030-53180-20	RES FILM AI 180E 5% 0.4W 4X1.6MM
C102		010-03220-09	CAP CER 220P +-10% 250 VAC APPROVED	R13A		030-52680-20	RES FILM AI 68E 5% 0.4W 4X1.6MM
C104		011-54100-01	CAP CER AI 1N 10% T/C B 63V	R13B		030-54150-20	RES FILM AI 1K5 5% 0.4W 4X1.6MM
				R14		030-54150-20	RES FILM AI 1K5 5% 0.4W 4X1.6MM
				R17		030-52220-20	RES FILM AI 22E 5% 0.4W 4X1.6MM
D1		001-00012-30	(S) DIODE 6A6 MR 756 BY214-600 6A/600V	R18		030-54120-20	RES FILM AI 1K2 5% 0.4W 4X1.6MM
D2		001-00012-30	(S) DIODE 6A6 MR 756 BY214-600 6A/600V	R19		030-52220-20	RES FILM AI 22E 5% 0.4W 4X1.6MM
D3		001-00012-30	(S) DIODE 6A6 MR 756 BY214-600 6A/600V	R20		030-54120-20	RES FILM AI 1K2 5% 0.4W 4X1.6MM
D4		001-00012-30	(S) DIODE 6A6 MR 756 BY214-600 6A/600V	R24		030-54120-20	RES FILM AI 1K2 5% 0.4W 4X1.6MM
D5		001-50012-05	(S) DIODE AI 1N4531 SI SMALL SIG	RV25		042-03470-06	RES PRESET 470E CARBON 6MM FLAT
D6		001-50012-05	(S) DIODE AI 1N4531 SI SMALL SIG	R26		030-53680-20	RES FILM AI 680E 5% 0.4W 4X1.6MM
D7		001-50012-05	(S) DIODE AI 1N4531 SI SMALL SIG	R27		030-54180-20	RES FILM AI 1K8 5% 0.4W 4X1.6MM
D8		001-50012-05	(S) DIODE AI 1N4531 SI SMALL SIG	R28		030-53820-20	RES FILM AI 820E 5% 0.4W 4X1.6MM
D11		001-50012-05	(S) DIODE AI 1N4531 SI SMALL SIG	R29		030-54270-20	RES FILM AI 2K7 5% 0.4W 4X1.6MM
D12		001-50012-05	(S) DIODE AI 1N4531 SI SMALL SIG				

**Note:** Fit L4 & L5 On Leads Of C20  
 Fit L7 & L8 On Leads Of C51  
 Fit L9 Over Body Of R17  
 Fit L10 Over Body Of R19  
 Fit L12 & L13 On Leads Of R83  
 Fit L14 & L15 On Leads Of R84

Ref	Var	IPN	Description	Ref	Var	IPN	Description
R30		030-55100-20	RES FILM AI 10K 5% 0.4W 4X1.6MM				
R32		030-56100-20	RES FILM AI 100K 5% 0.4W 4X1.6MM				
R33		030-54100-20	RES FILM AI 1K 5% 0.4W 4X1.6MM				
R34		030-55100-20	RES FILM AI 10K 5% 0.4W 4X1.6MM				
R35		030-55100-20	RES FILM AI 10K 5% 0.4W 4X1.6MM				
R36		030-55150-20	RES FILM AI 15K 5% 0.4W 4X1.6MM				
R37		030-57100-20	RES FILM AI 1M 5% 0.4W 4X1.6MM				
R38		030-55100-20	RES FILM AI 10K 5% 0.4W 4X1.6MM				
R39		030-54390-20	RES FILM AI 3K9 5% 0.4W 4X1.6MM				
R40		030-54820-20	RES FILM AI 8K2 5% 0.4W 4X1.6MM				
R41		030-54680-20	RES FILM AI 6K8 5% 0.4W 4X1.6MM				
R43		030-55470-20	RES FILM AI 47K 5% 0.4W 4X1.6MM				
R44		030-55100-20	RES FILM AI 10K 5% 0.4W 4X1.6MM				
R45		030-56100-20	RES FILM AI 100K 5% 0.4W 4X1.6MM				
R46		030-55100-20	RES FILM AI 10K 5% 0.4W 4X1.6MM				
R47		030-52220-20	RES FILM AI 22E 5% 0.4W 4X1.6MM				
R48		030-55150-20	RES FILM AI 15K 5% 0.4W 4X1.6MM				
R49		049-00140-10	VARISTOR 140VRMS 180VDC 42 JOULES				
R50		030-54220-20	RES FILM AI 2K2 5% 0.4W 4X1.6MM				
R51		030-55100-20	RES FILM AI 10K 5% 0.4W 4X1.6MM				
R52		030-56180-20	RES FILM AI 180K 5% 0.4W 4X1.6MM				
R53		030-55330-20	RES FILM AI 33K 5% 0.4W 4X1.6MM				
R54B		030-55330-20	RES FILM AI 33K 5% 0.4W 4X1.6MM				
R55		045-05100-01	RES NTC 10K 5% 5MM DISC				
R56		030-55100-20	RES FILM AI 10K 5% 0.4W 4X1.6MM				
R57		030-55270-20	RES FILM AI 27K 5% 0.4W 4X1.6MM				
R58		030-55100-20	RES FILM AI 10K 5% 0.4W 4X1.6MM				
R59		030-57100-20	RES FILM AI 1M 5% 0.4W 4X1.6MM				
R60		030-55100-20	RES FILM AI 10K 5% 0.4W 4X1.6MM				
R61		030-57100-20	RES FILM AI 1M 5% 0.4W 4X1.6MM				
R62		030-54680-20	RES FILM AI 6K8 5% 0.4W 4X1.6MM				
R63		030-52330-20	RES FILM AI 33E 5% 0.4W 4X1.6MM				
R64		030-52220-20	RES FILM AI 22E 5% 0.4W 4X1.6MM				
R65		030-54150-20	RES FILM AI 1K5 5% 0.4W 4X1.6MM				
R66		030-54150-20	RES FILM AI 1K5 5% 0.4W 4X1.6MM				
R67		030-55100-20	RES FILM AI 10K 5% 0.4W 4X1.6MM				
R68		030-56100-20	RES FILM AI 100K 5% 0.4W 4X1.6MM				
R69		030-53680-20	RES FILM AI 680E 5% 0.4W 4X1.6MM				
R70		030-53270-20	RES FILM AI 270E 5% 0.4W 4X1.6MM				
R71		030-54330-20	RES FILM AI 3K3 5% 0.4W 4X1.6MM				
R72		030-52100-20	RES FILM AI 10E 5% 0.4W 4X1.6MM				
R73		030-55100-20	RES FILM AI 10K 5% 0.4W 4X1.6MM				
R74		030-54470-20	RES FILM AI 4K7 5% 0.4W 4X1.6MM				
R75		030-54470-20	RES FILM AI 4K7 5% 0.4W 4X1.6MM				
R76		030-54680-20	RES FILM AI 6K8 5% 0.4W 4X1.6MM				
R79A		032-32100-01	RES M/F PWR 10E 2.5W 17X5MM				
R79B		032-32100-01	RES M/F PWR 10E 2.5W 17X5MM				
R80		030-54100-20	RES FILM AI 1K 5% 0.4W 4X1.6MM				
R80A		030-52100-20	RES FILM AI 10E 5% 0.4W 4X1.6MM				
R80B		030-54180-20	RES FILM AI 1K8 5% 0.4W 4X1.6MM				
*R81		032-33150-01	RES M/F PWR 150E 5% 2.5W 17X5MM				
RV81		042-05100-06	RES PRESET 10K CARBON 6MM FLAT				
*R82		032-33150-01	RES M/F PWR 150E 5% 2.5W 17X5MM				
R83		030-52220-20	RES FILM AI 22E 5% 0.4W 4X1.6MM				
R84		030-52220-20	RES FILM AI 22E 5% 0.4W 4X1.6MM				
R85		030-08100-31	RES M/F 10M 3.5KV VR37 10*4MM				
R86		030-55470-20	RES FILM AI 47K 5% 0.4W 4X1.6MM				
R87		030-53100-20	RES FILM AI 100E 5% 0.4W 4X1.6MM				
R88		030-54100-20	RES FILM AI 1K 5% 0.4W 4X1.6MM				
R89		030-54470-20	RES FILM AI 4K7 5% 0.4W 4X1.6MM				
R90		030-55470-20	RES FILM AI 47K 5% 0.4W 4X1.6MM				
R91		030-54100-20	RES FILM AI 1K 5% 0.4W 4X1.6MM				
RV92		042-03470-06	RES PRESET 470E CARBON 6MM FLAT				
R93		030-53820-20	RES FILM AI 820E 5% 0.4W 4X1.6MM				
R94		030-54120-20	RES FILM AI 1K2 5% 0.4W 4X1.6MM				
R95		030-55680-20	RES FILM AI 68K 5% 0.4W 4X1.6MM				
R96		030-54680-20	RES FILM AI 6K8 5% 0.4W 4X1.6MM				
R98		030-55100-20	RES FILM AI 10K 5% 0.4W 4X1.6MM				
R99		030-54100-20	RES FILM AI 1K 5% 0.4W 4X1.6MM				
R100		030-55560-20	RES FILM AI 56K 5% 0.4W 4X1.6MM				
R101		030-55560-20	RES FILM AI 56K 5% 0.4W 4X1.6MM				
R102		030-56470-20	RES FILM AI 470K 5% 0.4W 4X1.6MM				
R103		030-55560-20	RES FILM AI 56K 5% 0.4W 4X1.6MM				
R104		030-55100-20	RES FILM AI 10K 5% 0.4W 4X1.6MM				
R105		030-54100-20	RES FILM AI 1K 5% 0.4W 4X1.6MM				
R106		030-53100-20	RES FILM AI 100E 5% 0.4W 4X1.6MM				
R107		030-53100-20	RES FILM AI 100E 5% 0.4W 4X1.6MM				
RLY1		237-00010-30	RELAY 12V COIL 240V 10A SPDT				
SW1		233-00010-07	SWITCH DPDT 115/230V 6PIN				
SW2		232-00020-28	PUSH SWITCH PCB MTG				
SK-3		240-00010-23	PLUG 3 PIN 10AMP 250V PCB MTG				
SK-4		240-04030-06	TRMNL BLOCK 1WAY PC MT PHOENIX				
SK-5		240-04030-06	TRMNL BLOCK 1WAY PC MT PHOENIX				
SK-6		240-04030-07	TERML BLK PCB MTG 1WAY FRT 2.5H/SA10				
SK-7		240-04030-07	TERML BLK PCB MTG 1WAY FRT 2.5H/SA10				
SK-8		240-04030-07	TERML BLK PCB MTG 1WAY FRT 2.5H/SA10				
T1		053-00010-58	XFMR T4073 T807/808 SWITCHING				
T2		053-00010-59	XFMR T4074 T807/808 CURRENT SENSE				
T3		053-01060-02	XFMR T4075 T807/808 MOSFET DRIVE				
T4		053-00010-63	XFMR T4079 MAINS 5VA 18V				
*T5		056-00010-39	CHOKO T4072 T807 DIFFNL MODE ETD39				
T6		056-00010-38	CHOKO T4071 T807-808 DIFFNL MODE				
TC1		239-00010-06	SW THERM PEPI 100C BARE TERML.C/W SLEEVE				

## T807 Mechanical & Miscellaneous Parts (220-01183-07)

IPN	Legend	Description	IPN	Legend	Description
200-00010-35		WIRE T/C 1.5MM/1.4MM For L6. 35mm	352-00010-29	16	NUT M4 NYLOC HEX Handle x2
201-00051-15		WIRE APPLC 1MM <sup>2</sup> GREEN HI TEMP PVC85 For Earth Lead	353-00010-10		WASHER M3 FLAT 7MM*0.6MM ST BZ Mounting Kit x2 (in bag)
201-00060-09		WIRE REMIT 0.8MM <sup>2</sup> PVC WHITE For Cut Out Switch on T1	353-00010-12	17	WASHER M3 SPRING BZ OR Z/C D43 x1, Mains Socket x2, IC2 x1
209-00010-26		TAPE COPPER 19MM * 0.08MM SCOTCH 1181 For taping switch to T1	356-00020-06		RECEPTL 6.3MM QUICK CONN FLARED INS For Earth Lead
220-01183-07	1	PCB T807/T808 SMPS 2 OUNCE COPPER	356-00020-07		RECEPTL M3.5QUICK CONN M3.5 OPEN END For Earth Lead
240-02010-22		SKT MAINS 3PIN FLEX 2M/10A	356-00020-21		TAB 6.3MM RT ANGLE SPADE CAR QCK CONN PCB Mounted Earth Connector
240-06010-27		BLANKING PLATE 2.5MM GREEN Fitted to SK-8	362-00010-13	18	BUSH INSULATING 1.1MM TOP HAT D43 Mounting x1
302-05228-01		BRACKET TRANSFORMER MTG T807/808 T4 x1	362-01024-00	19	INSULATOR 54*30 AS PER DRWG A4M2431 Q1/Q2 x1, D43 x1
303-23128-02	2	COVR SIDE A2M2403/2 T807/808 COMP SCRNM	362-01052-00	20	XSTR CLAMPING BRKT T807/808 A4M2407 Bracing bracket for Q1 & Q2 x1
306-01010-00	3	FERRULE A4M948 HANDLE FXD EQUIP Place on Handle x2	365-00011-54		LABEL WHITE RW 1556/2 90X24MM SPEC AD For outside of box
307-02029-00		GUIDE REAR T807/808 A3M2409 Packed in box x2	365-00013-59		LABEL T807/808 HI VOLT WARNING A4A651
308-01007-00	4	HANDLE A4M949 FXD EQUIP Front Panel	365-00100-05		LABEL BLANK 50X9MM S/A METLSD POLYES Mounting Kit x1 (in bag) NB/ Label is to be placed over top of screened version on panel if power supply is to be 115 Volts
308-13088-00		HSINK CLIP ON 14 OR 16 DIP INT CCTS ICs 4, 5 & 6	365-01391-01		LABEL BLNK 30X10.8MM TAMPERMARK VOID Ser No x1, Job No x1, Rev No x1 & Elec Insp x1
308-13091-00		HSINK PCB MTG TO-220 IC2 mounting to PCB	365-01500-00		LABEL CE CONFORMITY 12*24MM
311-00010-39		KNOB RED PLASTIC ROUND Pushes on to SW2	369-00020-52		TAPE ELECT INSULATION UL APPRVD 130°C For T4
316-06398-01	5	PNL FRT COMPL T807 A3M2405/2	399-00010-10		RUBBER BAND NO 33
316-21177-02	6	PNL REAR A3M2427/2 T807 COMPL SCRNM	399-00010-51		BAG PLASTIC 75*100MM For Mounting Kit
318-01018-00	7	RAIL CHASSIS T807/808 A3M2404 Attached to PCB x2	400-00020-01		SLEEVING 0.7MM SIL RUBBER For Legs of R13A, R47 & R64
319-01189-01		SHIELD T807/808 MAINS FILTER Fitted to underside of board across output	400-00020-03		SLEEVING 1MM SIL RUBBER For Legs of R3, R11, 79A, R79B, R81 & R82
319-30030-01	8	SPACER A4M1115 T807/808 Between P.C.B. & Rails x6	400-00020-05		SLEEVING 1.5MM SIL RUBBER
319-40012-00		EARTH STRAP DC T807/808 Fitted to underside of board across input	400-00020-07		SLEEVING 2MM SIL RUBBER Goes over wire on L6.
345-00040-06	9	SCREW M3*8MM PAN POZI ST BZ SK-3 x2, Mounting Kit x2 (in bag)	410-01081-00		CRTN T800 KIWI REF22860 402X192X66MM
345-00040-12		SCREW M3X10MM CSK POZI ST BZ Mounting Kit x6 (in bag)	410-01082-00		CRTN 10 T800 KIWI REF24417 423X410X360
345-00040-17	10	SCREW M3*16MM CSK POZI ST BZ D43 x1			
345-00040-24	11	SCREW M3X20MM CSK POZI ST BZ Q1/Q2 Bracing Bracket x1			
349-00020-07	12	SCREW 4-40 X 5/16 PAN POZI TAPTITE BLACK Front x4, Rear x4, Cover x4			
349-00020-08	13	SCREW TAPTITE 4-40X3/8IN CSK POZI BZ Covers to rails x16			
349-00020-34	14	SCREW M3*12 PAN POZI TAPTITE BZ P.C.B. to rails x6			
352-00010-08	15	NUT M3 COLD FORM HEX ST BZ D43 x1, Mains Socket x2, IC2 x1, Mounting Kit x2 (in bag)			

Replace pages b8.2.47/.48 with A3 foldout T807 Mechanical Assembly in file 800b84a.100





## T808 Parts List (IPN 220-01183-07)

### How To Use This Parts List

The components listed in this parts list are divided into two main types: those with a circuit reference (e.g. C2, D1, R121, etc) and those without (miscellaneous and mechanical). Static sensitive devices are prefixed with (S).

Those with a circuit reference are grouped by component type in numerical order. Each component entry comprises three or four columns: the circuit reference, variant number (if applicable), IPN and description. A number in the variant column indicates that this component is fitted only to that variant.

The miscellaneous and mechanical section lists the parts in IPN order and where possible the legend indicates their position on the exploded view.

### Parts List Amendments

C104	Changed from 011-54100-02 (63V) to 011-04100-02 (50V) (97/04-7072).
*R17 & *R19	Changed from 10E to 22E (030-52100-20) (06/97-720005).
R17 & R19	Two ferrite beads to be placed (065-00010-04) - not previously included (96/10-7175).
R83 & R84	Ferrite beads to be placed (030-52220-20) - not previously included (96/10-7175).
R105	Changed from 1k (030-54100-20) to 1k5 (030-54150-20) to reduce amplitude of noise from noise modulator (710042).

Important mechanical assembly changes to this issue are as follows:

307-02044-00	Add Series II guide rail.
308-01007-01	Add Series II handle.
316-06623-00	Add Series II front panel.
316-21176-02	Rear panel changed from 316-21176-02 to -03 - incorrect IPN in previous issue (96/10-7178).
319-01189-01	Filter shield changed from 319-01189-01 to -02 - new filter shield (750018).
345-00040-08	Add screw M3 x 12 due to thinner fan being fitted (97/10-720025).
345-00040-19	Delete screw M3 x 25mm Pan Pozi ST BZ - not required due to thinner fan being fitted (97/10-720025).
349-00020-07	Delete screw 4-40 x 5/16 Pan Pozi Taptite black - not required in Series II.
353-00010-12	Delete washer M3 Spring BZ or Z/C - not required due to thinner fan being fitted (97/10-720025).



Ref	Var	IPN	Description	Ref	Var	IPN	Description
R24		030-54120-20	RES FILM AI 1K2 5% 0.4W 4X1.6MM	T4		053-00010-63	XFMR T4079 MAINS 5VA 18V
RV25		042-03470-06	RES PRESET 470E CARBON 6MM FLAT	*T5		056-00010-49	CHOKE T4080 T808 DIFFNL MODE ETD39
R26		030-53680-20	RES FILM AI 680E 5% 0.4W 4X1.6MM	T6		056-00010-38	CHOKE T4071 T807-808 DIFFNL MODE
R27		030-54180-20	RES FILM AI 1K8 5% 0.4W 4X1.6MM				
R28		030-53820-20	RES FILM AI 820E 5% 0.4W 4X1.6MM	TC1		239-00010-06	SW THERM PEPI 100C BARE TERML.C/W SLEEVE
R29		030-54270-20	RES FILM AI 2K7 5% 0.4W 4X1.6MM				
R30		030-55100-20	RES FILM AI 10K 5% 0.4W 4X1.6MM				
R32		030-56100-20	RES FILM AI 100K 5% 0.4W 4X1.6MM				
R33		030-54100-20	RES FILM AI 1K 5% 0.4W 4X1.6MM				
R34		030-55100-20	RES FILM AI 10K 5% 0.4W 4X1.6MM				
R35		030-55100-20	RES FILM AI 10K 5% 0.4W 4X1.6MM				
R36		030-55150-20	RES FILM AI 15K 5% 0.4W 4X1.6MM				
R37		030-57100-20	RES FILM AI 1M 5% 0.4W 4X1.6MM				
R38		030-55100-20	RES FILM AI 10K 5% 0.4W 4X1.6MM				
R39		030-54390-20	RES FILM AI 3K9 5% 0.4W 4X1.6MM				
R40		030-54820-20	RES FILM AI 8K2 5% 0.4W 4X1.6MM				
R41		030-54680-20	RES FILM AI 6K8 5% 0.4W 4X1.6MM				
R43		030-55470-20	RES FILM AI 47K 5% 0.4W 4X1.6MM				
R44		030-55100-20	RES FILM AI 10K 5% 0.4W 4X1.6MM				
R45		030-56100-20	RES FILM AI 100K 5% 0.4W 4X1.6MM				
R46		030-55100-20	RES FILM AI 10K 5% 0.4W 4X1.6MM				
R47		030-52220-20	RES FILM AI 22E 5% 0.4W 4X1.6MM				
R48		030-55150-20	RES FILM AI 15K 5% 0.4W 4X1.6MM				
R49		049-00140-10	VARIATOR 140VRMS 180VDC 42 JOULES				
R50		030-54220-20	RES FILM AI 2K2 5% 0.4W 4X1.6MM				
R51		030-55100-20	RES FILM AI 10K 5% 0.4W 4X1.6MM				
R52		030-56180-20	RES FILM AI 180K 5% 0.4W 4X1.6MM				
R53		030-55330-20	RES FILM AI 33K 5% 0.4W 4X1.6MM				
R54B		030-55330-20	RES FILM AI 33K 5% 0.4W 4X1.6MM				
R55		045-05100-01	RES NTC 10K 5% 5MM DISC				
R56		030-55100-20	RES FILM AI 10K 5% 0.4W 4X1.6MM				
R57		030-55270-20	RES FILM AI 27K 5% 0.4W 4X1.6MM				
R58		030-55100-20	RES FILM AI 10K 5% 0.4W 4X1.6MM				
R59		030-57100-20	RES FILM AI 1M 5% 0.4W 4X1.6MM				
R60		030-55100-20	RES FILM AI 10K 5% 0.4W 4X1.6MM				
R61		030-57100-20	RES FILM AI 1M 5% 0.4W 4X1.6MM				
R62		030-54680-20	RES FILM AI 6K8 5% 0.4W 4X1.6MM				
R63		030-52330-20	RES FILM AI 33E 5% 0.4W 4X1.6MM				
R64		030-52220-20	RES FILM AI 22E 5% 0.4W 4X1.6MM				
R65		030-54150-20	RES FILM AI 1K5 5% 0.4W 4X1.6MM				
R66		030-54150-20	RES FILM AI 1K5 5% 0.4W 4X1.6MM				
R67		030-55100-20	RES FILM AI 10K 5% 0.4W 4X1.6MM				
R68		030-56100-20	RES FILM AI 100K 5% 0.4W 4X1.6MM				
R69		030-53680-20	RES FILM AI 680E 5% 0.4W 4X1.6MM				
R70		030-53270-20	RES FILM AI 270E 5% 0.4W 4X1.6MM				
R71		030-54330-20	RES FILM AI 3K3 5% 0.4W 4X1.6MM				
R72		030-52100-20	RES FILM AI 10E 5% 0.4W 4X1.6MM				
R73		030-55100-20	RES FILM AI 10K 5% 0.4W 4X1.6MM				
R74		030-54470-20	RES FILM AI 4K7 5% 0.4W 4X1.6MM				
R75		030-54470-20	RES FILM AI 4K7 5% 0.4W 4X1.6MM				
R76		030-54680-20	RES FILM AI 6K8 5% 0.4W 4X1.6MM				
R79A		032-32100-01	RES M/F PWR 10E 2.5W 17X5MM				
R79B		032-32100-01	RES M/F PWR 10E 2.5W 17X5MM				
R80		030-54100-20	RES FILM AI 1K 5% 0.4W 4X1.6MM				
R80A		030-52100-20	RES FILM AI 10E 5% 0.4W 4X1.6MM				
R80B		030-54180-20	RES FILM AI 1K8 5% 0.4W 4X1.6MM				
*R81		032-33120-01	RES M/F PWR 120E 5% 17*5 2.5 W				
RV81		042-05100-06	RES PRESET 10K CARBON 6MM FLAT				
*R82		032-33120-01	RES M/F PWR 120E 5% 17*5 2.5 W				
R83		030-52220-20	RES FILM AI 22E 5% 0.4W 4X1.6MM				
R84		030-52220-20	RES FILM AI 22E 5% 0.4W 4X1.6MM				
R85		030-08100-31	RES M/F 10M 3.5KV VR37 10*4MM				
R86		030-55470-20	RES FILM AI 47K 5% 0.4W 4X1.6MM				
R87		030-53100-20	RES FILM AI 100E 5% 0.4W 4X1.6MM				
R88		030-54100-20	RES FILM AI 1K 5% 0.4W 4X1.6MM				
R89		030-54470-20	RES FILM AI 4K7 5% 0.4W 4X1.6MM				
R90		030-55470-20	RES FILM AI 47K 5% 0.4W 4X1.6MM				
R91		030-54100-20	RES FILM AI 1K 5% 0.4W 4X1.6MM				
RV92		042-03470-06	RES PRESET 470E CARBON 6MM FLAT				
R93		030-53820-20	RES FILM AI 820E 5% 0.4W 4X1.6MM				
R94		030-54120-20	RES FILM AI 1K2 5% 0.4W 4X1.6MM				
R95		030-55680-20	RES FILM AI 68K 5% 0.4W 4X1.6MM				
R96		030-54680-20	RES FILM AI 6K8 5% 0.4W 4X1.6MM				
R98		030-55100-20	RES FILM AI 10K 5% 0.4W 4X1.6MM				
R99		030-54100-20	RES FILM AI 1K 5% 0.4W 4X1.6MM				
R100		030-55560-20	RES FILM AI 56K 5% 0.4W 4X1.6MM				
R101		030-55560-20	RES FILM AI 56K 5% 0.4W 4X1.6MM				
R102		030-56470-20	RES FILM AI 470K 5% 0.4W 4X1.6MM				
R103		030-55560-20	RES FILM AI 56K 5% 0.4W 4X1.6MM				
R104		030-55100-20	RES FILM AI 10K 5% 0.4W 4X1.6MM				
R105		030-54100-20	RES FILM AI 1K 5% 0.4W 4X1.6MM				
R106		030-53100-20	RES FILM AI 100E 5% 0.4W 4X1.6MM				
R107		030-53100-20	RES FILM AI 100E 5% 0.4W 4X1.6MM				
RLY1		237-00010-30	RELAY 12V COIL 240V 10A SPDT				
SW1		233-00010-07	SWITCH DPDT 115/230V 6PIN				
SW2		232-00020-28	PUSH SWITCH PCB MTG				
SK-3		240-00010-23	PLUG 3 PIN 10AMP 250V PCB MTG				
SK-4		240-04030-06	TRMNL BLOCK 1WAY PC MT PHOENIX				
SK-5		240-04030-06	TRMNL BLOCK 1WAY PC MT PHOENIX				
SK-6		240-04030-07	TERML BLK PCB MTG 1WAY FRT 2.5H/SA10				
SK-7		240-04030-07	TERML BLK PCB MTG 1WAY FRT 2.5H/SA10				
SK-8		240-04030-07	TERML BLK PCB MTG 1WAY FRT 2.5H/SA10				
T1		053-00010-58	XFMR T4073 T807/808 SWITCHING				
T2		053-00010-59	XFMR T4074 T807/808 CURRENT SENSE				
T3		053-01060-02	XFMR T4075 T807/808 MOSFET DRIVE				

## T808 Mechanical &amp; Miscellaneous Parts (220-01183-07)

IPN	Legend	Description	IPN	Legend	Description
200-00010-35		WIRE T/C 1.5MM <sup>2</sup> /1.4MM For L6. 35mm	349-00020-08	13	SCREW TAPTITE 4-40X3/8IN CSK POZI BZ Covers to rails x16
201-00051-15		WIRE APPLC 1MM <sup>2</sup> GREEN HI TEMP PVC85 For Earth Lead	349-00020-34	14	SCREW M3*12 PAN POZI TAPTITE BZ P.C.B. to rails x6
201-00060-09		WIRE REMIT 0.8MM <sup>2</sup> PVC WHITE For Cut Out Switch on T1	352-00010-08	15	NUT M3 COLD FORM HEX ST BZ D43 x1, Mains Socket x2, IC2 x1, Fan x4, Mounting Kit x2 (in bag)
209-00010-26		TAPE COPPER 19MM * 0.08MM SCOTCH 1181 For taping switch to T1	352-00010-29	16	NUT M4 NYLOC HEX Handle x2
220-01183-07	1	PCB T807/T808 SMPS 2 OUNCE COPPER	353-00010-10		WASHER M3 FLAT 7MM*0.6MM ST BZ Mounting Kit x2 (in bag)
240-02010-22		SKT MAINS 3PIN FLEX 2M/10A	353-00010-12	17	WASHER M3 SPRING BZ OR Z/C D43 x1, Mains Socket x2, IC2 x1, Fan x4
*240-04020-72		SOCKET HOUSING 2 WAY MTG ULTREX To connect fan to PL-2	356-00020-06		RECEPTL 6.3MM QUICK CONN FLARED INS For Earth Lead
*240-04020-76		SKT RECEPTACLES WIRE CRIMP ULTREX To connect fan to PL-2	356-00020-07		RECEPTL M3.5QUICK CONN M3.5 OPEN END For Earth Lead
240-06010-27		BLANKING PLATE 2.5MM GREEN Fitted to SK-8	356-00020-21		TAB 6.3MM RT ANGLE SPADE CAR QCK CONN PCB Mounted Earth Connector
*258-00010-04	22	FAN 12V 40 x 40 x 20 TUBE AXIAL Mount to rear panel	362-00010-13	18	BUSH INSULATING 1.1MM TOP HAT D43 Mounting x1
303-23128-02	2	COVR SIDE A2M2403/2 T807/808 COMP SCRNM	362-01024-00	19	INSULATOR 54*30 AS PER DRWG A4M2431 Q1/Q2 x1, D43 x1
306-01010-00	3	FERRULE A4M948 HANDLE FXD EQUIP Place on handle x2	362-01052-00	20	XSTR CLAMPING BRKT T807/808 A4M2407 Bracing bracket for Q1 & Q2 x1
307-02029-00		GUIDE REAR T807/808 A3M2409 Packed in box x2	365-00011-54		LABEL WHITE RW 1556/2 90X24MM SPEC AD For outside of box
308-01007-00	4	HANDLE A4M949 FXD EQUIP Front Panel	365-00013-59		LABEL T807/808 HI VOLT WARNING A4A651
308-13088-00		HSINK CLIP ON 14 OR 16 DIP INT CCTS ICs 4, 5 & 6	365-00100-05		LABEL BLANK 50X9MM S/A METLSD POLYES Mounting Kit x1 (in bag) NB/ Label is to be placed over top of screened version on panel if power supply is to be 115 Volts
308-13091-00		HSINK PCB MTG TO-220 Heatsink for IC2 mounting to PCB	365-01391-01		LABEL BLNK 30X10.8MM TAMPERMARK VOID Ser No x1, Job No x1, Rev No x1 & Elec Insp x1
311-00010-39		KNOB RED PLASTIC ROUND Pushes on to SW2	365-01500-00		LABEL CE CONFORMITY 12*24MM
316-06399-01	5	PNL FRT COMPL T807 A3M2405/2	369-00020-52		TAPE ELECT INSULATION UL APPRVD 130°C For T4
316-21176-02	6	PNL REAR A3M2427/2 T807 COMPL SCRNM	399-00010-10		RUBBER BAND NO 33
318-01018-00	7	RAIL CHASSIS T807/808 A3M2404 Attached to PCB x2	399-00010-51		BAG PLASTIC 75*100MM For Mounting Kit
319-01189-01		SHIELD T807/808 MAINS FILTER Fitted to underside of board across output	400-00020-01		SLEEVING 0.7MM SIL RUBBER For Legs of R13A, R47 & R64
319-30030-01	8	SPACER A4M1115 T807/808 Between P.C.B. & Rails x6	400-00020-03		SLEEVING 1MM SIL RUBBER For Legs of R3, R11, 79A, R79B, R81 & R82
319-40012-00		EARTH STRAP DC T807/808 Fitted to underside of board across input	400-00020-05		SLEEVING 1.5MM SIL RUBBER
345-00040-06	9	SCREW M3*8MM PAN POZI ST BZ SK-3 x2, Mounting Kit x2 (in bag)	400-00020-07		SLEEVING 2MM SIL RUBBER Goes over wire on L6.
345-00040-12		SCREW M3X10MM CSK POZI ST BZ Mounting Kit x6 (in bag)	410-01081-00		CRTN T800 KIWI REF22860 402X192X66MM
345-00040-17	10	SCREW M3*16MM CSK POZI ST BZ D43 x1	410-01082-00		CRTN 10 T800 KIWI REF24417 423X410X360
*345-00040-19	21	SCREW M3*25MM PAN POZI ST BZ Fan x4			
345-00040-24	11	SCREW M3X20MM CSK POZI ST BZ Q1/Q2 Bracing Bracket x1			
349-00020-07	12	SCREW 4-40 X 5/16 PAN POZI TAPTITE BLACK Front x4, Rear x4, Cover x4			

**T808 Mechanical Assembly Exploded View**

***replace A4 pages B8.2.53/B8.2.54 with A3  
pages B8.2.53/B8.2.54, file name 800b84b.100***

T808 Mechanical Assembly Exploded View

***replace A4 pages B8.2.53/B8.2.54 with A3  
pages B8.2.53/B8.2.54, file name 800b84b.100***

## T807/808 Grid Reference Index (IPN 220-01183-07)

### How To Use This Grid Reference Index

The first digit in the PCB layout reference is a "1" or "2", indicating the top or bottom side layout respectively, and the last two characters give the location of the component on that diagram.

The first digit in the circuit diagram reference is the sheet number, and the last two characters give the location of the component on that sheet.

Device	PCB	Circuit	Device	PCB	Circuit	Device	PCB	Circuit	Device	PCB	Circuit
C1	1:U10	1-C6	*C72	1:Q3	1-M8	D38	1:C10	1-J6	R6	1:L10	1-G5
C2	1:U12	1-C5	*C73	1:R3	1-N8	D41	1:G4	1-J8	R7	1:M10	1-G5
C3	1:T11	1-C6	C74	1:M2	1-L9	*D43	1:G2	1-H9	R8	1:L10	1-G5
C4	1:P11	1-D6	C75	1:N2	1-L8			1-H9	R9	1:G10	1-H5
C5	1:Q10	1-D6	C78	1:W3	1-Q9	*FAN	1:Z8	1-J0	R11	1:D2	1-H6
C5A	1:Q10	1-D6	C79	2:Y2	1-R9	*F1	1:V10	1-B6	*R12	1:C7	1-J4
C6	1:Q12	1-D5	C80	1:V2	1-P9	HS	1:P7	2-C0	R13A	1:B10	1-K5
C6A	1:Q12	1-D5	C81	1:V4	1-P8	IC1	1:G8	1-M4	R13B	1:B11	1-K5
*C9	1:K9	1-F6	C82	1:Y4	1-R7			1-Q3	R14	1:C11	1-K5
*C10	1:H11	1-G6	C83	2:W3	1-P8			1-M0	*R17	1:F12	1-M5
*C11	1:H9	1-F5	C84	1:R7	1-N6	IC2	1:P7	1-D3	R18	1:F12	1-L5
*C12	1:K11	1-G5	C85	1:S4	1-P6	IC3	1:U5	1-G2	*R19	1:D12	1-M5
*C13	1:J8	1-H5	C86	1:N4	1-P5			1-G0	R20	1:D12	1-L4
*C14	1:L8	1-H6	C87	1:N5	1-P5			1-D1	R24	1:E8	1-K4
*C15	1:D3	1-H5	C88	1:N5	1-Q5	IC4	1:Q6	1-L0	RV25	1:F8	1-K4
C16	1:B11	1-K5	C89	1:N5	1-R5	IC5	1:R5	1-M1	R26	1:E8	1-K3
C17	1:C8	1-J4	C90	1:X4	1-R6			1-N1	R27	1:G6	1-L4
C18	1:C11	1-K6	C91	1:X4	1-R5			1-L0	R28	1:G6	1-L4
C19	1:G8	1-L6	C92	1:W1	1-R8	IC6	1:R6	1-M1	R29	1:H6	1-L3
C20	1:C12	1-K4	C93	1:W1	1-R8			1-N1	R30	1:G7	1-M4
C21	1:D8	1-J3	C95	1:T5	1-P8			1-L0	R32	1:G6	1-M4
C22	1:G6	1-L4	C96	1:N6	1-J1	IC7	1:S6	1-N6	R33	1:G7	1-M3
C23	1:F6	1-M4	C98	1:N7	1-G1	IC8	1:S4	1-P5	R34	1:G7	1-M3
C24	1:F7	1-M3	C99	1:P7	1-K1	I/OPAD1	1:V5	1-F2	R35	1:G8	1-N3
C25	1:N6	1-M2	C100	1:G7	1-M4	I/OPAD2	1:V5	1-F2	R36	1:M6	1-M3
C26	1:M6	1-M2	C102	1:X11	1-B6	L1	1:X12	1-A5	R37	1:M6	1-N2
C27	1:L6	1-N2	C104	1:H8	1-P1	L1A	1:X10	1-A6	R38	1:M6	1-N2
C31	1:E7	1-Q3	*C112	1:U10	1-C6	L2	1:V11	1-B6	R39	1:C11	1-J6
C32	1:G8	1-Q3	*C113	1:U12	1-C5	L3	1:S11	1-C6	R40	1:C10	1-K6
C33	1:H8	1-M0	*C120	1:X10	1-A6	L4	1:C12	1-K3	R41	1:H7	1-N3
C34	1:H8	1-N0	*C121	1:W12	1-A5	L5	1:C12	1-K4	R43	1:C7	1-K6
C35	1:C12	1-Q1	D1	1:N10	1-F6	L6	1:W3	1-Q9	R44	1:G8	1-Q3
C37	1:P9	1-C2	D2	1:N9	1-F6	L7	1:W5	1-D0	R45	1:C10	1-K6
C38	1:N7	1-D2	D3	1:N8	1-F6	L8	1:W5	1-D0	R46	1:G7	1-K0
C39	1:P7	1-E2	D4	1:M9	1-F6	L9	1:F11	1-M5	R47	1:G6	1-N0
C42	1:W7	1-E2	D5	1:D7	1-J4	L10	1:D11	1-M5	R48	1:F7	1-P3
C43	1:V5	1-F2	D6	1:D8	1-J4	L12	1:T4	1-Q8	R49	1:N10	1-B2
C44	1:U5	1-F2	D7	1:C8	1-J3	L13	1:T4	1-Q7	R50	1:V6	1-E2
C45	1:W6	1-F1	D8	1:C7	1-J3	L14	1:T4	1-Q7	R51	1:W7	1-F2
C46	1:W6	1-F0	D11	1:C12	1-H2	L15	1:T4	1-Q7	R52	1:V5	1-G3
C49	1:U6	1-D1	D12	1:B11	1-K5	PL-1	1:D9	1-E0	R53	1:U7	1-F2
C50	1:V6	1-E1	D13	1:A11	1-K5	*PL-2	1:T6	1-H0	R54B	1:U5	1-F2
C51	1:W5	1-D0	D14	1:G11	1-L6	*Q1	1:G12	1-L5	R55	1:W6	1-E1
C54	1:P5	1-K0	*D15	1:G12	1-L6	*Q2	1:E12	1-L4	R56	1:W6	1-F0
C55	1:Q5	1-K2	*D18	1:E12	1-L5	Q3	1:H6	1-L3	R57	1:W6	1-F1
C56	1:P4	1-K2	D19	1:E11	1-L4	Q4	1:M6	1-N2	R58	1:W6	1-F0
C57	1:Q5	1-K2	D20	1:H7	1-N4	Q6	1:U6	1-H0	R59	1:V5	1-G1
C59	1:P6	1-K1	D21	1:H7	1-P4	Q7	1:B11	1-J2	R60	1:F7	1-P3
C60	1:Q5	1-M2	D22	1:N6	1-M3	Q8	1:T5	1-N7	R61	1:G8	1-Q3
C61	1:Q7	1-K0	D23	1:A12	1-R2	Q9	1:H5	1-K8	R62	1:U6	1-G0
C62	1:Q6	1-K0	D24	1:Q8	1-C2	Q10	1:B12	1-R2	R63	1:U6	1-H0
C63	1:H7	1-N1	D25	1:P8	1-C2	Q11	1:P6	1-H1	R64	1:V6	1-D1
C65	1:G5	1-K8	D26	1:N8	1-C2	Q12	1:P6	1-H1	R65	1:B11	1-J3
C66	1:G3	1-H8	D27	1:P8	1-C2	Q13	1:M7	1-J1	R66	1:B11	1-J3
C67	1:F3	1-J8	D30	1:U7	1-F3	R1	1:X9	1-A6	R67	1:C11	1-J2
*C68	1:P2	1-L8	D31	1:V6	1-F2	R2	1:N11	1-E6	R68	1:C12	1-Q1
*C69	1:Q2	1-L8	D32	1:A11	1-J2	R3	1:U8	1-E6	R69	1:B12	1-R2
*C70	1:R2	1-M8	D36	1:Q6	1-L1	R4	1:M8	1-G6	R70	1:P5	1-L2
*C71	1:P3	1-M8	D37	1:Q6	1-M1	R5	1:L10	1-G6	R71	1:P6	1-K1

<u>Device</u>	<u>PCB</u>	<u>Circuit</u>	<u>Device</u>	<u>PCB</u>	<u>Circuit</u>	<u>Device</u>	<u>PCB</u>	<u>Circuit</u>	<u>Device</u>	<u>PCB</u>	<u>Circuit</u>
R72	1:P6	1-K1									
R73	1:P4	1-K0									
R74	1:Q6	1-M2									
R75	1:Q6	1-M2									
R76	1:H8	1-Q2									
R79A	1:G2	1-H9									
R79B	1:G2	1-J9									
R80	1:T4	1-J9									
R80A	1:F4	1-J8									
R80B	1:G5	1-K8									
*R81	1:J5	1-K9									
RV81	1:F7	1-P3									
*R82	1:J5	1-K9									
R83	1:T5	1-Q7									
R84	1:T5	1-Q7									
R85	1:T2	1-P9									
R86	1:T4	1-N7									
R87	1:T4	1-P6									
R88	1:S5	1-P6									
R89	1:T4	1-Q6									
R90	1:S4	1-P6									
R91	1:N4	1-N5									
RV92	1:S5	1-Q5									
R93	1:T5	1-Q5									
R94	1:P5	1-Q5									
R95	1:N5	1-Q4									
R96	1:N5	1-R5									
R98	1:U4	1-P7									
R99	1:W4	1-P7									
R100	1:N6	1-H1									
R101	1:Q6	1-H1									
R102	1:N6	1-J1									
R103	1:N5	1-J1									
R104	1:N5	1-J1									
R105	1:M7	1-J1									
R106	1:H7	1-N4									
R107	1:H7	1-P4									
RLY1	1:V8	1-J9									
		1-F6									
SW1	1:N12	1-E5									
		1-A3									
SW2	1:C9	1-J3									
SK-1		1-E0									
SK-2	1:X7	1-H0									
SK-3	1:X10	1-A4									
SK-4	1:X2	1-R9									
SK-5	1:X3	1-R8									
SK-6	1:Y3	1-R6									
SK-7	1:Y3	1-R6									
SK-8	1:Y4	1-R7									
T1	1:C5	1-J5									
T2	1:B8	1-J5									
T3	1:F10	1-M4									
T4	1:S8	1-B2									
*T5	1:K3	1-K8									
T6	1:T3	1-P8									
TAB-1	1:Y8	1-A7									
TC1		1-E3									
TP1	1:N7	1-G6									
TP2	1:G10	1-G5									
TP3	1:D8	1-J4									
TP4	1:L7	1-B0									
TP5	1:C9	1-E3									
TP6	1:K7	1-P1									
TP7	1:J7	1-P1									



# Part C T800-22-0000

## Base Station/Repeater Rack Frame

This part of the manual is divided into three sections, as listed below. There is a detailed table of contents at the start of each section.

<b>Section</b>	<b>Title</b>
<b>1</b>	<b>General Information</b>
<b>2</b>	<b>Circuit Operation</b>
<b>3</b>	<b>T800-22-0000 PCB Information</b>



# 1 T800-22-0000 General Information

This section provides a description and specification of the T800-22-0000 base station/repeater rack frame.

The following topics are covered in this section.

<b>Section</b>	<b>Title</b>	<b>Page</b>
<b>1.1</b>	<b>The T800-22-0000 Rack Frame</b>	<b>1.3</b>
1.1.1	Panels	1.3
1.1.2	Guides	1.4
1.1.3	Backplane PCB	1.5
1.1.4	Series II Optional Kits	1.6
<b>1.2</b>	<b>Specifications</b>	<b>1.8</b>



## 1.1 The T800-22-0000 Rack Frame

The T800-22-0000 is a standard 5U high, 19" wide base station/repeater rack frame. The rack frame houses the range of T800 Series II modules within the frequency range 66-960MHz, with power outputs ranging from 1-100W. It can be configured as a base station or repeater by changing links on the backplane PCB.

Figure 1.1 shows the mechanical layout of the T800-22-0000 rack frame. This is shown in more detail, along with specific components and parts lists, in Section 3.3.

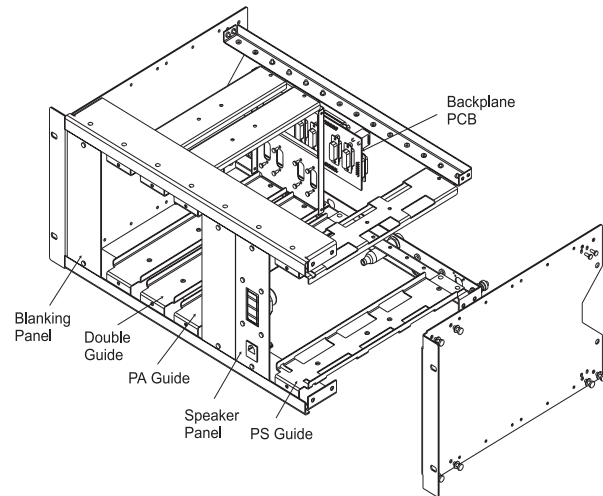

Figure 1.1

A brief description of each component is given below.

### 1.1.1 Panels

The T800-22-0000 rack frame comes complete with two blank panels and a speaker panel. The placement of these panels is shown above in Figure 1.1, with a front view shown in Figure 1.2.

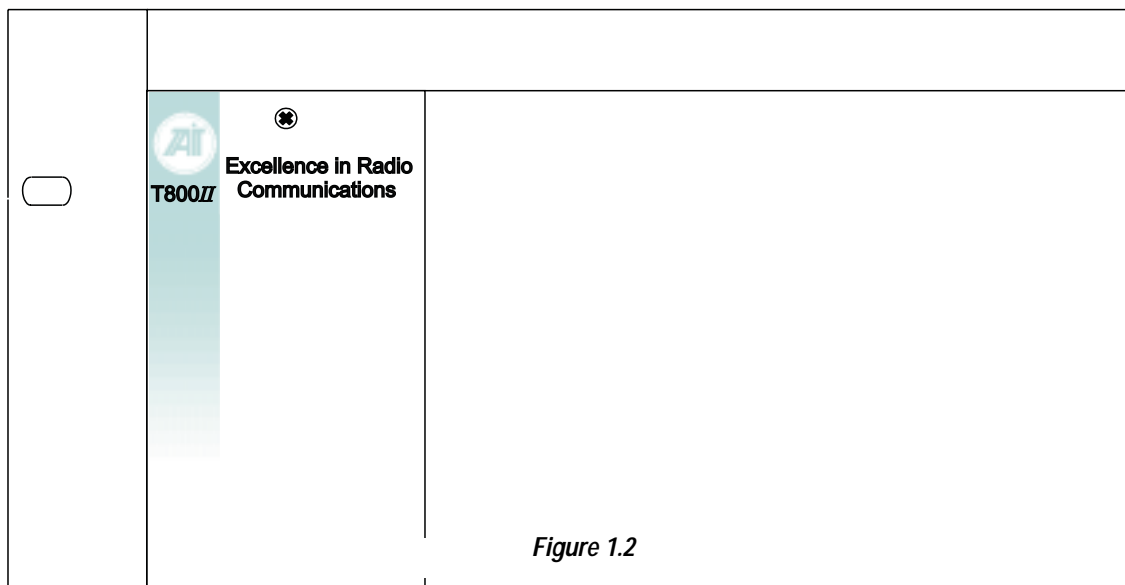

Figure 1.2

### Blank Panels

Blank panels are optional, and are used to cover up empty spaces in a rack frame.

## Speaker Panel

The speaker panel, shown right, is fitted with an RJ11 connector for programming T800 Series II modules via a programming lead. If the speaker panel needs to be removed, a mirror RJ11 programming port connector is provided on the backplane PCB.

The speaker panel is described further in Section 2.4.

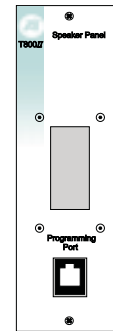

Figure 1.3

### 1.1.2 Guides

The guide kits listed below are available for the T800-22-0000 rack frame. They are illustrated in Figure 1.1 in this section, and more information can be found in Section 1.1.4 and in Section 3.3.

- **Double guide kit**  
This kit fits into a T800 Series II rack frame and accepts two T800 Series II modules (except for power supplies and power amplifiers which must use their own guides). Refer to Sections 1.1.4 & 3.3 for more information and illustrations.
- **Power Supply (T807/8) guide kit**  
This kit fits into a T800 Series II rack frame and accepts one T800 Series II power supply (refer to Sections 1.1.4 & 3.3 for more information and illustrations).
- **PA (50W) guide kit**  
This kit fits into a T800 Series II rack frame and accepts one T800 Series II 50W power amplifier (refer to Sections 1.1.4 & 3.3 for more information and illustrations).
- **PA (100W) guide kit**  
This kit fits into a T800 Series II rack frame and accepts one T800 Series II 100W power amplifier (refer to Sections 1.1.4 & 3.3 for more information and illustrations).

### 1.1.3 Backplane PCB

The backplane PCB has been laid out with OEM (Original Equipment Manufacturer) products in mind. The T800-22-0000 rack frame can be configured as either a base station or repeater by means of five link jumpers.

The main components of the backplane PCB are listed below.

- RJ11 connector - used for module programming whenever the speaker panel has been removed
- Two 25-way D-ranges - supplying all Rx and Tx/Ex/PA module pinouts.
- Two channel select DIP switches (SW1 and SW2) - can be operated separately for Rx or Tx/Ex, or combined for a single channel selection across both Rx and Tx/Ex modules. The DIP switches will only work when DR2 is connected to the module.
- A coaxial relay driver (CN1) - used in base station mode.
- A cooling fan driver (CN2) - activated off the Tx key line.

These components are all described further in Section 2.

- A programming connector (CN3) - used for looping the serial programming port from backplane to backplane.

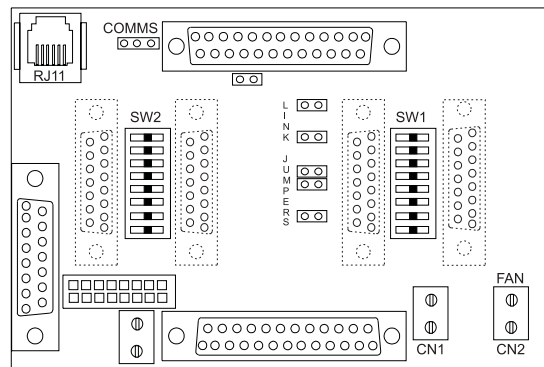

Figure 1.4 Layout Of Backplane PCB 220-01409-01

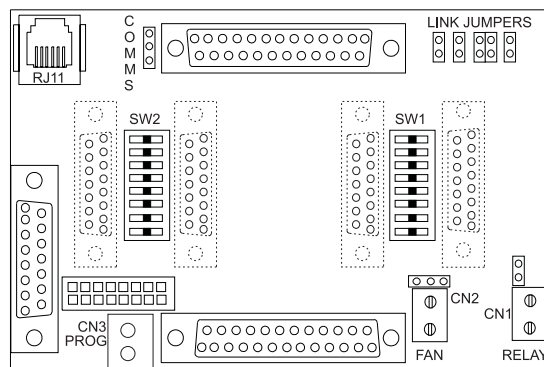

Figure 1.5 Layout Of Backplane PCB 220-01409-03

## 1.1.4 Series II Optional Kits

There are several Series II optional kits available for the T800-22-0000 rack frame. These are listed below with their appropriate Product Codes which should be used for ordering purposes from your nearest Tait Dealer or Subsidiary.

### General Ancillary Kits

- **T004-72**      **RF Coaxial relay kit**  
An assembly fitted with three female N-type connectors, complete with a mounting bracket and two coaxial cables terminated in male N-type connectors (refer to Section 2 for more information).
- **T800-03-0000**      **Auxiliary D-range kit**  
An additional D-range kit, normally fitted as D-range 2, comprising one D-range plug assembly complete with connecting loom and mounting screws. The ribbon cable loom connects the D-range PCB to the Micromatch socket (SK805) in the microcontroller compartment. This kit is typically used in paging applications and where external channel control is needed.

### Front Panel Kits

- **T800-15-0000**      **Speaker/Programming port kit**  
A 60mm speaker panel fitted with a 4Ω speaker and complete with mounting hardware (refer to page 1.4 in this section, and Sections 2 & 3 for illustrations and more information).
- **T800-40-0001**      **Blank panel with fitting kit**  
The blank panel is used to cover up empty spaces in a rack frame. The kit comprises the blanking guide, blank panel and mounting screws (refer to Section 3 for illustration).

### Rack Ancillaries

- **T800-19-0000**      **Rack fan kit - rail mounted**  
This kit features a rack mounting fan which is designed to fit into the base of any standard 483mm rack frame without affecting its ability to house seven modules. The kit contains all mounting hardware.
- **T800-19-0010**      **Rack fan kit - Series II guide mounted**  
This kit features a guide mounting fan, and includes all mounting hardware.



## Guide Kits

- **T800-41-0002 Double guide kit**  
This kit fits into a T800 Series II rack frame and accepts two T800 Series II modules (except for power supplies and power amplifiers which must use their own guides). It is supplied disassembled and comprises a top and bottom rail, a double width rear panel, four D-range sockets and mounting screws (refer to Section 3.3 for an illustration and more information).
- **T800-44-0000 Power Supply (T807/8) guide kit**  
This kit fits into a T800 Series II rack frame and accepts one T800 Series II power supply. It comprises a top and bottom rail and mounting screws (refer to Section 3.3 for an illustration and more information).
- **T800-45-0000 PA (50W) guide kit**  
This kit fits into a T800 Series II rack frame and accepts one T800 Series II 50W power amplifier. It comprises a top guide stop, a bottom guide rail and mounting screws (refer to Section 3.3 for an illustration and more information).
- **T800-45-0001 PA (100W) guide kit**  
This kit fits into a T800 Series II rack frame and accepts one T800 Series II 100W power amplifier. It comprises a top guide stop, a bottom guide rail, extra mounting brackets for the double width front panel and mounting screws (refer to Section 3.3 for an illustration and more information).

## Rack PCBs

- **T800-50-0000 Standard rack backplane PCB**  
This PCB is described in detail in Section 1.1.3. Refer to Section 3.2 for illustrations and more information.
- **T800-60-0000 Personality PCB for monitor and channel select**

## 1.2 Specifications

The performance figures given are minimum figures, unless otherwise indicated.

Details of test methods and the conditions that apply for safety and EMC testing can be obtained from Tait Electronics Ltd.

### General:

Frequency Range	.. base station .. repeater
Coaxial Relay Driver	.. negative volts switched
Cooling Fan Driver	.. negative volts switched
Channel Selection	.. single DIP switches for both Rx and Tx/Ex modules plus paralleled external select line via SK6
Speaker Output	.. 4 Ohm nominal 2W
Programming Port	.. 5V logic levels
Fuse:	
T8x6/T8x8 or 25/50W	.. 15A slow blow
T8x9 100W	.. 30A slow blow
OEM Output Connectors	.. via two 25-way D-range sockets

### Wire:

Power supply wire consists of red and black 154 auto cable (41/0.3 PVC). All other wire consists of tinned Copper 7/0.2 PVC coated wire.

Tri-rated cable	.. 56/0.3mm (4.0mm) - 12 AWG
Max. operating temperature	.. 105°C
Voltage rating	.. 600V
Nominal outside dia	.. 4.3mm
Current rating at 30°C	.. 41 amps

**Note:** Optional Tri-rated cable for power supply feeds is available on request.

**Dimensions:**

Height	.. 222mm (5U high)
Width	.. 482mm (19" rack mount)
Length	.. 322mm plus clearance space of 50mm

**Weight:**

.. 4.5kg



## 2 T800-22-0000 Circuit Operation

This section provides a basic description of the circuit operation of the T800-22-0000 base station/repeater rack frame.

The following topics are covered in this section.

<b>Section</b>	<b>Title</b>	<b>Page</b>
<b>2.1</b>	<b>Channel Select Lines And DIP Switch Operation</b>	<b>2.3</b>
<b>2.2</b>	<b>PGM800Win DIP Switch Assignment</b>	<b>2.4</b>
<b>2.3</b>	<b>Link Configuration</b>	<b>2.5</b>
<b>2.4</b>	<b>Speaker And Programming Port</b>	<b>2.6</b>
<b>2.5</b>	<b>Cooling Fan Driver</b>	<b>2.7</b>
<b>2.6</b>	<b>Coaxial Relay Driver</b>	<b>2.8</b>
<b>2.7</b>	<b>Power Supply Configuration For Backplane PCB</b>	<b>2.9</b>



## 2.1 Channel Select Lines And DIP Switch Operation

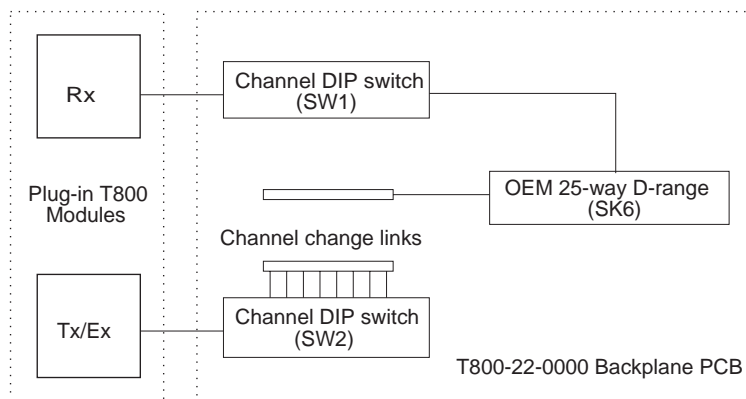

Figure 2.1 Channel Select Lines And DIP Switch Operation

Refer to the above Figure.

External channel selection is only available if an optional D-range (T800-03-0000) has been fitted to one or both T800 Series II modules.

The channel selection lines need to be set to ground to change their states, as they pull up to 5V normally.

Both Rx and Tx/Ex T800 Series II modules have a separate 8-way DIP switch available on the backplane PCB. You can use this switch to select one channel from any of the channels already programmed into the module by PGM800Win.

**Note:** Channels 1-128 must be programmed using PGM800Win.

PGM800Win can provide the user with a DIP switch code for each channel address, for example channel 125 will be assigned a switch code of 10000010 (1-128 numbering). In this case the DIP switches should be set as shown at right. (See Section 2.2 for switch assignment).

**Note:** The DIP switch settings override the default channel programmed by PGM800Win. To set a default channel via the software, all DIP switches must be set to “off” (i.e. 00000000).

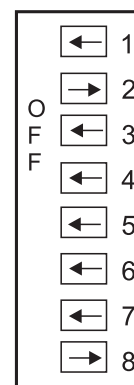

The channel select DIP switches may also be paralleled for single channel operation across both Rx and Tx/Ex modules. To do this, solder bridge the channel change links, shorting them out. Then set all 8 switches on SW2 to off, and use SW1 for the master channel selection across both modules.

When the two modules have been linked via the channel change links, the channel select lines may also be accessed via the OEM 25-way D-range (SK6 - refer to Figure 2.6).

## 2.2 PGM800Win DIP Switch Assignment

The DIP switches are a form of binary counting to select channel numbers. The binary value of each DIP switch is shown below.

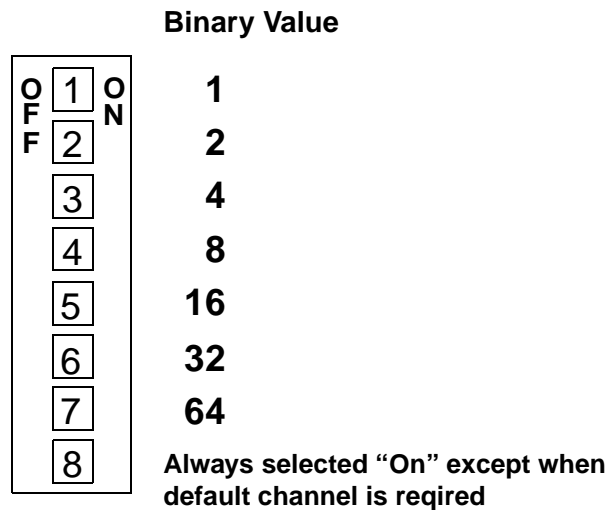

When a switch is "Off" its binary count is active, when a switch is "On" its binary count is inactive.

The various combinations of switching a DIP switch on or off provide a total, which is then the channel number.

To select a channel, set the appropriate DIP switch or switches to "Off" to make the binary count total the channel number you want. Set all other switches to "On".

**Example:** To select channel 125, the DIP switch settings are as shown below.

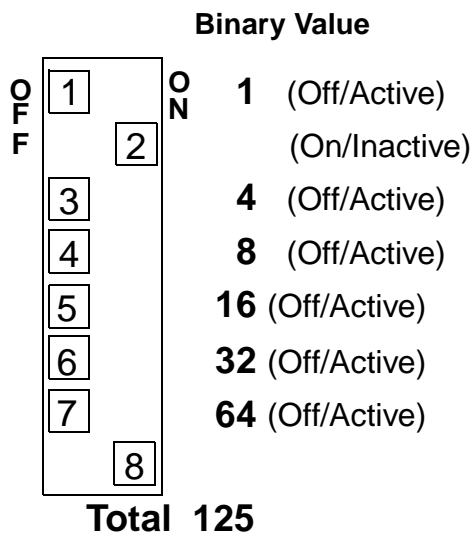



## 2.3 Link Configuration

The backplane PCB has link jumpers which are used for configuring rack frame functions as described in the table below.

Link	Description	Function
1	Audio 1	Fitted for repeater function.
2	Audio 2	Normally fitted LN2-1 to LN3-1 LN2-2 to LN3-2 (centre taps). Only changes for special applications. Contact your nearest Tait Dealer or Subsidiary for more information.
3	Audio 3	
4	Audio 4	Fitted for repeater function.
5	Rx Gate/Tx Key	Fitted for repeater function.
6	Serial Comms	Fitted 1-2 - program through D-range 2. Fitted 2-3 - program through D-range 1.
7	Optional	Link normally fitted.
8 (Backplane PCB 220-01409-03 Only)	Fan Drive	If the link is not fitted there is no fan operation. Fitted 1-2 - fan runs when Tx is keyed. Fitted 2-3 - fan runs continuously.

**Note 1:** Link LN2-1 to LN3-1  
LN2-2 to LN3-2 to set the configuration for a base station.

**Note 2:** Link LN1 to LN5 to set the configuration for a repeater.

## 2.4 Speaker and Programming Port

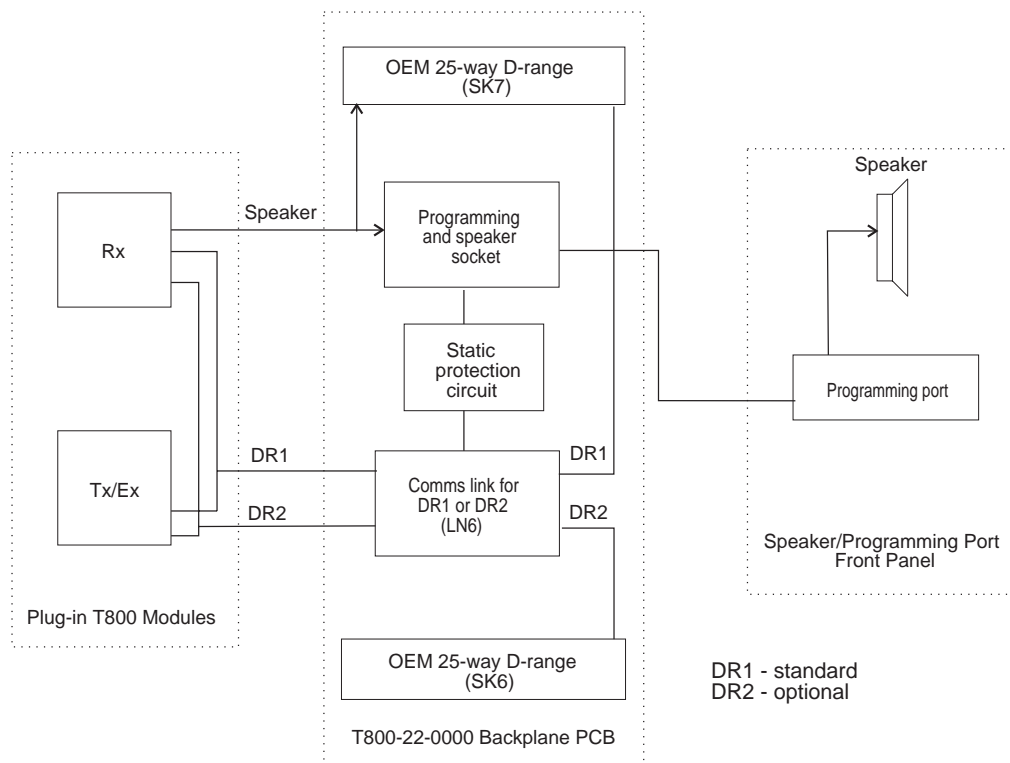

Figure 2.2 Speaker and Programming Port Configuration

The T800-22-0000 has a standard Series II speaker/programming port front panel fitted (T800-15-0000). This panel has an RJ11 connector for programming via the programming lead (T800-01-0002). If the speaker/programming port front panel needs to be removed, a mirror RJ11 programming port connector is provided on the backplane PCB.

There is a static protection circuit for EMC requirements which will dissipate spikes of greater than  $\pm 5.6V$  to ground via both the speaker/programming port front panel socket and the backplane PCB programming socket.

LN6 is used to select the communications link to the module via either DR1 or DR2.

SK/Pin Connections	LN6 Link	Programming Via	D-range Fitted
SK7, Pin 7	Rx1/Tx1, Pins 7/7	DR1, Pin 7	DR1
SK6, Pin 24	Rx2/Tx2, Pins 12/24	DR2 Pin 12 or DR1 Pin 7	DR1 & DR2

## 2.5 Cooling Fan Driver

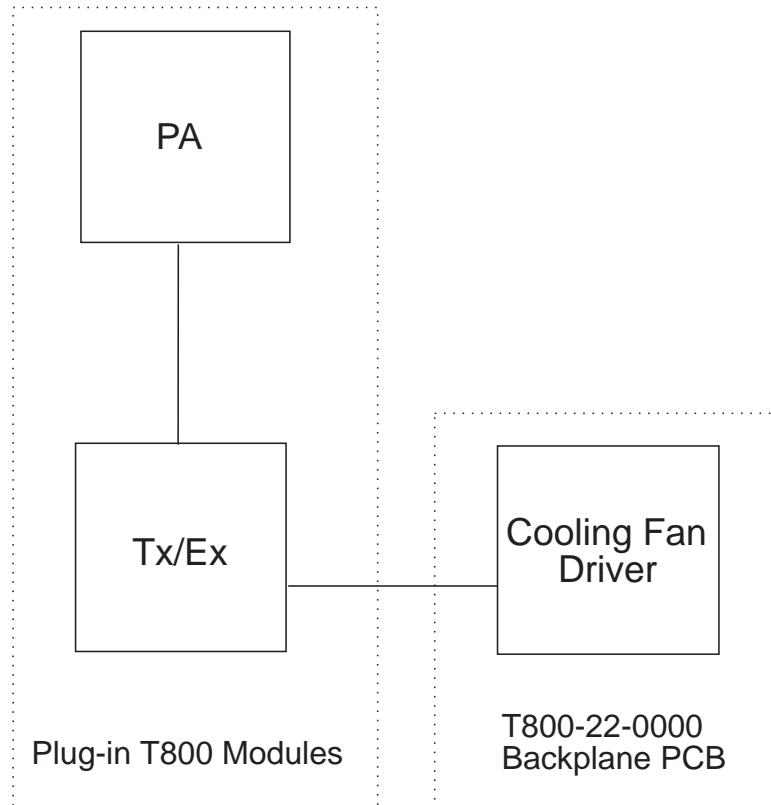
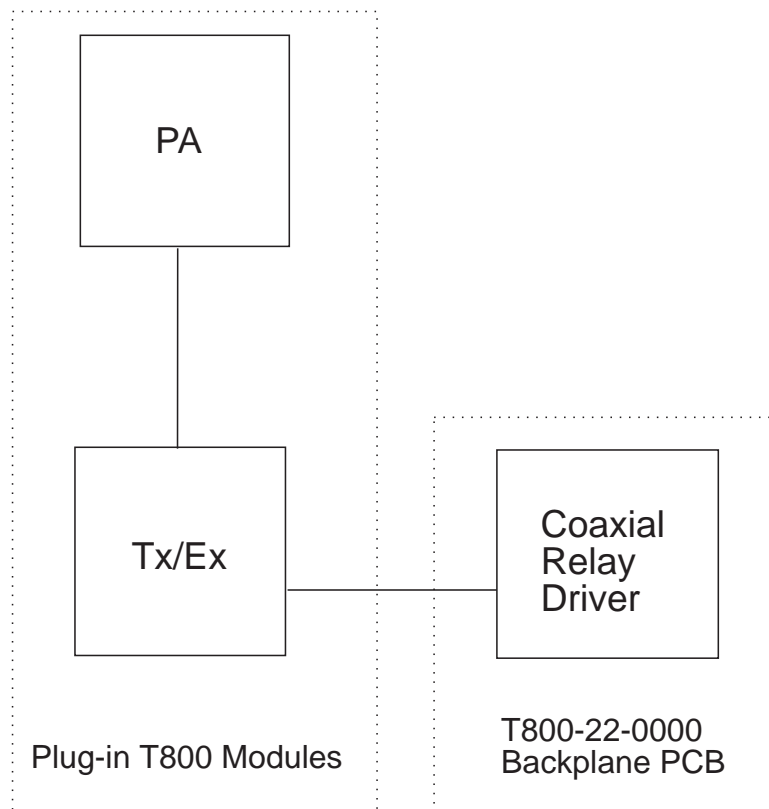

*Figure 2.3 Cooling Fan Driver*

The fan driver is supplied via a BC327 PNP transistor (Q1), which is switched by the Tx key line (DR1 pin 5 of Tx/Ex) to supply negative volts on CN2 pin 2. (Refer to Section 3.2 for the backplane PCB layout and the location of CN2.) CN2 pin 1 is supplied continuously by +13.8V. The fan and mounting hardware is supplied as optional kits (T800-19-0000 Series II fan mounted underneath the rack frame, T800-19-0010 Series II guide mounted fan.).

The side panels of the rack also provide mounting holes for the old Series I fan assembly. The fan may be fitted in a front, middle or rear mounted position on the guide rails. This hardware is supplied as an optional kit (T800-19).

## 2.6 Coaxial Relay Driver

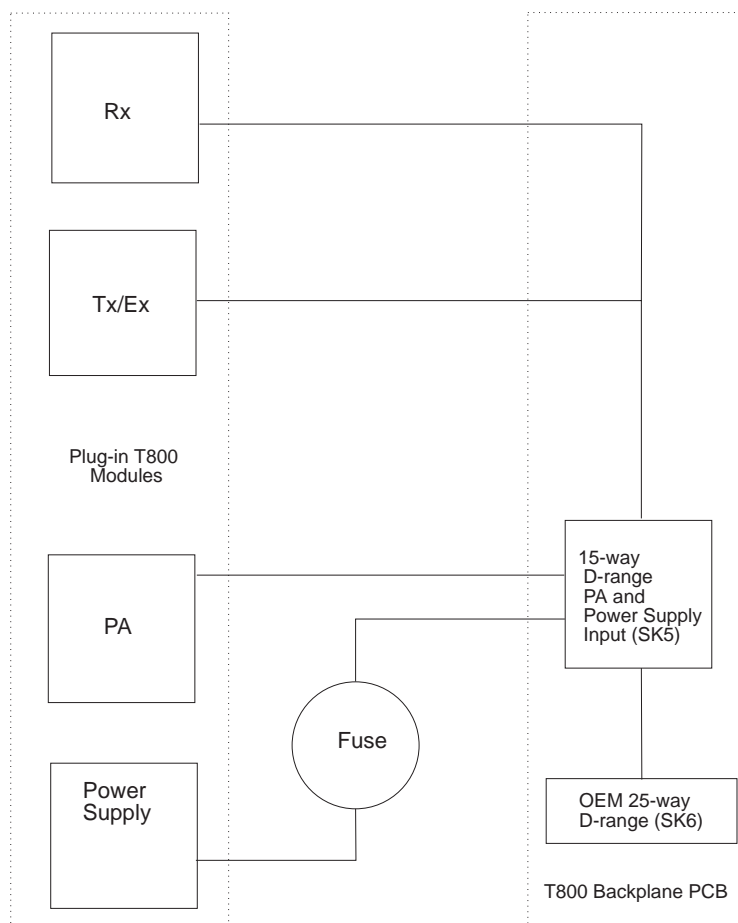

*Figure 2.4 Coaxial Relay Driver*

The coaxial relay driver connector (CN1) has +13.8V continuously supplied on pin 1. (Refer to Section 3.2 for the backplane PCB layout and the location of CN1.) Negative volts are supplied via CN1 pin 2 from DR2 pin 9 when the optional D-Range (T800-03-0000) is fitted. Modifications to Rx disable should be carried out on the Rx module. The module is linked in via LN7 on the backplane PCB.

The coaxial relay kit (T004-72) is available from your nearest Tait Dealer or Subsidiary.

## 2.7 Power Supply Configuration For Backplane PCB



*Figure 2.5 Power supply configuration for backplane PCB*

The power supply feed is arranged so that maximum voltage and current is supplied to 50/100W PAs (when fitted) and 25W PAs (when higher power modules are not fitted).

The supply is fused between the power supply and high powered PA modules by a Bussmann fuse holder on the rear bottom rail. The following fuses should be used:

- 15A slow blow for T8X6, T8X8
- 30A slow blow for T8X9.

Supply to the backplane PCB is via a 15-way D-range (SK5) which supplies both Rx and Tx/Ex modules. It also provides an OEM power supply on SK6 of +13.8V, 6A.



## 3 T800-22-0000 PCB Information

This section provides parts lists, mechanical assembly drawings, PCB layouts and circuit diagrams for the base station/repeater rack frame, backplane PCB and personality PCB.

**Note:** The backplane PCB is available separately under the product code T800-50-0000.

This section contains the following information.

Section	Title	Page
3.1	Introduction	3.1.3
3.2	T800-22-0000 PCB Information	3.2.1
3.3	T800-22-0000 Rack Frame Parts Lists	3.3.1





## 3.1 Introduction

### PCB Identification

All PCBs are identified by a unique 10 digit “internal part number” (IPN), e.g. 220-12345-00, which is screen printed onto the PCB (usually on the top side), as shown in the example below:



The last 2 digits of this number define the issue status, which starts at 00 and increments through 01, 02, 03, etc. as the PCB is updated. Some issue PCBs never reach full production status and are therefore not included in this manual. A letter following the 10 digit IPN has no relevance in identifying the PCB for service purposes.

**Note:** It is important that you identify which issue PCB you are working on so that you can refer to the appropriate set of PCB information.

### Parts Lists

The 10 digit numbers (000-00000-00) in this Parts List are “internal part numbers” (IPNs). Your spare parts orders can be handled more efficiently if you quote the IPN and provide a brief description of the part.

The components listed in this parts list are divided into two main types: those with a circuit reference (e.g. C2, D1, R121, etc.) and those without (miscellaneous and mechanical).

Those with a circuit reference are grouped in alphabetical order and then in numerical order within each group. Each component entry comprises three or four columns, as shown below:

Ref	Var	IPN	Description
C126		015-06100-08	CAP CER 1206 CHIP 100N 10% X7R 50V
C127		020-09220-01	CAP ELECT RADL 220M 16V 10X12.5MM
C128		015-06100-08	CAP CER 1206 CHIP 100N 10% X7R 50V
C129		015-06100-08	CAP CER 1206 CHIP 100N 10% X7R 50V
&C130	10	015-25100-08	CAP CER 0805 CHIP 10N 10% X7R 50V
&C130	15	015-24470-08	CAP CER 0805 CHIP 4N7 10% X7R 50V
&C130	20	015-25100-08	CAP CER 0805 CHIP 10N 10% X7R 50V
&C130	25	015-24470-08	CAP CER 0805 CHIP 4N7 10% X7R 50V
C131		015-24100-08	CAP CER 0805 CHIP 1N 10% X7R 50V
C132		015-24470-08	CAP CER 0805 CHIP 4N7 10% X7R 50V
C133		015-05470-08	CAP CER 1206 CHIP 47N 10% X7R 50V

circuit reference - lists components in alphanumeric order  
 variant column - indicates that this is a variant component which is fitted only to the product type listed  
 description - gives a brief description of the component  
 Internal Part Number - order the component by this number

The miscellaneous and mechanical section lists the variant and common parts in IPN order.



## 3.2 T800-22-0000 PCB Information

This section contains the following information on the T800-22-0000 backplane PCB.

**Note:** The backplane PCB is available separately under the product code T800-50-0000.

IPN	Section	Page
220-01409-00	Parts List For 220-01409-01 And 220-01409-03	3.2.3
	PCB Layout - Bottom Side	3.2.4
	PCB Layout - Top Side	3.2.5
	T800 Receiver Standard Inputs And Outputs	3.2.6
	Receiver Additional Inputs And Outputs	3.2.7
	Transmitter/Exciter Standard Inputs And Outputs	3.2.8
	Transmitter/Exciter Additional Inputs And Outputs	3.2.9
	Power Amplifier Standard Inputs and Outputs	3.2.10
	Circuit Diagram	3.2.11
	Input/Output Pins	3.2.12
	PCB Mechanical Layout	3.2.13
	Personality PCB Mechanical Layout	3.2.14



## T800-22-0000 Parts List (IPN 220-01409-01 And IPN 220-01409-03)

### How To Use This Parts List

The components listed in this parts list are divided into two main types: those with a circuit reference (e.g. C2, D1, R121, etc.) and those without (miscellaneous and mechanical).

Those with a circuit reference are grouped in alphabetical order and then in numerical order within each group. Each component entry comprises three or four columns: the circuit reference, variant (if applicable), IPN and description. A number in the variant column indicates that this is a variant component which is fitted only to the product type listed.

The miscellaneous and mechanical section lists the variant and common parts in IPN order.

### Parts List Amendments

Ref	Var	IPN	Description	IPN	Legend	Description
CN1		240-04030-09	TERMINAL BLK PCB MTG 2W 5MM LS	220-01409-01		PCB BACKPLANE T800-22-000
CN2		240-04030-09	TERMINAL BLK PCB MTG 2W 5MM LS			
CN3		240-04030-09	TERMINAL BLK PCB MTG 2W 5MM LS	220-01409-03		PCB BACKPLANE T800-22-0000
D1		001-00011-70	S) DIODE 1N4001 1A/50V			
D2		001-50012-00	S) DIODE AI 1N4148 SI			
D3		001-50012-05	S) DIODE AI 1N4531 SI S-SIG	240-02020-15		SKT 15 DRANGE PCB PLUS PCB HW SK5
D4		001-00015-19	S) DIODE ZEN 5V6 0.4W 2% BZX79			
LN1		240-00020-68	HEADER 2W PCB MTG STD			
LN2		240-00020-68	HEADER 2W PCB MTG STD	240-02020-20		SKT 25 DRANGE PCB PLUS FULL HW SK6/7
LN3		240-00020-68	HEADER 2W PCB MTG STD			
LN4		240-00020-68	HEADER 2W PCB MTG STD			
LN5		240-00020-68	HEADER 2W PCB MTG STD			
LN6		240-00020-59	HEADER 3W 1R PCB MTG STD	240-04020-62		SKT 2 W RECEP SHORTING LINK Links LN1-8
LN7		240-00020-68	HEADER 2W PCB MTG STD			
LN8		240-00020-59	HEADER 3W 1R PCB MTG STD			
Q1		000-00010-60	S) XSTR BC327 PNP AF PWR TO92			
R1		030-56120-20	RES FILM AI 120K 5% 0.4W 4X1.6			
R2		030-02100-00	RES FILM 10E 5% 0.25W 7X2.5			
RJ1		240-04021-60	SKT P/JACK 6-WAY VER 69254-001			
SW1		230-00010-19	SWITCH*8 SPST DIP PKG			
SW2		230-00010-19	SWITCH*8 SPST DIP PKG			

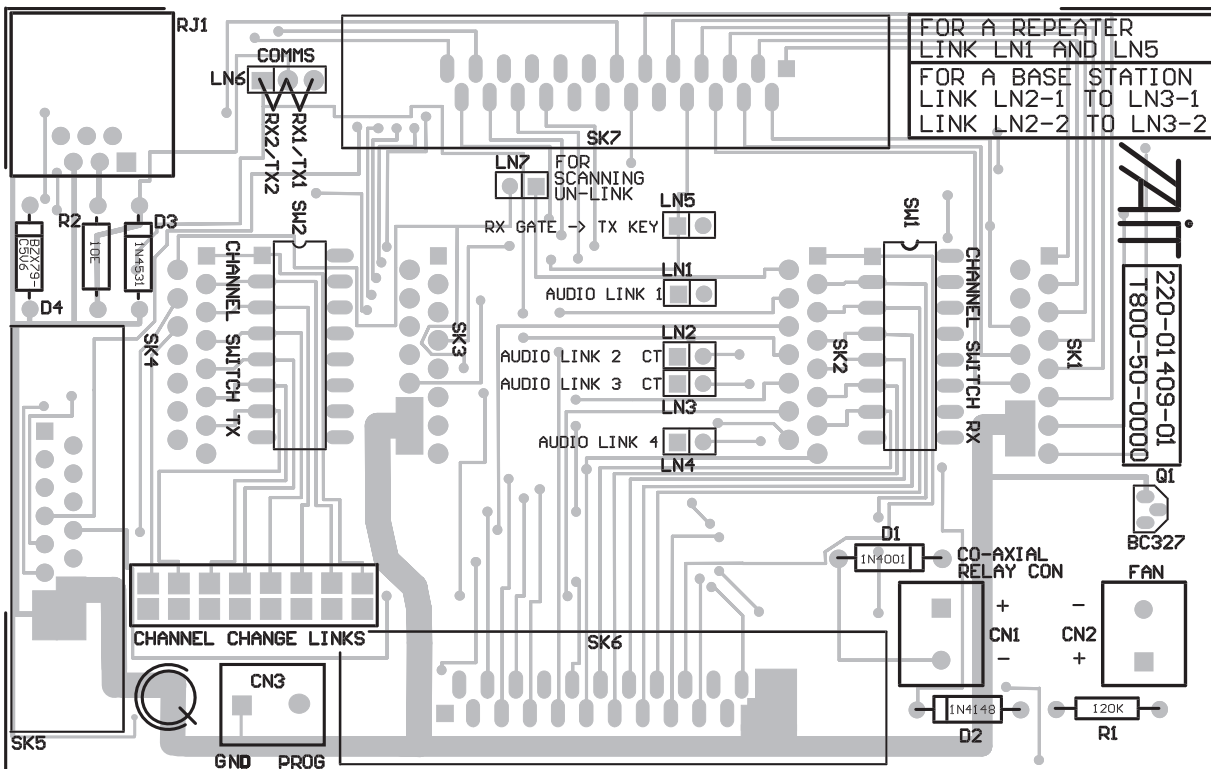
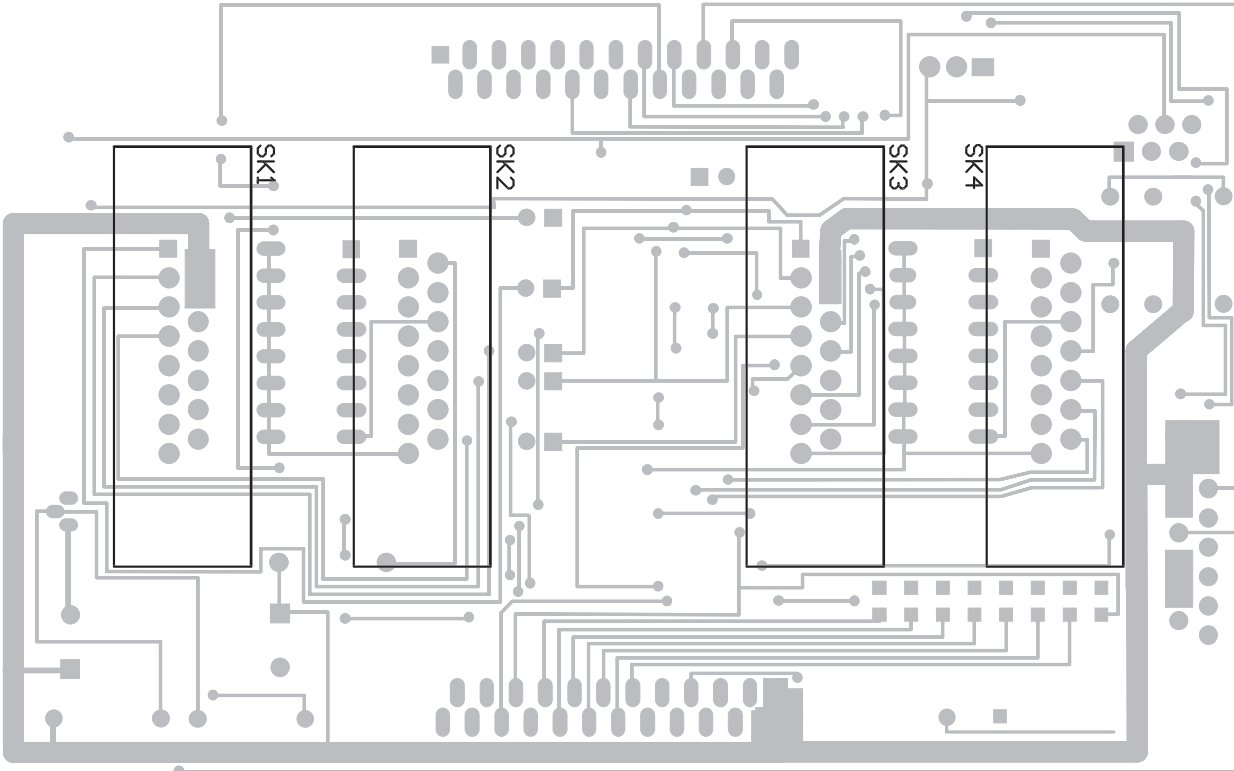

T800-22-0000 PCB (IPN 220-01409-01) - Bottom And Top Sides

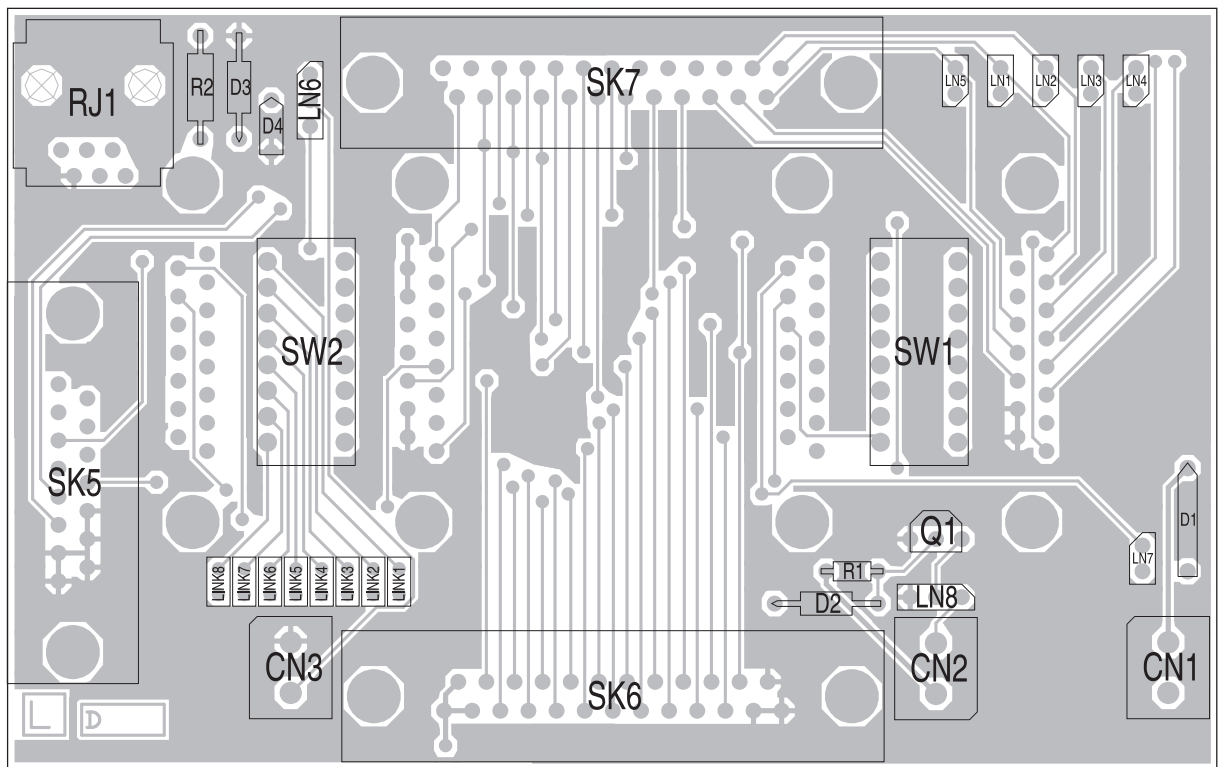
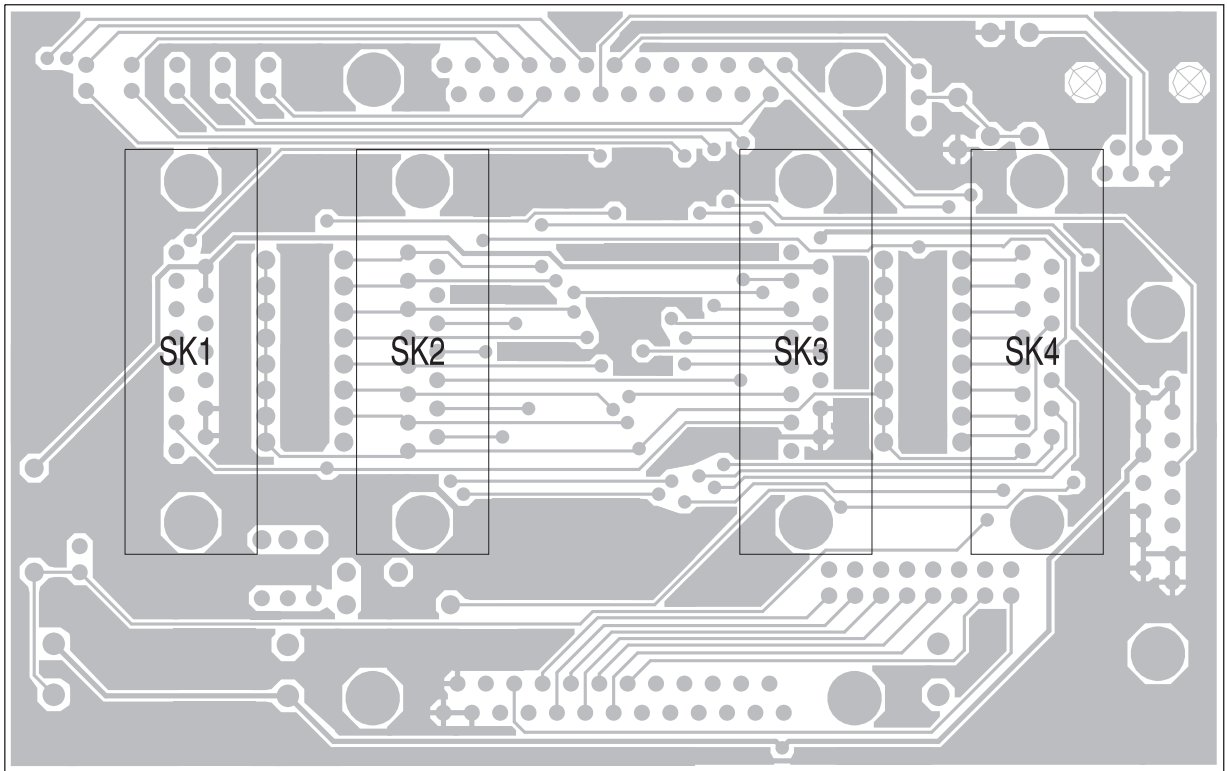

T800-22-0000 PCB (IPN 220-01409-03) - Bottom And Top Sides

## T800 Series II Module Inputs And Outputs

### Receiver : Standard Inputs And Outputs

The table below shows standard inputs and outputs for the T800 receiver and corresponding inputs and outputs on the backplane PCB (SK7).

Signal	DR1 Pin	BKPL (SK7)	I/P O/P	Function
Line O/P	1-4	1-4	O/P	Audio output from a 600Ω balanced line transformer. Output level adjustable from -50 to +10dBm via a potentiometer on the front panel. Pins 2 & 3 are usually linked for normal operation.
RSSI	5	5	O/P	Receiver Strength Signal Indicator. Provides a DC voltage proportional to the signal strength of the received signal. Values are: VHF 4.5V @ -100dBm; 1V/15dB (-115 to -70dBm) UHF 2V @ -110dBm; 1V/10dB (-115 to -70dBm). For UHF, optional board must be fitted.
Audio 1	6	6	O/P	Audio 1 allows access to audio before it passes through the squelch circuitry. The output will provide frequencies down to 5Hz when the audio processor is linked for flat response. From Audio 1, audio can be passed to external CTCSS and signalling decoders.
Serial Com/ Audio 2	7	7	I/O	Serial programming input for programming the module. Can be configured as Audio 2 by internal link resistors if required. Audio 2 is an input and when used in conjunction with Audio 1 allows the audio path to be broken so that external audio processing can be used.
Speaker	8	19	O/P	Provides up to 1W into a 4Ω speaker.
Supply Voltage	9-10	-	I/P	DC Supply Voltage input. Nominal 13.8V, can operate from 10.8 to 16V DC.
Gate O/P	11	14	O/P	Pulls low when a signal is received. In a repeater, configuration can be used to key the transmitter by directly connecting it to the Tx Key pin.
Receiver Gate Relay	12 13	15 16	O/P	Relay Common Relay Normally Open A normally open relay contact that closes when a signal is received. The relay will only operate when PL270 is linked.
Ground	14-15	-	I/P	Power supply earth, negative ground.



## Receiver : Additional Inputs And Outputs

The table below shows additional inputs and outputs for the T800 receiver and corresponding inputs and outputs on the backplane PCB (SK6).

Signal	DR2 Pin	BKPL (SK6)	I/P O/P	Function
Channel Select 0-6	1	22	I/P	External channel select pins (including Channel Select 7 on pin 11). Normally high, these pins are pulled low to select logic 0. To select a channel the binary equivalent must be applied to the pins. when all pins are left floating (i.e. high) then the selected channel is determined by software (PGM800Win).  Note: When using external channel selection, pin 11 must be pulled low.
	2	9		
	3	21		
	4	8		
	5	20		
	6	7		
	7	19		
Ground	8	6	I/P	Power supply earth, negative ground.
Rx Disable	9	18	I/P	When pulled low disables receiver audio output. Usually used in a base station application to ensure there is no interference when the transmitter is operating.
CTCSS Disable	10	5	I/P	Disables CTCSS (Continuous Tone Controlled Squelch System).
Channel Select 7	11	23	I/P	Function as for other channel select lines. Must be pulled low when using external channel selection.
Serial Comm	12	24	I/O	Serial programming input for programming the module. Can be used if it is not possible to program the radio from D-range 1.
Aux-Out 0-2	13	15	O/P	Open drain type; capable of sinking 2.25mA via 2k2Ω; $V_{ds}$ max.=5V. Logic state can change when the channel is changed.  User definable by using PGM800Win software.
	14	10		
	15	11		

## Transmitter/Exciter : Standard Inputs And Outputs

The table below shows standard inputs and outputs for the T800 transmitter/exciter and corresponding inputs and outputs on the backplane PCB (SK7).

Signal	DR1 Pin	BKPL (SK7)	I/P O/P	Function
Line I/P	1-4	22-25	I/P	Audio input to a 600Ω balanced line transformer. For an unbalanced line connect the line I/P 4 to ground. Accepts audio levels as low as -30 dBm. Pins 2 & 3 are usually linked for normal operation.
Tx Enable	5	21	O/P	Pulls low when the transmitter is keyed. Usually connected directly to Tx Key on the PA to activate the PA alarm circuitry.
Audio 2	6	20	I/P	Audio 2 allows audio to be input to the audio processor bypassing the 600Ω line transformer. Ideal place to re-inject audio such as a voice scrambler after external processing.
Serial Com/ Audio 1	7	7	I/O O/P	Serial programming input for programming the module. Can be configured as Audio 1 by internal link resistors if required. Audio 1 allows access to the audio directly after the 600Ω line transformer. When used in conjunction with Audio 2 it allows the audio path to be broken so that external audio processing can be used.
CTCSS	8	18	I/P	An external input for CTCSS or DCS (Digital Coded Squelch).
Supply Voltage	9-10	-	I/P	DC Supply Voltage input. Nominal 13.8V, can operate from 10.8 to 16V DC.
Opto Keys	11 (+) 12 (-)	9 8	I/P	A high isolation keying option. A DC voltage between 6V and 50V applied to these inputs will key the transmitter. The inputs may be used to key the transmitter via a DC remote.
Tx Key	13	17	I/P	A high impedance input which is pulled low to key the transmitter. Must be <0.7V or connected directly to Ground.
Ground	14-15	-	I/P	Power supply earth, negative ground

## Transmitter/Exciter : Additional Inputs And Outputs

The table below shows the additional pin inputs and outputs for the T800 transmitter/exciter and corresponding inputs and outputs on the backplane PCB (SK6).

Signal	DR2 Pin	BKPL (SK6)	I/P O/P	Function
Channel Select 0-6	1	22	I/P	External channel select pins (including Channel Select 7 on pin 11). Normally high, these pins are pulled low to select logic 0. To select a channel the binary equivalent must be applied to the pins. When all pins are left floating (i.e. high) then the selected channel is determined by software (PGM800Win).  Note: When using external channel selection, pin 11 must be pulled low.
	2	9		
	3	21		
	4	8		
	5	20		
	6	7		
	7	19		
Ground	8	6	I/P	Power supply earth, negative ground.
Tx Relay Drive	9	18	I/P	Used for coaxial relay switching. Pulls to ground when the transmitter is keyed.
CTCSS Disable	10	17	I/P	Disables CTCSS (Continuous Tone Controlled Squelch System).
Channel Select 7	11	23	I/P	Function as for other channel select lines. Must be pulled low when using external channel selection.
Serial Comm	12	24	I/O	Serial programming input for programming the module. Can be used if it is not possible to program the radio from D-range 1.
Aux-Out 0-2	13	16	O/P	Open drain type; capable of sinking 2.25mA via 2k2Ω; V <sub>ds</sub> max.=5V. Logic state can change when the channel is changed.  User definable by using PGM800Win software.
	14	4		
	15	3		

## Power Amplifier : Standard Inputs And Outputs

The table below shows the additional pin inputs and outputs for the T800 power amplifier.

Signal	DR1 Pin	BKPL (SK7)	I/P O/P	Function
Supply Voltage	1-2	-	I/P	DC Supply Voltage input. Nominal 13.8V, can operate from 10.8V to 16V DC. Connected to pins 9, 10 and 11.
Forward Power Alarm	3	10	O/P	These are normally low and float if forward power drops below, or reverse power rises above, pre-set limits. They have a 500mA sink capability. A signal is only provided when the Tx Key line on the PA is being pulled low.
Reverse Power Alarm	4	11	O/P	
Forward Power Metering	5	12	O/P	Voltage outputs proportional to the levels of forward and reverse power are available at these pins for metering purposes. There is enough output to drive a coil meter.
Reverse Power Metering	6	13	O/P	
Ground	7-8	-	I/P	Power supply earth, negative ground. Connected to pins 13, 14 and 15.
Supply Voltage	9-11	-	I/P	Function as for Pins 1 and 2.
Tx Key	12	21	I/P	Keys the PA when ground is applied. This line is usually taken to the Tx Enable line on the Exciter.
Ground	13-15	-	O/P	Power supply earth, negative earth.

### 3.3 T800-22-0000 Rack Frame Parts Lists

This section contains the following information.

<b>Section</b>	<b>Page</b>
<b>Mechanical And Miscellaneous Parts</b>	<b>3.3.3</b>
<b>T800-22-0000 Base Station/Repeater Rack Frame</b>	<b>3.3.5</b>
<b>Standard T800-22-0000 Rack Frame With Backplane PCB Mechanical Assembly</b>	<b>3.3.6</b>
<b>Standard T800-22-0002 Rack Frame Without Backplane PCB Mechanical Assembly</b>	<b>3.3.7</b>
<b>Blank Guide Kit Mechanical Assembly (T800-40-0001)</b>	<b>3.3.8</b>
<b>Double Guide Kit Mechanical Assembly (T800-41-0002)</b>	<b>3.3.9</b>
<b>PA Guide Kit Mechanical Assembly (T800-45-0000 &amp; T800-45-0001)</b>	<b>3.3.10</b>
<b>Power Supply Guide Kit Mechanical Assembly (T800-44-0000)</b>	<b>3.3.11</b>
<b>Speaker/Programming Port Mechanical Assembly (T800-15-0000)</b>	<b>3.3.12</b>



## T800-22-0000 Mechanical &amp; Miscellaneous Parts

IPN	Legend	Description	IPN	Legend	Description
001-00011-60		S/DIODE SR2607 Soldered to plug 15way D-Range 240-00020-55	353-00010-13		WSHR M3 S/PROOF INT BZ Speaker front panel
201-00030-03		WIRE T/C 7/0.2 PVC ORANGE 295mm PA to Backplane	353-00010-16		WSHR M3 FIBRE 8MM OD X 1.5MM Speaker front panel
201-00030-04		WIRE T/C 7/0.2 PVC YEL 297mm PA to Backplane	365-00011-54		LABEL R1556/2 90*24MM
201-00030-05		WIRE T/C 7/0.2 PVC GRN 295mm PA to Backplane	365-01371-00		LABEL RACKFRAME 110X145MM
201-00030-06		WIRE T/C 7/0.2 PVC BLUE 293mm PA to Backplane	369-00010-14		TIE CABLE NYLON 100*2.6MM
201-00030-07		WIRE T/C 7/0.2 PVC VIOLET 297mm PA to Backplane	369-00010-14		TIE CABLE NYLON 100*2.6MM
201-00030-08		WIRE T/C 7/0.2 PVC GREY Speaker to programming port connector	369-00010-20		TIE CABLE NYLON SPIRAL 6MM ST6
201-00030-10		WIRE T/C 7/0.2 PVC BLACK Speaker to programming port connector	369-00010-24		BASE CABLE TIE MTG S/AD
201-00050-25		AUTO 154 RED 41/0.3 PVC 350mm PS to Fuse 350mm Fuse to PA socket 300mm PA to Backplane	399-00010-51		BAG PLASTIC 75*100MM
201-00050-26		AUTO 154 BLACK 41/0.3 PVC 550mm PS to PA socket 300mm PA to Backplane	399-00010-53		PLASTIC BAG 150X250MM
205-00010-42		CABLE 6W OVAL TELE INT COLOURS Programming port to backplane PCB connector	410-00002-10		PKG T291/2 OUTER CARTON
220-01410-00		PCB RJ11 B/HD RACK SER II Connects cable from programming port to backplane PCB	410-00002-21		PKG POLYST T800 RACK-FRAMES
240-00020-08		PLUG MODUL PHONE 6W OVAL CABLE Connects cable to backplane PCB			
240-00020-53		PLUG 6 W 2*3 FLAT CABLE TERMN Programming port/speaker to backplane PCB connector			
240-00020-55		PLUG 15 W D RANGE PNL MTG105 C Connects to SK5			
240-02010-54		SKT 15W DRANGE PNL MTG 125 C PA/SK5 cable			
240-04020-53		SKT 6 W 2 R (3X2) PCB MTG Speaker panel/programming socket/ PCB connector			
240-04023-00		SOCKET RJ11 BULK HEAD Connects programming cable			
240-06010-14		CLAMP LATCHING 15 W D RANGE D-range cover			
250-00010-19		SPKR A3M2520			
265-00010-67		FUSE 30A 6X32MM SLOW BLOW			
307-01015-01		GRILLE SPKR 307-01015-00 BLK			
316-06616-00		PNL FRT SPKR SINGLE SER II			
316-80002-00		PACKING A4M1752 PROTECT FOAM			
345-00040-11		SCRW M3X10MM P/POZ ST BZ Holds backplane PCB onto rack frame			
345-00040-20		SCRW M3*8MM BUTTON SKT HD Holds speaker grill onto front panel			
352-00010-08		NUT M3 COLD FORM HEX ST BZ Speaker front panel			

**Note 1:** This parts list contains all those parts not listed on the drawings which follow.

**Note 2:**

Replace 345-00040-11 Screw M3x10 mm p/poz  
With 349-00020-36 Screw TT M3x8 mm  
Pan Torx

Reason Smaller screw now required.

Add 360-00010-05 Grommet 5/8 inch plastic  
Reason Not previously included





Insert A3 T800-22-0000 Base Station/Repeater Rack Frame A3

Insert A3 T800-22-0000 With PCB drawing

Insert A3 T800-22-0000 Without PCB drawing

IPN/ Product Code	Legend	Description
307-02046-00	1	Guide, Blanking
316-06615-00	2	Blank Panel
349-00020-33	3	M3x6 CSK Pozi Taptite
349-00020-36	4	M3x8 Pan Torx Taptite

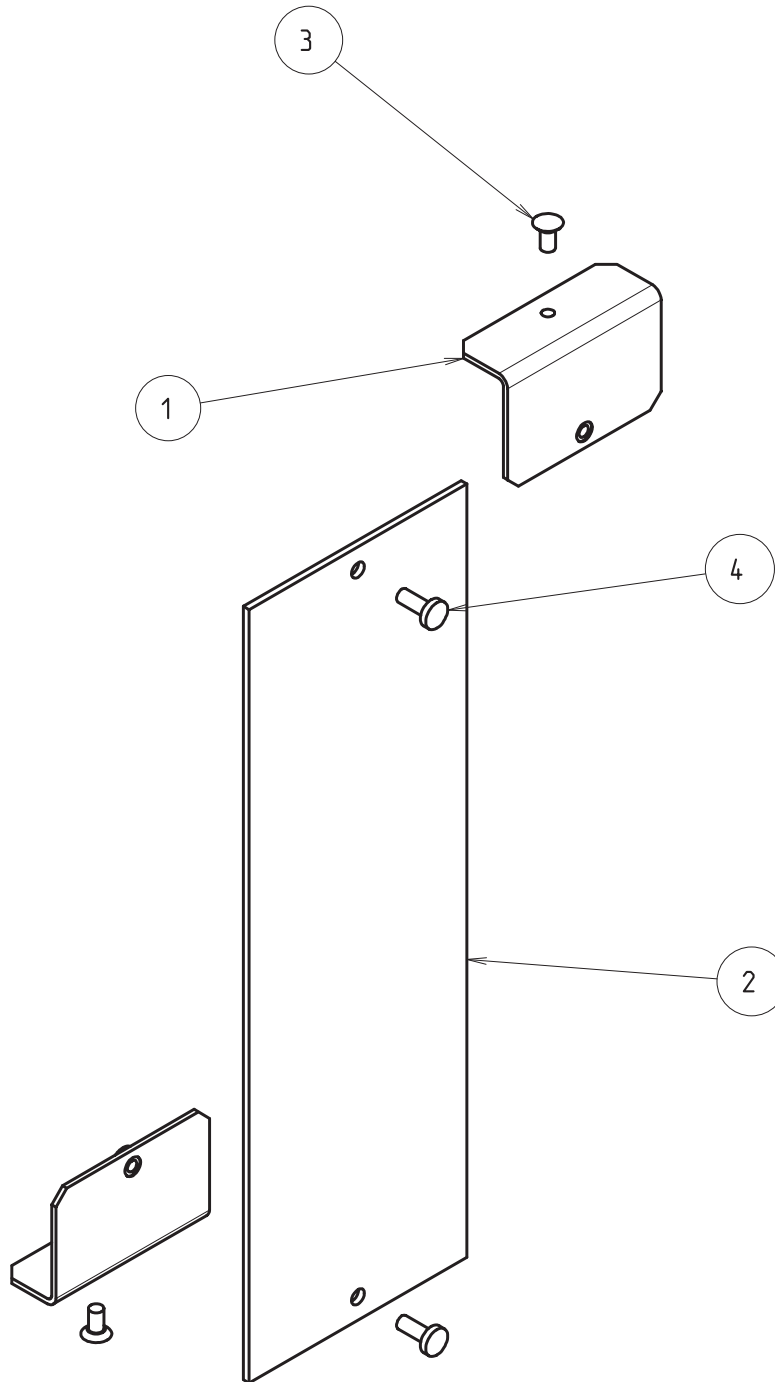

**T800-40-0001 Blank Guide Kit  
Mechanical Assembly**

IPN/ Product Code	Legend	Description
307-02045-00	1	Guide, T800 Module
316-21189-00	2	Rear Panel, Double
349-00020-06	3	4-40x1/4 Pan Pozi Taptite
349-00020-33	4	M3x6 CSK Pozi Taptite
349-00020-36	5	M3x8 Pan Torx Taptite

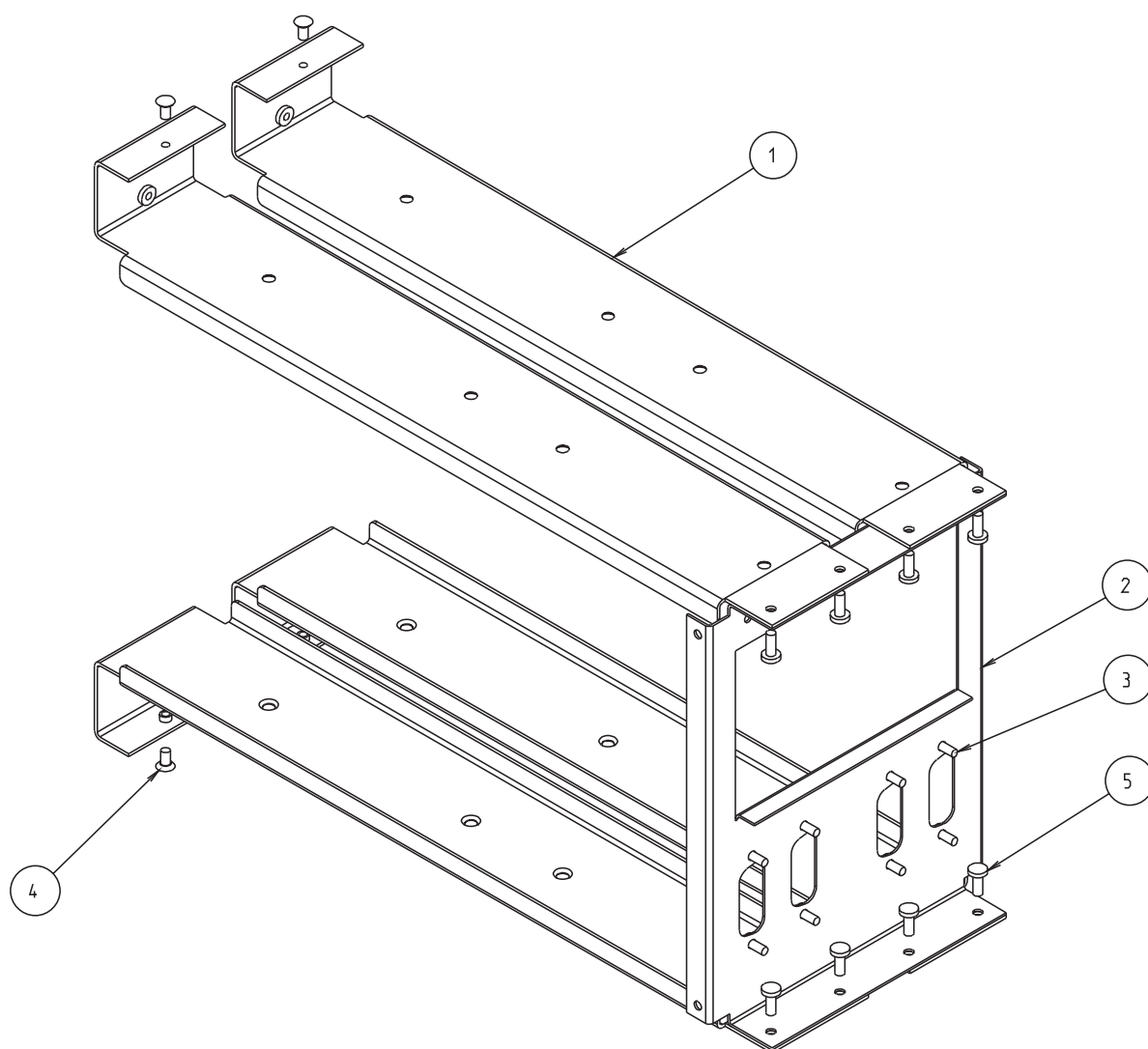

**T800-41-0002 Double Guide Kit  
Mechanical Assembly**

IPN/ Product Code	Legend	Description
307-02042-00	1	Guide, PA Stop
307-02043-00	2	PA Guide Rail
307-02046-00	3	Guide, Blanking
349-00020-33	4	M3x6 CSK Pozi Tapite

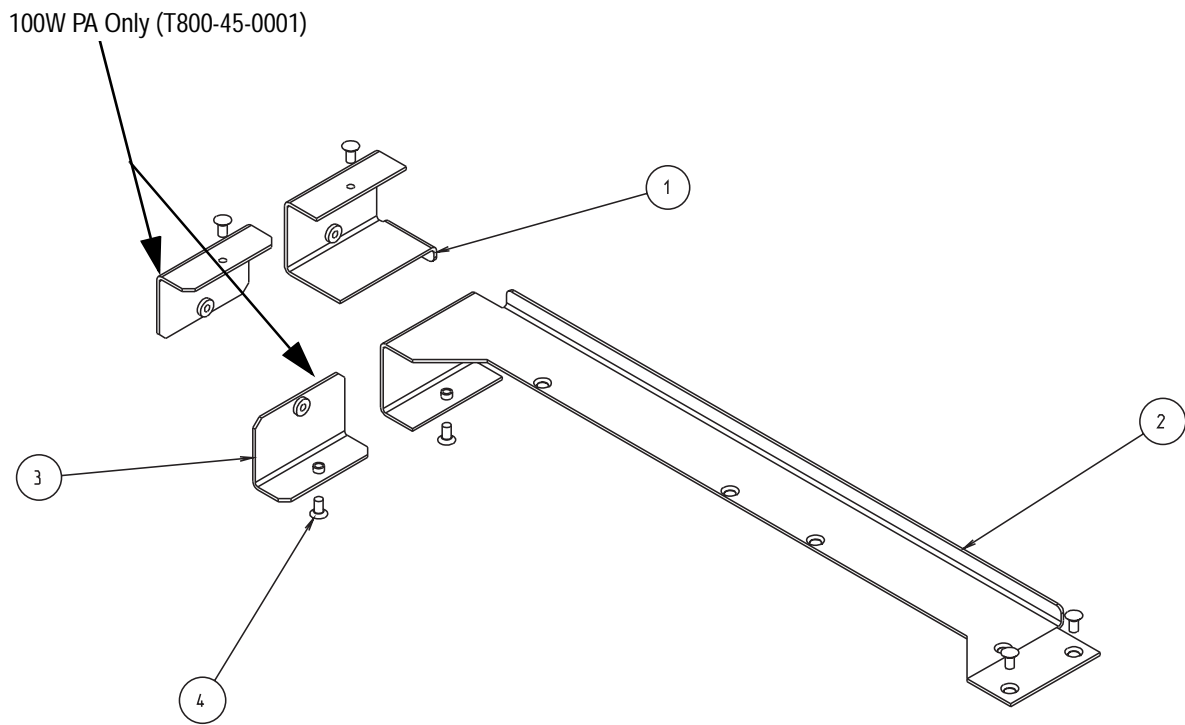

**T800-45-0000 PA Guide Kit  
Mechanical Assembly**

IPN/ Product Code	Legend	Description
307-02044-00	1	Guide, Power Supply
345-00040-09	2	M3x6 CSK Pozi

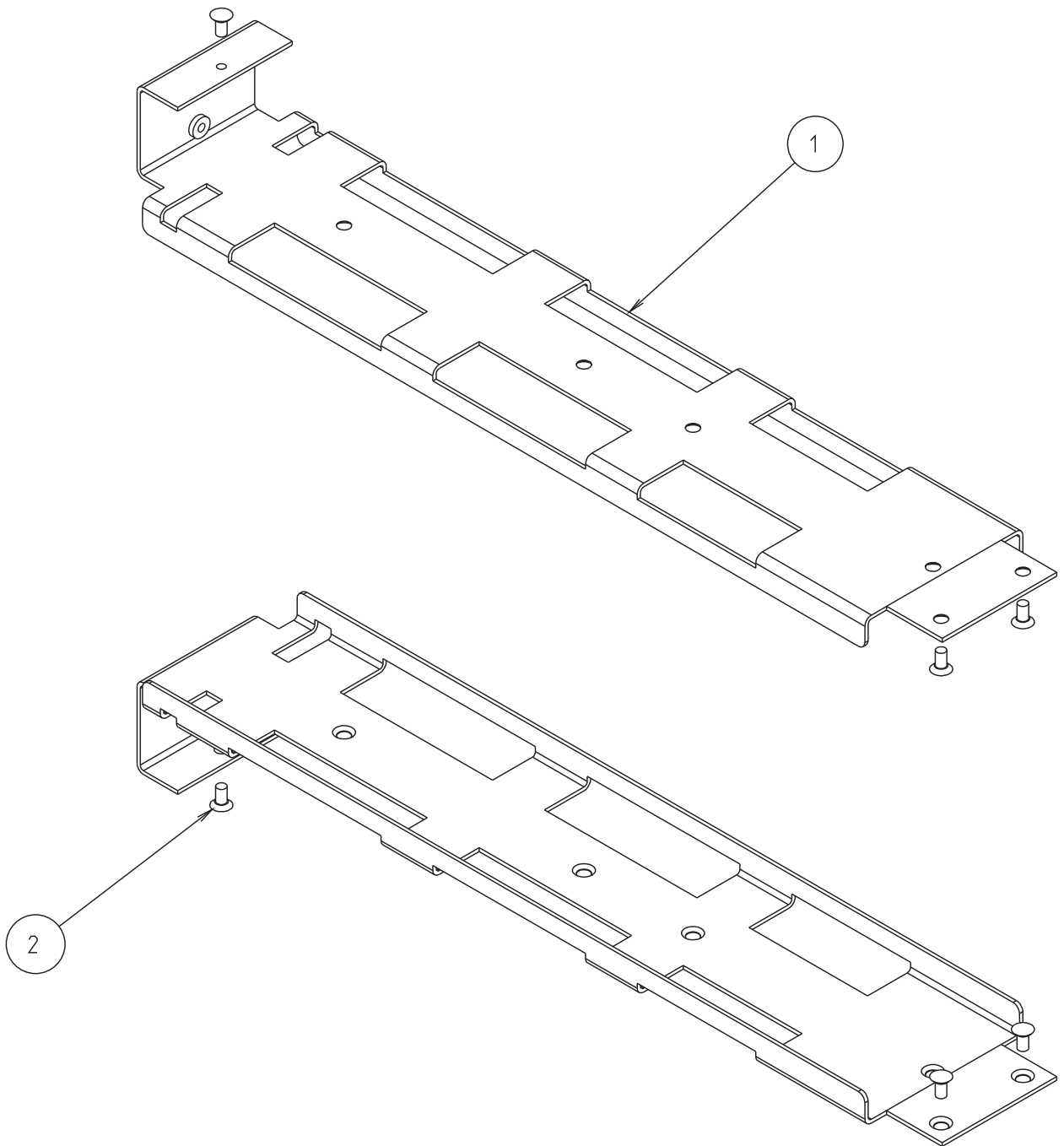

**T800-44-0000 Power Supply Guide Kit  
Mechanical Assembly**

IPN/ Product Code	Legend	Description
220-01410-00	1	PCB RJ11 Bulkhead
240-04023-00	2	Socket RJ11 Bulkhead
250-00010-19	3	Speaker, 4 Ohm 5 Watt
307-01015-01	4	Speaker Grille, Metal
316-06616-00	5	Speaker Panel
349-00020-36	6	M3x8 Pan Torx Taptite
352-00010-08	7	M3 Cold Form
353-00010-13	8	M3 Shakeproof Int
353-00010-16	9	M3 Fibre Washer 1.5T

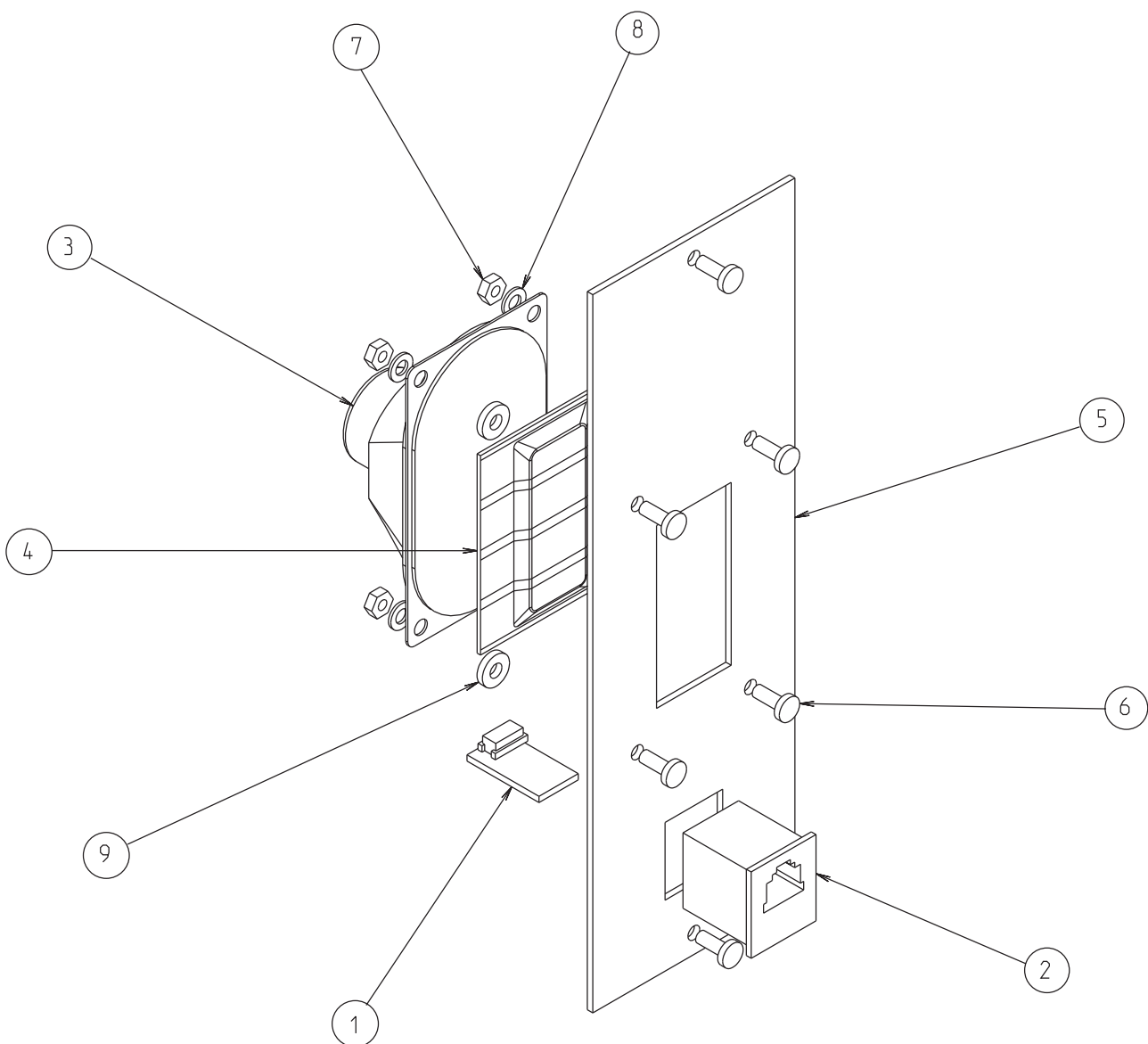

**T800-15-0000 Speaker/Programming Port  
Mechanical Assembly**