

Regency Land Mobile, Inc.

SERVICE MANUAL



SYNTHESIZED VHF TRANSCEIVERS

RH250 · RH256 · WH2516

LIST OF ILLUSTRATIONS

<u>Figure</u>	<u>Section</u>	<u>Title</u>	<u>PAGE</u>
1	1	Equipment Supplied	7
2	1	Control Panel	8
3	2	Mic Matching Network	20
4	2	Block Diagram	28
5	2	BCD Seven-Segment Decoder	33
6	2	WH2516 Reset Circuit	35
	2	Circuit Tie Points	42
	2	Tuning Points	43
	2	Control Board	44
	2	VCO Board	45
	2	P.A. Board	46
	2	Main Board, Parts Placement	47
	2	Main Board, Parts Overlay	48
	2	Main Board, Parts Placement, Bottom Side	49
	2	Schematics	51 53 55
		Program Reference Card	last page

SECTION 4	APPENDICES		
	Appendix A	Alphabetic Listing of Abbreviations used in Service Manual	80
	Appendix B	Description of Terms used in Manual	81
	Appendix C	10 and 16-Channel Programming Reference Card	83
SECTION 5	SERVICE BULLETINS		85

TABLE OF CONTENTS

		<u>PAGE</u>
SECTION 1	DESCRIPTION	
	1-1 Introduction	1
	1-2 Specifications	2
	1-3 System Considerations	5
	1-4 Equipment Supplied	7
	1-5 Equipment Not Supplied	8
	1-6 Operation	8
	RH250 Receiver Operation	10
	WH2516 Receiver Operation	12
	Transmitter Operation	14
SECTION 2	SERVICE INFORMATION	
	2-1 Installation	15
	2-2 Alignment	15
	Programming the Radio	15
	Transmitter Alignment	20
	Receiver Alignment	23
	2-3 Initial Tests	26
	2-4 Circuit Descriptions	26
	2-5 Troubleshooting	36
	2-6 Diagrams, Voltage Data, and Schematics	41
	(see List of Illustrations)	
SECTION 3	PARTS LISTS	
	3-1 Control Board	58
	3-2 VCO/Filter Board, "B" Model	59
	3-3 P.A. Board, "B" Model	62
	3-4 Main Board	
	3-4-1 Receiver Section	64
	"B" Model	
	3-4-2 Transmitter Section	69
	"B" Model	
	3-5 WH2516 Part Variations	74
	3-6 Chassis Parts and Miscellaneous	75
	3-7 "A" Model Part Variations	76
	3-8 "C" Model Part Variations	77
	3-9 "UK" Model Part Variations	78

Copyright 1987 by Regency Land Mobile, Incorporated.
 Duplication prohibited.

SECTION 1 - DESCRIPTION

1-1 INTRODUCTION

This manual was written for the Regency Model RH250 and Wilson Model WH2516 transceivers but is also applicable to the Regency Model RH256. Except for the case and front panel, the RH256 and WH2516 are identical, and "RH256" can be substituted wherever "WH2516" appears. This manual supersedes Service Manual 0300-4323-400.

The RH250 and WH2516 are synthesized transceivers designed to operate in the VHF Land Mobile Communications Band. The RH250 has ten-channel capability and the WH2516 has sixteen-channel capability. A, B, and C frequency ranges and UK (12.5 kHz channel spacing) models are available in both radios.

These radios are programmable by the service technicians. Each is equipped with an electrically alterable read-only memory (EAROM). This device stores the radios' characteristics as programmed using the radios' keyboard. This eliminates the need to order crystals or programmable read-only memories (PROMs) from the factory.

A continuous tone coded squelch system (CTCSS) encoder and decoder are built-in. Any one of thirty-seven tones can be selected for use on any one channel. The sixteen-channel radio can have any two tones out of thirty-seven on one channel. A mixing of tone and non-tone channels may be programmed into the radios along with encode only or decode only channels. The decode only channels require that the transmitter be disabled.

These radios are capable of being programmed for operation in simplex and/or half-duplex systems. Simplex and half-duplex channels can be programmed into each radio, provided that a total frequency separation of 6 MHz is not exceeded between transmit and receive frequencies.

Active channel and priority channel scanners are also standard equipment. The user, under normal operation, simply enters the channels that are to be scanned into a scan list and selects the desired scan function from the keyboard. This is a user programmable feature.

The keyboard is used in radio programming and during normal operation. When the day/night switch is in the night position, the keyboard is illuminated from the back.

General

Channels	
RH250	1 to 10 dealer programmable
WH2516	1 to 16 dealer programmable
Frequency Range	
Model A	134 to 150 MHz
Model B	150 to 162 MHz
Model C	162 to 174 MHz
Model UK	162 to 174 MHz
Channel Spacing	
Models A, B, and C	30 kHz (5 kHz min resolution)
Model UK	12.5 kHz (12.5 kHz min resolution)
Frequency Separation Transmitter/Receiver	6.0 MHz (VCO voltage maintained between 4 and 7.5 VDC)
Operating Temperature	-30° to +65°C -22° to +150°F
Storage Temperature	-50° to + 90°C -59° to +194°F
Case Dimensions	6 1/2" x 2 3/4" x 10 3/4" 16.5 cm x 7.0 cm x 27.3 cm
Weight	4 lbs, 14 ozs 2.2 kg
Operating Duty Cycle	20%; 1 minute transmit 4 minute receive
Antenna Impedance	50 ohms
Supply Voltage	13.8 VDC (negative ground)
Current Drain @ 13.8 VDC Supply Voltage	
Receiver Squelched	500 mA Max*
Receiver Max Audio	1.1 A Max*
Transmitting	5.0 A Max*

*Add 150 mA for operation below 0°C (32°F)

Receiver

Receiver Sensitivity	
12 dB SINAD	0.35 uV (-116 dBm)
20 dB Quieting	0.5 uV (-113 dBm)
Squelch Sensitivity	
Threshold Squelch	0.2 uV (-121 dBm)
Tight Squelch	1.0 uV (-107 dBm)
CTCSS Sensitivity	0.32 uV (-115.9 dBm) w/tone dev. of 750
Adjacent Channel Desensitization 12 dB SINAD Method	70 dB
Operating Bandwidth	3.0 MHz (<u>+1.5</u> MHz)
Image Rejection	70 dB
Spurious Rejection	70 dB
IM 12 DB SINAD	70 dB
Modulation Acceptance Bandwidth	<u>+7.5</u> kHz
Freq Stability Temp	<u>+0.0005%</u> *
Freq Stability Voltage	<u>+0.00005%</u>
Audio Response	per EIA RS204C, Part 9
Audio Distortion @ Rated Power	5%
Audio Power Out	5 W Min
Squelch Blocking	per EIA RS204C, Part 18
Receiver Attack Time (EIA)	150 mSec Max
Receiver Squelch Closing Time (EIA)	250 mSec Max

*Allow 5 minutes warm-up time for ambient temperature below 32°F (0°C).

Receiver (continued)

Hum & Noise Ratio (Squelched)	60 dB Min
Hum & Noise Ratio (Unsquelched)	35 dB Min
Undesired Radiated	per FCC, Part 15, Subpart C

Transmitter

Power Output	25 W Min
DC Power into Final	47 W Max
Output Freq Stability (Temp)	$\pm 0.0005\%$ *
Output Freq Stability (Volt)	$\pm 0.00005\%$
Spurious & Harmonics, Conducted	-57.3 dBc
Spurious & Harmonics, Radiated	Meets FCC requirements for Parts 2, 21, 81, and 90
Operating Bandwidth	5 MHz (± 2.5 MHz)
Emission Designator	16F3
Modulation	Factory set at FCC Max of ± 5 kHz
Audio Freq Distortion	3%
FM Hum & Noise	35 dB Min
AM Hum & Noise	per EIA RS152B, Part 16
Audio Freq Response	per EIA RS152B, Part 7
Transmitter Attack Time	per EIA RS152B, Part 18
Sideband Spectrum	per EIA RS152B, Part 17

*Allow 5 minutes warm-up time for ambient temperatures below 32°F (0°C).

NOTE: All specifications are subject to change without notice.

These radios are designed for CTCSS operation or non-CTCSS operation. It is possible, however, to adapt other tone signaling devices if there is mounting space available.

If another tone signaling device is used, the following circuit connection points and load requirements must be followed:

1. Make audio circuit connection at A0. Load must not be lower than 10K ohms.
2. Use K5 for mic hang-up point. All channels must be programmed for non-CTCSS operation.
3. Power supply connections can be made to P0, P1, P10, or P20. There are no restrictions to the amount of current that can be drawn from the P0 or P1 points, however, the P20 point cannot exceed 10 mA and the P10 point cannot exceed 25 mA. The P10 point is the regulated 5 V supply and P20 is the regulated 9.5 V supply.
4. Use U2 as the transmitter tone modulation input.
5. Use K30 as a carrier detect signal. This is only activated when the squelch control is set to squelch the radio. It is active (+7 V output into 10K ohm load) when a carrier is present.
6. Use D1 to activate the message light. The jumper connecting D1 to Pin 24 of IC403 must be removed.
7. Use A8 as the input for audible alarm. This signal must be padded for the desired alarm level.
8. Connection points are shown on the Option Tie Point Diagram in Section 2-6.

NOTE: The base station microphone has a built-in compression amplifier, therefore no external one is needed when considering system requirements.

If a compression amplifier is desired for use in a component base station use the Split Bar Desk Microphone with built-in Compression Amplifier.

In installations where prohibitive AC ripple is present on the power supply lines use the Alternator Whine Filter to cut out the ripple to the radio. Check with the installation section to review the proper installation practices.

The radios' operating bandwidth is specified at 3.0 MHz for the receiver and 5.0 MHz for the transmitter. Typical units normally run 3.5 MHz and 6.0 MHz respectively. With careful tuning, the radios' performance may be optimized for wideband operations. WARNING: MAINTAIN THE VCO VOLTAGE (PIN 6 OF IC502) BETWEEN 4.0 VDC AND 7.5 VDC.

If the radios are to be used as part of a component base station, DO NOT PLACE THE RADIO ON TOP OF, OR ADJACENT TO, THE AC POWER SUPPLY. Locate the radio far enough away from the power supply so there is no magnetic coupling between them.

1-4 EQUIPMENT SUPPLIED

1. Radio
2. Hand Microphone
3. Hardware Kit No. 2
4. Mounting Bracket
5. Two (2) Black Anti-Rotation Washers
6. Two (2) Steel Washers
7. Two (2) Mounting Stub-Knobs
8. DC Power Cord w/5 A Fuse

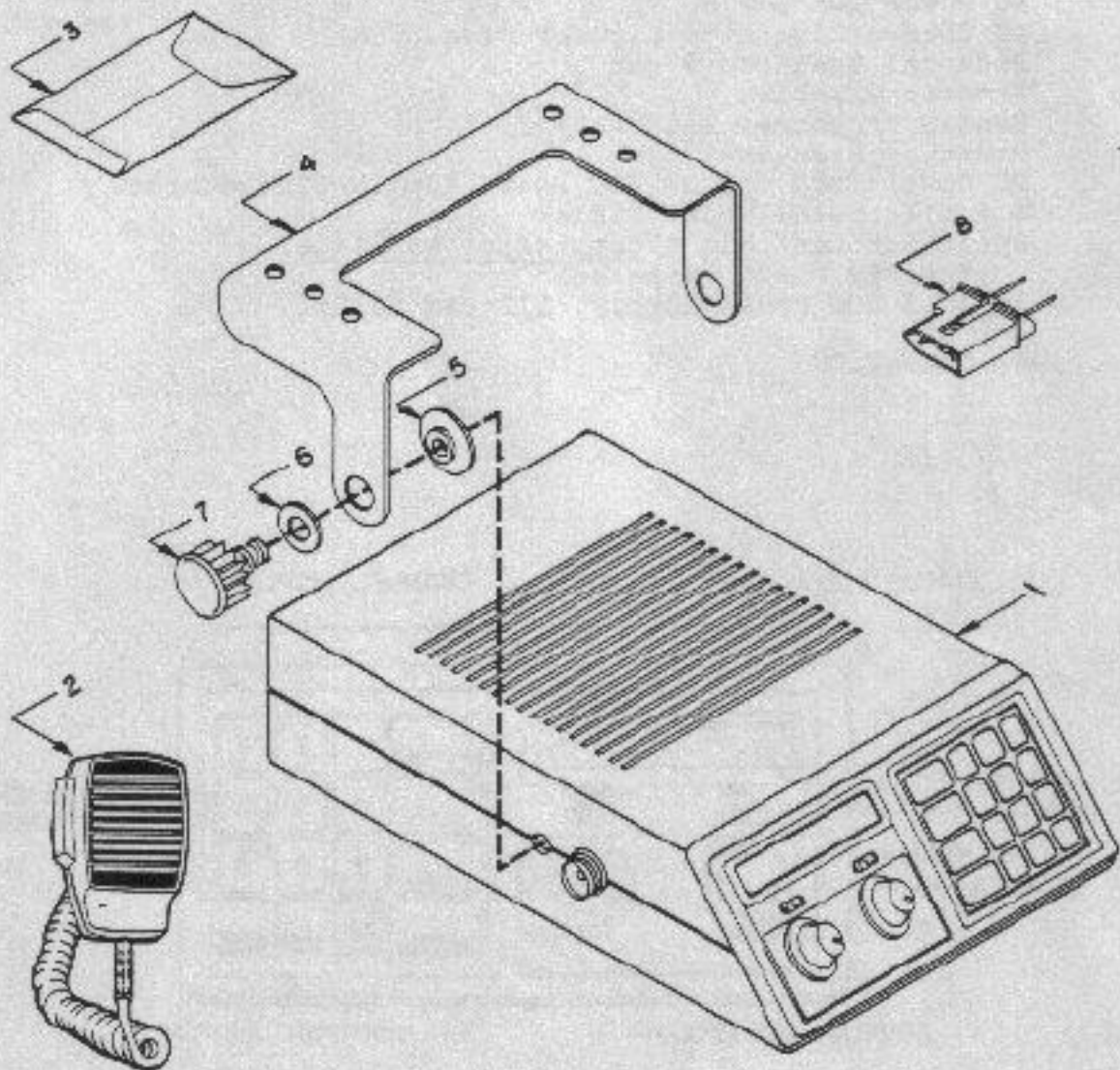

FIGURE 1 - EQUIPMENT SUPPLIED

1-5 EQUIPMENT NOT SUPPLIED

1. Antenna
2. Antenna Feed Cable
3. 13 V Supply

External Options Available

- Quick Mount Thumb Bolts (stud-knobs)
- 5 W Horn Speaker
- Handset and Cradle (5-pin)
- Hand Microphone, Black (5-pin)
- DC Power Cord, 5 A
- DC Cord w/Cigarette Lighter Plug, 5 A
- External Speaker, 8 ohm
- Handset w/Switch
- Hand Microphone, Beige (5-pin)
- Mounting Bracket
- DC Power Cord for 13 VDC Power Supply listed below
- 6 A Alternator Whine Filter
- Split Bar Desk Mic w/Compressor Amplifier
(specify black or beige)
- 12 A 13 VDC Power Supply, 117 VAC 60 Hz

1-6 OPERATION

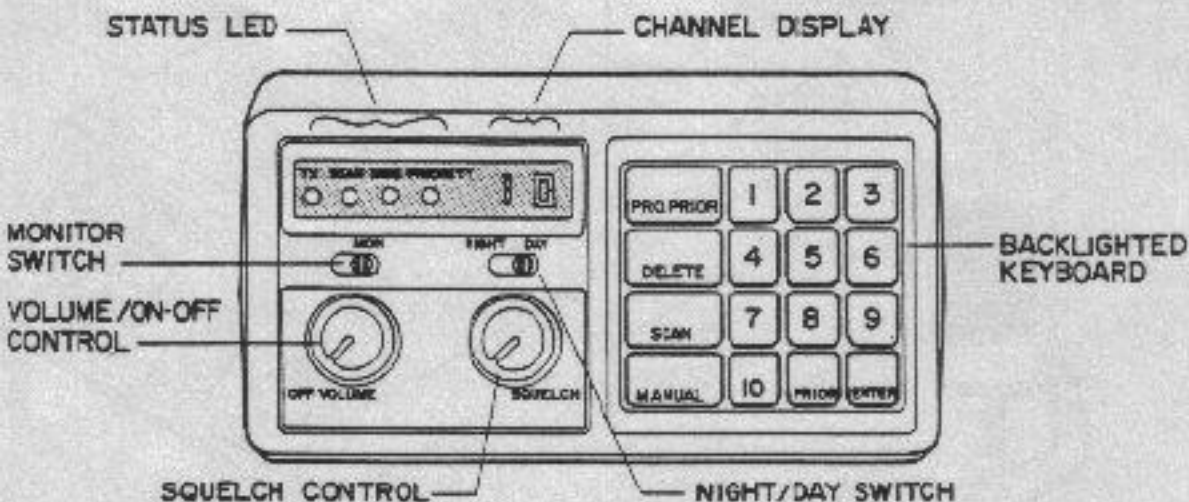

FIGURE 2 - CONTROL PANEL

(Refer to Figure 2 for the following descriptions.)

VOLUME CONTROL/ON-OFF SWITCH

This control varies the speaker volume. Clockwise rotation turns the radio on and increases the volume. The RH250 powers up on the priority channel. When turned off and back on, it will revert back to the priority channel, i.e. the radio will not remember the state it was in before being switched off. The WH2516 will, however, remember the state it was in before being switched off.

SQUELCH CONTROL

The squelch control is used to eliminate the speaker noise when not receiving a transmission. Move the control clockwise until noise is heard. If in the SCAN mode the receiver will stop scanning. Then move the control counterclockwise until the speaker noise is squelched. If in the SCAN mode the receiver will start to scan approximately two seconds after the speaker squelches.

MONITOR SWITCH

Placing this switch in the "MON" position allows the user to monitor the channel when the CTCSS decoder is operating.

NIGHT/DAY SWITCH

Placing this switch in "DAY" position places the display lights at maximum brightness and does not light the keyboard. In the "NIGHT" position the display light's brightness is decreased and the keyboard is illuminated.

STATUS LEDs

There are four status LEDs located to the left of the channel display.

TX - When lit indicates that the transmitter is activated. This is accomplished by removing the microphone from the hang-up clip (off-hook condition) and pressing the push-to-talk switch on the microphone.

SCAN - When lit or flashing indicates that the radio is in the SCAN mode. Pressing the SCAN button on the keyboard puts the radio in the SCAN mode.

MSG - When lit indicates that a message has been received. The radio's CTCSS decoder must be activated in order for this LED to function. If a message has been received, going off hook or changing the channel will reset the LED to its OFF state.

PRIOR - When lit indicates that the radio's priority function has been selected. Pressing the PRIOR button on the keypad will activate or deactivate the PRIORITY function.

CHANNEL DISPLAY

Displays the current channel the radio is operating on. The channels are selected by pressing the appropriate button(s) on the keyboard.

RH250 RECEIVER OPERATION

There are two receiver operating modes, manual and scan. The radio powers-up in the manual mode on the priority channel.

Manual Mode:

The manual mode is entered by pressing the MANUAL button or any of the channel buttons (1-10) on the keyboard. The scan LED is extinguished. The radio operates on the displayed channel.

Scan Mode:

Allows the radio to monitor activity on more than one channel. Pressing the SCAN button on the keyboard will place the radio in the scan mode. The scan LED will be illuminated. The radio will scan the channels placed into the scan list only if the microphone is on-hook (mic hang-up button connected to chassis ground) and the squelch control adjusted to squelch the radio (without a carrier present). With the radio properly set up, the scan LED will blink and the display will turn off while the radio scans. When there is activity on one of the channels in the scan list, the radio will stop on that channel, the scan LED will be held on, and the active channel will be displayed. The radio will go to the priority channel whenever the microphone is lifted off hook. When the microphone is placed back in the hang-up clip, the radio resumes scanning.

Programming the Scan List:

Programming the scan list is a user operation. That is, the radio is not in the program mode for this operation.

Entering a channel into the scan list is accomplished by pressing the channel to be entered and the ENTER button on the keyboard. When the ENTER button is pressed the display will momentarily blink off and then will display the channel just entered in the scan list.

To delete a channel from the scan list press the channel to be deleted and then press the DELETE button on the keyboard. The channel display will blink off and after the channel has been deleted from the list the next channel in the list will be displayed.

If deleting consecutive channels in the scan list, it is not necessary to enter all the channels. The channels can be deleted by pressing the first channel number of the sequence; then press the DELETE button as many times as there are channels to delete. For example: to delete channels 3, 4, and 5 in the scan list, select channel 3 and press the DELETE button three times.

If all the channels have been deleted from the scan list, a flashing "c" will be displayed. The scanner will not operate without at least one channel in the scan list.

To review the channels in the scan list, press the MANUAL button on the keyboard. Each time the MANUAL button is pressed the next higher channel in the scan list is displayed.

The Priority Function:

The priority function allows the operator to listen to one channel (non-priority channel) and not miss an important message on another more important channel (priority channel). Pressing the PRIOR button on the keyboard will enable or disable the priority function. When the priority LED is lit the priority function is enabled.

Whenever the priority function is selected (pressing the PRIOR button results in illumination of the priority LED) the radio will go into the manual mode and jump to the priority channel. When the priority function is disabled (pressing the PRIOR button results in the priority LED turning off) the radio will stay in its operating mode.

To change the priority channel, select the channel to become the priority channel and press the PRO PRIOR and ENTER buttons (in that order) on the keyboard.

Priority-Manual Operation:

The squelch control must be set, squelching the radio, to allow the priority function to operate. When the radio is listening on a non-priority channel it will occasionally look at the priority channel. If the priority channel is active the radio will stop on that channel and monitor the transmission. The radio does this regardless of what is happening on the non-priority channel. When the priority channel becomes inactive and the microphone was not lifted

From the hang-up clip, the radio will return to listen to the non-priority channel it was on before. But if the microphone is lifted, the radio will remain on the priority channel forgetting the non-priority channel it was on previously.

Priority-Scan Operation:

Operation of the radio with the priority function selected in the scan mode is similar to that of the non-priority scan mode with one exception. If the radio stops scanning ("locks up") on a non-priority channel the radio will occasionally look at the priority channel. If there is activity on the priority channel the radio will stay on the priority channel; if not, the radio will go back to the channel that was interrupted.

Lifting the microphone off-hook will cause the radio to stop scanning and go to the priority channel. Upon placing the microphone on-hook the radio will resume scanning.

If a call comes in on a non-priority channel, however, and the microphone is lifted off-hook (causing the radio to jump to the priority channel) the message channel is lost. To prevent this from occurring the user must note the channel the message was on and press that channel button on the keyboard (taking the radio out of the scan mode) and then pick up the microphone.

WH2516 RECEIVER OPERATION

The operation of this radio is similar to that of the RH250. There are two receiver modes, manual and scan. The WH2516, however, powers up to the state the radio was in before the power was turned off. The radio will still do this even after the power connector is disconnected and then reconnected.

Manual Mode:

The manual mode is the same as the RH250 with the exception of selecting channels 11 through 16. Whenever the "1" button is pressed, the display will flash a "1" in the tens position. If a second number is not entered within three seconds the radio will revert to channel 1. If, however, a second button between 1 and 6 is pressed, the radio will select that channel 11 through 16, respectively.

Scan Mode:

The scan mode is similar to that of the RH250. The same conditions are required to scan, that is, adjust the squelch control to squelch the radio; place the microphone on-hook and press the SCAN button on the keyboard. The changes in the scan mode are as follows:

The WH2516 will not jump to the priority channel when answering a call. The only time this will occur is when the radio is scanning (SCAN LED blinking) and the microphone is lifted off hook. This is regardless of the priority function selected.

Scan delay time selections of 0.68, 1.3, and 2.0 seconds are available. After receiving a call, the programmer has the option of selecting one of three time delays before the radio starts scanning. The selection of the delay time is done during radio programming (see Section 2-2).

Programming the Scan List:

Entering, deleting, and reviewing the channels in the scan list are done in the same way as the RH250. Pressing ENTER enters the channel in the list; pressing DELETE deletes a channel from the list, and pressing the MANUAL button reviews the channels in the scan list.

The Priority Function:

The priority function is the same as the RH250's priority function. Press the PRIOR button to activate the priority function; press the PRIOR button again to deactivate it. The WH2516, however, will not jump to the priority channel when activating the priority function. Also, any time the PRIOR button is pressed and held the radio will display the priority channel.

Priority-Manual Operation:

The priority-manual operation of the WH2516 is similar to the RH250 except for the following:

If the radio reverts to a priority channel while listening to a non-priority channel, regardless whether the microphone was lifted off-hook, the radio will go back to the non-priority channel it was on before.

When activating the priority function the radio will stay on the same channel.

Priority-Scan Operation:

The priority-scan operation of the WH2516 is similar to the RH250 except for the following:

When the scanner locks-up on a non-priority channel the radio jumps to the active priority channel; the radio will go back to the non-priority channel before starting the scanner. This occurs even if the microphone was taken off-hook.

The radio will not jump to the priority channel when the priority function is activated but will remain scanning.

TRANSMITTER OPERATION

To transmit, select the desired channel, lift the microphone off-hook, monitor to be sure the channel is not in use, key the transmitter, and speak into the microphone. To key the transmitter press the push-to-talk (PTT) button on the side of the microphone. Two-way conversation is accomplished by the push-to-talk, release-to-listen operation of the PTT button on the microphone. When transmitting a message make the conversation short and clear.

Note that the PTT button on the microphone is not enabled when the microphone is on-hook (microphone hang-up button connected to chassis ground). Also, while transmitting, the keyboard is disabled so accidental pressing of a button on the keyboard will not interrupt the transmission.

The WH2516 has some features not available in the RH250. One is a time-out timer. The timer is to prevent accidental PTT operation from blocking a channel. The available time-outs are 30, 60, and 120 seconds. When programmed (see Section 2-2) the time-out function is enabled on all channels.

Another feature available on the WH2516 is that the transmit CTCSS tone frequency can be different than the receiver decoder tone frequency.

2-1 INSTALLATION

WARNING: THIS UNIT IS DESIGNED TO OPERATE IN VEHICLES WHICH HAVE A 12 VDC NEGATIVE GROUND POWER SUPPLY

Locate the radio in a convenient and accessible area in the vehicle's cab. Secure the mounting bracket and attach the radio. Mount the microphone hang-up clip. The microphone hang-up clip must be grounded to the vehicle's chassis. Connect the microphone.

Route the power cable supplied to the vehicle's battery. Connect the positive (red) lead to the positive (+) terminal on the battery; connect the negative (black) lead to the negative (-) terminal. Be sure to locate the wires away from any noise sources, such as the generator or alternator, ignition wires, etc. If there is not enough wire, splice additional wire to connect the leads to the battery. If the battery is located in an extremely remote location, find a buss connection that can handle a 5 amp current draw. Check this buss connection for ripple on the line. The ripple must be less than 200 mVRMS otherwise an alternator whine filter must be used (or find a better terminal block connection).

Mount the antenna and route the antenna feed cable to the radio. Connect the antenna and make adjustments for best radio-to-antenna match.

NOTE: Any adjustments affecting the transmitter's power output, carrier frequency and/or modulation deviation must be done by a qualified technician.

2-2 ALIGNMENT

Programming the Radio

General:

The RH250 and WH2516 contain a programming jumper. Radio programming can only be accomplished when the radio is in the program mode. To place the radio in this mode follow the directions listed under "Entering the Programming Mode." The directions listed under "Programming" describes the programming procedure for each of the radios. Be sure to follow these procedures exactly otherwise the radio will not perform properly. The radio is programmed using a reverse-polish data entry technique. This is where the data is keyed in first and then entered into the channel memory.

Entering the Programming Mode:

1. Before powering the radio up be sure that the programming jumper, JU401, is installed.
2. Turn on the radio.
3. Enter the programming mode by pressing "PRO PRIOR" "10" on the keyboard. The display will go blank.
4. The radio is now in the program mode. The radio will remain in the program mode until turned off. The radio is now ready to accept programming data. Follow the programming procedure for the particular radio being programmed. When programming is completed, follow the instructions on exiting the program mode.

Programming: (Note - to enter a zero (0) press the ten (10) button on the keyboard.)

1. RH250 Programming

- a. Enter the program node (see "Entering the Programming Mode").
- b. Key in the receiver frequency (6-digit code) in kHz. To enter a 7-digit frequency (RH250UK only) subtract 2.5 kHz from the desired frequency and enter the results. (e.g. for a frequency of 164.6375 MHz enter 164635).
- c. Select the simplex/half-duplex code (1-digit code).
0 = simplex
8 = half/duplex
- d. Select CTCSS/transmitter operation code (1-digit code).
0 = normal RX/TX operation
(CTCSS encoder and decoder enabled if CTCSS tone selected)
2 = Normal RX/TX operation
(CTCSS encoder enabled only if CTCSS tone selected)
4 = RX operation only; transmitter disabled
(CTCSS decoder enabled if CTCSS tone selected)

- e. Key in CTCSS tone code (2-digit code) from the table below:

<u>Code</u>	<u>Frequency</u>	<u>Code</u>	<u>Frequency</u>	<u>Code</u>	<u>Frequency</u>
00	no tone	13	103.5 Hz	26	162.2 Hz
01	67.00 Hz	14	107.2	27	167.9
02	71.90	15	110.9	28	173.8
03	74.4	16	114.8	29	179.9
04	77.0	17	118.8	30	186.2
05	79.7	18	123.0	31	192.8
06	82.5	19	127.3	32	203.5
07	85.4	20	131.8	33	210.7
08	88.5	21	136.5	34	218.1
09	91.5	22	141.3	35	225.7
10	94.8	23	146.2	36	233.6
11	97.4	24	151.4	37	241.8
12	100.0	25	156.7		

- f. If an eight (8) was entered in Step c (half-duplex channel), then key in the transmit frequency in kHz (6-digit code). To enter a 7-digit code (RH250UK only) subtract 2.5 kHz from the desired frequency and enter the results. (e.g. for a frequency of 164.6375 MHz enter 164635).
- g. Press the ENTER button on the keyboard.
- h. Press the channel number the data is to be stored in. The channel number will be displayed after the data is stored.
- i. Program the other channels by doing Steps b through h for each channel.
- j. Delete any unprogrammed channels by pressing the DELETE button on the keyboard followed by pressing the ENTER button and the channel to be deleted. IF deleting more than one channel the DELETE button only needs to be pressed once followed by the ENTER - CHAN. NO. sequence for each channel to be deleted.
- k. Review any channels that might be considered to be improperly programmed (see "Reviewing the Program").
- l. Exit the program mode. Turn the power off. Remove the programming jumper, JU401.

2. WH2516 Programming

- a. Enter the program mode (see "Entering the Programming Mode").
- b. Key in the receiver frequency in kHz (6-digit code). To enter a 7-digit frequency (UK only) subtract 2.5 kHz from the desired frequency and enter the results.
- c. Select the simplex/half-duplex code (1-digit code).
 - 0 = simplex
 - 8 = half/duplex
- d. Select the transmitter operation code (1-digit code).
 - 0 = normal RX/TX operation
 - 4 = RX operation only; TX disabled
- e. Key in the RX CTCSS code from tone table given in l.e. (2-digit code).
- f. Key in the TX CTCSS code from tone table given in l.e. (2-digit code). This step does not have to be done if programming a simplex channel with the same RX and TX tone. The TX tone code must be entered if programming a half-duplex channel.
- g. Key in the TX frequency in kHz (6-digit code) if programming a half-duplex channel. To enter a 7-digit frequency (UK only) subtract 2.5 kHz from the desired frequency and enter the results.
- h. Press the ENTER button on the keyboard.
- i. Press the channel the data is to be entered in. Note that when pressing the "1" button the tens digit on the channel display starts blinking the number 1. It will do this for about three seconds, waiting for a second digit to be entered (for channels 11 through 16). The display reverts to channel 1 if no second digit is entered in the allotted time; channel 1 will then be programmed with the data.
- j. Repeat Steps b through i for all the channels to be programmed.
- k. Delete any unprogrammed channels. Follow the same procedure described in l.j.

1. Key in the scan delay code (1-digit code) from table below:

	<u>Code</u>	
Scan Delay	WH2516A,B,C	WH2516UK
0.680 sec	0	1
1.3 sec	2	3
2.0 sec	4	5

- m. Key in the Time-Out-Timer code (1 digit) from the table below:

<u>Time Out</u>	<u>Code</u>
NO time out	0
30 sec	1
60 sec	2
120 sec	4

- n. Key in the External Decoder Interrupt Delay code from the table below:

<u>Decoder</u>	<u>Delay</u>	<u>Code</u>
Built-In CTCSS	0	0
External	100 ms	1
External	200	2
External	300	3
External	400	4
External	500	5
External	600	6
External	700	7
External	800	8
External	900	9

NOTE: When using external decoder consult the factory.

- o. Press the ENTER button on the keyboard.
- p. Press the SCAN button on the keyboard.
- q. Exit the programming mode by turning off the radio and removing the programming jumper, JU401.

Reviewing the Program:

1. Before the channels can be reviewed, the radio must be in the programming mode. If the radio is already in the programming mode then continue on to Step 2; if not, follow the procedure in "Entering the Programming Mode."
2. Reviewing the program for the channels is the same for both models, RH250 and WH2516.
 - a. Press the MANUAL button on the keyboard.

- b. Press the channel number to be reviewed. Note that when reviewing channel 1 on the WH2516, a 1 will flash in the tens digit. This is not part of the channel's program; the radio is just waiting for the second digit entry for channels 11 through 16.

The radio will display, using the one's digit on the channel display, the programmed data for the selected channel. Each data digit is displayed for two seconds, starting with the receiver frequency through to the transmitter frequency in the same order the channel was programmed.

3. Reviewing the radio configuration (WH2516 only)

- a. Press the MANUAL button on the keyboard.
- b. Press the SCAN button on the keyboard.

The one's digit on the channel display will display in order: the scan delay code, the time-out-timer code, and a zero, in that order (each code displayed for two seconds).

Transmitter Alignment

Equipment Required:

1. Termliner Wattmeter or Through-line Wattmeter with a termination into 50 ohm dummy load
2. Frequency Counter with an accuracy of ± 100 Hz
3. FM Deviation Monitor
4. DC Voltmeter with 1 megohm input impedance
5. Hex head and small straight blade alignment tools
6. Mic Matching Network (shown in Figure 3)
7. Audio Generator
8. Power Supply

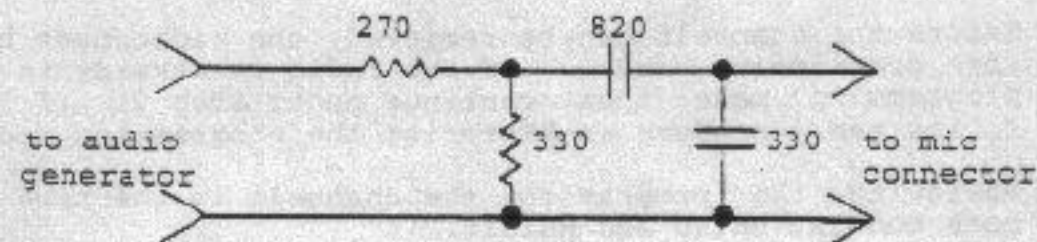

FIGURE 3

Pre-Alignment Procedure: (radio plugged in and operating)

1. Set the cores of L501, L502, L503, and L504 flush with the top of the coil form.
2. Connect the DC Voltmeter between Pin 6 of IC502 and ground (this point is also accessible at the connection of the green wire and R201 on the VCO Board).
3. Select the highest frequency (receive or transmit, whichever is highest) and tune L201 for 7.5 V on the Voltmeter (use the access hole on chassis side).
4. Select the lowest frequency. Be sure the voltage on the Voltmeter does not drop below 4 volts. If these voltages are exceeded then the transceiver's specifications cannot be guaranteed.
5. Adjust R560 to the most counterclockwise position.
6. Disconnect the Voltmeter and continue on to the Transmitter RF Alignment Procedure.

Transmitter RF Alignment Procedure:

1. Connect the DC Voltmeter between M5 and ground.
2. Calculate the mathematical center of the transmit frequencies. If a channel is not programmed within +100 kHz of the mathematical center, program one.
3. Connect the power meter to the antenna port making sure the line is terminated into 50 ohms.
4. Connect the Mic Matching Network and connect the Audio Generator to the Matching Network. Set the Generator to 1 kHz with an output of 0 volts.
5. Key the transmitter and tune L501 and L502 for peak voltage on the Voltmeter. Tune L503 for a voltage dip on the Voltmeter. Tune L504 for peak voltage on the Voltmeter. Power should register on the power meter. If not, tune C307 for a power reading. This voltage will be about 0.5 V. Unkey transmitter.
6. Key the transmitter momentarily for each of the following adjustments:

Adjust C301, C307, C311, and C313 for maximum output power.

Retune L501 and L502 for peak voltage on Voltmeter.
Disconnect the Voltmeter.

Retune L503 and L504 for maximum output power.

Readjust C301, C307, C311, and C313 for maximum power.

Adjust R560 until a decrease in power is noticed. This step must be performed in order to activate the reverse power protection circuit.

Unkey transmitter.

Modulation Adjustment:

1. Select a channel with no tone. If all channels have tone, turn R561 to the maximum counterclockwise position.
2. Increase the Audio Generator's output to 4-volts rms.
3. Key the transmitter.
4. Adjust R516 for the proper modulation deviation as follows:

Models A, B, or C with CTCSS adjust for +4.0 kHz.

Models A, B, or C without CTCSS adjust for +4.5 kHz.

Models UK with CTCSS adjust for +2.0 kHz.

Models UK without CTCSS adjust for +2.1 kHz.

5. Decrease audio output of Audio Generator to zero.
6. If the radio has CTCSS tone, select a tone channel and adjust R561 for proper tone deviation. For Models A, B, or C adjust for +750 Hz deviation; for UK Model adjust for +300 Hz tone deviation.
7. Unkey transmitter.

Carrier Frequency Adjustment:

1. Keying transmitter adjust C545 for the correct carrier frequency within ±100 Hz.

NOTE: Insure that transmitter is not keyed before proceeding.

Receiver Alignment

Equipment Required:

1. Signal Generator with frequency calibrated within ± 100 Hz
2. Frequency Counter (not needed if transmitter carrier frequency set procedure has been done)
3. DC Voltmeter
4. AC Voltmeter with dB scale
5. SINAD Distortion Meter (may not be used depending on type of RF alignment method used)
6. 10 MHz Bandwidth Scope (may not be used depending on type of IF alignment method used)

Pre-Alignment Procedure:

1. Set L401, L402, L403, L404, and L406 so that the core is flush with top of the coil form.
2. With no signal to the radio and power on, adjust L409 for 4.5 VDC ± 0.25 V at Pin 10 of IC405 (referenced to chassis ground).
3. If the VCO has not yet been adjusted (L201) then perform Steps 2 through 4 listed under "Pre-Alignment Procedure" in Transmitter Alignment part of Section 2-2.
4. If the transmitter carrier frequency adjustment has not been done (reference paragraph 1 of the "Carrier Frequency Adjustment" instruction), the receiver local oscillator frequency must be adjusted. Do this by connecting the Frequency Counter's probe through a 27pF capacitor to the tap of L406. The frequency measured will be the carrier frequency minus 10.7 MHz. If not, adjust C545 for the correct frequency. NOTE: FINAL adjustment of C545 must be made in accordance with paragraph 1 of the "Carrier Frequency Adjustment" instructions.
5. Put the radio in the MONITOR mode.

Local Oscillator Adjustment:

1. Connect a DC Voltmeter between M2 and ground.
2. Tune L405 for a dip in the Voltmeter reading.
3. Connect the Voltmeter between M3 and ground.

4. Tune L406 for peak voltage on the Voltmeter.
5. Retune L405 and L406 for a peak reading on the Voltmeter.

RF Circuit Adjustment:

1. Method 1 - Quieting Method

- a. Connect an AC Voltmeter across the speaker terminals. Unsquench the radio and adjust the noise volume to a comfortable listening level. Note this reference level on the AC dB scale.
- b. Connect an unmodulated RF Signal Generator to the antenna connector and set the Generator to the receiver frequency.
- c. Increase the RF output of the Generator until the noise level drops 15 dB as read on the Voltmeter.
- d. Tune L401, L402, L403, and L404 for minimum noise. While tuning, decrease the Generator's RF output to maintain the noise level between the 20 and 15 dB quieting points.
- e. Repeat Step d. until maximum quieting is obtained. A 20 dB quieting sensitivity of 0.5 μ V or less should be measured. If not, then go on to "IF Adjustment," Method 1. If the quieting measurement is correct, then go to "Discriminator Adjustment."

2. Method 2 -SINAD Distortion Method

- a. Connect the SINAD Distortion Meter across the speaker terminals. Unsquench the radio and adjust the volume to a comfortable listening level.
- b. Connect a modulated Signal Generator, that has been set to the correct receive frequency, to the antenna connector. Modulate the Generator with a 1 kHz tone at the following deviations: for the RH250A, B, or C = ± 3.0 kHz; RH250UK = ± 1.5 kHz.
- c. Increase the Generator's RF output until a 6 dB SINAD is measured.
- d. Adjust L401, L402, L403, and L404 for maximum SINAD ratio.

- e. Decrease Generator's output to maintain 6 dB SINAD and repeat Step d. until no improvement in SINAD can be made.
- f. Measure 12 dB SINAD signal level. This level should be less than 0.35 μ V (-116 dBm). If it is not, go on to IF Alignment Method 2. If satisfactory, go on to Discriminator Adjustment.

IF Adjustment:

1. Method 1 - RF Level Method

- a. Connect a scope between M4 and ground.
- b. Connect an unmodulated Signal Generator to the antenna connector.
- c. Increase the Generator's output for a 100 mV peak-to-peak reading on the Oscilloscope. The RF level should be approximately 20 μ V (-81 dBm).
- d. Adjust L407 for greatest peak-to-peak voltage on the scope.

2. Method 2 - SINAD Distortion Method

- a. Connect a SINAD Distortion Meter across the speaker terminals.
- b. Connect a Signal Generator, modulated as given in paragraph 2.b. under "RF Circuit Adjustment."
- c. Adjust the Generator's RF output for a 6 dB SINAD reading on the meter.
- d. Adjust L407 for the best SINAD.

Discriminator Adjustment:

1. Connect an AC Voltmeter across the speaker terminals.
2. Connect a Signal Generator, modulated per paragraph 2.b. under "RF Circuit Adjustment," to the antenna connector. Adjust the RF output level to 1 mV (-47 dBm).
3. Adjust L409 for maximum AC voltage on the meter.

Before installing the unit, perform the following checks. Select and test each channel for:

1. Proper receiver sensitivity (0.35 uV SINAD max)
2. Proper transmitter power output (25 W min)
3. Correct transmitter carrier frequency (+100 Hz)
4. Correct modulation deviation limiting point

+4 kHz peak - A,B,C models with a CTCSS channel

+4.5 kHz peak - A,B,C models without CTCSS

+2.0 kHz peak - UK model with a CTCSS channel

+2.5 kHz peak - UK model without CTCSS

5. Correct CTCSS tone modulation (if applicable)

Between 500 Hz and 1 kHz peak - A,B,C models

Between 250 Hz and 500 Hz peak - UK model

6. Proper CTCSS decoder operation (if applicable)
7. Correct CTCSS encoding frequency (if applicable)
8. Correct VCO voltage in RX and TX modes (between 4 - 7.5 VDC)

Select all the functions on the keypad to be sure they are operable. For example: place the radio in the scan mode and make sure it can lock-up on a busy channel. Check the Priority Function and Priority Scan mode for proper operation. Be sure all the LEDs are lighting correctly.

After installation, test the unit on an active channel, testing out any encoder options, for example, to see if the system responds correctly. Start and run the vehicle to be sure there is no interference with the radio's performance.

2-4. CIRCUIT DESCRIPTIONS

Receiver (refer to Figure 4 - Block Diagram)

The received signal passes through a solid state T/R switch on the PA Board and then to the RF amplifier, Q409, on the Main Board. The output of the RF amp is coupled to the gate circuit of the mixer stage, Q410. The signal of the first local oscillator (LO) is fed to the source input of the mixer transistor, Q410. The first LO's frequency is 10.7 MHz below the received signal's carrier frequency.

The resultant 10.7 MHz signal from the mixer is filtered by a 4-pole crystal filter. The filtered 10.7 MHz signal is fed to the IF integrated circuit. The IF chip contains the second LO and second mixer. The second LO's frequency is 10.245 MHz. By mixing the 10.7 MHz frequency and the second LO frequency, the second IF is obtained, 455 kHz, which is filtered by a ceramic filter, CF401. The filtered 455 kHz is passed through limiting amplifiers and then coupled to a quadrature detector. The quadrature detector (on IC405 along with L409) converts the frequency modulated signal to an amplitude modulated (voltage) signal. The audio output is Pin 10 of IC405.

The audio output from the quadrature detector, Pin 10, is applied to the de-emphasis circuit, R221 and C226, and to the input of the low-pass tone filter, IC202 (C and B). The low-pass tone filter amplifies the tone and filters out the audio voice signals. The output of the tone filter is fed into a Schmitt trigger, Q204 and Q205, which shapes the tones into the correct digital waveforms for the microprocessor (uP) to decode the tones. If the correct tone is decoded, the uP will turn the MSC LED on and un-mute the receive audio path. After the de-emphasis circuit, the receive voice audio passes through a high-pass filter, IC202 (D and A). The high-pass filter reduces the amplitude of the tone signal to an acceptable level in the receive audio path with a minimal affect on the overall receive audio.

The input to the squelch circuit is restricted to high frequency audio, approximately 6 to 25 kHz, by the use of R and C components. The "noise" occurring in this range is amplified by IC405 and detected by CR410. The DC voltage resulting from the detected "noise" is applied to IC405, Pin 14 which drives Pin 16 low and activates the squelch switch circuit, Q411, Q412, and Q413. When the "noise" is of sufficient amplitude, the audio is turned off and the receiver is muted. When a signal appears, the "noise" is reduced to a point where the detected signal is no longer sufficient to mute the audio.

If the channel being received is one that is programmed for a CTCSS tone, the microphone is on hook and the monitor switch is not in the MON position; even though the noise is reduced by a received signal on the correct RF carrier frequency, if the uP, IC403, does not decode the correct tone from the Schmitt trigger circuit, the uP will then activate the squelch switch circuit and the audio will remain muted. If the correct tone is decoded, the squelch switch circuit will not mute the audio. The audio is turned "ON" and the audio amplifier, IC406, is allowed to operate normally and deliver audio to the speaker.

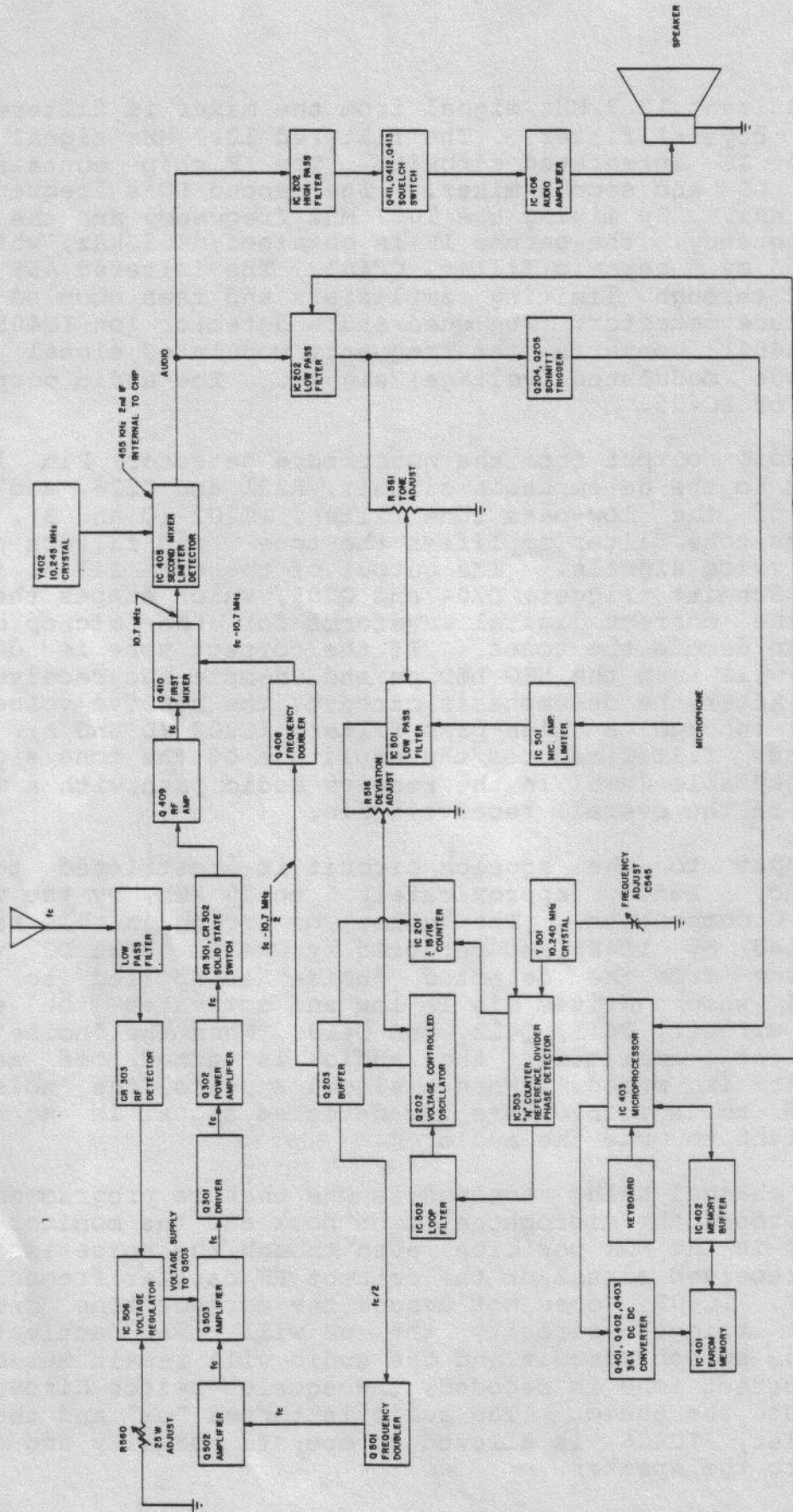

FIGURE 4 - BLOCK DIAGRAM

Audio speech is converted from air pressure variations to an electrical signal by the microphone which also pre-emphasizes the audio signal by 6 dB per octave. This signal is then applied to two operational amplifiers, IC501A and IC501D. The Modulation Limiter is the second operational amplifier, IC501A. There is sufficient gain in the first and second operational amplifier so when a signal is applied which is 20 dB greater than that required for a 3 kHz deviation, the second operational amplifier will go into rail-to-rail limiting; i.e., $V_{CC} - 0.7$ V and 0 V.

After the audio signal is limited, it passes through a four-pole active low-pass filter. This active filter consists of the third and fourth operational amplifiers of IC501 (B and C) and its associated resistors and capacitors. The resultant signal is then limited with respect to sideband splatter and has an 18 dB per octave roll-off above 3 kHz.

The CTCSS tones are applied after the audio limiter but before the TX audio low-pass filter. The tones are generated by the uP and their harmonics are filtered by the low-pass filter, IC202 (B and C). R561 is used for the adjustment of the tone modulation signal.

The output of the modulation amplifier/post limiter filter circuit, Pin 8 of IC501, is fed to a master deviation control (R516). This control is set by running the modulation amplifier into full limiting and adjusting R516 for maximum system deviation.

The audio is then applied to a varactor frequency modulator. The varactor, CR201, is series-coupled through C202 and C204 to the voltage controlled oscillator, VCO. By varying the voltage on the varactor diode at an audio rate, the resonant frequency of the VCO is varied which results in the oscillator output being frequency modulated at the audio frequency. The capacitance change versus voltage, of the varactor, is almost linear which results in low distortion. The frequency doubling stage, Q501, increases both the VCO frequency and the deviation to the desired value.

The input to Q501 is one half (1/2) the carrier frequency and after passing through Q501, the signal is "rich" in harmonics of the input frequency. L501 and L502 are tuned for the carrier frequency and have attenuation to the fundamental and other harmonics. The signal is then amplified by Q502 and further attenuation to the fundamental and harmonics is achieved by L503 and L504.

The amplifier, Q503, the driver, Q301, and the power amplifier, Q302, stages are used to amplify the carrier signal to the required output power. Impedance matching to 50 ohms is provided by L307, C310, C311, C312, and C313. The stages in this section operate in the Class C mode.

During transmit, saturated switch Q510 is turned on supplying biasing current for CR301 and CR302. When CR302 is biased "on," a short to ground is provided at this point. Through phase rotation, C316, L309, and C315 present a high impedance to the RF path at CR301. This high impedance prevents the RF power from going to the receiver. Also, when CR301 is turned "on," this presents a low impedance to the RF power, thereby allowing the RF power to be coupled into the low-pass filter.

Harmonic suppression, which reduces the harmonics of the carrier below the level that is required by the FCC, is provided by the output low-pass filter. This filter is composed of L310, L311, L312, L313, C317, C318, and C319. The cutoff frequency is approximately 210 MHz.

The RF output power is sampled by R304 and R305 and rectified by CR303. This rectified voltage is filtered by C321 and the resultant D.C. is applied to the inverting input, Pin 4, of the variable voltage regulator, IC506. By varying R560, the voltage at Pin 4 can be varied which, when compared to the voltage at Pin 5, varies the output voltage at Pin 10, which is the supply voltage for Q503. R560 is adjusted so that the output power is 25 watts. For whatever reason, if the output power goes higher or lower than 25 watts, the voltage regulator compensates and adjusts the voltage on Q503 to maintain a 25 watt output.

Control Board

The digital displays, DS101 and DS102, on the control board are seven-segment yellow LED channel displays. These displays are controlled by circuitry on the main board. Binary-coded decimal information is sent to the decoder/driver, IC404, from the uP for DS102. IC404 then drives DS102 to show the correct decoded number. DS101 is controlled by Q407, which is activated by the uP.

The TX, SCAN, MSG, and PRIORITY LEDs are controlled by Q101, Q102, Q103, and Q104, respectively. These transistors are used as NPN saturated switches which are activated directly by the uP. Q101 is controlled by the TX 9.5 V supply; Q102, Q103, and Q104 are controlled by the microprocessor, IC403.

The MON switch, SW101, is a SPDT switch used to disable the tone decoding when on a tone channel and to reset the MSG LED. The DAY-NIGHT switch, SW102, is a DPDT switch used to control the brightness of the display and the illumination of the keyboard. In the DAY position, the displays are driven by 5 V and the keyboard is not lit. In the NIGHT position, the displays are driven by 2.9 V because three diodes are added in series with the 5 V line to the displays. Also, in the NIGHT position, the keyboard is illuminated by an incandescent light bulb in conjunction with a light-bar.

The volume control, R101, takes the audio from the squelch switch circuit and controls the voltage level going to the audio amplifier, IC406. The squelch control, R102, controls the amplitude of noise signal supplied to the input of the squelch noise amplifier, Pin 12 of IC405.

Synthesizer

The synthesizer consists of a voltage-controlled oscillator (VCO), reference oscillator, "N" and "A" dividers, phase detector, and a low-pass loop filter. The digital information for the synthesizer to be at one half (1/2) the correct frequency for the receiver or the transmitter comes from the uP. The synthesizer integrated circuit, IC503, contains the reference oscillator "N" divider, phase detector, out-of-lock detector, and receive/transmit switches.

The VCO consists of Q202, L201, C202, C204, C205, C218, C208, C210, CR201, and CR202. The frequency of the oscillator is determined by the voltage across CR202. This frequency is divided by either 15 or 16 by IC201. The resultant frequency is then divided by a programmable "N," contained in IC503, which results in a frequency close to 2500 Hz, 6.25 kHz in the "UK" model.

The reference oscillator consists of Y501, IC503, C543, C544, and C545, which is used for fine frequency adjustment. The oscillator is a parallel resonant Colpitts type. The reference oscillator has a heater-controlled crystal, Y501. This crystal is specified to ensure that the frequency stability between -5°C and $+65^{\circ}\text{C}$ is within $\pm 0.0005\%$. The heater resistor, R545, begins to heat up at approximately $+10^{\circ}\text{C}$ and is well activated at 0°C . This ensures $\pm 0.0005\%$ frequency stability over the temperature range of -30°C to $+60^{\circ}\text{C}$ for both the receiver and transmitter. C543, C544, and C545 are NPO ceramic capacitors, thereby adding additional stability to the oscillator. The reference oscillator frequency of 10.240 MHz is divided by 4,096 and the resultant frequency is 2500 Hz for the "A, B, and C" models. The reference divider in the "UK" model takes a 12.8 MHz reference oscillator frequency and divides by 2,048 to get the 6.25 kHz reference frequency.

The reference signal is compared to the signal out of the $\div N$ counter (internally) and an error signal is generated at Pin 4 of IC503.

The error voltage from the phase detector is then amplified and filtered by IC502 and becomes the control voltage for the VCO. This voltage is applied to CR202 and changes the VCO frequency in a direction that reduces the phase differences between reference oscillator frequency and the VCO frequency. When the loop is "LOCKED," the frequency of the VCO is proportional to the frequency of the input signal from the reference oscillator.

Microprocessor and EAROM

The microprocessor, IC403, acts as a central controller. It monitors inputs such as the keyboard, the EAROM, PTT line, monitor switch, hookswitch, programming jumper, squelch, and CTCSS tone input. It controls the display and status LEDs, information placed in the EAROM, receiver squelch operation, the beep for keyboard contact closure, synthesizer frequency, CTCSS tone frequency, and transmitter/modulation enable line.

Starting with the keyboard, which is a 4 x 4 crosspoint matrix, the column contacts are connected to Pins 3, 4, 5, and 6 of IC403 and the row contacts are connected to Pins 19, 18, 17, and 16 of IC403. Whenever the radio is idle, the column lines are low (less than 0.8 VDC) and the row lines are high (greater than 2 VDC). When a contact is closed, the microprocessor senses a change on one of the row lines and investigates further to determine which column closure caused the row line to go low. The voltages on the schematic are when the keyboard is idle.

The display and status LEDs are controlled by the microprocessor. DS101 displays a one (1) when Q407 is turned on. When Channel 10 is selected, the base voltage will be 0.7 V. DS102 is driven by a BCD to seven-segment decoder, IC404. The display segments are defined in Figure 5.

	BCD CODE				
	Display	D	C	B	A
	0	0	0	0	0
	1	0	0	0	1
	2	0	0	1	0
	3	0	0	1	1
	4	0	1	0	0
	5	0	1	0	1
	6	0	1	1	0
	7	0	1	1	1
	8	1	0	0	0
	9	1	0	0	1

FIGURE 5

The inputs to IC404 are four (4) BCD (binary-coded decimal) lines (A,B,C, and D) from the microprocessor, IC403. A zero is displayed when the BCD lines are all low (less than 0.8 V) as shown in the table of Figure 5. For a zero, the a,b,c,d,e, and f segments are turned on by pulling Pins 1, 13,10,8,7, and 2 low, respectively. The microprocessor also controls the PRIORITY, MSG, and SCAN LEDs through Q104, Q103, and Q102, respectively. Turning on the transistors causes the LEDs to turn on.

CTCSS tones are both encoded from and decoded by the microprocessor. The encoded tone is derived from the signals at Pins 30, 31, and 32 of IC403. These are summed and filtered on the VCO/Filter Board. The CTCSS tone signal received after filtering and shaping on the VCO/Filter Board is interrogated by the microprocessor at Pin 38. The microprocessor, if programmed for CTCSS, will interrogate the signal on the line provided a carrier is present. Carrier detection is accomplished by momentarily looking at the squelch control line (the line is being used as an input in this case), to determine whether the radio is squelched or not. The squelch circuit must be operative, i.e. the squelch control must be adjusted so that without a carrier present there is no noise from the speaker. The reason this is done is to eliminate false decodes on noise. When a signal is received and the correct tone is present, the microprocessor releases the squelch control line (Pin 28 of IC403 now acting as an output). The microprocessor will also release the squelch control line when Pins 14 or 23 go high; this occurs when the microphone goes off-hook or the monitor switch is in the MON position.

The CTCSS tone frequency is determined by counting circuitry in the microprocessor. The time base reference for these tones comes from the timing oscillator of the microprocessor. The oscillator's frequency is 3.579545 MHz. This oscillator serves as the clock for the microprocessor and is essential for its operation.

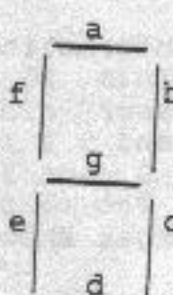
The microprocessor programs and reviews information stored in the EAROM through a buffer, IC402. This IC translates voltage levels between 5 V (microprocessor side) to 15 V (EAROM side). The inputs, driven by 0 and 5 V levels, are Pins 2,5,7,9,11, and 14. The outputs, 0 and 15 V level drivers, are Pins 3,4,6,10,12, and 15. The voltages on the schematic are static, that is, the voltages shown are when the EAROM is idle.

When the EAROM is accessed (for a read or write operation), the high voltage supply is activated (by the microprocessor). The collector of Q403 pulses low to activate the high voltage supply. During this time, there is a +15 V level at Pin 1 and a -21 V level at Pin 2 of IC401. The status LEDs also flicker during an EAROM access.

The receiver and transmitter frequency codes are controlled by the microprocessor. The microprocessor takes the stored information from the EAROM and serially transmits it to the synthesizer chip, IC503 (SYNTH DATA, SYNTH CLOCK lines). The synthesizer clock path (SYNTH CLOCK) is the line connecting Pin 8 of IC403 to Pin 9 of IC503. The synthesizer data path (SYNTH DATA) is the line connecting Pin 9 of IC403 to Pin 10 of IC503. Both lines are normally low when in an idle state. During data transfer the clock line alternates between +5 V and 0 V, around a frequency of 12.8 kHz, clocking the data into IC503. When the radio is turned on, the microprocessor is reset by the delay in voltage rise on Pin 39 caused by C470. A low on this line restarts the microprocessor and the radio will "set-up" on the priority channel.

The WH2516 has a different reset circuit than the RH250. Instead of C470 resetting the microprocessor, a transistor, Q405, does. When the radio is turned on, Q405 holds Pin 39 of IC403 low. When the voltage on the 13 V switched lines reaches 8 V, Q404 is biased on, thereby turning off Q405. This series of events holds Pin 39 of IC403 low while the 5 V supply stabilizes. Anytime the 13 V line fluctuates below 8 V, the microprocessor will be reset. This allows the microprocessor to be held in reset before the 5 V supply becomes unregulated. The WH2516 reset schematic is shown in Figure 6.

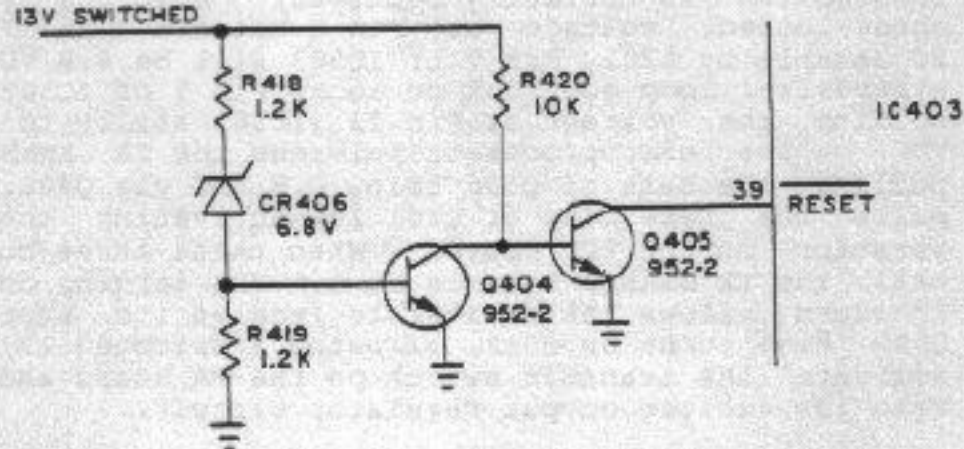

FIGURE 6 - RESET CIRCUIT WH2516

36 V Supply and Control Switching

The μP controls when the 36 V DC to DC converter is activated. To test if the 36 V power supply is operating correctly, ground the collector of Q403 to turn on the DC to DC converter. The main components of the 36 V supply are T401, Q401, Q402, CR401, CR402, CR403, R401, R402, R403, R404, C401, C402, and C403. When activated, there is approximately +15 V on the cathode of the 36 V Zener diode, CR403, and -21 V on the anode of CR403 (voltages are relative to chassis ground).

The radio's main power, 13 V at J3, is regulated into two supplies. The digital circuits associated with the microprocessor and synthesizer derive power from the 5 V supply (regulated by IC504). The circuits which derive power from the 9.5 V supply are as follows: the receiver's RF, IF and audio circuits; the transmitter's modulation and exciter circuits; and the VCO oscillator, buffer, and loop filter circuits.

The receiver circuits receive a switched 9.5 V voltage which is controlled by Q508, Q507, and the synthesizer chip (IC503, Pin 12). In the receive mode the base of Q507 is around 0.7 V. Q507 saturates, turning on Q508. The transmitter's exciter circuits also have a switched 9.5 V voltage. This voltage is controlled by Q505, Q509, Q506, the synthesizer chip (IC503, Pin 13), Q406, and the microprocessor (IC403, Pin 27). Q509 is turned on only if three conditions are met. First, the transmitter frequency data transferred to the synthesizer IC must be received correctly; second, the phase-lock loop must be "LOCKED"; third, the microprocessor must release the ENABLE line. The synthesizer chip releases

The TX ENABLE line at Pin 13 of IC503 if the TX frequency information is correctly received. When the synthesizer is phase-locked, voltage at Pin 6 between 4 and 7.5 VDC and adjustable by L201, Pin 7 of IC503 will be 4.9 VDC. When the synthesizer loop goes out of lock, Pin 7 of IC503 pulses low, holding the voltage at Pin 13 (IC503 still) to around 0.8 VDC. The microprocessor releases the TX ENABLE line by pulling the base of Q506 below 0.5 VDC via Q406. Q406 also pulls the base line of Q201 low activating the modulation varactor on the VCO Board. When these three conditions are met, the TX ENABLE line is at 1.6 VDC turning on Q509; this in turn allows the exciter to receive its supply voltage. Q509 also turns on Q510, allowing a switched 13.8 V line to activate the transmit switch on the PA Board and supplies 13 V to the exciter output regulator circuit.

2-5 TROUBLESHOOTING

The troubleshooting flowcharts on the following pages are designed to aid in localizing the problem area. Once the problem area is localized, use voltage measurement data, visual inspections of components in the area, and other troubleshooting practices to find the defective component. The voltages shown on the schematics are all referenced to ground. They were made with a voltmeter having a 10 megohm input impedance.

PROBLEM 1 - RECEIVER COMPLETELY DEAD, NO NOISE AT SPEAKER

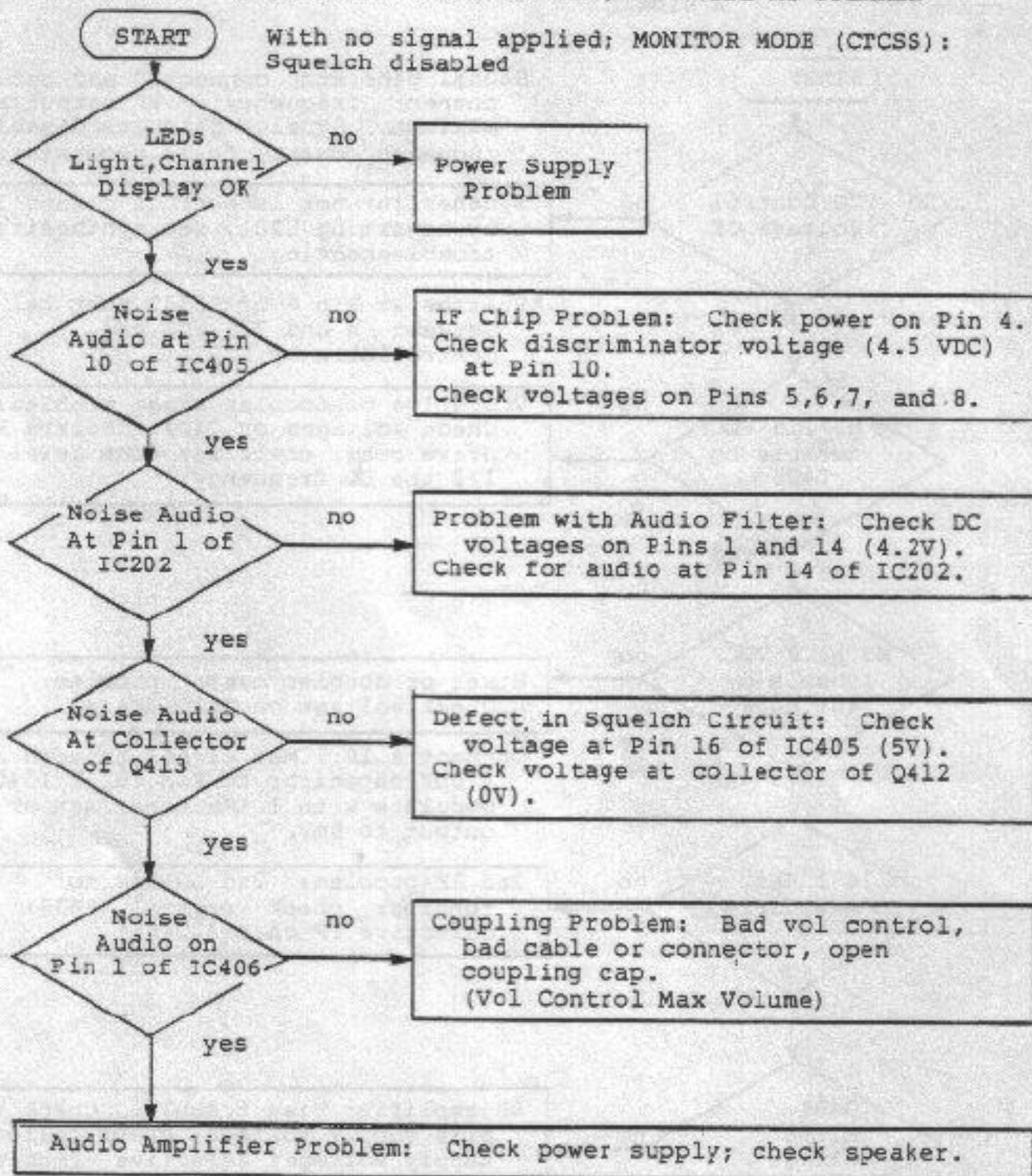

PROBLEM 2 - RECEIVER NOISE PRESENT BUT WILL NOT RECEIVE
A SIGNAL

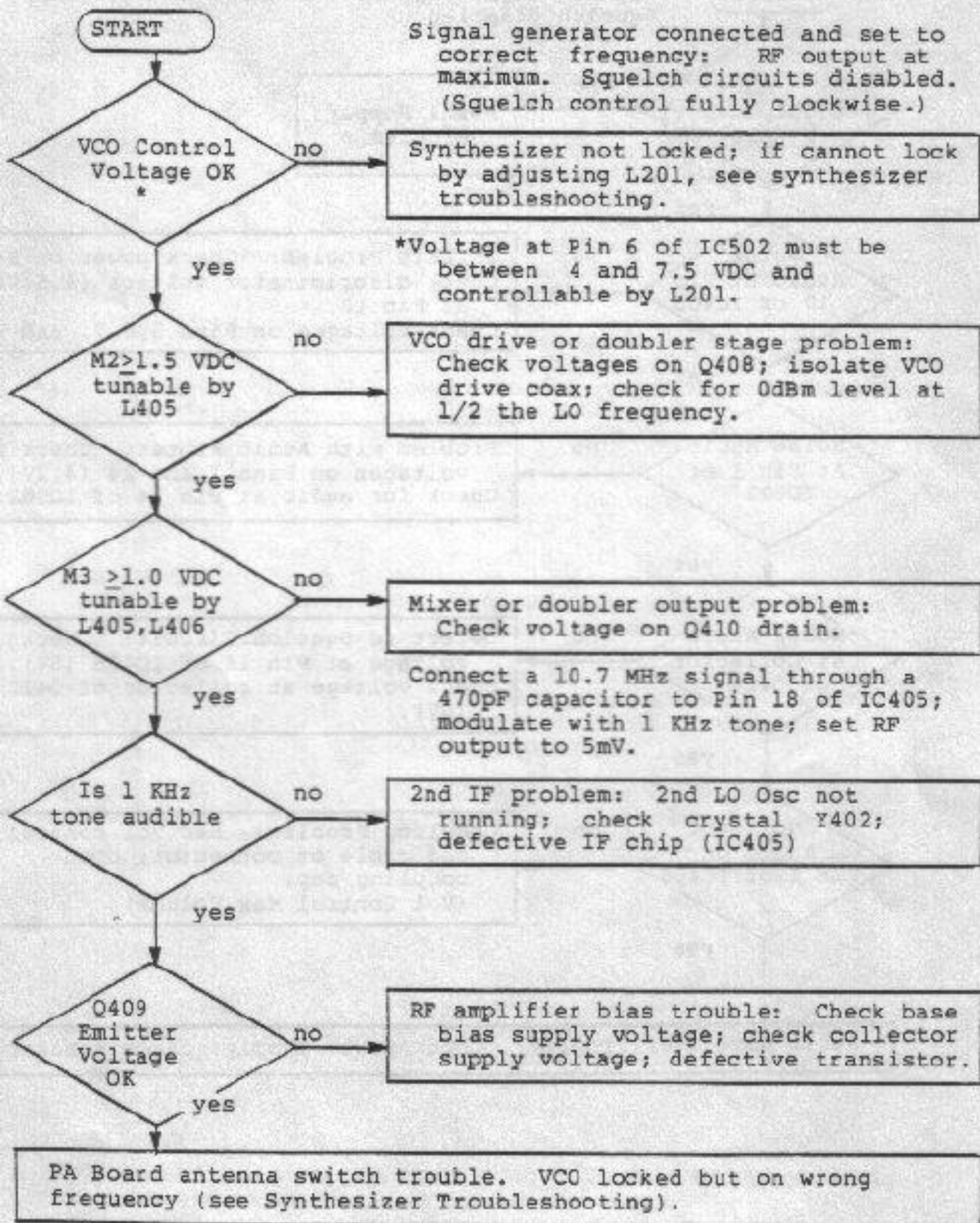

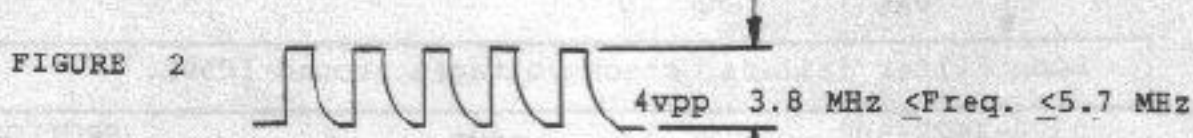
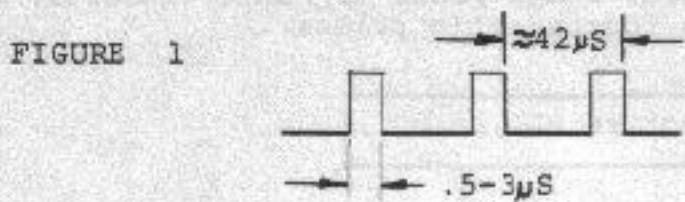
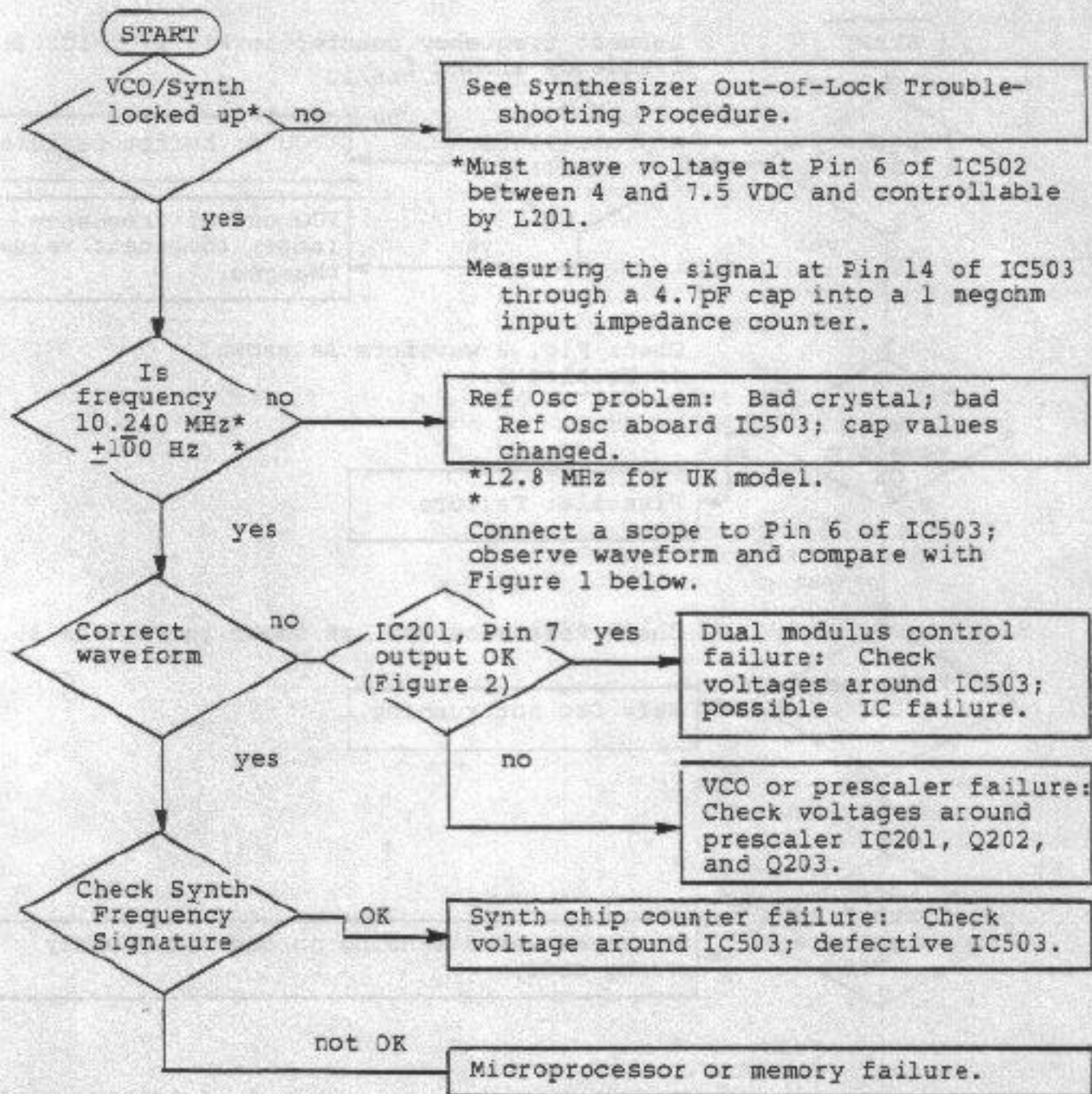

PROBLEM 4 - SYNTHESIZER LOOP WILL NOT LOCK

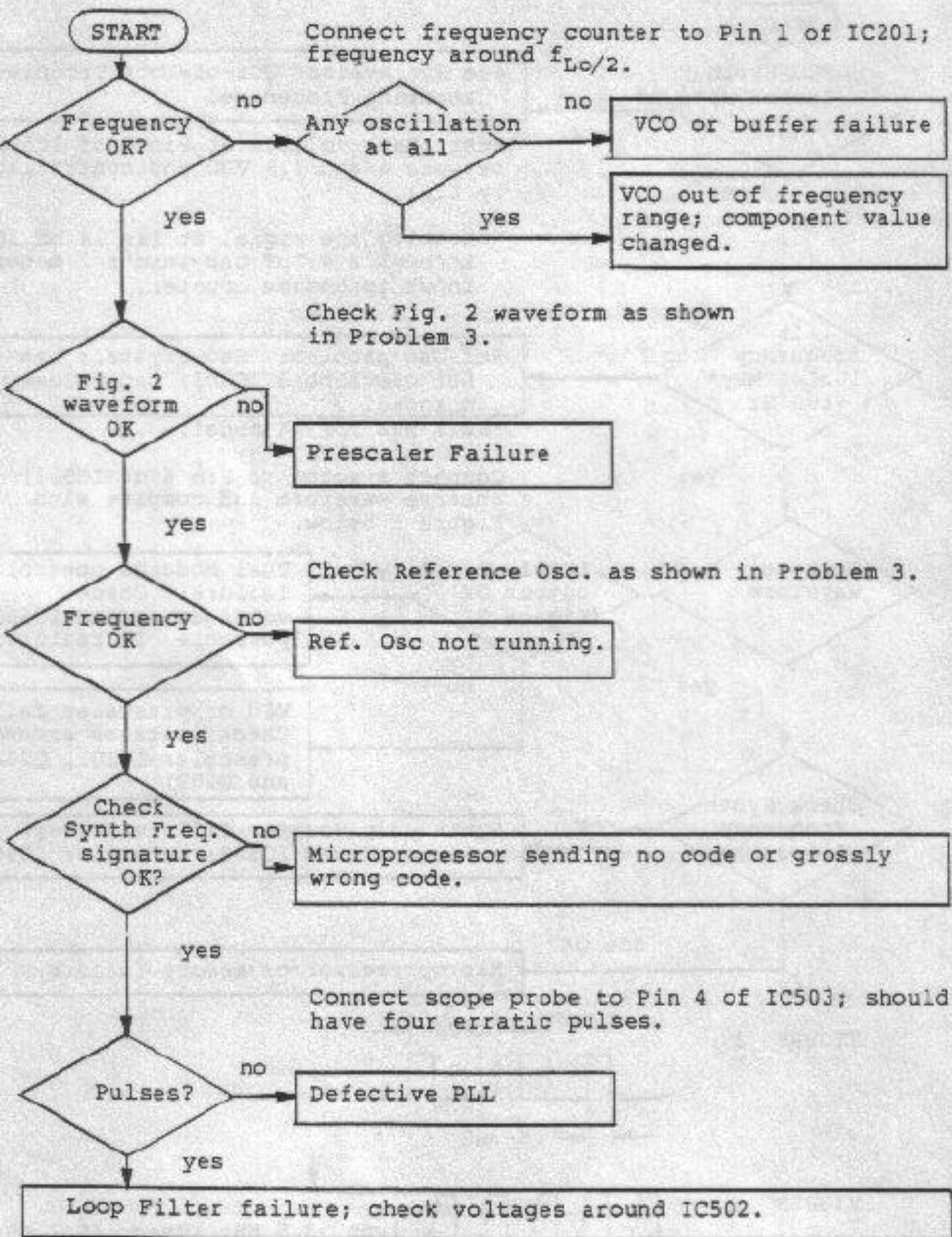

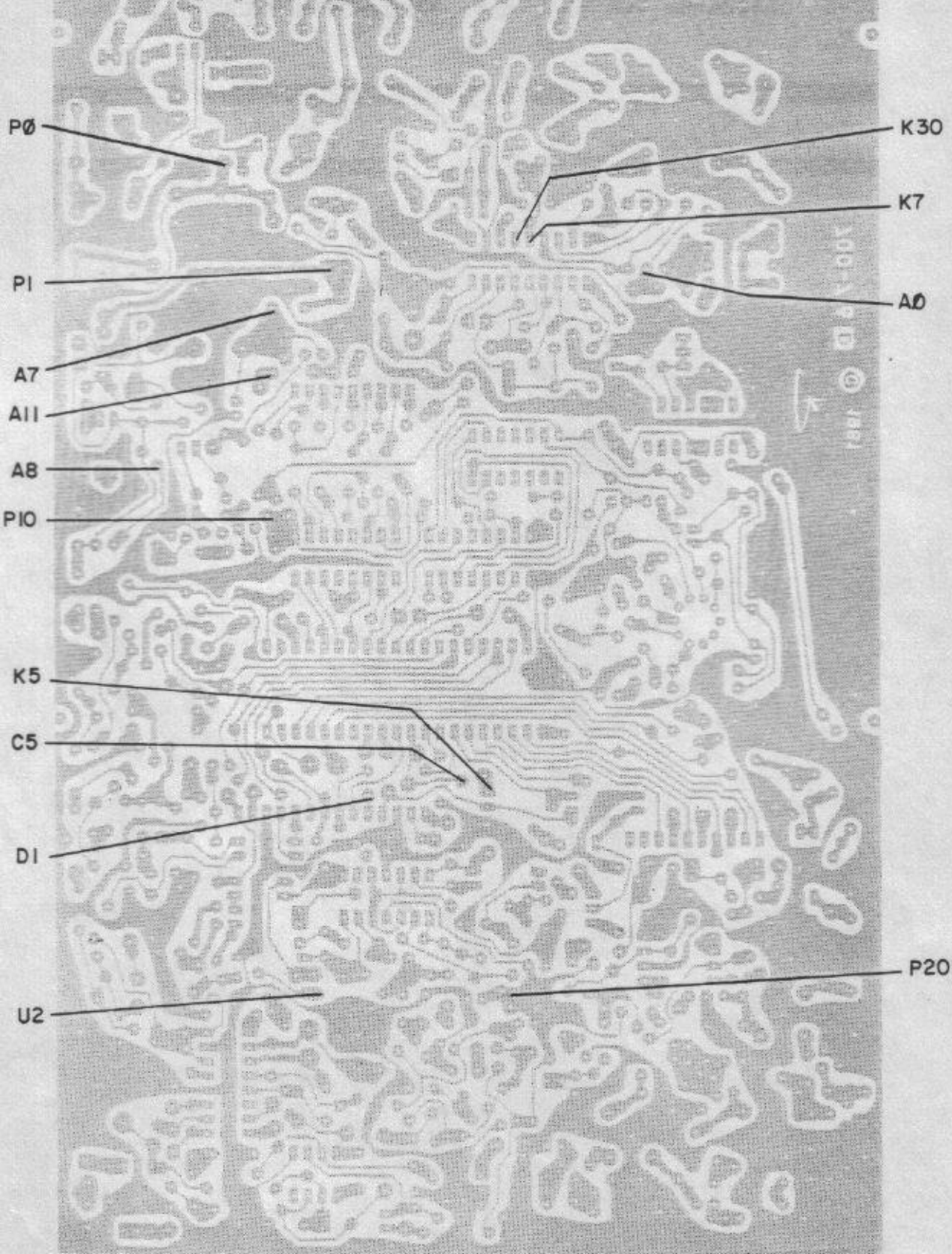

CIRCUIT TIE POINTS

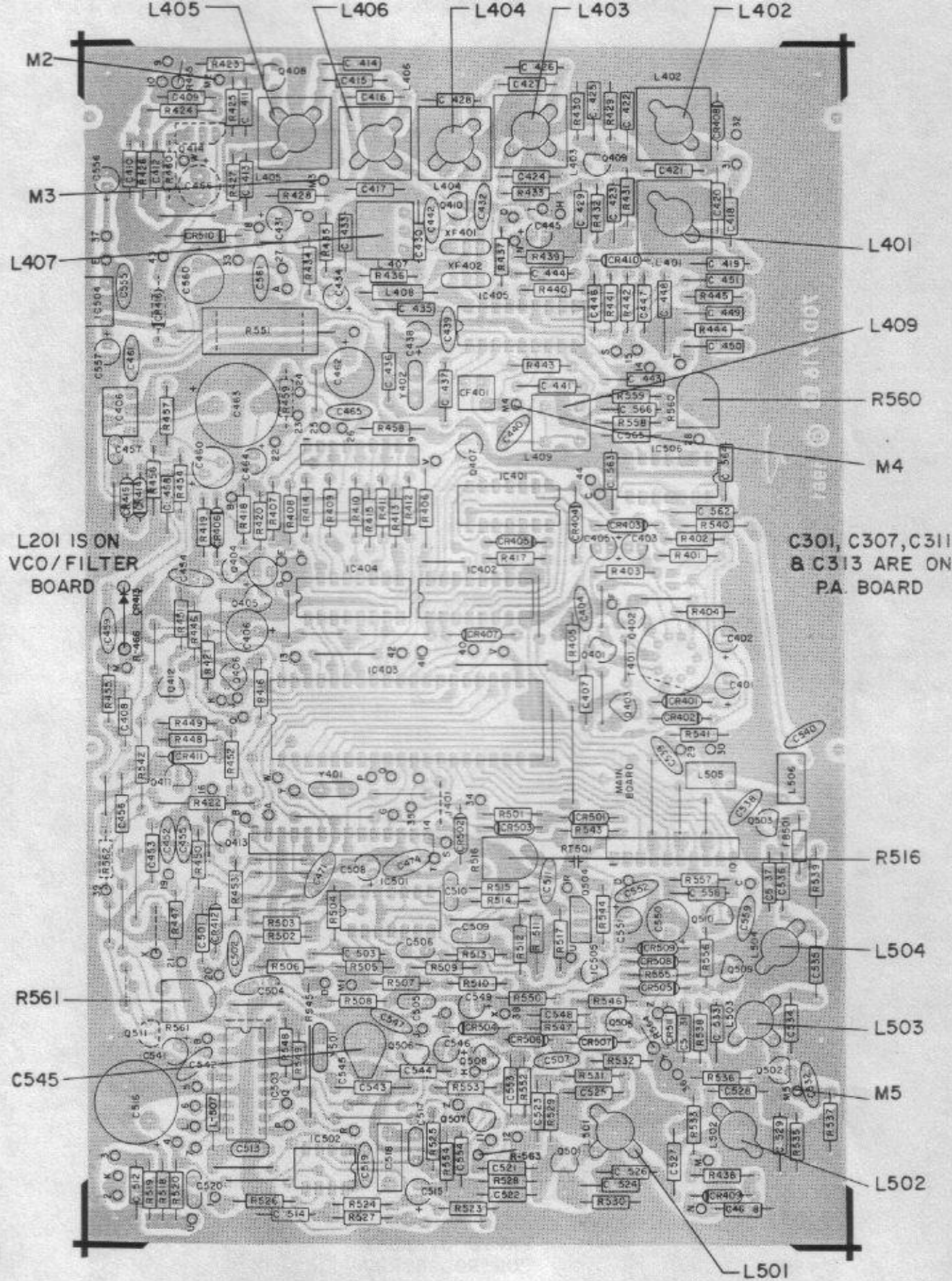

L201 IS ON
VCO/FILTER
BOARD

C301, C307, C311
& C313 ARE ON
P.A. BOARD

TUNING POINTS

CONTROL BOARD
700-687

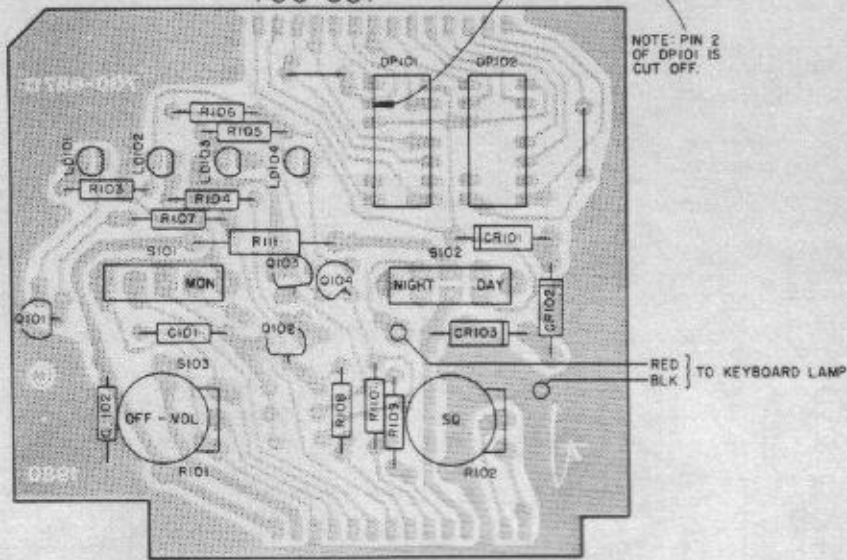

PARTS PLACEMENT
CONTROL BOARD

CONTROL BOARD
700-687

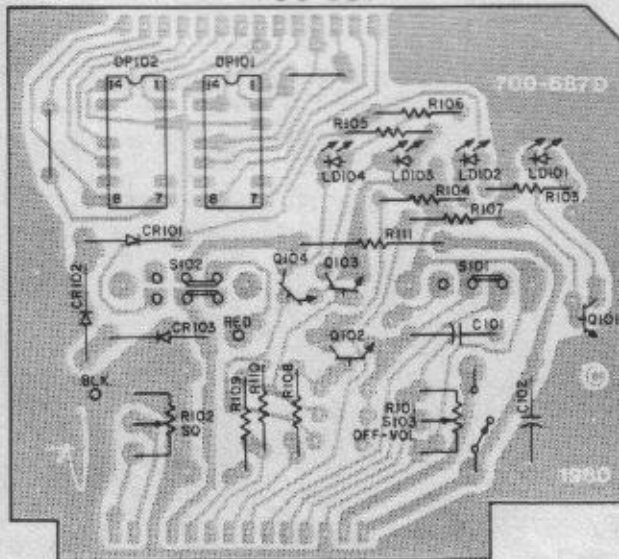

PARTS OVERLAY
CONTROL BOARD

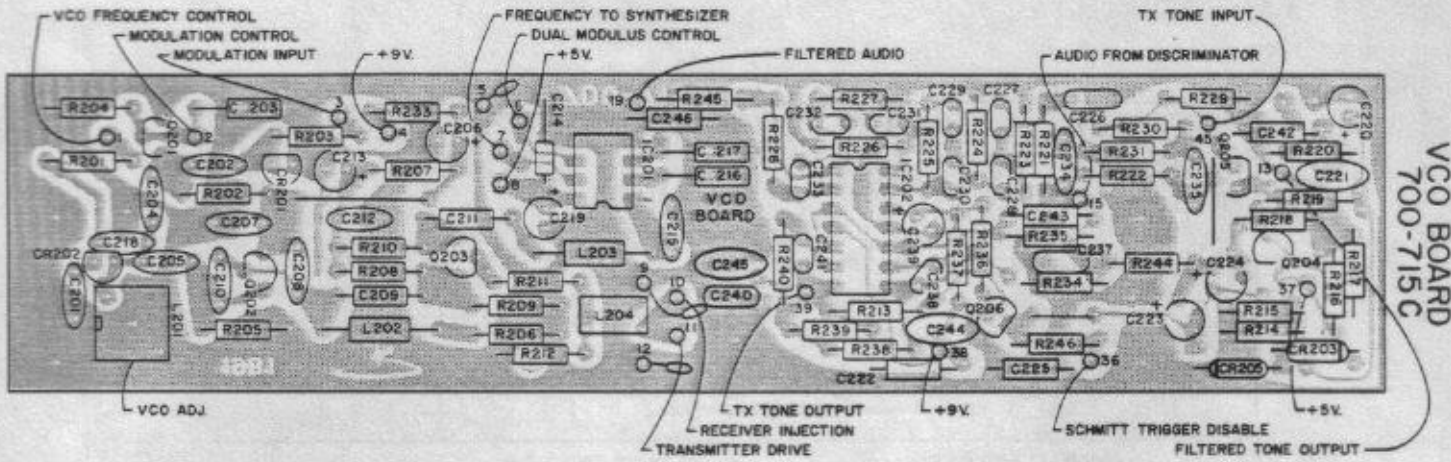

PARTS PLACEMENT
VCO BOARD

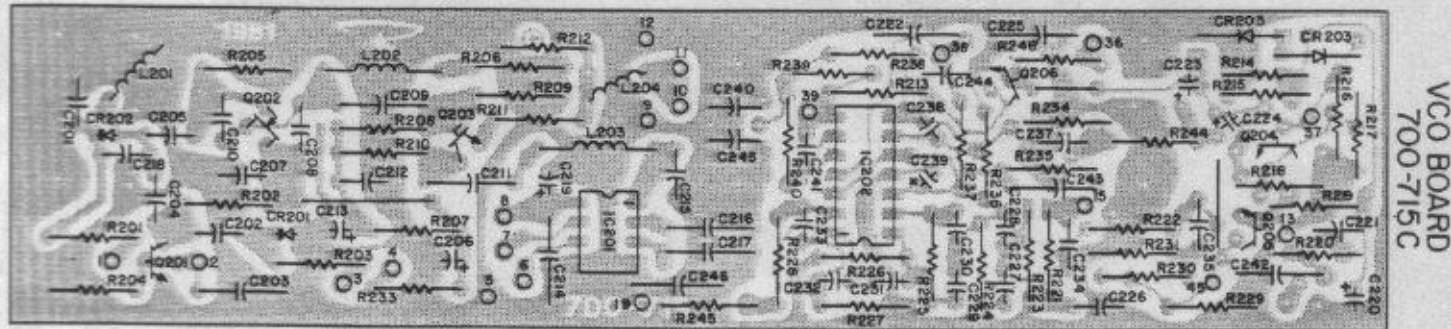

PARTS OVERLAY
VCO BOARD

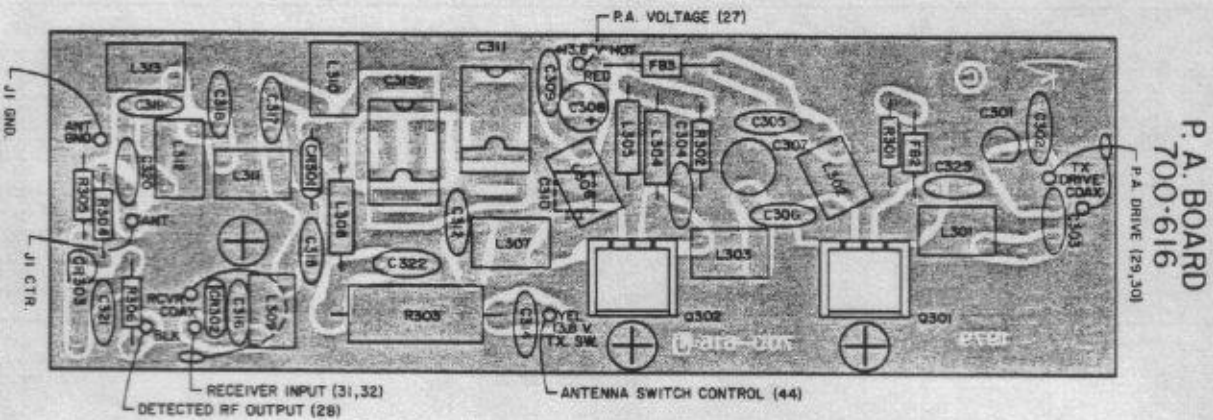

**PARTS PLACEMENT
P.A. BOARD**

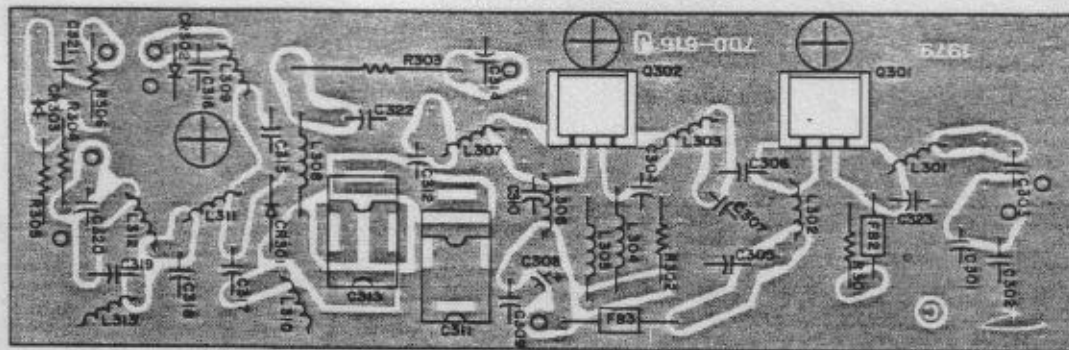

**PARTS OVERLAY
P.A. BOARD**

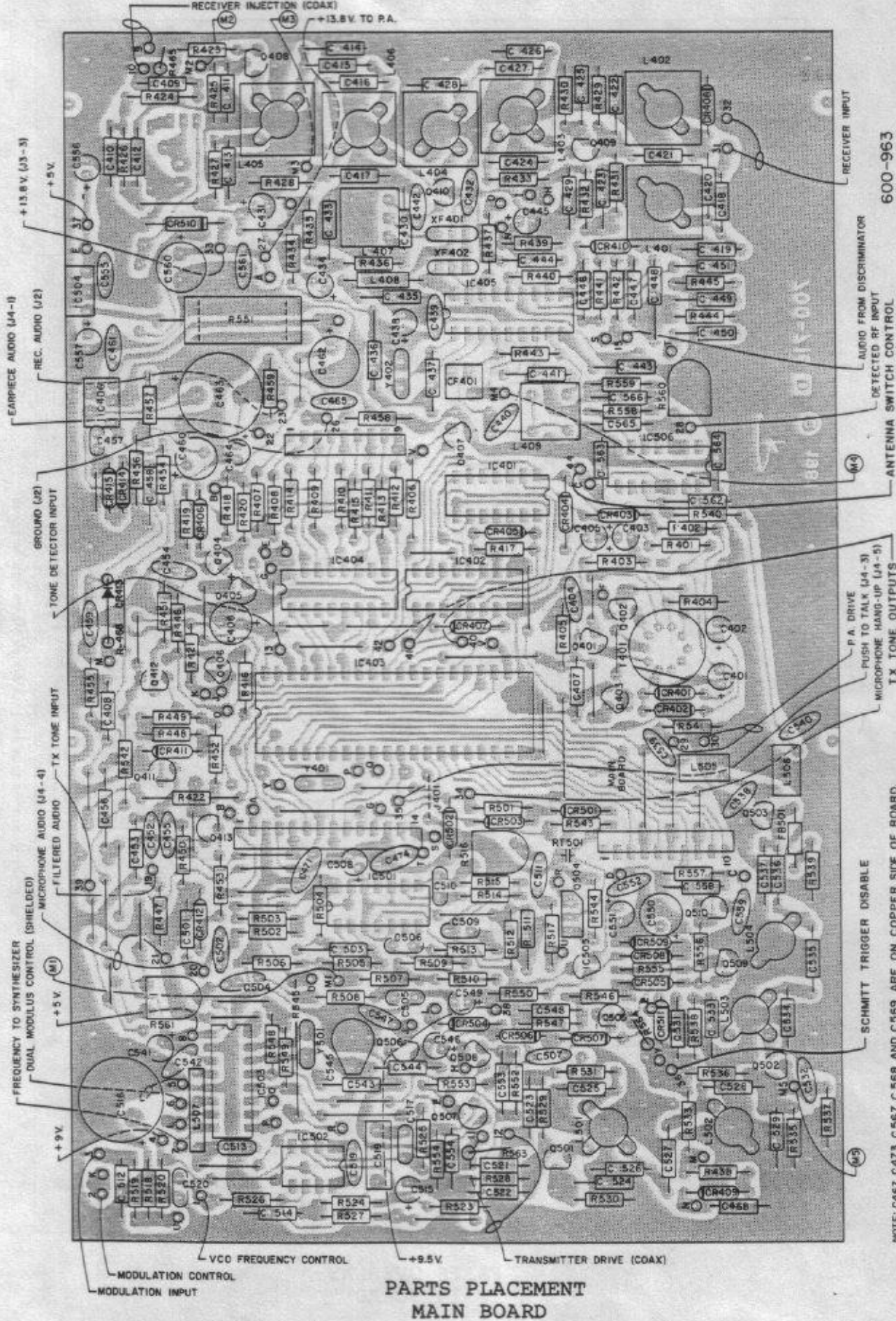

+13.8V (U3-3)
+5V

GROUND (J2)

TX TONE INPUT

MICROPHONE AUDIO (U4-4)
(SHIELDED)

+9V

MODULATION INPUT

EARPHONE AUDIO (U4-1)

REC. AUDIO (J2)

TONE DETECTOR INPUT

MODULATION CONTROL

VCO FREQUENCY CONTROL

MODULATION CONTROL

RECEIVER INJECTION (COAX)

+13.8V TO PA

RECEPTION INPUT

AUDIO FROM DISCRIMINATOR

DETECTED RF INPUT

ANTENNA SWITCH CONTROL

P.A. DRIVE

PUSH TO TALK (U4-3)

MICROPHONE HAND-UP (U4-5)

TONE OUTPUTS

SCHMITT TRIGGER DISABLE

TRANSMITTER DRIVE (COAX)

MAIN BOARD

0

NOTE: C467, C473, C566, AND C569 ARE ON COPPER SIDE OF BOARD.

PARTS PLACEMENT
MAIN BOARD

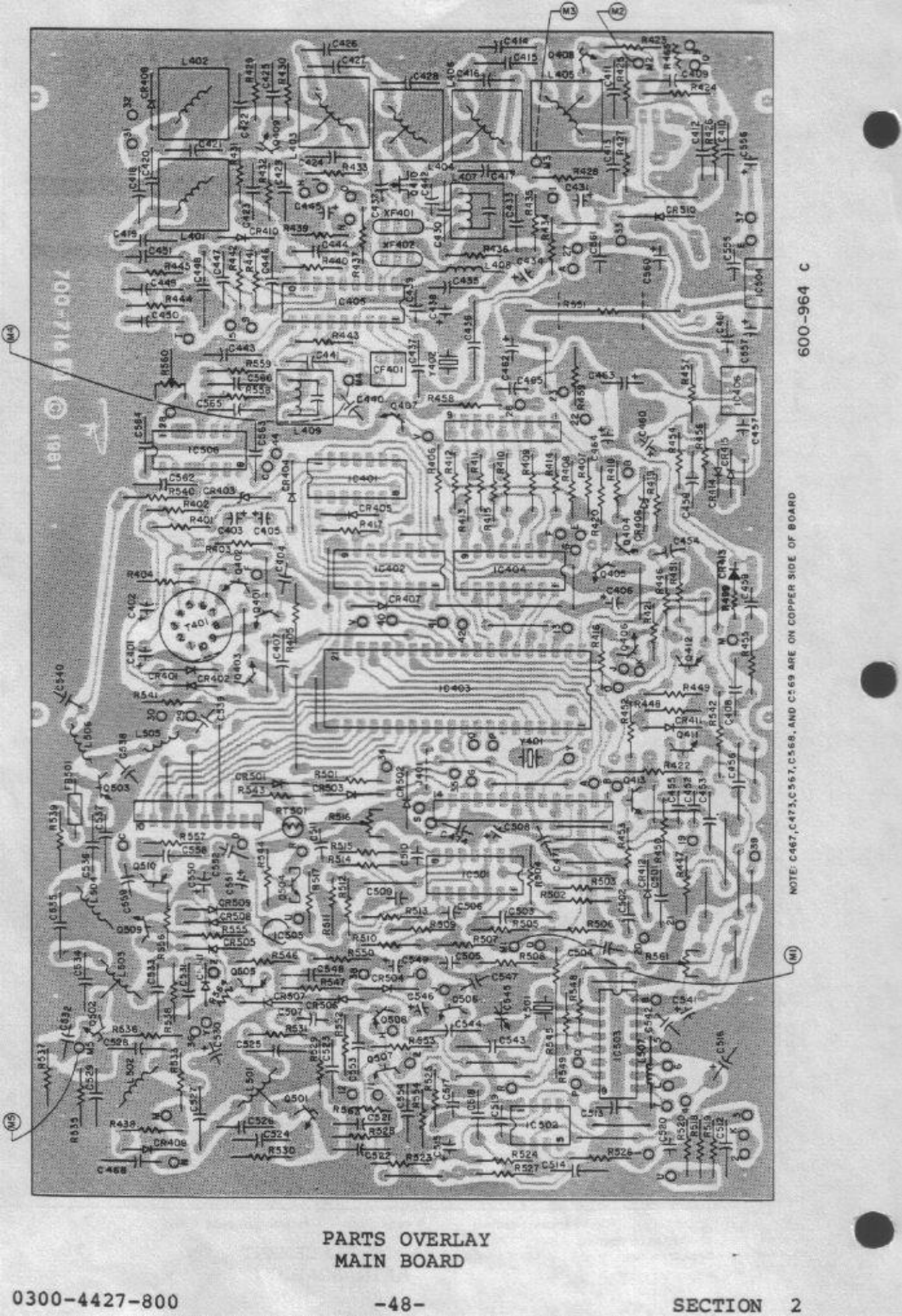

1981 0917-007

600-964 C

NOTE: C467, C473, C567, C568, AND C569 ARE ON COPPER SIDE OF BOARD.

PARTS OVERLAY
MAIN BOARD

700-716 D © 1981

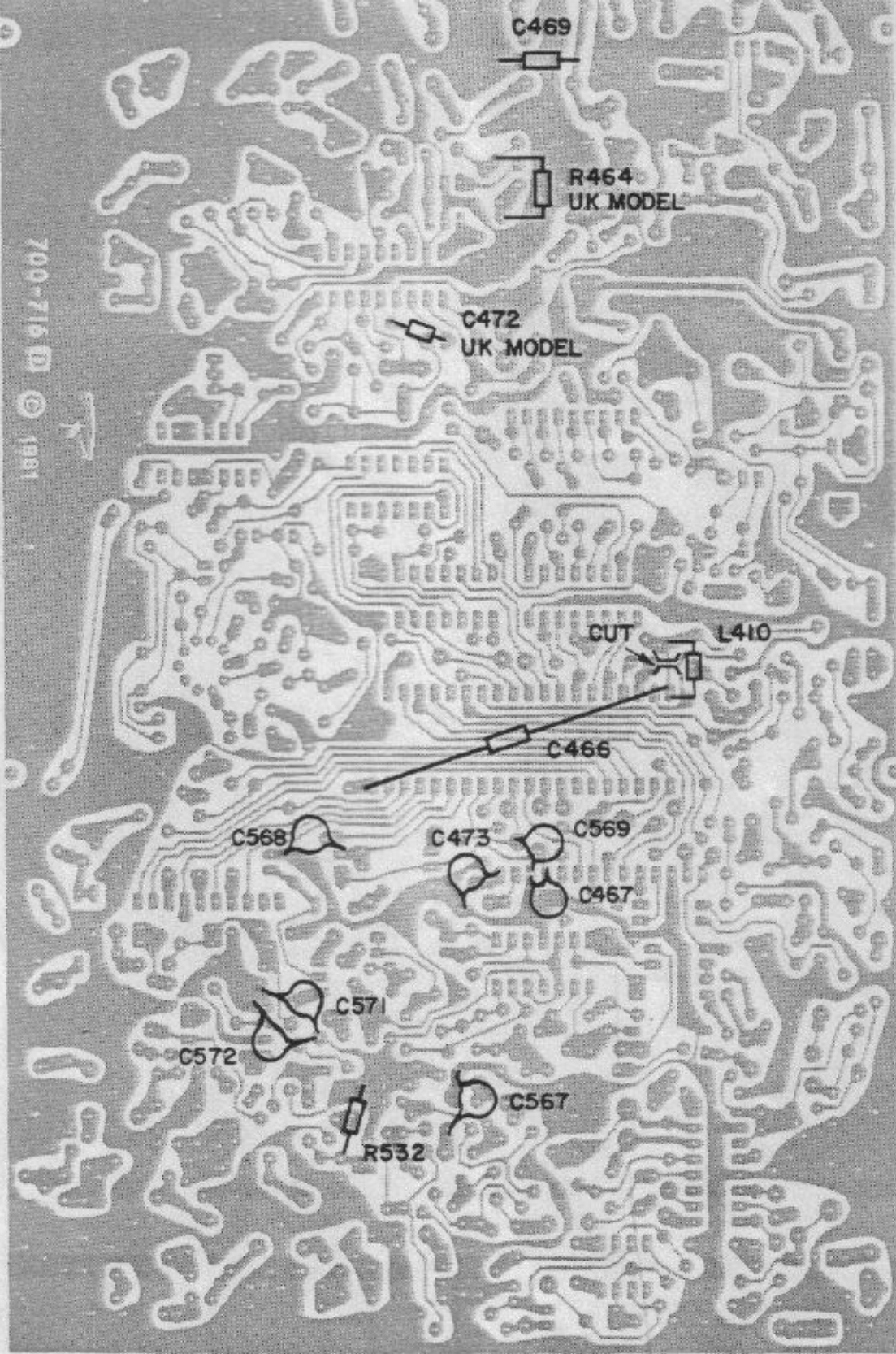

PARTS PLACEMENT
BOTTOM SIDE

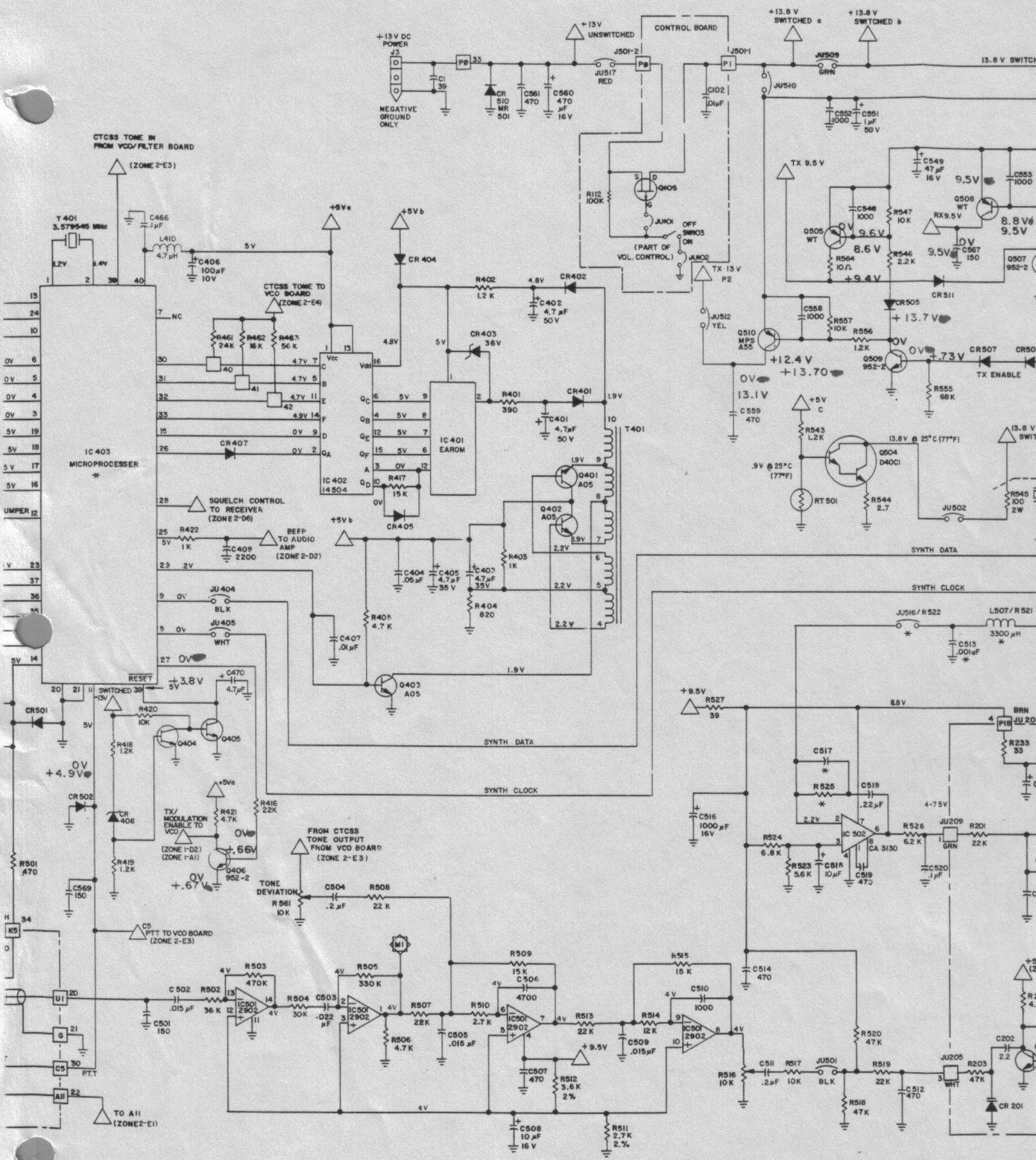

RED PRINT INDICATES TRANSMIT
BLUE PRINT INDICATES RECEIVE

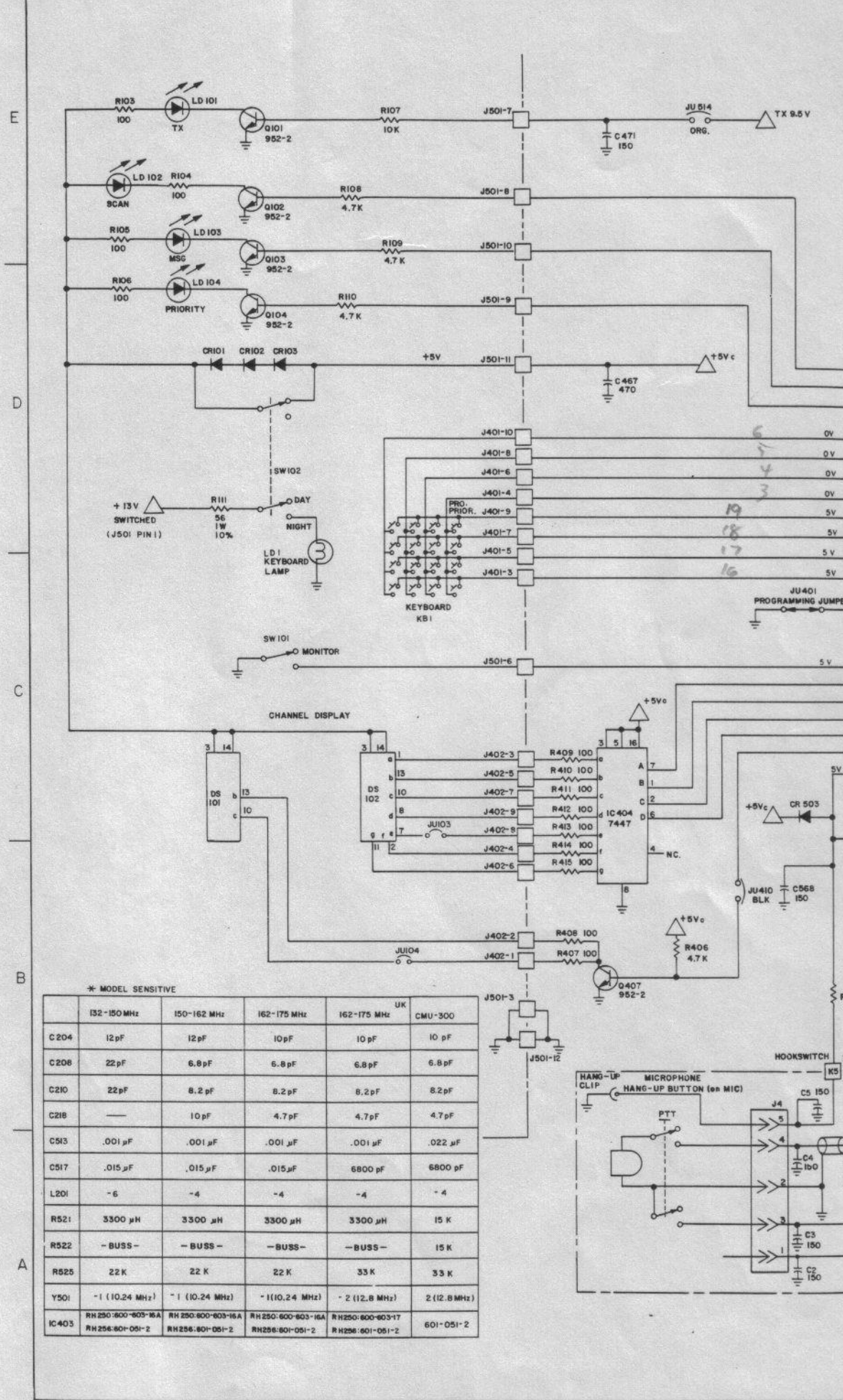

E
D
C
B
A

* MODEL SENSITIVE

	132-150 MHz	150-162 MHz	162-175 MHz	162-175 MHz UK	CMU-300
C204	12 pF	12 pF	10 pF	10 pF	10 pF
C208	22 pF	6.8 pF	6.8 pF	6.8 pF	6.8 pF
C210	22 pF	8.2 pF	8.2 pF	8.2 pF	8.2 pF
C218	—	10 pF	4.7 pF	4.7 pF	4.7 pF
C513	.001 μF	.001 μF	.001 μF	.001 μF	.022 μF
C517	.015 μF	.015 μF	.015 μF	6800 pF	6800 pF
L201	-6	-4	-4	-4	-4
R521	3300 μH	3300 μH	3300 μH	3300 μH	15 K
R522	- BUSS -	- BUSS -	- BUSS -	- BUSS -	15 K
R525	22 K	22 K	22 K	33 K	33 K
Y501	-1 (10.24 MHz)	-1 (10.24 MHz)	-1 (10.24 MHz)	-2 (12.8 MHz)	2 (12.8 MHz)
IC403	RH 250-600-603-16A RH 256-601-051-2	RH 250-600-603-16A RH 256-601-051-2	RH 250-600-603-16A RH 256-601-051-2	RH 250-600-603-17 RH 256-601-051-2	601-051-2

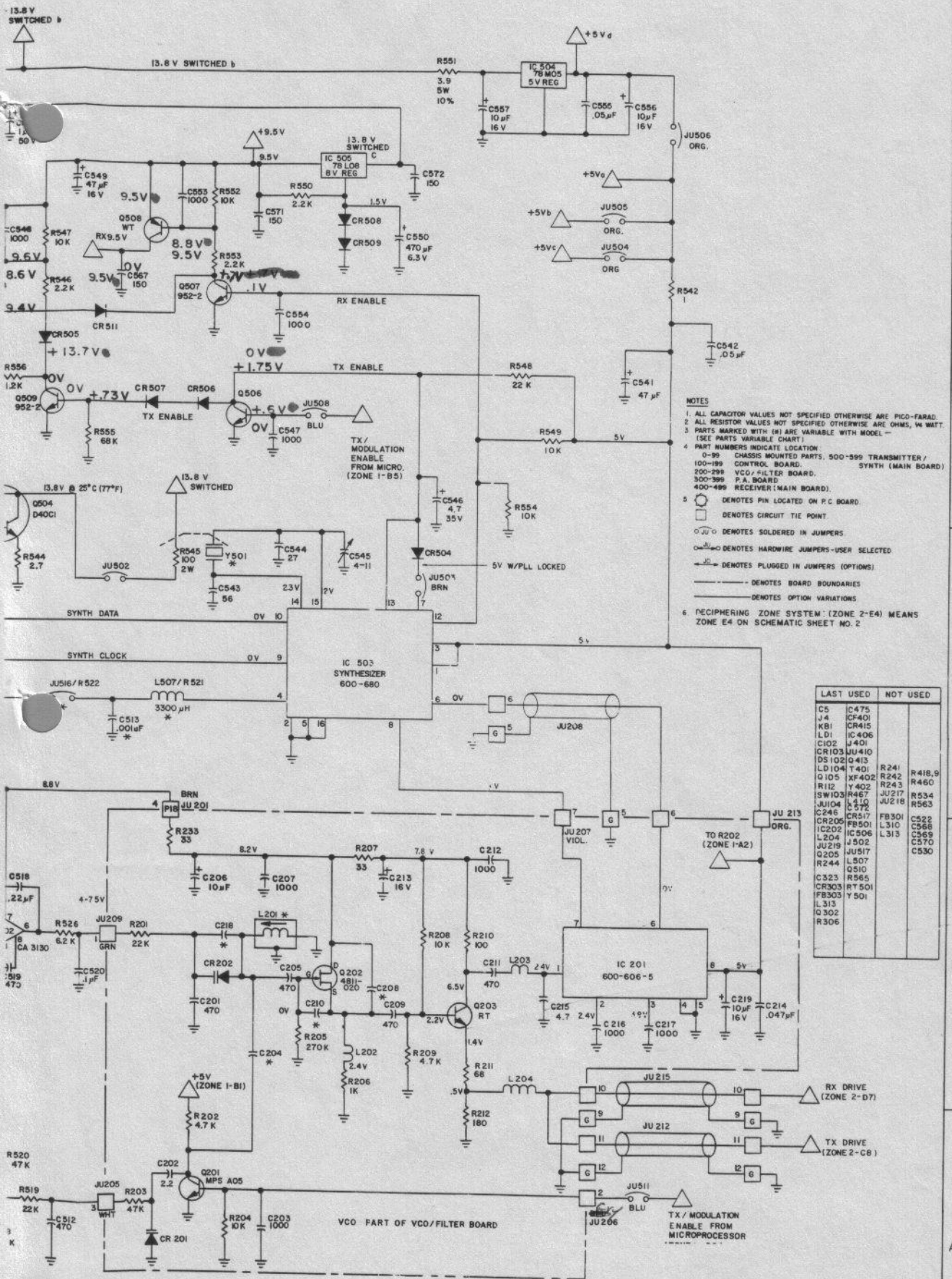

- NOTES**
1. ALL CAPACITOR VALUES NOT SPECIFIED OTHERWISE ARE PICO-FARAD.
 2. ALL RESISTOR VALUES NOT SPECIFIED OTHERWISE ARE OHMS, 1/4 WATT.
 3. PARTS MARKED WITH (M) ARE VARIABLE WITH MODEL - (SEE PARTS VARIABLE CHART).
 4. PART NUMBERS INDICATE LOCATION:
 0-99 CHASSIS MOUNTED PARTS, 500-599 TRANSMITTER / 100-199 CONTROL BOARD, 200-299 VCO / FILTER BOARD, 300-399 P.A. BOARD, 400-499 RECEIVER (MAIN BOARD), SYNTH (MAIN BOARD)
 5. DENOTES PIN LOCATED ON P.C. BOARD.
 DENOTES CIRCUIT TIE POINT.
 DENOTES SOLDERED IN JUMPSERS
 DENOTES HARDWARE JUMPSERS - USER SELECTED
 DENOTES PLUGGED IN JUMPSERS (OPTIONS)
 DENOTES BOARD BOUNDARIES
 DENOTES OPTION VARIATIONS
 6. RECIPHERING ZONE SYSTEM (ZONE 2-E4) MEANS ZONE E4 ON SCHEMATIC SHEET NO. 2

LAST USED		NOT USED	
C5	IC475		
J4	CR401		
KB1	CR415		
L31	IC406		
C102	L401		
CR103	JU410		
DS102	Q413		
LD104	T401	R241	R418,9
Q105	XF402	R242	R460
R112	Y402	R243	
SW103	R467	JU217	
L204	J502	JU218	
JU104	L410		
CR245	CR517	FB301	C522
CR205	FB501	L310	C568
IC202	IC506	L313	C569
L204	J502		C570
JU219	J502		C530
Q205	JU517		
R244	L507		
Q201	Q510		
CR323	R565		
CR303	RT501		
FB303	Y501		
L313			
Q302			
R306			

PRINT INDICATES TRANSMIT VOLTAGE
 PRINT INDICATES RECEIVE VOLTAGE

SCHEMATIC - 704-155Y
SHEET 1

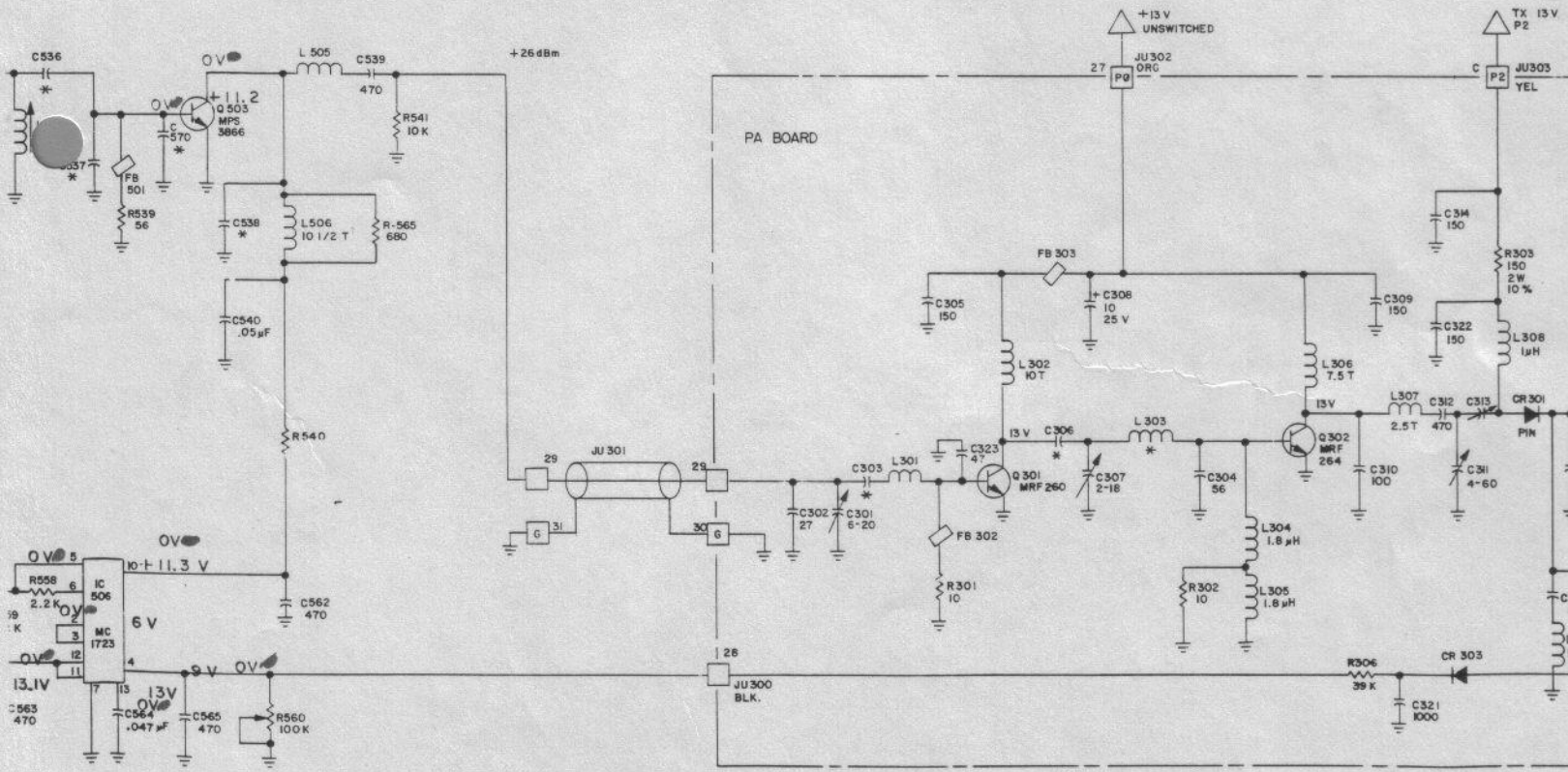
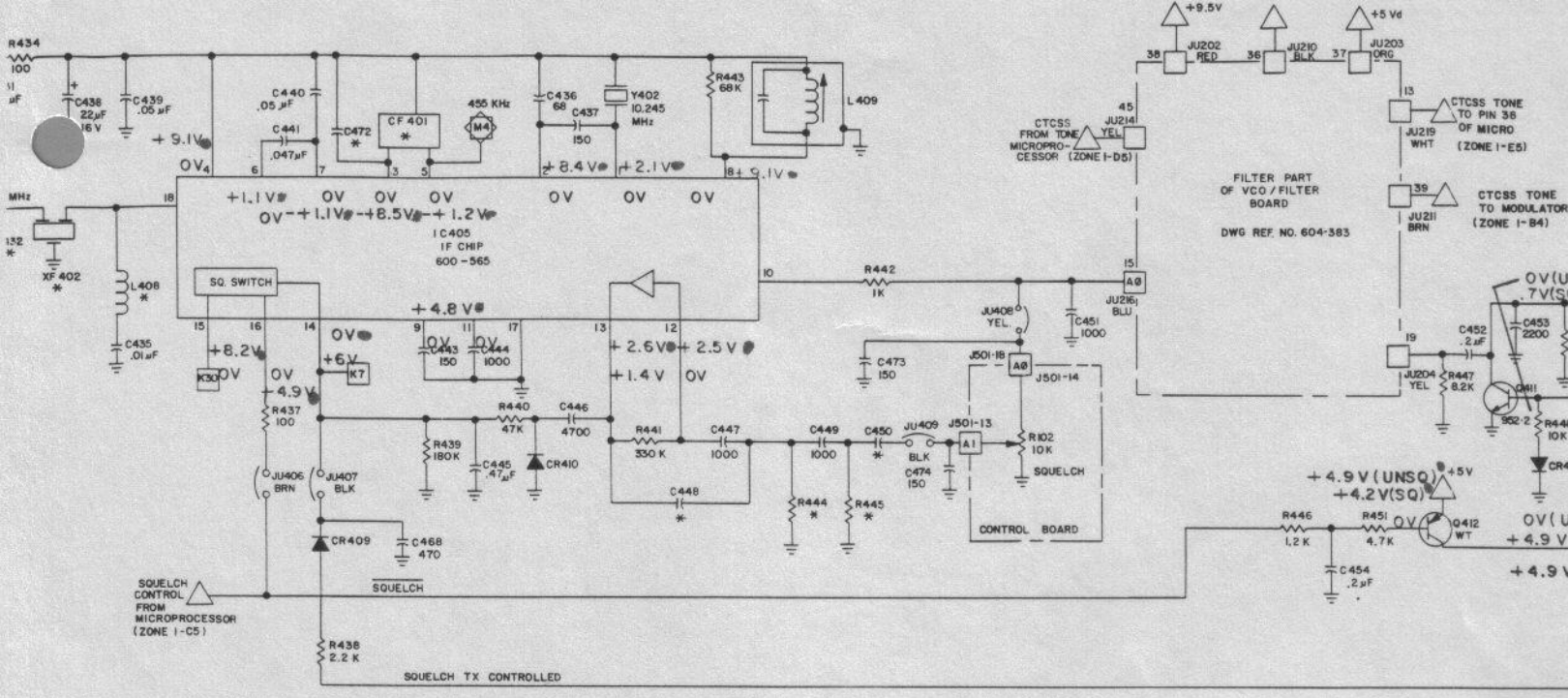

* MODEL SENSITIVE (- MEANS OMIT PART; JU MEANS REPLACE WITH JUMPER)

	C306	C303	C414	C415	C416	C419	C421	C426	C427	C428	C432	C472	R467	C526	C528	C529	C534	C536	C537	C570	L303	L401	L402	L504		R464	CF 401	XF 401	XF 402	
134-150 MHz	18pF	150pF	8.2 pF	47 pF	10pF	6.8pF	10pF	8.2pF	.39pF	8.2pF	3.9pF	—	680Ω	4.7pF	10pF	4.7pF	10pF	8.2pF	27pF	—	3.5T(-6)	-20	-20	-20		—	302-095	302-322		
150-175 MHz	18pF	82pF	6.8pF	47 pF	8.2pF	5.6pF	8.2pF	6.8pF	.39pF	6.8pF	3.9pF	—	680Ω	3.3pF	6.8pF	3.9pF	6.8pF	6.8pF	22 pF	—	3.5T(-6)	-20	-20	-20		—	302-095	302-322		
175-195 MHz	22 pF	56pF	5.6pF	39pF	6.8pF	6.8pF	8.2pF	5.6pF	.33pF	5.6pF	3.9pF	—	1K	2.7pF	5.6pF	3.9pF	5.6pF	6.8pF	6.8pF	22 pF	2.5T(-1)	-2	-2	-2		—	302-095	302-322		
162-175 MHz	22 pF	56 pF	5.6 pF	39 pF	6.8 pF	6.8 pF	8.2 pF	5.6 pF	.33 pF	5.6 pF	3.9 pF	15 pF	1000pF	1K	2.7 pF	5.6 pF	3.9 pF	5.6 pF	6.8 pF	6.8 pF	22 pF	2.5T(-1)	-2	-2	-2		22 K	303-443	303-444	

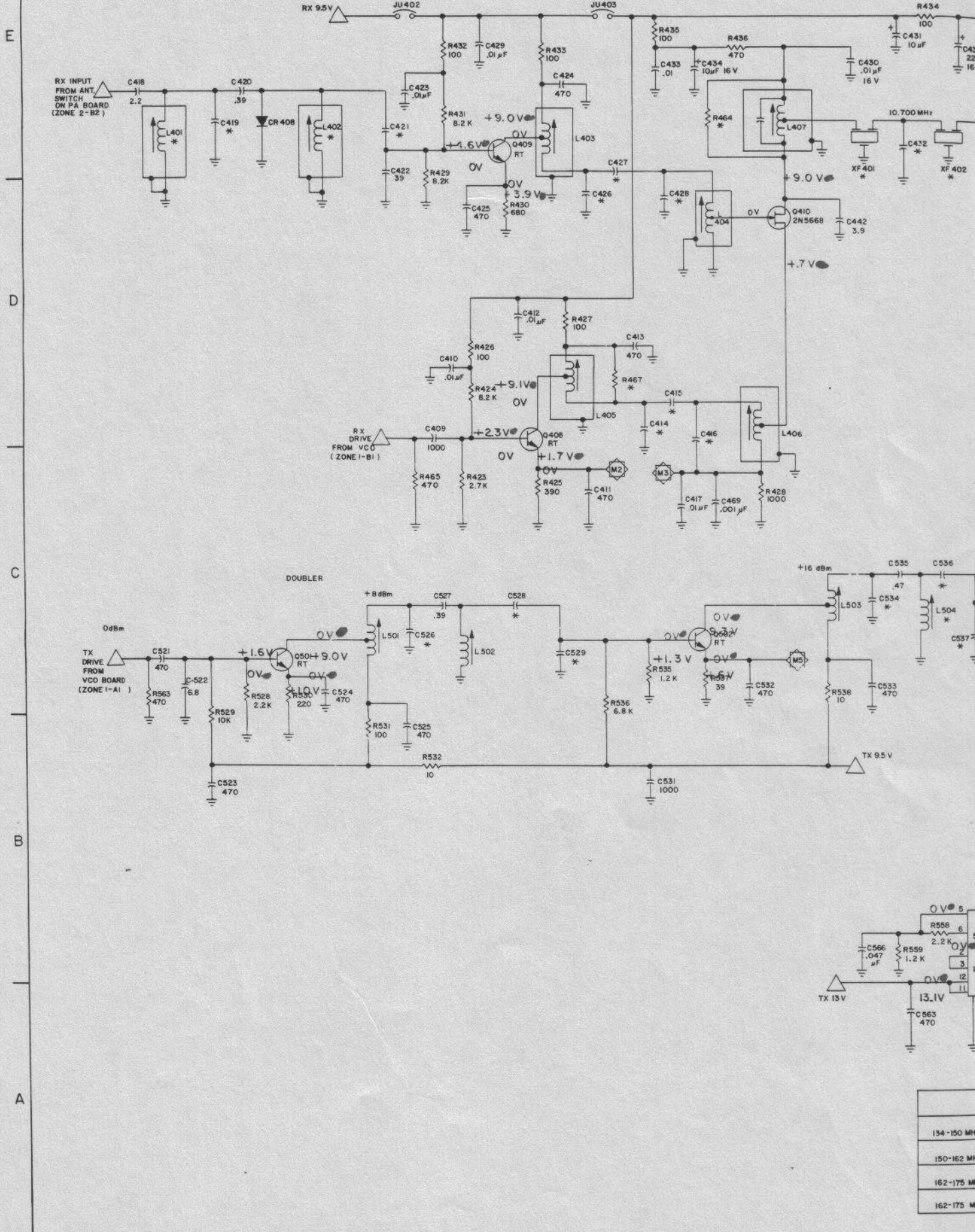

134-150 MHz
150-162 MHz
162-175 MHz
162-175 MHz

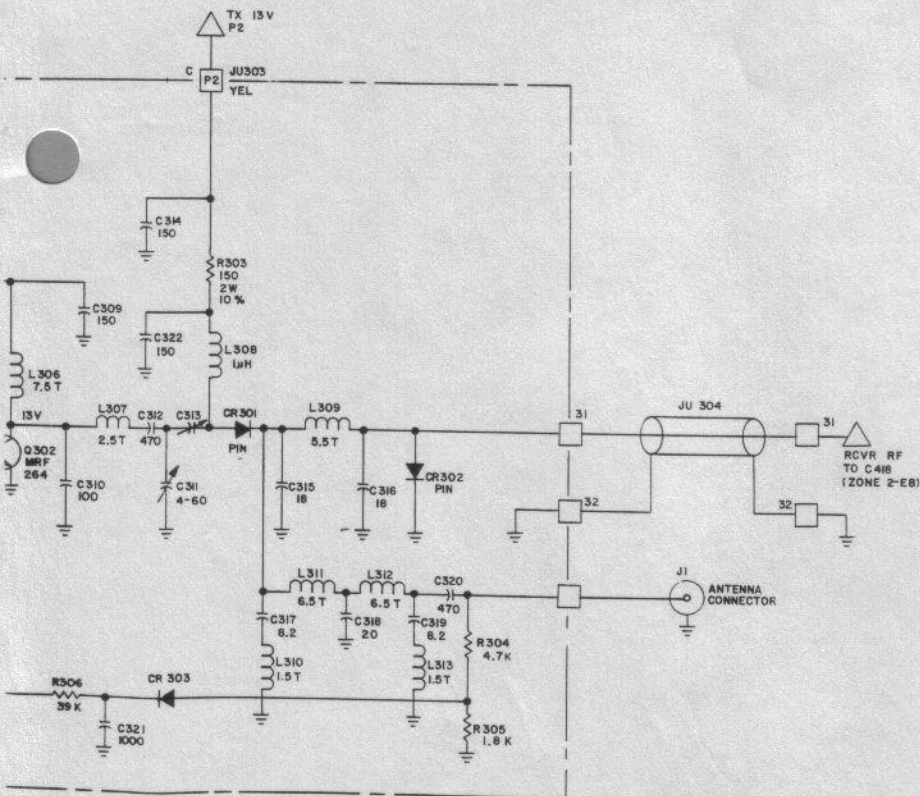
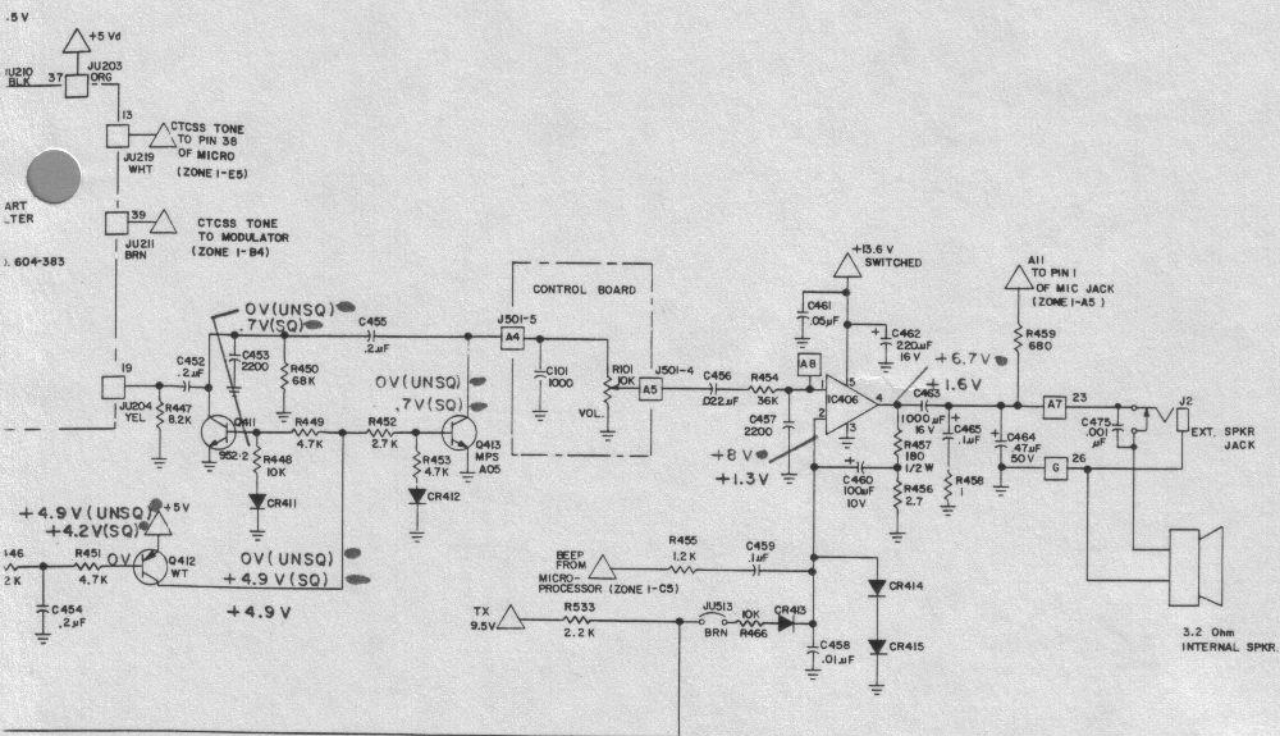

R464	CF401	XF401 XF402	L408	C448	C450	C538	R444	R445
—	302-096	302-322	39μH	82 pF	1000 pF	6.8 pF	13 K	13 K
—	302-096	302-322	39μH	82 pF	1000 pF	3.9 pF	13 K	13 K
—	302-096	302-322	39μH	82 pF	1000 pF	3.9 pF	13 K	13 K
22 K	303-443	303-444	REPLACE WITH 3.9 K RES. R466	68 pF	JU	3.9 pF	15 K	—

BLUE PRINT INDICATES RECEIVE VOLTAGE
RED PRINT INDICATES TRANSMIT VOLTAGE

SCHEMATIC - 704-155Y
SHEET 2

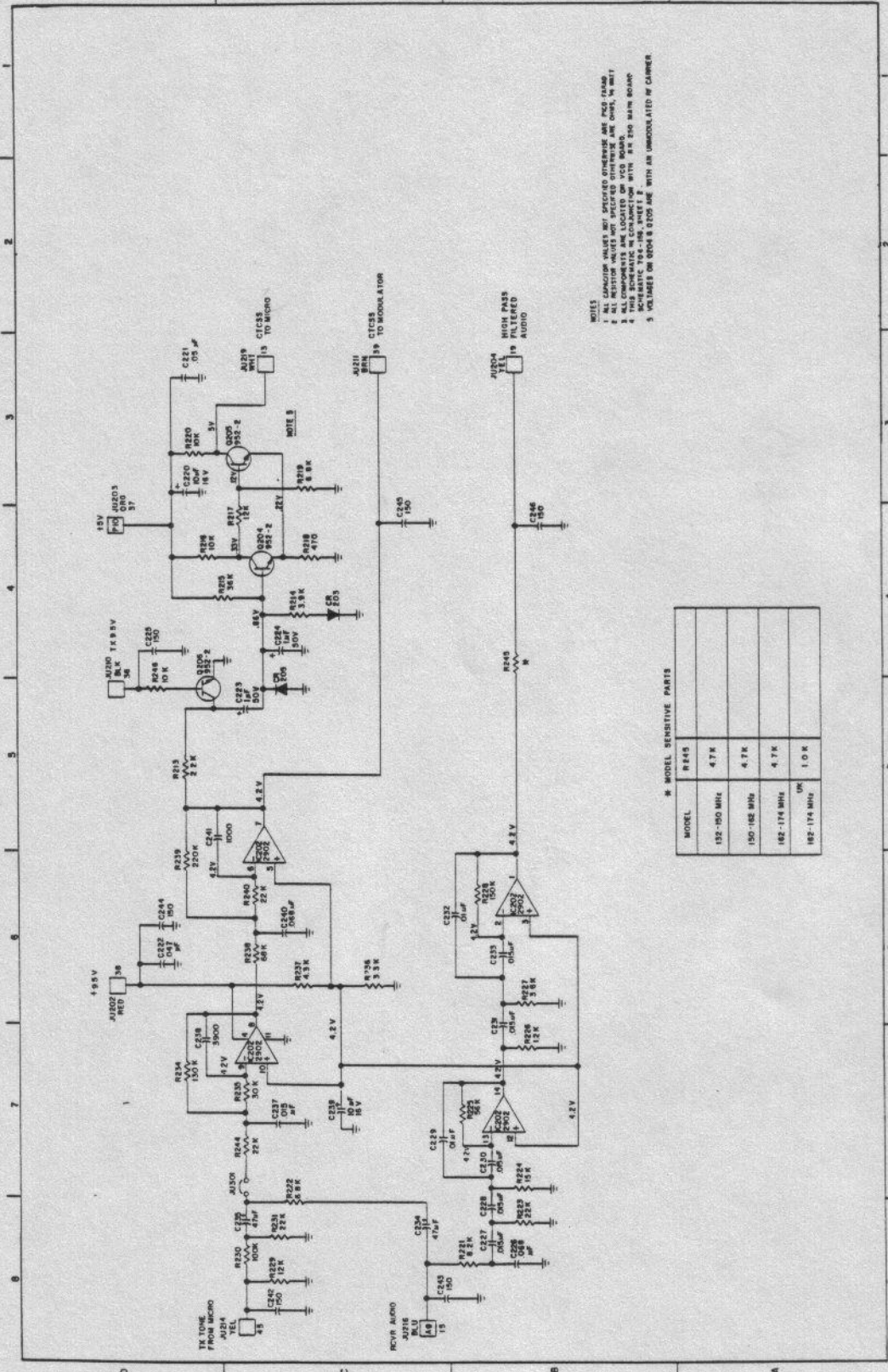

- NOTES
- 1 ALL CAPACITOR VALUES NOT SPECIFIED OTHERWISE ARE PCLD-PLAND
 - 2 ALL RESISTOR VALUES NOT SPECIFIED OTHERWISE ARE OHMS, UNLESS
 - 3 OTHERWISE SPECIFIED
 - 4 ALL DIMENSIONS ARE IN MILLIMETERS UNLESS OTHERWISE SPECIFIED
 - 5 SCHEMATIC TRG-106 SHEET 2
 - 6 VOLUMES ON BOARDS 1205 ARE WITH AN UNMODULATED 100 HZ TONE

* MODEL SENSITIVE PARTS

MODEL	RESIS
152-150 MHz	4.7K
150-152 MHz	4.7K
152-174 MHz	4.7K
152-174 MHz	1.0R

HIGH PASS/LOW PASS FILTER SCHEMATIC

604-383E

SECTION 3 - PARTS LIST

Sections 3-2, 3-3, and 3-4 are parts lists for the RH250 "B" Model radio. Part variations for the WH2516, "A", "C", and "UK" Models are listed in Sections 3-5, 3-7, 3-8, and 3-9 respectively. Parts listed in Sections 3-1 and 3-6 are common for all radios.

3-1 CONTROL BOARD

<u>REFERENCE DESIGNATOR</u>	<u>DESCRIPTION</u>	<u>PART NUMBER</u>	<u>SCHEM. ZONE</u>
<u>CAPACITORS</u> (All capacitors are in pF unless otherwise indicated.)			
C101	1000, 50V, 10%	1538-0102-601	2-D2
C102	.01uF, 25V	1538-0103-804	1-E3
<u>DIODES</u>			
CR101	Silicon, Power	4806-0000-004	1-D7
CR102	Silicon, Power	4806-0000-004	1-D7
CR103	Silicon, Power	4806-0000-004	1-D7
<u>DISPLAYS</u>			
DS101	One digit, yellow	2000-3285-600	1-C7
DS102	One digit, yellow	2000-3285-600	1-C7
LD101	LED, red	4810-1333-801	1-E7
LD102	LED, yellow	4810-1320-501	1-E7
LD103	LED, yellow	4810-1320-501	1-E7
LD104	LED, yellow	4810-1320-501	1-E7
<u>TRANSISTORS</u>			
Q101	NPN	4801-0000-016	1-E7
Q102	NPN	4801-0000-016	1-E7
Q103	NPN	4801-0000-016	1-E7
Q104	NPN	4801-0000-016	1-D7
<u>RESISTORS</u> (All resistors are in ohms, 1/4W, 5%, unless otherwise indicated.)			
R101	Var., 10K Vol. w/Sw. S103 On older models (R101 marked "Korea")	4750-5194-701	2-D2
R102	Var., 10K, Squelch	4751-3294-801	2-D2
R103	100	4750-5194-601	2-D4
R104	100	4704-0101-032	1-E7
R105	100	4704-0101-032	1-E7
R106	100	4704-0101-032	1-E7
R107	100	4704-0101-032	1-D7
R108	10K	4704-0103-032	1-E7
R109	4700	4704-0472-032	1-E7
R110	4700	4704-0472-032	1-E7
R111	4700	4704-0472-032	1-D7
R112	56, 1W, 10%	4711-0560-049	1-D7
<u>SWITCHES</u>			
SW101	Slide, SPDT, Monitor	5113-5154-001	1-C7
SW102	Slide, DPDT, Day/Night	5113-5152-301	1-D7
SW103	Part of R101		1-E3

<u>REFERENCE DESIGNATOR</u>	<u>DESCRIPTION</u>	<u>PART NUMBER</u>	<u>SCHEM. ZONE</u>
<u>CAPACITORS</u>	(All capacitors are in pF unless otherwise indicated.)		
C201	470, 50V	1523-0471-002	1-B2
C202	2.2, NPO	1500-0229-205	1-A2
C203	1000, 50V, 10%	1539-0102-601	1-A2
C204	12, 50V, 10%	1500-0120-505	1-B2
C205	470, 50V	1523-0471-002	1-B2
C206	10uF, 16V, Lytic	1513-0100-002	1-B2
C207	1000, 50V	1523-0102-002	1-B2
C208	6.8, 500V, 5%, NPO	1500-0689-505	1-B2
C209	470, 50V, 10%	1538-0471-601	1-B2
C210	8.2, 500V, 5%, NPO	1500-0829-505	1-B2
C211	470, 50V, 10%	1538-0471-601	1-B2
C212	1000, 50V	1523-0102-002	1-B2
C213	10uF, 16V, Lytic	1513-0100-002	1-B2
C214	.047uF, 50V	1539-0473-708	1-B1
C215	4.7, 500V, 10%, NPO	1500-0479-905	1-B1
C216	1000, 50V, 10%	1538-0102-601	1-B1
C217	1000, 50V, 10%	1538-0102-601	1-B1
C218	10, 50V, 5%, NPO	1500-0100-650	1-B2
C219	10uF, 16V, Lytic	1513-0100-002	1-B1
C220	10uF, 16V, Lytic	1513-0100-002	D3
C221	.05uF, 16V	1502-0505-003	D3
C222	.047uF, 50V	1539-0473-708	D6
C223	1uF, 50V, Lytic	1513-0010-004	D5
C224	1uF, 50V, Lytic	1513-0010-004	C4
*C225	150, 50V	1523-0151-002	D4
C226	.068uF, 100V, 10%, Mylar	1508-0683-610	B8
C227	.015uF, 100V, 5%, Mylar	1508-0153-510	B8
C228	.015uF, 100V, 5%, Mylar	1508-0153-510	B8
C229	.01uF, 100V, 5%, Mylar	1508-0103-510	C7
C230	.015uF, 100V, 5%, Mylar	1508-0153-510	B7
C231	.015uF, 100V, 5%, Mylar	1508-0153-510	B6
C232	.01uF, 100V, 5%, Mylar	1508-0103-510	B6
C233	.015uF, 100V, 5%, Mylar	1503-0153-510	B6
C234	.2uF, 12V	1502-0204-006	C8
C235	.2uF, 12V	1502-0204-006	C8
C236	not used		
C237	.015uF, 100V, 10%, Mylar	1508-0153-510	C7
C238	3900, 100V, 5%, Mylar	1508-0392-510	D7
C239	10uF, 16V, Lytic	1513-0100-002	C7
C240	.068uF, 100V, 10%, Mylar	1508-0683-610	C6
C241	1000, 100V, 5%, Mylar	1508-0102-001	D5
*C242	150, 50V	1523-0151-002	C8

*Indicates that this part is mounted on the solder side of the P.C. Board.

REFERENCE DESIGNATOR	DESCRIPTION	PART NUMBER	SCHEM. ZONE
*C243	150, 50V	1523-0151-002	C8
*C244	150, 50V	1523-0151-002	D6
*C245	150, 50V	1523-0151-002	C4
*C246	150, 50V	1523-0151-002	B4

DIODES

CR201	Varicap	4809-0000-001	1-A2
CR202	Varicap	4809-0000-011	1-B2
CR203	Silicon	4805-1241-200	C4
CR204	Silicon	4805-1241-200	C5
*CR205	Silicon	4805-1241-200	D5

INTEGRATED CIRCUITS

IC201	Dual Modulus Counter	3130-6060-605	1-B1
IC202	OP AMP	3130-3157-637	C7

COILS

L201	Coil	1800-5149-704	1-B2
L202	4.7 uH, choke	1803-3268-211	1-B2
L203	1 uH, choke	1803-3268-210	1-B2
L204	Coil, 4 1/2T, yellow	1803-5125-902	1-B2

TRANSISTORS

Q201	NPN	4801-0000-005	1-A2
Q202	JFET (graded)	4811-0000-020	1-B2
Q203	NPN (red top)	4801-0000-035	1-B2
Q204	NPN	4801-0000-016	C4
Q205	NPN	4801-0000-016	C3
*Q206	NPN	4801-0000-016	C4

RESISTORS (All resistors are ohms, 1/4W, 5%, unless otherwise indicated.)

R201	22K	4704-0223-032	1-B3
R202	4700	4704-0472-032	1-A2
R203	47K	4704-0473-032	1-A3
R204	10K	4704-0103-032	1-A2
R205	270K	4704-0274-032	1-B2
R206	1000	4704-0102-032	1-B2
R207	33	4704-0330-032	1-B2
R208	10K	4704-0103-032	1-B2
R209	4700	4704-0472-032	1-B2
R210	100	4704-0101-032	1-B2
R211	68	4704-0680-032	1-B2

*Indicates that this part is mounted on the solder side of the P.C. Board.

<u>REFERENCE DESIGNATOR</u>	<u>DESCRIPTION</u>	<u>PART NUMBER</u>	<u>SCHEM. ZONE</u>
R212	180	4704-0181-032	1-A2
R213	2200	4704-0222-032	D5
R214	3900	4704-0392-032	C4
R215	36K	4704-0363-032	C4
R216	10K	4704-0103-032	D4
R217	12K	4704-0123-032	C4
R218	470	4704-0471-032	C4
R219	6800	4704-0682-032	C3
R220	10K	4704-0103-032	D3
R221	8200	4704-0822-032	B8
R222	6800	4704-0682-032	C7
R223	22K	4704-0223-032	B8
R224	15K	4704-0153-032	B7
R225	56K	4704-0563-032	B7
R226	1200	4704-0122-032	B7
R227	3600	4704-0362-032	B6
R228	150K	4704-0154-032	B6
R229	12K	4704-0123-032	C8
R230	100K	4704-0104-032	C8
R231	22K	4704-0223-032	C8
R232	replaced with jumper		
R233	33	4704-0330-032	1-B2
R234	130K	4704-0134-032	D7
R235	30K	4704-0303-032	C7
R236	33K	4704-0333-032	C6
R237	43K	4704-0433-032	C6
R238	68K	4704-0683-032	C6
R239	220K	4704-0224-032	C6
R240	22K	4704-0223-032	C6
R241	not used		
R242	not used		
R243	not used		
R244	22K	4704-0223-032	C7
**R245	4700	4704-0472-032	B4
*R246	10K	4704-0103-032	D4

*Indicates that this part is mounted on the solder side of the P.C. Board.

**This part sky-hooked with wire 19 on the P.C. Board.

<u>REFERENCE DESIGNATOR</u>	<u>DESCRIPTION</u>	<u>PART NUMBER</u>	<u>SCHEM. ZONE</u>
<u>CAPACITORS</u> (All capacitors are in pF unless otherwise noted.)			
C301	6-20, Red (variable)	1517-3295-303	2-B4
C302	27, 50V, 5%, NPO	1500-0270-550	2-B4
C303	82, 50V, 5%, NPO	1524-0820-002	2-B4
C304	56, 60V, 5%, NPO	1524-0560-002	2-B4
C305	150, 50V, 20%	1523-0151-002	2-B4
C306	18, 500V, 5%	1500-0180-505	2-B4
C307	2-18 (variable)	1517-0000-001	2-B4
C308	10uF, 25V, Lytic	1513-0100-003	2-B4
C309	150, 50V, 20%	1523-0151-002	2-B3
*C310	100, 250V, 10%	1522-0101-007	2-B3
C311	4-60 (variable)	1517-0000-002	2-B3
C312	470, 50V, 5% (mica)	1506-0471-550	2-B3
C313	4-60 (variable)	1517-0000-002	2-B3
C314	150, 50V, 20%	1523-0151-002	2-C3
C315	18, 500V, 5%	1500-0180-505	2-B3
C316	18, 500V, 5%	1500-0180-505	2-B3
C317	8.2, 500V, 5%, NPO	1500-0829-505	2-B3
C318	20, 500V, 5%	1500-0200-505	2-B3
C319	8.2, 500V, 5%, NPO	1500-0829-505	2-B3
C320	470, 50V, 5% (mica)	1506-0471-550	2-B2
C321	1000, 50V	1523-0102-002	2-A3
C322	150, 50V	1523-0151-002	2-B3
C323	47, 50V, 5%	1524-0470-002	2-B4
<u>DIODES</u>			
CR301	Pin, UM9484	4815-3408-600	2-B3
CR302	Pin, UM9484	4815-3308-600	2-B3
CR303	Hot carrier	4816-3302-200	2-A3
<u>COILS/CHOKES</u>			
FB301	not used		
FB302	Ferrite, bead, w/lead	2502-3293-901	2-B4
FB303	Ferrite, bead, w/lead	2502-3293-901	2-C4
L301	LM-2, 2 1/2T (violet)	1803-5125-901	2-B4
L302	LM-2, 10 1/2T (natural)	1803-5125-912	2-B4
L303	LM02, 3 1/2T (red)	1803-5125-906	2-B4
L304	Choke, 1.8 uH	1803-3268-208	2-B3
L305	Choke, 1.8 uH	1803-3268-208	2-B3
L306	LM-2, 7 1/2T (violet)	1803-5125-913	2-B3
L307	LM-2, 2 1/2T (violet)	1803-5125-901	2-B3
L308	Choke, 1.0 uH	1803-3268-210	2-B3

*Indicates that this part is mounted on the solder side of the P.C. Board.

<u>REFERENCE</u>	<u>DESIGNATOR</u>	<u>DESCRIPTION</u>	<u>PART NUMBER</u>	<u>SCHEM.</u>	<u>ZONE</u>
L309		LM-2, 5 1/2T (green)	1803-5125-905		2-B3
L310		LM-2, 1 1/2T (orange)	1803-5125-907		2-B3
L311		LM-2, 6 1/2T (blue)	1803-5125-909		2-B3
L312		LM-2, 6 1/2T (blue)	1803-5125-909		2-B3
L313		LM-2, 1 1/2T (orange)	1803-5125-907		2-B3

TRANSISTORS

Q301		RF, Power	4804-3411-801		2-B4
Q302		RF, Power	4804-3411-802		2-B3

RESISTORS (All resistors are ohms, 1/4W, 5%, unless otherwise indicated.)

R301		10	4704-0100-032		2-B4
R302		10	4704-0100-032		2-B4
R303		150, 2W, 10%	4701-0151-046		2-C3
R304		4700	4704-0472-032		2-B2
R305		1300	4704-0182-032		2-A2
R306		39K	4704-0393-032		2-A3

3-4-1 MAIN BOARD, RECEIVER SECTION "B" MODEL

<u>REFERENCE DESIGNATOR</u>	<u>DESCRIPTION</u>	<u>PART NUMBER</u>	<u>SCHEM. ZONE</u>
<u>CAPACITORS</u> (All capacitors are in pF unless otherwise indicated.)			
C401	4.7uF, 35V, Lytic	1513-0479-006	1-D4
C402	4.7uF, 35V, Lytic	1513-0479-006	1-D4
C403	4.7uF, 35V, Lytic	1513-0479-006	1-C4
C404	.05uF, 16V	1502-0503-003	1-C4
C405	4.7uF, 35V, Lytic	1513-0479-006	1-C4
C406	100uF, 10V, Lytic	1513-0101-002	1-D5
C407	.01uF, 25V	1538-0103-804	1-C4
C408	2200, 50V, 10%	1538-0222-601	1-C5
C409	1000, 50V, 10%	1538-0102-601	2-D7
C410	.01uF, 25V	1538-0103-804	2-D7
C411	470, 50V, 10%	1538-0471-601	2-C7
C412	.01uF, 25V	1538-0103-804	2-D7
C413	470, 50V, 10%	1538-0471-601	2-C7
C414	6.8, 50V, 10%, NPO	1538-0689-608	2-D7
C415	.47, 10%	1510-0478-900	2-D7
C416	8.2, 50V, 10%, NPO	1538-0829-608	2-D7
C417	.01uF, 25V	1538-0103-804	2-C7
C418	2.2, 10%, NPO	1538-0229-608	2-E8
C419	5.6, 50V, 10%, NPO	1538-0569-608	2-E8
C420	.39, 10%	1510-0398-900	2-E8
C421	8.2, 50V, 10%, NPO	1538-0829-608	2-E7
C422	39, 50V, 5%	1538-0390-508	2-E7
C423	.01uF, 25V	1538-0103-804	2-E7
C424	470, 50V, 10%	1538-0471-601	2-E7
C425	470, 50V, 10%	1538-0471-601	2-D7
C426	6.8, 50V, 10%, NPO	1538-0689-608	2-D7
C427	.39, 10%	1510-0398-900	2-E7
C428	6.8, 50V, 10%, NPO	1538-0689-608	2-D7
C429	.01uF, 25V	1538-0103-804	2-E7
C430	.01uF, 25V	1538-0103-804	2-E6
C431	10uF, 16V, Lytic	1513-0100-002	2-E6
C432	3.9, 500V	1500-0399-205	2-E6
C433	.01uF, 25V	1538-0103-804	2-E7
C434	10uF, 16V, Lytic	1513-0100-002	2-E7
C435	.01uF, 25V	1538-0103-804	2-D6
C436	68, 50V, 5%, NPO	1538-0680-509	2-E5
C437	150, 50V, 10%	1538-0151-601	2-E5
C438	22uF, 16V, Lytic	1513-0220-002	2-E6
C439	.05uF, 16V	1502-0503-003	2-E6
C440	.05uF, 16V	1502-0503-003	2-E5
C441	.047uF, 50V	1539-0473-708	2-E5
C442	3.9, 500V	1500-0399-205	2-D6
C443	150, 50V, 10%	1538-0102-601	2-D5

<u>REFERENCE</u> <u>DESIGNATOR</u>	<u>DESCRIPTION</u>	<u>PART NUMBER</u>	<u>SCHEM.</u> <u>ZONE</u>
C444	1000, 50V, 10%	1538-0102-601	2-D5
C445	.47uF, 50V, Lytic	1513-3302-005	2-D5
C446	4700, 50V, 10%	1538-0472-626	2-D5
C447	470, 50V, 10%	1538-0471-601	2-D4
C448	100, 50V, 5%	1538-0101-524	2-D5
C449	1000, 50V, 10%	1538-0102-601	2-D4
C450	1000, 50V, 10%	1538-0102-601	2-D4
C451	1000, 50V, 10%	1538-0102-601	2-D4
C452	.2uF, 12V	1502-0204-006	2-D3
C453	2200, 50V, 10%	1538-0222-601	2-D3
C454	.2uF, 12V	1502-0204-006	2-D3
C455	.2uF, 12V	1502-0204-006	2-D3
C456	.022uF, 25V	1538-0223-805	2-D2
C457	2200, 100V, 5%, Mylar	1508-0222-510	2-D2
C458	.01uF, 25V	1538-0103-804	2-D2
C459	.1uF, 12V	1502-0104-005	2-D2
C460	100uF, 10V, Lytic	1513-0101-001	2-D2
C461	.05uF, 25V	1502-0503-004	2-F2
C462	220uF, 16V, Lytic	1513-3254-711	1-E2
C463	1000uF, 16V, Lytic	1513-3254-704	2-D2
C464	.47uF, 50V, Lytic	1513-3302-005	2-D1
C465	.1uF, 12V	1502-0104-005	2-D1
C466	not used in these models		
*C467	470, 50V	1523-0471-002	1-D6
*C468	470, 50V	1523-0471-002	2-D5
*C469	1000, 50V, 10%	1538-0102-601	2-C6
C470	47uF, 10V, Lytic	1513-0470-001	1-C5
*C471	150, 50V	1523-0151-002	1-E6
*C472	used only in "UK" Model		2-E5
*C473	150, 50V	1523-0151-002	2-D4
*C474	150, 50V	1523-0151-002	2-D4

FILTERS

CF401	Ceramic, 455 kHz	2700-3209-500	2-E5
-------	------------------	---------------	------

DIODES

CR401	Silicon	4805-1241-200	1-D4
CR402	Silicon	4805-1241-200	1-D4
CR403	36V, Zener, 5%	4808-0000-053	1-D4
CR404	Silicon	4805-1241-200	1-D4
CR405	Silicon	4805-1241-200	1-D4
CR406	not used		
CR407	Germanium	4807-1233-900	1-D5
CR408	Silicon	4805-1241-200	2-E8
CR409	Silicon	4805-1241-200	2-D5
CR410	Silicon	4805-1241-200	2-D5

*Indicates that this part is mounted on the solder side of the P.C. Board.

<u>REFERENCE</u> <u>DESIGNATOR</u>	<u>DESCRIPTION</u>	<u>PART NUMBER</u>	<u>SCHEM.</u> <u>ZONE</u>
CR411	Germanium	4807-1233-900	2-D3
CR412	Germanium	4807-1233-900	2-D3
CR413	Silicon	4805-1241-200	2-D2
CR414	Silicon	4805-1241-200	2-D2
CR415	Silicon	4805-1241-200	2-D2
CR416	not used in these models		

INTEGRATED CIRCUITS

IC401	EAROM, memory	3130-3157-663	1-D4
IC402	Memory Buffer	3813-3193-533	1-D4
IC403	Microprocessor	3130-6060-316	1-D5
IC404	BCD to 7-Seg driver	3130-3193-531	1-C6
IC405	IF Amp, 2nd mixer, Det	3130-6056-500	2-E5
IC406	Audio Amp	3130-5407-602	2-D2

COILS/CHOKES

L401	Coil, orange	1800-3152-020	2-E8
L402	Coil, orange	1800-3152-020	2-E8
L403	Coil, pink	1800-3152-036	2-E7
L404	Coil, green	1800-3152-037	2-D7
L405	Coil, green	1800-3152-037	2-D7
L406	Coil, green	1800-3152-037	2-D6
L407	Coil, 10.7 MEz	1800-6055-902	2-E6
L408	Choke, 39 uH	1803-3268-201	2-E6
L409	Coil, 455 kHz	1800-6055-801	2-E4

TRANSISTORS

Q401	NPN	4801-0000-005	1-C4
Q402	NPN	4801-0000-005	1-C4
Q403	NPN	4801-0000-005	1-C4
Q404	used only in WH2516 Model		
Q405	used only in WH2516 Model		
Q406	NPN	4801-0000-016	1-B5
Q407	NPN	4801-0000-016	1-B6
Q408	NPN, Red Top	4801-0000-035	2-D7
Q409	NPN, Red Top	4801-0000-035	2-E7
Q410	JFET	4811-0000-030	2-D6
Q411	NPN	4801-0000-016	2-D3
Q412	PNP, White Top	4801-0000-060	2-D3
Q413	NPN	4801-0000-005	2-D2
Q414	not used in these models		

<u>REFERENCE</u> <u>DESIGNATOR</u>	<u>DESCRIPTION</u>	<u>PART NUMBER</u>	<u>SCHEM.</u> <u>ZONE</u>
<u>RESISTORS</u> (All resistors are in ohms, 1/4W, 5%, unless otherwise indicated.)			
R401	390	4704-0391-032	1-D4
R402	1200	4704-0122-032	1-D4
R403	1000	4704-0102-032	1-C4
R404	820	4704-0821-032	1-C4
R405	4700	4704-0472-032	1-C4
R406	4700	4704-0472-032	1-B6
R407	100	4704-0101-032	1-B6
R408	100	4704-0101-032	1-B6
R409	100	4704-0101-032	1-C6
R410	100	4704-0101-032	1-C6
R411	100	4704-0101-032	1-C6
R412	100	4704-0101-032	1-C6
R413	100	4704-0101-032	1-C6
R414	100	4704-0101-032	1-B6
R415	100	4704-0101-032	1-B6
R416	22K	4704-0223-032	1-B5
R417	15K	4704-0153-032	1-C4
R418	used only in WH2516 model		
R419	used only in WH2516 model		
R420	used only in Wh2516 model		
R421	4700	4704-0472-032	1-B5
R422	1000	4704-0102-032	1-C5
R423	2700	4704-0272-032	2-C7
R424	8200	4704-0822-032	2-D7
R425	390	4704-0391-032	2-C7
R426	100	4704-0101-032	2-D7
R427	100	4704-0101-032	2-D7
R428	1000	4704-0102-032	2-C6
R429	8200	4704-0822-032	2-E7
R430	680	4704-0681-032	2-D7
R431	8200	4704-0822-032	2-E7
R432	100	4704-0101-032	2-E7
R433	100	4704-0101-032	2-E7
R434	100	4704-0101-032	2-E6
R435	100	4704-0101-032	2-E7
R436	470	4704-0471-032	2-E6
R437	100	4704-0101-032	2-D5
R438	2200	4704-0222-032	2-D5
R439	180K	4704-0184-032	2-D5
R440	47K	4704-0473-032	2-D5
R441	330K	4704-0334-032	2-D5
R442	1000	4704-0102-032	2-E4
R443	68K	4704-0683-032	2-E5
R444	13K	4704-0133-032	2-D4
R445	13K	4704-0133-032	2-D4
R446	1200	4704-0122-032	2-D3
R447	8200	4704-0822-032	2-D3

<u>REFERENCE DESIGNATOR</u>	<u>DESCRIPTION</u>	<u>PART NUMBER</u>	<u>SCHEM. ZONE</u>
R448	10K	4704-0103-032	2-D3
R449	4700	4704-0472-032	2-D3
R450	68K	4704-0683-032	2-D3
R451	4700	4704-0472-032	2-D3
R452	2700	4704-0272-032	2-D3
R453	4700	4704-0472-032	2-D3
R454	36K	4704-0363-032	2-D2
R455	1200	4704-0122-032	2-D2
R456	6.2	4704-0629-032	2-D2
R457	220 1/2W	4704-0221-034	2-D2
R458	1	4704-0010-032	2-D2
R459	680	4704-0681-032	2-D1
R460	not used in these models		
R461	24K	4704-0243-032	1-D5
R462	16K	4704-0163-032	1-D5
R463	56K	4704-0563-032	1-D5
*R464	used on UK Model		2-E5
*R465	470	4704-0471-032	2-D7

TRANSFORMER

T401	Drum/Ring	5604-5151-200	1-D4
------	-----------	---------------	------

CRYSTAL FILTERS

XF401	Filter, 10.7 MHz	2705-3232-200	2-E6
XF402	Filter, 10.7 MHz	(matched pair)	2-E6

CRYSTALS

Y401	3.579 MHz	2342-3284-400	1-D5
Y402	10.245 MHz	2301-3151-601	2-E5

*Indicates that this part is mounted on the solder side of the P.C. Board.

<u>REFERENCE DESIGNATOR</u>	<u>DESCRIPTION</u>	<u>PART NUMBER</u>	<u>SCHEM. ZONE</u>
<u>CAPACITORS</u> (All capacitors are in pF unless otherwise indicated.)			
C501	150, 50V, 10%	1538-0151-601	1-A5
C502	.2uF, 12V	1502-0204-006	1-A5
C503	.02uF, 25V	1538-0223-805	1-A5
C504	.2uF, 12V	1502-0204-006	1-B4
C505	.015uF, 100V, 5%, Mylar	1508-0153-510	1-A4
C506	4700, 100V, 5%, Mylar	1508-0472-510	1-A4
C507	470, 50V	1523-0471-002	1-A4
C508	10uF, 16V, Lytic	1513-0100-002	1-A4
C509	.015uF, 100V, 5%, Mylar	1508-0153-510	1-A4
C510	1000, 100V, 5%, Mylar	1508-0102-510	1-A3
C511	.2uF, 12V	1502-0204-006	1-A3
C512	470, 50V, 10%	1538-0471-601	1-A3
C513	.001uF, 100V, 10%, Mylar	1503-0102-001	1-C3
C514	470, 50V, 10%	1538-0471-601	1-B3
C515	10uF, 16V, Lytic	1513-0100-002	1-B3
C516	1000, 16V, Lytic	1513-3254-704	1-B3
C517	.015uF, 100V, 5%, Mylar	1508-0153-510	1-B3
C518	.22uF, Mylar	1508-3300-302	1-B3
C519	470, 50V	1523-0471-002	1-B3
C520	.015uF, 100V, 5%, Mylar	1508-0153-510	1-B3
C521	470, 50V, 10%	1538-0471-601	2-C8
C522	6.8, 50V, 10%, NPO	1538-0689-608	2-C8
C523	470, 50V, 10%	1538-0471-601	2-B8
C524	470, 50V, 10%	1538-0471-601	2-C8
C525	470, 50V, 10%	1538-0471-601	2-B7
C526	3.3, 50V, 10%, NPO	1538-0339-608	2-C7
C527	.39, 10%	1510-0398-900	2-C7
C528	6.8, 50V, 10%, NPO	1538-0680-608	2-C7
C529	3.9, 50V, 10%, NPO	1538-0399-608	2-C7
C530	100uF, 16V, Lytic	1513-0101-002	2-B7
C531	1000, 50V, 10%	1538-0102-601	2-B7
C532	470, 50V	1523-0471-002	2-C6
C533	470, 50V, 10%	1538-0471-601	2-C6
C534	6.8, 50V, 10%, NPO	1538-0689-608	2-C6
C535	.47, 10%	1510-0478-900	2-C6
C536	6.8, 50V, 10%, NPO	1538-0689-608	2-C6
C537	22, 50V, 5%, NPO	1538-0220-508	2-C6
C538	3.9, 50V, 5%, NPO	1500-0399-905	2-C5
C539	470, 50V	1523-0471-002	2-C5
C540	.05uF, 16V	1502-0503-003	2-B5
C541	47uF, 10V, Lytic	1523-0470-001	1-D1
C542	.05uF, 16V	1502-0503-003	1-D1
C543	56, 50V, 5%, NPO	1538-0560-509	1-C2
C544	27, 50V, 5%, NPO	1538-0270-508	1-C2
C545	3-12, Trimmer	1517-5165-001	1-C2

REFERENCE DESIGNATOR	DESCRIPTION	PART NUMBER	SCHEM. ZONE
C546	4.7uF, 35V, Lytic	1513-0479-006	1-D2
C547	1000, 50V	1523-0102-002	1-D2
C548	1000, 50V, 10%	1538-0102-601	1-E3
C549	1uF, 50V, 10%, Lytic	1513-0010-004	1-E3
C550	470uF, 6.3V, Lytic	1513-3254-709	1-D2
C551	1uF, 50V, Lytic	1513-0010-004	1-E3
C552	1000, 50V	1523-0102-002	1-E3
C553	1000, 50V, 10%	1538-0102-601	1-E2
C554	1000, 50V, 10%	1538-0102-601	1-D2
C555	.05uF, 16V	1502-0503-003	1-E1
C556	10uF, 16V, Lytic	1513-0100-002	1-E1
C557	10uF, 16V, Lytic	1513-0100-002	1-E1
C558	1000, 50V, 10%	1538-0102-601	1-D3
C559	470, 50V	1523-0471-002	1-D3
C560	220uF, 16V, Lytic	1513-3254-711	1-E4
C561	470, 50V	1523-0471-002	1-E4
C562	470, 50V, 10%	1538-0471-601	2-B5
C563	470, 50V, 10%	1538-0471-601	2-A6
C564	.047uF, 50V	1539-0473-708	2-A6
C565	470, 50V, 10%	1538-0471-601	2-A6
C566	.047uF, 50V	1539-0473-708	2-B6
*C567	150, 50V	1523-0151-002	1-D3
*C568	150, 50V	1523-0151-002	1-B6
*C569	150, 50V	1523-0151-002	1-B5
*C570	used only in "C" and "UK" Models		2-C6

DIODES

CR501	Silicon	4805-1241-200	1-B5
CR502	Silicon	4805-1241-200	1-B5
CR503	Germanium	4807-1233-900	1-C6
CR504	Germanium	4807-1233-900	1-C2
CR505	Silicon	4805-1241-200	1-D3
CR506	Silicon	4805-1241-200	1-D2
CR507	Silicon	4805-1241-200	1-D3
CR508	Silicon	4805-1241-200	1-E2
CR509	Silicon	4805-1241-200	1-D2
CR510	Silicon, 3 Amp	4806-0000-005	1-E4
*CR511	Silicon	4805-1241-200	1-D3

FERRITE BEADS

FB501	Ferrite Beads w/leads	2502-3293-901	2-C6
-------	-----------------------	---------------	------

*Indicates that this part is mounted on the solder side of the P.C. Board.

<u>REFERENCE</u>	<u>DESCRIPTION</u>	<u>PART NUMBER</u>	<u>SCHEM.</u>	<u>ZONE</u>
------------------	--------------------	--------------------	---------------	-------------

INTEGRATED
CIRCUITS

IC501	Quad OP Amp	3130-3157-637		1-A4
IC502	BIMOS OP Amp	3130-3167-914		1-B3
IC503	CMOS Synthesizer	3130-6068-000		1-C5
IC504	5V Regulator, 1 Amp, 5%	3130-0000-022		1-E1
IC505	8V Regulator, 5%	3130-0000-021		1-E2
IC506	IC Regulator, Variable	3130-3157-655		2-B6

COILS

L501	Coil, yellow	1800-3152-035		2-C7
L502	Coil, orange	1800-3152-020		2-C7
L503	Coil, orange	1800-3152-034		2-C6
L504	Coil, orange	1800-3152-020		2-C6
L505	Coil, Blue, 6 1/2T	1803-5125-909		2-C5
L506	Coil, Natural, 10 1/2T	1803-5125-912		2-C5
L507	coil, 330 uH	1803-3268-212		1-C2

TRANSISTORS

Q501	NPN, Red Top	4801-0000-035		2-C8
Q502	NPN, Red Top	4801-0000-035		2-C7
Q503	NPN, Pre-driver	4801-0000-030		2-C6
Q504	Darlington	4814-0000-002		1-D3
Q505	PNP, White Top	4801-0000-060		1-D3
Q506	NPN	4801-0000-016		1-D2
Q507	NPN	4801-0000-016		1-D2
Q508	PNP, White Top	4801-0000-060		1-E3
Q509	NPN	4801-0000-016		1-D3
Q510	PNP	4801-0000-001		1-D3

RESISTORS (All resistors are in ohms, 1/4W, 5%, unless otherwise indicated.)

R501	470	4704-0471-032		1-B5
R502	36K	4704-0363-032		1-A5
R503	470K	4704-0474-032		1-A5
R504	33K	4704-0333-032		1-A5
R505	330K	4704-0334-032		1-A4
R506	4700	4704-0472-032		1-A4
R507	22K	4704-0223-032		1-A4
R508	22K	4704-0223-032		1-B4
R509	15K	4704-0153-032		1-B4
R510	2700	4704-0272-032		1-A4
R511	2700, 2%	4704-0272-022		1-A4
R512	3600, 2%	4704-0362-022		1-A4
R513	22K	4704-0223-032		1-A4
R514	12K	4704-0123-032		1-A4
R515	15K	4704-0153-032		1-B3
R516	10K, variable	4751-0103-001		1-A3

REFERENCE DESIGNATOR	DESCRIPTION	PART NUMBER	SCHEM. ZONE
R517	10K	4704-0103-032	1-A3
R518	47K	4704-0473-032	1-A3
R519	22K	4704-0223-032	1-A3
R520	47K	4704-0473-032	1-A3
R521	deleted, changed to L507		
R522	replaced with jumper		
R523	5600	4704-0562-032	1-B3
R524	6800	4704-0682-032	1-B3
R525	22K	4704-0223-032	1-B3
R526	10K	4704-0103-032	1-B3
R527	39	4704-0390-032	1-C3
R528	2200	4704-0222-032	2-C8
R529	10K	4704-0103-032	2-C8
R530	220	4704-0221-032	2-C8
R531	100	4704-0101-032	2-B8
R532	10	4704-0100-032	2-B7
R533	2200	4704-0222-032	2-D2
R534	not used in these models		
R535	1200	4704-0122-032	2-C7
R536	6800	4704-0682-032	2-C7
R537	39	4704-0390-032	2-C7
R538	10	4704-0100-032	2-C6
R539	56	4704-0560-032	2-C6
R540	10	4704-0100-032	2-B5
R541	10K	4704-0103-032	2-C5
R542	1	4704-0010-032	1-D1
R543	1200	4704-0122-032	1-D3
R544	2.7	4704-0279-032	1-C3
R545	100, 2W, 5%	4707-0101-031	1-C2
R546	2200	4704-0222-032	1-D3
R547	10K	4704-0103-032	1-D3
R548	8200	4704-0822-032	1-D2
R549	10K	4704-0103-032	1-D1
R550	2200	4704-0222-032	1-E2
R551	3.9, 5W, 10%	4707-0399-043	1-E2
R552	10K	4704-0103-032	1-E2
R553	2200	4704-0222-032	1-D2
R554	10K	4704-0103-032	1-D2
R555	68K	4704-0683-032	1-D3
R556	1200	4704-0122-032	1-D3
R557	10K	4704-0103-032	1-D3
R558	2200	4704-0222-032	2-B6
R559	1200	4704-0122-032	2-B6
R560	100K, variable	4751-0104-012	2-A5
R561	10K, variable	4751-0103-001	1-B5
R562	not used in these models		
R563	470	4704-0471-032	2-C8

<u>REFERENCE DESIGNATOR</u>	<u>DESCRIPTION</u>	<u>PART NUMBER</u>	<u>SCHEM. ZONE</u>
<u>THERMISTOR</u>			
RT501	Thermistor	5300-0000-001	1-C3
<u>CRYSTAL</u>			
Y501	10.240 MHz	2338-3300-501	1-C3

<u>REFERENCE DESIGNATOR</u>	<u>DESCRIPTION</u>	<u>PART NUMBER</u>	<u>SCHEM. ZONE</u>
CR406	Zener, 6.8 V	4804-0000-042	**
IC401	EAROM	3130-1355-200	1-D4
IC403	Microprocessor	3130-6105-102	1-D5
Q404	Transistor, NPN	4801-0000-016	**
Q405	Transistor, NPN	4801-0000-016	**
R418	Resistor, 1.2K, 5%, 1/4W	4704-0122-032	**
R419	Resistor, 1.2K, 5%, 1/4W	4704-0122-032	**
R420	Resistor, 10K, 5%, 1/4W	4704-0103-032	**

*NOTE: Used in conjunction with Sections 3-2, 3-3, and 3-4 plus "A", "C", and "UK" Part Variations lists - if applicable.

**NOTE: See Figure 6 - Reset Circuit of WH2516.

3-6 CHASSIS PARTS AND MISCELLANEOUS

<u>REFERENCE DESIGNATOR</u>	<u>DESCRIPTION</u>	<u>PART NUMBER</u>	<u>SCHEM ZONE</u>
C1	39pF, 50V, 5%, NPO	1538-0390-500	1-E4
C2	150, 50V	1523-0151-002	1-B5
C3	150, 50V	1523-0151-002	1-A6
C4	150, 50V	1523-0151-002	1-A6
C5	150, 50V	1523-0151-002	1-A6
J1	Antenna Jack	2105-0000-020	2-B2
J2	Ext. Spkr Jack 3.5mm	2101-3430-302	2-D1
J3	Power Plug Housing	2109-5120-403	1-E4
J4	Mic Connector, 5-Pin	2105-0000-023	1-A6
KB1	Keyboard	2001-6066-706	1-C7
LD1	Keyboard Lamp Assembly (includes retainer)	7011-1281-000	1-C7
SPK1	Spkr, 4 in. Sq., 3.2 ohm	1301-3299-603	2-D1
	Pins, Female, for J3	2107-3244-102	
	Power Plug Retainer	1400-1325-400	
	Spkr Fasteners (4 used)	2853-3275-901	
	Front Panel Mtg Brkt	1400-7060-600	
	Front Panel (less lens)	1511-7059-810	
	Display Lens	3900-5156-007	
	Top Case (beige)	1411-5178-404	
	Top Case (gray)	1411-5178-405	
	Ferrules, used on Top Case (4 used)	2859-1332-700	
	Bottom Case (beige)	1411-7053-008	
	Bottom Case (gray)	1411-7053-014	
	Case screw, black pluscrew (4 used)	2816-3298-702	
	Case screw, sheetmetal (1 used)	2809-0375-012	
	Knobs, Volume and Squelch	2402-6067-203	
	Mobile Mtg Knobs	2402-5148-702	
	Mobile Mtg Brkt	1400-6070-801	
	Mobile Mtg Brkt (black)	1400-6070-804	
	Mic Hang-up Clip	2830-3318-100	
	5 Amp Fuse, for Pwr Cord	5106-0000-008	
	10 Cont. Jack Keyboard	2105-3442-501	
	14 Cont. Jack Flex Cable	2105-3299-202	
	9 Cont. Jack Flex Cable	2105-3299-205	
	Shield Can (6 used)	2508-1288-901	
	Heatsink (used on Q503)	5400-1329-000	
	Crystal Clip (used on Y501)	2830-6073-500	

The components listed for this model differ in value and part number from the "B" Model Parts List but retain the same reference designator.

<u>REFERENCE DESIGNATOR</u>	<u>DESCRIPTION</u>	<u>PART NUMBER</u>	<u>SCHEM. ZONE</u>
C208	22pF, 50V, 5%	1500-0220-550	1-B2
C210	22pF, 50V, 5%	1500-0220-550	1-B2
L201	coil	1800-5149-706	1-B2
C303	150pF, 50V	1523-0151-002	2-B4
C414	8.2pF, 50V, 10%	1538-0829-608	2-D7
C416	10pF, 50V, 5%	1538-0100-508	2-D7
C419	6.8pF, 50V, 10%	1538-0689-608	2-E8
C421	10pF, 50V, 5%	1538-0100-508	2-E7
C426	8.2pF, 50V, 10%	1538-0829-608	2-D7
C428	8.2pF, 50V, 10%	1538-0829-608	2-D7
C526	4.7pF, 50V, 10%	1538-0479-608	2-C7
C528	10pF, 50V, 5%	1538-0100-508	2-C7
C529	4.7pF, 50V, 10%	1538-0479-608	2-C7
C534	10pF, 50V, 5%	1538-0100-508	2-C6
C536	8.2pF, 50V, 10%	1538-0829-608	2-C6
C537	27pF, 50V, 5%	1538-0270-509	2-C6
C538	6.8pF	1500-0689-505	2-C5

3-8 "C" MODEL PART VARIATIONS

The components listed for this model differ in value and part number from the "B" Model Parts List but retain the same reference designator.

<u>REFERENCE DESIGNATOR</u>	<u>DESCRIPTION</u>	<u>PART NUMBER</u>	<u>SCHEM. ZONE</u>
C204	10pF, 500V, 5%	1500-0100-805	1-B2
C218	4.7pF, 500V, 5%	1500-0479-505	1-B2
C302	22pF, 50V, 5%	1500-0220-550	2-B4
C303	56pF, 50V, 5%	1524-0560-002	2-B4
L303	choke, 2.5T	1803-5125-901	2-B4
C414	56.pF, 50V, 10%	1538-0569-608	2-D7
C415	.39pF, 10%	1510-0398-900	2-D7
C416	6.8pF, 50V, 10%	1538-0689-608	2-D7
C419	6.8pF, 50V, 10%	1538-0689-608	2-E8
C426	5.6pF, 50V, 10%	1538-0569-618	2-D7
C427	.33pF, 10%	1510-0338-900	2-E7
C428	5.6pF, 50V, 10%	1538-0569-608	2-D7
L401	coil, red	1800-3152-002	2-E8
L402	coil, red	1800-3152-002	2-E8
C526	2.7pF, 50V, 10%	1538-0270-608	2-C7
C528	5.6pF, 50V, 10%	1538-0569-608	2-C7
C534	5.6pF, 50V, 10%	1538-0569-608	2-C6
C536	8.2pF, 50V, 10%	1538-0829-608	2-C6
C537	6.8pF, 50V, 10%	1538-0689-608	2-C6
*C570	22pF, 50V, 5%	1500-0220-550	2-C6
L504	coil, red	1800-3152-002	2-C6

*Indicates that this part is mounted on the solder side of the P.C. Board.

3-9 "UK" MODEL PART VARIATIONS

The components listed for this model differ in value and part number from the "B" Model Parts List but retain the same reference designator.

<u>REFERENCE DESIGNATOR</u>	<u>DESCRIPTION</u>	<u>PART NUMBER</u>	<u>SCHEM. ZONE</u>
C204	10pF, 500V, 5%	1500-0100-805	1-B2
C218	4.7pF, 500V, 5%	1500-0479-505	1-B2
R245	1.0K, 1/4W, 5%	4704-0102-032	B-4
C302	22pF, 50V, 5%	1500-0220-550	2-B4
C303	56pF, 50V, 5%	1524-0560-002	2-B4
L303	choke, 2.5T	1803-5125-901	2-B4
C414	5.6pF, 50V, 10%	1538-0569-608	2-D7
C415	.39pF, 10%	1510-0398-900	2-D7
C416	6.8pF, 50V, 10%	1538-0689-608	2-D7
C419	6.8pF, 50V, 10%	1538-0689-608	2-E8
C426	5.6pF, 50V, 10%	1538-0569-608	2-D7
C427	.33pF, 10%	1510-0338-900	2-E7
C428	5.6pF, 50V, 10%	1538-0569-608	2-D7
C450	Replaced with jumper wire		
*C472	1000pF, 50V, 10%	1538-0102-601	2-E5
CF401	Ceramic Filter	2700-3344-300	2-E5
**IC403	Microprocessor	3130-6060-317	1-D5
L408	Replace with 3.8K, 1/4W, 5% (R466)	4704-0392-032	2-E6
R444	15K, 1/4W, 5%	4704-0153-032	2-D4
R445	not used		
*R464	22K, 1/4W, 5%	4704-0153-032	2-E7
XF401			
XF402	xtal filter (pair)	2705-3344-400	2-E6
C513	.022uF mylar	1508-0223-510	1-C3
C517	.0068uF mylar	1508-0682-510	1-B3
C526	2.7pF, 50V, 10%	1538-0270-608	2-C7
C528	5.6pF, 50V, 10%	1538-0569-608	2-C7
C534	5.6pF, 50V, 10%	1538-0569-608	2-C7
C536	8.2pF, 50V, 10%	1538-0829-608	2-C6
C537	6.8pF, 50V, 10%	1538-0689-608	2-C7
*C570	22pF, 50V, 5%	1500-0220-550	2-C6
L504	coil, red	1800-3152-002	2-C6
R521	15K, 1/4W, 5%	4704-0153-032	1-C2
R522	15K, 1/4W, 5%	4704-0153-032	1-C3
R525	33K, 1/4W, 5%	4704-0333-032	1-B3
Y501	crystal, 12.8 MHz	2338-3300-502	1-C3

*Indicates that this part is mounted on the solder side of the P.C. Board.

**IC403 for WH2516UK is P/N 3130-6105-102.

Alphabetic Listing of Abbreviations used in Service Manual

BCD	binary-coded decimal
CTCSS	continuous tone coded squelch system
EAROM	electrically alterable read-only memory
IF	intermediate frequency
PROM	programmable read-only memory
RX	receiver
SINAD	signal-to-noise-and-distortion
SYNTH	synthesizer
TX	transmitter
uP	microprocessor

Description of Terms used in Manual

Adjacent Channel Desensitization	Decibel ratio of two signals' power; a wanted signal and an unwanted signal on an adjacent channel. The wanted signal is modulated with 3 kHz deviation of 1 kHz tone and the unwanted signal is modulated with 3 kHz deviation of 400 Hz tone.
Channel Spacing	Minimum frequency separation of two adjacent channels.
CTCSS Sensitivity	Maximum allowable signal level needed to allow a 95% decoder success rate. Signal has 3 kHz deviation of 1 kHz tone and 750 Hz deviation of the CTCSS tone.
Frequency Separation	Maximum allowable difference between the lowest frequency and the highest frequency.
Image Rejection	Power ratio between two signals, a wanted signal and an unwanted signal. The unwanted signal degrades the wanted signal's SINAD by 6 dB and is located at two frequencies. One is at the carrier frequency minus 42.8 MHz. The other is at the carrier frequency minus 910 kHz.
Modulation Acceptance Bandwidth	The maximum a received signal can deviate from the channel frequency and still maintain intelligibility.
Operating Bandwidth	The maximum difference between the highest and lowest frequencies without retuning and still pass the specifications.
Spurious Rejection	The same as Image Rejection <u>except</u> for the unwanted signal's frequency. Spurious frequencies are all other frequencies other than the image frequencies.

Squelch Closed

Speaker audio muted.

Squelch Open

Speaker audio not muted.

Threshold Squelch

Position of the SQUELCH KNOB when noise from the speaker first disappears while knob is being turned counterclockwise.

Tight Squelch

The SQUELCH CONTROL in its fully counterclockwise position.

10 and 16-Channel Programming Reference Card

NOTE: See Programming Reference Card.

10-CHANNEL PROGRAMMING REFERENCE CARD

Programming Data Format:

AAAAAA
B
C
DD
ZZZZZZ
Enter
Chan No.

①
②
③
④
⑤
⑥
⑦

Programming Steps

1. Receiver Frequency (six digits)
 Note: For RH250UR if frequency is 7 digits subtract 2.5 KHz and enter the resulting 6-digit frequency
2. Simplex/half Duplex Code (one digit)
 Simplex: B=0 half Duplex: B=8
3. CTCSS/Transmitter Operation Code (one digit)
 C=0 for normal RX/TX operation (CTCSS - Decode/Encode)
 C=2 for normal RX/TX operation (CTCSS - Encode only)
 C=4 for transmitter disabled (CTCSS - Decode only)
4. CTCSS Tone Code (two digits)
 DD = See table at right
5. Transmitter Frequency (six digits)
 See note on 1. Only to be entered for half/Duplex operation.
6. Press ENTER
7. Press the channel number the data is to be entered in.

<u>Frequency</u>	<u>Code</u>
no tone	00
67.00 Hz	01
71.90	02
74.4	03
77.0	04
79.7	05
82.5	06
85.4	07
88.5	08
91.5	09
94.8	10
97.4	11
100.0	12
103.5	13
107.2	14
110.9	15
114.8	16
118.8	17
123.0	18
127.3	19
131.8	20
136.5	21
141.3	22
146.2	23
151.4	24
156.7	25
162.2	26
167.9	27
173.8	28
179.9	29
186.2	30
192.6	31
203.5	32
210.7	33
218.1	34
225.7	35
233.6	36
241.8	37

16-CHANNEL PROGRAMMING REFERENCE TABLE

Channel Programming Data Format: AAAAAA B C DE FY ZZZZZ Enter Chan No.
 ① ②③ ④ ⑤ ⑥ ⑦ ⑧

Channel Programming Steps

	Frequency	Code
1. Receiver Frequency (six digits) Note: For NH25160K if the frequency is seven digits subtract 2.5 KHz and enter the results	no tone 67.0 Hz 71.3 74.4 77.0 79.7 82.5 85.4 88.5 91.5 94.8 97.4 100.0 103.5 107.2 110.9 114.8 118.8 123.0 127.3 131.8 136.8 141.3 146.2 151.4 156.7 162.2 167.9 173.8 179.9 186.2 192.8 203.5 210.7 218.1 225.7 233.6 241.8	00 01 02 03 04 05 06 07 08 09 10 11 12 13 14 15 16 17 18 19 20 21 22 23 24 25 26 27 28 29 30 31 32 33 34 35 36 37
2. Simplex/half-duplex Code (one digit) Simplex: B=0 Half-Duplex: B=3		
3. Transmitter Operation Code (one digit) Normal RX/TX operation: C=0 Disable Transmitter: C=4		
4. Receiver CTCSS Tone Code (two digits) DD = see table at right		
5. Transmitter CTCSS Tone Code (two digits) YY = See table at right. Does not need to be entered if Simplex channel and tone the same as 4. Must be specified if half-Duplex is programmed.		
6. Transmitter Frequency (six digits) See note in 1. Does not need to be entered if Simplex channel.		
7. Press the ENTER button on the keyboard		
8. Press the channel number the data is to be entered into.		

Radio Configuration Data Format: T W X Enter Scan
 ① ②③ ④ ⑤

Radio Configuration Programming Steps

1. Scan Delay Code

Delay	T for A.I.C	X for UK
.68 sec	0	1
1.3 sec	2	3
2.0 sec	4	5

2. T.O.T. Code

No T.O.T.	W
30 sec	1
60 sec	2
120 sec	4

3. Key in the Decoder Interrupt Delay code from the table below:

Decoder	Delay	Code
Built-in CTCSS	0	0
External	100 ns	1
External	200	2
External	300	3
External	400	4
External	500	5
External	600	6
External	700	7
External	800	8
External	900	9

NOTE: When using external decoder consult the factory.

4. Press ENTER
 5. Press SCAN
- Channel display will display a "u"