

 **REGENCY** ELECTRONICS INC.

SERVICE MANUAL

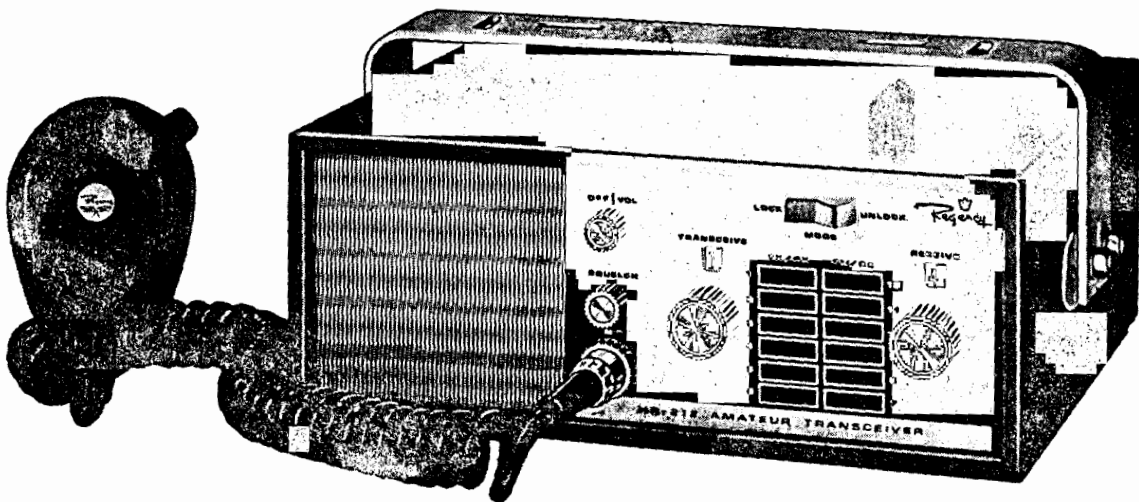

MODEL HR-212 TWO METER AMATEUR TRANSCEIVER

7707 RECORDS STREET
INDIANAPOLIS, INDIANA 46226

PRINTED IN U.S.A.

1-73

PRICE \$5.00
SM-10-357

HR-212 SERVICE MANUAL

CONTENTS

SECTION 1 GENERAL INFORMATION

- 1-1 Description
- 1-2 Specifications
- 1-3 Equipment Supplied
- 1-4 Equipment not Supplied
- 1-5 Accessories Available
- 1-6 Installation
- 1-7 Operation
- 1-8 Crystal Specifications
- 1-9 Crystal Installation
- 1-10 Crystal Jumpering

SECTION 2 CIRCUIT DESCRIPTION

- 2-1 RF-Modulator Board
- 2-2 Diode Switching Board
- 2-3 IF-Audio Board
- 2-4 Transmitter Board
- 2-5 Receiver Block Diagram
- 2-6 Transmitter Block Diagram

SECTION 3 ALIGNMENT AND TUNING PROCEDURES

- 3-1 Equipment Required-Receiver Alignment
- 3-2 Quadrature Detector Alignment
- 3-3 IF Alignment
- 3-4 RF (Receiver) Alignment
- 3-5 Quieting Sensitivity Measurement
- 3-6 Noise Balance Adjustment
- 3-7 Equipment Required-Transmitter Alignment
- 3-8 Transmitter Tuning Procedure
- 3-9 Crystal Netting Procedure
- 3-10 Deviation and Mike Gain Adjustment

SECTION 4 DIAGRAMS, VOLTAGE DATA AND SCHEMATIC

- 4-1 RF-Modulator Board Parts Placement Diagram
- 4-2 RF-Modulator Board Bottom View
- 4-3 Diode Switching Board Parts Placement Diagram
- 4-4 Diode Switching Board Bottom View
- 4-5 IF-Audio Board Parts Placement
- 4-6 IF-Audio Board Bottom View
- 4-7 Crystal Switch Board Parts Placement Diagram
- 4-8 Crystal-Switch Board Bottom View
- 4-9 Transmitter Board Parts Placement Diagram
- 4-10 Transmitter Board Bottom View
- 4-11 Transmitter Board Tune-Up Test Points

- 4-12 Voltage Data and Semiconductor Location Diagram
- 4-13 Crystal Location and Adjustment Diagram
- 4-14 Schematic (Fold Out)

SECTION 5 PARTS LIST

- 5-1 RF-Modulator Board
- 5-2 IF-Audio Board
- 5-3 Diode Switching Board
- 5-4 Crystal-Switch Board
- 5-5 Transmitter Board
- 5-6 Chassis Assembly

SECTION 1 GENERAL INFORMATION

1-1 DESCRIPTION

The Regency HR-212 is a 12 channel, all-transistor, FM transceiver designed for use in the 2 Meter (144-148 MHz) Amateur Band. The transmitter and receiver sections both employ bandpass circuitry so that maximum RF power output and receiver sensitivity are maintained across the entire band. Receive and transmit frequencies are crystal controlled, utilizing crystals manufactured within an accuracy of .001%.

The receiver and transmit channel selections may be made independently, or they may be "paired" (one Channel Selector connects both TX and Rx crystals). The Mode Switch permits a quick front panel selection of either of these two methods of channel selection. In addition, crystals may be jumpered so that they can be reused in more than one channel or position. This permits the operator to make most of his channel selections using only the Transceive Channel Selector (when in the LOCK mode). However, when he encounters an unusual paired arrangement, he can then easily switch to the independent mode (UNLOCK) and select, individually, his choice of transmit and receive frequencies.

The receive section is a double-conversion, superhetrodyne type receiver. Silicon transistors (13) are utilized for dependability under widely varying ambient conditions. Also, two Integrated Circuits are used, providing for compactness and circuit reliability. In addition, a ceramic filter is employed in the second I.F. for optimizing receiving performance where numerous channels are active within the same area of the country.

The transmitter section also utilizes silicon transistors (11) throughout. Two ruggedized RF power transistors (BET or Balanced Emitter Transistor Type) are employed for high power output, which typically is 22 watts. A large, copper heat sink on the "final" transistor ensures that there is virtually no power drop off during lengthy transmissions. In addition, an SWR bridge limiting circuit provides the necessary protection to the RF power transistors in the event the antenna or its coaxial feed line becomes open or shorted.

The transmitter employs phase modulation, utilizing two varactor diodes. Internal controls are provided for adjusting the microphone gain and for setting the amount of deviation. The deviation control is factory adjusted for approximately 7 KHz deviation (14 KHz swing).

The attenuation of spurious emissions, frequency stability and performance under highly varying supply voltage and temperature conditions all exceed FCC limits as would be required for type acceptance. (Type Acceptance of the transmitter is NOT necessary for operation in the Amateur Service.) The receiver section is Certified under Part 15, Subpart C of the FCC Rules and Regulations.

Silicon Transistors (Total).....	24
BET RF power transistors.....	2
Field Effect Transistors.....	2
Diodes (Total).....	22
Varactor Diodes.....	2
Zener Diodes.....	2
Signal Diodes.....	16
Rectifier Diodes.....	2

GENERAL

Front Panel Size.....	3 7/8" X 10 1/4"
Depth (Including knobs and rear panel connectors).....	9 1/2"
Weight (Including microphone and mounting equipment).....	5 lbs., 9oz.
Antenna Connector.....	SO-239.
Power connector.....	4-pin, polarized
Speaker size.....	3 1/2 inch, square

1-3 EQUIPMENT SUPPLIED

- a. 1-Transceiver Unit
- b. 1-Microphone and connector
- c. 1-Mobile Mounting bracket
- d. 1-Mobile mounting hardware
- e. 1-Mobile mounting Security Bracket
- f. 1-DC Power cord and fuse
- g. 1-Owner's Instruction Manual

1-4 EQUIPMENT NOT SUPPLIED

- a. 1-Antenna
- b. 1-Coaxial Cable (Feedline)
- c. 1-Coaxial cable connector
- d. 1-Power supply
- e. 1-Padlock (used with Security Bracket)

1-5 ACCESSORIES AVAILABLE

There are presently four accessories available for use with the HR-212. A DC Power Supply, the P109 meets the necessary voltage and current requirements for using the HR-212 as a base station. It is a fully regulated power supply with fuse protection in both its primary (117 VAC) and DC output connections. The mating connector for the HR-212's power plug is already installed on the power cord.

Another accessory is the AR-2, an all-transistor RF power amplifier designed for mobile use. It is a Class C amplifier capable of 80 Watts output (maximum). With an input of 22 Watts (the typical power out from the HR-212) the AR-2 will provide a power gain of approximately 5DB. Thus, the 22 watts from the HR-212 would be increased to approximately 70 watts. The only connection needed between the HR-212 and the AR-2 is the length of 50 Ω coaxial cable, such as RG-58/u. The OFF-ON switch on the AR-2 provides for normal, straight through operation (OFF) or power amplification (ON).



The third accessory is a DC Power Cord that can be plugged into a car's cigarette lighter. This accessory, Regency No. MA-10, provides for an easy or temporary mobile installation. The fourth accessory is a 4-inch speaker unit designed for remote mounting purposes. The MA-8 (the unit's accessory number) is a metal speaker enclosure with rubber feet and a metal bracket. The bracket is to be used for under-the-dash mounting or some similar application.

1-6 INSTALLATION

MOBILE (12 VDC)- The HR-212 is primarily designed for use in any car, truck, boat, etc. that has a 12 VDC negative ground system. The RED lead, with the fuseholder, must be connected to the positive (+) terminal or the battery. The BLACK lead should be connected either to the chassis or to the negative terminal of the battery.

The Mounting Bracket is designed to permit mounting the unit in a variety of positions in most vehicles. The final mounting position should be selected to allow for easy operation by the user. The bracket must be securely fastened to a solid or substantially rigid surface in order to reduce the possibility of damage due to excessive vibration.

To reduce the possibility of theft, the Security Bracket should be installed as shown in Figure 1-1. The padlock used should be of substantial construction and can be either a key or combination operated type.

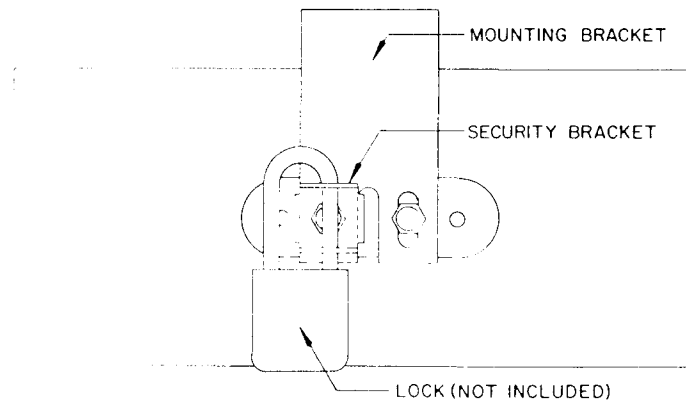

SIDE VIEW SHOWING SECURITY BRACKET INSTALLATION

FIGURE 1-1

The antenna used should be properly adjusted for the 50 ohm output impedance of the transmitter. A high SWR on the feedline (coaxial cable connecting the antenna to the unit) will reduce the power out, or may even shut off the transmitter entirely. It is recommended that an inline type wattmeter (such as a Bird ThruLine) be used for optimizing the antenna system.

If it is impossible to reduce the SWR below 1.5 to 1 and the HR-212's output is being reduced or lowered by the SWR bridge circuit, the following modification may be made. Solder a 1K, 1/4 watt resistor on the bottom side of the transmitter board, as shown in Figure 1-2. This resistor is electrically being connected between the base of Q304 and ground. This modification permits the unit to work into a load that is presenting an SWR of 2 to 1 or less, by reducing sensitivity of the SWR bridge. There will still be adequate protection for the two RF power transistors for an SWR greater than 2 to 1, or if there is an open or short in the antenna system.

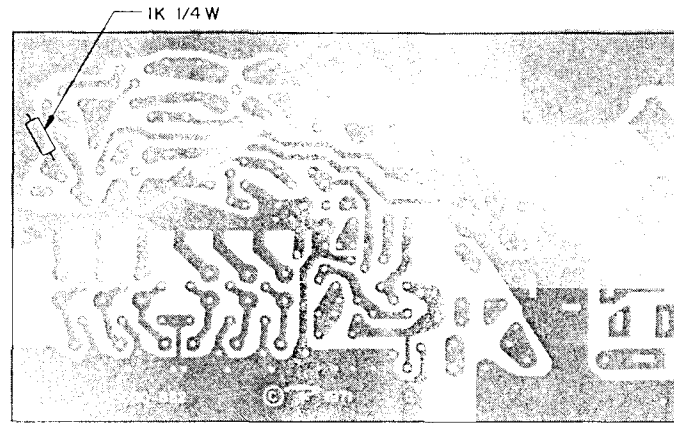

TRANSMITTER BOARD-BOTTOM VIEW

FIGURE 1-2

An external (or remotely mounted) speaker can be used by first opening the link between terminals No. 3 and No. 4. These terminals are located on the rear panel and are clearly marked on the label. Then, connect one lead of the external speaker to terminal No. 1 (chassis ground) and the other lead of terminal No.4. A 3 to 4 ohm speaker (such as Regency's Accessory No. MA-8) is recommended for optimum performance.

For a quick and easier mobile installation, an accessory 12 VDC Power Cord with a cigarette lighter plug (Regency MA-10) can be utilized. In this case, the unit can be operated on the front seat of the vehicle.

BASE STATION (117 VAC)-The HR-212 may be used with any well filtered or regulated DC power supply that can supply at least 4 amperes at 12 to 14.5 VDC. The regulation of the power supply should be such that its output voltage does not get over 14.5 VDC when the unit is in the receive mode and squelched off. Damage to various components may occur if the supply voltage to the HR-212 exceeds 15 volts for any length of time.

The power supply and/or the power connection to the unit should be properly fused. In addition, the ripple on the supply's output voltage

①

should be less than 1%. It is recommended that Regency's regulated power supply, the P109, be utilized for base station operation of the HR-212.

The antenna's impedance should be adjusted or matched, as closely as possible, for use with 50 ohm coaxial cable. Use of RG-58/u should be considered only if the length of coax needed is 30 feet or less. For longer runs of feedline, it is recommended that a low-loss cable, such as RG-8/u (especially of the "foam" type) should be used.

1-7 OPERATION

The OFF-ON switch is an integral part of the VOLUME control. Turning this control fully counter-clockwise until a click is heard will turn the unit off. The pilot or dial lamp will also visually indicate when the unit is on or off. Maximum volume, or audio output, occurs when the Volume Control is turned fully clockwise.

The receiver's audio is squelched off when the SQUELCH control is turned counter-clockwise until the noise disappears. This permits the receiver to be "quiet" until an actual signal is received. With the control set fully counter-clockwise (tight squelch), the receiver will still operate properly and will not be locked-out (prevented from responding to a proper signal). The dynamic range of the squelch control is approximately 8 or 9 db. Thus, if Threshold Squelch (control set to where the noise just disappears) is at 0.25 μv signal, tight squelch would be approximately 0.7 μv signal.

The MODE SWITCH permits the operator to select his desired method of pairing the transmit and receive frequencies. When the Mode Switch is in the LOCK position (flat side of the rocker to the left), the Transceive Channel Selector connects both the TX and RX crystals to their respective oscillator. When the Mode Switch is in the UNLOCK position (flat side of rocker to the right), the Transceive Channel Selector connects only the TX crystal to its oscillator and the Receive Channel Selector connects the RX crystal to its oscillator. Thus, the UNLOCK mode provides for completely independent transmit and receive channel selection.

The TRANSCEIVE Channel Selector is a twelve-position switch which enables the operator to select any one of the twelve crystal-controlled channels. It selects both TX and RX channels when the unit is operating in the LOCK mode. In the UNLOCK mode, it selects only the TX channel.

The RECEIVE Channel Selector is also a twelve-position switch. It is only operational when the Mode Switch is in the UNLOCK position, as indicated by its dial lamp being lighted. This Selector switch only controls the selection of RX crystals and it is not inter-connected in any way with the selection of the TX crystals.

To TRANSMIT, depress the PTT (push-to-talk) switch located on the side of the microphone. The Channel Selector must be turned to a channel that has a transmit crystal installed (or jumpered) at that position or there will be no RF power output from the transmitter section. The PTT

switch must be held in during the entire transmission in order to keep the T/R (Transmit-Receive) relay activated.

1-8 CRYSTAL SPECIFICATIONS

Due to the numerous frequencies, or channels, involved, only one pair of crystals is installed by the factory. Miniature, plug-in crystals are simply installed by inserting them in the receptacles on the circuit board. 1-9 gives thorough instructions on the actual installation. Because of the accuracy required, Shepherd Industries' crystals are recommended. They are usually available at the source from which the transceiver was purchased. Specify the exact frequency (for example, 146.340 MHz) that you desire to receive or transmit on.

If desired, the crystals may be purchased from other manufacturers. The following information should be included in the order.

RECEIVE CRYSTAL:

- a. Crystal frequency, determined as follows:

$$\text{Crystal frequency} = \frac{\text{receive frequency} - 10.7 \text{ MHz}}{3}$$

EXAMPLE:

$$\text{Crystal frequency} = \frac{146.94 \text{ MHz} - 10.7 \text{ MHz}}{3}$$

$$\text{Crystal frequency} = \frac{136.24 \text{ MHz}}{3} = 45.41333 \text{ MHz}$$

- b. Frequency Tolerance of .001%
c. 3rd overtone
d. Series resonance minus 250 Hz
e. Maximum equivalent series resistance of 35 ohms
f. Drive level of 2 MW.
g. Holder: HC-25/u

TRANSMIT CRYSTAL:

- a. Crystal frequency, determined as follows:

$$\text{Crystal frequency} = \frac{\text{transmit frequency}}{24}$$

EXAMPLE:

$$\text{Crystal frequency} = \frac{146.94 \text{ MHz}}{24} = 6.1225 \text{ MHz}$$

- b. Frequency Tolerance: .001% @ 25°C
.0015% from -10°C to +60°C
c. Fundamental mode
d. Load capacity: 32 pf
e. Maximum series resistance of 40 ohms
f. Drive level of 2MW.
g. Holder: HC-25/u

1-9 CRYSTAL INSTALLATION

Prior to installing a crystal, the transceiver will have to be partially pulled out of its cabinet. First, disconnect the microphone, antenna and power cables. Second, remove the two knobs (Volume and Squelch). Third, remove the rear panel (cover) by removing its four mounting screws. Fourth, remove the four rubber feet by carefully unscrewing each one. The transceiver may then be slid rearward from the cabinet until the crystal socket pins are accessible. As the unit is slid rearward, it will be necessary to slightly move it from side to side in order for the heat sink screws to clear the side lips of the cabinet.

Insert the crystal in the proper socket pins as indicated on the Crystal Location Drawing, 4-13. Facing the front of the unit, the RECEIVE crystals are installed in the group of sockets located near the left side of the unit. The TRANSMIT crystals are installed in the group of sockets located near the rear edge and on the vertical PC board that holds the transmit channel selector switch. The unit is shipped from the factory with transmit and receive crystals for 146.94 MHz installed in Channel 1.

For each transmit crystal, there is a variable capacitor that is to be used for "netting" (adjusting to the exact frequency) purposes. This netting or frequency adjustment should be made with an accurate frequency counter. See 3-9 for detailed netting instructions.

If any of the crystals are to be jumpered (re-used in other channels) it will be necessary to completely pull the unit out of its cabinet. See section 1-10 on Crystal Jumpering. If jumpering is not required, carefully slide the unit back into the cabinet. Screw the four feet back into place and replace the rear panel. Push the Volume and Squelch knobs back on their shafts. Reconnect the microphone, power and antenna cables and the unit is again ready for operation.

The frequency, or channel, blocks on the front panel will accept 1/4 inch wide embossing tape with up to five digits, letters, or other characters. These blocks are to be used to identify the particular frequencies installed in the unit.

1-10 CRYSTAL JUMPERING

In order to reduce the total number of crystals required, it is possible, and highly desirable, to use a crystal in more than one position (channel) if that specific frequency is used again. For example, 146.76 MHz, as a receive frequency, is used in several normal paired arrangements. Thus, by means of jumpering, only one crystal is actually required to be installed in order for the operator to have that frequency available in more than one channel. Detailed jumpering instructions will be given first and then an example will be worked out that illustrates the jumpering procedure.

To re-use a RECEIVE crystal, solder a capacitor, as supplied, from the channel that the desired crystal is installed in to the one that

you want to also receive the same frequency. See the illustration on page 10. Use the short lengths of insulation as shown in the illustration in order to prevent shorting out other receive channels.

To re-use a TRANSMIT crystal, a short insulated jumper is soldered from the desired position on the copper side of the transmit switch deck to the position that connects the crystal as installed. The illustration on page 11 clearly shows how a jumper is to be positioned and soldered.

Jumpering Example:

An example of some typical transmit-receive combinations, utilizing a minimum number of crystals, will be demonstrated. Suppose the following TRANSMIT-RECEIVE combinations are to set up in your HR-212:

<u>Channel Selector (Transceiver) Position</u>	<u>Transmit Frequency (MHz)</u>	<u>Receive Frequency (MHz)</u>
1	146.94	146.94
2	146.16	146.76
3	146.22	146.82
4	146.28	146.88
5	146.34	146.76
6	146.34	146.94

Install the proper transmit and receive crystals in the appropriate crystal positions as indicated below. See the Crystal Location and Adjustment Diagram, 4-13.

<u>Transmit Crystal</u>	<u>Initial Position</u>	<u>Receive Crystal</u>	<u>Initial Position</u>
146.94	1	146.94	1
146.16	2	146.76	2
146.22	3	146.82	3
146.28	4	146.88	4
146.34	5		

To easily determine where jumpers are to be installed, add to the crystal's Initial Position all of the other positions desired. Thus, to continue on with the example, the following table would be compiled:

<u>Transmit Crystals</u>	<u>Total Positions</u>	<u>Receive Crystals</u>	<u>Total Positions</u>
146.94	1	146.94	1-6
146.16	2	146.76	2-5
146.22	3	146.82	3
146.28	4	146.88	4
146.34	5-6		

As can readily be seen in the preceding table, only one Transmit position and two Receive positions have to be jumpered.



NOTE: It is recommended that no more than three additional positions be jumpered to the original (Initial) crystal position. Also, the jumpering should be worked out so as to keep the continuous jumper length to a minimum.

To jumper the two Receive crystals, solder two capacitors (.001 mfd) as shown in Figure 1-3 below. Be sure to use the short lengths of insulation on the capacitors' leads.

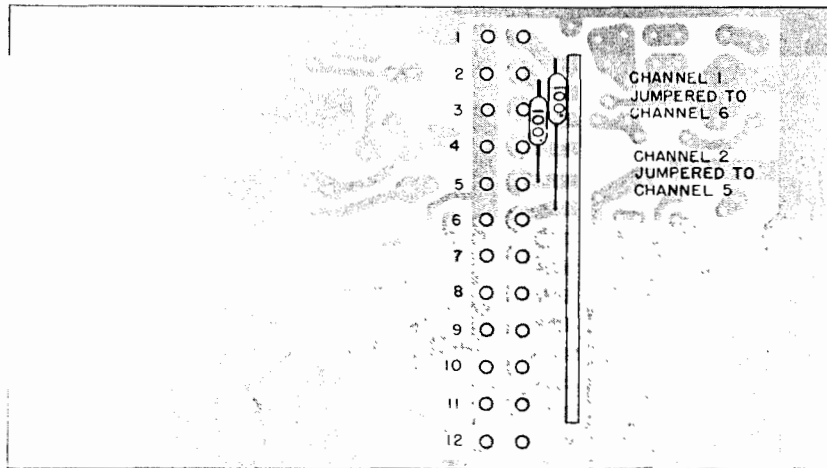

RF BOARD - BOTTOM VIEW

FIGURE 1-3

Connect the following jumper on the copper side of the TRANSMIT switch deck (No. 500-889) as illustrated in Figure 1-4 on page 11: Position 5 to Position 6. For jumpers that are not connecting adjacent positions, it is recommended that insulated No. 22 or 24 guage wire should be used to avoid a possible short circuit. In some cases, it would be easier to add jumpers if the TX crystals are not actually installed until all of the TX jumpers are soldered in place.

NOTE: Adding a jumper will slightly lower the Transmit crystal frequency. Adjust the associated trimmer capacitor on the transmitter board for correction.

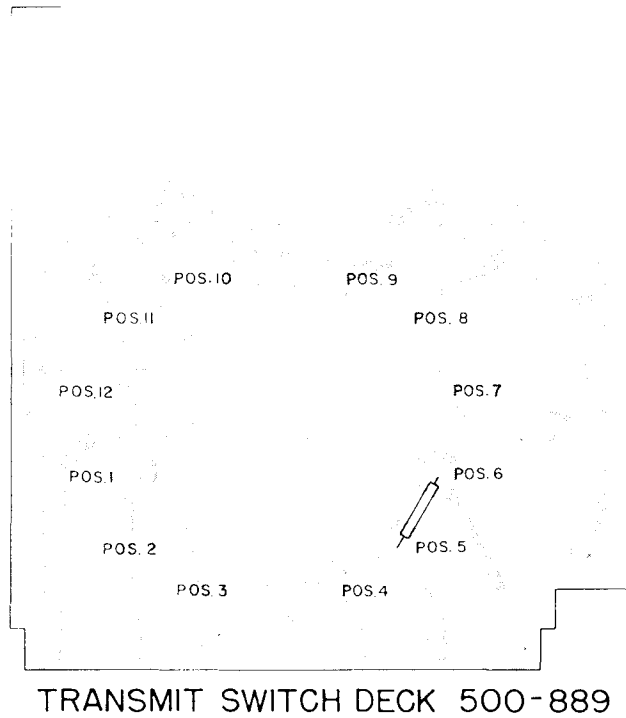

FIGURE 1-4

This illustration was shown to demonstrate the extreme versatility incorporated in your HR-212. With the example worked out above, your HR-212 would be capable of working more than 310 of the single band 2 meter FM repeaters, as listed in a recently published directory. Only three additional Receive crystal and four Transmit crystals are required plus, of course, the necessary jumpers. It should be noted that NO jumpers are required if the operator desires to make his paired arrangements solely by means of the two front panel Channel Selectors (in the UNLOCK mode). However, for quicker channel selection and to help ensure that you are working the TX-RX frequencies that you think you are, it is recommended that jumpering be utilized, whenever possible, for the normal paired frequencies.



SECTION 2 CIRCUIT DESCRIPTION

2-1 RF-MODULATOR BOARD

Q201 is an RF amplifier with broad-band tuned circuits in its input and output circuitry. The output of the RF amplifier is coupled to the input of the mixer, Q202, a Field Effect transistor.

The first L.O. (local oscillator), Q204, uses third overtone crystals. (The frequency marked on the crystal is the receive frequency). Oscillator injection to the mixer is accomplished by mutual coupling between the windings of T201.

The output frequency from the FET mixer is tuned to 10.7 MHz by T202. This output is link-coupled to T101, the IF input tuned circuit.

The Modulator section of this board is described in 2-3 in conjunction with the transmitter board.

2-2 DIODE SWITCHING BOARD

An RX crystal is electrically connected to the oscillator circuit when its associated diode is forward biased. The Channel Selector switch applies a ground to the appropriate RF choke (L501 through L512), which places forward bias on the diode. The chokes in conjunction with the resistors (R513 through R524) provide the necessary isolation between the crystals not being selected. The Mode Switch determines which Channel Selector actually applies the ground connection.

2-3 IF-AUDIO BOARD

The IF input circuitry consists of T101 and Q101, used as an IF amplifier. The output of this amplifier is fed to an integrated circuit, IC101, which contains another amplifier for 10.7 MHz, the second mixer circuitry and the second L.O. circuitry, operating at 10.245 MHz. In some locations where a strong Image signal has been encountered, this oscillator's frequency is moved to 11.155 MHz. (The crystal frequency is stamped on the top of the crystal.)

The 455 KHz output of IC101 (terminal 5) is coupled through a tuned circuit to the input of the ceramic filter, CF-1. CF-1 is a narrow-band filter centered at 455 KHz. The excellent band-pass characteristics of CF-1 provide for very good adjacent channel rejection. The output of CF-1 is coupled through another tuned circuit to the input of integrated circuit IC102. IC102 is a series of amplifiers providing approximately 60 DB gain at 455 KHz. Also included in IC102 is the limiting circuitry and a quadrature detector circuit. L103, connected between terminals 2 and 12 of IC102, is the adjustable quadrature coil.

The audio output from IC102 (terminal 1) is coupled to the input of the audio amplifier circuit and to the input of the noise-operated squelch circuit.

Transistor Q102 is an amplifier whose frequency response extends from approximately 5 KHz to 25 KHz. Q102 amplifies the "noise" occurring in this frequency range. The noise is coupled to the base of Q103. Q103 is used as a detector which rectifies the amplified noise and produces a DC voltage at its collector. When the DC voltage at the collector of Q103 is positive and of sufficient value to provide base bias for Q104, Q104 turns on and provides essentially a short circuit between the base of Q105 and ground. This action turns off Q105 and the audio output from the receiver is squelched (muted). When a signal (carrier) arrives, the noise input to the detector (Q103) is reduced to the point where the DC voltage at the base of Q104 is no longer sufficient to cause Q104 to conduct.

At this time, Q105 is allowed to conduct normally and the audio output of the unit is heard. With the audio pre-amplifier (Q105) operating normally, audio is applied through the volume control to the base of the audio amplifier, Q106. Q106 supplies a signal to the audio driver transistors, Q107 and Q108. The output transistors, Q109 and Q110, form a quasi-complementary, transformerless stage capable of delivering 5 watts to the speaker.

2-4 TRANSMITTER BOARD

Q308 is in a crystal circuit operating at approximately 6 MHz. Each crystal has a trimmer capacitor in series with it. This trimmer capacitor is used for fine (small) adjustments to the crystal's frequency.

The oscillator's frequency is phase modulated by two Varactor (Voltage-variable capacitance) diodes, CR302 and CR303, which are connected across a coil (L305) that is lightly coupled to the emitter circuit of the oscillator. L305 is tuned to the crystal frequency. The oscillator's phase-modulated output is applied to the base of Q307. Q307 is a multiplier whose output frequency is four (4) times the crystal frequency. The signal from Q307 is transformer coupled to the base of Q306. Q306 is used as a tripler, a stage that multiplies its input signal's frequency by three. Thus, the output frequency of Q306 is twelve (12) times the crystal frequency. This signal is then applied to Q303, which is operating as a doubler. The frequency of the output signal from Q303 is twenty-four (24) times the crystal frequency. This frequency is the ultimate transmitter output frequency.

Q302 and Q301 are power amplifiers operating "straight through". Q302 provides the drive (RF signal) required by the "final" stage, Q301, to deliver at least 20 watts of RF power to the antenna through the impedance matching network in its collector circuit. Q301, Q302 and Q303 operate in the Class C Mode.

The transmitter output transistor, Q301, is protected from damage due to excessive SWR on the antenna transmission line by SWR Bridge and Drive Limiter circuits. In the event of a load mismatch at the antenna terminals, the SWR Bridge consisting of T301, R301, R305 and CR301 detects the mismatch and sends a signal to the Drive Limiter circuitry. The first stage (Q304) of the Drive Limiter circuitry provides a control-

ling voltage (base bias) for the second Drive Limiter stage (Q305). Q305 is in the emitter circuit of Q306 and controls the gain of this stage. When the mismatch (high SWR) is detected, Q304 will bias Q305 to an unsaturated condition, which in turn will reduce the gain of Q306. As Q306's gain is reduced, less RF drive is delivered to the final power amplifier stage (Q301). With less RF drive (or no drive in case of a severe mismatch), Q301's power output is reduced to a level that will prevent possible damage to this stage.

The modulator section of the transmitter uses a high impedance ceramic microphone. The microphone signal is applied to a Field Effect transistor, Q205. The output of Q205 is applied through the microphone gain control (R217) to Q206. The mike gain control is adjusted to compensate for the output differences of various microphones and for differences in the voice levels of various operators and will normally be set at about 75% of maximum clockwise rotation. This control sets the mike signal to the proper clipping level for the logarithmic clipper diode circuitry between stages Q206 and Q207. Suitable pre-emphasis and de-emphasis is used preceding the following the diode clippers. The deviation control (R228) in the collector circuit of Q207 sets the level of the audio signal voltage applied to the Varactor diode modulator circuit. This level is adjusted for a maximum of 15 KHz deviation with the clippers driven to full clip by a 1 KHz audio signal. As shipped from the factory, the deviation is set for approximately 7 KHz.

The push-to-talk (PTT) switch in the microphone applies a ground to the transmit-receive relay coil, which activates the relay. The T-R relay switches the supply voltage between the receiver and transmitter. It also switches the antenna between the receiver and the transmitter.

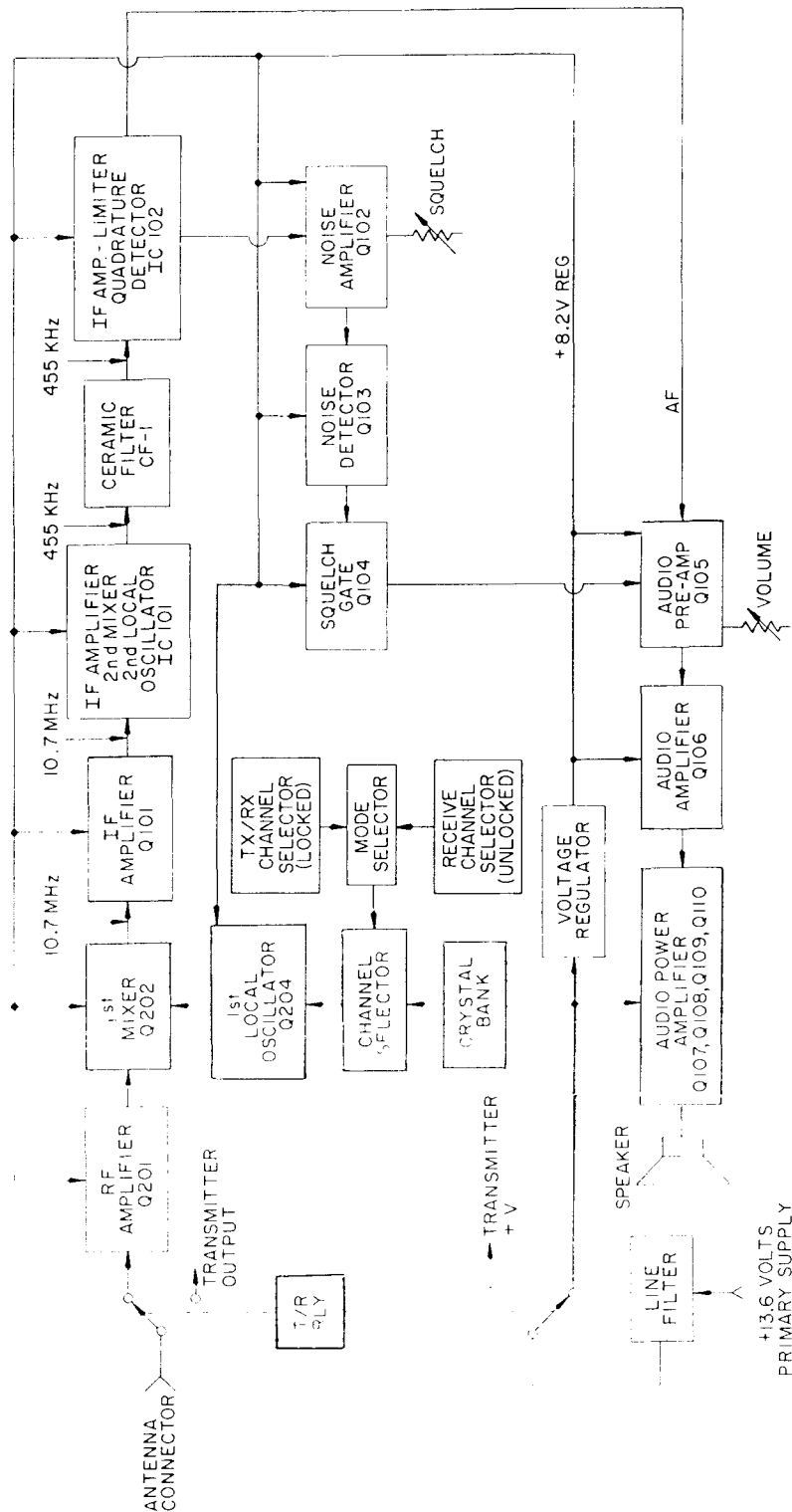

2-5 RECEIVER BLOCK DIAGRAM

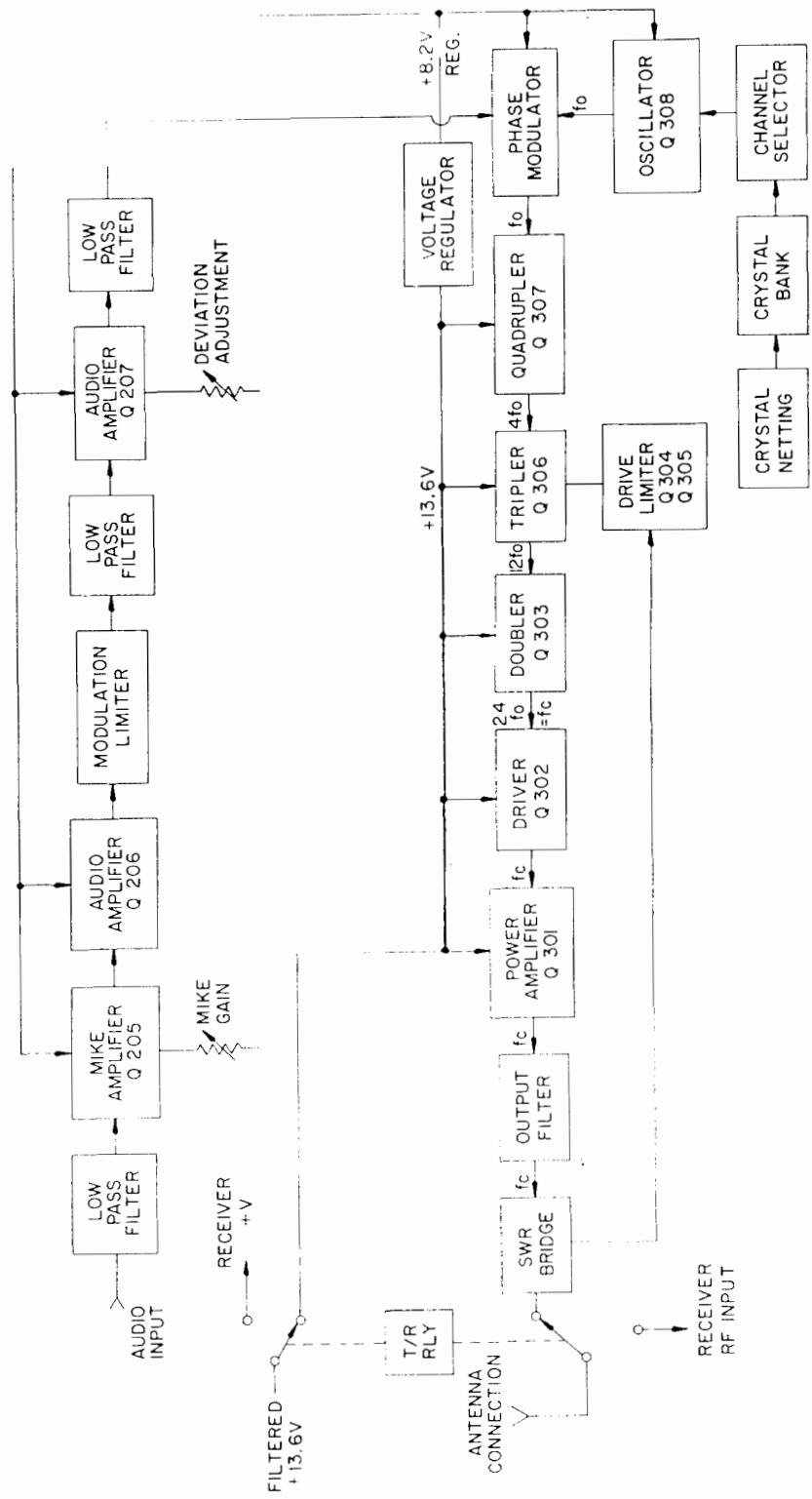

2-6 TRANSMITTER BLOCK DIAGRAM

2

SECTION 3 ALIGNMENT AND TUNING PROCEDURES

3-1 EQUIPMENT REQUIRED - RECEIVER ALIGNMENT

- 3-1-1 FM Signal Generator
- 3-1-2 Oscilloscope
- 3-1-3 AC VTVM
- 3-1-4 Noise Generator (to be used in 3-6 only)

NOTE: During all steps of alignment, the squelch control should be in the maximum clockwise position (minimum squelch action).

All transceivers should be aligned to the channel nearest the center of the frequency range over which they will operate.

Diagrams 4-1 and 4-5 show the location of all coils to be adjusted.

3-2 QUADRATURE DETECTOR ALIGNMENT

- 3-2-1 Connect the FM Signal generator to the antenna input jack. Accurately set frequency to the center of the channel being used for alignment. Modulate signal generator with 1000 Hz, 3 KHz deviation.
- 3-2-2 Connect the oscilloscope to test point A, (Junction of C126, C128, R113). See diagram 4-6.
- 3-2-3 Adjust output of signal generator until all noise in scope pattern just disappears.
- 3-2-4 Adjust L103 for maximum peak to peak amplitude, while maintaining symmetry of detected signal.

3-3 IF ALIGNMENT

- 3-3-1 Disconnect RF signal generator from antenna input.
- 3-3-2 Connect AC voltmeter across speaker terminals.
- 3-3-3 Adjust volume control for 0.5 volt noise reading on AC voltmeter.
- 3-3-4 Peak T102 (bottom core and top core, in that order) for maximum noise (maximum meter reading on AC voltmeter). If circuit is not badly misaligned, the correct point should be within 2 turns of the cores' present position.

NOTE: Coils will have two peaks; adjust core to peak away from the center of the coil form.

- 3-3-5 Adjust volume control for 1.0 volt noise reading on AC voltmeter.
- 3-3-6 Connect the R.F. signal generator to the antenna input jack. Turn the modulation off. Set the generator to the operating crystal frequency.

3

- 3-3-7 Adjust the signal generator output until the voltmeter reads 0.2 volts.
- 3-3-8 Adjust T101, T202, T201 (bottom core) and T201 (top core), (in that order), for maximum quieting (lowest meter reading). Adjust signal generator to maintain reading on AC voltmeter between 0.1 and 0.2 volts. If two peaks occur, use the one away from the center of the coil form.
- 3-3-9 Set the generator frequency to the secondary image frequency. This is 910 KHz BELOW the channel frequency.

NOTE: Some receivers may have the second oscillator at 11.155 MHz, if this is the case, the image frequency is 910 KHz ABOVE the channel frequency. Check the frequency marked on top of the crystal (10.245 MHz for below and 11.155 MHz for above).

- 3-3-10 Adjust the signal generator output until voltmeter reads .2 volts.
- 3-3-11 Adjust T102 (bottom core), T102 (top core), T101 and T202 (in that order) for maximum quieting degradation (highest meter reading). Adjust signal generator output to maintain voltmeter reading between 0.1 and 0.2 volts. The correct position for the cores should be within two turns of the position in step No. 4 and 8.

3-4 RF (RECEIVER) ALIGNMENT

- 3-4-1 Pre-set the cores of L201, L202, L203 flush with the tops of the coil forms.
- 3-4-2 Connect AC voltmeter across the speaker terminals.
- 3-4-3 With nothing connected to the antenna input, adjust the volume control until AC voltmeter reads 1 volt of noise.
- 3-4-4 Connect signal generator to antenna input jack. Set generator accurately to the center frequency of the channel being used for alignment. Turn modulation off.
- 3-4-5 Adjust output of signal generator until AC voltmeter reads .2 volts.
- 3-4-6 Adjust L201, L202 and L203, in that order, for maximum quieting (lowest meter reading). Adjust signal generator output to maintain voltmeter reading between .1 and .2 volts. Repeat adjustments until no further improvement can be made. If two peaks occur on any core, use the peak with the core nearest the top of the coil form.
- 3-4-7 Adjust T102 (bottom core) and T201 (top core), in that order, for maximum quieting (lowest meter reading). Adjust signal generator to maintain reading on AC voltmeter between .1 and .2 volts. If two peaks occur, use the one away from center of the coil form.

3-5 QUIETING SENSITIVITY MEASUREMENT

- 3-5-1 Connect the AC voltmeter across the speaker terminals.
- 3-5-2 Adjust the VOLUME control for a 1 volt noise reading on the AC voltmeter.

- 3-5-3 Connect the FM signal generator to the antenna connector. Accurately set the generator's frequency to the receive frequency being used for alignment purposes. Do NOT modulate the generator's signal.
- 3-5-4 Adjust the output of the signal generator until the noise reading on the AC voltmeter decreases by 20DB. (0.1 volt reading if the original reading was 1 volt). The setting on the generator's output control (or dial) indicates the unit's sensitivity for 20DB of noise quieting.

3-6 NOISE BALANCE ADJUSTMENT

NOTE: This adjustment may be required only if excessive "ignition noise" is encountered. Usually, the "noise" problem is caused by improper or inadequate noise suppression of the vehicle's ignition system.

- 3-6-1 Using a "T" connector, connect the FM signal generator and the Noise Generator to the antenna input jack. If a "T" connector is not available, connect the FM generator to the antenna jack and feed in the noise signal by means of a 3 or 4 turn loop coupled to the input coil, L201.
- 3-6-2 Connect the oscilloscope to the junction of Q109's emitter and Q110's collector, or to the speaker terminals.
- 3-6-3 Apply a 3 to 10 microvolt signal, as accurately as can be set to the exact channel frequency (carrier only, no modulation), and adjust the the output of the noise generator until spikes are clearly seen in the audio output as viewed on the oscilloscope. The noise spikes will be either mostly positive or negative if an unbalanced condition exists.
- 3-6-4 Tune L103 (quadrature detector coil) until the noise spikes are equally positive and negative in their amplitude. The overall amplitude of these spikes should be much less as a balance is achieved. Usually, only a 1/4 turn, or less, is needed to obtain the proper adjustment for best noise balance. If a proper balance can not be achieved, repeat the IF and RF alignments and then try the noise balance adjustment again.

3-7 EQUIPMENT REQUIRED - TRANSMITTER ALIGNMENT

- 3-7-1 RF Wattmeter (or any equivalent device which provides a 50 ohm load at the appropriate power range).
- 3-7-2 Frequency Counter-150 MHz preferred; 50 MHz acceptable.
- 3-7-3 FM Modulation Meter-Lampkin 205A or equivalent peak reading deviation meter.
- 3-7-4 Audio generator-HP 200D or equivalent.
- 3-7-5 VTVM
- 3-7-6 Oscilloscope

3-8 TRANSMITTER TUNING PROCEDURE

NOTE: The encircled numbers on diagram 4-11 correspond to the last digit in the following procedure steps. The unit must be connected to a suitable 50Ω load for proper alignment of the final transmitter stage.

- 3-8-1 Install crystals. For full bandwidth alignment, use crystals that cover each end of the band and also one whose frequency is near the center of the band. Alignment is done on the center frequency and then the bandwidth is checked using the high and low limit crystals.
- 3-8-2 Tighten trimmer capacitors C302 and C303.
- 3-8-3 Set the "netting" capacitor (12 trimmers; see also diagram 4-13) to mid-range.
- 3-8-4 With the transmitter keyed and the center frequency crystal operating, voltage at this point should be 2.5 to 3.0 Volts as read on a VTVM.
- 3-8-5 Move the VTVM's probe to this point and adjust L305 for a maximum reading (1.8 to 2.0 Volts).
- 3-8-6 Move the VTVM's probe to this point. Alternately peak the upper and lower cores of T305 for a maximum reading (normally 1.5 to 2.0 Volts). Check this reading at the lowest and highest crystal frequencies installed for proper bandpass alignment.

Repeat steps 3-8-5 and 3-8-6 until no further improvement can be made. After these adjustments have been made, L305 and the primary (bottom core) of T305 should not be changed during the remainder of the alignment procedure.

NOTE: The frequency of the oscillator will change slightly whenever L305 and T305 are adjusted. Therefore if the adjustment of these parts is ever changed, it is important to perform the Crystal Netting Procedure, 3-9.

- 3-8-7 Move the VTVM's probe to this point. Alternately peak the upper and lower cores of T304 for a maximum reading (0.4 to 0.6 Volts) at this point.
- 3-8-8 T303: Set the bottom core (primary) so that the top edge is midway between the top of the coil collar and the bottom winding. Key the transmitter and adjust the top core (secondary) for maximum power output on the wattmeter. During Power Amplifier alignment, the secondary of T303 and, if necessary, the primary are retouched for maximum power.

NOTE: If the Power Amplifier Stage (Q301) is detuned to the extent that no power indication can be obtained, the following procedure can be used to set the cores of T303 near their correct position: Move the VTVM's probe to Test Point 8. Starting with the top core of T303, alternately adjust both cores for a MINIMUM voltage at this point. Now proceed with 3-8-9 and the rest of the Tuning Procedure. With the transmitter delivering rated output power, the voltage drop across R329 will normally be 1.0 to 1.5V.

3-8-9 Set the core of T302 to the center of the coil winding.

3-8-10 Power Amplifier Alignment

- a. Set C302 almost tight.
- b. The following adjustments are peaked in the order listed for maximum power output as indicated on the R.F. wattmeter.
 - 1.) Peak C303
 - 2.) Peak C308
 - 3.) Peak C302
 - 4.) Repeat the above three steps until no further improvement is noted.
 - 5.) Repeak T303 as in 3-8-8 above.
- c. Check bandwidth with low and high frequency crystals. Adjust T303 for best output compromise between high and low limits. Adjusting the core of T302 will sometimes help widen the bandwidth. C308 is the final adjustment for best compromise over frequency range.

3-9 CRYSTAL NETTING PROCEDURE

- 3-9-1 Use the following procedure if a 150 MHz Counter is available;
- a. Connect the unit to the RF Wattmeter of dummy load.
 - b. Turn transmitter on (key the mike's PTT switch or insert a shorting plug into J2).
 - c. Place an RF pick-up loop consisting of 3 or 4 turns near the final transistor's output circuit (near L301; see diagram 4-9).
 - d. Read the frequency on the counter.
 - e. Adjust the appropriate netting capacitor (see diagram 4-13 for their location) until the frequency being read on the counter is "on" channel. (Or at least to within 200 Hertz of the desired frequency.)
- 3-9-2 Use the following procedure if only a 50 MHz counter is available:
- a. Connect the unit to the RF Wattmeter or dummy load.
 - b. Turn transmitter on.
 - c. Place an RF pick-up loop near the top of coil T-305.

NOTE: Due to a possible slight "pulling" of the crystal's frequency, couple the pick-up loop as lightly as possible to T-305. Excessive coupling to the bottom coil will prevent a proper crystal netting adjustment from being made. Use the maximum sensitivity available at the counter's input.

- d. Multiply the frequency read on the counter by six (6) to find the ultimate frequency being transmitted.

EXAMPLE: Frequency read = 24.360000 MHz

Ultimate Frequency = $6 \times 24.36000 = 146.16$ MHz

- e. Adjust the appropriate netting capacitor until the frequency being read is within the required tolerance at one-sixth ($1/6$) of the

ultimate transmitted frequency. It is recommended that the crystal be netted to within 30 Hertz of the required one-sixth frequency.

EXAMPLE: Ultimate Frequency = 146.16 MHz

Counter Reading = $\frac{146.16 \text{ MHz}}{6} = 24.360000 \text{ MHz}$

3-10 DEVIATION AND MIKE GAIN ADJUSTMENT

- 3-10-1 Use the following procedure for proper adjustment of the mike gain (R217) and Deviation (R228) controls (see diagram 4-13 for their location):
- a. Connect the unit to the RF Wattmeter or dummy load.
 - b. Connect the scope probe to the junction of C225 and CR201. See 4-1 for location. It may be more convenient to connect the probe to the cathode lead of CR202.
 - c. Key the transmitter and talk into the microphone with a normal voice level. Observe the waveform on the scope and adjust R217 (Mike Gain) until approximately 10% of the voice peaks are clipped.
 - d. Connect the audio generator to the mike input terminals. Set the audio voltage level to 0.5-1.0 volts RMS at 1000 Hz.
 - e. Couple the FM Modulation Meter's RF pick up to the transmitter.
 - f. Key the transmitter and adjust R228 (Deviation Control) so that the maximum deviation is no greater than 15 KHz (or whatever lesser value is desired).
 - g. Reduce the audio input level to 0.25 Volts RMS. The deviation should not be greater than the value adjusted for in the previous step.

SECTION 4 DIAGRAMS, VOLTAGE DATA AND SCHEMATIC

4-1 RF - MODULATOR BOARD PARTS PLACEMENT DIAGRAM

4-2 RF - MODULATOR BOARD BOTTOM VIEW

4-3 DIODE SWITCHING BOARD PARTS PLACEMENT DIAGRAM

4-4 DIODE SWITCHING BOARD BOTTOM VIEW

4-5 IF-AUDIO BOARD PARTS PLACEMENT DIAGRAM

4-6 IF-AUDIO BOARD BOTTOM VIEW

4-7 CRYSTAL-SWITCH BOARD PARTS PLACEMENT DIAGRAM

4-8 CRYSTAL-SWITCH BOARD BOTTOM VIEW

4-9 TRANSMITTER BOARD PARTS PLACEMENT DIAGRAM

4-10 TRANSMITTER BOARD BOTTOM VIEW

4-11 TRANSMITTER BOARD TUNE-UP TEST POINTS

4-12 VOLTAGE DATA AND SEMICONDUCTOR LOCATION DIAGRAM

4-13 CRYSTAL LOCATION AND ADJUSTMENT DIAGRAM

4-14 SCHEMATIC DIAGRAM

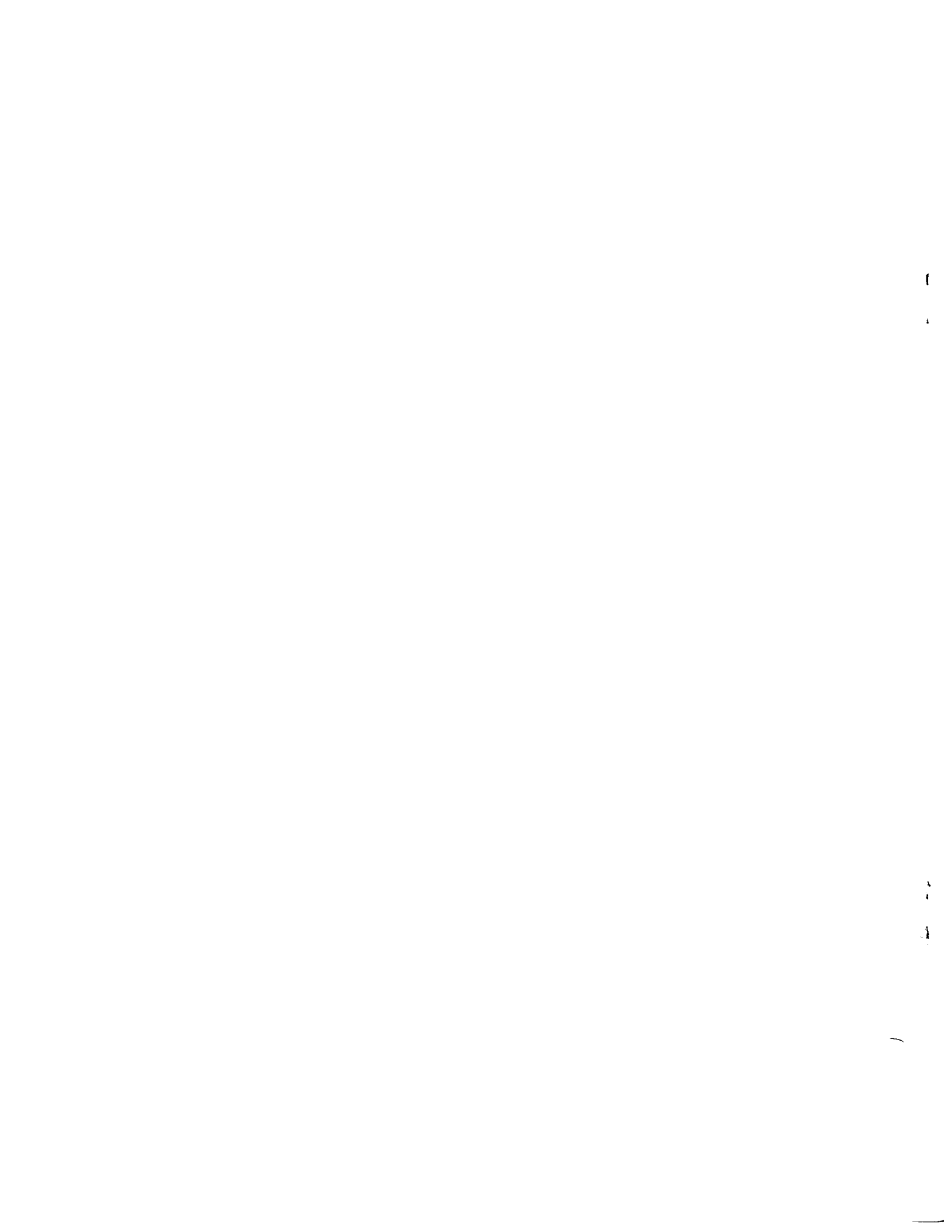

RF BOARD 500-861

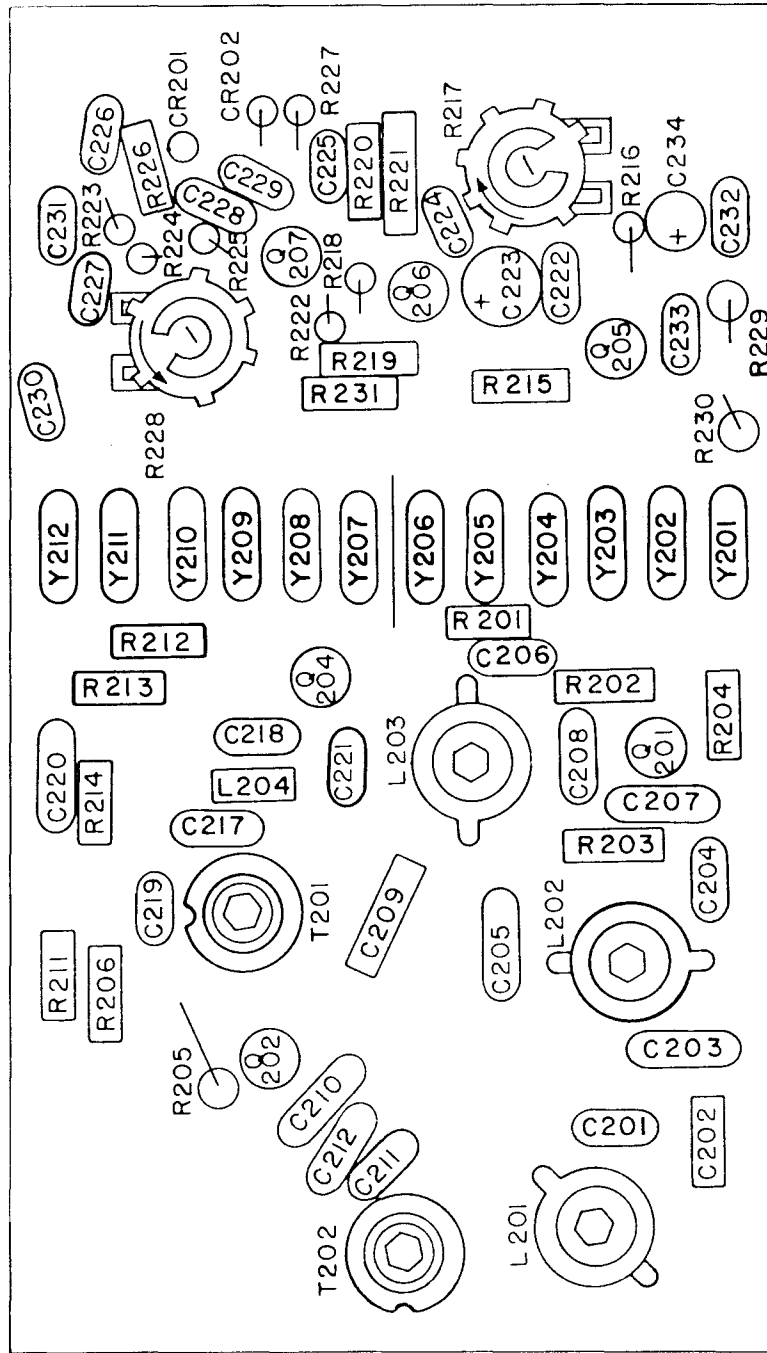

4-1 RF - MODULATOR BOARD PARTS PLACEMENT DIAGRAM

RF BOARD 500-861

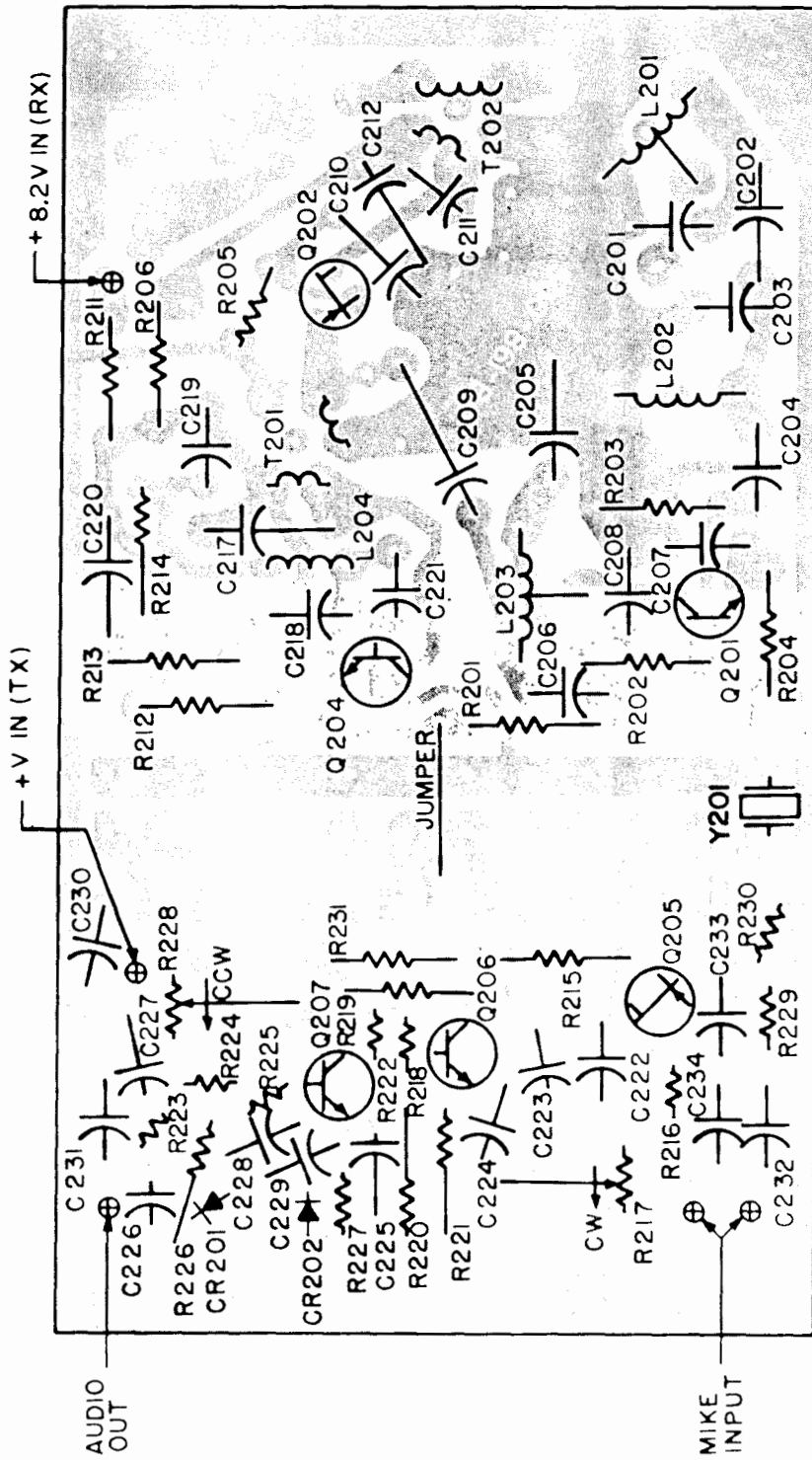

4-2 RF - MODULATOR BOARD BOTTOM VIEW

DIODE SWITCHING BOARD 500-887

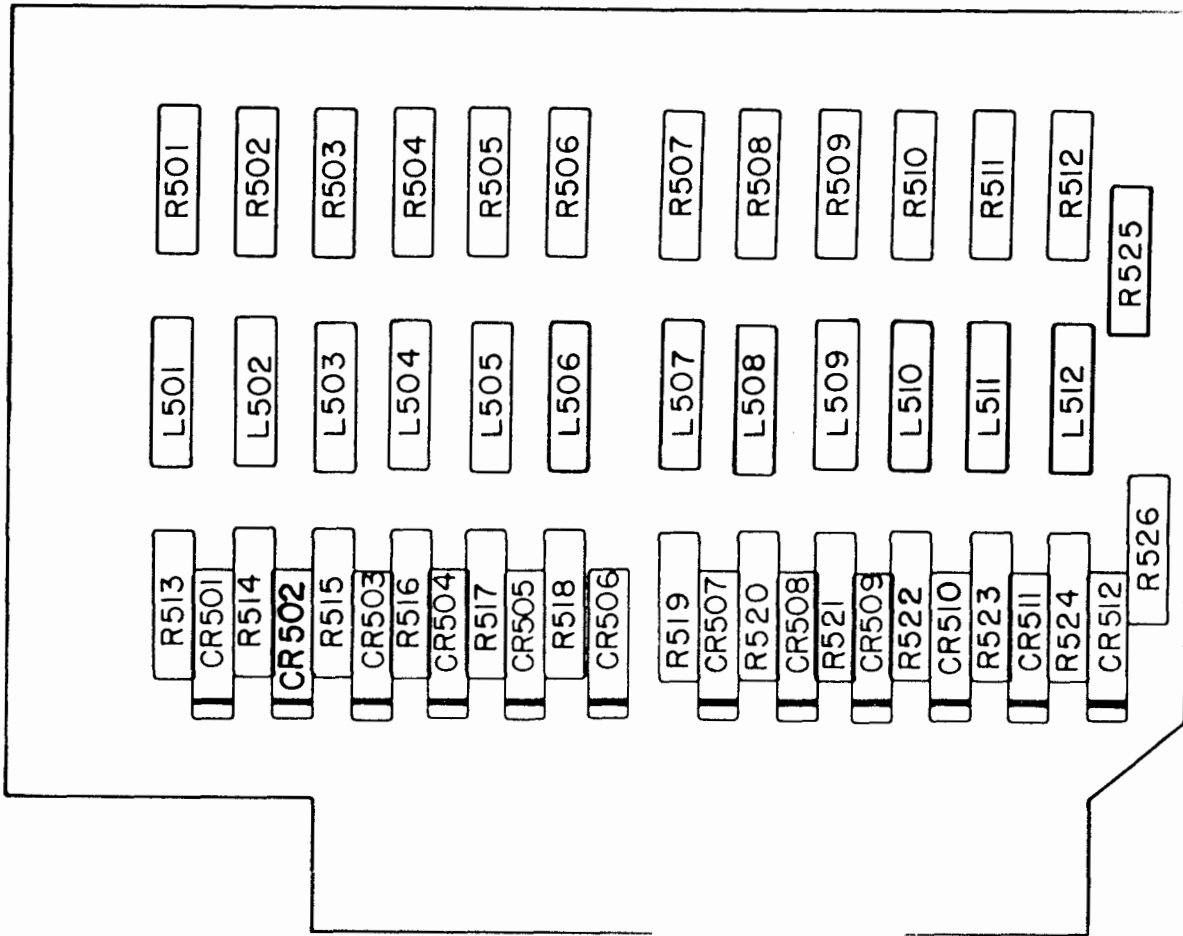

4-3 DIODE SWITCHING BOARD PARTS PLACEMENT DIAGRAM

DIODE SWITCHING BOARD 500-887

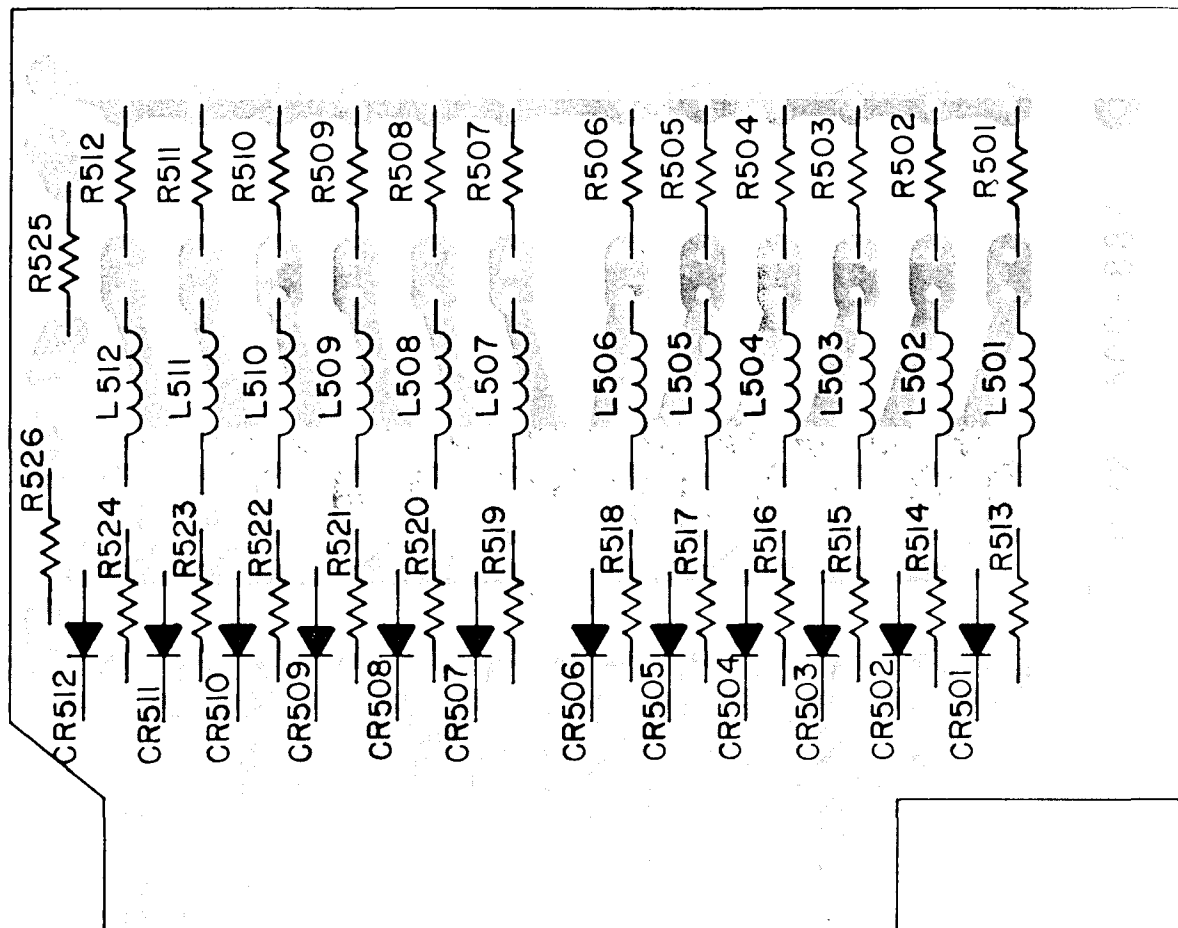

4-4 DIODE SWITCHING BOARD BOTTOM VIEW

4

IF BOARD 500-858

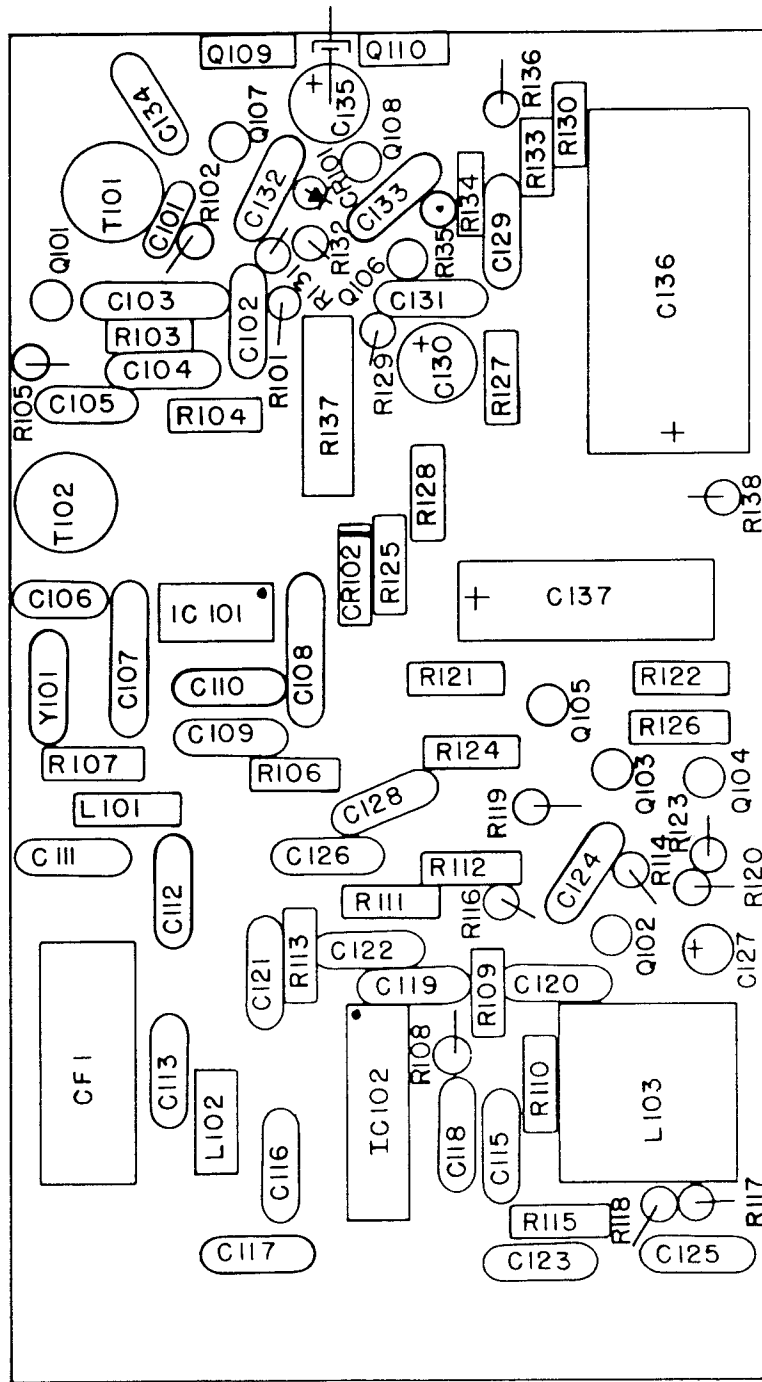

4-5 IF-AUDIO BOARD PARTS PLACEMENT DIAGRAM

IF BOARD 500-858

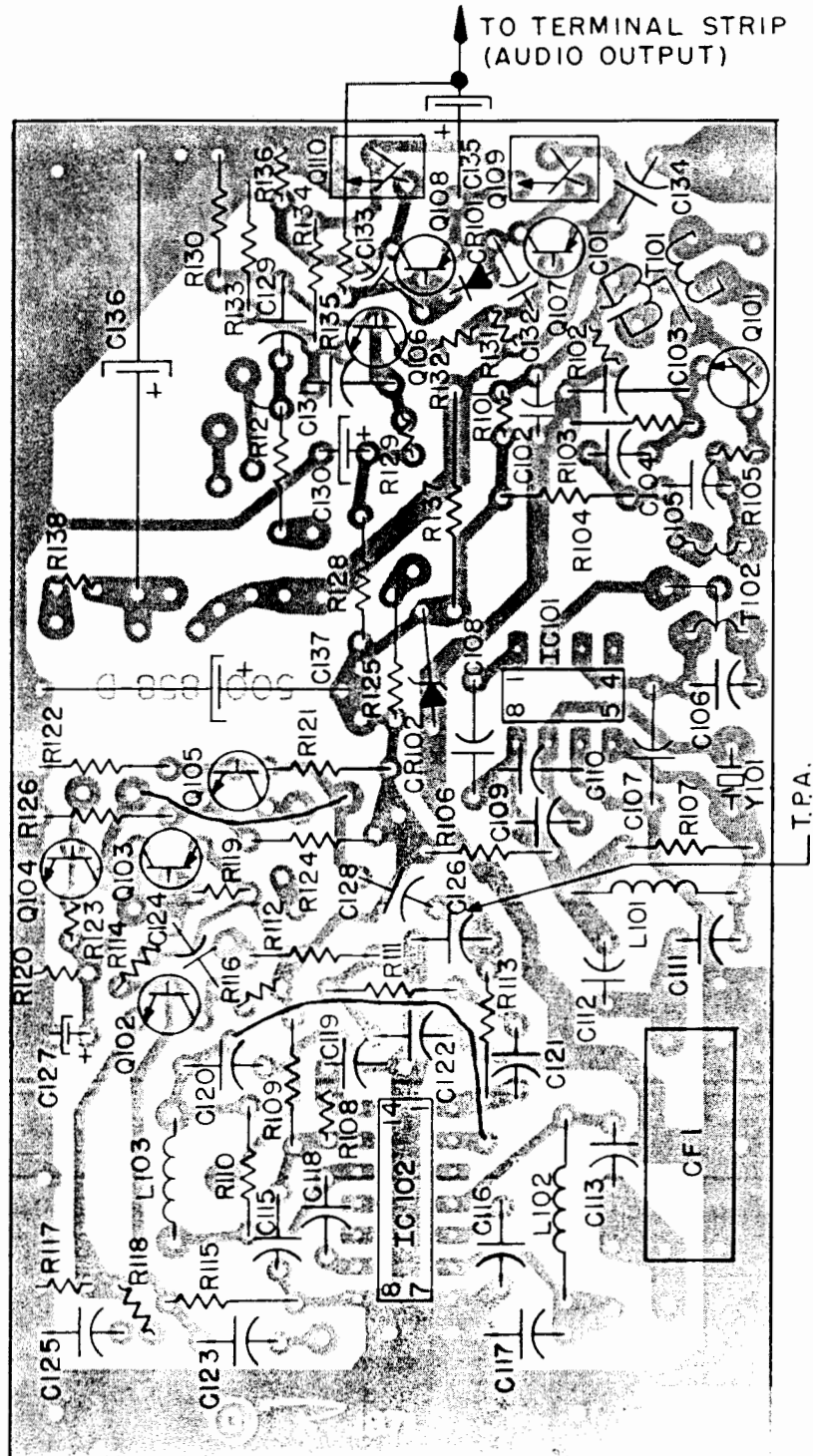

4-6 IF-AUDIO BOARD BOTTOM VIEW

CRYSTAL-SWITCH BOARD 500-889

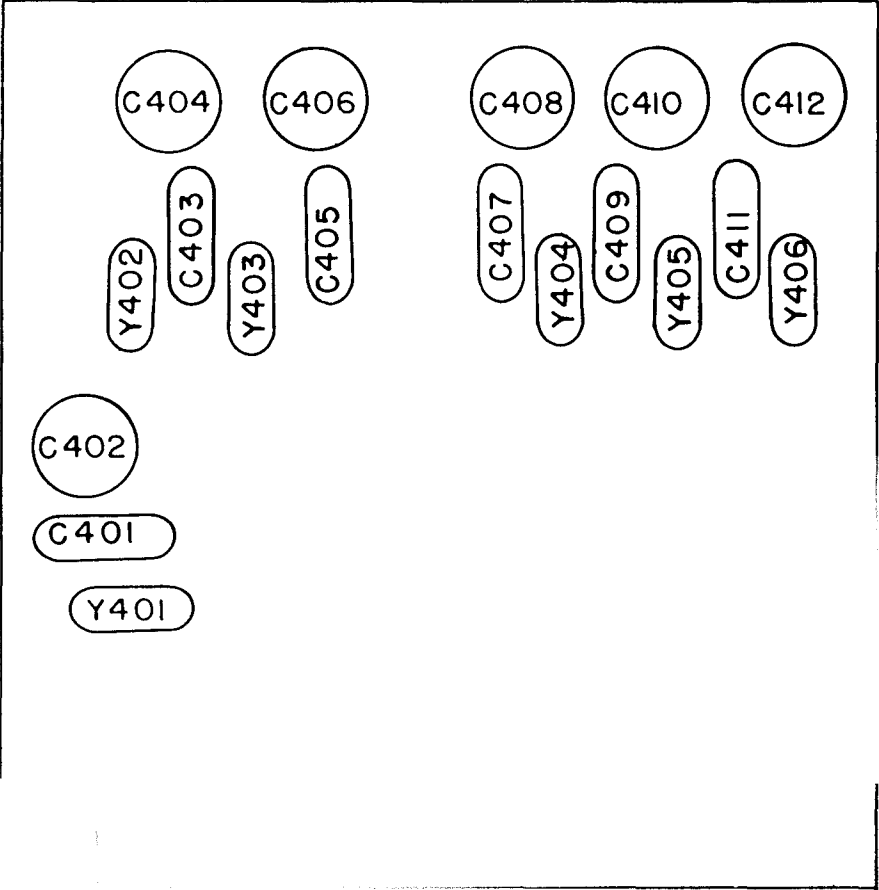

4-7 CRYSTAL-SWITCH BOARD PARTS PLACEMENT DIAGRAM

CRYSTAL-SWITCH BOARD 500-889

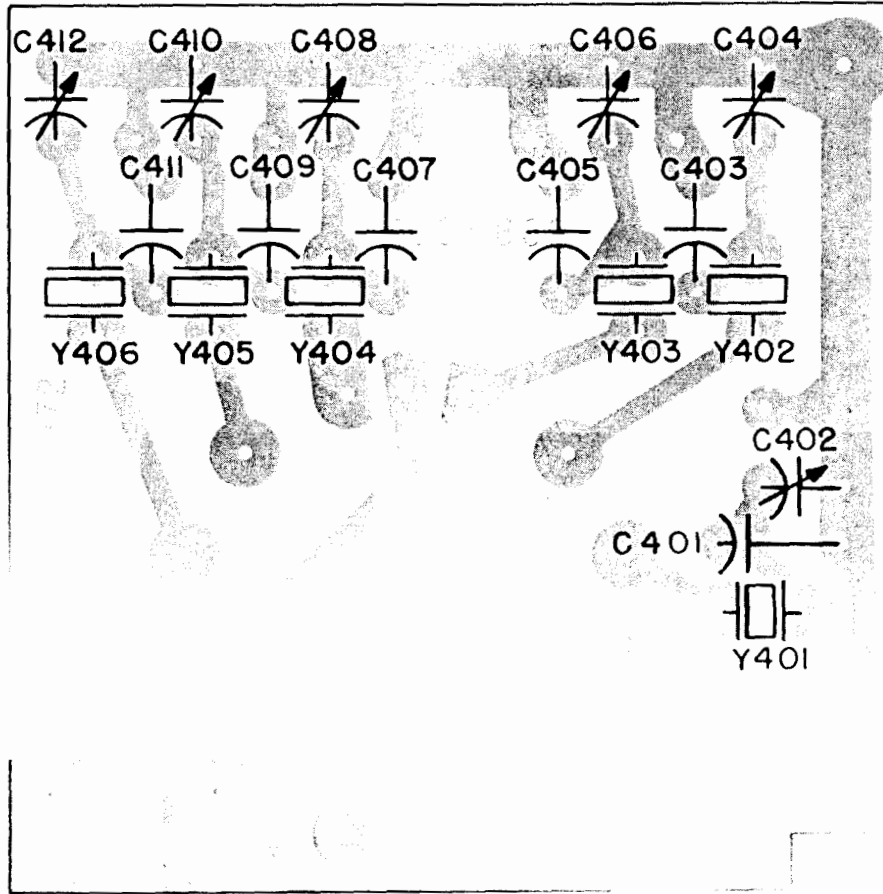

4-8 CRYSTAL-SWITCH BOARD BOTTOM VIEW

4

TRANSMITTER BOARD 500-862

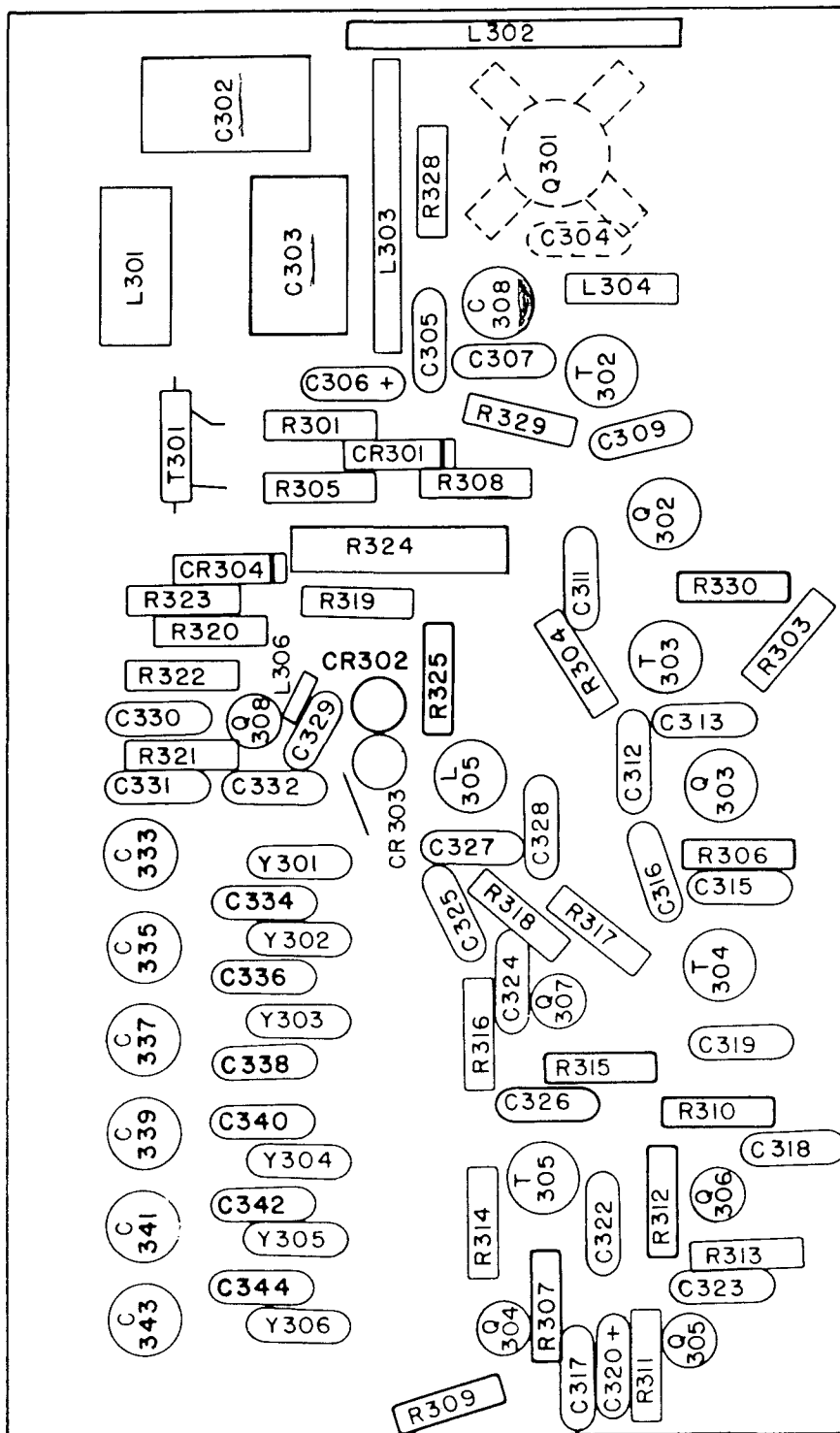

NOTE C304 & Q301 ARE ON THE BOTTOM OF THE BOARD

4-9 TRANSMITTER BOARD PARTS PLACEMENT DIAGRAM

TRANSMITTER BOARD 500-862

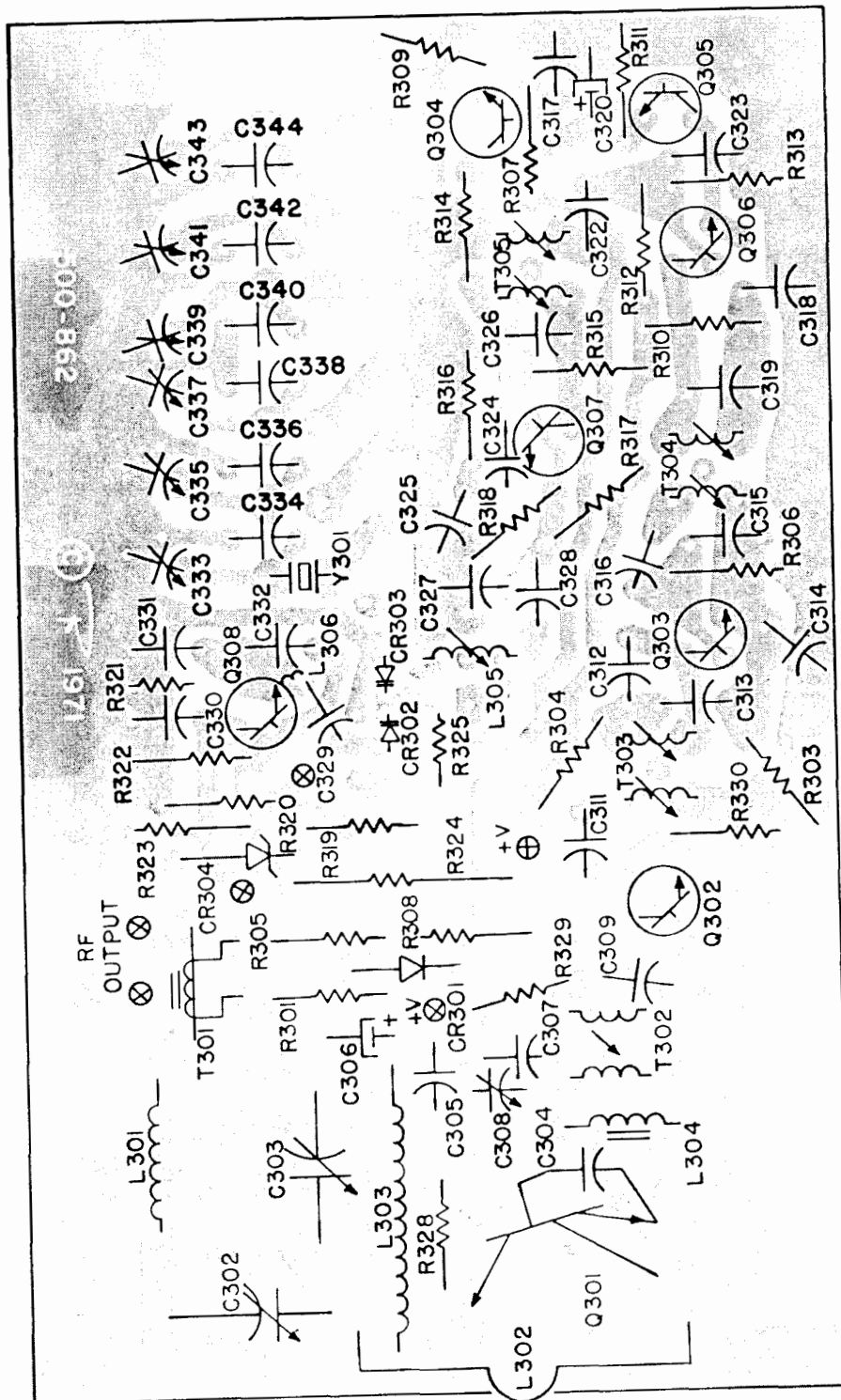

4-10 TRANSMITTER BOARD BOTTOM VIEW

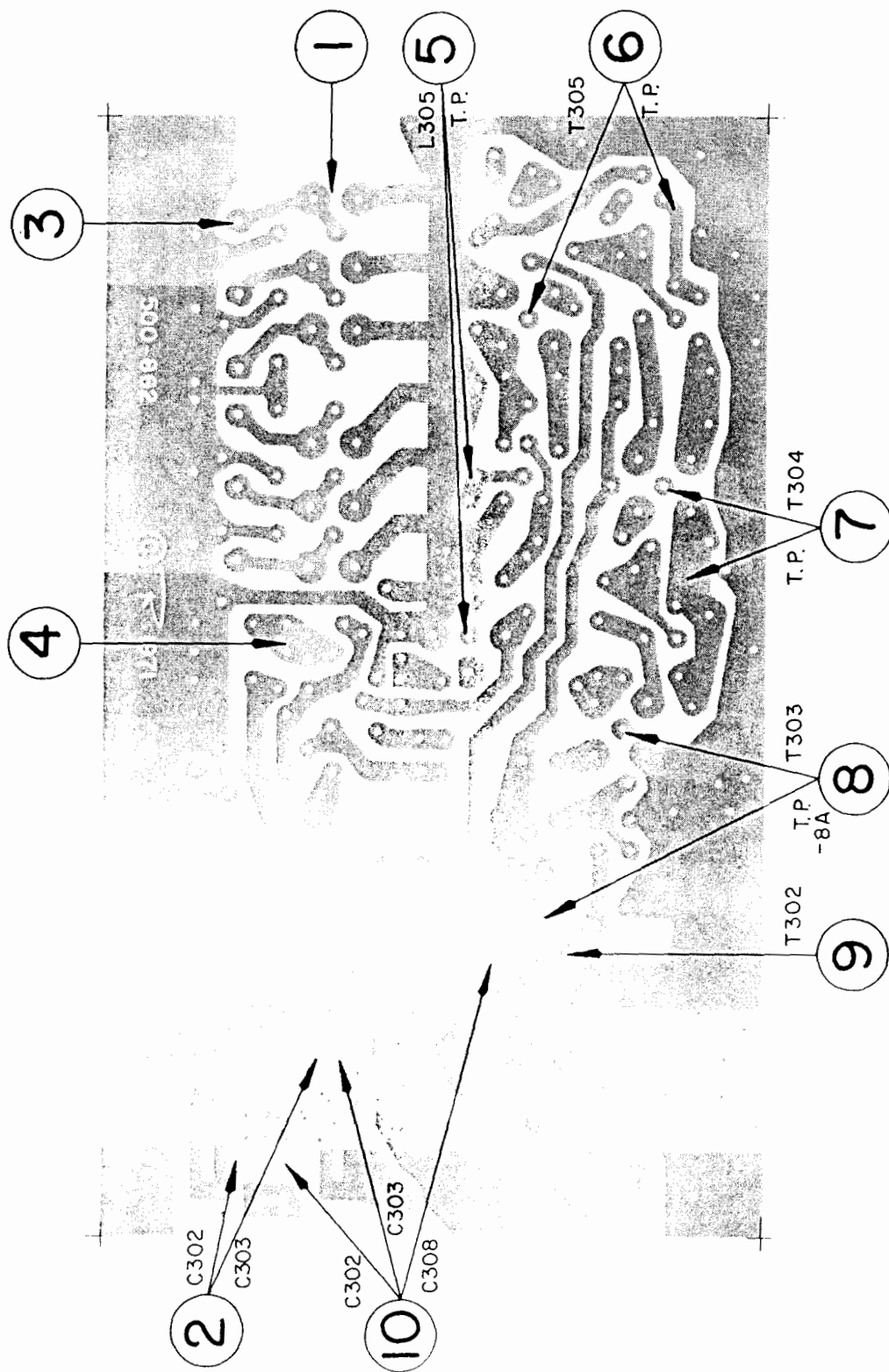

4-11 TRANSMITTER BOARD TUNE-UP TEST POINTS

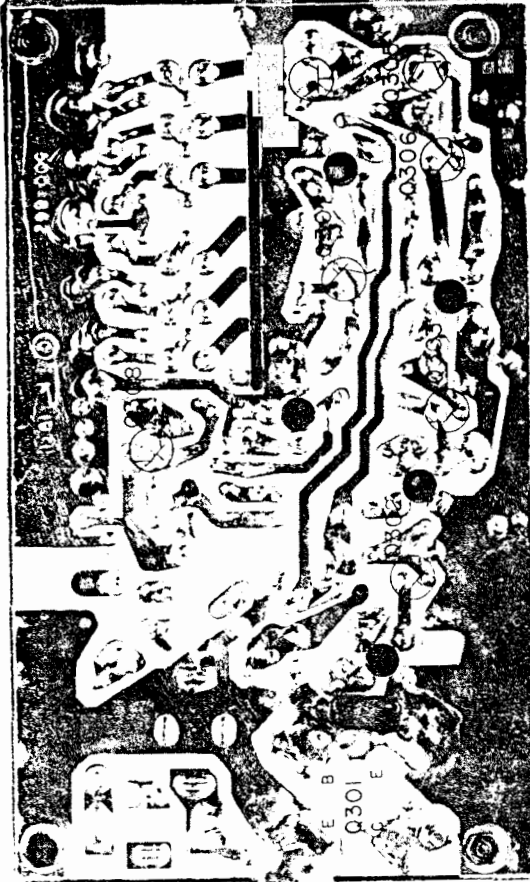
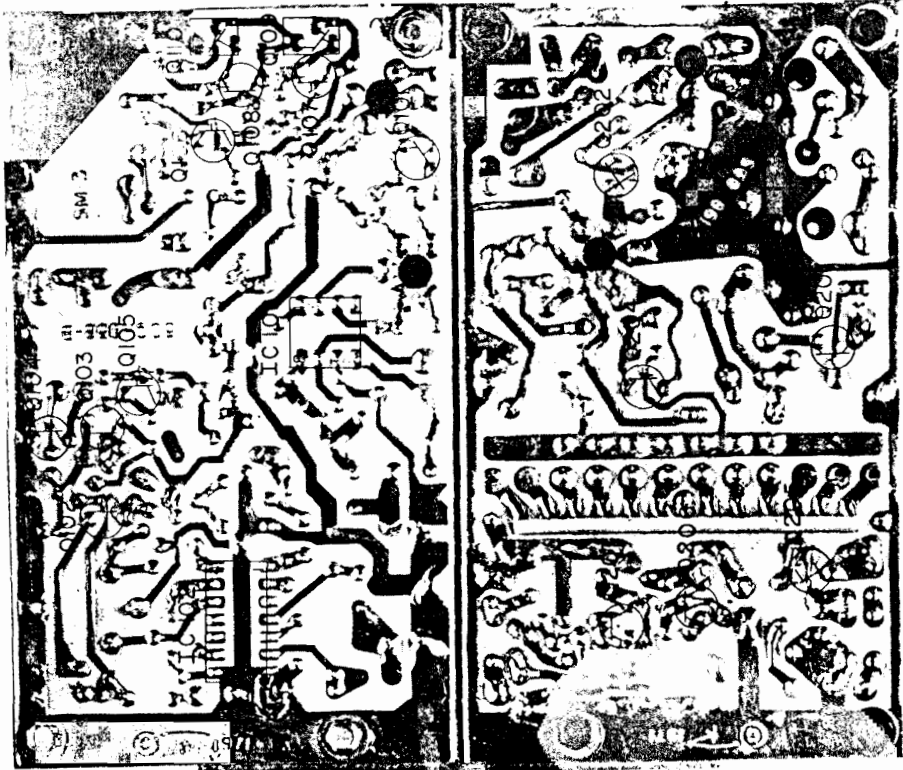

4-12 VOLTAGE DATA AND SEMICONDUCTOR LOCATION DIAGRAM

NOTE: All voltages are nominal and are measured with a VTVM. 13.8 VDC supply voltage at input to cable supplied with unit.

VOLTAGE DATA TRANSISTORS

	<u>Transistor</u>	<u>Emitter (Source)</u>	<u>Base (Gate)</u>	<u>Collector (Drain)</u>
RF Board	Q201	3.8	4.5	6.9
No.500-861	Q202 (FET)	1.0	—	6.2
	Q204	4.4	5.0	7.2
	Q205 (FET)	.80	—	5.0
	Q206	.20	.80	4.6
	Q207	.15 — .30	.65 — .90	6.0* (*varies with setting of R228)
	IF Board	Q101	2.3	3.0
No. 500-858	Q102	1.0	1.7	4.8
	Q103 (PNP)	8.2	8.2	0 (unscquelched)
		8.2	8.2	1.0 (scquelched)
		8.2	8.2	1.5 min. (tight scquelch)
	Q104	0	0	1.9 (unscquelched)
		0	.80	.30 (scquelched)
		0	.80	.10 (tight scquelch)
	Q105	1.4	1.9	5.1 (unscquelched)
		1.1	.10	8.2 (tight scquelch)
	Q106	0.7	1.3	12.4
	Q107 (PNP)	13.8	13.3	7.2
	Q108 (PNP)	6.9	6.6	.10
	Q109	6.9	7.2	13.8
	Q110	0	.10	6.9
	Q301	0	-0.5	13.2
	Q302	0	-.4	12.1
	Q303	.50	-.2	12.4
	Q304	0	.33	2.3
	Q305	1.4	2.3	1.6
	Q306	1.6	1.0	13.1
Q307	1.9	1.4	12.2	
Q308	2.5	2.8	8.2	

VOLTAGE DATA - INTEGRATED CIRCUITS

NOTE: Both IC's are located on the IF Board, 500-858.

IC No.	<u>1</u>	<u>2</u>	<u>3</u>	<u>4</u>	<u>5</u>	<u>6</u>	<u>7</u>	<u>8</u>	<u>9</u>	<u>10</u>	<u>11</u>	<u>12</u>	<u>13</u>	<u>14</u>
IC 101	4.2	.7	.7	4.2	7.8	0	4.2	7.8	—	—	—	—	—	—
IC102	4.0	3.5	OV	1.3	1.3	1.3	0	0	0.2	1.4	2.9	3.5	7.6	5.0

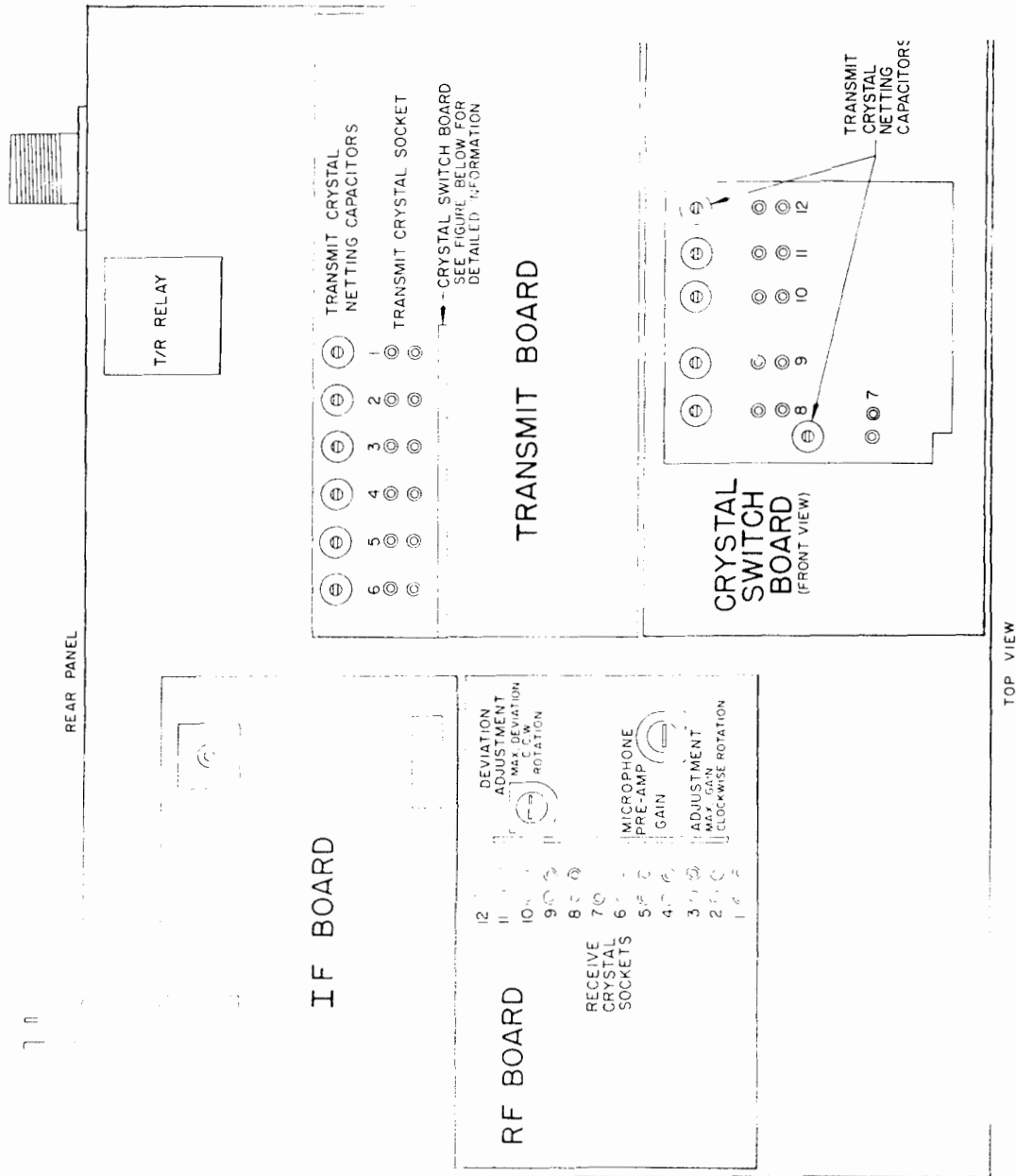

4-13 CRYSTAL LOCATION AND ADJUSTMENT DIAGRAM

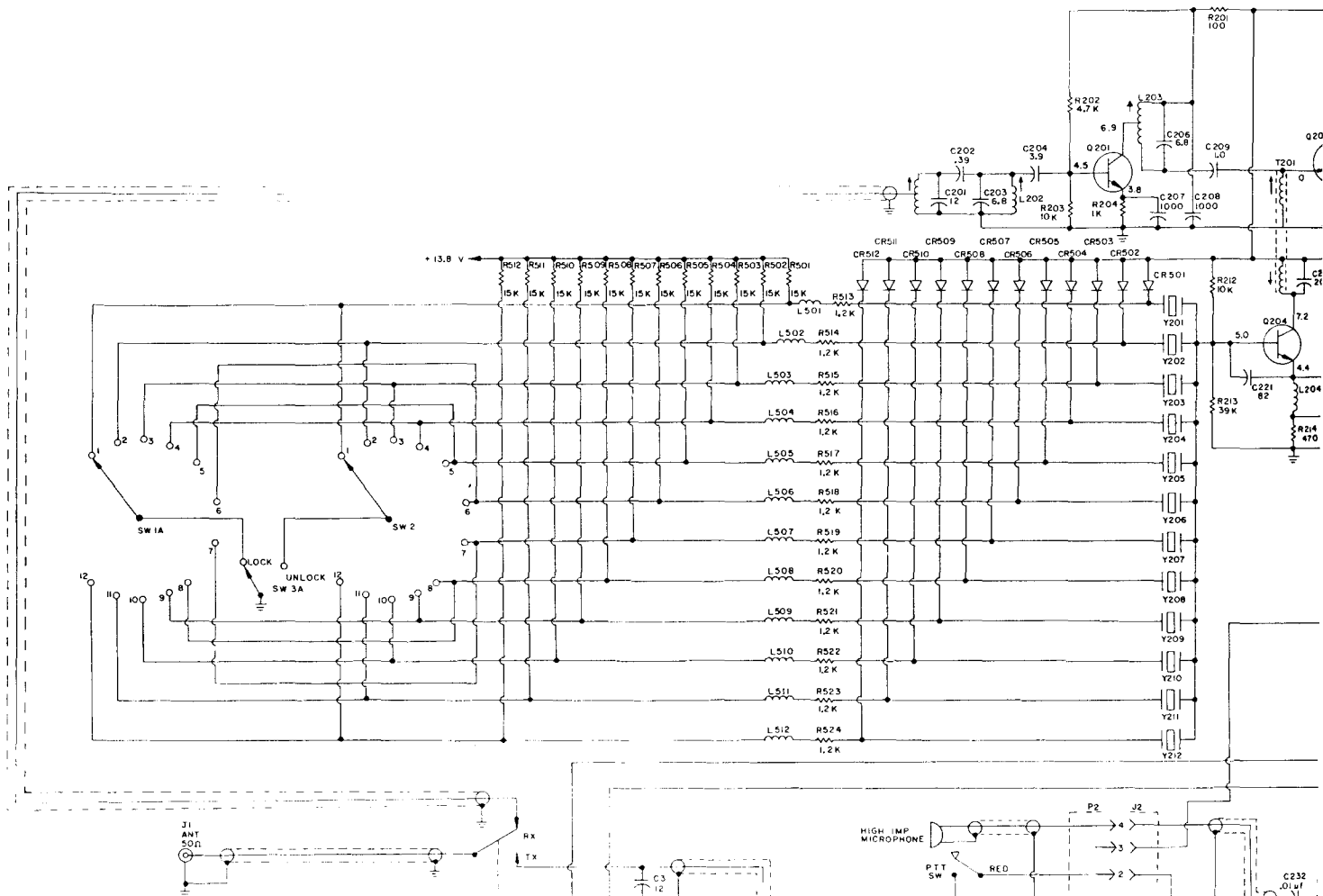

NOTES:

1. ALL CAPACITOR VALUES NOT SPECIFIED ARE PICO-FARAD.
 - ALL RESISTOR VALUES NOT SPECIFIED ARE OHMS, 1/4 WATT.
 2. * NOTED VALUES ARE FACTORY SELECTED, NOMINAL VALUES SHOWN.
 3. L306 IS A FERRITE BEAD PLACED ON THE EMITTER LEAD OF Q308.
 4. ALL VOLTAGES (FIGURES IN RED) ARE NOMINAL VALUES AS MEASURED WITH A VTVM, SUPPLY VOLTAGE +13.8VDC AT INPUT TO POWER CABLE SUPPLIED WITH UNIT.
- a. LETTER FOLLOWING A VOLTAGE INDICATES THE FOLLOWING CONDITIONS:
- U: UNSQUELCHED
 - S: SQUELCHED - THRESHOLD
 - T: SQUELCHED - TIGHT
- b. VOLTAGES INDICATED IN TRANSMITTER SECTION ARE MEASURED WITH THE TRANSMITTER IN OPERATION AND CONNECTED TO A PROPER LOAD.

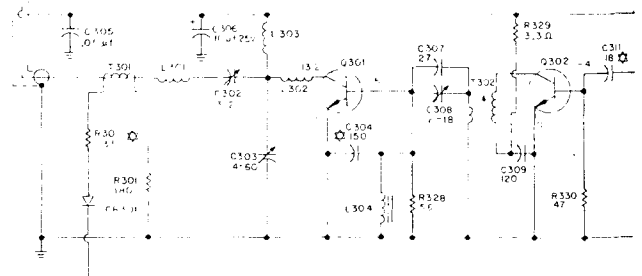

4-14 SCHEMATIC DIAGRAM

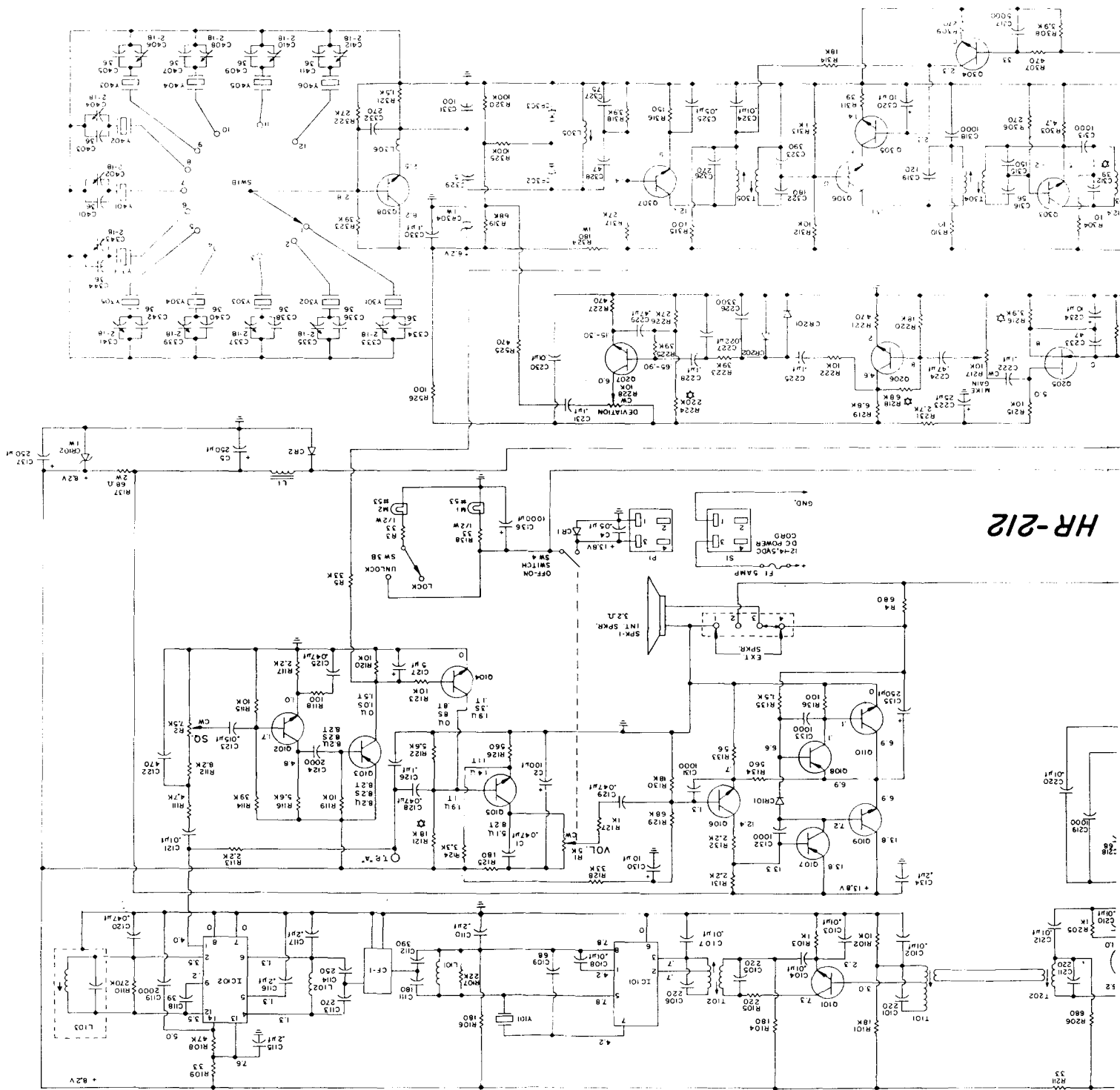

HR-212

SECTION 5 PARTS LIST

5-1 RF-MODULATOR BOARD 500-861

Item No.	Description	Part No.	Item No.	Description	Part No.
RESISTORS					
R201	100 ohm, 10%, ¼W		C223	25 mf, 85°C 10V (Electrolytic)	
R202	4.7K, 10%, ¼W		C224	.47 mf +80%–20% 3V (Disc.)	RMC–Type M-3
R203	10K, 10%, ¼W		C225	.1 mf, 20% 12V (Disc.)	Murata Type BC-12
R204	1K, 10%, ¼W		C226	.0033 mf, 10% 100V (Mylar Film)	
R205	1K, 10%, ¼W		C227	.022 mf, 10% 100V (Mylar Film)	
R206	680 ohm, 10%, ¼W		C228	.1 mf, 20% 12V (Disc.)	Murata Type BC-12
R211	68 ohm, 10%, ¼W		C229	.47 mf +80%–20% 3V (Disc.)	RMC–Type M-3
R212	10K, 10%, ¼W		C230	.01 mf, 10% 100V (Mylar Film)	
R213	39K, 10%, ¼W		C231	.1 mf, 20% 12V (Disc.)	Murata Type BC-12
R214	820 ohm, 10%, ¼W		C232	.01 mf, 10% 100V (Mylar Film)	
R215	10K, 10%, ¼W		C233	47 pf, 5% 50V (Mica)	DM–10 or equiv.
R216	3.9K, 10%, ¼W		C234	10 mf, 85°C 10V (Electrolytic)	
R217	Trimmer 10K, 20% (Lay Down)	Amperex EO 86 BD/10K	COILS		
R218	68K, 10%, ¼W		L201	Coil, Antenna (Brown)	301-520-1
R219	6.8K, 10%, ¼W		L202	Coil, RF Input (Red)	301-520-2
R220	18K, 10%, ¼W		L203	Coil, RF Output (Black)	301-520-8
R221	470 ohm, 10%, ¼W		L204	Coil, RF Osc.	102-369
R222	10K, 10%, ¼W		T201	Coil, Osc. Output FET Input	301-727
R223	39K, 10%, ¼W		T202	Coil, FET Output	301-701
R224	220K, 10%, ¼W		TRANSISTORS		
R225	39K, 10%, ¼W		Q201	Silicon NPN, 2N5222	SPS-1473 (RT)
R226	27K, 10%, ¼W		Q202	Silicon, N-Channel FET	2N5668
R227	470 ohm, 10%, ¼W		Q204	Silicon, NPN 2N5130 (Low Beta)	SM-4304-S
R228	Trimmer 10K, 20% (Lay Down)	Amperex EO 86 BD/10K	Q205	Silicon, N-Channel FET	2N5668
R229	10K, 10%, ¼W		Q206	Silicon NPN, MPS 5172	SPS 952
R230	100K, 10%, ¼W		Q207	Silicon NPN, MPS 5172	SPS 952
R231	2.7K, 10%, ¼W		NOTE: RT = Red Top		
CAPACITORS					
C201	12 pf, 10% NPO (Disc.)	RMC–Type CG	DIODES		
C202	.39 pf, 10% (Composition)		CR201	Silicon, General Purpose, IN4148	102-412
C203	6.8 pf, 10% NPO (Disc.)	RMC–Type CG	CR202	Silicon, General Purpose, IN4148	102-412
C204	3.9 pf, 10% NPO (Disc.)	RMC–Type CG			
C206	6.8 pf, 10% NPO (Disc.)	RMC–Type CG			
C207	.001 mf +80%–20% 500V, Z5U (Disc.)	RMC–Type BG			
C208	.001 mf +80%–20% 500V, Z5U (Disc.)	RMC–Type BG			
C209	1.0 pf, 10% (Composition)				
C210	.01 mf +80%–20% 500V, Z5U (Disc.)	RMC–Type BG			
C211	220 pf, 5% 50V (Mica)	DM–10 or equiv.			
C212	.01 mf +80%–20% 500V, Z5U (Disc.)	RMC–Type BG			
C217	20 pf, 10% NPO (Disc.)	RMC–Type CG			
C218	68 pf, 5% 50V (Mica)	DM–10 or equiv.			
C219	.001 mf +80%–20% 500V, Z5U (Disc.)	RMC–Type BG			
C220	.01 mf +80%–20% 500V, Z5U (Disc.)	RMC–Type BG			
C221	82 pf, 5% 50V (Mica)	DM–10 or equiv.			
C222	.1 mf, 20% 12V (Disc.)	Murata Type BC-12			

5-2 IF-AUDIO BOARD 500-858

Item No.	Description	Part No.	Item No.	Description	Part No.
RESISTORS					
R101	18K, 10%, ¼W		C111	180 pf, 5% 50V (Mica)	DM-10 or equiv.
R102	10K, 10%, ¼W		C112	390 pf, 5% 50V (Mica)	DM-10 or equiv.
R103	1K, 10%, ¼W		C113	270 pf, 5% 50V (Mica)	DM-10 or equiv.
R104	180 ohm, 10%, ¼W		C114	250 pf, 5% 50V (Mica)	DM-10 or equiv.
R105	220 ohm, 10%, ¼W		C115	.2 mf, +80%–20% 12V (Disc.)	Murata Type BC-12
R106	180 ohm, 10%, ¼W		C116	.2 mf, +80%–20% 12V (Disc.)	Murata Type BC-12
R107	22K, 10%, ¼W		C117	.2 mf, +80%–20% 12V (Disc.)	Murata Type BC-12
R108	47K, 10%, ¼W		C118	39 pf, 10% NPO (Disc.)	RMC-Type CG
R109	33 ohm, 10%, ¼W		C119	.002 mf, 20% 500V Z5F (Disc.)	RMC-Type JG
R110	270K, 10%, ¼W		C120	.047 mf, 10% 100V (Mylar Film)	
R111	4.7K, 10%, ¼W		C121	.01 mf, 10% 100V (Mylar Film)	
R112	8.2K, 10%, ¼W		C122	470 pf, 20% 500V Z5F (Disc.)	RMC-Type JG
R113	2.2K, 10%, ¼W		C123	.015 mf, 10% 100V (Mylar Film)	
R114	39K, 10%, ¼W		C124	.002 mf, 20% 500V Z5F (Disc.)	RMC-Type JG
R115	10K, 10%, ¼W		C125	.047 mf, 10% 100V (Mylar Film)	
R116	2.7K, 10%, ¼W		C126	.1 mf, 20% 12V (Disc.)	Murata Type BC-12
R117	1K, 10%, ¼W		C127	5 mf, 85°C 25V (Electrolytic)	
R118	100 ohm, 10%, ¼W		C128	.047 mf, 10% 100V (Mylar Film)	
R119	10K, 10%, ¼W		C129	.047 mf, 10% 100V (Mylar Film)	
R120	10K, 10%, ¼W		C130	10 mf, 85°C 10V (Electrolytic)	
R121	15K, 10%, ¼W		C131	.001, +80%–20% 500V Z5U (Disc.)	RMC-Type BG
R122	5.6K, 10%, ¼W		C132	.001, +80%–20% 500V Z5U (Disc.)	RMC-Type BG
R123	10K, 10%, ¼W		C133	.001, +80%–20% 500V Z5U (Disc.)	RMC-Type BG
R124	5.6K, 10%, ¼W		C134	.2 mf, +80%–20% 12V (Disc.)	Murata Type BC-12
R125	180 ohm, 10%, ¼W		C135	250 mf, 85°C 16V (Electrolytic)	
R126	820 ohm, 10%, ¼W		C136	1000 mf, 85°C 16V (Electrolytic)	
R127	1K, 10%, ¼W		C137	250 mf, 85°C 10V (Electrolytic)	
R128	33K, 10%, ¼W		COILS		
R129	68K, 10%, ¼W		T101	Coil, 10.7 MHz Input	102-507
R130	18K, 10%, ¼W		T102	Coil, 10.7 MHz Output	301-683
R131	2.2K, 10%, ¼W		L101	Choke, 820 uh, 5%	ES-2502
R132	2.2K, 10%, ¼W		L102	Choke, 820 uh	ES-2228
R133	56 ohm, 10%, ¼W		L103	Coil, Quadrature	301-517
R134	560 ohm, 10%, ¼W		INTEGRATED CIRCUITS		
R135	1.5K, 10%, ¼W		IC101	Integrated Circuit	301-679-1
R136	100 ohm, 10%, ¼W		IC102	Integrated Circuit, MC-1357P	301-576-3
R137	68 ohm, 10%, 2W (Wire Wound)	IRC-Type 8WH	TRANSISTORS		
R138	33 ohm, 10%, ½W		Q101	NPN Silicon MPS 5172	SPS-952
CAPACITORS			Q102	NPN Silicon MPS 5172	SPS-952
C101	220 pf, 5% 50V (Mica)	DM-10 or equiv.	Q103	PNP Silicon 2N5227	SPS-1539 (WT)
C102	.01 mf, 10% 100V (Mylar Film)		Q104	NPN Silicon MPS 5172	SPS-952
C103	.01 mf, +80%–20% 500V Z5U (Disc.)	RMC-Type BG	Q105	NPN Silicon MPS 5172	SPS-952
C104	.01 mf, 10% 100V (Mylar Film)		Q106	NPN Silicon MPS 5172	SPS-952
C105	220 pf, 5% 50V (Mica)	DM-10 or equiv.	Q107	PNP Silicon	MPS-A55
C106	220 pf, 5% 50V (Mica)	DM-10 or equiv.	Q108	PNP Silicon	MPS-A55
C107	.01 mf +80%–20% 500V Z5U (Disc.)	RMC-Type BG	Q109	NPN Silicon AF Power	MJE-521
C108	.01 mf +80%–20% 500V Z5U (Disc.)	RMC-Type BG	Q110	NPN Silicon AF Power	MJE-521
C109	68 pf, 5% 50V (Mica)	DM-10 or equiv.	NOTE	WT = White Top	
C110	2 mf, +80%–20% 12V (Disc.)	Murata Type BC-12			

Item No.	Description	Part No.
DIODES		
CR101	Silicon, Signals, IN4148	102-412
CR102	Silicon, Zener, 8.2V 5% 1W	1N4738A
FILTER		
CF-1	455 KHz Ceramic Filter	301-723
CRYSTAL		
Y101	10.245 MHz or	301-516-1
	11.155 MHz	301-516-2

5-3 DIODE SWITCHING BOARD 500-887

Item No.	Description	Part No.	Item No.	Description	Part No.
RESISTORS			CR506	Germanium-Junction, Signal	102-339
R501	15K, 10%, ¼W		CR507	Germanium-Junction, Signal	102-339
R502	15K, 10%, ¼W		CR508	Germanium-Junction, Signal	102-339
R503	15K, 10%, ¼W		CR509	Germanium-Junction, Signal	102-339
R504	15K, 10%, ¼W		CR510	Germanium-Junction, Signal	102-339
R505	15K, 10%, ¼W		CR511	Germanium-Junction, Signal	102-339
R506	15K, 10%, ¼W		CR512	Germanium-Junction, Signal	102-339
R507	15K, 10%, ¼W				
R508	15K, 10%, ¼W				
R509	15K, 10%, ¼W				
R510	15K, 10%, ¼W				
R511	15K, 10%, ¼W				
R512	15K, 10%, ¼W				
R513	1.2K, 10%, ¼W				
R514	1.2K, 10%, ¼W				
R515	1.2K, 10%, ¼W				
R516	1.2K, 10%, ¼W				
R517	1.2K, 10%, ¼W				
R519	1.2K, 10%, ¼W				
R520	1.2K, 10%, ¼W				
R521	1.2K, 10%, ¼W				
R522	1.2K, 10%, ¼W				
R523	1.2K, 10%, ¼W				
R524	1.2K, 10%, ¼W				
R525	470 ohm, 10%, ¼W				
R526	100 ohm, 10%, ¼W				
CHOKES					
L501	6.8 uh, 10%, RF Choke	Wilco ML68G			
L502	6.8 uh, 10%, RF Choke	Wilco ML68G			
L503	6.8 uh, 10%, RF Choke	Wilco ML68G			
L504	6.8 uh, 10%, RF Choke	Wilco ML68G			
L505	6.8 uh, 10%, RF Choke	Wilco ML68G			
L506	6.8 uh, 10%, RF Choke	Wilco ML68G			
L507	6.8 uh, 10%, RF Choke	Wilco ML68G			
L508	6.8 uh, 10%, RF Choke	Wilco ML68G			
L509	6.8 uh, 10%, RF Choke	Wilco ML68G			
L510	6.8 uh, 10%, RF Choke	Wilco ML68G			
L511	6.8 uh, 10%, RF Choke	Wilco ML68G			
L512	6.8 uh, 10%, RF Choke	Wilco ML68G			
DIODES					
CR501	Germanium-Junction, Signal	102-339			
CR502	Germanium-Junction, Signal	102-339			
CR503	Germanium-Junction, Signal	102-339			
CR504	Germanium-Junction, Signal	102-339			
CR505	Germanium-Junction, Signal	102-339			

5-4 CRYSTAL-SWITCH BOARD 500-889

Item No.	Description	Part No.
C401	36pf, 5% NPO (Disc.)	RMC-Type CG
C402	2-18pf, Trimmer	Amperex HT10KA/218
C403	36pf, 5% NPO (Disc.)	RMC-Type CG
C404	2-18pf, Trimmer	Amperex HT10KA/218
C405	36pf, 5% NPO (Disc.)	RMC-Type CG
C406	2-18pf, Trimmer	Amperex HT10KA/218
C407	36pf, 5% NPO (Disc.)	RMC-Type CG
C408	2-18pf, Trimmer	Amperex HT10KA/218
C409	36pf, 5% NPO (Disc.)	RMC-Type CG
C410	2-18pf, Trimmer	Amperex HT10KA/218
C411	36pf, 5% NPO (Disc.)	RMC-Type CG
C412	2-18pf, Trimmer	Amperex HT10KA/218
	Socket pins, Crystal	T35-362
	Wafer, Switch (PC Mounted)	301-422-2

5-5 TRANSMITTER BOARD 500-862

Item No.	Description	Part No.
RESISTORS		
R301	180 ohm, 10%, ¼W	
R302	4.7 ohm, 10%, ¼W	
R304	10 ohm, 10%, ¼W	
R305	330 ohm, 10%, ¼W	
R306	270 ohm, 10%, ¼W	
R307	470 ohm, 10%, ¼W	
R308	3.9K, 10%, ¼W	
R309	270 ohm, 10%, ¼W	
R310	10 ohm, 10%, ¼W	
R311	39 ohm, 10%, ¼W	
R312	10K, 10%, ¼W	
R313	1K, 10%, ¼W	
R314	18K, 10%, ¼W	
R315	100 ohm, 10%, ¼W	
R316	150 ohm, 10%, ¼W	
R317	27K, 10%, ¼W	
R318	3.9K, 10%, ¼W	
R319	68K, 10%, ¼W	
R320	100K, 10%, ¼W	
R321	1.5K, 10%, ¼W	
R322	27K, 10%, ¼W	
R323	39K, 10%, ¼W	
R324	180 ohm, 10%, 1W	
R325	100K, 10%, ¼W	
R328	47 ohm, 10%, ½W	
R329	3.3 ohm, 10%, ¼W	
R330	47 ohm, 10%, ¼W	

Item No.	Description	Part No.
CAPACITORS		
C302	3-20 pf, MICA trimmer	Elmenco 402 PC
C303	4-60 pf, MICA trimmer	Elmenco 404 PC
C304	150 pf, 5% 50V MICA	DM-15
C305	.05 mf, +80% -20%, 16V (Disc.)	RMC-Type M-16
C306	10 mf, 10% 25V TANT Electrolytic	Kemet "E" Series
C307	27 pf, 10% NPO (Disc.)	RMC-Type CG
C308	2-18 pf, Trimmer	Amperex HT10KA/218
C309	120 pf, 5% 50V MICA	DM-10
C311	18 pf, 10% NPO (Disc.)	RMC-Type CG
C312	39 pf, 5% NPO (Disc.)	RMC-Type CG
C313	.001 mf, +80% -20% 500V Z5U (Disc.)	RMC-Type BG
C315	150 pf, 5% 50V MICA	DM-10
C316	56 pf, 5% 50V MICA	DM-10
C317	.005 mf, +80% -20%, 500V Z5U (Disc.)	RMC-Type SM
C318	.001 mf, +80% -20%, 500V Z5U (Disc.)	RMC-Type BG
C319	120 pf, 5% 50V MICA	DM-10
C320	10 mf, 10% 25V TANT Electrolytic	Kemet "E" Series
C322	180 pf, 5% 50V MICA	DM-10
C323	390 pf, 5% 50V MICA	DM-10

Item No.	Description	Part No.
CAPACITORS (continued)		
C324	.01 mf, +80% -20%, 16V (Disc.)	RMC-Type M-16
C325	.05 mf, +80% -20%, 16V (Disc.)	RMC-Type M-16
C326	270 pf, 5% 50V MICA	DM-10
C327	75 pf, 5% 50V MICA	DM-10
C328	47 pf, 5% 50V MICA	DM-10
C329	5 pf, 10% NPO (Disc.)	RMC-Type CG
C330	0.1 mf, 20% 12V (Disc.)	Murata BC-12
C331	100 pf, 5% 50V MICA	DM-15
C332	270 pf, 5% 50V MICA	DM-10
C333	2-18pf, Trimmer	Amperex HT10KA/218 RMC-Type CG
C334	36pf, 5% NPO (Disc.)	Amperex HT10KA/218
C335	2-18pf, Trimmer	RMC-Type CG
C336	36pf, 5% NPO (Disc.)	Amperex HT10KA/218
C337	2-18pf, Trimmer	RMC-Type CG
C338	36pf, 5% NPO (Disc.)	Amperex HT10KA/218
C339	2-18pf, Trimmer	RMC-Type CG
C340	36pf, 5% NPO (Disc.)	Amperex HT10KA/218
C341	2-18pf, Trimmer	RMC-Type CG
C342	36pf, 5% NPO (Disc.)	Amperex HT10KA/218
C343	2-18pf, Trimmer	RMC-Type CG
C344	36pf, 5% NPO (Disc.)	Amperex HT10KA/218

Item No.	Description	Part No.
COILS		
L301	Coil, Antenna output	102-447
L302	Coil, Final output	102-519
L303	Choke, RF	102-460
L304	Choke, RF	102-459
L305	Coil, Modulator	102-441
L306	Ferrite Bead (Emitter lead Q308)	Ferrox-cube 56-59065/4A
T301	Transformer, SWR Bridge	102-448
T302	Transformer, Driver output	102-445
T303	Transformer, 144MHz, (doubler)	301-663
T304	Transformer, 72MHz, (tripler)	301-662
T305	Transformer, 24MHz, (quadrupler)	301-661

Item No.	Description	Part No.
----------	-------------	----------

TRANSISTORS

Q301	NPN Silicon, RF Power Final	301-733-2
Q302	NPN Silicon, RF Power Driver	301-696-3
Q303	NPN Silicon, RF Power Doubler	2N4427
Q304	NPN Silicon, General Purpose	SPS-952
Q305	NPN Silicon	MPS-A05
Q306	NPN Silicon, Doubler	SPS-1475 (YT)
Q307	NPN Silicon, Tripler	SPS-1475 (YT)
Q308	NPN Silicon, Oscillator	SPS-1475 (YT)

NOTE: YT= Yellow Top

DIODES

CR301	Silicon, Signal, 1N4148	102-412
CR302	Silicon, Varactor	Motorola MV-2209
CR303	Silicon, Varactor	Motorola MV-2209
CR304	Silicon, Zener, 8.2V, 5%, 1 W	IN4738A

5-6 CHASSIS ASSEMBLY

Item No.	Description	Part No.
ELECTRICAL COMPONENTS		
R1	5K, Volume Control/Switch (SW4)	102-479-3
R2	7.5K, Squelch Control	102-479-2
R3	33 ohms, 10%, 1/2W	
R4	680 ohms, 10%, 1/4W	
R5	33K, 10%, 1/4W	
C1	.047 mf, 10%, 100V, Mylar Film	
C2	100 mf, 85° C, 10V, Electrolytic	
C3	12 pf, 10% NPO (Disc.)	RMC-Type CG
C4	.05 mf, +80% -20%, 25V, Y5U	RMC-Type M-25
C5	250 mf, 80° C, 16V, Electrolytic	
L1	Choke, DC Filter	301-430
CR1	Diode, Rectifier, 100 PIV 1A	IN4002
CR2	Diode, Rectifier, 100 PIV 1A	IN4002
M1	Lamp, Incandescent	No. 53
M2	Lamp, Incandescent	No. 53
RY1	Relay, Transmit-Receive, 12VDC	Potter-Brumfield KNP 14D21
Y200	Crystals, Receive (Specify Channel No.)	301-617
Y300	Crystals, Transmit (Specify Channel No.)	301-608
Y400	Crystals, Transmit (Specify Channel No.)	301-608
SW1	Switch, 12 Position	500-875-1
SW2	Switch, 12 Position	500-875-2
SW3	Switch-Rocker DPDT (Red)	UID-RSW-422 ND-B-ST-R1
SW4	Part of R1	
J1	Connector, Antenna	83-878
P1	Connector, Chassis Power	Beauchaine P-3304-AB
S1	Connector, Cable, Power	Beauchaine S-3304-FHT
P2	Connector, Cable, Microphone, 4-Pin	Switchcraft 60 HA4F
J2	Connector, Chassis, Microphone, 4-Pin	Switchcraft 09CL4M
SPK1	Speaker, 3.2 ohm, 3 1/2-inch square	1301-0000-003
F1	Fuse, 5 Ampere, 3 AG	
	Microphone, Ceramic (No connector)	500-809-2
	Microphone Assemble (Complete)	600-337-6
	DC Power Cord Assembly	102-521
	Cable Shielded, Audio	Jeffrex
	Cable, Coaxial, 50 ohms, Teflon	RG-188/u

Item No.	Description	Part No.
MECHANICAL COMPONENTS		
	Panel, Front	600-338
	Panel, Back	301-675-2
	Dial	102-223-6
	Bushing, Dial	102-202
	Knob, Channel Selector	301-788-1
	Knob, Volume & Squelch	102-310-2
	Socket Pins, Crystal	T35-362
	Heat Sink, Driver Transistor	Staver F6-5 Black
	Heat Sink, Power Transistor	301-782
	Terminal Board, 4 Lug (Rear Panel)	301-079-14
	Foot, Rubber	Lavelle 705R
	Cabinet/Wrap Assembly	600-312-4
	Bracket, Mobile Mounting	500-866
	NOTE: The 1/4-20 Hex Bolts used to mount the unit to the mounting bracket should not exceed 1/2 inch in length.	
	Bracket, Security	102-415
	Manual, Owner's Instruction	IS-10-357
	Manual, Service (\$5.00 Prepaid)	SM-10-357