

Figure 1. RF Preamplifier

TECHNICAL DATA

Power Required	
13.4 V DC \pm 20%	
6.0 mA \pm 2.0 mA	
Input and Output Impedance	
50 Ohms	
Gain MI-559632	
132-174 MHz	9.3 \pm 1.0 dB
Gain MI-559632-A	
406-435 MHz	9.0 \pm 1.0 dB
435-512 MHz	9.6 \pm 1.0 dB
Temperature Range	
-30° C to +65° C	

GENERAL

The purpose of the RF Preamplifiers is to provide increased sensitivity for 150 MHz and 450 MHz RCA receivers. The unit mounts to the receiver casting and is powered from the A+ (13.8V) line of the system. It connects between the antenna switching device and the receiver RF input. The sensitivity of the receiver is approximately doubled with the installation of the preamplifier.

The circuit consists of a single n-channel FET connected in a common gate configuration. Tuning adjustments at the input (C1) and output (C6) allow the unit to be tuned over the range of frequencies covered by the receiver.

ALIGNMENT INSTRUCTIONS

Suggested Equipment:

- Signal Generator.....Measurements 560 or 803
- Test Meter..... RCA TM 868
- Audio Voltmeter..... Ballantine 300

Procedure:

1. Feed a signal to T/R antenna jack and adjust frequency and output of signal generator for about 10uA of low-IF metering current (position 8 of TM-868). For multi-frequency receivers use a center channel.
2. Peak low-IF meter reading in this order, reducing signal generator output level to 10uA as circuits peak: 109C6, 1Z1, 1Z2, 109C1, 109C6. Repeat until maximum peaking is obtained.
3. With audio voltmeter on receiver output, adjust signal generator output for a 20 dB quieting level, maintaining "0" discriminator current (position 2+ or 2- of TM-868), adjust 109C1 for maximum quieting. This may differ somewhat from maximum gain.

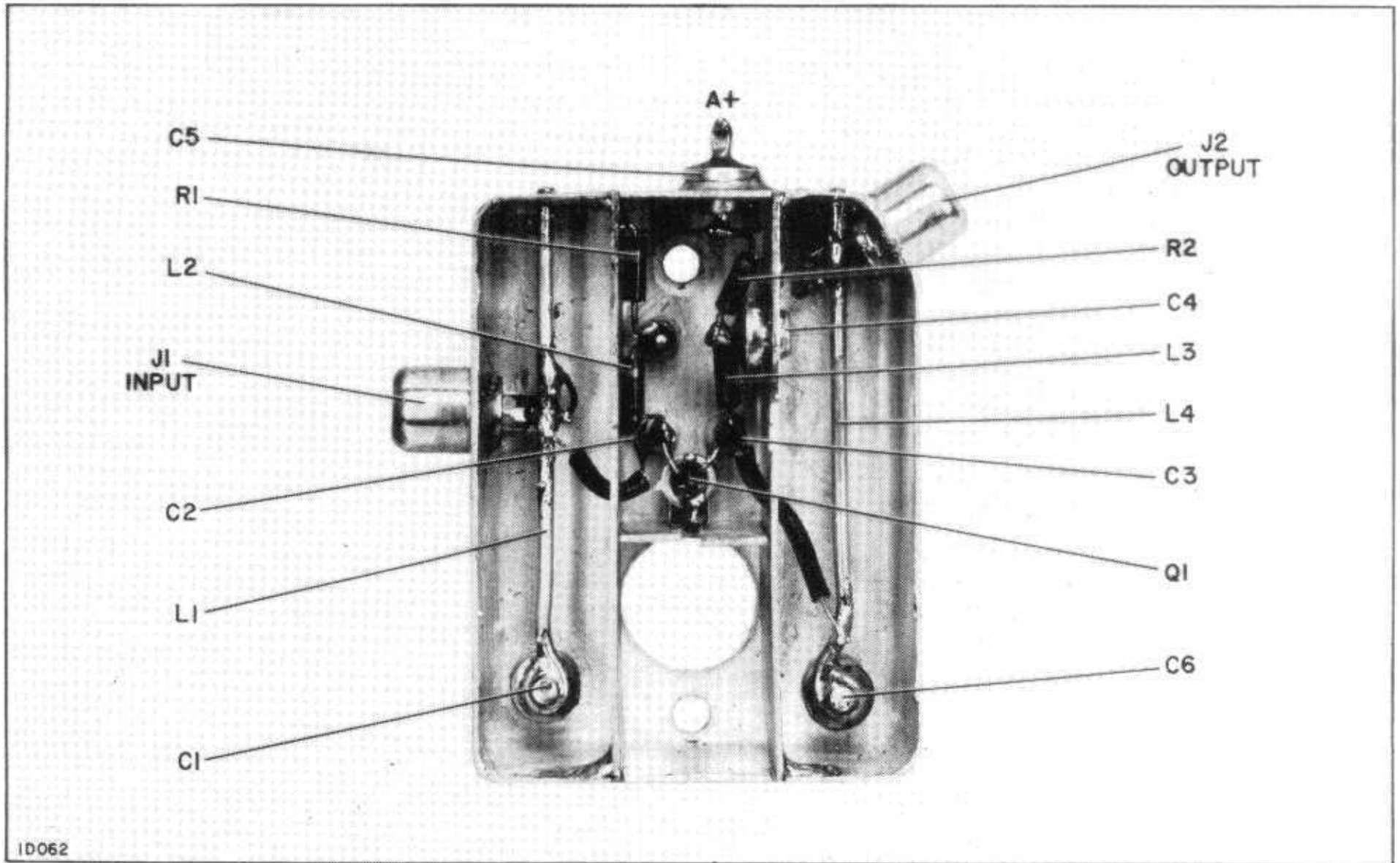

Figure 4. MI-559632-A Parts Location

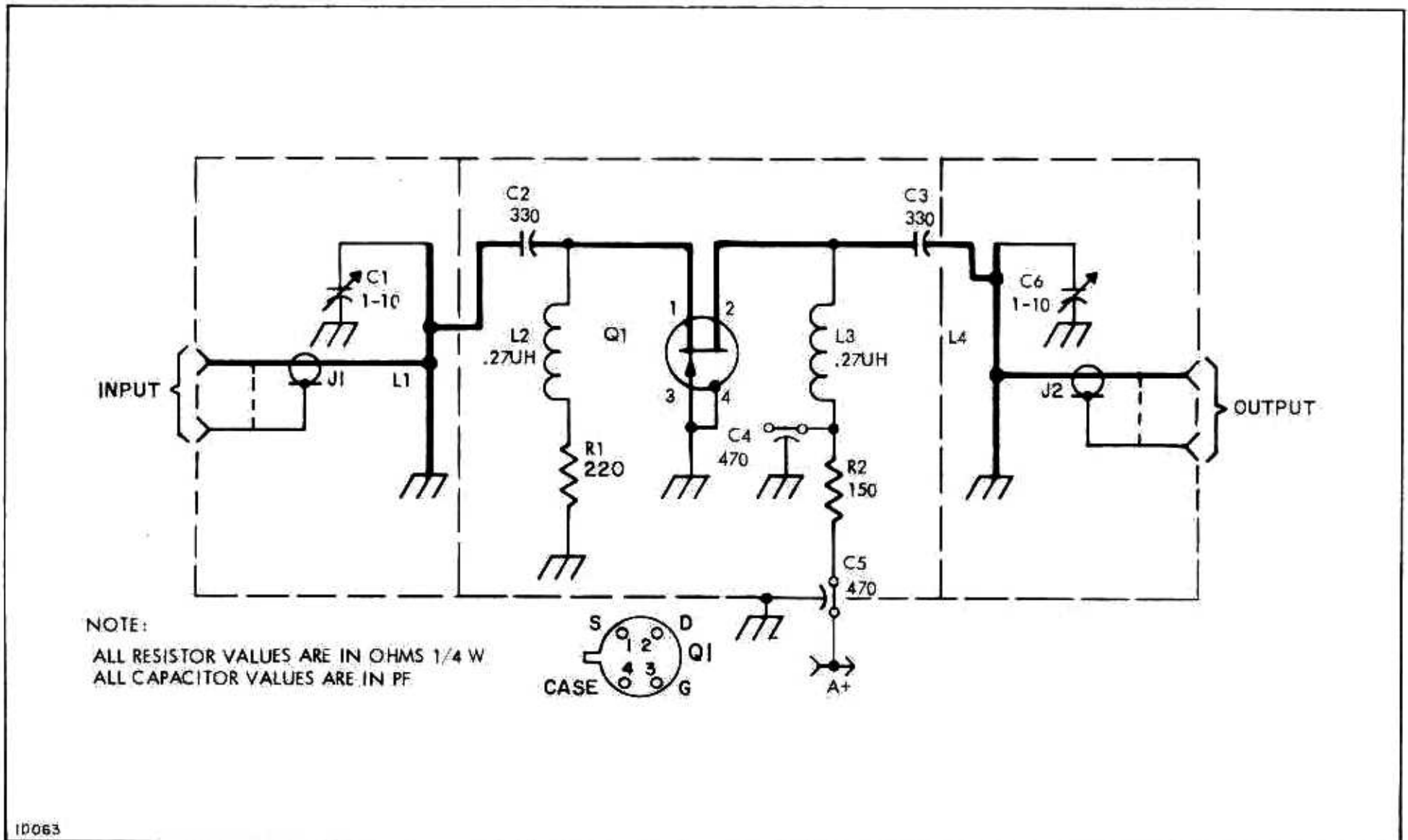

Figure 5. MI-559632-A Schematic Diagram

640897

MI-559632-A 450 MHz PREAMPLIFIER

3723242-502

109C1	423915	3720050-006	VARIABLE, 1-10 PF
109C2	423916	3720541-106	330 PF 20%
109C3	423916	3720541-106	330 PF 20%
109C4	243256	3450092-201	STAND-CFF, 470 PF 20%
109C5	239159	3450097-201	FEED-THRU, 470 PF 20%
109C6	423915	3720050-006	VARIABLE, 1-10 PF
109J1	422896	3723009-001	JACK, PHONO
109J2	422896	3723009-001	JACK, PHONO
109L1	423912	3723312-001	CHOKE
109L2	423917	3463115-024	CHOKE, 0.27 UH 20%
109L3	423917	3463115-024	CHOKE, 0.27 UH 20%
109L4	423912	3723312-001	CHOKE
109Q1	423914	3723316-001	TRANSISTOR
109R1	218758	99206-054	220 OHMS 10% 1/4W
109R2	227744	99206-052	150 OHMS 10% 1/4W
	423920	3468006-532	CABLE ASSY
	423919	3468006-533	CABLE ASSY
	242161	3450797-002	CONNECTOR, BEAD CHAIN