

# "Smart" Squelch for SSB

**Editor's Note:** W9MKV and W9YAN's "Smart Squelch" overwhelmed the competition to win the first 73 Magazine Home-Brew Contest. The authors received a \$250 prize in addition to the normal article payment. You can build this trend-setting project; W9MKV offers a PC board for \$7.00 and a complete parts kit is available from Radiokit, Box 411, Greenville NH 03048, for \$49.95. Congratulations to W9MKV and W9YAN for a job well done.

Frank S. Reid W9MKV  
PO Box 5283  
Bloomington IN 47402

David A. Link W9YAN  
213 Western Drive  
Bloomington IN 47401

This circuit detects the human voice but ignores noise, steady tones, and the Russian woodpecker HF radar pulses. It requires no receiver modification and works even when voice signals are below the noise level.

A squelch turns off receiver audio to eliminate annoying background noise when there is no signal. Squelch circuits in AM and FM receivers are carrier-operated. On single sideband, which has no carrier, squelching is more difficult. Most SSB rigs with squelch, e.g., the popular 2-meter multimode transceivers, use agc (S-meter) voltage to open squelch in SSB mode. Agc-operated squelch is adequate for strong signals on relatively quiet channels. Agc and VOX-type squelch-

es open for any noise or heterodyne that exceeds a preset level. Weak signals often are missed because the threshold must be set above the noise level.

White noise sometimes can make you imagine tiny voices in the noise, but it won't fool the Smart Squelch. Detecting unreadably-weak signals is worthwhile if a change of antenna direction or receiver control settings will make them usable.

The audio-operated squelch circuit described

here is similar in principle to Motorola's "Constant Signal" squelch, a discrete-component circuit with 22 transistors.

## Discriminating the Human Voice

People normally speak about three syllables per second. The squelch works by detecting voice-band energy (500-3000 Hz) which is varying in frequency at a rate of 0.5 to 3.25 Hz.

The circuit is a type of FM detector. It is insensitive to amplitude variations throughout the range where the input stage is not driven to saturation but background noise is strong enough to saturate the limiter. The squelch works properly with most speaker-level signals. You can connect it directly to the receiver's detector output, adjusting gain of input buffer amplifier U1A as necessary.

## Performance

A receiver tuned to WWV provides a good demonstration of the circuit's capabilities. Squelch opens for voice announcements and ignores the rest of the transmissions.

The squelch can turn on well within the first spoken syllable. Speed of response depends mostly upon the rise-time of active low-pass filter U3A. The receiver is muted one second after the last voice detection. The beginning of a steady tone



Photo A. Squelch unit is attached to the right side of the HF SSB transceiver. Rectangular LEDs above the control knob indicate circuit status. (Photo by KA9FJS)



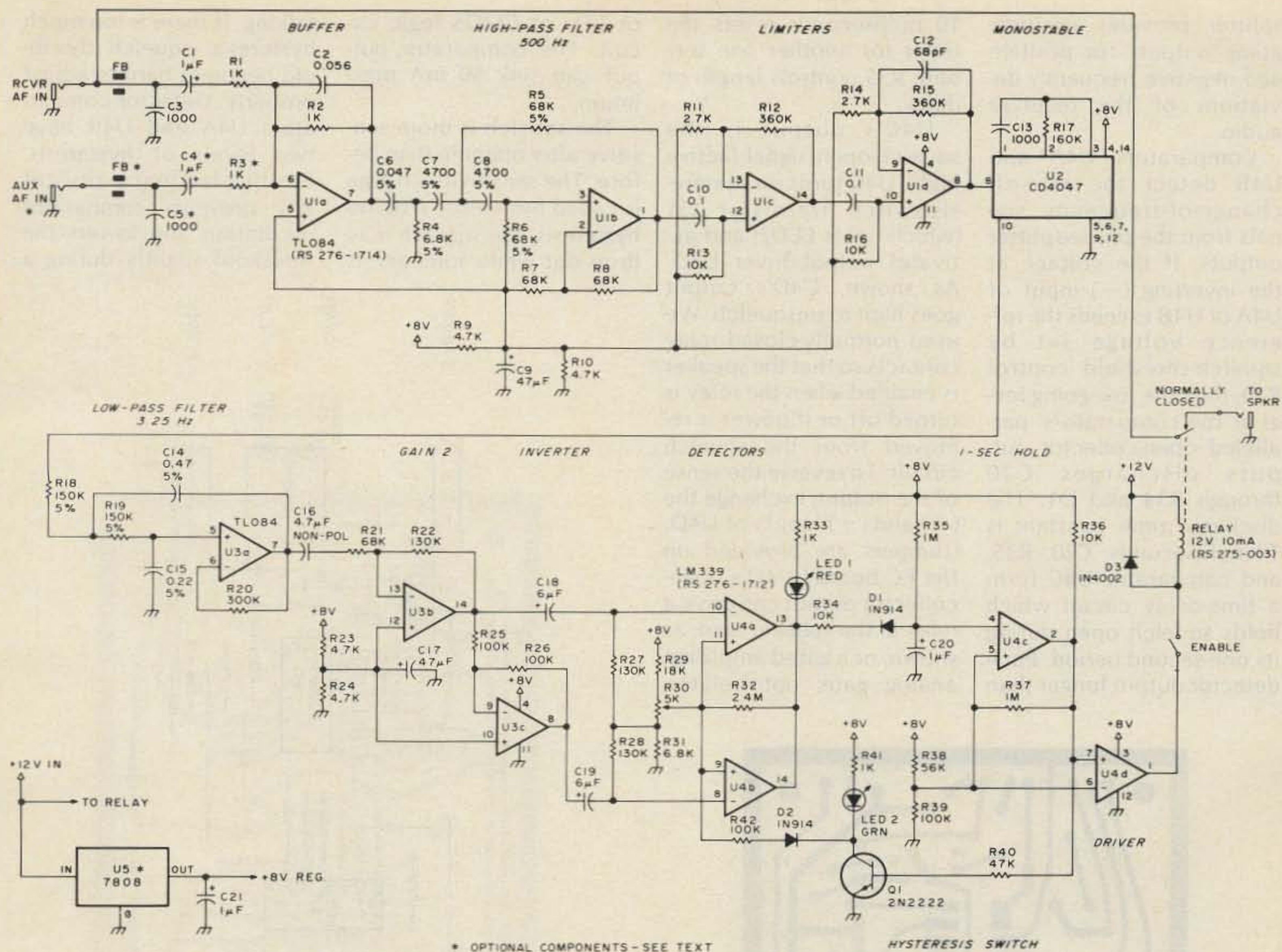

Fig. 1. Schematic diagram.

opens the squelch only momentarily. It opens intermittently on music. Response to CW depends on code speed and tone.

A single squelch circuit can control multiple receivers, unsquelching them all when any receiver detects a voice signal. (We like to monitor HF aircraft and marine frequencies plus 144.2 MHz—the 2-meter SSB calling frequency.)

The squelch is useful when rf radiation from computer systems overwhelms the normal squelch in a VHF FM receiver. It's also good for monitoring VHF/UHF mobile-telephone channels in systems where a constant idle tone is transmitted while no call is in progress. The circuit has other applications as a

"smart" VOX (voice-operated switch) for transmitters, recorders, intercoms, security systems, remote-base systems, and repeater equipment.

### Circuit Description

U1A is a unity-gain summing amplifier, input buffer, and low-pass filter with 3-kHz cutoff. U1A drives U1B, a third-order high-pass active filter with 3-dB cutoff at 500 Hz. We chose high-performance FET-input operational amplifiers so that active filters could use high resistances and small capacitors. The TL084 quad op-amp chip is equivalent to the National LF357.

U1C and U1D are limiter amplifiers with a combined gain of 85 dB. U1D's output is voice-band audio turned into constant-amplitude

square waves. The square waves trigger CMOS monostable multivibrator U2. Output of U2 is a train of .33-millisecond pulses, one for each audio cycle. The average voltage of U2's output is proportional to the input frequency. U2 and the following low-pass filter form a frequency-to-voltage converter, i.e., FM detector, somewhat similar to an automobile tachometer circuit.

Active low-pass filter U3A cuts off at 3.25 Hz, the best compromise between noise-falsing and the rate at which people speak syllables.<sup>2</sup> Note that U3A has no bias network even though the amplifier uses a single-polarity power supply. U2's averaged pulses keep the output of U3A at 5 to 6

volts with normal noise input from the receiver. R17, which sets U2's period, can be varied to keep U3A's quiescent output voltage near the center of its range.

On very quiet channels there may not be enough pulses from U2 to keep U3A properly biased. False detects may occur as U3A's output goes in and out of its linear range. You can inject extra noise or low-level tone into the squelch circuit's auxiliary input to achieve the desired results for your particular application.

U3A's output is ac-coupled to U3B, which amplifies with a gain of 2, and thence to U3C, a unity-gain inverter. U3B and U3C together form a phase splitter with a gain of 2. The phase



splitter provides positive-going outputs for positive and negative frequency deviations of the receiver audio.

Comparators U4A and U4B detect the rate-of-change-of-frequency signals from the phase-splitter outputs. If the voltage at the inverting (-) input of U4A or U4B exceeds the reference voltage set by squelch-threshold control R30, then the low-going level at the comparators' paralleled open-collector outputs discharges C20 through R34 and D1. The discharge time constant is 10 milliseconds. C20, R35, and comparator U4C form a time-delay circuit which holds squelch open during its one-second period. Each detector output longer than

10 milliseconds resets the timer for another one second. R35 controls length of delay.

U4C's output is the squelch-open signal (active high). U4C turns on hysteresis-switch transistor Q1 (which lights LED2) and activates output-driver U4D. As shown, U4D's output goes high to unsquelch. We used normally-closed relay contacts so that the speaker is enabled when the relay is turned off or if power is removed from the squelch circuit. To reverse the sense of the output, exchange the (+) and (-) inputs of U4D. (Jumpers are provided on the PC board.) U4D's open-collector output can drive a relay in the speaker lead, as shown, or a gated amplifier, optoisolator,

or TTL or CMOS logic circuit. The comparator output can sink 50 mA maximum.

The squelch is more sensitive after opening than before. The sensitivity change is called *hysteresis*. With no hysteresis, the squelch may drop out while someone is

talking. If there is too much hysteresis, squelch threshold becomes hard to adjust properly. Detector comparators U4A and U4B have two levels of hysteresis. Positive-feedback resistor R32 prevents comparator oscillation and lowers the threshold slightly during a

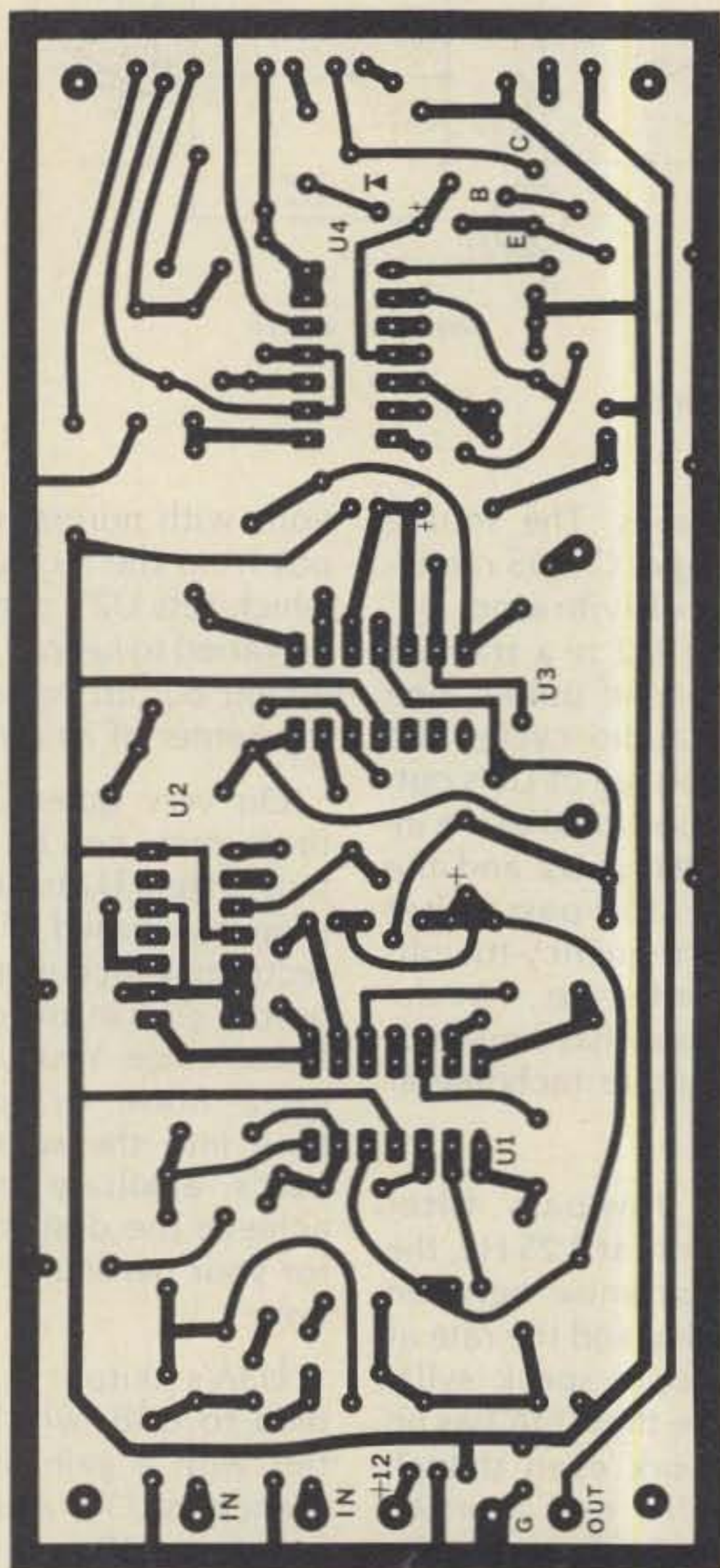

Fig. 2. PC board (foil side).

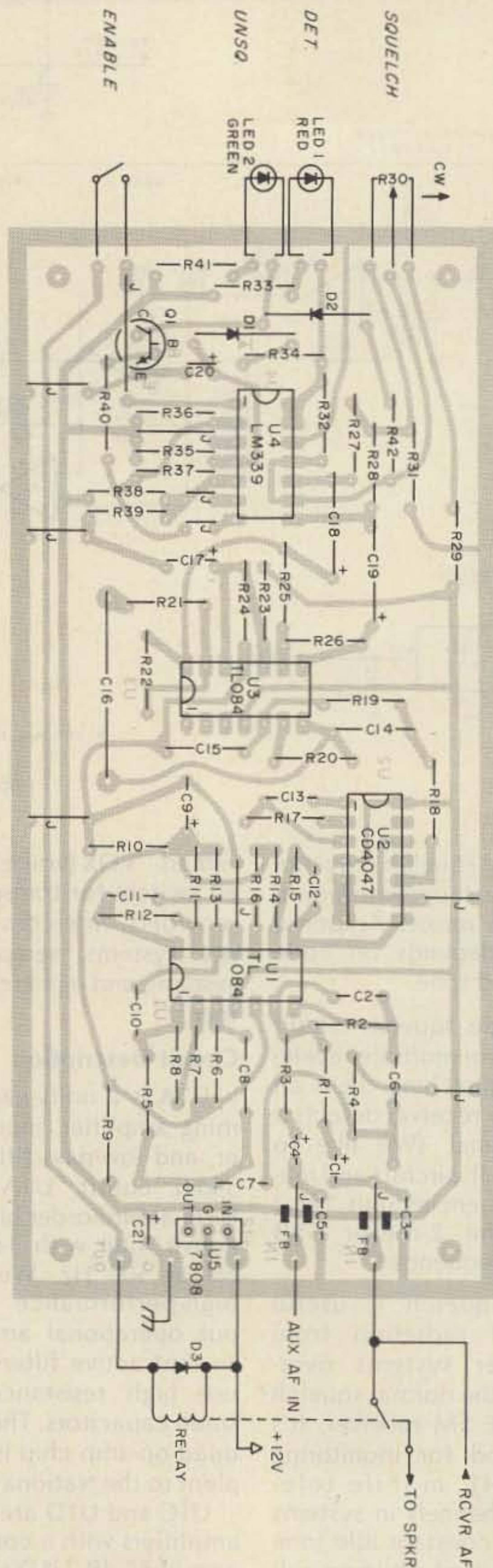

Fig. 3. Component layout.



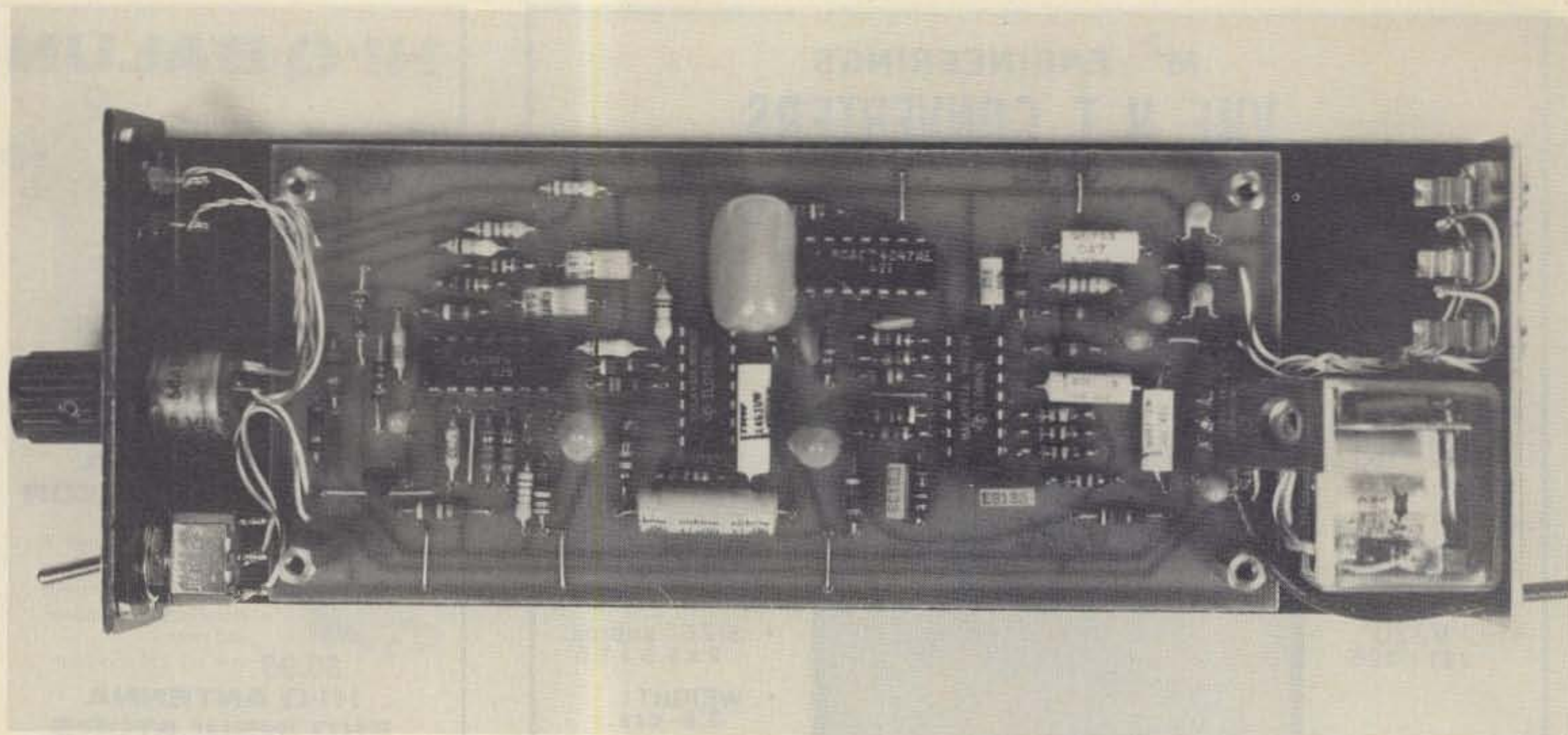

Photo B. Circuit board and chassis detail. The only external connections required are receiver audio, speaker, and 12 volts dc. (Photo by KA9FJS)

detect. Q1 conducts while squelch is open, further reducing the threshold voltage via R42 and D2. R42 determines the amount of hysteresis. The 100k value shown for R42 provides smooth squelch operation.

The circuit uses 25-30 mA plus relay current. The eight-volt-regulator IC, U5,

should be used for mobile operation. Otherwise, the entire circuit can run from a well-regulated 12-volt supply. (Omit U5 and add a jumper between input and output pins of U5 on the PC board.)

#### Adjustment

LED1 lights whenever the

detector is active. Listen to a voice signal and adjust the threshold control until LED1 blinks for every spoken syllable, then make fine adjustments as necessary for noise conditions. The enable switch allows you to adjust the squelch before activating the relay and allows you to unsquelch with-

out disturbing the threshold setting. Scale markings around the control knob make it easier to reset an often-used level.

#### Construction

All-new parts cost about \$40, using referenced items from Radio Shack and ECG. Resourceful hams can build

#### Parts List

##### Semiconductors

U1, U3	TL084C quad BIFET op amp	2	\$ 5.98
U2	CD4047 CMOS multivibrator (ECG 4047)	1	1.49
U4	LM339 quad comparator	1	1.50
U5	7808 8-volt regulator (optional—see text)	1	.99
Q1	2N2222 or equiv. silicon NPN transistor	1	.15
D1, D2	1N914 or equiv. silicon diode	2	.20
D3	1N4002 or equiv. silicon diode	1	.10
LED1	Red LED (rectangular)	1	.49
LED2	Green LED (rectangular)	1	.49

##### Capacitors (All 20 V or more)

C12	68 pF	1	.12
C3, C5, C13	1000 pF	3	.45
C7, C8	4700 pF, 5%	2	.60
C6	0.047 uF, 5%	1	.30
C2	0.056 uF	1	.30
C10, C11	0.1 uF	2	.30
C15	0.22 uF, 5%	1	.40
C14	0.47 uF, 5%	1	.40
C1, C4, C20, C21	1 uF, electrolytic	4	1.60
C16	4.7 uF, non-polarized (RS 272-998)	1	.99
C18, C19	6 uF, electrolytic	2	2.36
C9, C17	47 uF, electrolytic	2	2.00

##### Resistors (All 1/4 Watt; \* = 5%)

R1, R2, R3, R33, R41	1k	5	
----------------------	----	---	--

R11, R14	2.7k	2
R9, R10, R23, R24	4.7k	4
R4*, R31	6.8k	2
R30	5k, linear pot	1
R13, R16, R34, R36	10k	4
R29	18k	1
R40	47k	1
R38	56k	1
R5*, R6*, R7, R8, R21	68k	5
R25, R26, R39, R42	100k	4
R22, R27, R28	130k	3
R18*, R19*	150k	2
R17	160k (see text)	1
R20	300k	1
R12, R15	360k	2
R35, R37	1M	2
R32	2.4M	1

42 @ \$.08 ea. = \$3.28

##### Other

Ferrite beads	2	.10
Miniature earphone jacks	3	1.29
Relay, 12-volt SPDT (RS 275-003)	1	2.99
Switch, miniature toggle SPST	1	1.49
Control knob	1	.49
Hardware, PC board, chassis		10.00

Parts Total \$40.85



# HAL'S SUMMER SPECIALS

**HAL 2304 MHz DOWN CONVERTERS (FREQ. RANGE 2000/2500 MHz)**  
2304 MODEL #1 KIT BASIC UNIT W/PREAMP LESS HOUSING & FITTINGS ..... \$34.95  
2304 MODEL #2 KIT (with preamp) ..... \$44.95  
2304 MODEL #3 KIT (with High Gain preamp) ..... \$54.95

MODELS 2 & 3 WITH COAX FITTINGS IN & OUT AND WITH WEATHER-PROOFED DIE CAST HOUSINGS  
BASIC POWER SUPPLY ..... \$19.95  
POWER SUPPLY KIT FOR ABOVE WITH CASE ..... \$24.95  
FACTORY WIRED & TESTED ..... \$34.95

ANTENNAS & OTHER ACCESSORIES AVAILABLE. SEND FOR MORE INFO.

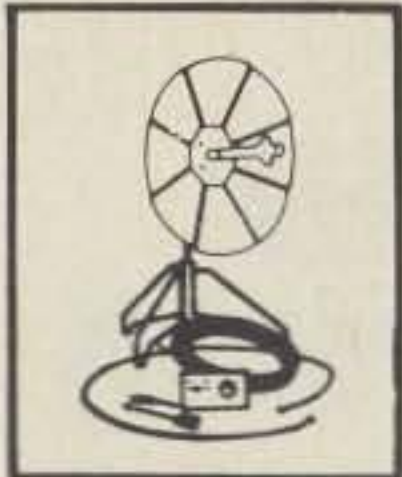

## 2100-2500 MHz

\*HMR-II COMPLETE UNIT  
COMPLETE SYSTEM AS SHOWN. NOT A KIT. INCLUDES A PC BOARD, POWER SUPPLY, CABLES & CONNECTORS—PRE-ASSEMBLED AND TESTED. 24dB GAIN OR GREATER.  
1 UNIT ..... \$149.95  
2 UNITS ..... \$139.95 ea.  
3 OR MORE UNITS ..... \$129.95 ea.

\*HAM MICROWAVE RECEIVER

## PRE-SCALER KITS

HAL 300 PRE (Pre-drilled G-10 board and all components) ..... \$14.95  
HAL 300 A/PRE (Same as above but with preamp) ..... \$24.95  
HAL 600 PRE (Pre-drilled G-10 board and all components) ..... \$29.95  
HAL 600 A/PRE (same as above but with preamp) ..... \$39.95

## TOUCH TONE DECODER KIT

HIGHLY STABLE DECODER KIT. COMES WITH 2 SIDED, PLATED THRU AND SOLDER FLOWED G-10 PC BOARD, 7-567s, 2-7402, AND ALL ELECTRONIC COMPONENTS. BOARD MEASURES 3-1/2 x 5-1/2 INCHES. HAS 12 LINES OUT. ONLY \$39.95

NEW—16 LINE DELUXE DECODER ..... \$69.95  
DELUXE 12-BUTTON TOUCHTONE ENCODER KIT UTILIZING THE NEW ICM 7206 CHIP PROVIDES BOTH VISUAL AND AUDIO INDICATIONS! COMES WITH ITS OWN TWO-TONE ANODIZED ALUMINUM CABINET MEASURES ONLY 2 3/4" x 3 3/4". COMPLETE WITH TOUCH-TONE PAD, BOARD, CRYSTAL CHIP AND ALL NECESSARY COMPONENTS TO FINISH THE KIT. PRICED AT \$29.95  
NEW—16 LINE DELUXE ENCODER ..... \$39.95  
HAL ECD—16 LINE DELUXE ENCODER INCLUDES PC BOARD, ALL PARTS & CASE ..... \$39.95

HAL ECD—12 LINE DELUXE ENCODER COMPLETE WITH PC BOARD, ALL PARTS & CASE ..... \$29.95

ACCUKEYER (KIT) THIS ACCUKEYER IS A REVISED VERSION OF THE VERY POPULAR WB4VVF ACCUKEYER ORIGINALLY DESCRIBED BY JAMES GARRETT, IN QST MAGAZINE AND THE 1975 RADIO AMATEUR'S HANDBOOK. \$16.95

ACCUKEYER—MEMORY OPTION KIT PROVIDES A SIMPLE, LOW COST METHOD OF ADDING MEMORY CAPABILITY TO THE WB4VVF ACCUKEYER, WHILE DESIGNED FOR DIRECT ATTACHMENT TO THE ABOVE ACCUKEYER, IT CAN ALSO BE ATTACHED TO ANY STANDARD ACCUKEYER BOARD WITH LITTLE DIFFICULTY. \$16.95

BUY BOTH THE MEMORY AND THE KEYS AND SAVE COMBINED PRICE ONLY \$32.00

## PRE-AMPLIFIER

HAL-PA-19 WIDE BAND PRE-AMPLIFIER, 2-200 MHz BANDWIDTH (-3dB POINTS), 19 dB GAIN  
FULLY ASSEMBLED AND TESTED ..... \$8.95

HAL-PA-1.4 WIDE BAND PRE-AMPLIFIER, 10 MHz TO 1.4 GHz, 12dB GAIN  
FULLY ASSEMBLED ..... \$12.95



**CLOCK KIT—HAL 79 FOUR-DIGIT SPECIAL—\$7.95. OP.**  
ERATES ON 12-VOLT AC (NOT SUPPLIED) PROVISIONS FOR DC AND ALARM OPERATION.

## 6-DIGIT CLOCK • 12/24 HOUR

COMPLETE KIT CONSISTING OF 2 PC G-10 PRE-DRILLED PC BOARDS, 1 CLOCK CHIP, 6 FND COMM. CATH. READOUTS, 13 TRANS., 3 CAPS, 9 RESISTORS, 5 DIODES, 3 PUSH-BUTTON SWITCHES, POWER TRANSFORMER AND INSTRUCTIONS. DON'T BE FOOLED BY PARTIAL KITS WHERE YOU HAVE TO BUY EVERYTHING EXTRA. PRICED AT \$12.95

CLOCK CASE AVAILABLE AND WILL FIT ANY ONE OF THE ABOVE CLOCKS. REGULAR PRICE. . . \$6.50 BUT ONLY \$4.50 WHEN BOUGHT WITH CLOCK.

SIX-DIGIT ALARM CLOCK KIT FOR HOME, CAMPER, RV, OR FIELD-DAY USE. OPERATES ON 12-VOLT AC OR DC, AND HAS ITS OWN 60-Hz TIME BASE ON THE BOARD. COMPLETE WITH ALL ELECTRONIC COMPONENTS AND TWO-PIECE, PRE-DRILLED PC BOARDS, BOARD SIZE 4" x 3". COMPLETE WITH SPEAKER AND SWITCHES. IF OPERATED ON DC, THERE IS NOTHING MORE TO BUY\*  
PRICED AT \$16.95

\*TWELVE-VOLT AC LINE CORD FOR THOSE WHO WISH TO OPERATE THE CLOCK FROM 110-VOLT AC  
WHEN PURCHASED WITH CLOCK KIT \$2.95

SHIPPING INFORMATION: ORDERS OVER \$25 WILL BE SHIPPED POST-PAID EXCEPT ON ITEMS WHERE ADDITIONAL CHARGES ARE REQUESTED. ON ORDERS LESS THAN \$25, PLEASE INCLUDE ADDITIONAL \$2.00 FOR HANDLING AND MAILING CHARGES. SEND 20c STAMP FOR FREE FLYER.

DISTRIBUTOR FOR  
Aluma Tower-AP Products  
(We have the new Hobby-Blox System)

## HAL-TRONIX

P. O. BOX 1101  
SOUTHGATE, MICH. 48195  
PHONE (313) 285-1782

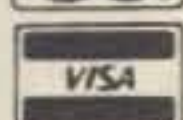

"HAL" HAROLD C. NOWLAND  
WBZ XH

the circuit for substantially less.

We built several prototypes on universal printed-circuit cards. The only critical area is U1, where high limiter-amplifier gain can cause feedback oscillation in some layouts. Keep component leads as short as possible. Use 5% tolerance or better for frequency-determining components in active filters. The Radio Shack relay's frame must be insulated from ground. Mounting the relay on a rubber pad quiets its clicking and isolates it from vibration.

## Conclusion

Although squelch effectiveness may diminish on very crowded amateur bands, a sensitive, discriminating squelch is very useful for net operations and scheduled contacts, especially with modern digitally-tuned receivers which

can be preset to precise frequencies.

This circuit can be a starting point for many experiments. You could, for example, insert an analog delay device between audio input and output. If the delay were longer than the squelch response time, then squelch would open *before* the first spoken syllable reaches the loudspeaker.

Digital techniques could perform the function of the analog circuit described here, perhaps with improvements such as adaptive threshold and program-controlled time constants. We are experimenting with a microprocessor-based voice detector which may be the subject of a future 73 article. ■

## References

<sup>1</sup>Don Lancaster, *Active Filter Cookbook*, Howard W. Sams & Co., Inc., 1975.

<sup>2</sup>Motorola *Micom HF SSB Transceiver Service Manual*, 1975.

# CALL LETTER HATS



## HATS

ONLY \$5

DISTRIBUTED BY  
**TUFTS ELECTRONICS**  
61 Lowell Road  
Hudson, NH 03051

603-883-5005

Attractive and Durable. These Non-Run Imprints Can Express Your Message.  
Hats Are One Size Fits All w/Nylon Mesh Back

LINE 1  Morsekey  My Own Logo

LINE 2

LINE 3

Or

CIRCLE ONE  
Red Royal Blue Kelly Green



Introduced and the talk of the Dayton Hamfest these Attractive and Durable CALL LETTER HATS are just the thing for Hamfests, Field day, Contests and other Club Activities. Messages are printed by computer and can be up to three large lines or six small lines of copy. For orders of 12 or more hats deduct 10% and the club or business logo will be FREE. Phone orders shipped in one day, two days for special logo orders. Provide a good b&w copy of your logo.

Name \_\_\_\_\_ Phone \_\_\_\_\_

Address \_\_\_\_\_

City \_\_\_\_\_ State \_\_\_\_\_ Zip \_\_\_\_\_

Ck  Money Order  Charge Card  # \_\_\_\_\_

Signature To Validate Order \_\_\_\_\_ Exp. Date \_\_\_\_\_

ORDER BLANK  Add \$2 To Total For Shipping Charges