

**Introduction**

Congratulations on purchasing the MFJ-224 2-Meter FM Analyzer. With this versatile handheld instrument, you can tune in any signal between 143.5 and 148.5 MHz to monitor field strength in dBm and FM-deviation in kHz. Accurate tuning is made simple, thanks to the built-in discriminator-meter function. Battery status is also displayed. In addition to metered functions, the MFJ-224 lets you visually analyze modulation waveforms and measure instantaneous-peak deviation by plugging into an oscilloscope. Finally, a headphone monitor circuit helps you tune in and identify signals easily. Before exploring the MFJ-224's many uses, please take a few minutes to read this manual. A special orientation section is provided to help you get started.

**Technical Specifications**

|                                 |   |
|---------------------------------|---|
| Frequency Coverage .....        | 143.5 - 148.5 MHz                                 |
| Selectivity .....               | -6 dB @ 20 kHz                                    |
| Receiver Type .....             | Dual Conversion, 10.7 MHz 1st IF, 455 kHz 2nd IF  |
| Oscilloscope Output .....       | 1 V p-p for 1-kHz tone at 5-kHz deviation         |
| Phone Jack Output .....         | Lo-Z, preset volume level                         |
| RSSI Range .....                | -100 dBm to -40 dBm (60-dB range)                 |
| Deviation Range .....           | 0-7 kHz on Meter, 0-20 kHz on scope (1-kHz tone). |
| Discriminator Meter Range ..... | +/- 3 kHz, Zero-centered                          |
| Operating Voltage .....         | 6.5 - 9.0 Volts DC                                |
| Power Source .....              | 9-Volt rectangular alkaline battery               |

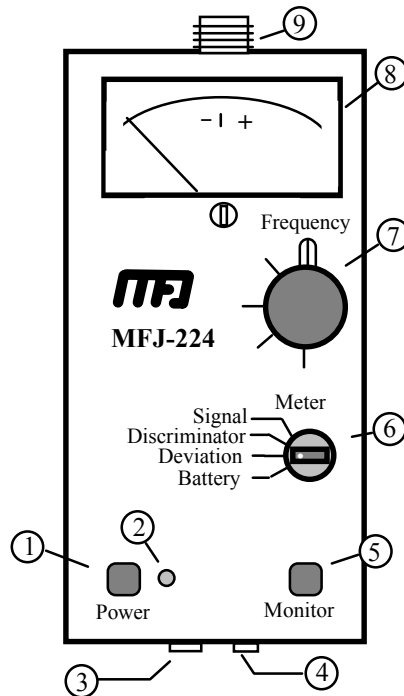

**Controls and Jacks**

1. Power Off/On Switch
2. Power "On" LED
3. Oscilloscope Output (RCA)
4. Headphone Jack (3.5mm)
5. Headphone Monitor "on" switch
6. Meter Function Switch
7. Tuning Knob--Frequency
8. Meter, 3" Precision Movement
9. Antenna Connector (SO-238)

## What Your Meter Can Do

The MFJ-224 performs countless jobs around the shop or radio shack. Here are some uses we think you'll appreciate:

- **Evaluate Antenna Performance:** Measure key yagi specifications such as *gain over a dipole* (dBd), *beamwidth* (-3dB points), *front-to-back ratio*, and *sidelobe suppression*. You can compare antennas to see which works best, and check the real-world performance of experimental antennas against NEC-based computer predictions.
- **Detect Feedline Faults:** Document end-to-end cable loss in dB. Find out if kinks, corrosion, and moisture have deteriorated performance--or discover if a new feedline meets factory specs. See how much signal is actually lost between the antenna and radio.
- **Map Repeater Field-strength:** Plot repeater or packet-node field strength in dBm or microvolts throughout the coverage area. Find out where the signal is going--and where it isn't. Evaluate the impact of site changes with accuracy.
- **Site your Antennas:** Take the MFJ-224 to the mountain, on the roof, or up the tower to position antennas for best performance (a few feet either way can make a big difference over difficult paths). Aim yagis with absolute pin-point accuracy.
- **Measure Preamp Gain:** Tune preamps for best gain and noise figure using your meter, a scope, and a weak signal source. Measures *exact gain* in dB.
- **Fox Hunt:** Track down hidden transmitters--or nail jammers fast! High resolution 60-dB RSSI display is amateur radio's most accurate S-meter.
- **Check and Set Deviation:** Measure transmitter deviation anywhere in the band. Use the built-in meter display with a test-tone, or plug into a scope for accurate instantaneous-peak readings on speech, packet, DTMF, and CTCSS tones. Help your fellow hams--the MFJ-224 can measure the deviation of any signal you can hear off-air!
- **Analyze Audio Quality:** Use the oscilloscope output to visually evaluate the quality of speech or tones by viewing the audio waveform. See if tones are clipped or distorted, if the speech limiter is working improperly, etc. Solve FM audio problems fast!
- **Scan the Band:** Tune in and identify signals using monaural or stereo Lo-Z headphones. Check speech quality of your radios or use as a second receiver to monitor activity.
- **Tune Transmitters and Filters:** Use with RF-sniffer probe to tune low-power transmitter stages. Tune high-Q filters and networks for best response, lowest loss.

## How Your Meter Works

A Motorola FM-receiver IC with logarithmic RSSI metering circuitry measures signal strength over a 60-dB dynamic range. This allows input levels from -100 dBm to -40 dBm to be displayed on a linear meter scale with 1-dB resolution. In addition to providing accurate RSSI, the IC features a built-in tunable oscillator--plus outputs to drive the FM-deviation detector, headphone monitor circuit, and a discriminator tuning meter. The block diagram below illustrates how the MFJ-224 is organized:

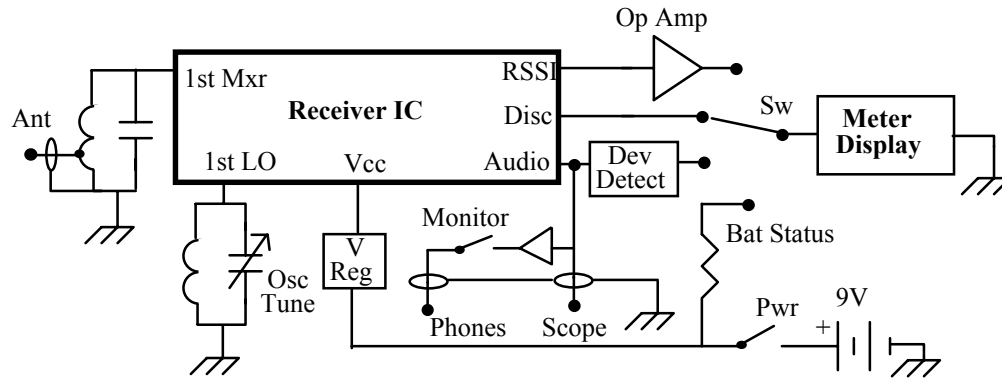

Detailed operating instructions will help you understand how each feature works--and how to get the most from your meter..

## Battery Installation

Before using your meter for the first time, you must install a fresh 9-volt battery. The MFJ-224 draws about 20 mA when in use, and can operate for many hours between battery changes. However, we suggest you check *battery status* each time you turn the unit on. The MFJ-224 is voltage regulated, and battery voltage may drop as low as 7-volts before operation becomes erratic. When purchasing a battery, be sure to select a premium-quality alkaline type--such as Duracell MN1604, Eveready 522, Ray-O-Vac A-1604, or Radio Shack 23-553.

Begin installation by removing the mounting screws from both side panels of the meter case. Gently separate the front and back sections, taking care not to pull on the antenna lead or battery wires. If replacing a spent alkaline battery, dispose of it in a prescribed manner. To install the new battery, snap on the 9-volt connector and press the case *firmly* into the retainer clip (make sure it can't pop loose). Now, re-assemble the case.

***IMPORTANT NOTE:*** *To protect your unit from damage due to battery leakage, remove the battery when storing for prolonged periods.*

## **Orientation--Hooking Up Your Meter**

To become familiar with the various features and functions of your MFJ-224, connect it up as shown below (if you lack an oscilloscope, omit that portion of the orientation).

**1. Headphones:** You'll need a pair of low-impedance headphones outfitted with a 3.5 mm (1/8") plug. Without phones, you will be unable to identify signals and tune them in properly. The headphone circuit is configured to work with either stereo or monaural plugs and wiring, but a pair of good-quality stereo phones work best. Headphone audio level is pre-set to a low-but-comfortable listening level.

**2. Antenna:** The MFJ-224 accepts any 50Ω source outfitted with a UHF connector. Avoid directly-connecting RF levels exceeding -20 dBm (.03 volts) to the meter. To sample stronger sources, use a pick-up probe or resistive attenuator. For the purpose of this orientation, connect a 2-Meter station antenna to monitor off-air signals.

***IMPORTANT NOTE:*** *Your MFJ-224 is a sensitive instrument. To avoid damage, never connect a transmitter or powerful RF oscillator directly to the antenna jack.*

**3. Oscilloscope:** Connecting a scope to the MFJ-224 enhances its value as a deviation meter and audio analyzer. Since only audio frequencies are monitored, any general-purpose scope will have sufficient frequency response. However, a well-calibrated unit will yield more accurate deviation readings. Connect your meter to the scope's vertical-amplifier input using shielded cable. To begin, set the sweep for .5 mS and vertical gain for 0.2 volts per division. A 1-kHz test-tone modulating a FM transmitter to 5-kHz of deviation normally produces a sine-wave output of about 1.0 volts p-p.

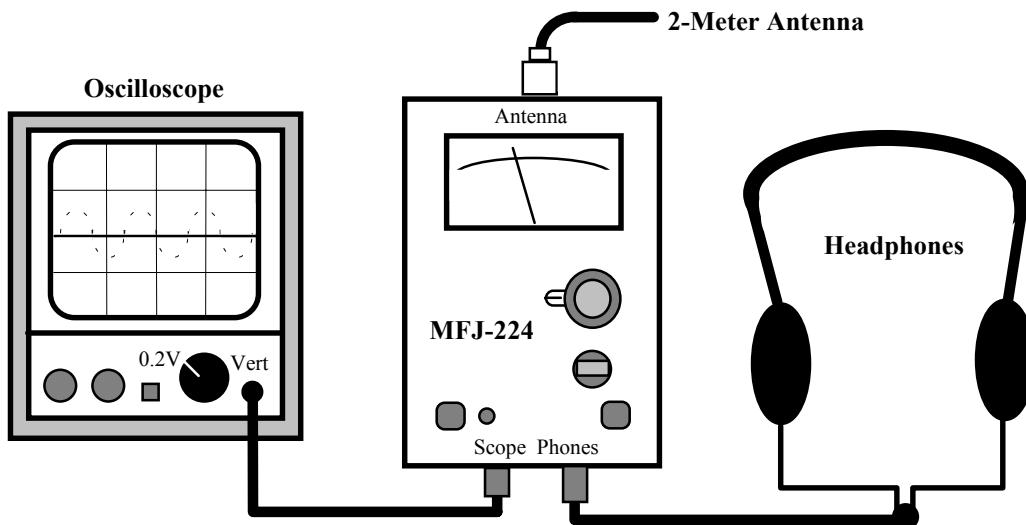

You are now ready to explore the basic features and functions of the MFJ-224.

## Orientation--Learning To Use Your Meter

- 1. Power On:** To power-up your unit, depress the *power* switch. The green pilot LED should illuminate.
- 2. Battery Status:** To check battery condition, turn the meter selector switch to *battery* and note the indication. The meter should swing into the *good* zone of the scale.
- 3. Headphone Monitor Switch:** To monitor signals, plug in headphones and depress the *monitor* switch. You should hear a strong background hiss. This is FM-receiver noise.
- 4. Tuning:** The *Frequency* (variable frequency oscillator) control tunes the meter's FM receiver. Use the vernier-reduction tuning knob to scan across the band for active repeaters in your area. These will provide sample signals for you to analyze.

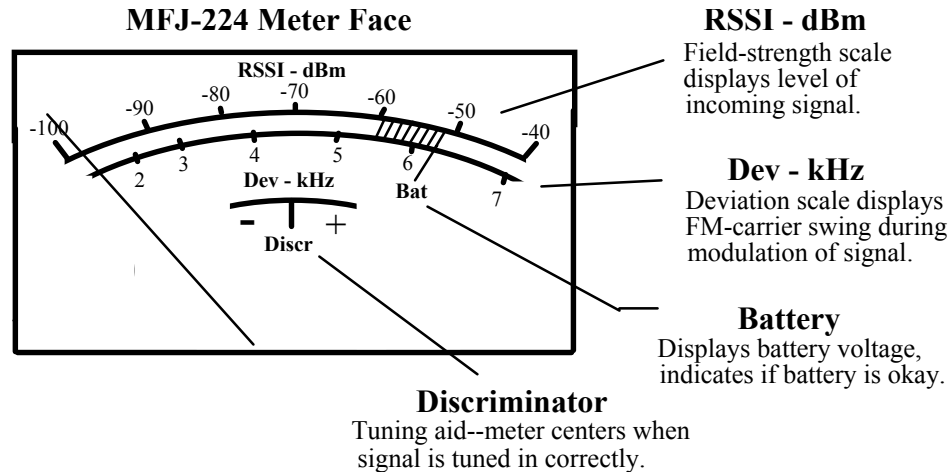

**5. Discriminator Meter Function:** Turn the meter selector to *discriminator*. This function is a tuning aid to help you zero-in signals before making measurements. Accurate tuning is important because readings taken while the receiver is mistune-tuned may be incorrect. The discriminator meter normally hovers around center-scale with no station present--then deflects sharply as you tune across a signal. Practice tuning stations for a *center-scale meter reading*. The indicator is *very* sensitive, and tuning "dead on" may take some practice!

**6. Signal Meter Function:** The *Signal*, or *RSSI (Recovered Signal Strength Indicator)* function, displays incoming signal strength. The meter scale is calibrated in dBm, a unit of RF power (0 dBm = 1 mW @ 50-Ω). The dBm unit is especially convenient because it may be used for making signal-level comparisons directly in dB. Note that it is normal

for the meter to read below -100 dBm with no signal present. Check the repeater signals in your area and note the level differences between them in dB!

**7. Deviation Function:** Use the *deviation* function to check transmitter modulation. The 0-7 kHz scale on the meter is accurate *only* when a continuous audio or packet calibration tone is applied to the transmitter under test. However, you can get a pretty good idea who's over-deviating and who's not by watching meter movement on normal speech. For a better look at deviation, turn on your oscilloscope. This provides an accurate display for *any* type of modulation--from normal speech or AFSK, to CTCSS and DTMF tones. Use the chart on page 10 to convert from *peak-to-peak voltage* to *deviation in kHz*.

Now that you've mastered the basics of meter operation, the next section will cover some specific tips and useful data to help you get the most from your meter.

### **Field-Strength Measurements**

**1. dBm, dB, and uV:** The *Signal* (or RSSI) meter scale is calibrated in dBm, a unit of RF power. As previously mentioned, calibrating the scale in dBm is convenient because it allows comparison of signal *differences* directly in dB. Signal strength is also commonly expressed in uV (or microvolts). This is a unit of RF voltage. The following chart may be used to convert dBm readings into uV:

| <b>Power in dBm</b> | <b>Microvolts</b> |
|---------------------|-------------------|
| -100 dBm            | 3 uV              |
| -90 dBm             | 10 uV             |
| -80 dBm             | 30 uV             |
| -70 dBm             | 100 uV            |
| -60 dBm             | 300 uV            |
| -50 dBm             | 1000 uV           |
| -40 dBm             | 3000 uV           |

**2. Field-strength Measurements:** When mapping field strength, you'll find it helpful to use a portable yagi rather than a dipole or omnidirectional antenna. The yagi reduces measurement errors due to *multi-path interference* (signals reflected from hills, buildings, etc.). To compensate dBm meter readings for yagi gain, use the following formula:

$$\text{RSSI Reading in dBm} - \text{Antenna Gain in dBd}^* = \text{Field Strength}$$

\*dBd means gain compared to a 1/2-wave dipole. If yagi gain is given in dBi (dB compared to an isotropic source), be sure to subtract 2.14 dB from this figure to get dBd. For example, a yagi with 8.14 dBi gain will exhibit 6.00 dBd gain over a dipole.

**3. Comparing Antenna Performance:** The *Signal* display is useful for comparing two or more antennas for best performance. In most cases, a local repeater may be used as a signal source. These results can be extremely accurate, but only if steps are taken to prevent error. Here is a list of tips for getting good results:

- [ ] Position each antenna at the same exact location and height (one at a time).
- [ ] Mount antennas at least 15 feet above ground--away from other objects or feedlines.
- [ ] Find a spot where the signal is stable, avoiding nulls or multipath-prone locations.
- [ ] Watch for minor signal-level drifting (1-2 dB) due to propagation enhancements.
- [ ] Use identical coax feeds and the same type of mast for each antenna under test.
- [ ] Fully decouple each antenna from its feedline to prevent stray pickup.
- [ ] Change antennas quickly, and keep other test antennas out of the way.
- [ ] Repeat tests to confirm that your data will hold up under repetitive trials.

If you use a locally-generated signal source, place it--at minimum--several wavelengths down-range (out of the antenna's near field). Also, use the same antenna height and polarization as the antenna under test.

**4. Yagi Performance:** The *Signal* function can tell you a great deal about the performance of directional antennas such as quads and yagis. To test these, you'll need a compass rose at the base of your mast--or a rotator with a control box--so you can document degrees of rotation off-axis from the signal source. The primary specifications for directional antennas are:

**Forward Gain (dBd):** How much advantage does your directional antenna provide over a 1/2-wave dipole? To find out, use the comparison techniques outlined above. The directional antenna should be pointed at the source, and the dipole aligned broadside. Your reference dipole should be properly matched and fully decoupled from its feedline by a balun or by ferrite beads. Note that gain figures will change with frequency.

**Beamwidth:** How broad is your antenna pattern? To find out, aim it at the signal source and rotate until the RSSI meter drops by 3 dB (the antenna's *half-power point*). Now, rotate the opposite way--through the peak--until it again drops by 3 dB. The degrees of rotation between -3 dB points is called the *beamwidth*. Generally, wide-beamwidth antennas have less gain and narrow-beamwidth antennas have more gain.

**Front-to-Back Ratio:** How well does your antenna reject signals off its back side? To measure *front-to-back ratio*, first point your antenna at the signal source and record the RSSI reading. Then, swing the antenna 180-degrees and record the back reading. The difference in dBm is the front-to-back ratio in dB. These days, the term "Front-To-Rear" ratio is also commonly used. This represents an *average* of several back-readings taken over a span of 30 degrees. Many designers feel that Front-To-Rear Ratio provides a more accurate picture of the antenna's true performance.



**Sidelobe Suppression:** Sidelobes are "peaks" in antenna response that occur off the side of a directional antenna. A well-designed yagi will have a clean well-defined pattern with only a few weak sidelobes. However, a poorly-designed yagi may have several strong peaks off to the side. If your yagi has a sidelobe problem, you can spot it easily on the RSSI display as you rotate the antenna. However--beware of multipath reflections--they can *look* like sidelobes in hilly or built-up locations!

Characteristics of a Typical Yagi Directional Antenna

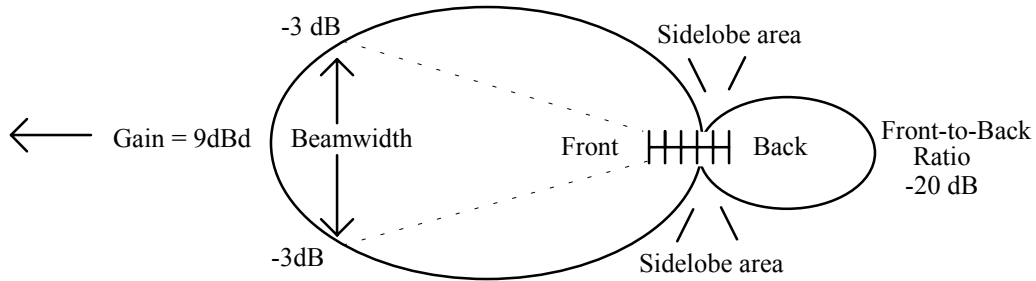

**5. Coaxial Line Loss:** The *Signal* (RSSI) function, when used in conjunction with a signal generator, can provide accurate end-to-end loss measurements for 50Ω coaxial line. With this test, you can determine how much signal is being attenuated between the antenna and radio--or check feedlines for signs of deterioration. To do this, first measure the output level of your signal generator through a short patch cable. Then, replace the patch cable with the length of feedline you wish to test--and measure again. The difference between the two RSSI readings will be the *measured loss* in dB for your cable.

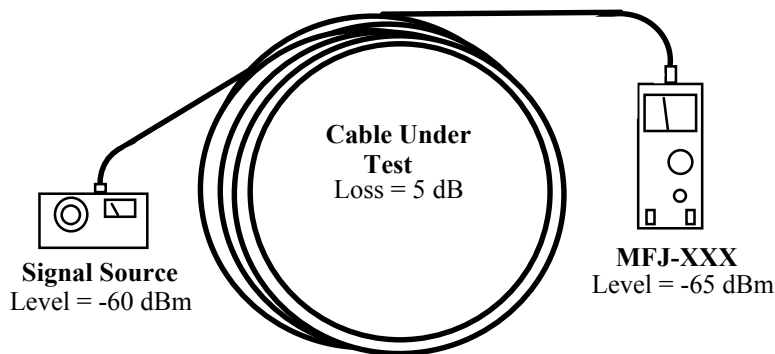

$$\text{Measured Loss} = \text{Signal at Generator} - \text{Signal at Cable Far End}$$

**Example:** If a signal generator is set for -60 dBm output and delivers -65 dBm to the far end of a cable, the *measured loss* is 5 dB.

## **Measuring Deviation**

*Deviation* is the amount of carrier-shift used by FM transmitters to convey speech or data. For more information about how frequency modulation works, consult a current edition of *The ARRL Handbook for Radio Amateurs*. The FM reference will provide a useful theoretical background for this popular mode.

Controlling deviation is important. Too much of it will cause interference on adjacent channels, and too little will result in poor speech intelligibility or failure to connect. As a rule of thumb, deviation on the 2-Meter amateur band should *never* exceed 5 kHz. Generally, the following modulation levels are prescribed for 2-Meter amateur service:

| <b>Mode</b> | <b>Deviation Level</b>    |
|-------------|---------------------------|
| Speech      | 3 kHz average, 5 kHz peak |
| Packet      | 3 kHz continuous          |
| CTCSS       | 0.6 kHz superimposed tone |

**1. Preparing for Deviation Adjustments:** Deviation adjustments are normally made with a continuous 1-kHz sinewave applied to the microphone jack using an AF signal generator. For packet, these adjustments are made using the TNC's built-in *calibrate* function. When adjusting FM transceivers, study all relevant service documents carefully and follow the manufacturer's instructions closely.

The MFJ-224 is a sensitive instrument and you must take care not to overload it during transmitter deviation tests. To limit ambient RF levels in the test area, terminate the transmitter under test with a shielded 50Ω dummy load. Also, use the *minimum* amount of antenna pick-up required to obtain a good signal sample on your meter (*never* connect a transmitter directly to the meter). Levels around -60 to -70 dBm RSSI will provide a clean noise-free signal for evaluation. Tune the transmitter signal in carefully, observing the discriminator meter for centering. Also, check the discriminator meter periodically during tests and correct any receiver drift.

**2. Deviation Readout on the Meter:** The meter displays deviation for any continuously-modulated FM signal between 2 and 7 kHz. As mentioned earlier, a 1-kHz tone or packet calibration tone should be applied to the transmitter under test. The meter cannot be used to set CTCSS tones because it cannot register deviation accurately below 2 kHz (you must use a scope).

***IMPORTANT NOTE: It is normal for the deviation meter to deflect full scale when no signal is being received. This is due to FM limiter noise. Also, the deviation level on weak signals way read somewhat higher due to noise contribution. Make sure signals are "full quieting" when measuring deviation.***

**3. Deviation Readout with an Oscilloscope:** Checking deviation with a scope provides an *instantaneous peak* display of modulation level. This means you can look at speech waveforms and estimate deviation with reasonable accuracy--something not possible using the meter scale. Also, low-level signals such as PL-tones (CTCSS) are set easily using the scope display. Finally, audio problems such as overload distortion, non-linearity, or limiter mis-adjustment are easier to spot and diagnose on a CRT display. To measure deviation with your scope, use the voltage chart provided below. A sweep rate of .5 mS and a vertical amplifier sensitivity of .2V (200 mV) per division is recommended for adjustments up to 5 kHz.

***IMPORTANT NOTE:*** *When measuring deviation on a scope, set the MFJ-224 Meter Switch to either the Battery or Signal position. This will prevent the metering circuits from loading down the signal being fed to your scope. Scope readings taken with the meter switch in the Discriminator or Deviation position may be somewhat reduced in amplitude--and will not conform to the calibration chart shown below:*

| <u>Voltage p-p</u> | <u>kHz Deviation</u>          |
|--------------------|-------------------------------|
| 0.12               | 0.6 (CTSS levels)             |
| 0.2                | 1                             |
| 0.4                | 2                             |
| 0.6                | 3 (Packet Calibration Tone)   |
| 0.8                | 4                             |
| 1.0                | 5 (1-kHz tone or Peak Speech) |
| 1.2                | 6                             |
| 1.4                | 7                             |
| 1.6                | 8                             |
| 1.8                | 9                             |
| 2.0                | 10                            |

It should be noted that this chart provides p-p voltage levels generated by a *typical* MFJ-224 scope-monitor circuit, and minor variations may occur from unit to unit. If you monitor deviation often, it may prove helpful to make up a clear-plastic overlay for your CRT screen calibrated for direct readings in kHz.

**4. Off-air Monitoring:** As a general rule, you will be more successful monitoring off-air deviation using an oscilloscope. Most signals you encounter will consist of speech and short packet bursts, neither of which display accurately on the meter because of its relatively slow response time. Be prepared for an eye-opening experience! Most hams have never measured the FM deviation of their transmitters, and levels often vary widely from station to station!

## **Limitations**

The MFJ-224 is a highly-affordable handheld tester that will help you perform many functions that would otherwise require a sophisticated FM service monitor. However, please keep in mind that it is not a direct replacement for a \$5000 commercial instrument! Here are some of the unit's natural limitations--and some useful tips to help you work around them:

1. The VFO is LC-tuned (not synthesized). Because of this the receiver may be subject to minor frequency drift when exposed to temperature changes or when first turned on. Use the discriminator meter function to ensure accurate tuning before taking readings.
2. The receiver 1st-IF filter at 10.7 MHz is fairly broad. When tuning *extremely strong signals*, the band of "quieting" on either side of center-signal may be wide--making tuning by ear alone somewhat difficult. In this case, use the discriminator meter to locate the exact center of the signal.
3. The MFJ-224 receiver is, by design, approximately 20 dB less sensitive than a typical VHF-FM transceiver (this is done to accommodate bench measurements involving strong transmitter signals). If you must copy extremely weak off-air signals for diagnostic purposes, you may install an external in-line 2-Meter preamplifier to boost sensitivity. Be sure to incorporate preamp gain into your measurements. For example, if your preamp has a measured gain of 20 dB, be sure to subtract this gain from your meter reading. For example, a -90 dBm reading made with a 20dB preamp in-line would indicate an actual input signal strength of -110 dBm ( $-90\text{dB} [-]+20\text{ dBm} = -110\text{ dBm}$ ).

These limitations should not significantly detract from the unit's many overall capabilities.

## **Technical Assistance**

If you have any problem with this unit first check the appropriate section of this manual. If the manual does not reference your problem or your problem is not solved by reading the manual, you may call *MFJ Technical Service* at 601-323-0549 or the *MFJ Factory* at 601-323-5869. You will be best helped if you have your unit, manual and all information on your station handy so you can answer any questions the technicians may ask.

You can also send questions by mail to MFJ Enterprises, Inc., 300 Industrial Park Road, Starkville, MS 39759; by FAX to 601-323-6551; or by email to [mfj@mfjenterprises.com](mailto:mfj@mfjenterprises.com). Send a complete description of your problem, an explanation of exactly how you are using your unit, and a complete description of your station.

## Field Service Guide

The MFJ-224 has several serviceable calibration adjustments. If you lack the necessary equipment or expertise to service sensitive VHF communications equipment, *please do not attempt these adjustments!* Instead, contact a qualified 2-way service technician in your area for assistance or return your unit to the factory for service. To service the unit, remove the screws from the side of the case and separate the front and back sections. The top-side of the circuit board will be exposed for easy access.

- 1. RF Input:** Apply a 146-MHz test signal and adjust L1 for maximum *Signal* reading.
- 2. Frequency Calibration:** Set the *Tuning* dial to 146 MHz and apply a 146-MHz test signal. Adjust L2 so that the test signal is heard at the 146-MHz dial setting.
- 3. Quad-coil Tuning:** Tune to a spot on the dial where no signal is present. Connect a DVM to TP-1 (test point). Tune quad-coil L3 for a reading of 2.45 volts dc.
- 4. Discriminator Meter Zero:** Switch the meter selector to *discriminator* and adjust the *Discriminator Center* trimpot for a center-scale indication with no signal.
- 5. RSSI Calibrate:** Set the meter switch to *Signal (RSSI)*. Using a precision signal generator with calibrated output (HP-8640B or equivalent), apply a -90 dBm signal at 146 MHz. Tune in this signal and adjust the *RSSI Cal* trimpot for a reading of -90 dBm on the meter. Now, increase the generator level to -50 dBm and adjust the *RSSI Range* trimpot for a -50 dBm reading. Repeat this procedure back and forth--until the meter reads accurately at both signal levels. Note that it is normal for the *Signal* meter to read well below -100 dBm when no signal is present.

### Calibration Adjustment Locations-MFJ-224

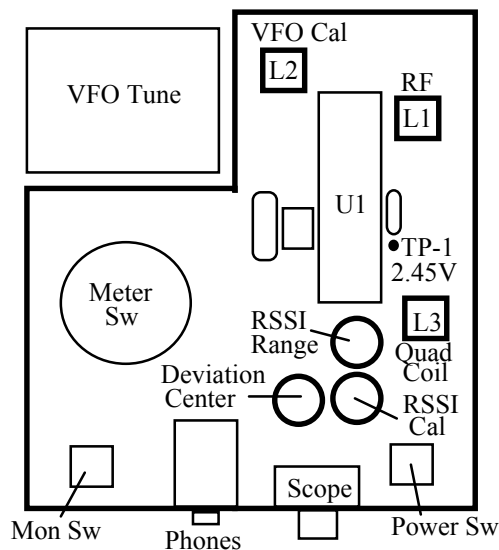

**Schematic**

