

***RLC-2 Software Version 4.28***

***Link Communications Inc.  
P.O. Box 1071  
Sidney, MT 59270-1071***

***<http://www.link-comm.com>***

## *Table of Contents*

Return Policy .....	1-19
<b>Chapter 1: Getting Started</b> .....	<b>1-20</b>
Introduction: .....	1-21
Limited Warranty .....	1-22
User Survey (Optional) .....	1-23
Re-Initialization the Controller .....	1-24
Resetting the Controller .....	1-24
Troubleshooting the Controller .....	1-25
*** Getting On The Air Quickly *** .....	1-26
Setup and Interfacing .....	1-27
Serial Port Interfacing .....	1-32
System Wide Errors .....	1-34
<b>Chapter 2: Port Connection Commands</b> .....	<b>2-1</b>
000: Connect one Port to another Port .....	2-2
001: Monitor one Port from another Port .....	2-3
002: Disconnect one Port from another Port .....	2-4
009: Checking Cross-Point Connections .....	2-5
010: Time-Out Timer Enabled/Disabled .....	2-6
011: Check Time-Out Timer Status .....	2-7
012: Program a Receiver's Access Mode .....	2-8
013: Checking Access Modes .....	2-9
014: Port Supervisory PTT Control .....	2-10

	1-3
015: Check Port Supervisory Control Settings . . . . .	2-11
018: Receiver Active - Inactive Control Command Execution . . . . .	2-12
019: Check Receiver Active - Inactive Command Execution . . . . .	2-13
024: Controls a Port's COR/PL Polarity . . . . .	2-14
025: Interrogates a Port's COR/PL Polarity . . . . .	2-15
Chapter 2 Examples . . . . .	2-16
Example 2-1: Configuring a Port as a Repeater, Link . . . . .	2-17
Example 2-2: Enable Time-Out Timers . . . . .	2-18
Example 2-3: Configuring a Ports COR/PL Polarity . . . . .	2-19
<b>Chapter 3: System Audio Control . . . . .</b>	<b>3-1</b>
003: User Control if Errors are Spoken . . . . .	3-2
007: Set Up the System's Audio Routing Variables . . . . .	3-3
008: Recall the System's Audio Routing Variables . . . . .	3-5
039: Change the Internal Audio Routing Variable . . . . .	3-6
020: Port DTMF Mute Control . . . . .	3-7
021: Check Port Mute Controls . . . . .	3-8
022: Set-up DTMF Cover Tone Variables . . . . .	3-9
Chapter 3 Examples . . . . .	3-10
Example 3-1: RLC-2 Audio Routing Variables . . . . .	3-11
Example 3-2: I want to enable DTMF muting on port 1,3 . . . . .	3-13
Example 3-3: I want to disable DTMF cover tone on muted ports . . . . .	3-13
<b>Chapter 4: System Security . . . . .</b>	<b>4-1</b>
004: Setting Up the Master System Unlock Codes . . . . .	4-2
005: Unlocking the Controller with Challenged Passwords . . . . .	4-4

	1-4
026: Unlocking the Controller with Fixed Passwords . . . . .	4-5
006: Locking the Controller . . . . .	4-6
027: Rename DTMF Command Name . . . . .	4-7
028: Command Read Back by Command Number . . . . .	4-8
029: Command Name Compare to Find Command Number . . . . .	4-9
030: Change First,Second,Third Command Name Digits . . . . .	4-10
031: Group Assign DTMF Command Mask Assign . . . . .	4-11
032: Command Checks Value of DTMF Execution Register . . . . .	4-12
033: Group Assign Master Unlock Requirement for DTMF . . . . .	4-13
034: Individually Assign Unlock Requirement for DTMF . . . . .	4-14
035: Recall DTMF Unlock Requirements on a Command . . . . .	4-15
036: Group Assign Master Unlock Requirement for Serial . . . . .	4-16
037: Individually Assign Unlock Requirement for Serial . . . . .	4-17
038: Recall Serial Unlock Requirements on a Command . . . . .	4-18
040: User Forced Execution Digit Change . . . . .	4-19
041: Check the Forced Execution Digit . . . . .	4-20
115: Assign the DTMF Decoder Priority . . . . .	4-21
Chapter 4 Examples . . . . .	4-22
Example 4-1: Accessing Locked Commands when in Challenged Password Mode . . . . .	4-23
Example 4-2: Renaming Commonly Used Commands . . . . .	4-24
Example 4-3: Renaming Commands . . . . .	4-25
Example 4-4: Assigning DTMF, Un-Lock codes, Serial masks . . . . .	4-26
Example 4-5: Changing the <Forced Execution> Digit . . . . .	4-28
<b>Chapter 5: Messages, Tones and Responses . . . . .</b>	<b>5-1</b>

	1-5
042: Generate a Tone Sequence Out Selected Ports .....	5-2
043: Generate a CW Message Out Selected Ports .....	5-4
044: Generate a DTMF Sequence Out a Selected Port .....	5-5
045: Generate a Voice Message .....	5-7
046: Delete a Message Slot .....	5-8
047: DTMF Keypad Message Generate .....	5-9
048: Recall a Message Slot 00..33 .....	5-10
049: Program a Message Slot .....	5-11
111: Set Up the CW Speed .....	5-12
112: Set Up the CW Tone Frequency .....	5-13
113: Program a 2-Tone Pager Slot .....	5-14
114: Recall the 2-Tone Paging Slot 01..20 .....	5-17
118: Program a Voice Message Delay for the Link Ports .....	5-18
Chapter 5 Examples .....	5-19
Example 5-1: Generating a Custom Courtesy Beep .....	5-20
Example 5-2: Building Port 1's ID's .....	5-21
<b>Chapter 6 System Timers .....</b>	<b>6-1</b>
050: Recall a Timer Slot .....	6-2
051: Start a Timer Slot .....	6-5
052: Program a Timer Slot .....	6-6
066: Start a User Timer .....	6-7
067: Stop a User Timer .....	6-8
023: Control DTMF Timed Execution .....	6-9

	1-6
Examples for Chapter 6 .....	6-10
Example 6-1: Using a User timer to Auto-Disconnect a Port .....	6-11
Example 6-2: How to correctly set-up your ID timers .....	6-13
<b>Chapter 7 Scheduler, Time-of Day Clock</b> .....	<b>7-1</b>
053: Speak Good Morning, Afternoon, or Evening .....	7-2
054: Recall Time-of-Day Clock (Male) .....	7-3
055: Recall Time-of-Day Clock (Female) .....	7-4
056: Recall Date (Male) .....	7-5
057: Recall the Day (Male) .....	7-6
058: Setting the Time .....	7-7
059: Setting the Date .....	7-8
060: Scheduler Event Recall .....	7-9
061: Scheduler Event Program .....	7-10
062: Scheduler Event Enable/Disable .....	7-13
Examples for Chapter 7 .....	7-14
Example 7-1: Set-up the Scheduler to reset my Analog High/Low Readings at 12:00AM .....	7-15
Example 7-2: Set-up the Scheduler to Enable Time readings on the hour beginning at 8:00 AM until 6:00 PM .....	7-16
<b>Chapter 8: Event Tables</b> .....	<b>8-1</b>
063: Recall an Event .....	8-2
064: Program an Event .....	8-3
065: Enable/Disable an Event .....	8-11
Examples for Chapter 8 .....	8-12
Example 8-1: How to have a Voice ID revert to a CW ID .....	8-13

**Chapter 9: Analog Input System** . . . . . 9-1

070: Analog Line Faceplate Assignment . . . . . 9-2

071: Recall Analog Faceplate . . . . . 9-5

072: Analog Line Calibration . . . . . 9-6

073: Recall Analog Line Calibration . . . . . 9-7

074: Reset Analog 1-4 High/Low Values . . . . . 9-8

075: Read an Analog Line . . . . . 9-9

076: Read an Analog High Value . . . . . 9-10

077: Read an Analog Low Value . . . . . 9-11

078: Read an Analog High Line Time . . . . . 9-12

079: Read an Analog Low Line Time . . . . . 9-13

080: Read an Analog High Date . . . . . 9-14

081: Read an Analog Low Date . . . . . 9-15

082: Analog Line Alarm Value Program . . . . . 9-16

083: Check Analog Alarm Points . . . . . 9-19

084: Check Analog Active Alarms . . . . . 9-20

Examples for Chapter 9 . . . . . 9-21

Analog Input Telemetry Lines . . . . . 9-22

Example 9-1: Configure a High Temperature Alarm . . . . . 9-23

Temperature Sensor Hook-Up . . . . . 9-24

Reading AC Voltage with an Analog Input Line . . . . . 9-25

Reading Wind Speed with Analog Input 4 . . . . . 9-26

**Chapter 10: Input and Output Lines** . . . . . 10-1

085: Read Input Lines . . . . . 10-2

	1-8
086: Output Line 1 On .....	10-3
087: Output Line 1 Off .....	10-3
088: Output Line 2 On .....	10-3
089: Output Line 2 Off .....	10-3
090: Output Line 3 On .....	10-3
091: Output Line 3 Off .....	10-3
092: Output Line #..# On .....	10-4
093: Output Line #..# Off .....	10-5
094: Check Output Lines .....	10-6
Examples for Chapter 10 .....	10-7
Example 10-1: Configure a Door Alarm .....	10-8
Magnetic Door Switch Drawing .....	10-9
Output Line Relay Driver Drawing .....	10-11
Logical Input Lines .....	10-12
Input line reading AC power fail Drawing .....	10-13
<b>Chapter 11: Doug Hall RBI-1, RLC-ICM and Misc.Remotes</b> .....	11-1
A Brief Description on how to use: Remote Base Functions .....	11-2
095: Enter Frequency Plus Offset for RBI-1, RLC-ICM .....	11-3
096: Set PL Frequency, Encode On-Off, Decode On-Off .....	11-4
097: Recall Memory Channels on RBI-1 .....	11-7
098: Set Power on the RBI-1 .....	11-8
099: Turn RBI-1 Radio Band Power On-Off .....	11-9
100: Reset External Interface .....	11-10



	1-9
101: Configure the RLC-ICM Module .....	11-11
102: Recall Frequency .....	11-13
103: Recall All Remote Variables .....	11-14
104: External Serial Data Send - Parallel BCD Controller .....	11-15
110: Pulse Output Line 'X' 'Y' Times .....	11-16
Chapter 11 Examples .....	11-17
Building a cable to interface the RLC-ICM/RBI-1 Interfaces .....	11-20
<b>Chapter 12: HF Remote Base Radio</b> .....	12-1
105: HF Mode Configure .....	12-2
106: HF Mode Enable .....	12-3
HF Remote Base Keypad .....	12-4
107: HF Mode Disable .....	12-6
108:Enter Icom's HF Radio Address or Kenwood's radio type .....	12-7
109: Command Line Control of the HF Routines .....	12-9
Chapter 12 Examples .....	12-10
Example 12-1: I need a macro to set-up the HF remote up .....	12-11
HF Radio Interfacing .....	12-12
<b>Chapter 13: Pre-Access Code Set-up</b> .....	13-1
120: Assign the 3 Ports Link Prefixes .....	13-2
121: Configure Pre-Access on a Port .....	13-3
122: Enable/Disable Pre-Access on a Port .....	13-4
123: Pre-Access Configure for the Stop Access Mode .....	13-5
Chapter 13 Examples .....	13-6
Example 13-1: Configuring ports for Pre-access .....	13-7

Example 13-2: Pre-Access Events, Configurations and Uses ..... 13-8

**Chapter 14: The Autopatch System** ..... 14-1

119: Reverse Autopatch Call-Sign Beaconing Request ..... 14-2

125: Reverse Autopatch Answer on the Repeater ..... 14-4

126: Configure the Reverse Autopatch ..... 14-5

127: Configure the Forward Autopatch ..... 14-7

128: Program Dialing Number Allow Table ..... 14-8

129: Recall Dialing Number Allow Table ..... 14-9

130: Enable/Disable Number Allow Table Entry ..... 14-10

132: Program Memory Dial ..... 14-11

133: Recall Memory Dial Slot ..... 14-12

134: Enable/Disable Dialing Slot ..... 14-13

135: Program Call Sign Assignment ..... 14-14

136: Recall Call Sign Assignment ..... 14-15

137: Set Up Autodial Mode ..... 14-16

138: Program a Nuisance Number Slot ..... 14-17

139: Recall a Nuisance Number Slot ..... 14-18

140: Enable/Disable a Nuisance Slot ..... 14-19

141: Programs Pre-Dial Digits and Controls Dialing ..... 14-20

142: Recalls Pre-Dial Digits ..... 14-21

143: Patch On-Line with Dialing Table Checking ..... 14-22

144: Patch On-Line without Dialing Table Checking ..... 14-23

145: Manual Patch On-Line ..... 14-24

	1-11
146: Hanging Up the Patch .....	14-25
147: Call Sign Request and Enter Programming Mode .....	14-26
148: Last Number Redial .....	14-27
149: Reset Autopatch Time-Out Timer .....	14-28
Chapter 14 Examples .....	14-29
Example 14-1: Configuring for 7 digit dialing .....	14-30
Example 14-2: Setting the controller for Callsigns on dialing .....	14-31
Example 14-3: Reverse Autopatch Programming .....	14-32
Example 14-4: Direct Dialing Flowchart .....	14-33
Example 14-5: Memory Dialing Flowchart .....	14-34
Example 14-6: Autopatch Audio Routing .....	14-35
<b>Chapter 15: Digital Voice Recorders .....</b>	<b>15-1</b>
150: Playback Small DVR Slot 01..34 .....	15-2
151: Record a Small DVR Slot 01..34 .....	15-3
152: Delete a Small DVR Slot 01..34 .....	15-4
153: Select DVR Types .....	15-5
The Large Digital Voice Recorder .....	15-6
What the DVR is .....	15-6
Memory Installation and Testing: .....	15-7
The Serial Interface .....	15-11
154: Play DVR Track .....	15-13
155: Record DVR Track .....	15-14
156: Erase DVR Tracks .....	15-15
157: Retrieve Private Mail .....	15-16
158: Record Private Mail .....	15-17

		1-12
159:	Erase Private Mail .....	15-18
160:	Record Public Mail .....	15-19
161:	Retrieve Public Mail .....	15-20
162:	Erase Public Mail .....	15-21
068:	Check Public Mailboxes .....	15-22
163:	Record and Play Audio Test .....	15-23
Chapter 15 Examples .....		15-24
Example 15-1: Setting up message slots for Voice Mail .....		15-25
<b>Chapter 16: Macros</b> .....		16-1
164:	Serial Recall a range of Macros .....	16-2
165:	Erase a Macro Position .....	16-3
166:	Enable/Disable a Macro Position .....	16-4
167:	Recall a Macro Position .....	16-5
168:	Program/Append a Macro Position .....	16-6
169:	Cancel all Responses Following This Command .....	16-7
170:	Re-enables all Responses Following This Command .....	16-7
171..240:	Execute Macro #01..#70 .....	16-8
Chapter 16 Examples .....		16-10
<b>Chapter 17: Serial Commands</b> .....		17-1
069:	Serial LED Status Screen .....	17-2
241:	Serial Upload Data File .....	17-3
242:	Serial Download Data File .....	17-4
243:	Serial Command Name List .....	17-5
244:	Change the Serial Baud Rate or Send Serial Data .....	17-6

	1-13
Chapter 17 Examples .....	17-7
Example 17-1: Setting up the Serial Port .....	17-8
Example 17-2: I want to download the RAM into a file .....	17-9
<b>Chapter 18: Misc. Commands</b> .....	<b>18-1</b>
116: Resistor #1,#2 Send Routine .....	18-2
117: Recall Software Resistor Settings .....	18-3
245: Remotely Reset the Controller .....	18-4
Chapter 18 Examples .....	18-5
Example 18-1: Applications for the software resistors .....	18-6
Squelch control with a Software Resistor .....	18-6
<b>Chapter 19: Tables, Drawings and Layouts</b> .....	<b>19-1</b>
Appendix A: ASCII Data Table .....	19-1
Appendix B: Tone Frequency Conversion Table .....	19-2
Appendix C: Voice Word Look-up Table .....	19-7
Special Voice Words .....	19-13
Appendix D: Hardware .....	19-14
Board Layout .....	19-15
Schematic Diagrams .....	19-17
Bill of Materials .....	19-31

## *Index of Command Names*

000: Connect one Port to another Port . . . . .	2-2
001: Monitor one Port from another Port . . . . .	2-3
002: Disconnect one Port from another Port . . . . .	2-4
003: User Control if Errors are Spoken . . . . .	3-2
004: Setting Up the Master System Unlock Codes . . . . .	4-2
005: Unlocking the Controller with Challenged Passwords . . . . .	4-4
006: Locking the Controller . . . . .	4-6
007: Set Up the System's Audio Routing Variables . . . . .	3-3
008: Recall the System's Audio Routing Variables . . . . .	3-5
009: Checking Cross-Point Connections . . . . .	2-5
010: Time-Out Timer Enabled/Disabled . . . . .	2-6
011: Check Time-Out Timer Status . . . . .	2-7
012: Program a Receiver's Access Mode . . . . .	2-8
013: Checking Access Modes . . . . .	2-9
014: Port Supervisory PTT Control . . . . .	2-10
015: Check Port Supervisory Control Settings . . . . .	2-11
018: Receiver Active - Inactive Control Command Execution . . . . .	2-12
019: Check Receiver Active - Inactive Command Execution . . . . .	2-13
020: Port DTMF Mute Control . . . . .	3-7
021: Check Port Mute Controls . . . . .	3-8
022: Set-up DTMF Cover Tone Variables . . . . .	3-9
023: Control DTMF Timed Execution . . . . .	6-9
024: Controls a Port's COR/PL Polarity . . . . .	2-14
025: Interrogates a Port's COR/PL Polarity . . . . .	2-15
026: Unlocking the Controller with Fixed Passwords . . . . .	4-5
027: Rename DTMF Command Name . . . . .	4-7
028: Command Read Back by Command Number . . . . .	4-8
029: Command Name Compare to Find Command Number . . . . .	4-9
030: Change First,Second,Third Command Name Digits . . . . .	4-10
031: Group Assign DTMF Command Mask Assign . . . . .	4-11
032: Command Checks Value of DTMF Execution Register . . . . .	4-12
033: Group Assign Master Unlock Requirement for DTMF . . . . .	4-13
034: Individually Assign Unlock Requirement for DTMF . . . . .	4-14
035: Recall DTMF Unlock Requirements on a Command . . . . .	4-15
036: Group Assign Master Unlock Requirement for Serial . . . . .	4-16
037: Individually Assign Unlock Requirement for Serial . . . . .	4-17
038: Recall Serial Unlock Requirements on a Command . . . . .	4-18
039: Change the Internal Audio Routing Variable . . . . .	3-6
040: User Forced Execution Digit Change . . . . .	4-19
041: Check the Forced Execution Digit . . . . .	4-20
042: Generate a Tone Sequence Out Selected Ports . . . . .	5-2
043: Generate a CW Message Out Selected Ports . . . . .	5-4
044: Generate a DTMF Sequence Out a Selected Port . . . . .	5-5
045: Generate a Voice Message . . . . .	5-7

046: Delete a Message Slot . . . . .	5-8
047: DTMF Keypad Message Generate . . . . .	5-9
048: Recall a Message Slot 00..33 . . . . .	5-10
049: Program a Message Slot . . . . .	5-11
050: Recall a Timer Slot . . . . .	6-2
051: Start a Timer Slot . . . . .	6-5
052: Program a Timer Slot . . . . .	6-6
053: Speak Good Morning, Afternoon, or Evening . . . . .	7-2
054: Recall Time-of-Day Clock (Male) . . . . .	7-3
055: Recall Time-of-Day Clock (Female) . . . . .	7-4
056: Recall Date (Male) . . . . .	7-5
057: Recall the Day (Male) . . . . .	7-6
058: Setting the Time . . . . .	7-7
059: Setting the Date . . . . .	7-8
060: Scheduler Event Recall . . . . .	7-9
061: Scheduler Event Program . . . . .	7-10
062: Scheduler Event Enable/Disable . . . . .	7-13
063: Recall an Event . . . . .	8-2
064: Program an Event . . . . .	8-3
065: Enable/Disable an Event . . . . .	8-11
066: Start a User Timer . . . . .	6-7
067: Stop a User Timer . . . . .	6-8
068: Check Public Mailboxes . . . . .	15-22
069: Serial LED Status Screen . . . . .	17-2
070: Analog Line Faceplate Assignment . . . . .	9-2
071: Recall Analog Faceplate . . . . .	9-5
072: Analog Line Calibration . . . . .	9-6
073: Recall Analog Line Calibration . . . . .	9-7
074: Reset Analog 1-4 High/Low Values . . . . .	9-8
075: Read an Analog Line . . . . .	9-9
076: Read an Analog High Value . . . . .	9-10
077: Read an Analog Low Value . . . . .	9-11
078: Read an Analog High Line Time . . . . .	9-12
079: Read an Analog Low Line Time . . . . .	9-13
080: Read an Analog High Date . . . . .	9-14
081: Read an Analog Low Date . . . . .	9-15
082: Analog Line Alarm Value Program . . . . .	9-16
083: Check Analog Alarm Points . . . . .	9-19
084: Check Analog Active Alarms . . . . .	9-20
085: Read Input Lines . . . . .	10-2
086: Output Line 1 On . . . . .	10-3
087: Output Line 1 Off . . . . .	10-3
088: Output Line 2 On . . . . .	10-3
089: Output Line 2 Off . . . . .	10-3
090: Output Line 3 On . . . . .	10-3
091: Output Line 3 Off . . . . .	10-3
092: Output Line #..# On . . . . .	10-4

093: Output Line #.# Off	10-5
094: Check Output Lines	10-6
095: Enter Frequency Plus Offset for RBI-1, RLC-ICM	11-3
096: Set PL Frequency, Encode On-Off, Decode On-Off	11-4
097: Recall Memory Channels on RBI-1	11-7
098: Set Power on the RBI-1	11-8
099: Turn RBI-1 Radio Band Power On-Off	11-9
100: Reset External Interface	11-10
101: Configure the RLC-ICM Module	11-11
102: Recall Frequency	11-13
103: Recall All Remote Variables	11-14
104: External Serial Data Send - Parallel BCD Controller	11-15
105: HF Mode Configure	12-2
106: HF Mode Enable	12-3
107: HF Mode Disable	12-6
108: Enter Icom's HF Radio Address or Kenwood's radio type	12-7
109: Command Line Control of the HF Routines	12-9
110: Pulse Output Line 'X' 'Y' Times	11-16
111: Set Up the CW Speed	5-12
112: Set Up the CW Tone Frequency	5-13
113: Program a 2-Tone Pager Slot	5-14
114: Recall the 2-Tone Paging Slot 01..20	5-17, 5-18
115: Assign the DTMF Decoder Priority	4-21
116: Resistor #1,#2 Send Routine	18-2
117: Recall Software Resistor Settings	18-3
120: Assign the 3 Ports Link Prefixes	13-2
121: Configure Pre-Access on a Port	13-3
122: Enable/Disable Pre-Access on a Port	13-4
123: Pre-Access Configure for the Stop Access Mode	13-5
125: Reverse Autopatch Answer on the Repeater	14-2, 14-4
126: Configure the Reverse Autopatch	14-5
127: Configure the Forward Autopatch	14-7
128: Program Dialing Number Allow Table	14-8
129: Recall Dialing Number Allow Table	14-9
130: Enable/Disable Number Allow Table Entry	14-10
132: Program Memory Dial	14-11
133: Recall Memory Dial Slot	14-12
134: Enable/Disable Dialing Slot	14-13
135: Program Call Sign Assignment	14-14
136: Recall Call Sign Assignment	14-15
137: Set Up Autodial Mode	14-16
138: Program a Nuisance Number Slot	14-17
139: Recall a Nuisance Number Slot	14-18
140: Enable/Disable a Nuisance Slot	14-19
141: Programs Pre-Dial Digits and Controls Dialing	14-20
142: Recalls Pre-Dial Digits	14-21
143: Patch On-Line with Dialing Table Checking	14-22



144: Patch On-Line without Dialing Table Checking . . . . .	14-23
145: Manual Patch On-Line . . . . .	14-24
146: Hanging Up the Patch . . . . .	14-25
147: Call Sign Request and Enter Programming Mode . . . . .	14-26
148: Last Number Redial . . . . .	14-27
149: Reset Autopatch Time-Out Timer . . . . .	14-28
150: Playback Small DVR Slot 01..35 . . . . .	15-2
151: Record a Small DVR Slot 01..35 . . . . .	15-3
152: Delete a Small DVR Slot 01..35 . . . . .	15-4
153: Select DVR Types . . . . .	15-5
154: Play DVR Track . . . . .	15-13
155: Record DVR Track . . . . .	15-14
156: Erase DVR Tracks . . . . .	15-15
157: Retrieve Private Mail . . . . .	15-16
158: Record Private Mail . . . . .	15-17
159: Erase Private Mail . . . . .	15-18
160: Record Public Mail . . . . .	15-19
161: Retrieve Public Mail . . . . .	15-20
162: Erase Public Mail . . . . .	15-21
163: Record and Play Audio Test . . . . .	15-23
164: Serial Recall a range of Macros . . . . .	16-2
165: Erase a Macro Position . . . . .	16-3
166: Enable/Disable a Macro Position . . . . .	16-4
167: Recall a Macro Position . . . . .	16-5
168: Program/Append a Macro Position . . . . .	16-6
169: Cancel all Responses Following This Command . . . . .	16-7
170: Re-enables all Responses Following This Command . . . . .	16-7
171..240: Execute Macro #01..#70 . . . . .	16-8
241: Serial Upload Data File . . . . .	17-3
242: Serial Download Data File . . . . .	17-4
243: Serial Command Name List . . . . .	17-5
244: Change the Serial Baud Rate or Send Serial Data . . . . .	17-6
245: Remotely Reset the Controller . . . . .	18-4



**Link Communications, Inc.**  
**Repeater, Linking and Monitor Control Systems**

**Return Policy**

These policies supersede policies appearing on all other Link Communications, Inc. literature and are in effect for purchases made after March 1, 1989.

- **Please keep all packing material and documentation in the event that your equipment has to be serviced or returned.**
- Before returning any product, you must obtain a Return Authorization (RMA) number. You can obtain this by calling (406) 482-7515.
- **No returns, of any type, will be accepted without an RMA number. Please have the following information on hand when calling for an RMA number:** customer name, invoice number, serial number, and the nature of the problem. All can be found on your invoice.
- All product to be returned must **be returned within 30 days** from the invoice date, 100% complete, and must include manuals, parts bags, and other accessories provided by the manufacturer.
- All defective products will be accepted directly by Link Communications, Inc. for credit, exchange, replacement, or repair at Link Communications, Inc.'s discretion. **After 30 days from invoice date, the manufacturer's warranty applies.**
- All non-defective returns for credit, exchange, or refund are subject to a restocking fee on the schedule listed below. No returns will be accepted beyond the 30 day period. Shipping costs are not refundable.
  - 0 to 10 days            5% restocking
  - 11 to 20 days        10% restocking
  - 21 to 30 days        15% restocking
- **Link Communications, Inc. reserves the right to authorize product returns beyond 30 days from date of invoice. If the product is accepted after 30 days, credit will be issued toward FUTURE PURCHASE ONLY.**

If you have any questions — JUST ASK.

All of us have tried to make sure that this order has been shipped correctly. If we have made an error - we want to make it right. If you have a question or problem with this order, just write or call, and our staff will personally handle your situation.

Link Communications, Inc. is a Montana Corporation

FEIN 81-0490597

## *Chapter 1: Getting Started*

This chapter deals with the information needed in getting the controller rolling and on the air. Read the sections carefully and familiarize yourself with the operations of the controller. Read through the sections on setting up events to allow ID's and enable messages.

### *Technical Support:*

Link Communications, Inc. provides technical support to all users of Links products. We can try to answer your questions to our best ability. There may be some questions that we can not answer while on the telephone. We will do our best to locate a satisfactory response to your question. We can not, however, answer every question. Questions on equipment other than Link Communications, Inc. equipment will be handled on an individual basis. To help us in answering your questions do some preparations before calling us.

- Have the model number of your controller (RLC-1,2,3,4,5,Club)
- Have your controllers serial number. This is very important
- Have the software version before you call. This is available using Command 048, slot 00
- Read your manual
- Write down your questions before hand and have the programming **that you have tried** with each question
- Have any errors you received noted
- Before you call check the errors you received with the errors in the manual and verify the data you entered to try to determine how you received that error
- **Technical support is only handled at the following number (406) 482-7515**
- No technical support will be provided on the '800 sales number.

Remember that we receive hundreds of technical support calls every week. Please keep your calls short and to the point so we can provide all Link Communications, Inc. easy technical support.

You can also fax us your questions at: +(406) 482-7547

Email access: support@link-comm.com

World wide web access to latest software releases and manuals:

<http://www.link-comm.com>

## ***Introduction:***

Congratulations, you have purchased a very powerful tool for your group's repeater. The RLC-2 may seem complicated and intimidating at first, but don't worry. Setting it up and programming it are easy and straightforward, once you have read the manual. Please take the time to read it before you try to start programming. This will save you a lot of confusion and frustration, as it should answer most of your questions.

The RLC-2 repeater controller consists of one repeater port, two linking ports, four analog voltage inputs, four logical (dry contact) inputs, and eight MOSFET output drivers. The repeater port and each of the linking ports can be configured to require one of several combinations of COR and PL inputs for access. The RLC-2 has a single DTMF decoder that scans between the three receiver ports, thereby supporting DTMF control from all ports of the controller. Synthesized voice prompts the users in the programming of the controller's variables, provides voice ID's and alarms based on the inputs, etc.

This manual consists of three main sections: setup and interfacing, programming and commands, and the appendices with commonly referenced tables and charts. A glossary has also been included at the end to explain some of the terms and abbreviations that are used throughout the manual.

We have attempted to explain everything in a way that is easy to understand, but some questions are inevitable. If you have carefully read the manual and still have questions, call or us at (406) 482-7515 or Fax us at (406) 482-7547 or Email us at [support@link-comm.com](mailto:support@link-comm.com)

Link Communications Inc.  
P.O. Box 1071  
Sidney, MT 59270

## **Limited Warranty**

### **Coverage:**

Link Communications warrants that its products will be free from defects in materials and workmanship for a period of one year from the date of shipment. During this time, Link Communications will cover parts, labor and return shipping. If failure is caused by instances other than manufacturing defects, Link Communications will repair the product and bill the customer for parts and labor. Contact Link Communications for more information.

### **What Link Communications will not cover:**

1. Too much voltage to the controller. The RLC-2 operates at +11V to +15V, negative ground.
2. Damage to the controller by lightning, accident, or incorrect power hook-up.
3. Incorrect unit installation.
4. Damage caused by shipment (damage claims are handled by the carrier).
6. Repairs by other than Link Communications Inc.

### **THIS WARRANTY HOLDS ONLY TO THE ORIGINAL PURCHASER**

### **How to get service**

Please contact Link Communications for servicing information and authorization.

### **Software**

Link Communications holds the copyright on the RLC-2's software and hardware. Changes to the software, copying of the software, and use of the voice code is prohibited without the written consent of Link Communications.

### **Software updates**

Link Communications will provide FREE Software updates for 6 months from the date of purchase. The owner must return replaced software chips to Link Communications in order to obtain further software updates. Software updates will cost \$25.00 after the update warranty expires. Manual inserts and shipping are additional.

**User Survey (Optional)**

A knowledge of the user base will allow us to better serve you in the future by helping us develop more specialized software and hardware. Please take a few minutes and fill out this questionnaire.

**RLC-2 Serial Number** ..... \_\_\_\_\_

**RLC-2 Purchase Date** ..... \_\_\_\_\_

**Application:** (Circle All That Apply)

**Ownership:**

- 1 - Privately Owned Repeater
- 2 - Club Owned Repeater
- 3 - Group Owned Repeater
- 4 - Commercial Business Repeater
- 5 - Other \_\_\_\_\_

**Installation:**

- 1 - Wide Coverage Repeater with Chain Links
  - Port to Port Linking
- 2 - Full Duplex Links
- 3 - Half Duplex Links
- 4 - VHF Repeater: Power \_\_\_\_\_ Make \_\_\_\_\_
- 5 - UHF Repeater: Power \_\_\_\_\_ Make \_\_\_\_\_
- 6 - Link Ports Used as Repeater Ports: Yes No
- 7 - Serial Data Used to Control Repeater: Yes No
- 8 - Other Amateur Repeaters At the Site: Yes No
- 9 - Other Link Communication Products Used: Yes No

**Misc:**

- 1 - User Base: Technical Rag Chew Personal
- 2 - Autopatch used on the System: Yes No
- 3 - Frequency Adjustable Remotes: Yes No
- 4 - Linking to Other Repeaters: Yes No
- 5 - Linking Closed Access: Yes No
- 6 - PL Required on Main Repeater: Yes No Varies
- 7 - PL Required on Linking System: Yes No Varies

**Please Return to: Link Communications Inc.**

**P.O. Box 1071  
Sidney, MT 59270-1071**

Comments:

## ***Re-Initialization the Controller***

When the RLC-2 powers up, a warm reset is processed. This reset will load the most recent variables into the controller. The variables are stored in the nonvolatile RAM chip located on the controller board. If the variables in the SRAM get scrambled somehow, a cold boot will be needed. This cold boot resets all of the RLC-2's variables to the preprogrammed values. This cold boot is accomplished by pressing and holding the initialize switch and pushing the reset switch. Another easier method of re-initializing the controller is to hold the initialization switch down and applying power to the controller. You must hold the initialize switch down for at least 5 seconds after you either reset the controller or apply power to the controller. Once the controller has been initialized, the reset switch must be pushed again.

You know if the controller has been re-initialized if the voice speaks the message:

**"This Is The RLC-2 Repeater And Link Controller V 4.XX"**

\*\*\* Caution, Initialization will clear all user programmed variables \*\*\*

1. Depress the "Initialize (INIT)" switch and hold
2. Depress and Release the Reset Switch while continuing to hold the Initialize switch or while the Initialize (INIT) switch is depressed apply power to the controller.
3. After 5 seconds let go of the "Initialize" switch
4. Depress and Release the Reset switch to Initialize the RLC-2

## ***Resetting the Controller***

Resetting the controller is as easy as pressing the Reset switch on the controllers board. The same function is possible by powering off the controller and powering it back on. Software access to a remote reset is possible by executing Command 245. All of these processes will soft boot the controller. When the controller has a soft boot, variables from the internal Non-Volatile SRAM chip will be loaded and used for the controllers operation. A reset will not effect the settings of these variables. Only a re-initialization will change the settings of the internal user programmed variables.

## ***Troubleshooting the Controller***

### **No LED's when the RLC-2 is powered up**

Check for +12 Volts at Power Connector

Check for bad or blown fuse

Make sure that the +12 Volts is connected correctly

- Center of Plug is (+), Shield is (-)

### **Only Some of the LED's are lit**

Cross-Point Board is not plugged in correctly (RLC-2 Rev. A,B)

Short on that specific power supply

- Call Link Communications Inc. if this occurs

### **No Audio at Test Bus**

Check for main system power (All LED's lit)

Is there a valid COR signal present on the receiver: (Default: Active Low)

### **Have audio at the test bus, but not on the transmitter**

Are the output audio pots adjusted correctly

Is the transmitter connected to the controllers audio output: Pin 4 on the DB-09

Is the PTT connected to the controller: Pin 3 (Low on Transmit)

### **The Voice Synthesizer seems muffled**

Turn down the pot marked 'Voice'

### **When I connect my COR, the RLC-2 will not accept it**

My COR is set for active Low, does the COR go to ground when active

My COR is set for active High, does the COR go to ground when inactive

Can the COR sink (2mA) when active

Does the 5V pull-up resistor conflict with your radio

-- Motorola R-100 Repeaters are susceptible to this

-- Open collector the driver on R-100 repeaters

### **When I connect my serial terminal, I do not get any data**

Is your terminals baud rate set to 9600,N,8,1

Are you wired to the correct connector: Serial/Resistor

Are all the RS-232 TX and RX and ground wires connected

The controller requires all RS-232 signals (TX/RX/Ground) to be connected



### \*\*\* Getting On The Air Quickly \*\*\*

Follow the steps below to get your RLC-2 operational and on the air quickly.

- 1) Read the entire manual or go to step 2
- 2) Read the 'Setup and Interfacing' section to make sure you have all of the needed parts
  - This section describes how to adjust your controller
- 3) Wire up your power cord to +12 Volts DC. Center pin is positive, shield is ground.
- 4) Wire up your radio or audio amp.
  - pin 5 is your audio input (from your receiver audio out)
  - pin 4 is your audio output (to your mike jack or amp audio input)
  - pin 7 is your COR line (active low COR required (Goes to ground when active))
  - pin 3 is your PTT input (active low on PTT (Goes to ground when active))
  - pin 2 is your PL detect input (active low on detect (Goes to ground when active))
- 5) Once you have your radio connected adjust your audio (See step 2)
- 6) Programming your controller
  - Command 048 recalls your Voice/CW messages
  - Command 049 programs your Voice/CW messages
  - Command 064 assigns what slot to use for the ID's, courtesy beeps etc...
- 7) If using an RS-232 port refer to 'Serial Port Interfacing' to get your RS-232 cable built
  - The RLC-2's serial port is not a standard DB-9 serial wiring
  - You must have both RX and TX wired for the serial port to work
  - You must have your grounds connected between the computer and RLC-2 ports
- 8) Once your serial is connected, press the reset button to see the RLC-2 copyright message
  - If you don't see the reset message check the following conditions
    - Is your Baud rate 9600 N 8 1
    - Do you have your RX and TX leads swapped (Very Common)
    - Are your grounds tied together
    - Is your computer on the correct serial port
- 9) Now you can DTMF or RS-232 control the RLC-2
- 10) The serial port does not use command names, only command numbers that range from 000..245.
- 11) Call Link Communications Inc. for more help after
  - You have read the entire manual
  - Specific questions about the controller operation

## Setup and Interfacing

This section of the manual contains everything you should need to know to get your repeater controller up and running. The numbered steps cover the basics, through connecting your radios and adjusting the RLC-2. After that there is information concerning the other input and output features of the RLC-2: the serial interface, the logical output and input lines, and the analog input lines.

### Step #1: Check the Packing List

Your package should contain the following items:

- (1) RLC-2 Repeater Controller
- (1) 2.50mm Power Connector
- (1) DB-9 Female Solder Connector
- (5) DB-9 Male Solder Connectors
- (1) RLC-2 Manual

If any of these parts are missing, contact Link Communications Inc.

### Step #2: Connect Power

- The RLC-2 is designed to run off of 12V DC. 11V to 14V should work fine.
- Locate the 2.50mm power connector included in your parts bag.
- Unscrew the plastic outer shield and thread your power and ground wires through it (20 gauge suggested).
- Solder the +12V wire to the center pin of the 2.50mm connector.
- Solder the ground wire to the shield of the 2.50mm power connector.
- Screw on the plastic outer shield.
- When power is applied to the RLC-2 controller, the 5 LED's on the RLC-2 controller should light, indicating proper board operation. **If all of the LED's do not light, turn off the power immediately.**

### Step #3: Connecting Your Receivers to the RLC-2

The main repeater and each of the links connect to the RLC-2 using a male DB-9 connector (included). The control receiver connects to the same DB-9 as the main repeater. The pin-outs are listed below.

## Port 1 (Repeater Port)

Pin #	Signal Name	Default Condition
1	Control RX COR	Active Low
2	PL Decoder Input	Active Low
3	Transmitter PTT	Always Active Low
4	Transmitter Audio	Audio Output, 600Ω
5	Receiver Audio	Audio Input, 10KΩ
6	Control Receiver Audio	Audio Input, 10KΩ
7	Receiver COR Input	Active Low
8	Ground Available	....
9	Ground Available	....

## Ports 2 and 3 (Link or Repeater Ports)

Pin #	Signal Name	Default Condition
1	Ground Available	....
2	PL Decoder Input	Active Low
3	Transmitter PTT	Always Active Low
4	Transmitter Audio	Audio Output, 600Ω
5	Receiver Audio	Audio Input, 10KΩ
6	Ground Available	....
7	Receiver COR Input	Active Low
8	Ground Available	....
9	Ground Available	....

**Connecting the Receiver COR**

- The first step in connecting your receiver is to locate the receivers COR signal. The RLC-2 will accept either active low or active high COR signals. The default COR is set to **Low**. The signal must be able to sink 4mA to ground. The input impedance of the RLC-2 COR input is 10KΩ and it is diode clamped with internal pull-up resistors. This allows it to handle input voltages of up to 15 volts without damage to the controller. **The COR input must not go below 0V (ground); this would damage the 82C55 IC.** Using one of the supplied DB-9 Male connectors, connect your COR signal to pin #7 (or pin #1 for the control receiver). Refer to Commands 024 and 025 to change your ports COR and PL polarity.

### Connecting a PL Input (optional)

- If you wish to use a PL (CTCSS) decoder on any of the receivers, it can be connected to pin #2 of the appropriate connector in the same fashion as the COR input. This signal can be either an active low or active high signal. Refer to Commands 024 and 025 to change your ports COR and PL polarity.

### Connecting the Receiver Audio

- 2 types of audio can be used on the RLC-2 controller:

Type 1: De-emphasized audio (Speaker Audio)

Type 2: Discriminator audio (Raw Unsquelched Audio)

- If type 1 audio is used, remove the appropriate jumper on the controller. This removes the de-emphasis filter from the circuit. As the controller comes shipped, all ports are set up for type 2 audio.

### Receiver De-emphasis Jumpers

J1 - Port 1 Receiver De-emphasis Jumper

J2 - Port 2 Receiver De-emphasis Jumper

J3 - Port 3 Receiver De-emphasis Jumper

J4 - Control Receiver De-emphasis Jumper (J8 on Rev. A,B Boards)

- If type 2 audio is used, place the appropriate jumper in circuit (over both pins). This will place a -6dB/octave de-emphasis filter into the circuit. Some discriminators can not directly drive the 10K $\Omega$  input impedance. If this is the case, a pre-driver or different audio access point will be required. The filter will not allow PL to pass through the controller. Contact Link Communications Inc. if your needs require PL to pass through the controller.

- The audio input is connected to pin #5 of the male DB-9 connector (pin #6 for the control receiver).

- The audio adjustments will be described in Step #4.

### How the DTMF Decoder Works

- The RLC-2's DTMF decoding circuit uses a scanner that enables the controller to receive tones from all the ports, without mixing the three receiver's audio together. This allows the receivers to have total control of the DTMF decoder when its COR is active. If the control receiver is active, and the control receiver is configured for priority control, then the DTMF decoder is locked to the control receiver's port until its COR goes away. Once the decoder has detected a tone on one of the ports, it stops scanning and waits up to three seconds for the next digit. It is reset at the beginning of each DTMF digit. If any of the DTMF digits are held for longer than 5 seconds or there is a pause of 5 seconds between digits, the DTMF scanner will resume scanning and all digits entered up to that point are lost.

## **Step #4: Connecting Your Transmitters to the RLC-2**

### **Transmitter PTT**

- The RLC-2 produces an active low PTT signal (ground when PTT is active). This output is buffered with an open collector type driver capable of sinking 150mA. There is a built in 30V zener clamping diode to protect the PTT MOSFET from the high voltage spikes that can be caused by interfacing to a PTT relay coil. Your transmitter PTT input should be connected to pin #3 of the DB-9 connector.

### **Transmitter Audio**

- The RLC-2 provides a 10K $\Omega$  output impedance to your transmitter audio input.  
 - The transmitter audio is connected to pin #4 of the DB-9 connector.  
 - If it is not already, the DB-9 plug can now be plugged into the appropriate jack on the main board. The main repeater goes to the jack nearest the power jack, Port 2 is right next to it, and Port 3 is the third from the left (with the DB-9s toward you).

## **Step #5: Adjusting the RLC-2 Controller**

- Locate connector JP1 on the RLC-2 (It is the 10 pin female connector). This test bus will provide the signals that we need to adjust the inputs on the RLC-2. In order to maintain audio deviation during channel switching, all of the receiver inputs to the Cross-Point Board must be set to the same level. These signals can be measured with an oscilloscope or a true RMS AC voltmeter. In order to obtain an audio signal on JP1, a valid COR or PL must be received. Once a valid access signal is received, the RLC-2 will un-squelch the audio and be present on JP1.

### **Repeater (Port 1) Receiver Adjustment:**

- Execute Command 000 12 and 000 13 to enable Port 1-Port 2, and Port 1 - Port 3

#### **Port 1 Receiver: Transmitter Port Adjustment:**

- Present a stable Tone or DTMF tone to Port 1 RX.  
 - Adjust the 'Main RX' pot so that the signal on pin 1 of JP1 is 1 volt peak-to-peak.  
 - Adjust the 'Main TX' pot to obtain the desired deviation.

#### **Port 2 Transmitter Port Adjustment:**

- Adjust the 'Link 1 TX' pot to obtain the same deviation as the Main TX is.

#### **Port 3 Transmitter Port Adjustment:**

- Adjust the 'Link 2 TX' pot to obtain the same deviation as the Main TX is.

#### **Port 2 Receiver Port Adjustment:**

- Present the same Tone or DTMF signal used in Port 1 receiver: transmitter port adjustment step. While watching the Port 1 TX audio, adjust 'Link 1 RX' pot for the same deviation that was present on the Port 1's TX.

**Port 3 Receiver Port Adjustment:**

- Present the same Tone or DTMF signal used in Port 1 receiver: transmitter port adjustment step. While watching the Port 1 TX audio, adjust 'Link 2 RX' pot for the same deviation that was present on the Port 1's TX.

**Voice Level Adjustment:**

- Use Keypad Test (047) to generate Voice Data.  
- Adjust 'Voice' pot to 2.0 KHZ deviation or until it "sounds" good, this adjustment is for all transmitters.

**Tone Generators Adjustment:**

- Adjust 'Tone 1' to 1.5 KHZ deviation, Adjust 'Tone 2' to 1.5 KHZ deviation  
- This adjustment is for all transmitters.

**Control Receiver Adjustment**

- Present a stable Tone or DTMF Tone to Control RX.  
-- Use Command 000 15 to route the control receiver audio to Port 1's TX port  
- Adjust 'CON RX' pot to match the deviation used earlier

## Serial Port Interfacing

The RLC-2 has a serial terminal port for interfacing to any serial device, i.e. packet and serial terminal. This allows the user to monitor, control, and program all facets of the controller. The serial terminal carries highest priority for access and programming of the RLC-2.

### RS-232 Signals and Interfacing

The RLC-2 output is the RS-232 standard,  $\pm 12V$ . The serial terminal port also contains the I/O pins for the software controlled resistors. (See the Software Resistor Section for interfacing programming information).

#### Pin-Out Serial P6 Connector

Pin Number	DB-09 Computer	DB-25 Computer	Signal Definition
4	3	2	RS-232 Input
5	5	7	Ground
9	2	3	RS-232 Output

#### Pin-Out Software Resistors P6 Connector

Pin Number	Definition
1	Wiper Resistor #2
2	Low Side Resistor #2
3	Wiper Resistor #1
6	High Side Resistor #2
7	Low Side Resistor #1
8	High Side Resistor #1

### Local Terminal Interfacing

When using a local ASCII terminal at the RLC-2's location, an ASCII terminal can be used to communicate with the programming features of the RLC-2. The terminal's communication parameters must be set to:

Baud (Default).... 9600, Start Bits.... 1, Stop Bits ....1, Parity .... N, Word Length .... 8

These parameters will allow communication with the RLC-2. For system operations, see the next section "Operation and Programming Over the Serial Port".

### Configuration of the Serial Port

- Command 244 is provided to configure the serial port baud rate.
- Baud rate: Allows baud rate changes from 300,600,1200,2400,4800, and 9600 baud.

### Operation and Programming Over the Serial Port

- The RLC-2's serial port gives the controller the ability to communicate with the world over a digital radio link.

#### Serial Command Structures:

- Upper or Lower case digits may be used for the DTMF digits 'ABCD'
- All commands entered must be the commands 3 digit number that ranges from 000..245
- Spaces, Tabs, and backspaces can be used over the serial port
- Comments must begin with the ';' colon digit first. Any data following the ';' will be ignored.  
Example: 000 11 ; This command convert port 1 into a repeater port

The example shows the command number as '000' with additional data of '11' and a comment that begins with the ';' digit.

- The command sequence can be entered with either the <ENTER> key or the forced execution digit. This digit defaults to the 'D' key.

#### Serial Response:

- Voice words are printed in 2 styles
  - When the word is a number between 0..9 and/or the word is a letter of the alphabet  
The word is printed [X] where 'X' is the information
  - When the word is other than the above listed conditions  
The word is printed (###) where '###' is the word number



## *System Wide Errors*

The controller has several error messages that can be spoken if an error occurs during programming. These errors indicate that the format of the command requested does not match the data that you entered. If you get errors other than the errors listed in this section, refer to the command that you were trying to execute for more specifics.

**Error 1..5** - These errors are not system wide errors. Refer to the command you are executing if you get one of these errors.

**Error 6** - The command you requested is not allowed to be executed from this radio port. The command is DTMF masked off. Either change the DTMF mask (See Command 030,031) or try another radio port.

**Error 7** - The command you requested is locked. You must unlock the controller using Command 005 or Command 026 before this command will be executed.

**Error 8** - The command that you requested is above the requested command names. You should never get this command. If this command is spoken execute Command 244 and serially view the command names for any problems or contact Link Communications Inc.

**Error 9** - The command you are trying requires more or less additional data before it can be executed. Verify the format of the command and the amount of additional data that the command requires before trying to execute it again. If the command requires 5 digits of additional data then 5 digits must be entered

Example: Command 127 sets up the out going autopatch. This command requires 5 fields of data be entered for the command to execute correctly. If you enter less than 5 variables, then controller will speak 'Error 9'. Check your data and then check the command and enter everything required.

## ***Chapter 2: Port Connection Commands***

This section describes the commands used to connect the various ports of the controller together. A port indicates where audio goes in\out of the controller.

## ***000: Connect one Port to another Port***

This command allows you to connect one radio port to another radio port. It is also used to put a port into "repeater mode", by connecting that port to itself. "Connecting a port" means that the audio in and keying source from each port become the audio out and PTT source for the other port. Connecting a port to itself makes the audio that comes in your repeater's receiver go out your repeater's transmitter, making it into a repeater. If you connect two different ports together, they will hear the activity from the other port.

```
<000> x y
```

### **Parameters:**

- X is the first port to connect
  - Y is the second port to connect
- Ports range from 1..5
- 1 - Port 1
  - 2 - Port 2
  - 3 - Port 3
  - 4 - Autopatch Port
  - 5 - Control Receiver Port

### **Defaults:**

- Port 2,3 default as links, Port 1 defaults as a repeater

### **Error Codes:**

E1 - Invalid port requested

(System wide errors are listed in front of the manual)

### **Example 1:**

Connect Port 1 to Port 3

```
000 13 D or unkey
```

Voice response "1 3 Connect On"

Want port 1 as a repeater port

```
000 11 D or unkey
```

### **Response:**

"X Y Connect On"

## ***001: Monitor one Port from another Port***

This command allows you to monitor one radio port from another radio port.

```
<001> x y
```

### **Parameters:**

- X is the port doing the monitoring of port Y
- Y is the port being monitored

Ports range from 1..5

- 1 - Port 1
- 2 - Port 2
- 3 - Port 3
- 4 - Autopatch Port
- 5 - Control Receiver Port

### **Defaults:**

- Port 2,3 default as links, Port 1 defaults as a repeater

### **Error Codes:**

E1 - Invalid port requested

(System wide errors are listed in front of the manual)

### **Example 1:**

Monitor Port 3 by Port 1

```
001 13 D or unkey
```

### **Response:**

"X Y Connect Monitor"

## ***002: Disconnect one Port from another Port***

This command allows you to disconnect one radio port from another radio port.

```
<002> x y
```

### **Parameters:**

- X is the first port to disconnect
  - Y is the second port to disconnect
- Ports range from 1..5
- 1 - Port 1
  - 2 - Port 2
  - 3 - Port 3
  - 4 - Autopatch Port
  - 5 - Control Receiver Port

### **Defaults:**

- Port 2,3 default as links, Port 1 defaults as a repeater

### **Error Codes:**

E1 - Invalid port requested

(System wide errors are listed in front of the manual)

### **Example 1:**

Disconnect Port 1 from Port 3

```
002 13 D or unkey
```

Voice response "1 3 Connect Off"

Port 1 is currently a repeater port and you want the port configured as a link port.

```
002 11 D or unkey
```

### **Response:**

"X Y Connect Off"

## 009: Checking Cross-Point Connections

This command allows you check the audio crosspoint conditions on all radio ports on the controller. This command will check the connected conditions and both show the crosspoint map on the RS-232 serial port if executed from the RS-232 port, and will speak the conditions out the port that DTMF requested the conditions.

<009>

### Parameters:

There are no parameters for this command

### Defaults:

There are no defaults for this command

### Error Codes:

(System wide errors are listed in front of the manual)

### Response:

Voice Format:

1 Connect <TX1> <TX2> <TX3> <TX4> <TX5>  
 2 Connect <TX1> <TX2> <TX3> <TX4> <TX5>  
 3 Connect <TX1> <TX2> <TX3> <TX4> <TX5>  
 4 Connect <TX1> <TX2> <TX3> <TX4> <TX5>  
 5 Connect <TX1> <TX2> <TX3> <TX4> <TX5>

Serial Format:

		TX				
		1	2	3	4	5
	1	.	.	.	.	.
	2	.	.	.	.	.
RX	3	.	.	.	.	.
	4	.	.	.	.	.
	5	.	.	.	.	.

An 'x' indicates connection and a '.' indicates no connection.

## ***010: Time-Out Timer Enabled/Disabled***

This command allows the user to enable/disable the time-out timer port a selected port.

```
<010> x y
```

### **Parameters:**

X is the port. This number ranges from 1..5

Y is the control information.

- 1 - Enable Time-out timer
- 0 - Disable Time-out timer

### **Defaults:**

Port 1 time-out timer is enabled

Ports 2,3,4,5 time-out timers are disabled

### **Notes:**

- The FCC requires a 3 minute time-out timer on all repeater channels

### **Error Codes:**

E1 - Invalid port. Port must range from 1..5

(System wide errors are listed in front of the manual)

### **Example 1:**

I want to enable the time-out timer on Port 2's repeater

```
010 2 1 D or unkey
```

### **Response:**

"Port <ON/OFF>"

## ***011: Check Time-Out Timer Status***

This command checks the status of the time-out timers.

```
<011> x
```

### **Parameters:**

X is the port. This number ranges from 1..5

### **Defaults:**

Port 1 time-out timer is enabled

Ports 2,3,4,5 time-out timers are disabled

### **Notes:**

- The FCC requires a 3 minute time-out timer on all repeater channels

### **Error Codes:**

E1 - Invalid port. Port must range from 1..5

(System wide errors are listed in front of the manual)

### **Example 1:**

I want to make sure the time-out timer is enable for port 3.

```
011 3 D or unkey
```

### **Response:**

"Port <ON/OFF>"



## 012: Program a Receiver's Access Mode

This command allows the user to set the receiver's access mode.

```
<012> x y
```

### Parameters:

X is the receiver that the access mode is being changed. This number ranges from 1..5

Y is the access mode

Access Modes Number	Access Mode Description
0	No Access from the receiver
1	COR Access
2	PL Access
3	COR and PL Access
4	COR or PL Access

### Defaults:

All ports default to COR (1) access

### Error Codes:

E1 - Invalid port. Port must range from 1..5

E2 - Invalid access mode. Modes are listed above.

(System wide errors are listed in front of the manual)

### Example 1:

I want port 1 to require both COR and PL for access.

```
012 1 3 D or unkey
```

### Response:

"Port is <Access Mode>"

## 013: Checking Access Modes

This command checks the settings of the ports access modes.

```
<013> x
```

### Parameters:

X is the port number

### Response:

Access Modes Number	Access Mode Description
0	No Access from the receiver
1	COR Access
2	PL Access
3	COR and PL Access
4	COR or PL Access

### Defaults:

All ports default to COR (1) access

### Error Codes:

E1 - Invalid port. Port must range from 1..5

(System wide errors are listed in front of the manual)

### Example 1:

I am getting noise on my port 3. I need to see if it is still in COR and PL mode.

```
013 3 D or unkey
```

### Response:

"Port is <Access Mode>"

## ***014: Port Supervisory PTT Control***

This command allows the user to command off the system PTT for a selective port. Only the transmitter PTT is controlled. To control receiver access see Command 12

```
<014> x y
```

### **Parameters:**

X is the port. This number ranges from 1..5

Y is the control information.

- 1 - Enable Supervisory PTT control (Kills Transmitter)
- 0 - Disable Supervisory PTT control (Enables Transmitter)

### **Defaults:**

All ports transmitter enabled

### **Error Codes:**

E1 - Invalid port. Port must range from 1..5

E2 - Invalid access mode. Modes are listed above.

(System wide errors are listed in front of the manual)

### **Example 1:**

I need to shut off port 1's transmitter PTT because of some noise

```
014 1 1 D or unkey
```

### **Response:**

"Port is <ON/OFF>"

## ***015: Check Port Supervisory Control Settings***

This command checks the settings of Command 014

<015> x

### **Parameters:**

X is the port. This number ranges from 1..5

### **Defaults:**

All ports are enabled to transmit

### **Error Codes:**

E1 - Invalid port. Port must range from 1..5

(System wide errors are listed in front of the manual)

### **Example 1:**

My port 2 transmitter will not activate. I need to see if it is enabled

015 2 D or unkey

### **Response:**

"Port is <ON/OFF>"

## ***018: Receiver Active - Inactive Control Command Execution***

This command allows the user to enable/disable the execution of commands when the receiver goes from inactive. If this command is disabled for a port, the user must force the execution of the command in order for it to be accepted. When this command is enabled on a port, simply the receiver drop can execute a command

```
<018> x y
```

### **Parameters:**

X is the port. This number ranges from 1..5

Y is the control information.

- 1 - Enables Receiver drop to execute a command
- 0 - Disables Receiver drop to execute a command

### **Defaults:**

All ports allow receiver drop to execute a command sequence

### **Error Codes:**

E1 - Invalid port. Port must range from 1..5

E2 - Invalid access mode. Modes are listed above.

(System wide errors are listed in front of the manual)

### **Example 1:**

I need to keep users on the repeater from executing commands when they DTMF page other users.

```
018 1 0 D or unkey
```

### **Response:**

"Port is<ON/OFF>"

## ***019: Check Receiver Active - Inactive Command Execution***

This command checks the settings of Command 018.

```
<019> x
```

### **Parameters:**

X is the port. This number ranges from 1..5

### **Defaults:**

All ports allow receiver drop to execute a command sequence

### **Error Codes:**

E1 - Invalid port. Port must range from 1..5

(System wide errors are listed in front of the manual)

### **Example 1:**

I want to make sure port 1 does not execute commands with a receiver drop

```
019 1 D or unkey
```

### **Response:**

"Port is <ON/OFF>"

## *024: Controls a Port's COR/PL Polarity*

This command allows the user to customize the COR and PL levels. Every radio differs in how the COR and PL levels are present when the receiver is active. This command allows either active high or active low COR and PL signals to be accepted. If your receiver is active high and you need to change the COR/PL polarity and you do not have a serial terminal to change it for you, then you need to fake the COR input by tying the COR input to ground while entering Command 024. Make sure you have disconnected the ports COR input before forcing the COR to ground.

```
<024> x y
```

**Parameters:**

X is the port. This number ranges from 1..5  
 Y is the COR and PL mode

COR and PL Mode	COR and PL Levels
0	Both COR and PL active Low
1	COR Active Low, PL active High
2	COR Active High, PL active Low
3	COR and PL active High

**Defaults:**

Both COR and PL are active Low

**Notes:**

- When a receiver is not connected to the controller, the COR and PL levels on that port must be set to active low (Mode 0)

**Error Codes:**

E1 - Invalid port selected  
 (System wide errors are listed in front of the manual)

**Example 1:**

I want to connect a GE Master II receiver to my repeater port. This receiver has an active high COR output.

```
024 1 1 D or unkey
```

**Response:**

"Port is <Mode>"

## ***025: Interrogates a Port's COR/PL Polarity***

This command checks the setting of Command 025

```
<025> x
```

**Parameters:**

X is the port. This number ranges from 1..5

COR and PL Mode	COR and PL Levels
0	Both COR and PL active Low
1	COR Active High, PL active Low
2	COR Active Low, PL active High
3	COR and PL active High

**Defaults:**

Both COR and PL are active Low

**Notes:**

- When a receiver is not connected to the controller, the COR and PL levels on that port must be set to active low (Mode 0)

**Error Codes:**

E1 - Invalid port selected

(System wide errors are listed in front of the manual)

**Example 1:**

I want to check port 3's COR and PL polarity before I connect a new receiver.

```
025 3 D or unkey
```

**Response:**

"Port is <Mode>"



## *Chapter 2 Examples*

## ***Example 2-1: Configuring a Port as a Repeater, Link***

Repeaters and links indicate how a port is configured.

### **Repeater**

A repeater is defined as a port that loops the ports receive audio out the ports transmitter. When the receiver becomes active, the transmitter of the same port should go active. When the receiver goes from active to inactive, a courtesy beep and hang time will be generated. It is required that the radios on a repeater port be only full duplex.

To convert a port into a repeater port the following command is used

```
000 X X
```

Where X and X are the same number indicating what port the repeater is on

When the port is looped back the courtesy beep is on port 'X', ID's are started and routed to port 'X'. Time-out timers, if enabled, are running when port 'X's receiver is active.

### **Link**

A link is defined as a port that does not loop the ports receive audio out the ports transmitter. When the receiver becomes active, the transmitters of all connected ports should go active except its own port. A link can be either half or full duplex. Full duplex links allow the ports transmitter to operate without effecting the receivers function. Half duplex links are similar to full duplex with the exception that the transmitters operation causes the receiver to be shut-off.

To convert a port into a link port the following command is used

```
002 X X
```

Where X and X are the same number indicating what port the link is on

When the port is a link the courtesy beep is on port 'X' is only routed to port 'X' if the audio routing variable is not 00 (Refer to Command 064 for audio routing variables). ID's are enabled but only controlled by the other connected ports. Time-out timers, if enabled, are running when port 'X's receiver is active.

### **Monitoring a port**

It is handy to monitor a connected ports receiver without keying the ports transmitter. Because the controllers full duplex ports, the controller can be monitoring another ports receiver while the monitoring port continues to have a conversation.

To monitor a port from another port the following command is used

```
001 X Y
```

Where X is the port doing the monitoring of port Y, Y is the port being monitored

## Example 2-2: Enable Time-Out Timers

Time out timers are a legal requirement on repeater system. The controller supports separate time-out timers on each receiver port. The time-out timer is assigned to a receiver, not the transmitter. Because the transmitter is keyed-up more continuous than the receivers, and because the time-out timers need a break in activity in order to reset their timers, the receivers are used as the control function. Because of this each port that is able to control the radios transmitter has a time-out timer. It is standard to configure the timers for 3 minutes of activity cause a time-out.

- 1) Enable all ports time-out timers
- 2) Program the time-out timers for 3 minutes

Enable all port time-out timers:

Command 010 is assigned to control each ports time-out timer. This command requires 2 digits of additional data to configure the command. The first digit is the port requested, the second is the control variable.

Port 1:	010 1 1 D or unkey	; Time-out timer enabled
Port 2:	010 2 1 D or unkey	; Time-out timer enabled
Port 3:	010 3 1 D or unkey	; Time-out timer enabled
Port 4:	010 4 1 D or unkey	; Time-out timer enabled on autopatch calls
Port 5:	010 5 1 D or unkey	; Time-out timer enabled on control receiver

Program the time-out timers for 3 minutes

Command 052 programs the timers on the controller. Timers 05..09 are assigned for the separate time-out timers. These timers are programmed in 10sec. increments. 3 minutes = 10 sec. \* 018. This command requires 5 digits of additional data to configure the command. The first two digits select what timer you are programming, the next 3 program the time from 001..999.

Port 1:	052 05 018 D or unkey	; Time-out timer time at 3 minutes
Port 2:	052 06 018 D or unkey	; Time-out timer time at 3 minutes
Port 3:	052 07 018 D or unkey	; Time-out timer time at 3 minutes
Port 4:	052 08 018 D or unkey	; Time-out timer time at 3 minutes
Port 5:	052 09 018 D or unkey	; Time-out timer time at 3 minutes

Time-out timers are now all enabled and set for 3 minutes. If the timer expires, all transmitters the port that timed out will be disabled for the timed out port. When the ports receiver goes from active to inactive, connected transmitters will now again be enabled to carry the ports signal.

Time-out timer messages:

Each port contains its own custom time-out timer event. These events are called when the port times out, and again when the port comes out of a timed out condition. Refer to commands 063,064,065 to program the event tables events.

## ***Example 2-3: Configuring a Ports COR/PL Polarity***

In order for the controller to recognize a ports receiver:

The receivers COR signal is used to tell the controller when the receiver is active

An external decoder can be used to decode a receivers CTCSS 'PL' tone for controller access

Each one of these signals can be either high when active, or low when active.

### **What 'High' really means**

A 'High' COR or PL signal indicates the input goes from a ground (0Volts) to either an open (High Z) or to a voltage above 4 volts. The controller has protection that safely allows 'High' voltages up to 15 volts without any damage to the controller. With a voltage meter you will read a voltage on the COR and PL inputs with nothing connected. This indicates the input is 'Pulled Up'. An input is 'pulled up' so the controller always has a voltage on the COR and PL inputs. This keeps the inputs from floating between 'High' and 'Low'

If you do not have a receiver connected to the controller, the controller will treat the COR and PL active high. It is very important to tell the controller the COR and PL inputs are active low if nothing is connected to the port.

### **What 'Low' really means**

A 'Low' COR or PL signal indicates the input goes from an open or a voltage above 4 volts to ground (0Volts). Ground does not mean open or nothing connected to a pin. Ground means just that, ground or the same voltage and impedance as your power supply (-) terminal. The controller has protection that safely allows 'High' voltages up to 15 volts without any damage to the controller.

If you do not have a receiver connected to the controller, the controller will treat the COR and PL active high. It is very important to tell the controller the COR and PL inputs are active low if nothing is connected to the port.

### **Polarity Control**

Once you have determined the ports COR and PL polarity you need to configure the controller to accept the correct polarities. The controller defaults to active 'Low' on both the COR and PL inputs of all ports. If your receivers are already 'Low' you do not need to change the configuration. If you polarity is active 'High', you need to execute Command 024 and tell the controller your correct polarity.

Active 'High' COR and active 'Low' PL (Or no PL at all) on Port 1 is configured as:

024 1 1 D or unkey (Refer to command 024 for more information)

This configured port 1 for active 'High' COR and active 'Low' PL

## ***Chapter 3: System Audio Control***

This chapter deals with the system audio controls. In this chapters commands that deal with audio routing of messages, execution of commands based on the audio routing, and how errors are spoken when encountered.

## ***003: User Control if Errors are Spoken***

This command allows the users to enable\disable the speaking of errors. Errors are sent if the format of the input data is not as the command requested requires.

```
<003> x
```

### **Parameters:**

- X - the Control variable
- 1 - enables errors to be spoken
- 0 - disables error to be spoken

### **Defaults:**

Errors speaking is enabled.

### **Error Codes:**

E1 - Invalid port requested  
(System wide errors are listed in front of the manual)

### **Example 1:**

I want to disable the errors from being spoken

```
003 0 D or unkey
```

### **Response:**

"Error Squawk <ON\OFF>"

## 007: Set Up the System's Audio Routing Variables

This command allows the user to set-up the system audio routing variables. These variables tell the controller where to route messages when commands are executed. This allows the user to totally control where CW and Voice messages are routed.

```
<007> xx yy
```

### Parameters:

XX is the audio routing slots

YY is the audio routing variable calculated below

Device that Executed the Commands (XX)	Audio Routing Variable
00: Internal Audio Routing Variable	01: Route to Port 1
01: RS-232 port	01: Route to Port 1
02: Not Used	01: Route to Port 1
03: Port 1	01: Route to Port 1
04: Port 2	02: Route to Port 2
05: Port 3	04: Route to Port 3
06: Autopatch	08: Route to Port 4
07: Control Receiver	01: Route to Port 1
08: Event Table	00: Use the routing variable in the event

Calculation of the audio routing variable:

The audio routing variable is calculated by adding up a number that corresponds to the port you want the response to be routed to. This number ranges from 00..31.

DTMF Executing the Command	Number that corresponds to the device
Port 1	+1
Port 2	+2
Port 3	+4
Autopatch	+8
Control Receiver	+16

(YY) Audio routing variable = (port1)+(port2)+(port3)+(autopatch)+(control rx)

**Error Codes:**

E1 - Invalid audio routing source

E2 - Audio routing variable too big. Must range from 00..31

(System wide errors are listed in front of the manual)

**Example 1:**

I want all commands executed from Port 3 to be routed out both Port 3 and Port 1.

1) Look-up port 3's audio routing slot.

Slot 05 is port 3

2) Develop an audio routing variable that includes port 1,3

Audio Routing Variable = 1(Port 1)+0(Port 2)+4(Port 3)+0(Autopatch)+0(Control) = 05

3) Execute Command 007

007 05 05 D or unkey

**Response:**

'Port' is 'Audio Routing Variable'



## ***008: Recall the System's Audio Routing Variables***

This command recalls the settings programmed in Command 007.

```
<008> xx
```

### **Parameters:**

XX is the audio routing slots. This number must range from 00..12

### **Defaults:**

There are no defaults for this command

### **Error Codes:**

E1 - Invalid audio routing source

(System wide errors are listed in front of the manual)

### **Example 1:**

I want to see what the audio routing variable is for the autopatch port

```
008 06 D or unkey
```

### **Response:**

"Slot is ARV"

## 039: Change the Internal Audio Routing Variable

This command allows the user to change where messages are routed that are called from internal execution sources. Internal execution sources include macros and internal generated messages and errors.

```
<039> xx
```

### Parameters:

XX is the audio routing variable. This number must range from 00..43

DTMF Allowed Execution of the Command	Number that corresponds to the device
Port 1	+1
Port 2	+2
Port 3	+4
Autopatch	+8
Control Receiver	+16

(XX) Audio routing variable = (port1)+(port2)+(port3)+(autopatch)+(control rx)

### Defaults:

Internal audio routing variable is port 1 (XX=01)

### Error Codes:

E1 - Invalid audio routing variable

### Example 1:

I want all internal responses to be routed to port 2, not port 1.

```
039 02 D or unkey
```

### Response:

There is no response for this command.

- To check your programming execute Command 008 00.

## ***020: Port DTMF Mute Control***

This command allows the user to control the DTMF mute function on a ports transmitter. When the mute is enabled for a transmitter, no DTMF tones will be re-broadcasted out the transmitter. If the port is a link, and you have enabled DTMF mute for that ports transmitter, then the PTT along with the audio will be muted when a DTMF is received. This only applies if the port is a link. On repeater ports, only the audio is muted, not the PTT.

```
<020> x y
```

### **Parameters:**

X is the port. This number ranges from 1..5  
Y is the control information.

- 1 - Enables DTMF mute on the transmitter
- 0 - Disables DTMF mute on the transmitter

### **Defaults:**

All ports DTMF mute is off.

### **Error Codes:**

E1 - Invalid port. Port must range from 1..5

E2 - Invalid access mode. Modes are listed above.

(System wide errors are listed in front of the manual)

### **Example 1:**

I want DTMF mute enabled on port 1 transmitter.

```
020 1 1 D or unkey
```

### **Response:**

"Port <ON/OFF>"

## ***021: Check Port Mute Controls***

This command check the settings of Command 020.

```
<021> x
```

### **Parameters:**

X is the port. This number ranges from 1..5

### **Defaults:**

All ports DTMF mute is off.

### **Error Codes:**

E1 - Invalid port. Port must range from 1..5

(System wide errors are listed in front of the manual)

### **Example 1:**

Receivers seem to be muting when they talk loud. I need to see if DTMF mute is enable for port 2's receiver.

```
021 2 D or unkey
```

### **Response:**

"Port <ON/OFF>"

## 022: *Set-up DTMF Cover Tone Variables*

This command allows the user to set-up the DTMF cover tone frequencies and if a cover tone is used when muting the DTMF tones

### Setting up the Cover tone enable/disable

```
<022> x
```

### Setting up to Cover tone frequencies

```
<022> xxxx yyyy
```

#### Parameters:

X is the control variable (When setting up Cover tone enable/disable)

- 1 - enables cover tone when DTMF mute active
- 0 - disables cover tone when DTMF mute active

XXXX and YYYY is the cover tone frequency counts (See Appendix B)

#### Defaults:

- Cover tone is enabled
- Cover tone frequency is 1000Hz

#### Error Codes:

E1 - Invalid tone frequency

E2 - Invalid Cover tone mode

(System wide errors are listed in front of the manual)

#### Example 1:

I want a cover frequency of 1000 Hz and 1500 Hz.

```
022 1000 0665 D or unkey
```

#### Response:

Either "ON/OFF" when controlling cover tone or "Frequency is XXXX and YYYY"

## *Chapter 3 Examples*

## ***Example 3-1: RLC-2 Audio Routing Variables***

In order for your voice/cw/dvr messages to be routed where they are intended to go, you need a good understanding of audio routing variables and their function.

Defining the system audio routing variables is accomplished using Command 007. This command lists the sources involved with executing commands.

### **Command 007 definitions:**

Variable 00 define internal events. Internal events are messages that are requested from the internal audio routing variable. Run-time access to this variable is accomplished using Command 039. This variable is mainly not used. Applications for this variable is you want a message routed to places other than the port that executed the event. Default routing of messages is the port that executed the command. The routing defaults to 01, Port 1

Variable 01 defines serial events. When commands are executed from the serial port the responses are routed to the serial port, along with any combination of radio ports. This variable defaults to 01, Port 1. If you enter a variable of 00, the messages will only be routed to the serial port and no other ports.

Variable 02 defines scheduler events. This event is not used. The scheduler events enter the routing variables to be used when the scheduler event is entered using Command 064. You should never have to change this variable. It defaults to 01, Port 1

Variable 03 defines execution from Port 1. This variable defaults to routing responses out only Port 1. It defaults to 01.

Variable 04 defines execution from Port 2. This variable defaults to routing responses out only Port 2. It defaults to 02.

Variable 05 defines execution from Port 3. This variable defaults to routing responses out only Port 3. It defaults to 04.

Variable 06 defines execution from Port 4 (Autopatch). This variable has 2 uses. First, it routes ring signals to the correct port when in reverse patch mode 1, second it controls where messages are routed when programming in reverse autopatch mode 2. Before programming this variable determine what mode your reverse autopatch will be operating in. Mode 1 typically is set to 01 (Route ringing out port 1) and mode 2 typically is set to 08 (Route message responses out the autopatch port). This variable defaults to routing responses out only the autopatch. It defaults to 08.

Variable 07 defines execution from Port 5. Because port 5 is a receive only port, its responses must be routed to a different port. This variable defaults to routing responses out only Port 1. It defaults to 01.

Variable 08 defines execution from the event table. This variable is a master variable that overrides the audio routing variables that are entered with every event. When this variable is set to 00, the audio routing information that is part of the event will be used. If you change this audio routing variable to something other than 00, the value entered with Command 007 will contain the routing information. It defaults to 00, use the audio routing information from the event tables events.

Variable 09..11 are not used

**Event table audio routing definitions:**

The event tables audio routing variables work similar to Command 007's variables with a few exceptions.

**Exception 1:**

If the audio routing variable entered for an event is 00, the audio is routed to the source that executed the command. If the serial port executes a command with a routing variable of 00, the response is routed out only the serial port. If a DTMF channel executes the same command, the response will be routed out the DTMF's channel.

**Exception 2:**

If Command 039 is present in the event tables execution. This command can change the routing of messages to selected ports thus bypassing all preset audio routing variables.

**Conclusion:**

Normal audio routing variables route to radio ports. Event audio routing is the same except you can assign three special cases that give more flexible routing to commands.



### ***Example 3-2: I want to enable DTMF muting on port 1,3***

I want to enable DTMF muting on ports 1 and 3, but not on port 2. Port 2 connects to a link system that needs to receive all DTMF codes entered.

Command 020 controls the enable or disable of selected ports for mute control. The format of the command requires 2 digits of control data entered in order for the command to execute correctly. The first data is the port number, the second is the control variable.

Port 1 control:

020 1 1 D or unkey ; This enables muting on Port 1

Port 2 control:

020 2 0 D or unkey ; This disables muting on Port 2

Port 3 control:

020 3 1 D or unkey ; This enables muting on Port 3

### ***Example 3-3: I want to disable DTMF cover tone on muted ports***

When the user enables DTMF muting the controller inserts a cover tone to break the silence of the muting action. The feature is nice so users do not key-up on you while you are programming the controller. Without the cover tone, the general user hears only silence. With the cover tone the general user hears a repeating tone beacon while DTMF data is being entered. The controller defaults the cover tone enabled.

To disable the mute control:

022 0 D or unkey ; Tone cover is now disabled. Only audio mute is enabled

## ***Chapter 4: System Security***

This chapter deals with system security and command name execution controls. Because all ports have the ability to access the commands in the controller, certain provisions are needed to protect execution.

## ***004: Setting Up the Master System Unlock Codes***

The controller supports 2 types of password system.

- **Type 1: Fixed password length from 1..15 digits**  
 Passwords length is determined by the number of digits you enter with Command 004. If you want a 4 digit password, simply enter 4 additional digits when programming. The limits to this style of access is if someone figures out your password they can access the controller. Fixed password access is available with Command 026
- **Type 2: Challenged password with 4 digits entered from a table of 16 digits**  
 Password length is fixed to 4 digits. These 4 digits are requested by the controller when executing Command 005. The controller will speak "Please Enter Code X X X X". 'X' corresponds to a number in the table of user entered numbers. Command 004 is used to enter these user defined digits.
- When the user requests access to certain commands, and the controller speaks "Error 7", this indicates the need to unlock the controller before execution of the command is allowed. The user must execute Command 005 (Challenged Passwords) or Command 026 (Fixed Passwords) in order to unlock the controller. These codes are programmed with this command.

**<004> (See Below for challenged Passwords)**

or...

**<004> x..x (Fixed Passwords)**

### **Parameters:**

**Fixed Passwords:**

X..X is the fixed password that ranges from 1 to 15 digits

**Challenged Passwords:**

The user must enter 16 digits from the DTMF pad. The digits can be any valid DTMF digit. It is very important to remember these codes for they access the master unlock command. If you forget the digits, and try to access a locked command, then re-initialization of the controller is the only way to access the command.

***Challenged Password Look-up Table:***

Requested Digits	Default Digits	User Entered Digits
0	1	
1	2	
2	3	
3	4	
4	5	
5	6	
6	7	
7	8	
8	9	
9	#	
10	#	
11	1	
12	2	
13	3	
14	4	
15	5	

**Error Codes:**

(System wide errors are listed in front of the manual)

**Example 1:**

I want to change the access codes to my own codes

004 ABC\*1234###94123

**Response:**

The controller will not speak back the codes for security.

"System Lock Codes O K"

## 005: *Unlocking the Controller with Challenged Passwords*

This command allows the user to unlock the controller for accessing locked commands. This command only works if you have set-up the system for challenged passwords. The user will execute Command 005 and the controller will request unlock codes. These codes can be embedded with garbage codes for added security. The controller only requires the 4 requested codes to be entered in the requested sequence. Refer to Command 004 to program the access password.

User: Request password

<005>

**Controllers voice: " Please enter code # # # #"**

User enters the password to unlock the controller

<005>...PPPP...

**Controllers voice: "System Lock On" If the wrong password entered**

**or**

**Controllers voice: "System Lock Off" If the correct password entered**

### Parameters:

...PPPP... is the password information. The '...' indicate garbage data can be entered before and after the group of password data is entered.

### Defaults:

The password defaults are listed in Command 004's table.

### Notes:

- Please note the password if you change it. Serial can bypass the unlock sequence if specified. If you do not note the password table, the serial may be able to change the table if Command 004 is not locked on the serial port.

### Error Codes:

(System wide errors are listed in front of the manual)

### Example 1:

The user enters Command 005 to get a password and the controller states codes 1,3,5,9 are needed. The user enters the following.

005 34512 1 3 5 9 #AB1239

The data '34512' and '#AB1239' is garbage data. The codes '1 3 5 9' is the correct password. The controller responds 'Controller Lock Off' indicating the lock is now disabled.

### Response:

"Controller Lock Off" or "Controller Lock On" or "Please enter Code # # # #"

## ***026: Unlocking the Controller with Fixed Passwords***

This command allows the user to unlock the controller for accessing locked commands. This command only works if you have set-up the system for fixed passwords. The user will execute Command 026 followed by the fixed password that was entered with Command 004. Refer to Command 004 to program the access password.

User enters the password to unlock the controller

<026> P..P

**Controllers voice: "System Lock On" If the wrong password entered**

**or**

**Controllers voice: "System Lock Off" If the correct password entered**

### **Parameters:**

P..P is the password information. This password can range from 1..15 digits depending on what the user entered with Command 004.

### **Defaults:**

The password system is set-up for challenged passwords.

### **Notes:**

- Please note the password if you change it. Serial can bypass the unlock sequence if specified. If you do not note the password table, the serial may be able to change the table if Command 004 is not locked on the serial port.

### **Error Codes:**

(System wide errors are listed in front of the manual)

### **Response:**

"Controller Lock Off" or "Controller Lock On"

## ***006: Locking the Controller***

This command locks the controllers access. Once the controller is locked the unlock sequence must be re-entered in order to gain access to locked commands.

<006>

**Parameters:**

There are no parameters for this command.

**Defaults:**

the controller defaults locked

**Error Codes:**

(System wide errors are listed in front of the manual)

**Example 1:**

The user is finished with programming and wants to re-lock the controller.

006 D or unkey

**Response:**

"Controller Lock On"

## 027: *Rename DTMF Command Name*

This command allows the user to rename commands using the 3 digit command number as the look-up indicator.

```
<027> xxx y..y
```

### Parameters:

XXX is the command number that ranges from 000..245

Y..Y is the 1-6 digit command name

The command name can contain any of the 16 DTMF digits.

The command names can be up to 6 digits in length

### Defaults:

The command names correspond to the command numbers.

### Notes:

- It is important not to name 2 different command names the same name. If you do this the first command name matched will be executed. The controller scans from command number 000 to find a matching command name. If you rename 2 command names the same simply rename the later command name to a different name.
- The controller scans for name matches beginning with 6 digits down to single digit matches. When the controller finds a possible name match it compares the additional data that is present with the command name to what the controller expects that command names additional data needs. This matching sequence allows command names that are similar to be executed separately. For example: A command name '#' and '#12 with data 13 14' will be executed differently. The controller will match '#' because it does not need additional data and will match '#12' with its command name because it needs 4 digits of additional data.

### Error Codes:

E1 - Invalid command number. Number ranges from 000..245

E2 - Not enough data present

(System wide errors are listed in front of the manual)

### Example 1:

I want to rename my autopatch hangup to '#'

```
027 146 # D or unkey
```

### Response:

"Command Number is <Command Name>"



## ***028: Command Read Back by Command Number***

This command allows the user to recall a command name using the command number as the look-up source. This is handy when the command name is not know. The command number never changes so it is therefore a constant that can always be used as a reference.

```
<028> xxx
```

### **Parameters:**

XXX is the command number that ranges from 000..245

### **Defaults:**

The command names correspond to the command numbers.

### **Error Codes:**

E1 - Invalid command number. Number ranges from 000..245

E2 - Not enough data present

(System wide errors are listed in front of the manual)

### **Example 1:**

I need to recall what I named my autopatch hang-up code. The command number is 146.

```
028 146 D or unkey
```

### **Response:**

"Command Number is <Command Name>"

## ***029: Command Name Compare to Find Command Number***

This command allows the user to recall a command number using the command name as the look-up source. This is handy when the command number is not know. The command number never changes so it is therefore a constant that can always be used as a reference.

```
<029> x..x
```

### **Parameters:**

X..X is the command name

### **Defaults:**

The command names correspond to the command numbers.

### **Error Codes:**

E1 - Invalid command name.

(System wide errors are listed in front of the manual)

### **Example 1:**

I need to recall what the command number is for my autopatch hang-up.

```
029 # D or unkey
```

### **Response:**

"Command Number is <Command Name>"

## ***030: Change First,Second,Third Command Name Digits***

This command allows the user to change the first, second, and third digits of a group of command names. This command is used when a group of commands needs a common part of the command name changed. This will not effect the command numbers (first 3 digits of the command name).

```
<030> xxx yyy z..z
```

### **Parameters:**

XXX is the beginning command number that ranges from 000..245

YYY is the ending command number that ranges from 000..245

Z..Z is the digits to assigned to the group of commands.

### **Defaults:**

The first 3 digits of these command names are not defined. All command names are 3 digits in length referenced by the command number.

### **Error Codes:**

(System wide errors are listed in front of the manual)

### **Example 1:**

I want to make all my commands begin with the DTMF digit 'C'

```
030 000 245 C D or unkey
```

### **Response:**

"First command number is <Command Addition>, Second command number is <Command Addition>"

## 031: Group Assign DTMF Command Mask Assign

This command allows the user to assign a DTMF execution mask to a group of commands. Use of this command allows the control operator the ability to keep certain ports from executing certain commands and/or all commands.

```
<031> xxx yyy zz
```

### Parameters:

XXX is the beginning command number ranging from 000..245

YYY is the ending command number ranging from 000..245

ZZ is the audio routing variable used to allow access to certain commands

DTMF Allowed Execution of the Command	Number that corresponds to the device
Port 1	+1
Port 2	+2
Port 3	+4
Autopatch	+8
Control Receiver	+16

(ZZ) Audio routing variable = (port1)+(port2)+(port3)+(autopatch)+(control rx)

### Defaults:

All ports can execute all commands (ZZ=31)

### Error Codes:

E1 - Digit Counters do not match. Check the number of digits entered for this command.

E2 - Invalid command number. Command numbers range from 000..245

E3 - Invalid audio routing variable. Variables range from 00..31

(System wide errors are listed in front of the manual)

### Example 1:

I have a remote base on port 3..I do not want this radio to execute any DTMF commands.

(ZZ) Audio routing variable = 1(port1)+2(port2)+0(port3)+8(autopatch)+16(control rx)

```
031 000 245 27 D or unkey
```

### Response:

"First command number is <DTMF Mask>, Second command number is <DTMF Mask>"

## 032: Command Checks Value of DTMF Execution Register

This command checks the results of Command 31 on individual command numbers.

<032> xxx

**Parameters:**

XXX is the command number ranging from 000..245

**Defaults:**

All ports can execute all commands (ZZ=31)

**Error Codes:**

E1 - Invalid command number. Command numbers range from 000..245  
 (System wide errors are listed in front of the manual)

**Example 1:**

I can not execute the "Check cross-point" command 009. I need to see if I am enabled to execute that command.

032 009 D or unkey

**Response:**

DTMF Allowed Execution of the Command	Number that corresponds to the device
Port 1	+1
Port 2	+2
Port 3	+4
Autopatch	+8
Control Receiver	+16

(ZZ) Audio routing variable = (port1)+(port2)+(port3)+(autopatch)+(control rx)

### ***033: Group Assign Master Unlock Requirement for DTMF***

This command allows the user to assign lock code requirements for a group of commands. This only effects the DTMF lock/unlock assignment. Serial lock assignments are programmed starting with Command 036.

To gain access to a locked command the controller must be unlocked. See Command 004,005, and 006 for unlock control.

```
<033> xxx yyy z
```

#### **Parameters:**

XXX is the beginning command number ranging from 000..245

YYY is the ending command number ranging from 000..245

Z is the control function

1 - requires an unlock before execution

0 - does not require an unlock before execution

#### **Defaults:**

All commands are unlocked

#### **Notes:**

- Command 005, the unlock command can never be locked. If it could be locked access to the controller could never be possible.

#### **Error Codes:**

E1 - Invalid command number. Command numbers range from 000..245

E2 - Invalid control variable. Variables range from 0..1

(System wide errors are listed in front of the manual)

#### **Example 1:**

I want all programming commands except macros, to require the unlock code entered.

```
033 000 170 1 D or unkey
```

#### **Response:**

"First command number is <ON/OFF>, Second command number is <ON/OFF>"

## ***034: Individually Assign Unlock Requirement for DTMF***

This command allows the user to assign lock code requirements for individual commands. This only effects the DTMF lock/unlock assignment. Serial lock assignments are programmed starting with Command 036.

To gain access to a locked command the controller must be unlocked. See Command 004,005, and 006 for unlock control.

```
<034> xxx y
```

### **Parameters:**

XXX is the command number ranging from 000..245

Z is the control function

1 - requires an unlock before execution

0 - does not require an unlock before execution

### **Defaults:**

All commands are unlocked

### **Notes:**

- Command 005, the unlock command can never be locked. If it could be locked access to the controller could never be possible.

### **Error Codes:**

E1 - Invalid command number. Command numbers range from 000..245

E2 - Invalid control variable. Variables range from 0..1

(System wide errors are listed in front of the manual)

### **Example 1:**

I want to allow execution of 'Time-of-Day Reading'

```
034 055 0 D or unkey
```

### **Response:**

"Command number is <ON/OFF>"

## ***035: Recall DTMF Unlock Requirements on a Command***

This command checks the results of Commands 33,34.

```
<035> xxx
```

### **Parameters:**

XXX is the command number ranging from 000..245

### **Defaults:**

All commands are unlocked

### **Notes:**

- Command 005, the unlock command can never be locked. If it could be locked access to the controller could never be possible.

### **Error Codes:**

E1 - Invalid command number. Command numbers range from 000..245

(System wide errors are listed in front of the manual)

### **Example 1:**

I keep getting an Error 7 when I try to read the time-of-day clock, Command 055. Why??

```
035 055 D or unkey
```

The lock is enabled for this command. Execute Command 005 to unlock the controller then try to execute the command.

### **Response:**

"Command number is <ON/OFF>"



# 036: Group Assign Master Unlock Requirement for Serial

This command allows the user to assign lock code requirements for a group of commands. This only effects the Serial lock/unlock assignment. DTMF lock assignments are programmed starting with Command 033.

To gain access to a locked command the controller must be unlocked. See Command 004,005, and 006 for unlock control.

```
<036> xxx yyy z
```

**Parameters:**

- XXX is the beginning command number ranging from 000..245
- YYY is the ending command number ranging from 000..245
- Z is the control function
  - 1 - requires an unlock before execution
  - 0 - does not require an unlock before execution

**Defaults:**

All commands are unlocked

**Notes:**

- Command 005, the unlock command can never be locked. If it could be locked access to the controller could never be possible.

**Error Codes:**

- E1 - Invalid command number. Command numbers range from 000..245
- E2 - Invalid control variable. Variables range from 0..1  
(System wide errors are listed in front of the manual)

**Example 1:**

I want all programming commands except macros, to require the unlock code entered.

```
036 000 170 1 D or unkey
```

**Response:**

"First command number is <ON/OFF>, Second command number is <ON/OFF>"

## ***037: Individually Assign Unlock Requirement for Serial***

This command allows the user to assign lock code requirements for individual commands. This only effects the Serial lock/unlock assignment. DTMF lock assignments are programmed starting with Command 036.

To gain access to a locked command the controller must be unlocked. See Command 004,005, and 006 for unlock control.

```
<037> xxx y
```

### **Parameters:**

XXX is the command number ranging from 000..245

Z is the control function

1 - requires an unlock before execution

0 - does not require an unlock before execution

### **Defaults:**

All commands are unlocked

### **Notes:**

- Command 005, the unlock command can never be locked. If it could be locked access to the controller could never be possible.

### **Error Codes:**

E1 - Invalid command number. Command numbers range from 000..245

E2 - Invalid control variable. Variables range from 0..1

(System wide errors are listed in front of the manual)

### **Example 1:**

I want to allow execution of 'Time-of-Day Reading'

```
037 055 0 D or unkey
```

### **Response:**

"Command number is <ON/OFF>"

## ***038: Recall Serial Unlock Requirements on a Command***

This command checks the results of Commands 33,34.

```
<038> xxx
```

### **Parameters:**

XXX is the command number ranging from 000..245

### **Defaults:**

All commands are unlocked

### **Notes:**

- Command 005, the unlock command can never be locked. If it could be locked access to the controller could never be possible.

### **Error Codes:**

E1 - Invalid command number. Command numbers range from 000..245

(System wide errors are listed in front of the manual)

### **Example 1:**

I keep getting an Error 7 when I try to read the time-of-day clock, Command 055. Why??

```
037 055 D or unkey
```

The lock is enabled for this command. Execute Command 005 to unlock the controller then try to execute the command.

### **Response:**

"Command number is <ON/OFF>"

## ***040: User Forced Execution Digit Change***

This command allows the changing of the forced execution digit. This digit forces the execution of the commands entered before the receiver drops. Uses of this digit is the shut-off a receiver when the COR is stuck open, a jammer needs to be shut-off, quicker access to commands, and the list goes on.

<040> x

### **Parameters:**

X is the new DTMF forced execution digit

### **Defaults:**

The forced execution digit is the 'D'

### **Notes:**

- It is important not to define the forced execution digit to a commonly used DTMF digit. Once the DTMF digit is defined as being the forced execution digit, it can no longer be used for system wide applications. Typical DTMF digits used are '\* A B C D'.

### **Error Codes:**

(System wide errors are listed in front of the manual)

### **Example 1:**

I need the EOF digit to be a '\*' so I can use the 'D' in command names.

040 \* D or unkey

### **Response:**

"Condition Entered With A <Forced Execution Digit>"

## ***041: Check the Forced Execution Digit***

This command checks the current setting of the forced execution digit.

```
<041>
```

### **Parameters:**

There are no parameters for this command

### **Defaults:**

The forced execution digit defaults to a 'D'

### **Error Codes:**

(System wide errors are listed in front of the manual)

### **Example 1:**

I need to check the forced execution digit before I begin programming

```
041 D or unkey
```

\* Note: The 'D' in the above example is the forced execution digit. If the digit is actually a '\*' then the command entry would look like.

```
041 * or unkey
```

### **Response:**

"Condition Entered With A <Forced Execution Digit>"

## *115: Assign the DTMF Decoder Priority*

This command gives the controller the ability to assign highest priority to the DTMF decoder. When a port is assigned as highest priority, its activity determines where the DTMF decoder will be located for code input. Normally this port is "Port 5" the control receiver. This command is not discriminate. When the priority port is active, the decoder is changed to this port, regardless of data entry on the currently active port

```
<115> x
```

**Parameters:**

X is the radio port priority

DTMF Allowed Execution of the Command	Number that corresponds to the device
No Priority	0
Port 1	1
Port 2	2
Port 3	3
Autopatch	4
Control Receiver	5
Reverse Autopatch	6

**Defaults:**

(X) is set for the control receiver

**Error Codes:**

E1 - Invalid radio port. Number must range between 1..5  
 (System wide errors are listed in front of the manual)

**Example 1:**

I want Port 3 to become DTMF priority.

```
115 3 D or unkey
```

**Response:**

"Radio Select <Radio Port>"

## *Chapter 4 Examples*

## ***Example 4-1: Accessing Locked Commands when in Challenged Password Mode***

The controller has a high security lock-out mode that keeps unwanted users from accessing certain commands. When the controller is un-locked, all commands can be accessed without security. This opens the programming of the controller up to anyone. Therefore the controller has the feature of locking access to any or all of the controllers commands. The only way to access these commands is by entering the correct unlock codes. Once the controller is unlocked open programming is again possible.

How to tell the controller to unlock:

The controllers unlock command is a challenging unlock code. When the user wants access to the locked commands, simply enter Command 005. This command will respond with the unlock code request. The voice message is 'Please Enter Code X X X X'. 'X X X X' refers to the numbers entered into the access code table (See Command 004). In order to unlock the controller the user must re-enter Command 005 followed by 'X X X X'. If the controller locates these codes correctly it will unlock the controller by speaking 'System Lock Off'. If the codes requested by the controller are incorrect, the controller will respond with the response 'System Lock On'. If you mess-up entering the codes simply execute Command 005 again and the controller will request another set of codes. The controller will never request the same codes twice in a row, and the code numbers will never be the same in the request. For example the controller will never request '1, 4, 4, 15' because there are 2-4's in the-4's in the same request.

For security the user can embed the requested unlock code in a string of garbage data up to 100 DTMF digits in length. If the controller requests the unlock code '1 5 A 3' the user can enter the sequence '1 5 A 3' or '1 2 8 5 4 1 5 A 3 4 6 1 2' and the controller will unlock programming. If you notice the correct unlock code is present in the 13 digit sequence, but surrounded by garbage digits.

Once programming is complete, the user can lock the controller using Command 006. If the user forgets to lock the controller, the System Un-Lock timer (See Command 050,051,052) will automatically lock the controller. The lock timer is reset after every command is executed without any errors.



## ***Example 4-2: Renaming Commonly Used Commands***

In order for the controller to handle your system existing codes, the RLC-2 has the ability of renaming the command names from 1..6 digits. The command names can contain any of the 16 DTMF digits except the forced execution digit. This digit defaults to the 'D' key. All command names default to their command number. Command numbers range from 000..245. All internal programming that handle any command names uses the command number as the command request. This insures the controller does not need to busy itself by handling the command name that can be as big as 6 digits.

For example:

In a macro I need to recall a voice message (Command 045). I have renamed this command name to 1234AA. Inside the macro I will use the command number (045) not the name of 1234AA.

Rules to follow when deciphering the command name maze:

- 1) Use the 3 digit command numbers when the controller executes the command
- 2) Use the DTMF command name when executing from any of the radio\patch ports.
- 3) When executing from the serial port, use the command numbers, not the command names

Default Command Names:

All command names are initialized to their command number out of initialization. For example to execute Command 045 you enter 045 out of initialization. All of the manual pages that describe the commands functions begin with the commands command number.

Exceptions:

- 1) Autopatch dial command:
  - Command number = 143
  - Default command name = '\*'
  - Format: '\*' followed by the phone number
- 2) Autopatch hang-up command:
  - Command number = 146
  - Default command name = '#'
  - Format: '#' hangs the phone up
- 3) Autopatch last number entered redialed:
  - Command number = 148
  - Default command name = '\*\*'
  - Format: '\*\*' redials the last number entered
- 4) Autopatch reset time-out timer:
  - Command number = 149
  - Default command name = '\*\*3'
  - Format: '\*\*3' will restart the patch time-out timer to its entered value

### ***Example 4-3: Renaming Commands***

In order for the controller to handle your system existing codes, the RLC-2 has the ability of renaming the command names from 1..6 digits. The command names can contain any of the 16 DTMF digits except the forced execution digit. This digit defaults to the 'D' key. All command names default to their command number. Command numbers range from 000..245. All internal programming that handle any command names uses the command number as the command request. This insures the controller does not need to busy itself by handling the command name that can be as big as 6 digits.

Renaming commands using Command 027:

Command 027 allows the user to rename any command number to a unique command name. The format of the command:

027 XXX #.# D or unkey

Where 027 is the default command name of command 027

XXX is the command number needing the new command name

#.# is the new command name that ranges from 1 to 6 digits

Example: I want to recall my controller time using the code #83

1) Recall the time uses command number 055

2) Execute command 027

The format of the command:

027 055 #83 D or unkey

Where 027 is the default command name of command 027

055 is the recall time command

#83 is the new command name

Exceptions:

1) Command names can not contain the forced execution digit.

Forced execution digit defaults to the 'D' key

If you need to change the forced execution digit, do it before you name any commands that will contain the new forced execution digit.

2) Duplicate command names are not allowed

If you duplicate command names the controller will execute the first name that it comes to. The second instance will never be executed except by the serial port, and internal commands. If you accidentally name two commands the same name simply rename the duplicate command to another name using command 027.

Recalling command names is accomplished using commands 028 and 029

028 recalls the command name using the command number as the key

028 XXX D or unkey ; recalls command name of command number 'XXX'

029 recalls the command number using the command name as the key

029 #.# D or unkey ; recalls command number of command name '#.#'

### ***Example 4-4: Assigning DTMF, Un-Lock codes, Serial masks***

The RLC-2 supports assignment of several user options to determine who can execute commands and from what source. The 3 types of masks:

- **DTMF execution mask:** This mask is used to determine what ports can execute what commands. If you do not want certain ports from executing commands. Command 031 is provided to assign DTMF masks to a group of command numbers. All commands default to execution from all ports.

Format: Assign DTMF mask

031 XXX YYY ## D or unkey

Where 'XXX' is the first command number

'YYY' is the second command number

'##' is the execution mask (See Command 031)

If you only want to assign a DTMF mask to 1 command, then enter that command number for both 'XXX' and 'YYY'.

Example: I want port 3 no DTMF access to any commands

1) Calculate the mask (See Command 031)

- The mask value calculated:  $1 + 2 + 0 + 8 + 16 = 27$

2) Execute command 031:

- 031 000 245 27 D or unkey ; Allows DTMF execution from all ports except port 3

To check what DTMF execution mask is assigned to a command, see command 032.

- **Unlock codes for DTMF access:** This mask is used to determine what commands executed from DTMF can access programming commands only when the controller is unlocked. When the unlock code is assigned, the user must execute Command 005 before these commands can be executed. All commands default unlocked (No command 005 needed).

Format: Assign Unlock code for a group of DTMF accessed commands

033 XXX YYY # D or unkey

Where 'XXX' is the first command number

'YYY' is the second command number

'#' is the lock mask 1=lock, 0=unlock

Format: Assign Unlock code for an individual DTMF accessed command

034 XXX # D or unkey

Where 'XXX' is the command number

'#' is the lock mask 1=lock, 0=unlock

To check what unlock code is assigned to a command, see command 035.

Example: I want all commands from 000..142, 144,145 and 150..170 to require the unlock code be entered before accessing those commands

- 1) Execute command 033 for commands 000..142:  
- 033 000 142 1 D or unkey ; Require unlock code
- 2) Execute command 034 for commands 143  
- 034 143 0 D or unkey ; Command unlocked
- 3) Execute command 033 for commands 144..145:  
- 033 144 145 1 D or unkey ; Require unlock code
- 4) Execute command 033 for commands 146..149:  
- 033 146 149 0 D or unkey ; Commands unlocked
- 5) Execute command 033 for commands 150..170:  
- 033 150 170 1 D or unkey ; Require unlock code

This batch of commands only allows certain commands to be executed by the user. All other commands require the unlock code entered. Command 005 can never be locked. If this command were locked, the controller could never be unlocked.

- Unlock codes for serial port access: This mask is used to determine what commands executed only from the serial port can access programming commands only when the controller is unlocked.

Format: Assign Unlock code for a group of serial port accessed commands

036 XXX YYY # D or unkey

Where 'XXX' is the first command number

'YYY' is the second command number

'#' is the lock mask 1=lock, 0=unlock

Format: Assign Unlock code for an individual serial accessed command

037 XXX # D or unkey

Where 'XXX' is the command number

'#' is the lock mask 1=lock, 0=unlock

To check what serial unlock code is assigned to a command, see command 038.

Example: I want all commands execute from the serial port to require the unlock code be entered before accessing those comands

- 1) Execute command 036 for commands 000..245:  
- 036 000 245 1 D or unkey ; Require unlock code

This batch of commands only allows certain commands to be executed by the user. All other commands require the unlock code entered. Command 005 can never be locked. If this command were locked, the controller could never be locked.

### ***Example 4-5: Changing the <Forced Execution> Digit***

The controller supports a special DTMF digit called the forced execution digit. This digit is special in the case that it forces the controller to execute the entered digits when this digit is entered. The controller has 3 ways of causing commands to be executed.

- 1) Receiver drops and causes the DTMF digits, if any, to be executed
- 2) Timed execution. After the DTMF digits are entered, and if the receiver does not unkey before the timer assigned to the timed execution expires, the DTMF data is executed.
- 3) Forced execution digit is received. Upon receipt of this digit, the controller will execute the entered digits.

The forced execution digit defaults to the 'D' key. Because of the command executer the controller supports, and because the 'D' digit is not used very often, this digit as the enter digit. Other controllers, and earlier versions of software for this controller used the '\*' as the forced execution digit. With the new executer on the controller, the '\*' is defined for other purposes on the controller. Autopatch access begins with the '\*'.

'D' can not be used in any functions on the controller except in the pre-access system.

When choosing the forced execution digit, the user must keep in mind that the digit can not be used for any other function in the controller. If you are use to the '\*' as this digit, simply include the '\*' in your command name.

Reverse autopatch access can not use the 'D' unless you have a 16 digit phone system. If you do not then see Command 023 to enable timed execution. This seems to work well with the phone system.

Changing the forced execution digit.

- 1) Verify you do not use this digit in existing command names
- 2) Execute Command 040 followed by the new Forced digit
  - 040 X D or unkey
  - Where 'X' is you new forced execution digit
  - Response "Command Entered With A 'X' "

The controller defaults the forced execution digit as a 'D'

## ***Chapter 5: Messages, Tones and Responses***

This chapter deals with the programming, setup and sending of system voice, cw, and tone messages.

## 042: Generate a Tone Sequence Out Selected Ports

This command is what generates tone sequences for courtesy beeps, paging tones, DTMF regeneration and any function that uses a tone generated tone sequence.

### Custom developed tones

```
<042> xxxx yyyy ddd ppp
```

#### Parameters:

XXXX is the tone counts for frequency 1 (See Appendix B)

YYYY is the tone counts for frequency 2 (See Appendix B)

DDD is the length of the tone sequence in 10mS increments

PPP is the length of the delay between the next tone sequence in 10mS increments

### Pre-Programmed tones

```
<042> xx
```

#### Parameters:

XX is the pre-programmed tone sequence (See Below)

Tone Name	Number	Tone 1	Tone 2	Length	Pause
Bumble Bee	00	3029	0000	100mS	0mS
	00 cont.	1999	0000	100mS	0mS
	00 cont.	1514	0000	100mS	0mS
Yellow Jacket	01	3029	0000	50mS	0mS
	01 cont.	1999	0000	50mS	0mS
	01 cont.	1514	0000	50mS	0mS
Shooting Star	02	1135	0000	100mS	0mS
	02 cont.	1135	0000	100mS	0mS
	02 cont.	1850	0000	100mS	0mS
Comet	03	1999	0000	100mS	0mS
	03 cont.	1999	0000	100mS	0mS
	03 cont.	1332	0000	100mS	0mS

Stardust	04	1332	0000	120mS	0mS
	04 cont.	1135	0000	80mS	0mS
	04 cont.	0832	1135	80mS	0mS
Duncecap	05	2271	1999	200mS	0mS
	05 cont.	2271	2856	200mS	0mS
Dial Tone	06	2856	2271	100mS	100mS
Low-High Beep	07	2000	0000	100mS	0mS
	07 cont.	1500	0000	100mS	0mS
High-Low Beep	08	1500	0000	100mS	0mS
	08 cont.	2000	0000	100mS	0mS
Cover Tone	09	1000	0000	200mS	300mS
Audible Ring Tone	10	2271	2082	400mS	400mS

**Notes:**

- The tones are routed to the port that executed them. When a courtesy beep is requested from the event table (See Commands 63,64,65) the controller knows where to route the tones.

**Error Codes:**

E1 - Not enough data entered

E2 - Invalid pre-programmed tone slot

(System wide errors are listed in front of the manual)

**Example 1:**

I want to generate a pre-programmed beep #10

042 10 D or unkey

**Response:**

There is no voice response for this command



## 043: Generate a CW Message Out Selected Ports

This command generates the CW messages used by the controller.

<043> xx..xx

### Parameters:

XX..XX is the CW code table

CW	XX	.	CW	XX	.	CW	XX	.	CW	XX	.	CW	XX
0	0	.	A	10	.	K	20	.	U	30	.	SPACE	40
1	1	.	B	11	.	L	21	.	V	31	.	PAUSE	41
2	2	.	C	12	.	M	22	.	W	32	.		
3	3	.	D	13	.	N	23	.	X	33	.		
4	4	.	E	14	.	O	24	.	Y	34	.		
5	5	.	F	15	.	P	25	.	Z	35	.		
6	6	.	G	16	.	Q	26	.	/	36	.		
7	7	.	H	17	.	R	27	.	0	37	.		
8	8	.	I	18	.	S	28	.	?	38	.		
9	9	.	J	19	.	T	29	.	AR	39	.		

### Defaults:

CW speed defaults to 20 WPM

CW Frequency defaults to 1000HZ and 1500HZ

### Error Codes:

E1 - To much CW data

E2 - Invalid CW Character

(System wide errors are listed in front of the manual)

### Example 1:

I want to generate a CW message 'KF7FW/R'

043 20 15 07 15 32 36 27 D or unkey

### Response:

There is no voice response for this command

## 044: Generate a DTMF Sequence Out a Selected Port

This command allows the re-generation of DTMF tones down selected ports. With this command the user can send a DTMF data burst of up to 20 digits down any of the ports.

```
<044> xx yy..yy
```

### Parameters:

XX is the audio routing variable

DTMF Allowed Execution of the Command	Number that corresponds to the device
Port 1	+1
Port 2	+2
Port 3	+4
Autopatch	+8
Control Receiver	+16

(XX) Audio routing variable = (port1)+(port2)+(port3)+(autopatch)+(control rx)

YY is the DTMF digits

DTMF Digit	Number Entered	DTMF Digit	Number Entered
0	00	9	09
1	01	A	10
2	02	B	11
3	03	C	12
4	04	D	13
5	05	D	14
6	06	#	15
7	07	Pause	16
8	08		

### Defaults:

DTMF length = 100mS

DTMF pause = 100mS

**Notes:**

- When re-generating DTMF the controllers tone 1 and tone 2 need to adjusted correctly to provide to correct 'twist'. Most DTMF decoders are not picky about the twist factor. It is a good idea to adjust both tones to about the same level.
- DTMF re-generation length and pause is programmed with the timer commands (See Commands 50,51,52) for timer numbers.

**Error Codes:**

E1 - To many DTMF digits requested

E2 - Invalid DTMF digit. Digits must be between 00..16

(System wide errors are listed in front of the manual)

**Example 1:**

I want to send a DTMF string 'pause, pause, pause 96 C000 \* ' down port 3

```
044 04 16 16 16 09 06 12 00 00 00 14 D or unkey
```

**Response:**

DTMF digits is the only response

## 045: *Generate a Voice Message*

This command allows the generation of voice messages. These messages can be either impolite (Can not be interrupted), polite (Can be interrupted and the message is canceled) or polite with a message sent (Can be interrupted and the message is canceled, when the message is canceled an event in the event table is requested. This event can then generate a CW message or another voice message if needed). See Appendix C for the voice word table.

<045> xxx..xxx

### Parameters:

XXX..XXX are the voice words for speaking.

### Notes:

There two special words that effect how a voice message is spoken.

- Word 733: Indicates a polite message that when interrupted will cancel the voice message
- Word 734: Is the same as word 733 except when it is interrupted it requests an event from the event table. The user could send a CW message when the voice is interrupted.

### Error Codes:

E1 - To much or to little data entered

E2 - Incorrect voice word. See Appendix C for voice words

(System wide errors are listed in front of the manual)

### Example 1:

I want to speak the message

"At <Male Time> You Are On The Repeater, <Good MAE>"

AT	077
<Male Time>	701
You	480
Are	047
On	310
The	421
Repeater	361
Pause	528
<Good MAF>	700

045 077 701 480 047 310 421 361 528 700 D or unkey

### Response:

Response is what you typed in.

## ***046: Delete a Message Slot***

This command allows the deletion of certain message slots. This is useful when a message is no longer needed. When the message is deleted, there will be no key-ups or delays when the controller requests that message.

```
<046> xx
```

### **Parameters:**

XX is the message slot number. This number ranges from 01..33

### **Notes:**

- Once a message is deleted you must re-program the message. There is no way to undelete the message slot once it is deleted.

### **Error Codes:**

E1 - Invalid message slot

(System wide errors are listed in front of the manual)

### **Example 1:**

I need to delete message slot 15. It is no longer used

```
046 15 D or unkey
```

### **Response:**

"Cancel <Message slot number>"

## ***047: DTMF Keypad Message Generate***

This command allows the user to generate a voice message as a keypad test. Up to 20 keys can be entered to generate a voice message. The controller will respond with a voice message that is equivalent to the DTMF entered.

```
<047> x..x
```

### **Parameters:**

X..X are the DTMF digits entered

### **Defaults:**

There are no defaults for this command

### **Notes:**

- The "Forced Execution Digit" will never be spoken. All other 15 digits will be spoken

### **Error Codes:**

E1 - Too much or too little data entered

(System wide errors are listed in front of the manual)

### **Example 1:**

I want to test my keypad's DTMF digits

```
047 1 2 3 4 5 6 7 8 9 0 A B C D # D or unkey
```

### **Response:**

"<DTMF Digits Entered>"

## ***048: Recall a Message Slot 00..33***

This command allows the recalling of pre-programmed voice or cw messages. If the slot is empty you will get an error.

```
<048> xx
```

### **Parameters:**

XX is the message slot number. This number ranges from 01..33

### **Defaults:**

All message slots are empty

### **Error Codes:**

E1 - Invalid message slot

E2 - Message slot is empty

(System wide errors are listed in front of the manual)

### **Example 1:**

I want to check message slot 14 for its contents

```
048 14 D or unkey
```

### **Response:**

"Voice or CW data if the message is programmed otherwise Error 2"

### 049: Program a Message Slot

This command allows you to program the message slots with voice or cw messages. Slots 51..58 are special analog faceplate slots but can be used for small messages if not used in the analog application.

```
<049> xx y zzz..zzz
```

**Parameters:**

XX is the message slot number. This number ranges from 01..33

Message Slot	Length	Description
00	...	Software Version
01..25	20 words	User Message Slots
26..33	3 words	Analog Faceplate Slots

Y is the message type variable:

- 0 - CW Message
- 1 - Voice Message
- 2 - Impolite Large Digital Voice Recorder Message, Messages
- 3 - Polite Large Digital Voice Recorder Message, Messages
  - Cancels the message only
- 4 - Polite Large Digital Voice Recorder Message, Messages
  - Cancels the message and calls event 101 (See Command 064)

- ZZ are the CW characters from the Code Table (See Page 5-4) if message type 0
- ZZZ are the voice/small DVR words from the Word Table (See Appendix C) if message type 1
- ZZZ are the Large Digital Voice Recorder message slots if message type 2, 3 or 4

**Defaults:**

All message slots are empty

**Error Codes:**

- E1 - To much or to little data
- E2 - Invalid message type. Number must be between 0..2
- E3 - Invalid message slot

(System wide errors are listed in front of the manual)

**Example 1:**

I want to store the voice message in slot 01

"At <Male Time> You Are On The Repeater, <Good MAE>"

```
AT 077 <Time> 701 You 480 Are 047 On 310
The 421 Repeater 361 Pause 528 <Good MAF> 700
```

```
049 01 1 077 701 480 047 310 421 361 528 700 D or unkey
```

**Response:**

Response is what you typed in.



## ***111: Set Up the CW Speed***

This command allows the setting of the CW frequency speed. The speed is entered in words-per-minute. The speed can range from 01..35.

```
<111> xx
```

### **Parameters:**

XX is the CW speed. This number ranges from 01..35

### **Defaults:**

The CW speed defaults to 20 WPM

### **Notes:**

- The FCC states the CW speed must be 20 WPM or less

### **Error Codes:**

E1 - Invalid speed.

(System wide errors are listed in front of the manual)

### **Example 1:**

I want to slow my CW down to 13 WPM.

```
111 13 D or unkey
```

### **Response:**

"Code Speed At <Speed>"

## *112: Set Up the CW Tone Frequency*

This command sets up the CW's 2-tone frequencies. There are 2 tone frequencies available for CW tones. If the user wants a louder CW tone than normal courtesy beeps simply set both tones to the same CW frequency. This will give you a louder CW tone.

```
<112> xxxx yyyy
```

### **Parameters:**

XXXX is the tone counts for frequency 1 (See Appendix B)

YYYY is the tone counts for frequency 2 (See Appendix B)

### **Defaults:**

XXXX is 1064HZ

YYYY is 0000HZ

### **Error Codes:**

(System wide errors are listed in front of the manual)

### **Example 1:**

I want a louder CW tone. The tone needs to be 1064HZ. (0937 counts)

```
112 0937 0937 D or unkey
```

### **Response:**

"Code Frequency Is <Tone1> and <Tone2>"

## 113: Program a 2-Tone Pager Slot

This command programs the controllers 2-tone paging slots. These tones are standard tone pairs used with common pagers.

```
<113> ss bbaa ddc e rr
```

### Parameters:

SS is the pager slot. This number ranges from 01..19

AA is the column offset for the first tone (Refer to Tone group offset tables)

BB is the row offset for the first tone (Refer to Tone group offset tables)

CC is the column offset for the second tone (Refer to Tone group offset tables)

DD is the row offset for the second tone (Refer to Tone group offset tables)

E is the delay parameters for this tone sequence

**Tone Groups for Column and Row Offset**

Group->	TONE #	MOTO1	MOTO2	MOTO3	MOTO4	MOTO5	MOTO6	MOTOA
ROW	COL .->	01	02	03	04	05	06	07
00	0	330.5	569.1	1092.4	321.7	553.9	1122.5	358.9
01	1	349.0	600.9	288.5	339.6	584.8	1153.4	398.1
02	2	368.5	634.5	296.5	358.6	617.4	1185.2	441.6
03	3	389.0	669.9	304.7	378.6	651.9	1217.8	489.8
04	4	410.8	707.3	313.0	399.8	688.3	1251.4	543.3
05	5	433.7	746.8	953.7	422.1	726.8	1285.8	602.6
06	6	457.9	788.5	979.9	445.7	767.4	1321.1	668.3
07	7	483.5	832.5	1006.9	470.5	810.2	1357.6	741.3
08	8	510.5	879.0	1034.7	496.8	855.5	1395.0	822.2
09	9	539.0	928.1	1063.2	524.6	903.2	1433.4	912.0
10	A	569.1	979.9	569.1	569.1	979.9	979.9	979.9

**Tone Groups for Column and Row Offset cont...**

Group->	TONE #	MOTOB	MOTOZ	GE A'	GE B'	GE C'	MOTO10	MOTO11
ROW	COL . >	08	09	10	11	12	13	14
00	0	371.5	346.0	682.5	652.5	667.5	1472.9	1930.2
01	1	412.1	384.6	592.5	607.5	712.5	1513.5	1989.0
02	2	457.1	426.6	757.5	787.5	772.5	1555.2	2043.8
03	3	507.0	473.2	802.5	832.5	817.5	1598.0	2094.5
04	4	562.3	524.8	847.5	877.5	862.5	1642.0	2155.6
05	5	623.7	582.1	892.5	922.5	907.5	1687.2	2212.2
06	6	691.8	645.7	937.5	967.5	952.5	1733.7	2271.7
07	7	767.4	716.1	547.5	517.5	532.5	1781.5	2334.6
08	8	851.1	794.3	727.5	562.5	577.5	1830.5	2401.0
09	9	944.1	881.0	637.5	697.5	622.5	1881.0	2468.2
10	A	979.9	979.9	742.5	742.5	742.5	.....	.....

**E is the delay parameters for this tone sequence**

Sequence	1st Tone	Gap	2nd Tone	Pager Group
1	1.0 Sec	0.0 Sec	3.0 Sec	GE/MOT TN&VC
2	0.4 Sec	0.0 Sec	0.8 Sec	Moto Tone Only
3	1.0 Sec	0.0 Sec	3.0 Sec	NEC-B
4	1.0 Sec	0.25 Sec	3.0 Sec	NEC-A
5	1.0 Sec	0.0 Sec	1.0 Sec	NEC-C
6	0.4 Sec	0.0 Sec	0.8 Sec	NEC-M
7	0.5 Sec	0.0 Sec	0.5 Sec	NEC-L
8	0.4 Sec	0.0 Sec	0.4 Sec	NEC-D

**RR is the audio routing variable**

DTMF Allowed Execution of the Command	Number that corresponds to the device
Port 1	+1
Port 2	+2
Port 3	+4
Autopatch	+8
Control Receiver	+16

(RR) Audio routing variable = (port1)+(port2)+(port3)+(autopatch)+(control rx)

**Defaults:**

All slots are off or undefined

**Error Codes:**

E1 - Number input is to large

E2 - Number input is to small

E3 - Invalid pager slot. Number must be between 01..19

(System wide errors are listed in front of the manual)

**Example 1:**

I need to store a tone sequence slot 01, row 08, col. 01, row 10, col. 05, delay 1, route port 1

113 01 08 01 10 05 1 01 D or unkey

**Response:**

"Select <slot number> Programming"

## ***114: Recall the 2-Tone Paging Slot 01..20***

This command recalls the 2-tone slots programmed in Command 113.

```
<114> ss
```

### **Parameters:**

SS is the pager slot. This number ranges from 01..19

### **Defaults:**

All pager slots are disabled or unto defined

### **Error Codes:**

E1 - Invalid pager slot. Number must be between 01..19

(System wide errors are listed in front of the manual)

### **Example 1:**

I stored a tone sequence slot 01, row 08, col. 01, row 10, col. 05, delay 1, route port 1

```
114 01 D or unkey
```

### **Response:**

"Tone sequence sent"

## ***118: Program a Voice Message Delay for the Link Ports***

This command allows a delay using the voice word 'pause' to be inserted on voice messages sent out link ports. This is useful when long link systems request voice messages from the controller. The delay allows the receiver and transmitters to all become active before the voice response begins. If the voice delay is set to zero cancels both the repeater ports delay and the link ports delay.

```
<118> dd
```

### **Parameters:**

DD is the voice message delay. This number ranges from 00..29

### **Defaults:**

Delay set to 05 (2 second delay)

### **Error Codes:**

E1 - Number too large. Number must be between 00..29

(System wide errors are listed in front of the manual)

### **Example 1:**

I want to cancel the delay present on voice message.

```
118 00 D or unkey
```

### **Response:**

"Number Entered"

## *Chapter 5 Examples*



## ***Example 5-1: Generating a Custom Courtesy Beep***

A courtesy beep on the controller is an event that is requested after certain timers have expired. Once these timers have expired the controller fetches the courtesy beep event for the port that requested it. A courtesy beep event does not always have to be a tone sequence. The event can be anything from a command executed to a digital voice recorded message. Most users simply will use either the pre-programmed beep sequences (See Command 042). If one of the pre-programmed beeps does not meet your needs, then you can develop your own sequence. This involves calling a macro command from the event table.

The event table contains the events that are assigned to the courtesy beeps. Events 016..020 are the events for all 5 ports courtesy beeps.

Example: Develop a 3 beep sequence for Port 1's courtesy beep

1) Use Macro #01 for this example

2) Decide what each beep sequence will sound like

- Beep sequence 1: Tone 1:1000hz, 1200hz, 120mS long, 10mS delay
- Beep sequence 2: Tone 1:1200hz, 1400hz, 80mS long, 10mS delay
- Beep sequence 3: Tone 1:0600hz, 0800hz, 80mS long, 10mS delay

3) Look-up the frequency to counts conversion

- 1000hz = 0999, 1200hz = 0832
- 1200hz = 0832, 1400hz = 0713
- 0600hz = 1665, 0800hz = 1249

4) The format of Command 042

- 042 (tone count 1)(tone count 2)(length of tone 10mS)(length of delay 10mS)
- lengths: tone counts are 4 digits, lengths are 3 digits

5) Erase macro #01 using Command 165

- 165 01 D or unkey

6) Program macro #01 using Command 168

- 168 01 042 0999 0832 012 001 D or unkey ; Programs Beep sequence 1
- 168 01 042 0832 0713 008 001 D or unkey ; Programs Beep sequence 2
- 168 01 042 1665 1249 008 001 D or unkey ; Programs Beep sequence 3

7) Assign courtesy beep for port 1 (Event 016) to call macro #01 (Command 171)

- 064 016 2 171 37 D or unkey

This command assigns event (016) execute a command type (2) executes command number (171) and routes the response to all connected repeater ports. Once the event is programmed the controller enables execution of the sequence.

## *Example 5-2: Building Port 1's ID's*

The controllers ID's are similar to the above courtesy beep example. An ID sequence is again an event in the table of events. The ID events begin with the following events:

Event 001 - Port 1 Initial ID. This event is requested when the Initial ID timer has expired

The following pending ID's are cycled through 1,2,3..1,2,3. When the pending ID timer expires, and there is activity the controller fetches one of the 3 ID's.

Event 002 - Port 1 Pending ID #1

Event 003 - Port 1 Pending ID #2

Event 004 - Port 1 Pending ID #3

Event 005 - Port 1 Forced ID. This ID is sent when the ID wait timer expires and the controller is forced to send an ID for legal purposes.

Refer to Chapter 6 for system timers.

I want to have a voice Initial ID and CW pending ID's.

- Voice ID: Welcome to the K F 7 F W Repeater <Pause> Thank you for Identifying

- CW ID's: K F 7 F W / R

Voice ID will be message slot #01. CW ID will be message slot #02 (See Command 048,049)

1) Look-up to Voice words (See Appendix C)

- Welcome (468), To (002), The (421), K(040), F(035), 7(007), F(035), W(052), Repeater (361), Pause (528), Pause (528), Thank you (417), For (004), Identify (221), 'ing(489).

2) Look-up the CW words (See Command 043)

- K (20), F (15), 7 (07), F (15), W (32), / (36), R (27)

3) Program message slot #01 as a voice message (See Command 049)

- 049 01 1 468 002 421 040 035 007 035 052 361 528 528 417 004 221 489 D or unkey

4) Program message slot #02 as a CW message (See Command 049)

- 049 02 0 20 15 07 15 32 36 27 D or unkey

5) Assign the Initial ID event to call message slot #01

- 064 001 1 001 01 D or unkey

Where (001) is the event number, (1) is the event type, (001) is message slot 01, (01) routes the message only to port 1.

6) Assign the Pending ID events to call message slot #02

- 064 002 1 002 01 D or unkey ; Pending ID #1

- 064 003 1 002 01 D or unkey ; Pending ID #2

- 064 004 1 002 01 D or unkey ; Pending ID #3

- 064 005 1 002 01 D or unkey ; Forced ID

Your ID structure is now ready for Port 1. Follow the same rules for you other ports.

## ***Chapter 6 System Timers***

This command deals with the programming, recalling and re-starting of the several system timers

## 050: Recall a Timer Slot

This command allows the user to recall the contents of each timer slot.

<050> xx

### Parameters:

XX is the timer slot number

Timer #	Resolution	Default	Definition
00	10mS	200 (2 seconds)	Port 1 Hang Timer
01	10mS	200 (2 seconds)	Port 2 Hang Timer
02	10mS	200 (2 seconds)	Port 3 Hang Timer
03	10mS	200 (2 seconds)	Port 4 Hang Timer
04	10mS	200 (2 seconds)	Port 5 Hang Timer
05	10 Sec.	018 (3 Minute)	Port 1 Time-Out Timer
06	10 Sec.	018 (3 Minute)	Port 2 Time-Out Timer
07	10 Sec.	018 (3 Minute)	Port 3 Time-Out Timer
08	10 Sec.	018 (3 Minute)	Port 4 Time-Out Timer
09	10 Sec.	018 (3 Minute)	Port 5 Time-Out Timer
10	10 Sec.	060 (10 Minute)	Port 1 Initial ID Timer
11	10 Sec.	060 (10 Minute)	Port 2 Initial ID Timer
12	10 Sec.	060 (10 Minute)	Port 3 Initial ID Timer
13	10 Sec.	060 (10 Minute)	Port 4 Initial ID Timer
14	10 Sec.	060 (10 Minute)	Port 5 Initial ID Timer
15	10 Sec.	059 (9.90 Minute)	Port 1 Pending ID Timer
16	10 Sec.	059 (9.90 Minute)	Port 2 Pending ID Timer
17	10 Sec.	059 (9.90 Minute)	Port 3 Pending ID Timer
18	10 Sec.	059 (9.90 Minute)	Port 4 Pending ID Timer
19	10 Sec.	059 (9.90 Minute)	Port 5 Pending ID Timer

Timer #	Resolution	Default	Definition
20	10 Sec.	003 (30 Seconds)	Port 1 ID Wait Timer
21	10 Sec.	003 (30 Seconds)	Port 2 ID Wait Timer
22	10 Sec.	003 (30 Seconds)	Port 3 ID Wait Timer
23	10 Sec.	003 (30 Seconds)	Port 4 ID Wait Timer
24	10 Sec.	003 (30 Seconds)	Port 5 ID Wait Timer
25	10mS	100 (1 Second)	Port 1 Courtesy Beep Timer
26	10mS	100 (1 Second)	Port 2 Courtesy Beep Timer
27	10mS	100 (1 Second)	Port 3 Courtesy Beep Timer
28	10mS	100 (1 Second)	Port 4 Courtesy Beep Timer
29	10mS	100 (1 Second)	Port 5 Courtesy Beep Timer
30	10mS	100 (1 Second)	Port 1 Kerchunk Filter Timer
31	10mS	100 (1 Second)	Port 2 Kerchunk Filter Timer
32	10mS	100 (1 Second)	Port 3 Kerchunk Filter Timer
33	10mS	100 (1 Second)	Port 4 Kerchunk Filter Timer
34	10mS	100 (1 Second)	Port 5 Kerchunk Filter Timer
35	1 Sec.	300 (5 minutes)	User 1 Timer
36	1 Sec.	300 (5 minutes)	User 2 Timer
37	1 Sec.	300 (5 minutes)	User 3 Timer
38	1 Sec.	300 (5 minutes)	User 4 Timer
39	1 Sec.	300 (5 minutes)	User 5 Timer
40	10mS	010 (100mS)	DTMF Generate Length
41	10mS	010 (100mS)	DTMF Pause Length
42	10mS	500 (5 Seconds)	DTMF Scanner Timer
43	10mS	200 (2 Seconds)	DTMF Mute Timer
44	10 Sec.	030 (5 Minutes)	System Unlock Timer
45	10mS	100 (1 Second)	RBI-1 Send Timer
46	10mS	300 (3 Seconds)	Pre-Access Tone Length Timer

Timer #	Resolution	Default	Definition
47	10mS	800 (8 Seconds)	Pre-Access Timer
48	10mS	500 (5 Seconds)	Internal Autopatch Timer
49	10 Sec.	050 (8.33 Minutes)	Internal Autopatch Timer
50	10 Sec.	002 (20 Seconds)	Autopatch Log-on Timer
51	10 Sec.	006 (1 Minute)	Reverse Autopatch User Timer
52	10 Sec.	018 (3 Minute)	Reverse Autopatch Program Timer
53	10mS	100 (1 Second)	Over-the Air Ring Tone Length
54	10mS	040 (400mS)	Tone Delay Start Timer
55	10mS	400(4 Second)	Long Tone Zero Timer
56	10mS	050 (500mS)	CW Delay Start Timer
57	1 Sec.	010 (10 Sec.)	Public Mailbox Message Length
58	1 Sec.	004 (4 Sec.)	Public Mailbox Callsign Length
59	1 Sec.	030 (30 Sec.)	Private Mailbox Message Length
60	1 Sec.	010 (10 Sec.)	General Message Length
61	1 Sec.	060 (60 Sec.)	Maximum Message Length
62	10mS	200 (2 Sec.)	DTMF Timed Execution Timer

**Error Codes:**

E1 - Invalid timer number

(System wide errors are listed in front of the manual)

**Example 1:**

I need to check the value of the voice delay start timer.

050 55 D or unkey

**Response:**

Voice '&lt;Slot Number&gt;' is '&lt;Time in the slot&gt;'

## ***051: Start a Timer Slot***

This command re-starts a timer that is accessed from the timer table listed in Command 050.

```
<051> xx
```

### **Parameters:**

XX is the timer slot number listed in Command 050.

### **Defaults:**

Defaults are listed in Command 050.

### **Error Codes:**

E1 - Invalid timer slot

(System wide errors are listed in front of the manual)

### **Example 1:**

I just programmed the time-out timer on Port 1 to 3 minutes from 10 minutes. I need to restart it to take the new value.

```
051 05 D or unkey
```

### **Response:**

Voice '<Slot Number> is <Time in the slot>'

## ***052: Program a Timer Slot***

This command allows the programming of the system timer slots. Each timer slot can accept 3 digits of user input ranging from 000..999. Each timer has its own resolution which is listed in the timer table in Command 050.

```
<052> xx yyy
```

### **Parameters:**

XX is the timer slot number listed in Command 050.

YYY is the timer value that ranges from 000..999.

- Timer resolution is listed in Command 050.

### **Defaults:**

Defaults are listed in Command 050.

### **Error Codes:**

E1 - Invalid timer slot

(System wide errors are listed in front of the manual)

### **Notes:**

- After you program a timer slot the old value is still in the timer system. You need to re-start the timer using Command 051 in order for the new value to take place.

### **Example 1:**

I need to program the time-out timer on Port 1 to 3 minutes from 10 minutes.

```
052 05 018 D or unkey
```

### **Response:**

Voice '<Slot Number> is <Time in the slot>'



## ***066: Start a User Timer***

This command allows the user to start a user timer when an event occurs. This command is usually used in conjunction with the event tables. This user timer value is programmed using Command 050,051,052.

```
<066> x..x
```

### **Parameters:**

X..X are the user timers. These numbers must be between 1..5

- You can start several timers at once by entering all the timers in 1 sequence

### **Defaults:**

All timers are off

### **Notes:**

- Refer to the event table for user timer events to be executed when the timers expire

### **Error Codes:**

E1 - Invalid user timer slot

(System wide errors are listed in front of the manual)

### **Example 1:**

I want to start user timer 1,3,5.

```
066 1 3 5 D or unkey
```

### **Response:**

"Timer <Timer Number> Start"

## ***067: Stop a User Timer***

This command allows the user to stop a user timer when an event occurs. This command is usually used in conjunction with the event tables. This user timer value is programmed using Command 050,051,052.

```
<067> x..x
```

### **Parameters:**

X..X are the user timers. These numbers must be between 1..5

- You can stop several timers at once by entering all the timers in 1 sequence

### **Defaults:**

All timers are off

### **Notes:**

- Refer to the event table for user timer events to be executed when the timers expire

### **Error Codes:**

E1 - Invalid user timer slot

(System wide errors are listed in front of the manual)

### **Example 1:**

I want to stop user timer 2,4.

```
067 2 4 D or unkey
```

### **Response:**

"Timer <Timer Number> Stop"

## ***023: Control DTMF Timed Execution***

This command allows the user to enable or disable the DTMF timed execution function. When this function is enabled, the controller will automatically execute the entered DTMF digits. Each time a DTMF digit is entered the execution timer is restarted. This function is mainly used in conjunction with the reverse autopatch. When this function is disabled, only carrier drop or forced execution digit will execute commands.

```
<023> X
```

### **Parameters:**

X is the control variable

0 - disables timed execution

1 - enables timed execution

### **Defaults:**

Timed execution is disabled

### **Notes:**

- Refer to Command 050,051,052 for programming the execution timers length

### **Error Codes:**

E1 - Invalid mode requested. This number must range between 0..1

(System wide errors are listed in front of the manual)

### **Example 1:**

I want to enable DTMF timed execution

```
023 1 D or unkey
```

### **Response:**

"DTMF Execute <ON\OFF>"

*Examples for Chapter 6*

## ***Example 6-1: Using a User timer to Auto-Disconnect a Port***

It is a common request to have the controller auto-disconnect a port after activity on that port PTT is been inactive for a certain time period. We will use 2 macros, 1 user timer, and 4 events to make this task work. For the example I will use port 3 to be turned off after lack of activity.

1) Set-up user timer #1 for 5 minutes

- 052 35 300 D or unkey ; 300 \* 1 second = 5 minutes

2) Set-up User event #1 to call Macro #02

- 064 089 2 172 01 D or unkey ; User #1 event calls macro #01

Where (089) is the event number, (2) is the event type, (172) is the command name, (01) is where to route the response when executed.

3) Set-up Port 3's PTT just went active to reset timer with macro #03

- 064 052 2 173 01 D or unkey ; Port 3's PTT calls macro #03

Where (052) is the event number, (2) is the event type, (173) is the command name, (01) is where to route the response when executed.

4) Set-up Port 3's PTT just went inactive to reset timer with macro #03

- 064 088 2 173 01 D or unkey ; Port 3's PTT calls macro #03

Where (088) is the event number, (2) is the event type, (173) is the command name, (01) is where to route the response when executed.

5) Use Macro #01 as the Port 1-Port 3 On command

- 165 01 D or unkey ; Clear Macro 01's contents

- 168 01 000 1 3 D or unkey ; Connect port 1 to port 3

- 168 01 169 D or unkey ; Cancel all responses following this command

- 168 01 065 089 1 D or unkey ; Enable User Timer #1's Event

- 168 01 065 052 1 D or unkey ; Enable Port 3 on PTT reset User Timer

- 168 01 065 088 1 D or unkey ; Enable Port 3 on PTT reset User Timer

6) User Macro #02 as the Port1-Port 3 Off command

- 165 02 D or unkey ; Clear Macro 02's contents

- 168 02 002 1 3 D or unkey ; Disconnect port 1 from port 3

- 168 02 169 D or unkey ; Cancel all responses following this command

- 168 02 065 089 0 D or unkey ; Disable User Timer #1's Event

- 168 02 065 052 0 D or unkey ; Disable Port 3 on PTT reset User Timer

- 168 02 065 088 0 D or unkey ; Disable Port 3 on PTT reset User Timer

7) User Macro #03 to reset the user timer

- 165 03 D or unkey ; Clear Macro 03's contents

- 168 03 169 D or unkey ; Cancel all responses following this command

- 168 03 066 1 D or unkey ; Start User Timer #1

This example lets the PTT on the watched port call a command that resets the watch timer both when the PTT goes active and when the PTT goes inactive. This insures a correct 'lack of activity' time will be insured.

When the user enables the port 1-port 3 connection the macro does a variety of tasks.

- 1) Connects the 2 ports together
- 2) Enables the User timer event
- 3) Enables the PTT On event
- 4) Enables the PTT Off event

When the user disables the port 1-port 3 connection the macro does a variety of tasks.

- 1) Disconnects the 2 ports
- 2) Disables the User timer event
- 3) Disables the PTT On event
- 4) Disables the PTT Off event

The user would rename macro #01 to your Link ON codes, and rename macro #02 to your Link OFF codes. It may be nice to make the following changes to the on\off macros and add some customized message inside the macro so your users know what happened.

( These macros are the same as above with a minor change)

5) Use Macro #01 as the Port 1-Port 3 On command

- 165 01 D or unkey ; Clear Macro 01's contents
- \* - 168 01 048 04 D or unkey ; Recall Custom ON message
- 168 01 169 D or unkey ; Cancel all responses following this command
- \*\* - 168 01 000 1 3 D or unkey ; Connect port 1 to port 3
- 168 01 065 089 1 D or unkey ; Enable User Timer #1's Event
- 168 01 065 052 1 D or unkey ; Enable Port 3 on PTT reset User Timer
- 168 01 065 088 1 D or unkey ; Enable Port 3 on PTT reset User Timer

6) User Macro #02 as the Port1-Port 3 Off command

- 165 02 D or unkey ; Clear Macro 02's contents
- \* - 168 02 048 05 D or unkey ; Recall Custom OFF message
- 168 02 169 D or unkey ; Cancel all responses following this command
- \*\* - 168 02 002 1 3 D or unkey ; Disconnect port 1 from port 3
- 168 02 065 089 0 D or unkey ; Disable User Timer #1's Event
- 168 02 065 052 0 D or unkey ; Disable Port 3 on PTT reset User Timer
- 168 02 065 088 0 D or unkey ; Disable Port 3 on PTT reset User Timer

\* Added a message request

\*\* Moved the connect command until after the response suppress command

Build a Custom ON\OFF Message: Try these changes for your set-up

049 04 1 358 086 310 077 701 D or unkey ; Message: Remote Base On At <Time>

049 05 1 358 086 306 077 701 D or unkey ; Message: Remote Base OFF At <Time>

## ***Example 6-2: How to correctly set-up your ID timers***

In order for the controllers ID sequencer to work correctly, the user must set-up the ID timers correctly. The ID timers are designed to allow rotating ID's and initial ID's. The timers that are used to select and cycle through these timers are important to insure proper ID'ing with respect to the rules for system identification. Here are a few points to keep in mind when setting up your ID system

- 1) No more than 10 minutes can expire between an ID sequence
- 2) The initial ID is only sent when the initial ID timer has expired
- 3) The initial ID timer must be longer than the pending ID timer
- 4) The wait ID timer added to the pending ID timer must not be longer than the initial ID timer

Easy rule for setting up your timers

- Set your initial ID timer to 10 minutes (See Command 050-052)
- Set your pending ID timer to 9 minutes
- Set your wait ID timer to 30 seconds

After a long period of inactivity (Longer than the initial ID timer since the last ID), and a carrier is received on a repeater port, the controller will start 2 timers. Timer 1 is the pending ID timer and timer 2 is the ID wait timer. While the carrier is running, the controller (initial ID) knows an ID is needed. If the carrier does not unkey before the wait timer expires, the impolite ID will be sent. If the carrier drops before the wait timer expires, then the initial ID is sent. Once the ID's have been sent both the initial ID and the pending ID timers are re-started. When either of the timers expire the appropriate ID will be sent. If the pending ID timer expires first (Correct operation) and the receivers carrier is present the wait timer is started.

\* Note that the initial ID timer is still running even though the pending timer has expired.

If the wait timer expires while the carrier is still present, and the initial ID has not expired, then the pending ID is sent. If the initial ID timer has expired then the initial ID is sent.

Conclusion:

If you get sporadic initial ID's when you expect a pending ID, then make sure your timers are set-up as discussed above. A simple to help calculate your pending ID time is:

$$\begin{aligned}
 \text{Pending Time} &= (\text{Initial ID Timer}) - (\text{Wait Timer}) - (10 \text{ Seconds}) \\
 &= (10 \text{ Minutes}) - (30 \text{ Seconds}) - (10 \text{ Seconds}) \\
 &= 600 \text{ seconds} - 30 \text{ seconds} - 10 \text{ seconds} \\
 &= 560 \text{ seconds:} \quad \text{Maximum Pending ID time for correct ID sequence}
 \end{aligned}$$

## ***Chapter 7 Scheduler, Time-of Day Clock***

This chapter deals with the commands used in the event scheduler, time-of day clock, and the calendar functions.



## ***053: Speak Good Morning, Afternoon, or Evening***

This command simply speaks the part of the day it is. If the time is between 12:00AM and 11:59AM the female voice message is 'Good Morning'. If the time is between 12:00PM and 4:59PM the female voice message is 'Good Afternoon'. If the time is between 5:00PM and 11:59PM the female voice message is 'Good Evening'.

<053>

### **Parameters:**

There are no parameters for this command

### **Defaults:**

There are no defaults for this command

### **Notes:**

- Special voice word 700 speaks Good Morning, Afternoon, or Evening. To add these phrases to any voice message simply include word 700.

### **Error Codes:**

(System wide errors are listed in front of the manual)

### **Example 1:**

I want to know the part of the day it is

053 D or unkey

### **Response:**

Voice: 'Good <Morning><Afternoon><Evening>'

## ***054: Recall Time-of-Day Clock (Male)***

This command reads the time-of-day clock in male speech.

<054>

### **Parameters:**

There are no parameters for this command

### **Defaults:**

There are no defaults for this command

### **Notes:**

- Special voice word 701 speaks Male time-of-day. To add these phrases to any voice message simply include word 701.

### **Error Codes:**

(System wide errors are listed in front of the manual)

### **Example 1:**

I want to know the time-of-day

054 D or unkey

### **Response:**

Voice: '<Time>'

## ***055: Recall Time-of-Day Clock (Female)***

This command reads the time-of-day clock in female speech.

<055>

### **Parameters:**

There are no parameters for this command

### **Defaults:**

There are no defaults for this command

### **Notes:**

- Special voice word 702 speaks Female time-of-day. To add these phrases to any voice message simply include word 702.

### **Error Codes:**

(System wide errors are listed in front of the manual)

### **Example 1:**

I want to know the time-of-day

055 D or unkey

### **Response:**

Voice: 'The Time Is<Time>'

## ***056: Recall Date (Male)***

This command reads the date in male speech.

<056>

### **Parameters:**

There are no parameters for this command

### **Defaults:**

There are no defaults for this command

### **Notes:**

- Special voice word 703 speaks Male date. To add these phrases to any voice message simply include word 703.

### **Error Codes:**

(System wide errors are listed in front of the manual)

### **Example 1:**

I want to know what the date is.

056 D or unkey

### **Response:**

Voice: '<Day of the week> <Month> <Day> <Year>'

## ***057: Recall the Day (Male)***

This command reads the day in male speech.

<057>

### **Parameters:**

There are no parameters for this command

### **Defaults:**

There are no defaults for this command

### **Notes:**

- Special voice word 704 speaks Male day. To add these phrases to any voice message simply include word 704.

### **Error Codes:**

(System wide errors are listed in front of the manual)

### **Example 1:**

I want to know what day it is.

057 D or unkey

### **Response:**

Voice: '<Day>'

## 058: *Setting the Time*

This command sets the internal clocks time-of-day. Setting the time is in 12 hour format with an AM/PM digit.

```
<058> hh mm a/p
```

### Parameters:

HH are the hours that range from 01..12

MM are the minutes that range from 00..59

A/P indicate what part of the day it is

0 - AM

1 - PM

### Defaults:

There are no defaults for this command

### Error Codes:

E1 - Invalid hour setting. Number must be between 01..12

E2 - Invalid minute setting. Number must be between 00..59

E3 - Invalid AM/PM setting. Number must be between 0..1

(System wide errors are listed in front of the manual)

### Example 1:

I want to set the time to 3:35 PM

```
058 03 35 1 D or unkey
```

### Response:

Voice: 'Good <Morning,Afternoon,Evening> The Time Is <Time>'

## 059: Setting the Date

This command sets the internal clocks date function.

```
<059> mm dd yy z
```

### Parameters:

MM is the month indication that range from 01..12

DD is the day indication that ranges from 01..31

YY is the year indication that ranges from 00..99

Z is the day of the week

Number	Day of the Week
1	Sunday
2	Monday
3	Tuesday
4	Wednesday
5	Thursday
6	Friday
7	Saturday

### Defaults:

There are no defaults for this command

### Error Codes:

E1 - Invalid month setting. Number must be between 01..12

E2 - Invalid day setting. Number must be between 00..31

E3 - Invalid year setting. Number must be between 00..99

E4 - Invalid day of the week setting. Number must be between 1..7

(System wide errors are listed in front of the manual)

### Example 1:

I want to set the date to November 28, 1995 Tuesday

```
059 11 28 95 3
```

### Response:

"<Month> <Day> <Year> <Day of the week>"

## ***060: Scheduler Event Recall***

This command recalls a scheduler slot. There are 20 slots that can be programmed from hourly to yearly events. The commands that are executed with the scheduler are located in the event table (See Command 063,064,065).

```
<060> xx
```

### **Parameters:**

XX is the scheduler slot that ranges from 01..20.

### **Defaults:**

All scheduler slots are off

### **Error Codes:**

E1 - Invalid scheduler slot

(System wide errors are listed in front of the manual)

### **Example 1:**

I want to see what if anything is in scheduler slot 05

```
060 05 D or unkey
```

### **Response:**

"<ON/OFF>" or

"Scheduler contents (See Command 061 for definitions)"



## ***061: Scheduler Event Program***

This command programs the scheduler events. Pay special attention to the format of the hourly information.

- **Hourly Event**

```
<061> ss mm
```

**Parameters:**

SS is the scheduler slot that ranges from 01..20.

MM is the minute that an event is requested. This number ranges from 01..59

- **Daily Event**

```
<061> ss hh a/p mm
```

**Parameters:**

SS is the scheduler slot that ranges from 01..20.

HH is the hour that an event is requested. This number ranges from 01..12

A/P is the hour AM/PM the that an event is requested. This number ranges from 0..1

0 - AM

1 - PM

MM is the minute that an event is requested. This number ranges from 00..59

- Weekly Event**

```
<061> ss dd hh a/p mm
```

**Parameters:**

SS is the scheduler slot that ranges from 01..20.

DD is the day of that an event is requested. This number ranges from 01..07

Z is the day of the week

Number	Day of the Week
01	Sunday
02	Monday
03	Tuesday
04	Wednesday
05	Thursday
06	Friday
07	Saturday

HH is the hour that an event is requested. This number ranges from 01..12

A/P is the hour AM/PM that an event is requested. This number ranges from 0..1

0 - AM

1 - PM

MM is the minute that an event is requested. This number ranges from 00..59

- Monthly Event**

```
<061> ss nn dd hh a/p mm
```

**Parameters:**

SS is the scheduler slot that ranges from 01..20.

NN is the month that an event is requested. This number ranges from 01..12

DD is the day that an event is requested. This number ranges from 01..31

HH is the hour that an event is requested. This number ranges from 01..12

A/P is the hour AM/PM the that an event is requested. This number ranges from 0..1

0 - AM

1 - PM

MM is the minute that an event is requested. This number ranges from 00..59

- **Yearly Event**

<061> *ss yy nn dd hh a/p mm*

**Parameters:**

SS is the scheduler slot that ranges from 01..20.

YY is the year that an event is requested. This number ranges from 00..99

NN is the month that an event is requested. This number ranges from 01..12

DD is the day that an event is requested. This number ranges from 01..31

HH is the hour that an event is requested. This number ranges from 01..12

A/P is the hour AM/PM the that an event is requested. This number ranges from 0..1

0 - AM

1 - PM

MM is the minute that an event is requested. This number ranges from 00..59

**Defaults:**

All scheduler slots are off

**Error Codes:**

E1 - Invalid scheduler slot

E2 - Error in converting one of the entry segments (Year,Month,Day etc...)

(System wide errors are listed in front of the manual)

**Voice Response:**

Hourly: <ON> <Minute>

Daily:<ON> <Hour> <AM/PM> <Minute>

Weekly:<ON> <Day> <Hour> <AM/PM> <Minute>

Monthly:<ON> <Month><Day> <Hour> <AM/PM> <Minute>

Yearly:<ON> <Year><Month><Day> <Hour> <AM/PM> <Minute>

## ***062: Scheduler Event Enable/Disable***

This command allows the enable/disable control of a scheduler event.

```
<062> xx y
```

### **Parameters:**

XX is the scheduler slot that ranges from 01..20.

Y is the control variable

1 - Enable the scheduler event

0 - Disables the scheduler event

### **Defaults:**

All scheduler slots are off

### **Error Codes:**

E1 - Invalid scheduler slot

(System wide errors are listed in front of the manual)

### **Example 1:**

I want to disable scheduler slot #14

```
062 14 0 D or unkey
```

### **Response:**

```
"<Scheduler slot> <ON/OFF>"
```

## *Examples for Chapter 7*

## ***Example 7-1: Set-up the Scheduler to reset my Analog High/Low Readings at 12:00AM***

I need the controller to reset the outside temperature sensor high/low readings at 12:00AM so the true high/low the users requests is accurate for that day. The temperature uses analog input 1.

1) Choose a daily event for the calling of a macro.

- 061 01 12 0 00 D or unkey ; Programs event 01 for 12:00AM

Where (01) is the scheduler slot, (12) is the hour of the event, (0) indicates AM, (00) is the minutes when the event occurs. When this event expires, it will request an event. We will have that event call the macro to reset the high/lows.

2) Program Scheduler event 01 to call macro 05.

- 064 030 2 175 01 D or unkey ; Programs event to execute a command

Where (030) is scheduler event 01, (2) is the event type that calls a command, (175) is the command to be executed: macro 05, (01) is where to route to response from the macro.

3) Program macro 05 to clear analog 1's high/low

- 165 05 D or unkey ; Clears macro 05

- 168 05 045 316 390 414 111 D or unkey ; Speaks 'Out Side Temperature Clear'

- 168 05 169 D or unkey ; Cancels responses

- 168 05 074 1 D or unkey ; Reset Analog 1 high/low values

4) The outside temperature high/lows are now cleared at 12:00 AM daily. When the scheduler expires it calls macro 05 which clears the analog high/low data.

## ***Example 7-2: Set-up the Scheduler to Enable Time readings on the hour beginning at 8:00 AM until 6:00 PM***

The scheduler can be used to enable/disable other scheduler events. In this example you are employing 3 scheduler events.

- 1) Scheduler event 1 is a daily event that enables the time being spoken hourly event
- 2) Scheduler event 2 is an hourly event that enables the time spoken
- 3) Scheduler event 3 is a daily event that disabled the time being spoken hourly event

This may seem a difficult task, but it walk through the steps and see how easy it really is.

### 1) Set-up the scheduler events

- 061 02 08 0 00 D or unkey ; Scheduler 02 is a daily event at 8:00AM
- 061 03 06 1 00 D or unkey ; Scheduler 03 is a dialy event at 6:00 PM
- 061 04 00 D or unkey ; Scheduler 04 is an hourly event on the hour

### 2) Set-up the event tables calling of macros 06 and 07

- Macro 06 will enable the hourly event and Macro 07 will disable the hourly event.

- 165 06 D or unkey ; Clear macro 06
- 168 06 169 D or unkey ; Cancels responses
- 168 06 065 033 1 D or unkey ; Enables the hourly event

- Macro 07 will disable the hourly event.

- 165 07 D or unkey ; Clear macro 07
- 168 07 169 D or unkey ; Cancels responses
- 168 07 065 033 0 D or unkey ; Disables the hourly event

### 3) Set-up the scheduler events

- 064 031 2 176 01 D or unkey ; Event 031 calls command 176, macro 06
- 064 032 2 177 01 D or unkey ; Event 032 calls command 177, macro 07
- \* - 064 033 2 055 01 D or unkey ; Event 033 calls command 055, speak the time

Once these events begin to run the controller will speak the female time at the top of the hour.

To make the time be spoken politely (If there is activity when the voice begins, the voice is canceled) have scheduler slot 03 call a message slot that speaks the time with the polite word as part of the message.

1) Change '\*' to read: 064 033 1 005 01 D or unkey ; Request message slot 05

2) Program your time reading as a message

- 049 05 1 702 733 D or unkey ; speak the time politely

The time is now polite when called from a message slot.

## ***Chapter 8: Event Tables***

This command deals with the system event tables. These tables control command fetching for most system events.



## ***063: Recall an Event***

This command allows the user to recall an event entry. These events are the most important function of the RLC-2 controller. With the events most functions of the controller can be controlled, handled, or spoken.

```
<063> xxx
```

### **Parameters:**

XXX is the event table slot. This number ranges from 000..108

### **Defaults:**

All event are off

### **Error Codes:**

E1 - Invalid event slot

(System wide errors are listed in front of the manual)

### **Example 1:**

I want to see if my courtesy beep event is enabled for Port 1

```
063 016 D or unkey
```

### **Response:**

"<Slot Number> is <Message Type>, <Slot Number> is <ON/OFF>, Route is <Audio Routing Variable>"

## 064: Program an Event

This command program an event table entry. These events are the most important function of the RLC-2 controller. With the events most functions of the controller can be controlled, handled, or spoken.

```
<064> sss t xxx rr
```

### Parameters:

**SSS is the event table slot. This number ranges from 000..108**

Slot Number	Description
000	Controller Reset just occurred
001	Port 1 Initial ID
002	Port 1 Rotating ID 1
003	Port 1 Rotating ID 2
004	Port 1 Rotating ID 3
005	Port 1 Forced ID
006	Port 2 Initial ID
007	Port 2 Rotating ID 1
008	Port 2 Rotating ID 2
009	Port 2 Rotating ID 3
010	Port 2 Forced ID
011	Port 3 Initial ID
012	Port 3 Rotating ID 1
013	Port 3 Rotating ID 2
014	Port 3 Rotating ID 3
015	Port 3 Forced ID
016	Port 1 Courtesy Beep Requested
017	Port 2 Courtesy Beep Requested
018	Port 3 Courtesy Beep Requested
019	Port 4 Courtesy Beep Requested (Autopatch)
020	Port 5 Courtesy Beep Requested (Control Receiver)

Slot Number	Description
-------------	-------------

021	Port 1 Drop-out Message 1
022	Port 1 Drop-out Message 2
023	Port 2 Drop-out Message 1
024	Port 2 Drop-out Message 2
025	Port 3 Drop-out Message 1
026	Port 3 Drop-out Message 2
027	Port 1 Time-Out Message
028	Port 2 Time-Out Message
029	Port 3 Time-Out Message
030	Scheduler Event 01
031	Scheduler Event 02
032	Scheduler Event 03
033	Scheduler Event 04
034	Scheduler Event 05
035	Scheduler Event 06
036	Scheduler Event 07
037	Scheduler Event 08
038	Scheduler Event 09
039	Scheduler Event 10
040	Scheduler Event 11
041	Scheduler Event 12
042	Scheduler Event 13
043	Scheduler Event 14
044	Scheduler Event 15 or Pre-Access Port 1 just went active
045	Scheduler Event 16 or Pre-Access Port 2 just went active
046	Scheduler Event 17 or Pre-Access Port 3 just went active
047	Scheduler Event 18 or Pre-Access Port 1 just went inactive
Slot Number	Description

048	Scheduler Event 19 or Pre-Access Port 2 just went inactive
049	Scheduler Event 20 or Pre-Access Port 3 just went inactive
050	Port 1 PTT Just Went Active
051	Port 2 PTT Just Went Active
052	Port 3 PTT Just Went Active
053	LTZ (Long Tone Zero) Event requested
054	Port 1 Receiver just went Active
055	Port 2 Receiver just went Active
056	Port 3 Receiver just went Active
057	Port 4 Receiver just went Active
058	Port 5 Receiver just went Active
059	Port 1 Receiver just went Inactive
060	Port 2 Receiver just went Inactive
061	Port 3 Receiver just went Inactive
062	Port 4 Receiver just went Inactive
063	Port 5 Receiver just went Inactive
064	Analog 1 just went into High Alarm
065	Analog 2 just went into High Alarm
066	Analog 3 just went into High Alarm
067	Analog 4 just went into High Alarm
068	Analog 1 just went into Low Alarm
069	Analog 2 just went into Low Alarm
070	Analog 3 just went into Low Alarm
071	Analog 4 just went into Low Alarm
072	Analog 1 just came out of Alarm
073	Analog 2 just came out of Alarm
074	Analog 3 just came out of Alarm
Slot Number	Description

075	Analog 4 just came out of Alarm
076	Input 1 just went Low
077	Input 2 just went Low
078	Input 3 just went Low
079	Input 4 just went Low
080	Input 1 just went High
081	Input 2 just went High
082	Input 3 just went High
083	Input 4 just went High
084	DTMF Decoder just went Active
085	DTMF Decoder just went Inactive
086	Port 1 PTT just went Inactive
087	Port 2 PTT just went Inactive
088	Port 3 PTT just went Inactive
089	User Timer 1 just Expired
090	User Timer 2 just Expired
091	User Timer 3 just Expired
092	User Timer 4 just Expired
093	User Timer 5 just Expired
094	Autopatch just went Active before Dialing
095	Autopatch just Started Dialing
096	Autopatch just went On-Hook (Hung-up)
097	Manual Autopatch just went Active
098	Reverse Autopatch just Answered
099	Reverse Autopatch is just about to Hang-up
100	Port 1 voice message was interrupted (See Command 045)
101	DVR Message was just interrupted (See Command 045)
Slot Number	Description

102	Autopatch Time-out Message
103	Control Receiver Message
104	Autopatch Memory Dial Message
105	AutoPatch Direct Dial Message
106	Port 2 voice message was interrupted (See Command 045)
107	Port 3 voice message was interrupted (See Command 045)
108	Reverse Autopatch Call Sign Request (See Command 119)

**T is the event type**

Event Number	Event Type
0	No Event, Same as Disabling the Event
1	Request a message from the Message Slot Storage (Command 048 and 049)
2	Request a Command be executed. Commands can not contain any additional data
3	Request a Pre-Programmed Courtesy Beep Slot (Command 042)
4	Request an internal, pre-programmed message

**XXX is the message number**

If your event type (T) is 1	XXX = Message Slot Number Slot 01 = 001
If your event type (T) is 2	XXX = Command Number to be Executed Command 055 = 055
If your event type (T) is 3	XXX = Pre-Programmed Courtesy Beep Beep 04 = 004 (See Command 042)
If your event type (T) is 4	XXX = Pre-Programmed internal message Message 03 = 003 (See Below)

**RR is the audio routing variable**

DTMF Allowed Execution of the Command	Number that corresponds to the device
Port 1	+1
Port 2	+2
Port 3	+4
Autopatch	+8
Control Receiver	+16

(RR) Audio routing variable = (port1)+(port2)+(port3)+(autopatch)+(control rx)

**Special routing variables are provided to allow routing of messages to connected ports.**

Audio Routing Number	Definition
32	Route responses to all ports connected to Port 1
33	Route responses to all ports connected to Port 2
34	Route responses to all ports connected to Port 3
35	Route responses to all ports connected to Port 4
36	Route responses to all ports connected to Port 5
37	Route responses to all ports that are repeaters connected to Port 1
38	Route responses to all ports that are repeaters connected to Port 2
39	Route responses to all ports that are repeaters connected to Port 3
40	Route responses to all ports that are repeaters connected to Port 4
41	Route responses to all ports that are repeaters connected to Port 5
42	Route responses to all ports that are connected to the port that is controlling with DTMF, including the DTMF'ing port
43	Route responses to all ports that are repeaters connected to the port that is controlling with DTMF, including the DTMF'ing port

**Defaults:**

Event #	Message Definition
000	Reset Message: Defaults to Internal Message 00
001	Port 1, Initial ID: Defaults to Internal Message 06
002	Port 1, Rotating ID 1: Defaults to Internal Message 07
003	Port 1, Rotating ID 2: Defaults to Internal Message 08
004	Port 1, Rotating ID 3: Defaults to Internal Message 09
005	Port 1, Forced ID: Defaults to Internal Message 10
016	Port 1 Courtesy Beep: Defaults to Preset beep 06
017	Port 2 Courtesy Beep: Defaults to Preset beep 07
018	Port 3 Courtesy Beep: Defaults to Preset beep 08
027	Port 1 Time-Out Message: Defaults to Internal Message 02
096	Autopatch Hang-up Message: Defaults to Internal Message 04
098	Reverse Autopatch Just Answered: Defaults to Internal Message 05
104	Autopatch Memory Dial Message: Defaults to Internal Message 11
105	Autopatch Direct Dial Message: Defaults to Internal Message 12



**Internal Messages:**

Message #	Message Contents:
00	Controller Ready
01	Autopatch
02	Repeater Time-Out
03	Link Time-Out
04	Autopatch Off At <Male Time>, Good <Morning, Afternoon, Evening>
05	Welcome To The Repeater, Please Enter Code Immediately
06	Welcome To The Repeater Identify 1
07	Welcome To The Repeater Identify 2
08	Welcome To The Repeater Intentify 3
09	Welcome To The Repeater Intentify 4
10	Welcome To The Repeater Intentify 5
11	Auto Dial
12	Auto Patch
13	The Door is Open
14	The Door is Closed

**Error Codes:**

E1 - Invalid event slot number. Number must range from 000..107

E2 - Invalid event type. Number must range from 0..4

(System wide errors are listed in front of the manual)

Example:

I need to assign a pre-programmed courtesy beep to port 1

064 016 3 006 01 D or unkey

**Response:**

"<Slot Number> is <Message Type>, <Slot Number> is <ON/OFF>, Route is <Audio Routing Variable>"

## ***065: Enable/Disable an Event***

This command enables and disables an event slot. This does the same as setting the event to a '0' type, but does not require the complete re-programming of that event. Therefore other events can enable/disable events without affecting their contents.

```
<065> xxx y
```

### **Parameters:**

XXX is the event table slot. This number ranges from 000..108

Y is the control variable

1 - Enables the event

0 - Disables the event

### **Defaults:**

All event are off

### **Error Codes:**

E1 - Invalid event slot

(System wide errors are listed in front of the manual)

### **Example 1:**

I want to disable Port 1's courtesy beep.

```
065 016 0 D or unkey
```

### **Response:**

"<Event Number> is <ON/OFF>"

*Examples for Chapter 8*

## ***Example 8-1: How to have a Voice ID revert to a CW ID***

A commonly asked question is how to cause a Voice ID to change to a CW ID when interrupted. This term is called a polite voice ID. There are 3 steps in making an ID polite.

- 1) Include the voice special word '734' in the voice message
- 2) Program a CW ID slot
- 3) Assign event 100 (If for port 1) to call your CW ID

### Step #1

Store my Initial ID into slot #01 'Welcome to the K F 7 F W Repeater <Pause> Good M/A/E'

- 049 01 1 468 002 421 040 035 007 035 052 361 528 700 **734** D or unkey or <Enter>

\*\* Note the '734' at the end of the sequence indicates a polite ID that calls an event when interrupted.

### Step #2

Program a CW ID into slot #05 'K F 7 F W / R '

- 049 05 0 20 15 07 15 22 36 27 D or unkey or <Enter>

### Step #3

Assign event 100 (Port 1 voice interrupted event) to call message slot 005

- 064 100 1 005 01 D or unkey or <Enter>

Now to test what you just programmed recall message 01 using Command 048 01 <unkey>, when you key-up in the middle of the message it will switch over to CW.

## ***Chapter 9: Analog Input System***

This chapter deals with the analog I/O system, commands, conversions and calibrations.

## 070: Analog Line Faceplate Assignment

This command allows the assignment of an analog conversion faceplate to any of the analog input lines. These conversion faceplates take the analog input voltage and convert it to a number that corresponds to the analog inputs voltage. This command only converts the input, Command 072 will handle the actual calibration of the converted number.

<070> x yy

### Parameters:

X is the analog input to assign the faceplate. This number ranges from 1..4

**YY is the requested analog conversion faceplate**

Faceplate #	Switch On	Switch Off	Conversion from volts to words
00	0.00-25.00 Volts	0.00-5.00 Volts	0<point>00 - 5<point>00
01	0.0-25.0 Volts	0.00-5.00 Volts	00<point>0 - 16<point>0
02	0.00-25.00 Volts	0.00-5.00 Volts	00<point>0 - 32<point>0
03	0.00-25.00 Volts	0.00-5.00 Volts	00<point>0 - 64<point>0
04	0.00-25.00 Volts	0.00-5.00 Volts	00<point>0 - 128<point>0
05	0.00-25.00 Volts	0.00-5.00 Volts	000 - 255
06	-----	Kelvin Temperature	Low Resolution Fahrenheit
07	-----	Kelvin Temperature	Low Resolution Celsius
08	-----	Special Circuit °F	High Resolution Fahrenheit
09	-----	Special Circuit °C	High Resolution Celsius
10	0.00-25.00 Volts	0.00-5.00 Volts	000 - 100 (Percent)
11	0.00-25.00 Volts	0.00-5.00 Volts	000 - 360 (Wind direction)
12	0.00-25.00 Volts	0.00-5.00 Volts	00<point>0 - 25<point>0
13	0.00-25.00 Volts	0.00-5.00 Volts	Special Faceplate (See Below)
14	0.00-25.00 Volts	0.00-5.00 Volts	S0..S9<plus>60 (Signal Level)
15	-----	Wind Speed Input	Calm .. 100MPH Wind Speed

**Special Faceplate:**

This faceplate is provided to allow custom responses for input voltages. Applications for this faceplate is special wind directions, 8-quadrant conversion results etc...

Analog Input Value	Special Message Slot	Analog Input Value	Special Message Slot
$V_{input} \div 8$	51	$V_{input} \div 4$	55
$V_{input} \div 7$	52	$V_{input} \div 3$	56
$V_{input} \div 6$	53	$V_{input} \div 2$	57
$V_{input} \div 5$	54	$V_{input} \div 1$	58

**Voltage input limitations:**

In order for the RLC-2 to allow higher than 5.00 volts input, on-board voltage dividers are provided on all controllers. When higher input voltages are used, the (Resistor in Rev. A, Jumper in Rev. B, or the Switch in Rev. C) must be in line. When voltages below 5.00 volts are used (like temperature sensors), the (Resistor in Rev. A, Jumper in Rev. B, or the Switch in Rev. C) must be out of line or off. When a temperature sensor is used, an external +12 volt power supply (With a 10K series resistor between the sensor and +12v) is needed. On Revision C boards, the power switch simply needs to be on.

**Resistor Definition, Revision A**

Resistor Number	Clip the Resistor Function
R3	Voltage Divider, Analog 1
R4	Voltage Divider, Analog 2
R5	Voltage Divider, Analog 3
R6	Voltage Divider, Analog 4

**Jumper Definition, Revision B**

Jumper Number	Jumper Function
J13	Voltage Divider, Analog 1
J14	Voltage Divider, Analog 2
J15	Voltage Divider, Analog 3
J16	Voltage Divider, Analog 4

**Switch Definition Revision C**

Switch Number	Switch Function
1	Voltage Divider, Analog 1
2	Voltage Divider, Analog 2
3	Voltage Divider, Analog 3
4	Voltage Divider, Analog 4
5	Temperature power, Analog 1
6	Temperature power, Analog 2
7	Temperature power, Analog 3
8	Temperature power, Analog 4

**Defaults:**

All faceplates set to 00

**Notes:**

- Check your board before connecting any voltage input.

**Error Codes:**

E1 - Invalid analog input line. Number must be between 1..4

E2 - Invalid analog faceplate. Number must be between 00..15

(System wide errors are listed in front of the manual)

**Example 1:**

I need to monitor my 12 battery voltage on analog #2

(Assume the analog input is set-up to handle the voltage)

070 2 01 D or unkey

**Response:**

"<Analog Line> is <Faceplate>"



## ***071: Recall Analog Faceplate***

This command allows the user to recall what conversion faceplate is assigned to a specific analog input line. If a conversion result is not converting as expected, then first check the conversion faceplate to make sure it is correct.

```
<071> x
```

### **Parameters:**

X is the analog input to assign the faceplate. This number ranges from 1..4

### **Defaults:**

All faceplates set to 00

### **Error Codes:**

E1 - Invalid analog input line. Number must be between 1..4

(System wide errors are listed in front of the manual)

### **Example 1:**

I am getting a wrong analog readback from analog 4. I need to check the faceplate.

```
071 4 D or unkey
```

### **Response:**

"Analog Line> is <Faceplate>"

## ***072: Analog Line Calibration***

This command allows the user to calibrate an analog input. This feature is required to make an input translate the input voltage to a voice number correctly.

To determine if an input needs to be calibrated:

- 1) Assign the appropriate conversion face
- 2) Read the analog input using Command 075

If the number read differs from the number at the analog input, you need to calibrate

```
<072> x y zz
```

### **Parameters:**

X is the analog input line. This number is between 1..4

Y is control variable

1 - Add the offset

0 - Subtract the offset

ZZ is the calibration number. This number is between 00..99

### **Defaults:**

All analog calibration is plus 00

### **Notes:**

- If you can not calibrate an input, check your switch settings and faceplates

### **Error Codes:**

E1 - Invalid analog line. This number must be between 1..4

(System wide errors are listed in front of the manual)

### **Example 1:**

My temperature sensor on analog input 2 reads high. I need to calibrate is down

```
072 2 0 03 D or unkey
```

### **Response:**

"<Analog Line> is <Calibration Number>"

## ***073: Recall Analog Line Calibration***

This command allows the user to recall the calibration variables. These variables are explained in Command 072

`<073> x`

### **Parameters:**

X is the analog input line. This number is between 1..4

### **Defaults:**

All analog calibration is plus 00

### **Error Codes:**

E1 - Invalid analog line. This number must be between 1..4  
(System wide errors are listed in front of the manual)

### **Example 1:**

I want to check the calibration value for analog input 4

`073 4 D or unkey`

### **Response:**

"<Analog Line> is <Calibration Value>"

## ***074: Reset Analog 1-4 High/Low Values***

This command allows the user to reset the analog input high-low variations to the current reading. This feature must be used when monitoring the maximum-minimum extremes that your analog inputs take. Once a high level is reached, any lower readings will not be stored for the high reading. The same procedure is true for the lower extremes. This command also resets the high/low times and the high/low dates.

```
<074> x
```

### **Parameters:**

X is an analog input. This number must be between 1..4

### **Defaults:**

Analog high/lows are cleared on reset

### **Error Codes:**

E1 - Invalid analog line. This number must be between 1..4  
(System wide errors are listed in front of the manual)

### **Example 1:**

I want to reset my temperature sensors on analog 1,2.

```
074 1 2 D or unkey
```

### **Response:**

"<Analog Line> is 0"

## ***075: Read an Analog Line***

This command allows the user to read selected analog inputs. The user would normally not use this command for day-to-day operation. Because of the analog reading special words (Words 705..708), the user would normally include these words for message readback. This command is mainly used for setting up the analog system.

`<075> x`

### **Parameters:**

X is the analog input. This number must be between 1..4

### **Defaults:**

There are no defaults for this command

### **Error Codes:**

E1 - Invalid analog line. This number must be between 1..4  
(System wide errors are listed in front of the manual)

### **Example 1:**

I want to read analog 3 input line

`075 3 D or unkey`

### **Response:**

"<Analog Line>"

## ***076: Read an Analog High Value***

This command allow the user to recall the analog high extreme readings. The user would normally not use this command for day-to-day operation. Because of the analog high reading special words (Words 709..712), the user would normally include these words for message readback. This command is mainly used for setting up the analog system.

```
<076> x
```

### **Parameters:**

X is the analog inputs. This number must be between 1..4

### **Defaults:**

Analog high/lows are cleared on reset

### **Error Codes:**

E1 - Invalid analog line. This number must be between 1..4  
(System wide errors are listed in front of the manual)

### **Example 1:**

I want to check analog 1 high value

```
076 1 D or unkey
```

### **Response:**

"<Analog High Value>"

## ***077: Read an Analog Low Value***

This command allow the user to recall the analog low extreme readings. The user would normally not use this command for day-to-day operation. Because of the analog low reading special words (Words 713..716), the user would normally include these words for message readback. This command is mainly used for setting up the analog system.

<077> x

### **Parameters:**

X is the analog inputs. This number must be between 1..4

### **Defaults:**

Analog high/lows are cleared on reset

### **Error Codes:**

E1 - Invalid analog line. This number must be between 1..4  
(System wide errors are listed in front of the manual)

### **Example 1:**

I want to check analog 4 low value

077 4 D or unkey

### **Response:**

"<Analog High Value>"

# 078: Read an Analog High Line Time

This command allow the user to recall the time an analog high extreme occurred. The user would normally not use this command for day-to-day operation. Because of the analog high time special words (Words 717..720), the user would normally include these words for message readback. This command is mainly used for setting up the analog system.

```
<078> x
```

**Parameters:**

X is the analog inputs. This number must be between 1..4

**Defaults:**

Analog high/low are cleared on reset

**Error Codes:**

E1 - Invalid analog line. This number must be between 1..4  
(System wide errors are listed in front of the manual)

**Example 1:**

I want to check the time analog 1 reached its high value

```
078 1 D or unkey
```

**Response:**

"<Time>"



## ***079: Read an Analog Low Line Time***

This command allow the user to recall the time an analog low extreme occurred. The user would normally not use this command for day-to-day operation. Because of the analog low time special words (Words 721..724), the user would normally include these words for message readback. This command is mainly used for setting up the analog system.

<079> x

### **Parameters:**

X is the analog inputs. This number must be between 1..4

### **Defaults:**

Analog high/lows are cleared on reset

### **Error Codes:**

E1 - Invalid analog line. This number must be between 1..4  
(System wide errors are listed in front of the manual)

### **Example 1:**

I want to check the time analog 1 reached its low value

079 1 D or unkey

### **Response:**

"<Time>"

## ***080: Read an Analog High Date***

This command allow the user to recall the date an analog high extreme occurred. The user would normally not use this command for day-to-day operation. Because of the analog date special words (Words 725..728), the user would normally include these words for message readback. This command is mainly used for setting up the analog system.

<080> x

### **Parameters:**

X is the analog inputs. This number must be between 1..4

### **Defaults:**

Analog high/low are cleared on reset

### **Error Codes:**

E1 - Invalid analog line. This number must be between 1..4  
(System wide errors are listed in front of the manual)

### **Example 1:**

I want to check the day analog 1 reached its high value

080 1 D or unkey

### **Response:**

"<Date> <Day>"

## ***081: Read an Analog Low Date***

This command allow the user to recall the date an analog low extreme occurred. The user would normally not use this command for day-to-day operation. Because of the analog date special words (Words 729..732), the user would normally include these words for message readback. This command is mainly used for setting up the analog system.

```
<081> x
```

### **Parameters:**

X is the analog inputs. This number must be between 1..4

### **Defaults:**

Analog high/low are cleared on reset

### **Error Codes:**

E1 - Invalid analog line. This number must be between 1..4  
(System wide errors are listed in front of the manual)

### **Example 1:**

I want to check the day analog 1 reached its low value

```
081 1 D or unkey
```

### **Response:**

```
"<Date> <Day>"
```

## ***082: Analog Line Alarm Value Program***

This command allows the user to assign both high and low alarm points to the analog inputs. The applications for this command are for monitoring high and low points like temperature, voltage, door alarms, contact closures, and any analog or contact closure condition.

```
<082> w x yyy
```

### **Parameters:**

W is the analog inputs. This number must be between 1..4

X is the alarm indicate programming variable

1 - High alarm programming

0 - Low alarm programming

YYY is the alarm point. This number must be between 000..255

The alarm tables are on the following 2 pages

### **How to use the tables for alarming:**

When choosing an alarm point locate the faceplate that is assigned to the line being alarmed. Follow the numbers and locate a position that most closely defines the desired alarm point. Select the number that averages closest to the desired alarm point and enter it for the 'YYY' variable in the command name.

### **Defaults:**

All alarms are disabled

### **Notes:**

- The tables only provide a rough approximation of the alarm point. Once the 3 digit number is entered into the alarm function a formatted number will be spoken for the actual alarm point. If you want your alarm point to be closer simply re-enter a new alarm point number that is slightly different than the previous point. Do this until you achieve the desired alarm point.

### **Error Codes:**

E1 - invalid analog line

E2 - Invalid analog alarm value

(System wide errors are listed in front of the manual)

### **Example 1:**

I want to alarm analog 1 for a high alarm at 135°F. My faceplate is 06

(I located 121°F (205) and 149°F (215). I found the mid-point of 135°F to be 210)

```
082 1 1 210 D or unkey
```

### **Response:**

"<Voltage the alarm point is at>"

**YYY is the alarm point**

Number	FC00	FC01	FC02	FC03	FC04	FC05	FC06	FC07	FC08
255	4.00	16.0	32.0	64.0	128.0	255	440	228	-042
245	3.84	15.4	30.7	61.5	123.0	245	404	208	-035
235	3.69	14.7	29.5	59.0	118.0	235	369	189	-028
225	3.53	14.1	28.2	56.5	112.9	225	334	169	-021
215	3.37	13.5	27.0	54.0	107.9	215	298	149	-014
205	3.22	12.9	25.7	51.5	102.9	205	263	130	-007
195	3.06	12.2	24.5	48.9	097.9	195	228	110	-001
185	2.90	11.6	23.2	46.4	092.9	185	192	090	006
175	2.75	11.0	22.0	43.9	087.8	175	157	071	013
165	2.59	10.4	20.7	41.4	082.8	165	122	051	020
155	2.43	09.7	19.5	38.9	077.8	155	087	031	027
145	2.27	09.1	18.2	36.4	072.8	145	051	012	034
135	2.12	08.5	16.9	33.9	067.8	135	016	-008	041
125	1.96	07.8	15.7	31.4	062.7	125	-019	-028	048
115	1.80	07.2	14.4	28.9	057.7	115	-055	-047	055
105	1.65	06.6	13.2	26.4	052.7	105	-090	-067	062
095	1.49	06.0	11.9	23.8	047.7	095	....	....	069
085	1.33	05.3	10.7	21.3	042.7	085	....	....	076
075	1.18	04.7	09.4	18.8	037.6	075	....	....	083
065	1.02	04.1	08.2	16.3	032.6	065	....	....	089
055	0.86	03.5	06.9	13.8	027.6	055	....	....	096
045	0.71	02.8	05.6	11.3	022.6	045	....	....	103
035	0.55	02.2	04.4	08.8	017.6	035	....	....	110
025	0.39	01.6	03.1	06.3	012.5	025	....	....	117
015	0.24	00.9	01.9	03.8	007.5	015	....	....	124
005	0.08	00.3	00.6	01.3	002.5	005	....	....	131
000	0.00	00.0	00.0	00.03	000.0	000	....	....	134

**YYY is the alarm point**

Number	FC09	FC10	FC11	FC12	FC13	FC14
255	-043	100	360	25.0	8	S9+60
245	-039	96	346	24.0	7	S9+60
235	-035	92	332	23.0	7	S9+50
225	-031	88	317	22.0	7	S9+50
215	-027	84	304	21.0	6	S9+40
205	-023	80	289	20.0	6	S9+30
195	-019	77	275	19.0	6	S9+30
185	-016	73	261	18.0	6	S9+20
175	-012	69	247	17.0	5	S9+20
165	-008	65	233	16.0	5	S9+10
155	-004	61	219	15.0	5	S9
145	-000	57	205	14.0	4	S9
135	004	53	191	13.0	4	S8
125	008	49	177	12.0	4	S7
115	012	45	162	11.0	4	S7
105	016	41	148	10.0	3	S6
95	020	37	134	09.0	3	S5
85	024	33	120	08.0	3	S5
75	027	29	106	07.0	3	S4
65	031	26	92	06.0	2	S4
55	035	22	78	05.0	2	S3
45	039	18	64	04.0	2	S2
35	043	14	49	03.0	1	S2
25	047	10	35	02.0	1	S1
15	051	6	21	01.0	1	S0
5	055	2	7	0.50	1	S0
0	056	0	0	0.00	1	S0

## ***083: Check Analog Alarm Points***

This command allows the checking of the alarm points set in the previous command.

```
<083> x y
```

### **Parameters:**

X is the analog inputs. This number must be between 1..4

Y is the alarm indicate programming variable

1 - High alarm programming

0 - Low alarm programming

### **How to use the tables for alarming:**

When choosing an alarm point locate the faceplate that is assigned to the line being alarmed. Follow the numbers and locate a position that most closely defines the desired alarm point. Select the number that averages closest to the desired alarm point and enter it for the 'YYY' variable in the command name.

### **Defaults:**

All alarms are disabled

### **Notes:**

- The tables only provide a rough approximation of the alarm point. Once the 3 digit number is entered into the alarm function a formatted number will be spoken for the actual alarm point. If you want your alarm point to be closer simply re-enter a new alarm point number that is slightly different than the previous point. Do this until you achieve the desired alarm point.

### **Error Codes:**

E1 - Invalid analog line

(System wide errors are listed in front of the manual)

### **Example 1:**

I want to check the high alarm setting for analog 1. My faceplate is 06

```
083 1 1 D or unkey
```

### **Response:**

"<Formatted Analog Alarm Point>"

## ***084: Check Analog Active Alarms***

This command check if an analog line is in alarm. If the line is in alarm it will indicate what alarm condition the line is in.

```
<084> x
```

### **Parameters:**

X is the analog inputs. This number must be between 1..4

### **Defaults:**

All analog alarms are disabled

### **Error Codes:**

E1 - Invalid analog line

(System wide errors are listed in front of the manual)

### **Example 1:**

I need to check if my analog 4 is in alarm.

```
084 1 D or unkey
```

### **Response:**

Either "<High Alarm>, <Low Alarm> or <Not in Alarm>"



## *Examples for Chapter 9*

**Analog Input Telemetry Lines**

The RLC-2 offers 4 analog monitoring input lines. This is a nice feature that allows the site owner to monitor analog conditions like temperature, site voltage, forward and reflected power, heat sink temperature, and much more. The RLC-2 comes set up to measure 0-25 Volts with 100mV resolution. For special applications, the input voltage will only vary a few volts. With a clip of a resistor (Revision A boards), the lifting of a jumper (Revision B boards), or a flip of a dip switch (Revision C boards), the RLC-2 will measure 0-5 Volts, giving 20mV resolution. It is important not to apply over 30 volts to the RLC-2 in the 25 Volt range or 7 volts in the 5 volt range. If this voltage threshold is exceeded, damage to the analog op amp will occur.

**Pin-Out Analog/Input P1 Connector**

Pin Number	Description
1	Ground Available
2	Contact Closure Input #4
3	Contact Closure Input #2
4	Analog Input #4
5	Analog Input #2
6	Contact Closure Input #3
7	Contact Closure Input #1
8	Analog Input #3
9	Analog Input #1

## ***Example 9-1: Configure a High Temperature Alarm***

The RLC-2 supports 4 analog input lines. These analog lines can convert most analog voltages into temperatures, voltages and signal strengths. One application is support for the LM335Z temperature sensor. This sensor converts temperature into voltage. The controller takes the voltage and converts it into a temperature for a formatted readback. The user can then take the converted number and assign it to a high and a low alarm for automated system alarming.

The steps in assigning the temperature alarm is to configure, calibrate, select and finally program the points where the alarm occur. When an alarm occurs the controller needs to assign a 'high temperature' message into drop-out message slot 1 on port 1's transmitter.

**1) Assign a temperature faceplate to analog input 1**

- 070 1 06 D or unkey ; Assigns fahrenheit faceplate to input 1

Where (1) is the analog input line, (06) is the conversion faceplate

**2) Calibration of the analog input is important to give a true reading of the input condition.**

- 073 1 0 03 D or unkey ; Assigned a minus calibration to input 1

Where (1) is the analog input line, (0) indicates minus calibration, (03) is the calibration amount. This is just an example of how to calibrate, the actual calibration varies between controllers.

**3) Choose the High alarm at 122 degrees (165 in the alarm table)**

- 082 1 1 165 D or unkey ; Assigns the high alarm at 122°F

**4) Program the high alarm event to enable the speaking of a drop-out message. We will use macro 13 (Command 183) for this purpose.**

- 064 064 2 183 01 D or unkey ; Assign macro 13 to change the drop-out message

**5) Program the coming out of alarm event to disable the speaking of a drop-out message. We will use macro 14 (Command 184) for this purpose.**

- 064 072 2 184 01 D or unkey ; Assign macro 14 to change the drop-out message

**6) Program macro 13 to simply enable port 1 drop-out message 1**

- 165 13 D or unkey ; Clear macro 13

- 168 13 045 213 414 066 D or unkey ; Speak 'High Temp. Alert'

- 168 13 169 ; Cancel responses

- 168 13 065 021 1 ; Enable drop-out message port 1

**7) Program macro 14 to simply disable port 1 drop-out message 1**

- 165 14 D or unkey ; Clear macro 14

- 168 14 045 213 414 066 111 D or unkey ; Speak 'High Temp. Alert Clear'

- 168 14 169 ; Cancel responses

- 168 14 065 021 0 ; Disable drop-out message port 1

**8) Program the Drop-out Message into message slot 10**

- 049 10 1 414 066 D or unkey ; Programs the drop-out message 'Temp. Alert'

**9) Programs the Drop-out event**

- 064 021 1 010 01 D or unkey ; Programs the drop-out message event

These commands allow the controller to speak a message, and alert the users of the system of the alarm condition. Chapter 10 examples will use this example assigned to an input line to indicate intruder alarms.

## *Temperature Sensor Hook-Up*

This figure shows the correct hook-up for the LM335Z temperature sensor. It is important to weather proof the sensors metal leads. If moisture is present the sensor may give an invalid reading. An easy way to moisture proof the sensor is using some type of hot melted glue that can be melted across the leads of the sensor. It is important not to completely cover the body of the sensor. If the body is covered internal heating will occur again causing errors in the temperature readings.

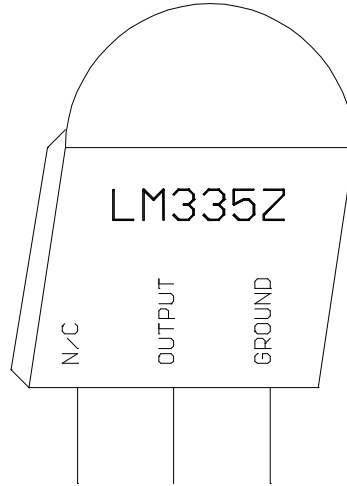

## *Reading AC Voltage with an Analog Input Line*

This figure shows the correct way of reading the AC voltage from the 110VAC outlet without damaging the controller's analog inputs. It is important to use a transformer to isolate the AC line from the controller. The controller needs its analog input set for 00.0 .. 25.0 volts. Set the faceplate to type 05. To calibrate the voltage use a calibrated voltage meter. Read the line voltage and note this value. Then adjust the analog output to a value:

Analog Output = (AC input voltage)  $\div$  10.

Voice response will indicate to the nearest volt the actual AC voltage.

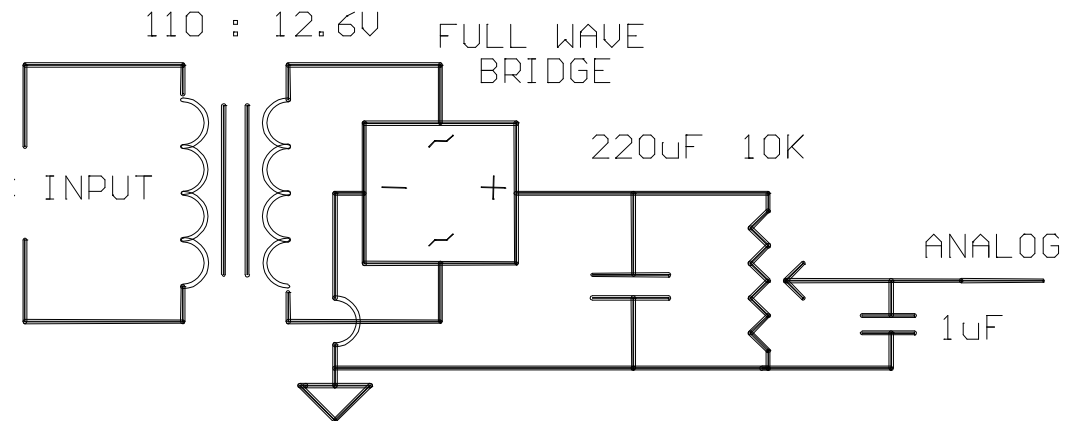

## *Reading Wind Speed with Analog Input 4*

The RLC-2 supports wind speed conversion with pulse style wind speed sensors. Analog input 4 is the only analog channel that supports this type of device. In order for the sensor to function correctly, the voltage divider switch (or jumper on Revision 'B' boards) must be off, and the voltage switch must be on. This provides the wind sensor with voltage to power the TTL pulse output.

Steps:

- 1) Set your analog faceplate to 15
  - Command 070 4 15
  
- 2) Verify the voltage divider switch or jumper is OFF
  - Revision 'A' boards do not have this switch or jumper (See Command 070)
  
- 3) Verify the voltage power switch is ON
  - Revision 'A' boards do not have this switch or jumper (See Command 070)
  - Revision 'B' boards do not have this switch or jumper (See Command 070)

On Revision 'A and B' boards add an external resistor (10 K ohm) between +12V and Analog 4.

- 4) Connect your wind speed sensor to Analog input 4
  - Pin 4 on the Analog\Input connector
  
- 5) No calibration should be needed
  - Read the analog input using Command 075 4
    - No wind = Word 'Calm'
    - Maximum wind = 100 MPH

## ***Chapter 10: Input and Output Lines***

These commands deal with the 4 contact closure inputs and the 8 latched output lines.

## ***085: Read Input Lines***

This command allows the user to read any of the input lines. The line is either High or Low. A low indicates the input line is at ground or 0V state. A high indicates the input line is an open or above 4V.

```
<085> x..x
```

### **Parameters:**

X..X are the input lines. These numbers can vary between 1..4

- You can read several input lines at once by entering all the lines in 1 sequence

### **Defaults:**

Input lines are high (open)

### **Error Codes:**

E1 - Invalid input line

(System wide errors are listed in front of the manual)

### **Example 1:**

Input 1 is the door alarm. I need to check if it is high or low for the event table programming.

```
085 1 D or unkey
```

### **Response:**

"<Input Line> is <High> or <Low>"



***086: Output Line 1 On***  
***087: Output Line 1 Off***  
***088: Output Line 2 On***  
***089: Output Line 2 Off***  
***090: Output Line 3 On***  
***091: Output Line 3 Off***

These commands provide a short-cut to access the lower 3 output lines. They are provided so the user does not need a macro to turn on an output line with an event table change. Because these commands do not contain any additional data following the command name, the user can simply call any of these 6 commands when output line control is needed.

<086..091>

**Parameters:**

There are no parameters for these commands

**Defaults:**

All output lines default off

**Notes:**

- When an output line is Off, the line becomes a high impedance state. When the output line is turned on, it becomes a very low impedance. Use a ohm meter when checking the lines, not a voltage meter.

**Error Codes:**

(System wide errors are listed in front of the manual)

**Response:**

There are no responses for these commands

## ***092: Output Line #..# On***

This command allows the user to turn on any one of the 8 output lines. This command requires additional data to indicate what lines need to be turned on. The previous output line commands did not require any additional data.

```
<092> x..x
```

### **Parameters:**

X..X are the output lines. These numbers can vary between 1..8

- You can turn on several output lines at once by entering all the lines in 1 sequence

### **Defaults:**

All output lines default off

### **Error Codes:**

E1 - Invalid output line. The number must range between 1..8

(System wide errors are listed in front of the manual)

### **Example 1:**

I want to turn on outputs 1 3 5 7 in 1 command

```
092 1 3 5 7 D or unkey
```

### **Response:**

"<Output Line> ON"

## ***093: Output Line #..# Off***

This command allows the user to turn off any one of the 8 output lines. This command requires additional data to indicate what lines need to be turned on. The previous output line commands did not require any additional data.

```
<093> x..x
```

### **Parameters:**

X..X are the output lines. These numbers can vary between 1..8

- You can turn off several output lines at once by entering all the lines in 1 sequence

### **Defaults:**

All output lines default off

### **Error Codes:**

E1 - Invalid output line. The number must range between 1..8

(System wide errors are listed in front of the manual)

### **Example 1:**

I want to turn off outputs 1 3 5 7 in 1 command

```
093 1 3 5 7 D or unkey
```

### **Response:**

"<Output Line> OFF"

## 094: Check Output Lines

This command allows the user check the current condition of any output line. This command requires additional data to indicate what lines need to be turned on. The previous output line commands did not require any additional data.

```
<094> x..x
```

### Parameters:

X..X are the output lines. These numbers can vary between 1..8

- You can turn check several output lines at once by entering all the lines in 1 sequence

### Defaults:

All output lines default off

### Error Codes:

E1 - Invalid output line. The number must range between 1..8

(System wide errors are listed in front of the manual)

### Example 1:

I need to check what condition outputs 1 3 5 7 are currently in.

```
094 1 3 5 7 D or unkey
```

### Response:

"<Output Line> <ON/OFF>"

## *Examples for Chapter 10*

## *Example 10-1: Configure a Door Alarm*

The RLC-2 supports 4 contact closure input lines. These lines are used to monitor contact closure events. The user can use these events for automated system alarming.

The steps in assigning a door alarm is to hook-up the magnetic door switch and assign the door open state and the door closed state. When an door open condition occurs the controller needs to assign a 'Door Open' message into drop-out message slot 2 on port 1's transmitter.

**1)** Program the input just went low event to drop-out message 2. We will use macro 15 (Command 185) for this purpose.

- 064 076 2 185 01 D or unkey ; Assign macro 15 to change the drop-out message

**2)** Program the input just went high event to disable the speaking of a drop-out message. We will use macro 16 (Command 186) for this purpose.

- 064 080 2 186 01 D or unkey ; Assign macro 16 to change the drop-out message

**3)** Program macro 15 to simply enable port 1 drop-out message 2

- 165 15 D or unkey ; Clear macro 15  
 - 168 15 045 148 311 066 D or unkey ; Speak 'Door Open Alert'  
 - 168 15 169 ; Cancel responses  
 - 168 15 065 022 1 ; Enable drop-out 2 message port 1

**4)** Program macro 16 to simply disable port 1 drop-out message 2

- 165 16 D or unkey ; Clear macro 16  
 - 168 16 045 148 311 066 111 D or unkey ; Speak 'Door Open Alert Clear'  
 - 168 16 169 ; Cancel responses  
 - 168 16 065 022 0 ; Disable drop-out message port 1

**5)** Program the Drop-out Message into message slot 11

- 049 11 1 148 311 D or unkey ; Programs the drop-out message 'Door Open'

**6)** Programs the Drop-out event

- 064 022 1 011 01 D or unkey ; Programs the drop-out message event

These commands allow the controller to speak a message, and alert the users of the system of the alarm condition. Chapter 9 examples will use this example assigned to an analog input line to indicate high temperature status.

# *Magnetic Door Switch Drawing*

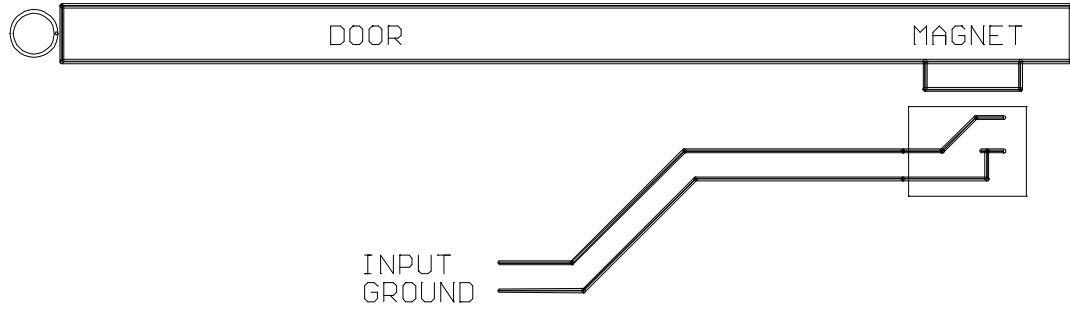

## *Logical Latched Output Lines*

The RLC-2 offers 8 logical control lines for site control. Because the output lines are open collector, the user will not measure any voltage on the output lines, only an open or a ground. In order to check the condition of the control lines, a meter set to resistance will be needed. The meter will read an open when the control line is off and a virtual ground when the control line is on. When using a semiconductor device as a latch, certain current limitations are imposed. The Output used can sink (apply a ground), of 150mA. If this current is exceeded, the Output will short and destroy the device. See figure below on how to connect a relay to one of the output lines. (See Command Listing for output control line commands).

**Pin-Out Logical Latched Outputs P2 Connector**

Pin Number	Function
1	Ground Available
2	Output 8
3	Output 6
4	Output 4
5	Output 2
6	Output 7
7	Output 5
8	Output 3
9	Output 1



## *Output Line Relay Driver Drawing*

This figure shows correct relay driving using one of the 8 output lines on the controller. It is important to have a flyback diode across the relays coil for inductive pulse protection.

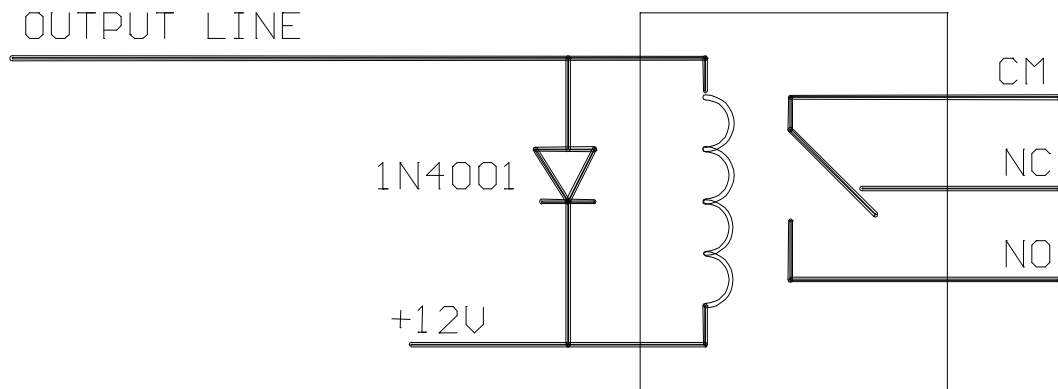

## ***Logical Input Lines***

The RLC-2 offers the user 4 logical input lines. These lines recognize an open/ground input change. These lines are internally pulled up to +5 Volts and zener diode clamped to 5 Volts. This allows direct interface to higher voltage inputs that do not exceed +15 Volts. The application to site users is great: door open/closed magnetic contacts, local site controlled switches, and site power monitoring relays. See figures below for some circuit installation procedures. These are just a few of the applications that the logical input lines can be used for.

### **Pin-Out Analog Inputs Outputs P2 Connector**

Pin Number	Function
1	Ground Available
2	Input 4
3	Input 2
4	Analog Input 4
5	Analog Input 2
6	Input 3
7	Input 1
8	Analog Input 3
9	Analog Input 1

## *Input line reading AC power fail Drawing*

This figure shows the correct way of hooking-up an AC fail alarm relay used to indicate AC failure. When the AC is present the relay contact will be closed. This will indicate to the controller a logic low is normal (AC is present), and a logic high is alarm (AC is not present).

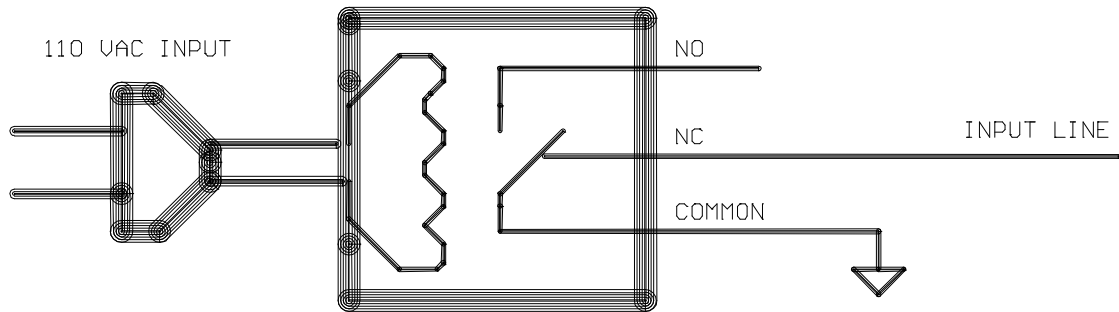

## Chapter 11: Doug Hall RBI-1, RLC-ICM and Misc.Remotes

The following commands deal with the Doug Hall Electronics RBI-1, and the Link Communications Inc. RLC-ICM interface controllers. The last commands in this section deal with serial and pulse remote base formats.

### Doug Hall RBI-1 Interface

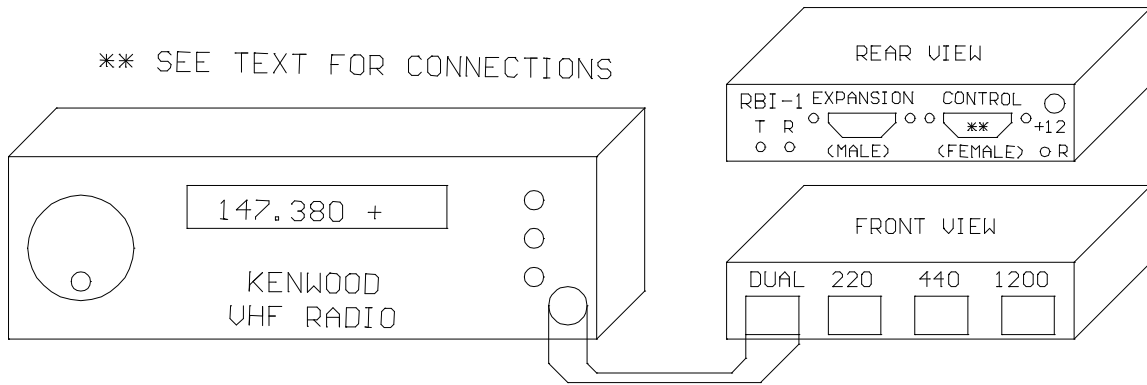

## *A Brief Description on how to use: Remote Base Functions*

The RLC-2 can control many common remote base radios. The controller can directly control ICOM and Kenwood HF radios. Control of Kenwood mobile radios is accomplished using the Doug Hall Electronics RBI-1 (See Remote Base section of the manual for Doug Hall RBI-1 information). ICOM IC900/901 band modules are supported using the Link Communications RLC-ICM interface. BCD and channel selected remotes are also supported.

### **HF Remote Bases:**

The RLC-2 will directly control most ICOM and Kenwood HF radios that have an RS-232 interface available. Control of the remotes is accomplished using the RLC-2 RS-232 serial port. The serial port can also be used by your terminal, modem or TNC. When interfacing the Audio, COR and PTT inputs, a link port must be used.

### **Doug Hall RBI-1 Remote Base:**

The RLC-2 will control an external Doug Hall RBI-1 interface using 3 of its output lines. Interfacing the RBI-1 is accomplished by using Outputs 8,7,6. The output lines will shift the needed data out to the RBI-1 which will then control the attached radio. Most features of the radio are supported like PL frequency, encode/decode, frequency, offset, memory, radio power, and power level. The RBI-1 will support 4 bands (2M, 220, 440, 1.2Ghz.). Link Communications Inc. only supports the RBI-1. You can purchase the interface from Doug Hall Electronics. (See Remote Base section for order information).

### **Link Communications RLC-ICM Remote Base Interface:**

The RLC-2 supports the RLC-ICM interface using 3 of its output lines. The RLC-ICM allows remote control of the ICOM IC900/901 band modules. The RLC-ICM supports 5 bands (10M, 6M, 2M, 220, 430-440). The interfacing of the RLC-ICM is accomplished using Outputs 8,7,6. These lines contain the data to control the interface. Contact Link Communications Inc. for more on the RLC-ICM.

### **Serial BCD data:**

The RLC-2 supports serial shifting BCD data using 3 of the output lines. The user can enter up to 20 digits to be shifted out. Outputs 8,7,6 are used to shift the data out. An external shift register is needed to decode the serial data into parallel data.

### **Parallel BCD data:**

The RLC-2 supports parallel shifting BCD data using 4 of the output lines. The user can enter up to 20 digits to be shifted out. Outputs 1,2,3,4 are used to shift the data out. An external shift register is needed to decode the multiple parallel data into usable data. The common use for this type of data is in channel selectable radio that require 4 bits to be set to access 16 channels.

## 095: Enter Frequency Plus Offset for RBI-1, RLC-ICM

This command allows the entry of frequency plus offset data for the RBI-1 and the RLC-ICM remotes. Other features like power, memory, PL are entered in separate commands.

<095> xxxxxx y

**Parameters:**

XXXXXX is the actual frequency

- 29.600 simplex is entered as 296002 (Voice: 29<point>60 S)
- 147.380 plus is entered as 1473801 (Voice: 147<point>38 plus)
- 1290.00 minus is entered as 12900000 (Voice:1290<point>00 minus)

Y is the offset

Offset Number	Offset
0	Minus
1	Plus
2	Simplex
3	Minus 20 Mhz in 1200mhz band

**Defaults:**

There are no defaults for this command

**Notes:**

- After the frequency data is entered the controller waits the RBI-1 timer (See Command 50,51,52) before sending the data. This allows several items to be changed before the controller sends the batch to the remotes.

**Error Codes:**

E1 - To much data is present

E2 - Invalid frequency band. Bands can only be

28,29,50,51,52,53,54,140,150,160,220,430,440,1240,1250,1260,1270,1280,1290

E3 - Invalid frequency. Frequency needs to be 3,4,5 digits followed by 3 digits of frequency data followed by the offset data.

(System wide errors are listed in front of the manual)

**Example 1:**

I want the remote to go to 145.250 - repeater.

095 1452500 D or unkey

**Response:**

"<Frequency> <Offset>"

## ***096: Set PL Frequency, Encode On-Off, Decode On-Off***

This command controls the setting of the PL information, Encode and Decode controls. Other features like power, memory, frequency are entered in separate commands.

<096> xx y z

### **Parameters:**

XX is the PL frequency information, (XX) TS-64 PL Frequency Table (RLC-ICM Only)

Tone #	Frequency	Tone #	Frequency	Tone #	Frequency
00	250.3	22	156.7	44	177.3
01	233.6	23	146.2	45	183.5
02	218.1	24	136.5	46	189.9
03	203.5	25	127.3	47	196.6
04	186.2	26	118.8	48	199.5
05	173.8	27	110.9	49	206.5
06	162.2	28	103.5	50	229.1
07	151.4	29	94.8	51	254.1
08	141.3	30	82.5	52	44.4
09	131.8	31	71.9	53	39.6
10	123.0	32	63.0	54	37.9
11	114.8	33	58.8	55	36.6
12	107.2	34	56.8	56	35.4
13	100.0	35	54.9	57	33.0
14	88.5	36	53.0	58	97.4
15	77.0	37	51.2	59	91.5
16	241.8	38	49.2	60	85.4
17	225.7	39	47.5	61	79.7
18	210.7	40	69.4	62	74.4
19	192.8	41	159.8	63	67.0
20	179.9	42	165.5	....	....
21	167.9	43	171.3	....	....

(XX) RBI-1 Kenwood Frequency Table (RBI-1 Only)

Tone #	Frequency	Tone #	Frequency	Tone #	Frequency
00	67.0	14	110.9	28	179.9
01	71.9	15	114.8	29	186.2
02	74.4	16	118.8	30	192.8
03	77.0	17	123.0	31	203.5
04	79.7	18	127.3	32	210.7
05	82.5	19	131.8	33	218.1
06	85.4	20	136.5	34	225.7
07	88.5	21	141.3	35	233.6
08	91.5	22	146.2	36	241.8
09	94.8	23	151.4	37	250.3
10	97.4	24	156.7	....	....
11	100.0	25	162.2	....	....
12	103.5	26	167.9	....	....
13	107.2	27	173.8	....	....



Y is the PL Encode (Generate) control

- 1 - Encode PL on Transmit
- 0 - Cancel PL Encode

Z is the PL Decode (Receive) control

- 1 - Require PL on Receive
- 0 - Cancel PL Decode requirement

**Defaults:**

PL tone set to 00, encode and decode are off.

**Error Codes:**

- E1 - Invalid PL frequency (See Tables above)
- E2 - Invalid PL encode mode
- E3 - Invalid PL decode mode

(System wide errors are listed in front of the manual)

**Example 1:**

I want PL encode and decode enabled with a PL of 100.0Hz. I am using an RBI-1 interface

096 11 1 1 D or unkey

**Response:**

"PL <PL number> Transmit <ON> Receive <ON>"

## ***097: Recall Memory Channels on RBI-1***

This command only is available on the RBI-1 interface running version 3.XX RBI-1 software. This command will recall memory channels 01..20.

```
<097> xx
```

### **Parameters:**

XX is the memory channel number 01..20

### **Defaults:**

There are no defaults for this command

### **Notes:**

- Only RBI-1's running version 3.XX software support this feature. The RLC-ICM does not support this feature.

### **Error Codes:**

E1 - Invalid memory channel

(System wide errors are listed in front of the manual)

### **Example 1:**

I want to recall the weather channel on my Kenwood TH-241. I pre-programmed the memory into number 08.

```
097 08 D or unkey
```

### **Response:**

"Radio Look-Up <Memory Channel>"

## ***098: Set Power on the RBI-1***

This command allows the user to change the power levels on the RBI-1. This command is not supported on the RLC-ICM interface. The power on the RLC-ICM is set using a jumper block on the radio interface module.

```
<098> x
```

### **Parameters:**

X is the power control function

- 0 - Low Power
- 1 - High Power
- 2 - Medium Power

### **Defaults:**

Power defaults to low

### **Notes:**

- The RLC-ICM does not support this feature.

### **Error Codes:**

E1 - Invalid power level

(System wide errors are listed in front of the manual)

### **Example 1:**

I need to increase my remote to high power to get into a distance repeater

```
098 1 D or unkey
```

### **Response:**

"Power at <Power Level>"

## ***099: Turn RBI-1 Radio Band Power On-Off***

This feature allows an unused module to be turned off. The module selected is the last module that frequency data was sent to. This feature is not supported on the RLC-ICM interface.

<099> x

### **Parameters:**

X is the power control function

- 1 - Turn the radio module power ON
- 0 - Turn the radio module power OFF

### **Defaults:**

All modules power is ON

### **Notes:**

- The RLC-ICM does not support this feature.

### **Error Codes:**

E1 - Invalid power control level

(System wide errors are listed in front of the manual)

### **Example 1:**

I want to shut off my 2 meter module that I just finished using.

099 0 D or unkey

### **Response:**

"Radio Power <ON/OFF>"

## ***100: Reset External Interface***

This command allows an external reset of the remote base interface. When the controller resets it automatically resets the external interface. This command is used when control is lost with the external interface.

<100>

### **Parameters:**

There are no parameters for this command

### **Defaults:**

There are no defaults for this command

### **Error Codes:**

(System wide errors are listed in front of the manual)

### **Example 1:**

I seem to have lost communications with my RBI-1. I need to remotely reset is to regain control.

100 D or unkey

### **Response:**

"Radio Start"

## 101: Configure the RLC-ICM Module

This command pertains only to the RLC-ICM interface. Because there are so many radio modules that the RLC-ICM supports with different modes, offsets, and functions a special set-up command is needed to simplify the configuration of this interface.

<101> x ss

### Parameters:

X is the band module requested

- 1 - Module is plugged into connection 1
- 2 - Module is plugged into connection 2
- 3 - Module is plugged into connection 3
- 4 - Module is plugged into connection 4

SS is the set-up code to assign to the requested module

(It may be necessary to assign several set-up codes to each module)

- First you need to assign what frequency module is plugged into what slot

SS (the setup code)	Description
00	28 Mhz Module
05	50 Mhz Module
10	140..160 Mhz Module
15	220 Mhz Module
20	430..440 Mhz Module
25	1200 Mhz Module (not currently active)

- Second, you must tell each band module what size of offset to use when you select a plus or minus offset with Command 095.

SS (the setup code)	Description
30	100 KHz Offset
35	500 KHz Offset
40	600 KHz Offset
45	1 Mhz Offset
50	1.6 Mhz Offset
55	1.7 Mhz Offset
60	5 Mhz Offset

65	12 Mhz Offset
70	20 Mhz Offset

- Setup codes 75 and 80 are reserved for special offset memories, which are not yet supported.
- Once you have a frequency into the module you use the below setup codes disable and enable transmitting on individual modules:

SS (the setup code)	Description
85	Transmit and Receive Enabled
90	Transmit Disabled (receive only)
95	Transmit and Receive Disabled (module turned off)

- If you have properly entered the above commands, the RLC-Icom is set up and ready to use. To enter frequencies, turn PL on and off, etc., use the RBI-1 commands in this section of the manual.

**Defaults:**

Refer to your RLC-ICM manual for defaults

**Error Codes:**

E1 - Invalid module requested

(System wide errors are listed in front of the manual)

**Example 1:**

I want to assign 140 module to slot 3, then assign a 600 kHz offset used on that module.

101 3 10 D or unkey

**Then**

101 3 40 D or unkey

**Response:**

"Radio Set-up Complete"

## ***102: Recall Frequency***

This command recalls the frequency last entered into the controller.

<102>

### **Parameters:**

There are no parameters for this command

### **Defaults:**

There are no defaults for this command

### **Notes:**

- This command only **currently** recalls the last frequency entered into the controller. A future release will allow you to recall the frequency of a specific band.

### **Error Codes:**

(System wide errors are listed in front of the manual)

### **Example 1:**

I want to recall what the last frequency entered was

102 D or unkey

### **Response:**

"<Frequency> <Offset>"



## ***103: Recall All Remote Variables***

This command allows all set-up features to be recalled.

<103>

### **Parameters:**

There are no parameters for this command

### **Defaults:**

There are no defaults for this command

### **Notes:**

- This command only **currently** recalls the last features entered into the controller. A future release will allow you to recall the features of a specific band.

### **Error Codes:**

(System wide errors are listed in front of the manual)

### **Example 1:**

I want to recall what is entered for the remote

103 D or unkey

### **Response:**

- 1) "<Frequency> <Offset>"
- 2) "PL <PL Tone> Transmit <ON/OFF> Receive <ON/OFF>"
- 3) "Radio Look-Up <Memory Channel>"
- 4) Power At <Power Level>"
- 5) Radio Power <ON/OFF>"

## ***104: External Serial Data Send - Parallel BCD Controller***

This command serially sends data out 2 output lines for support of external serial --> parallel controllers. This command is used to expand the output lines, external BCD controller support, and any function that requires serial data.

```
<104> x..x
```

### **Parameters:**

X..X are the BCD digits to be sent serially

Output 7 is the serial data

Output 8 is the serial clock

Output 6 can be used as a serial enable/disable function

### **Defaults:**

There are no defaults for this command

### **Notes:**

- This command uses the same output lines as the RBI-1 and RLC-ICM.

### **Error Codes:**

E1 - Too much data. This command can handle up to 20 digits of BCD data

(System wide errors are listed in front of the manual)

### **Example 1:**

I want to send 4 digits to my external controller. The data is 5250

```
104 5 2 5 0 D or unkey
```

### **Response:**

"Frequency is <Entered Data>"

## *110: Pulse Output Line 'X' 'Y' Times*

This command allows the user to pulse a selected output line, from 1 to 9 times. This feature is used by some radios for remote base support.

```
<110> x y
```

### **Parameters:**

X is the output line. This number must range from 1..8

Y is the number of times to pulse the output line. This number must range from 1..9

### **Defaults:**

There are no defaults for this command

### **Error Codes:**

E1 - Invalid output line. The output line must be between 1..8

E2 - Invalid pulse number. This number must be between 1..9

(System wide errors are listed in front of the manual)

### **Example 1:**

I need to move my external remote up 7 channels. The output line I use is out 4

```
110 4 7 D or unkey
```

### **Response:**

"Out Control <Output Line> <Number of Pulses> Times"

## *Chapter 11 Examples*

## ***Example 11-1: I need to fully configure the RLC-ICM***

In order for the RLC-ICM module to operate correctly, the user must fully configure the interface prior to functional operation. Any configured modules that have no radios connected must be disabled from the interface. This example will cover interfacing 3 modules to the RLC-ICM. Modules will be configured differently from what the default configuration is.

Modules for our example:

- 10 Meters on port 1
- 6 Meters on port 3
- 2 Meters on port 4

Note that module 2 has no connection. Also note that none of these modules is correctly connected to the interface.

1) Configure module 1 for 10 meters using Command 101

- 101 1 00 D or unkey ; Voice response "Radio Set-up Complete"

Where (1) indicates module number, (00) indicates 10 meter module

2) Configure module 2 for no radio and turn off module

- 101 2 25 D or unkey ; Voice response "Radio Set-up Complete"

Where (2) indicates module number, (25) indicates no module

-101 2 95 D or unkey ; Voice response "Radio Set-up Complete"

Where (95) disables the modules receive and transmit

3) Configure module 3 for 6 meters

- 101 3 05 D or unkey ; Voice response "Radio Set-up Complete"

Where (05) indicates 6 meter module

4) Configure module 4 for 2 meters

- 101 2 10 D or unkey ; Voice response "Radio Set-up Complete"

Where (10) indicates 2 meter module

- Now the RLC-ICM is ready for operation.
- When the module receives frequency data it puts the selected module into receive only mode.
- Remember to set the RLC-ICM's radio port on the controller to expect active 'LOW' COR signals.

RLC-ICM test points are located on J10. Pin 5 is located closest to the bottom of the board.

\* 1) Pin 1 indicates valid frequency data received

\* 2) Pin 2 indicates valid set-up data was received

\* 3) Pin 3 indicates an error was received in the transmittal

4) Pin 4 provides a 1 sec. on/off pulse

5) Pin 5 provides a ground reference

\* Each test point will go from 0v to 5v for 10 seconds if the condition is true

## ***Example 11-2: I want to send several items the RBI-1***

I have an RBI-1 interface connected to by RLC-2. The connected radio ports are 2 meter, and 440 Mhz. I need to set-up the radios to some preset values that can be easily called from the controller. I will use macro 45 to set-up to 2 meter module and macro 46 for the 440 module. The 2 macros can not be called at the same time due to serial data overrun. They can be called separately by a user.

### 1) 2 meter module

- Set the frequency to 147.380 plus offset
- Set PL frequency from 100 hertz, receive pl off, transmit pl on
- Set High power
- Turn module power on

### 2) 440 module

- Set the frequency to 444.500 plus offset
- Set PL 100 hertz, receive pl off, transmit pl off
- Set Low power
- turn module power off

### 3) 2 meter modules macro 45

- |   |                                |
|---|--------------------------------|
| - 165 45 D or unkey                     | ; Clear module 45              |
| - 168 45 045 384 449 002 273 D or unkey | ; Voice 'Set Up 2 Meter        |
| - 168 45 169 D or unkey                 | ; Cancel responses             |
| - 168 45 095 147380 1 D or unkey        | ; Set the frequency and offset |
| - 168 45 096 25 1 0 D or unkey          | ; Set the PL to 100hz          |
| - 168 45 098 1 D or unkey               | ; Set high power               |
| - 168 45 099 1 D or unkey               | ; Turn the radios power on     |

### 4) 440 Mhz modules macro 46

- |   |                                |
|---|--------------------------------|
| - 165 46 D or unkey                     | ; Clear module 46              |
| - 168 46 045 384 449 004 022 D or unkey | ; Voice 'Set Up 440            |
| - 168 46 169 D or unkey                 | ; Cancel responses             |
| - 168 46 095 444500 1 D or unkey        | ; Set the frequency and offset |
| - 168 46 096 25 0 0 D or unkey          | ; Set the PL to 100hz          |
| - 168 46 098 0 D or unkey               | ; Set low power                |
| - 168 46 099 0 D or unkey               | ; Turn the radios power off    |

The user can now execute macro 45,46 to set-up the 2 meter and 440 remotes on the RBI-1.

## ***Building a cable to interface the RLC-ICM/RBI-1 Interfaces***

The cable used to communicate with the RLC-ICM/RBI-1 consists of 2 cables summed into a single connector that connects to the interface.

Cable 1 is the audio cable

Pin 1	<b>Ground Pin 9</b>
Pin 2	No Connect
Pin 3	<b>PTT Pin 8</b>
Pin 4	<b>Audio Out Pin 5</b>
Pin 5	<b>Audio In Pin 6 *</b>
Pin 6	No Connect
Pin 7	<b>COR Pin 7</b>
Pin 8	No Connect
Pin 9	No Connect

Cable 2 is the serial data cable

Pin 1	No Connect
Pin 2	<b>Clock Pin 4</b>
Pin 3	<b>Reset Pin 1</b>
Pin 4	No Connect
Pin 5	No Connect
Pin 6	<b>Data Pin 3</b>
Pin 7	No Connect
Pin 8	No Connect
Pin 9	No Connect

\* Audio on the RLC-ICM is discriminator audio. User must install appropriate audio de-emphasis jumper.

\* Audio on the RBI-1 is non-discriminator audio. User must remove appropriate audio de-emphasis jumper.

The female DB-9 on the RLC-ICM/RBI-1 is used to pass data into the interface. The above tables **'bold'** typeface indicates what connections are made to this connector. Pin #2 will not be connected on this connector. The **COR** output from the RLC-ICM is low when active. The COR output from the RBI-1 is high when active. All other signals can be interfaced without any special consideration.

## ***Doug Hall RBI-1 Information***

The following is the Doug Hall Electronics information available for the RBI-1 remote base interface. Link Communications inc. does not sell the RBI-1 interfaces, only supports the interface in the software. For more information on the RBI-1 contact Doug Hall Electronics at the below address or phone number.

Doug Hall Electronics

815 E. Hudson St.

Columbus, Ohio 43211

VOICE: +(614)261-8871

FAX: +(614) 261-8805



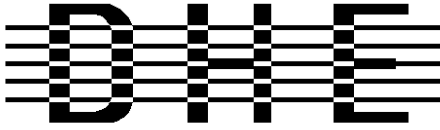

Doug Hall Electronics  
 815 E. Hudson St.  
 Columbus, Ohio 43211  
 VOICE: +(614)261-8871  
 FAX: +(614) 261-8805

## INTRODUCTION

The DHE Remote Base Interface (RBI-1) Adapts the Kenwood series TM-X21 and TM-X31 mobile radios to several brands of Repeater Controllers. The RBI model 1 converts the serial data stream from the Controller and Directly controls the Kenwood Mobile radio. All connections to the Kenwood radio are made thru the microphone jack. In the maximum configuration using a Kenwood TM-701 Dual Band Mobile you can control Frequency, CTCSS encode On/Off, RF power level, Offset, Power On/Off, and Band. This is all still accomplished thru the microphone jack.

The RLC-2 Format supports the following functions:

Full frequency control, 4 ports/radios, and 4 bands.

Transmitter power HI/MED/LOW

CTCSS Frequency select, Encode on/off, Decode on/off.

-20 and -12 Mhz offsets on 1200.

Memory Recall of 20 channels

The Supported Kenwood Mobile Radios are as follows:

<u>140</u>	<u>220</u>	<u>440</u>	<u>1200</u>	<u>DUAL</u>	
TM-221	TM-321	TM-421	TM-521	TM-621+	TM-721+
TM-231	TM-331	TM-431	TM-531	TM-631+	TM-731+
TM-241		TM-441	TM-541		TM-701+
+ Dual Banders					

Copyright (c) 1996 Doug Hall Electronics.

All Rights reserved

Specifications subject to change without notice

## SPECIFICATIONS

Microprocessor: INTEL 87C51 Series 12MHz

### Connections:

Power: RCA Phono + center pin.

Controller: 9 Pin female "D" Connector

Expansion: 9 Pin male "D" connector.

Radios: 4 8 Pin Modular Compatible with Kenwood PG-4H cable.

1 PG-4H provided. Additional cables available from Kenwood or DHE.

Adjustments: "T" (VR1) Radio transmit audio level adjust.

"R" (VR2) Radio receive audio level adjust.

Audio: Radio Transmit 0.050V to 2.5V Input

Impedance 15K.

Radio Receive 0.020V to 2.5V Output

Impedance 5K.

"S" Meter output: 0 to +5V 0V = no signal, 5V = > "S" 9.

Output impedance approx 5K.

Expansion output: 8 outputs, ground active, Sink 500mA each, 1A maximum total.

Power Requirements: +10 to +14 Vdc @ 23mA.

Size: 1.5" X 5.1" X 5.5"

Copyright (c) 1996 Doug Hall Electronics.

All Rights reserved

Specifications subject to change without notice.

## INSTALLATION

Place or mount the RBI in close proximity to the Kenwood mobile radio to be used. Connect the RBI with the provided PG-4H Cable from the 8 pin modular jack marked "RADIO" to the Kenwood Microphone jack. Only Port 1 (140/DUAL) will support a Dual Band radio. Port 1 is the only Port the 140 Mhz radio can be connected.

The RBI will support all 4 bands (140/220/440/1200) as follows:  
If Port one is filled, Port 2 is for 220 only, Port 3 is for 440 only, Port 4 is for 1200 only. Basically, if the selected band is unavailable on Port 1 it will go to the port hard assigned to that band.

J2	Line Name	RLC-2 Connections
1	RBI-1 RESET	3 RLC-2 Output #6, P2
2	"S" Meter output	(Analog Input for Signal Strength)
3	Data	6 RLC-2 Output #7, P2
4	Clock/Strobe	2 RLC-2 Output #8, P2
5	Kenwood TX Audio (T Pot)	4 RLC-2 Link Connector Port
6	Kenwood RX Audio (R Pot)	5 RLC-2 Link Connector Port
7	COS from Kenwood RX	7 RLC-2 COR Input (Must select Active High COR)
8	PTT to Kenwood TX	3 RLC-2 PTT Output
9	Ground	1 RLC-2 Ground Connection (On Link Ports Only)

Audio receive level from the Kenwood to the Controller is controlled by VR2 (R). The audio level from the Controller to the Kenwood is adjusted by VR1 (T). Refer to your manuals for additional adjustments in your controller.

## RADIO SETUP

The Kenwood radio's need certain parameters setup before they can operate from the RBI. Things such as STEP, etc. Since the memory channels in the radio aren't used we will reset the radio to default on all setup options. This can be found in your Kenwood operating guide.

TM-701	Hold the MR key down during power on to reset.
TM-X21	Hold the VFO/M and M.IN keys down during power on to reset.
TM-621/721	Hold the F key down during power on to reset.
TM-631/731	Hold the MR key down during power on to reset.
TM-X31	Hold the MR key down during power on to reset.
TM-X41	Hold the VFO key down during power on to reset.

Copyright (c) 1996 Doug Hall Electronics.

All Rights reserved

Specifications subject to change without notice.

## RADIO SETUP CONT...

- Set the step size to 5KHz. (25Khz on 1200 Mhz units)
- Set dual band radio's to single band.
- Set power to desired setting. Remember, remote base transmitters can have a high duty cycle because it will be transmitting during all activity on the Repeater side. The mobile radio's used in a remote base configuration should be set to low power in most cases.
- Set VFO/MEM to VFO for external frequency input.
- Set CTCSS for desired frequencies. When using TM-X31/X41 series it will be set by the controller and will override your initial setting.
- Set CTCSS Decode to off.
- Set ABC and AL to off on models that support it.
- Turn off Repeat functions.
  
- Once these have been set, connect the Mike jack to the RBI. Reset the RBI to initialize the radio to the controller and get them in sync.
- Any time there is manual changes from the radio front panel, the RBI and the Radio can get out of sync. This will require a RBI reset to correct. We recommend hooking the reset line from the RBI to a toggled User function output.
- Initialize the User function to "1" on and save those in all your Macro's or the reset line will be held low and disabled. To reset just interrogate the user function, this will toggle the reset line and reset the RBI.

## SUPPORT CROSS REFERENCE

FUNCTION	CTCSS ENCODE	CTCSS SELECT	CTCSS DECODE	MULTI BAND	RF PWR POWER
GENERIC	Y	Y	Y	Y	Y
<u>KENWOOD</u>					
TM-X21	Y	N	N		N
TM-X31	Y	Y	Y		Y
TM-X41	Y	Y	Y		Y
TM-621/721	Y	N	N	Y	N
TM-631/731	Y	N	N	Y	N
TM-701	Y	Y	Y	Y	Y

Copyright (c) 1994 Doug Hall Electronics.  
 All Rights reserved  
 Specifications subject to change without notice.

## ***Chapter 12: HF Remote Base Radio***

This chapter deals with the operation of the HF remote base controller. The controller is generic between radios. Only the software type differs between Icom, Kenwood, Yaseu.

### ***Connection to the RLC-2 for a Serial radio***

The RLC-2 supports frequency programming of a remote HF radio (Icom or Kenwood). The interfacing to these radios is accomplished using the RLC-2 serial port. It is important to connect both the RX and TX lines to your radios RS-232 port. Do Not Connect the RLC-2 RS-232 port directly to your TTL input of your radio or damage to the RLC-2 and your radio serial interface will occur. The serial radio interface was tested on an Icom IC-725, a Kenwood TS-450 and a Yaesu FT-900AT.

## *105: HF Mode Configure*

This command configured what port the HF remote base is on along with assigning the first digit of the remote prefix.

```
<105> x y
```

### **Parameters:**

X is the port the HF remote base is connected to

- 1 - Port 1
- 2 - Port 2
- 3 - Port 3

Y is the remote prefix used when in remote base mode

### **Defaults:**

(X) is Port 3

(Y) is '1'

### **Error Codes:**

E1 - Invalid radio port

(System wide errors are listed in front of the manual)

### **Example 1:**

I want the remote base assigned to port 2 with the remote prefix being a '1'

```
105 2 1 D or unkey
```

### **Response:**

"Remote is on <Port> with input <Prefix>"

## ***106: HF Mode Enable***

This command enables the HF remote base mode. This mode re-defines the DTMF keyboard into a quick HF remote access pad. When this mode is enabled, only HF commands can be entered. In order to execute any system wide commands the user must get-out of the HF mode.

<106>

### **Parameters:**

There are no parameters for this command

### **Defaults:**

HF mode is disabled

### **Notes:**

- Once HF mode is enabled the calling ports DTMF data is re-defined for HF operation

### **Error Codes:**

(System wide errors are listed in front of the manual)

### **Example 1:**

I want to enable HF mode

106 D or unkey

### **Response:**

"Remote Base On"

## *HF Remote Base Keypad*

### Keypad Definition

<b>1</b> Remote in <b>receive only</b> mode or Select <b>HF Mode #</b>	<b>2</b> Remote in <b>receive and transmit on</b> mode	<b>3</b> <b>Receive and transmit off.</b> Cancels HF mode	<b>A</b> Bump <b>Up</b> Remote  20HZ
<b>4</b> Bump <b>Down</b> Remote 100HZ or Execute an External Command ### (000..245)	<b>5</b> <b>Recall Memory</b> Channel ## 00..99 or Select <b>VFO A</b>	<b>6</b> Bump <b>Up</b> Remote  100HZ	<b>B</b> Bump <b>Down</b> Remote  20HZ
<b>7</b> Bump <b>Down</b> Remote 500 HZ or <b>Start Scan #</b>	<b>8</b> <b>Recall Frequency</b> of current VFO or <b>Select Offset</b>	<b>9</b> Bump <b>Up</b> Remote  500HZ	<b>C</b> Not Defined
<b>*</b> Frequency <Point> Key .	<b>0</b> <b>Write Memory</b> Channel ## or Select <b>VFO B</b>	<b>#</b> Force Execution Digit <b>Enter</b>	<b>D</b> Not Defined

### Special Definitions:

#### **HF Mode (See Keypad 1):**

HF Mode Number	Definition
1	Selects USB Mode
2	Selects LSB Mode
3	Selects AM Mode
4	Selects FM Mode

#### **Start Scan (See Keypad 7)**

Scan Number Entered	Scan Mode Requested
1	Scan Down Slow (20HZ Steps)
3	Scan Up Slow (20HZ Steps)
4	Scan Down Medium (100HZ Steps)
6	Scan Up Medium (100HZ Steps)
7	Scan Down Fast (500HZ Steps)
9	Scan Up Fast (500HZ Steps)



**HF Prefix:**

The HF prefix is a single digit that is configured with Command 105. This digit is always the first digit entered when any HF mode is executed. The reason for the prefix digit is to keep single digit entries from accidentally being entered.

Example: I am in HF mode and need to start the scan function for fast up scanning

Enter: 1 79 '#' or unkey                      Response: 'Scan 9'

Example: I am in HF mode and need to enter a frequency

Enter: 1 29\*600 '#' or unkey    Response: '2 9 point 6 0 0 0 0'

Example: I am in HF mode and need to recall memory 15

Enter: 1 515 '#' or unkey                      Response: 'Look-up 15'

In all these example the format for data entry was:

<HF Prefix> <Command> <Addition Data if Needed> <# or unkey>

**HF Frequency Entry:**

The frequency is entered immediately following the HF prefix. There is no command to tell the controller to take frequency, simply no command means frequency. The controller will take frequency input from 1 mhz (1\*00000) up to 999.99999 mhz (999\*99999).

**Typical HF remote base session:**

HF Prefix is '1'

- 1) 106 D or unkey ; Enable HF remote mode
- 2) 1 29\*68 # or unkey ; Move the HF remote to 29.680 mhz, VFO 'A'
- 3) 1 0 # or unkey ; Select VFO 'B'
- 4) 1 29\*58 # or unkey ; Move the HF remote to 29.580 mhz, VFO 'B'
- 5) 1 5 # or unkey ; Select VFO 'A'
- 6) 1 8 1 # or unkey ; Select Split (Repeater Mode)
- 7) 1 2 # or unkey ; Go into transmit and receive mode
- .
- .
- .
- 1 3 # or unkey ; Cancel HF mode after communications are complete

## ***107: HF Mode Disable***

This mode turns off the HF remote. The only real use for this command is giving other ports the ability to cancel the HF remote on the port that is currently using the remote functions. Because the command <HF Prefix> <3> cancels the remote function on the port that is using the remote, this command is for control only.

<107>

**Parameters:**

There are no parameters for this command

**Defaults:**

There are no defaults for this command

**Error Codes:**

(System wide errors are listed in front of the manual)

**Example 1:**

The user on port 1 did not cancel the HF remote. I can not reach port 1 but do have access to port 2. I need to cancel the remote function so control is returned to normal.

107 D or unkey

**Response:**

"Remote Off"

## ***108:Enter Icom's HF Radio Address or Kenwood's radio type***

This command is required when using ICOM HF radios. Because the Icom radios can co-exist on a common serial bus (CI-V) a radio address is needed to select what radio gets the serial data. The list below shows the radios address table.

If a Kenwood series radio is used this command selects what type of radio your remote is. The default radio is the TS-450 and later models. For earlier radios see the table below for the correct formatting.

<108> xx

### **Parameters:**

XX is the radios address. This number must be between 00..52

### **Defaults:**

Address (XX) set to 00. (Can not find your address?? Consult you radio manual)

Radio Address	Radio Type	Radio Address	Radio Type
00	Kenwood	TS-450 and	Later radios
01	Kenwood	TS-940	Only radio
02	Kenwood	TS-440 and	Earlier radios
04	IC-735	34	IC-471 A/E/H
08	IC-R7000	36	IC-1271 A/E
16	IC-275 A/E/H	38	IC-781
18	IC-375 A	40	IC-725
20	IC-475 A/E/H	42	IC-R9000
22	IC-575 A/H	44	IC-765
24	IC-1275 A/E	46	IC-970 A/E/H
26	IC-R71 A/E/D	47	IC-706
28	IC-751 A	48	IC-726
30	IC-761	50	IC-R72
32	IC-271 A/E/H	52	IC-R7100

**Error Codes:**

E1 - Invalid remote address

(System wide errors are listed in front of the manual)

**Example 1:**

I want to set my radios address for the Icom IC-725

108 40 D or unkey

**Response:**

"Radio Is <Radio Address>"

**Example 2:**

I have a Kenwood TS-440 radio and need to select the correct mode for my radio

108 02 D or unkey

**Response:**

"Radio Is <Radio Address>"

**Special Note:**

If you are going to run an HF remote base you need to make sure the controller supports your radio type. See the top label of the system EPROM and see what radio type is specified on the ROM. If the ROM does not match your radio type then you must get a different ROM for Link Communications, Inc.

## ***109: Command Line Control of the HF Routines***

This command has the same function as Command 106 except you do not need to be in HF mode to access the HF commands. This command allows macros and scheduler events to access, set-up and function the remote's features. The format of this command is the same as Command 106.

```
<109> x y..y
```

### **Parameters:**

X is the HF prefix

Y..Y are the functions that can be accessed using Command 106

### **Defaults:**

There are no defaults for this command

### **Notes:**

- Refer to Command 106 for the keystroke definitions.
- The 'point' key (\*) in Command 106 is redefined to the 'pound' (#) key. This change is needed so the 'point' in the frequency will not interfere with other controller functions.

### **Error Codes:**

(System wide errors are listed in front of the manual)

### **Example 1:**

I want to set the remotes frequency to 14.250. My HF prefix is '1'

```
109 1 14#250 D or unkey
```

### **Response:**

Refer to Command 106

## *Chapter 12 Examples*

## ***Example 12-1: I need a macro to set-up the HF remote up***

The controller supports the user to enter and control the HF remote base system without actually entering into HF mode. Command 109 is provided as the command line entry of commands into the HF mode executer.

This example was tested on an Icom IC-725 interface. Other radio types may vary in operation and set-up.

- I want to set the frequency to 29.680 on VFO A, this will be my receive frequency
- I want to set the frequency to 29.580 on VFO B, this will be my transmit frequency
- I want to enable split mode

For the example the 'HF Prefix' is the default '1'. We will use macro 20 to store this example.

- 1) Clear the HF macro  
- 165 20 D or unkey ; Clear macro 20
- 2) Send the message  
- 168 20 045 020 009 006 008 361 D or unkey ; '29 point 5 8 repeater'
- 3) Cancel responses  
- 168 20 169 D or unkey ; Cancel Responses
- 4) First frequency  
- 168 20 109 1 29#68 D or unkey ; Frequency at 29.680
- 5) Select VFO 'B'  
- 168 20 109 1 0 D or unkey ; Select VFO 'B'
- 6) Second Frequency  
- 168 20 109 1 29#58 D or unkey ; Frequency at 29.580
- 7) Select VFO 'A'  
- 168 20 109 1 5 D or unkey ; Select VFO 'A'
- 8) Turn on Split Mode  
- 168 20 109 1 8 1 ; Enables Split Mode

This macro sets-up the remote to operate on 29.680/29.580 in repeater mode.

## *HF Radio Interfacing*

The RLC-2 supports connection of your HF's serial port to the RLC-2's serial port. The RLC-2 requires RS-232 levels, but your radio usually requires TTL levels. This requires an external RS-232--TTL level translator. With this external interface the RLC-2 is happy to see the correct levels and your radio is happy to see the TTL levels. Do not hook your HF radio directly to the RLC-2 without a level translator.

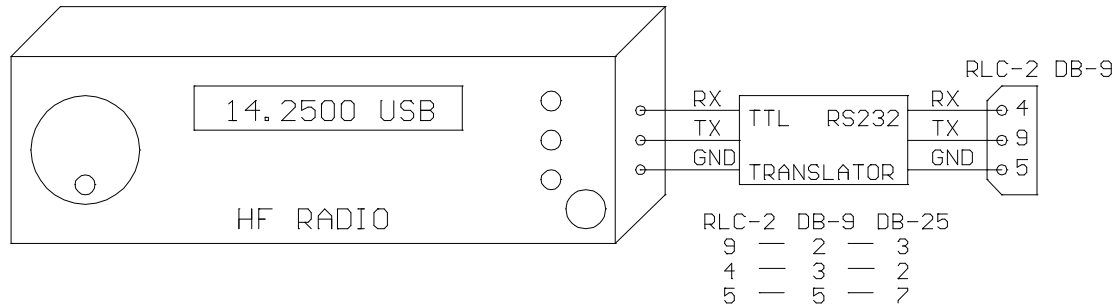



## ***Chapter 13: Pre-Access Code Set-up***

This chapter deals with the pre-access code system supported on the controller. This code system allows the system to be configured for 1,2,3 code access from the links, and a 'D' access from the repeater ports. This coding is common for large linking systems.

## *120: Assign the 3 Ports Link Prefixes*

This command assigns the link port prefix codes. These prefix codes are only used when the controller is in pre-access mode. The repeater prefix code is always 'D'

```
<120> x yyy
```

### **Parameters:**

X is the port to assign the prefix digits.

Pre-Access Number	Port Name
1	Port 1
2	Port 2
3	Port 3

YYY is the new prefix code. This code can be any of the DTMF digits except the 'Forced Execution Digit'.

### **Defaults:**

Port 1 defaults to '#97'

Port 2 defaults to '#98'

Port 3 defaults to '#99'

### **Notes:**

- Refer to the timer commands 050,051,052 to control the pre-access timer and dial tone generation length.

### **Error Codes:**

E1 - Invalid radio port

(System wide errors are listed in front of the manual)

### **Example 1:**

I want to change port 1's code to 93#

```
120 1 93# D or unkey
```

### **Response:**

"<Port> Code is <New Prefix Code>"

## *121: Configure Pre-Access on a Port*

This command configured how pre-access works on each port. This command controls dial tone generation requirements and the dial tone response frequency for a port.

```
<121> w x yyyy zzzz
```

### **Parameters:**

W is the port number. This number must range from 1..3

X is the dial tone response control

0 - No dial tone generated

1 - Dial tone generated on valid pre-access code receipt

YYYY is the first tone of the dial tone response

ZZZZ is the second tone of the dial tone response

### **Defaults:**

All ports dial tone generation is disabled (off)

### **Error Codes:**

E1 - Invalid port. Number must range between 1..3

E2 - Invalid mode. Mode must be either a 0,1

(System wide errors are listed in front of the manual)

### **Example 1:**

I want my port 3 to generate a dial tone when selected. This means the dial tone will begin when the correct pre-access code is received.

```
121 3 1 2856 2271 D or unkey
```

### **Response:**

"Code Set Up Radio <Port> Dial <ON\OFF>Frequency <Tone1> and <Tone2>"

## ***122: Enable/Disable Pre-Access on a Port***

This command enables or disabled pre-access on a specific port. When pre-access is enabled the port requires the pre-access code be received before any commands can be executed.

```
<122> x y
```

### **Parameters:**

X is the port number. This number must range from 1..3

Y is the control variable

0 - Disables pre-access

1 - Enables pre-access

### **Defaults:**

All ports pre-access default off

### **Notes:**

- When a repeater is in pre-access the code for access is 'D' not the pre-access code. This code only applies when the port is in a link mode. Repeaters will not generate the dial tone.

### **Error Codes:**

E1 - Invalid port. Number must range between 1..3

E2 - Invalid mode. Mode must be either a 0,1

(System wide errors are listed in front of the manual)

### **Example 1:**

I need to enable pre-access on port 2

```
122 2 1 D or unkey
```

### **Response:**

"Code Input <ON/OFF>"

## ***123: Pre-Access Configure for the Stop Access Mode***

This command configured how the pre-access condition is controlled. In order to stop access into the controller certain link groups use different conditions. We have incorporated 3 into the controller.

```
<123> x y z
```

### **Parameters:**

X is the stop access condition when a command is executed correctly

0 - Disables this feature

1 - Enables this feature

Y is the stop access condition when a command is executed and an error is received

0 - Disables this feature

1 - Enables this feature

Z is the stop access condition when the commanding receiver drops

0 - Disables this feature

1 - Enables this feature

### **Defaults:**

X,Y,Z default to disabled

### **Error Codes:**

E1 - Invalid port. Number must be from 1..3

(System wide errors are listed in front of the manual)

### **Example 1:**

I want to enable command execution to stop access.

```
123 100 D or unkey
```

### **Response:**

"Code set as <X Variable> <Y Variable> <Z Variable>"

## *Chapter 13 Examples*

### ***Example 13-1: Configuring ports for Pre-access***

This example goes through the steps needed for setting up a link port for pre-access. The link will request dial tone upon proper site prefix reception.

1) Define Port 2,3 site prefix as #34

- 120 2 #34 D or unkey ; Assign port 2 access code as #34

- 120 3 #34 D or unkey ; Assign port 3 access code as #34

Where (2,3) are the ports defining the pre-access code, (#34) is the site prefix code.

2) Enable dial tone generation for ports 2,3

- 121 2 1 2856 2271 D or unkey ; Enable dial tone on port 2

- 121 3 1 2856 2271 D or unkey ; Enable dial tone on port 3

3) Enable pre-access on port 1 which is the repeater port

- 122 1 1 D or unkey ; Enable port 1 repeater pre-access on

4) Enable pre-access on port 2. DTMF for this command is coming from port 1

- \* 122 2 1 D or unkey ; Enable port 2 pre-access on

Where (\*) is port 1's repeater prefix code, (2) is the port number, (1) enables pre-access.

5) Enable pre-access on port 3. DTMF for this command is coming from port 2

- #34 <Dial Tone> 122 3 1 D or unkey ; Enable port 3 pre-access on

Where (#34) is port 2's link prefix code. Once the prefix code is received (#34) the link will send the dial tone. The user must then enter the command (122) followed by the additional data (3 1).

Now data that is entered from the repeater port must begin with the '\*' prefix followed by the command and data if any. Once the command is entered and executed the prefix situation may either stop, or continue to be available for user access. See Command 123 for stop access configuration. The controller defaults with the pre-access stop conditions all off. Access will stop when the ports access timer expires.

## ***Example 13-2: Pre-Access Events, Configurations and Uses***

Every pre-accessed system is different in its functions and operations. Because of these differences 6 events have been added to the controllers event table (See Command 064) to allow custom configuration of the accessed system. These events can contain custom port-port configurations to match your systems needs

Example #1: I need to disconnect the links from the repeater (Port 1) when port 1 accesses the system and re-connect the links when the repeater un-accesses the system.

- We will use macro #10 for the disconnect macro (Command 181)
  - 1) 165 10 D or unkey or <Enter> ; Delete macro #10
  - 2) 168 10 169 D or unkey or <Enter> ; Cancel all responses for this macro
  - 3) 168 10 002 12 D or unkey or <Enter> ; Disconnect Port 1 from Port 2
  - 4) 168 10 002 13 D or unkey or <Enter> ; Disconnect Port 1 from Port 3
- We will use macro #11 for the connect macro (Command 182)
  - 5) 165 11 D or unkey or <Enter> ; Delete macro #11
  - 6) 168 11 169 D or unkey or <Enter> ; Cancel all responses for this macro
  - 7) 168 11 000 12 D or unkey or <Enter> ; Connect Port 1 to Port 2
  - 8) 168 11 000 13 D or unkey or <Enter> ; Connect Port 1 to Port 3
- We need to assign events
  - 9) 064 044 2 181 01 D or unkey or <Enter>; Assign Command 181 when port 1 starts access
  - 10) 064 047 2 182 01 D or unkey or <Enter>; Assign Command 182 when port 1 stops access

When Port 1 enters a correct pre-access code the start access event for port 1 (044) will request macro 181. This macro disconnects ports 2,3 from the repeater port. When the access for port 1 stops for port 1 (047) macro 182 will be requested. This will re-connect port 1 to port 2,3.



## ***Chapter 14: The Autopatch System***

This chapter deals with the systems autopatch option. The system defaults enabling 7 digit dialing, 911 dialing and all autodial slots.

## ***119: Reverse Autopatch Call-Sign Beacons Request***

This command allows the user to set-up a cycle beacons for a requested person. When Command 147 is executed, the controller resets the beacons counter to the user programmed value and stores the call-sign of the person requested. Using a user timer or a drop-out message slot, the user can have the person paged 'nn' number of times. The beacons is canceled when:

- Beacon counter reaches zero
- Autopatch is placed back on-hook by either the user or the controllers timer
- User answers the page using Command 125

When Command 119 is called without any additional data the call-sign of the person is requested is the beacon counter has not reached zero yet.

<119>

When Command 119 is called with 2 digits of additional data, the call-sign beacon counter is programmed.

<119> bb

### **Parameters:**

BB is the beacon counter value. Number ranges from 01..99

### **Defaults:**

The call-sign beacon counter is 05

### **Error Codes:**

(System wide errors are listed in front of the manual)

### **Notes:**

- Refer to Command 135 to program call-sign mode
- Refer to Command 147 to request call-sign page
- Refer to Command 064 event 108 for call-sign sequence request event

**Example 1:**

I want to set-up a paging sequence that request a user 5 times.

- |                                  |  |
|----------------------------------|--|
| 1) 023 1                         | ; TIMED EXECUTION ENABLED                      |
| 2) 004 1234                      | ; SET FIXED PASSWORD TO 1234                   |
| 3) 126 2 02 04 2271 2082         | ; REVERSE PATCH MODE 2, 2 RINGS TO ANSWER      |
| 4) 137 1                         | ; CALL SIGN MODE ENABLED                       |
| 5) 132 001 4827515               | ; AUTODIAL SLOT 001 SET TO DIAL: 482-7515      |
| 6) 135 01 09 040 035 007 035 052 | ; CALL SIGN KF7FW ROUTED TO PATCH AND PORT 1   |
| 7) 119 05                        | ; BEACON COUNTER SET TO 5 TIMES                |
| 8) 168 01 169                    | ; MACRO 01 SILENT EXECUTION                    |
| 9) 168 01 066 1                  | ; RESTART USER TIMER 1, BEACON CYCLE TIMER     |
| 10) 168 02 119                   | ; REQUEST 'CALL FOR' CYCLE MESSAGE ROUTINE     |
| 11) 168 02 169                   | ; MACRO 02 SILENT EXECUTION FROM NOW ON        |
| 12) 168 02 066 1                 | ; RESTART USER TIMER 1, BEACON CYCLE TIMER     |
| 13) 064 108 2 171 09             | ; ASSIGN CALL SIGN BEACON EVENT TO MACRO 01    |
| 14) 064 089 2 172 09             | ; USER TIMER 1 EVENT RESTARTS BEACON CYCLE     |
| 15) 052 35 015                   | ; USER TIMER 1 (CYCLE TIMER) SET TO 15 SECONDS |

CALLED CONTROLLER AND EXECUTE COMMAND <147> 01

VOICE RESPONSE: "CALL FOR 'KF7FW'"

- 15 SECONDS LATER: VOICE RESPONSE: CALL FOR 'KF7FW'
- 15 SECONDS LATER: VOICE RESPONSE: CALL FOR 'KF7FW'
- 15 SECONDS LATER: VOICE RESPONSE: CALL FOR 'KF7FW'
- 15 SECONDS LATER: VOICE RESPONSE: CALL FOR 'KF7FW'
- 15 SECONDS LATER: VOICE RESPONSE: CALL FOR 'KF7FW'

NO RESPONSE AFTER 5 CYCLES CANCELS 'CALL FOR' REQUEST

CONDITIONS:

- COMMAND 125 (REVERSE PATCH ANSWER) CANCELS THE CYCLE AND/OR...
- PATCH HUNG-UP WITH COMMAND 146 OR TIMED-OUT CANCELS THE CYCLE

## ***125: Reverse Autopatch Answer on the Repeater***

This command answers the reverse autopatch when it is ringing over the air. In order for this command to function first the reverse patch must be enabled, and there must be rings from the reverse patch in the controller.

<125>

### **Parameters:**

There are no parameters for this command

### **Defaults:**

The reverse patch is disabled

### **Error Codes:**

(System wide errors are listed in front of the manual)

### **Notes:**

- Refer to Command 007 to configure where the autopatch rings. The audio routing variable that is programmed for the autopatch determines where the autopatch rings when the reverse patch is in mode 1.

### **Example 1:**

The reverse patch is ringing over the air and I need to answer it.

125 D or unkey

### **Response:**

There is no response for this command

## 126: Configure the Reverse Autopatch

This command allows the configuration of the reverse autopatch system. Mode 1 configured the reverse autopatch to directly ring over the air. Mode 2 configured the reverse autopatch to answer after (RR) number of rings. At this point the users can then execute controller commands.

```
<126> m rr hh xxxx yyyy
```

### Parameters:

M is the mode the reverse patch is in

Mode	Description
0	Reverse patch disabled
1	Over-the-air ringing enabled
2	Auto-answer enabled

**RR** is the ring mask counter. The phone must ring (RR) times before the controller will cause an over the airing.

**HH** is the maximum allowed rings. Once the (RR) ring counter is reached the controller will allow ringing over the air until the (HH) ring counter is reached. At this point ringing over the air will stop. This keeps a ringing phone from locking up the repeater ringing.

**XXXX** is the tone counts for the over-the-air ring tone frequency 1 (See Appendix B)

**YYYY** is the tone counts for the over-the-air ring tone frequency 2 (See Appendix B)

### Defaults:

The reverse autopatch is disabled (M) is 0

(RR) is 04 rings for the in counter

(HH) is 08 rings for the maximum counter

XXXX is 2271 (440 HZ)

YYYY is 2082 (480 HZ)

### Error Codes:

E1 - Invalid reverse patch mode

(System wide errors are listed in front of the manual)

### Example 1:

I want to configure the reverse patch mode for over-the-air ringing, ring counter of 02, max ring counter of 20, 440 and 480 HZ ring tone.

```
126 1 02 20 2271 2082 D or unkey
```

### Response:

"Autopatch In Is <Mode>and<In Ring>and<Max Ring>and<Tone 1>and<Tone 2>"

## *Mode 1 Definitions*

When the reverse patch is in this configuration the phone is never answered automatically by the controller. This mode causes a ringing sequence to be send out the configured ports.

Ringing configuration:

- Number of rings before over-the-air ringing Command 126
- Number of rings allowed before canceling over-the-air ringing Command 126
- Ring port routing (Controls where the ringing is sent) Command 007
- Ringing tones (Controls the user ring tone setup) Command 126

## *Mode 2 Definitions*

When the reverse patch is in this configuration the phone is answered automatically by the controller after the ring counter is reached. The ring counter defaults to 4 rings. When the phone has been answered by the controller, the user has certain time provisions that must be met. If these provisions are not met the controller will hand up the phone. This mode is to control programming and personal call sign paging over the configured radio ports.

Configurations:

- Number of rings before over-the-air ringing Command 126
- Over-the-air port routing (Controls where the audio/PTT are sent) Command 007
- Definition of Call sign usage (Top 100 dial slots used for call signs) Command 137
- Programs Call sign data (Used when reverse patch user calling) Command 135

Timers:

- From autopatch answer to valid executed Command 052 slot 50
- From executed command to executed Command 052 slot 51
- Control operator execution Command 052 slot 52

In this mode the user must correctly execute Command 005, the user log-on. After correct execution of the un-lock command the control operator timer is started.

## 127: Configure the Forward Autopatch

This command configured the forward autopatch system. This command only configured patch operation. Dialing tables are configured later.

```
<127> a b c d e
```

### Parameters:

A is Full/Half duplex control

- 0 is half duplex
- 1 is full duplex

B controls the readback in direct dial mode

- 0 disables readback of the number
- 1 enables readback of the number

C controls the readback in memory dial mode

- 0 disables readback of the memory dial information
- 1 enables readback of the memory dial information

D controls the readback type in memory dial mode

- 0 read back of memory dial slot number
- 1 read back of call sign contents if configured using Command 137

E control seven digit dialing with out going through the dialing allow table

- 0 disables the 7 digit dialing allow bypass
- 1 enables 7 digit dialing allow bypass

### Defaults:

- (A) is half duplex
- (BCD) are enabled
- (E) allows 7 digit dialing

### Error Codes:

- E1 - Invalid mode. Data must be either a (1) or a (0)  
(System wide errors are listed in front of the manual)

### Example 1:

I want to enable all readback styles on the forward patch, but keep the half duplex mode.

```
127 01110 D or unkey
```

### Response:

"Autopatch Out Is <A><B><C><D><E>"

## ***128: Program Dialing Number Allow Table***

This command allows the programming of the dialing allow table. This is the sole table for controlling long distance and prefix dialing control. This table supports 45 number sequences of 7 digits per entry. If there are no numbers programmed into this table, the forward autopatch that does dialing checking (Command 143) will not function. Only number styles found in this table will be allowed to dial.

```
<128> ss yyyyyyy
```

### **Parameters:**

SS is the allow tables slot number. This number ranges from 01..45

YYYYYYY is the 7 digit allow number

The allow table allows 'wildcards' in the entry sequence. The 'wildcard' digit is the '#' digit. When the controller compares user entered digits and comes upon a '#' in the table, that digit is a don't care.

Examples: (All examples will store in slot 01)

#### **1) Allow all 1-800 numbers**

The entry would look like: <128> 01 1800 ### D or unkey. This sequence tells the autopatch to allow the digits '1800' and to ignore the 3 digit prefix.

#### **2) Allow local 7 digit dialing in prefix area 480..489**

The entry would look like: <128> 01 48##### D or unkey. This sequence tells the autopatch to allow the digits all digits that begin 48 and ignore the rest of the number.

#### **3) Allow local 7 digit dialing in prefix are 482 only**

The entry would look like: <128> 01 482##### D or unkey. This sequence tells the autopatch to allow the digits all digits that begin 482 and ignore the rest of the number.

### **Defaults:**

All allow slots are off

### **Error Codes:**

E1 - Invalid dialer slot. Number must be between 01..45

(System wide errors are listed in front of the manual)

### **Example 1:**

I want to allow 1-800 numbers and store the result in slot 43

```
128 43 1800### D or unkey
```

### **Response:**

"<Slot> is <Number>"



## ***129: Recall Dialing Number Allow Table***

This command recalls the results of the dialing table programmed in Command 128.

```
<129> ss
```

**Parameters:**

SS is the allow tables slot number. This number ranges from 01..45

**Defaults:**

All allow slots are off

**Error Codes:**

E1 - Invalid dialer slot. Number must be between 01..45  
(System wide errors are listed in front of the manual)

**Example 1:**

I want to check what is in allow slot 43.

```
129 43 D or unkey
```

**Response:**

"<Slot> is <ON/OFF> Number is <Result>"

## ***130: Enable/Disable Number Allow Table Entry***

This command enables/disables an allow table entry.

```
<130> ss y
```

### **Parameters:**

SS is the allow tables slot number. This number ranges from 01..45

Y is the control variable

0 - disables allow table entry

1 - enables allow table entry

### **Defaults:**

All allow slots are off

### **Error Codes:**

E1 - Invalid dialer slot. Number must be between 01..45

(System wide errors are listed in front of the manual)

### **Example 1:**

I want to disable allow slot 43.

```
130 43 0 D or unkey
```

### **Response:**

"<Slot> is <ON/OFF>"

## ***132: Program Memory Dial***

This command programs the memory dial tables. This table holds either 100 or 200 16 digit phone numbers. The phone numbers bypass the pre-dial data thus allowing custom programming sequences. Memory dial numbers are not checked for long distance and are dialed without controller interference.

```
<132> sss y..y
```

### **Parameters:**

SSS is the memory dial slot number. This number ranges between 000..199 and 911 if all 200 numbers are enabled without callsigns. If the autopatch memory dial is configured to contain callsigns, then this number ranges between 000..099 and 911.

Y..Y is the phone number to be dialed

### **Defaults:**

All memory dial slots are disabled

### **Notes:**

- Refer to Command 137 for memory dial selection types

### **Error Codes:**

E1 - Too much or too little data

E2 - Invalid dialer slot

(System wide errors are listed in front of the manual)

### **Example 1:**

I want to set-up my 911 emergency dial slot to contain '911'

```
132 911 911 D or unkey
```

### **Response:**

"<Slot> is <Number>"

## ***133: Recall Memory Dial Slot***

This command recalls a memory dial slots contents. This table holds either 100 or 200 16 digit phone numbers. The phone numbers bypass the pre-dial data thus allowing custom programming sequences. Memory dial numbers are not checked for long distance and are dialed without controller interference.

```
<133> sss
```

### **Parameters:**

SSS is the memory dial slot number. This number ranges between 000..199 and 911 if all 200 numbers are enabled without callsigns. If the autopatch memory dial is configured to contain callsigns, then this number ranges between 000..099 and 911.

### **Defaults:**

All memory dial slots are disabled

### **Notes:**

- Refer to Command 137 for memory dial selection types

### **Error Codes:**

E1 - Invalid dialer slot

(System wide errors are listed in front of the manual)

### **Example 1:**

I check what my 911 memory dial slot contains

```
133 911 D or unkey
```

### **Response:**

"<Slot> is <ON/OFF> Number is <Number>"

## ***134: Enable/Disable Dialing Slot***

This command enables/disables a memory dialing slot. When a slot is disabled, the contents are still kept, the slot just can not be dialed.

```
<134> sss x
```

### **Parameters:**

SSS is the memory dial slot number. This number ranges between 000..199 and 911 if all 200 numbers are enabled without callsigns. If the autopatch memory dial is configured to contain callsigns, then this number ranges between 000..099 and 911.

X is the control variable

- 0 - Disables memory dial slot
- 1 - Enables memory dial slot

### **Defaults:**

All memory dial slots are disabled

### **Notes:**

- Refer to Command 137 for memory dial selection types

### **Error Codes:**

E1 - Invalid dialer slot

(System wide errors are listed in front of the manual)

### **Example 1:**

I want to disable my 911 memory dial slot because of misuse

```
134 911 0 D or unkey
```

### **Response:**

"<Slot> is <ON/OFF>"

## 135: Program Call Sign Assignment

This command programs the call sign portion of the memory dial slots. In order to have call signs assigned, the user must configure Command 137. When configured the top 100 memory dial slots are erased and configured for call sign readback.

```
<135> ss rr y..y
```

### Parameters:

SS is the memory dial slot number. This number ranges between 00..99

RR is the audio routing variable. This number ranges between 00..31 and is only used in the reverse autopatch mode 2 when paging a user. (See command 147)

Y..Y is the call sign data. The word data must be between 000..255. This includes all the alphabet and some other controller words.

### Defaults:

Call sign mode is disabled

### Notes:

- The user must execute Command 137 to enable/disable call sign mode. When this command is executed, the controller erases the top 100 memory dial slots, or call signs, and re-configured the slots for the selected option. Care must be taken when executing Command 137.
- See Commands 147 to access call-sign recall
- See Command 119 to operate call-sign beaconing

### Error Codes:

E1 - Call sign mode not enabled

E2 - Too much data entered. Up to 8 words can be programmed per call sign position

E3 - Invalid call sign slot. The call sign numbers are the same as the memory slot number. This number ranges from 00..99

E4 - Invalid word number. The words must be between 000..255

(System wide errors are listed in front of the manual)

### Example 1:

I want assign the call sign "KF7FW Home" to memory slot 01, who monitors port 1

```
135 01 01 040 035 007 035 052 215 D or unkey
```

### Response:

"Call <Slot> is <Entered Call Sign> Route is <Route>"

## ***136: Recall Call Sign Assignment***

This command recalls the contents of a call sign slot. If the response only speaks "Call Is" then the call sign slot is not programmed.

```
<136> ss
```

### **Parameters:**

SS is the call sign slot. This number must range between 00..99

### **Defaults:**

Call sign mode is disabled

### **Notes:**

- The user must execute Command 137 to enable/disable call sign mode. When this command is executed, the controller erases the top 100 memory dial slots, or call signs, and re-configured the slots for the selected option. Care must be taken when executing Command 137.

### **Error Codes:**

E1 - Call sign mode not enabled

E2 - Invalid call sign slot. The call sign numbers are the same as the memory slot number. This number ranges from 00..99

(System wide errors are listed in front of the manual)

### **Example 1:**

I check what is assigned to memory slot 01

```
136 01 D or unkey
```

### **Response:**

"Call is <Entered Call Sign> Route <Response Route>"

## *137: Set Up Autodial Mode*

This command configured call sign mode. When this mode is enabled, the top 100 dialing slots are converted to call sign slots. When this mode is disabled, the top 100 dialing slots are converted for 100 more memory dial positions.

```
<137> x
```

### **Parameters:**

X is the control variable

0 - Disables call sign mode

1 - Enables call sign mode

### **Defaults:**

Call sign mode is disabled

### **Notes:**

- When executing this command, the user must take care when changing the configuration. By enable/disabling call sign mode, the controller erases the top 100 memory positions and configured the memory for either call signs or memory dial numbers. **All information will be erased in the top 100 positions when executed.**

### **Error Codes:**

E1 - Invalid mode. This mode must be either a 0 or a 1.

(System wide errors are listed in front of the manual)

### **Example 1:**

I want to set-up the memory in the autopatch to support call signs. I understand it will erase any information that is currently stored in the upper 100 block of numbers.

```
137 1 D or unkey
```

### **Response:**

"Autopatch Call Route <ON/OFF>"



## ***138: Program a Nuisance Number Slot***

This command functions in the opposite of the allow tables operation. When a number is received and passes the allow table it must also pass through the nuisance table without a number match. If a match occurs, the number is discarded and dialing will not take place. The nuisance table supports the wildcard digit '#' but also supports the complete 11 digit number. This allows users the ability to lock-out numbers and near matches.

```
<138> ss yyyyyyyyyyy
```

### **Parameters:**

SS is the nuisance slot. This number must be between 01..10

YYYYYYYYYYYY is the 11 digit nuisance number

The allow table allows 'wildcards' in the entry sequence. The 'wildcard' digit is the '#' digit. When the controller compares user entered digits and comes upon a '#' in the table, that digit is a don't care.

Examples: (All examples will store in slot 01)

1) Do not allow the dialing of my home number 1-406-482-7515

The entry would look like: <138> 01 14064827515 D or unkey. This sequence tells the autopatch to dis-allow the number '1-406-482-7515'.

2) I allowed the number block 480..489 in Command 128. I need to disallow 483.

The entry would look like: <138> 01 483##### D or unkey. This sequence tells the autopatch to dis-allow all digits that begin 483 and ignore the rest of the number.

### **Defaults:**

All allow slots are off

### **Error Codes:**

E1 - Invalid slot. This number must be between 01..10

(System wide errors are listed in front of the manual)

### **Response:**

"<Slot> is <Number>"

## ***139: Recall a Nuisance Number Slot***

This command recalls a nuisance slot.

```
<139> ss
```

### **Parameters:**

SS is the allow tables slot number. This number ranges from 01..10

### **Defaults:**

All dis-allow slots are off

### **Error Codes:**

E1 - Invalid dialer slot. Number must be between 01..10

(System wide errors are listed in front of the manual)

### **Example 1:**

I want to check what is in dis-allow slot 01.

```
139 01 D or unkey
```

### **Response:**

"<Slot> is <ON/OFF> Number is <Result>"

## ***140: Enable/Disable a Nuisance Slot***

This command enables/disables an allow table entry.

```
<140> ss y
```

### **Parameters:**

SS is the dis-allow tables slot number. This number ranges from 01..10

Y is the control variable

0 - disables allow table entry

1 - enables allow table entry

### **Defaults:**

All dis-allow slots are off

### **Error Codes:**

E1 - Invalid dialer slot. Number must be between 01..10

(System wide errors are listed in front of the manual)

### **Example 1:**

I want to disable allow slot 01.

```
140 10 0 D or unkey
```

### **Response:**

"<Slot> is <ON/OFF>"

## ***141: Programs Pre-Dial Digits and Controls Dialing***

This command programs the system pre-dial digits. These pre-dial digits are used when call block is needed and/or a PBX outside line is requested. The controller can dial up to 5 pre-dial digits. If a special delay is needed in the dialing string the DTMF digit 'B' can be inserted and no digit will be dialed. The controller already inserts 3 'B' digit delays between pre-dial dialing and the number dialing. Memory dialed numbers do not use the pre-dial routines.

```
<141> y..y
```

### **Parameters:**

Y..Y are the pre-dial digits needed. You can enter up to 5 pre-dial digits.

If you do not enter any 'Y' digits, the pre-dial data will be erased thus canceling the pre-dial feature.

### **Defaults:**

There are no pre-dial data

### **Notes:**

- Caller ID's can be suppressed by inserting a predial sequence of 'D67'. In order to enter this sequence the user must do the following.
  - 1) Change the Forced Execution Digit to a '#'
  - 2) Execute Command 141 with data D67. <141>D67 unkey or '#'
  - 3) Change the Forced Execution Digit back to a 'D'
  - 4) Now when calls are made, the sequence D67 will be sent first, followed by the number

### **Error Codes:**

E1 - Too much data. This command can take from 1..5 digits of additional data  
(System wide errors are listed in front of the manual)

### **Example 1:**

I want a pre-dial of 9 to get an outside PBX line

```
141 9 D or unkey
```

### **Response:**

"<Pre-Dial Data>" or "Autopatch Dial Clear"

## ***142: Recalls Pre-Dial Digits***

This command recalls the pre-dial digits programmed in Command 141.

<142>

### **Parameters:**

There are no parameters for this command

### **Defaults:**

There are no pre-dial data

### **Error Codes:**

(System wide errors are listed in front of the manual)

### **Example 1:**

I need to see if there are pre-dial digits programmed

142 D or unkey

### **Response:**

"<Pre-Dial Data>" or "Autopatch Dial Clear"

## 143: Patch On-Line with Dialing Table Checking

This command dials an autopatch number with allow and nuisance table checking. From this command all autopatch dialing takes place.

Memory dial recall 0..9

<143> x

Memory dial recall 00..99

<143> xx

Memory dial recall 000..199 and/or 911

External dialing 200..999

<143> xxx

External dialing

<143> xxx..x

### Parameters:

X..X are the digits to cause dialing. These digits can only be 0..9

### Defaults:

Command 143 defaults to '\*' for the command name

### Error Codes:

E1 - Number failed the allow table. See Command 128

E2 - Number failed to pass the nuisance number test. See Command 138

E3 - Invalid dialed memory number when call-sign mode active. This number must be between 00..99 when dialing a memory dialed number and in call sign mode.

E4 - Memory dialed number requested is either not programmed or enabled.

(System wide errors are listed in front of the manual)

### Example 1:

I want to dial the number 1-800-555-1212. I have allowed all '800 number to dial in Command 128.

\* 18005551212 D or unkey

### Response:

"Autopatch <Number if enabled (See Command 127 for readback set-up)>"

If the autopatch is being used on another port the response is: "Autopatch is Busy"

## 144: Patch On-Line without Dialing Table Checking

This command dials an autopatch number with-out allow and nuisance table checking. From this command all autopatch dialing takes place.

Memory dial recall 0..9

```
<144> x
```

Memory dial recall 00..99

```
<144> xx
```

Memory dial recall 000..199 and/or 911  
External dialing 200..999

```
<144> xxx
```

External dialing

```
<144> xxx..x
```

### Parameters:

X..X are the digits to cause dialing

### Defaults:

There are no defaults for this command

### Notes:

- This command should not be made available to normal users. This command opens the autopatch to non-supervised long distance dialing.

### Error Codes:

E3 - Invalid dialed memory number when call-sign mode active. This number must be between 00..99 when dialing a memory dialed number and in call sign mode.

E4 - Memory dialed number requested is either not programmed or enabled.

(System wide errors are listed in front of the manual)

### Example 1:

I want to dial the number 1-800-555-1212.

```
144 18005551212 D or unkey
```

### Response:

"Autopatch <Number if enabled (See Command 127 for readback set-up)>"

If the autopatch is being used on another port the response is: "Autopatch is Busy"

## ***145: Manual Patch On-Line***

This command manually takes the autopatch off-hook and presents dial tone to the calling port. No DTMF regeneration, allow or nuisance checks are functional in this command.

<145>

### **Parameters:**

There are no parameters for this command

### **Defaults:**

There are no defaults for this command

### **Notes:**

- This command should not be made available to normal users. This command opens the autopatch to non-supervised long distance dialing.

### **Error Codes:**

(System wide errors are listed in front of the manual)

### **Example 1:**

I need to adjust the autopatch. By taking the patch off-hook manually I can set-up the patch easier.

145 D or unkey

### **Response:**

No response is directly assigned to this command. See event table programming to customize a response.



## ***146: Hanging Up the Patch***

This command places the patch on-hook after either a forward patch or reverse patch session.

<146>

### **Parameters:**

There are no parameters for this command

### **Defaults:**

Command 146 defaults to '#' for the command name

### **Error Codes:**

(System wide errors are listed in front of the manual)

### **Example 1:**

I need to hang-up the patch

# D or unkey

### **Response:**

No response is directly assigned to this command. See event table programming to customize a response.

## ***147: Call Sign Request and Enter Programming Mode***

This command allows a user to request a call-sign be spoken over the selected port. This command is useful when reverse autopatch user paging is needed. By re-naming the call sign request command to a shorter command, the user can page users over-the-air by there dialing slot number. When this command is executed, event 108 is requested. This event is used to start the paging sequence.

```
<147> ss
```

### **Parameters:**

SS is the call sign slot number. This number must be between 00..99

### **Defaults:**

Call sign mode is disabled

### **Notes:**

- Refer to Commands 135,136,137 for call sign configurations
- Refer to Command 007 for autopatch audio routing programming. The autopatch variable sets were the reverse autopatches audio is routed.
- See Command 119 to allow call-sign beaconing
- Refer to Command 064 event 108 (Called when this command executed)

### **Error Codes:**

E1 - Invalid call sign slot

(System wide errors are listed in front of the manual)

### **Example 1:**

I need to page user 55

```
147 55 D or unkey
```

### **Response:**

"Call For <Call sign in slot SS>"

## ***148: Last Number Redial***

This command re-dials the last number that was dialed. If the number was busy, or no one answered, simply execute this command to re-dial that old entered number.

<148>

### **Parameters:**

There are no parameters for this command

### **Defaults:**

Command 148 defaults to '\*\*' for the command name

### **Error Codes:**

E1 - There is no number to redial

(System wide errors are listed in front of the manual)

### **Example 1:**

I want to redial the party I just tried to call

\*\* D or unkey

### **Response:**

"Repeat Dial"

## ***149: Reset Autopatch Time-Out Timer***

This command resets the autopatch reverse and forward time-out timers when executed. If you get the 30 second time-out timer message, and you want to continue the call, simply execute command 149 to reset the time-out timer for another calling length.

```
<149>
```

### **Parameters:**

There are no parameters for this command

### **Defaults:**

Command 149 defaults to '\*\*3' for the command name

### **Notes:**

- This command is a short-cut way to Command 51.

### **Error Codes:**

(System wide errors are listed in front of the manual)

### **Example 1:**

I just received my 30 second warning on the autopatch. I need to lengthen the call

```
**3 D or unkey
```

### **Response:**

"Autopatch Timer Start"

## *Chapter 14 Examples*

## ***Example 14-1: Configuring for 7 digit dialing***

The RLC-2 defaults with seven digit dialing enabled. See Command 127 to enable or disable this function. There are 2 modes that allow for 7 digit dialing. The first method requires the user to enter all the prefixes (first 3 digits of a 7 digit number) to be entered into the allow table (See Command 128). The second is simply enable 7 digit dialing for all entered prefixes. (See Command 127).

Allow table 7 digit dialing:

- I will allow the following prefixes 480,481,482,483,484,485,486,487

This entry will take 8 allow slots

- 128 01 480##### D or unkey	; Enable 480 dialing
- 128 02 481##### D or unkey	; Enable 481 dialing
- 128 03 482##### D or unkey	; Enable 482 dialing
- 128 04 483##### D or unkey	; Enable 483 dialing
- 128 05 484##### D or unkey	; Enable 484 dialing
- 128 06 485##### D or unkey	; Enable 485 dialing
- 128 07 486##### D or unkey	; Enable 486 dialing
- 128 08 487##### D or unkey	; Enable 487 dialing

Otherwise you could allow all 480..489 and let the phone company dis-allow the last 2 prefixes.

Let the phone company dis-allow the last 2 prefixes. The entry only takes 1 slot

- 128 01 48# ##### D or unkey ; Enables 480..489 dialing

If 7 digit dialing is not a problem for your group, simply forget the allow table and see Command 127 entry 5 to enable 7 digit, non-checked dialing. This still allows the dis-allow tables checking, it simply bypasses checking if the length is 7 digits.

Command 127 dialing control

- 127 # # # # 1 D or unkey ; '#..#' are other features controlled by '127'  
 (1) enables 7 digit dialing ;

## ***Example 14-2: Setting the controller for Callsigns on dialing***

The RLC-2 supports either 100 number dialing with callsigns assigned to those 100 slots, or 200 number dialing without callsigns assigned to the calling slots. The default configuration allows for the 200 number configuration. Command 134..137 are designed to configure, program and recall the callsign programming. Command 147 is the users access into callsign mode.

It is important not to execute Command 137 after you have programmed memory dial information in the 100..200 range. When this command is executed, the controller will erase all information contained in the 100..199 autodial range. This includes both number information and call sign information.

1) I want call signs enabled

137 1 D or unkey ; Enables callsign mode  
'Voice: Autopatch Call Route On'

2) I want memory dial 055 to contain the number 482-7515

132 055 482 7515 D or unkey ; Program the number into memory  
'Voice: 55 is 482 7515'

3) I want the message 'K F 7 F W' assigned to that slot

Looking up the words K(040) F(035) 7(007) F(035) W(052)  
135 55 01 040 035 007 035 052 D or unkey; Program the call into the slot routed to Port 1 when Command 147 is executed. For forward dialing the routing variable is not used.  
'Voice: 55 Call Is K F 7 F W Route Is 1'

4) I need to enable callsign readback with the autopatch

127 # # 1 1 # D or unkey ; '#' is other information  
'Voice: Autopatch Out Is # # 1 1 #'

Now when I make an autopatch call requesting memory dial slot 55, the controller will speak 'Auto Dial K F 7 F W' then dial the number.

For over the air paging using the callsign slots, the user simply executes Command 147 followed by 2 digits which indicate the callsign of the person being paged. This feature is where the audio routing variable that is programmed into the callsign slot is used. If the reverse autopatch pages you, and you are usually monitoring on port 1, then program an audio routing variable for the paged person as 01.

### ***Example 14-3: Reverse Autopatch Programming***

The RLC-2 supports user programming over the autopatch. In order for this mode to be enabled the controller needs to be configured as type 2 (See Command 126). When configured as type 2 the controller will answer after a number of rings and give the user a certain amount of time to execute a legal command. The initial timer is set to 20 seconds ( See Command 050,051,052 in the Timers chapter for changing the timer values). Once the autopatch answers the controller, the controller sends the default message 'Welcome To The Repeater, Please Enter Code Immediately'. If a valid command is not entered within the 20 second default timer, the controller will hang-up. Once a correct command is entered the controller sets the timer to the user timer which defaults to 1 minute. If the user logs on to the controller using Command 005, the timer is set for 3 minutes. All programming on the controller can be handled from the autopatch port.

Executing a command from the autopatch using the default forced execution digit requires the user to enable Command 023. This command allows timed execution. Timed execution refers to the execution of commands after a certain amount of time has expired since the last entered DTMF digit. This feature works well with the reverse autopatch allowing the users to execute commands without any special 'forced execution digit' being needed.

- 1) I want to page user #55 from the reverse autopatch
  - Call the repeaters autopatch
  - Once the voice message is over execute Command 147  
147 55 (Delay for 2 seconds) ; Over the repeater the message  
; 'Call for 'KF7FW' will be spoken
  
- 2) I want to get the recall the time from the reverse autopatch
  - Call the repeaters autopatch
  - Once the voice message is over execute Command 055  
055 (Delay for 2 seconds) ; Over the repeater the message  
; 'The Time Is XX:XX PM'
  
- 3) I need to connect the reverse autopatch (Port 4) to the repeater (Port 1)
  - Call the repeaters autopatch
  - Once the voice message is over execute Command 000 1 4  
000 1 4 (Delay for 2 seconds) ; Over the repeater the message  
; 'One Four Connect On'

A general rule:

- All programming that can be done from a radio port can be done over the patch
- When programming and you hear the message '30 seconds' execute the command \*\*3 (Command 148) which resets Port 4 (Autopatch) time-out timer.
- You must enable the timed execution command, Command 023 for reverse patch execution
- Audio routing variable 06 pertains the autopatch (See Command 007,008)
  - Set the variable to the ports you want ringing over when in Mode 1
  - Set the variable to the ports messages will go when in Mode 2



### ***Example 14-4: Direct Dialing Flowchart***

The following outlines the format the controller uses for verifying a numbers dialing possibilities. This table is for direct dialing numbers only.

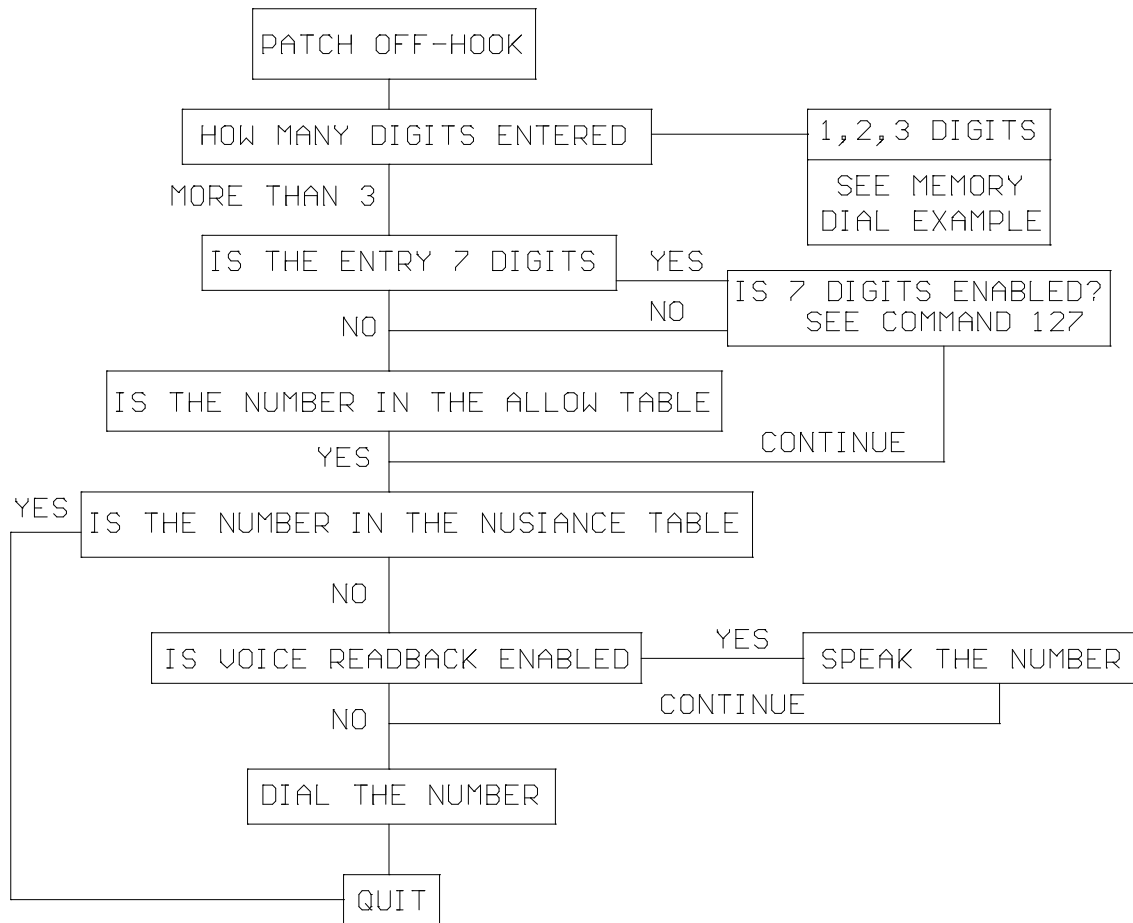

### ***Example 14-5: Memory Dialing Flowchart***

The following outlines the format the controller uses for verifying a numbers dialing possibilities. This table is for memory dialing numbers only.

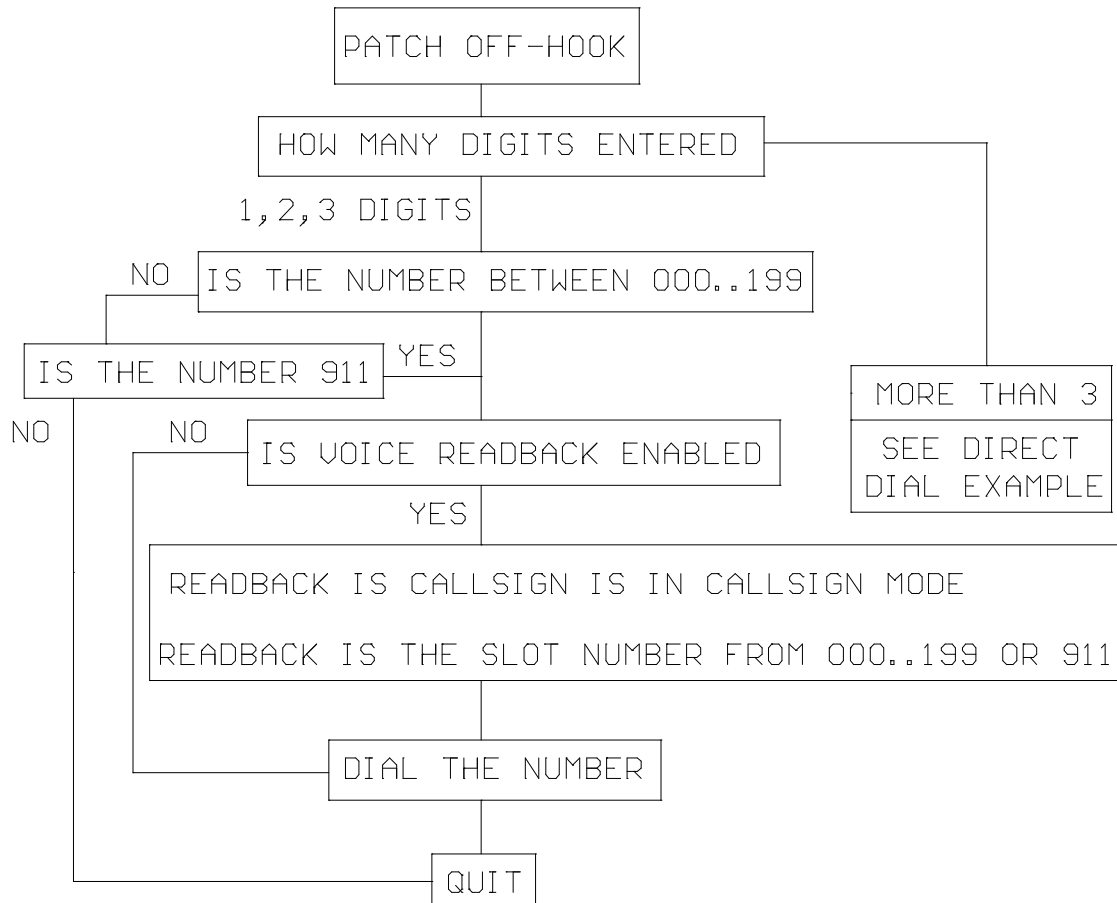

## ***Example 14-6: Autopatch Audio Routing***

- Autopatch audio routing

When the autopatch is requested by a radio port the controller automatically routes the audio to the ports that are connected to the autopatch. This allows connected ports to be in on the phone call and conversation. This also keeps one-way conversations from occurring.

- Half-Duplex audio routing

When the autopatch is in half-duplex mode, connected receivers effect how the autopatch audio is handled. In order to mute the autopatch audio any receiver that is connected to the autopatch must go active in order for the phones audio to be muted. In order to un-mute the phones audio all connected receivers must be inactive.

## ***Chapter 15: Digital Voice Recorders***

This chapter deals with the digital voice recorder options. The controller supports 2 models. Model 1 supports from 232 seconds on up of record time while model 2 supports 75 seconds of total record time.

## ***150: Playback Small DVR Slot 01..34***

This command allows the user to playback DVR message slots 01..34. These slots contain recorded voice messages. If a slot is not recorded, it will hold the transmitter up for no longer than 80 seconds. These message slots can also be accessed using special voice words. This allows the user to build voice messages using the message builder (See Command 048,049).

`<150> ss..ee`

### **Parameters:**

SS is the starting small DVR slot. This number ranges from 01..34

EE is the ending small DVR slot. (Used only if tracks chained together)

### **Defaults:**

All message slots are empty

### **Notes:**

- Do not play a non-recorded DVR message slot. If you play a non-recorded message slot the controller will be waiting for the end-of-message indication to stop the playing. If this occurs you can either start a recorded message or reset the controller.

### **Error Codes:**

E1- Invalid message slot. This number must be between 01..34

E2 - Invalid DVR selected. See Command 153 for selecting the small DVR  
(System wide errors are listed in front of the manual)

### **Example 1:**

I want to play message slot 34

`150 34 D or unkey`

### **Response:**

"<DVR Voice Message>"

## ***151: Record a Small DVR Slot 01..34***

This command allows the user to record a small DVR message track. The messages can be either 2 lengths. Slots 01..25 are 1 second slots, and slots 26..34 are 5 second slots. This results in a total recording time of 75 seconds.

```
<151> ss or xx.yy
```

### **Parameters:**

SS is the small DVR slot. This number ranges from 01..34

or...

XX is the first slot to begin recording

YY is the ending slot to stop recording

### **Defaults:**

All message slots are empty.

### **Notes:**

- When executing this command, the DVR begins recording upon drop of receiver access or when the DTMF tone goes away. The easiest recording style is to force execution of this command with the 'D' then begin talking. To finish the recording press another DTMF digit or unkey. The DVR will backup and delete the DTMF burst to format a nice sounding message.

### **Error Codes:**

E1- Invalid message slot. This number must be between 01..34

E2 - Invalid DVR selected. See Command 153 for selecting the small DVR  
(System wide errors are listed in front of the manual)

### **Example 1:**

I want to record message slot 34 with my initial ID.

```
151 34 D then begin to talk then a D or unkey
```

### **Response:**

"Recorded message played back"

## ***152: Delete a Small DVR Slot 01..34***

This command deletes a dvr tracks contents. Once the track is deleted it can not be recalled. Playing a deleted track can result in a small transmitter blip. This is due to the only way to delete a small dvr slot is to record a very short message into the slot (125mS).

```
<152> ss
```

### **Parameters:**

SS is the small DVR slot. This number ranges from 01..34

### **Defaults:**

All message slots are empty.

### **Error Codes:**

E1- Invalid message slot. This number must be between 01..34

E2 - Invalid DVR selected. See Command 153 for selecting the small DVR  
(System wide errors are listed in front of the manual)

### **Example 1:**

I want to delete my recordings in slot 34.

```
152 34 D or unkey
```

### **Response:**

Voice: "DVR <DVR Slot Number> Cancel"

## ***153: Select DVR Types***

This command selects the type of dvr connected to the controller. If you select a small dvr and try to use the large dvr's functions, you will get an error.

```
<153> x
```

### **Parameters:**

X is the DVR type

0 - Small DVR

1 - Large DVR

### **Defaults:**

Small DVR is selected

### **Error Codes:**

E1 - Invalid DVR mode. This number must be between 0..1

(System wide errors are listed in front of the manual)

### **Example 1:**

I want to configure the controller for the large DVR.

```
153 1 D or unkey
```

### **Response:**

Voice: "DVR Select <1 or 0>"



# *The Large Digital Voice Recorder*

## ***What the DVR is:***

The optional DVR is a device that allows you to record sounds, store them in memory and play them at any time. It can be used to personalize your controller by recording any message or sounds that you want and playing them back for ID messages or in place of most other synthesized voice messages. Some of these messages are played in response to commands that you or the users enter; others are played at certain times, such as for an ID. Both types of messages will be described below.

## ***DVR Tracks:***

All DVR recordings are stored in numbered "tracks." Certain tracks have special purposes and are played automatically at certain times. Others are available for you to use in any way you wish. The length of each track is limited only by available memory. Each track uses only as much storage space as is actually needed.

The first 250 tracks (numbered 000..249) have no predetermined use - you may use them for ID messages or anything else you can think of. Tracks 250..260 or so are used for prompting. They are discussed further in the section below titled "Recording the Prompting Tracks". The remaining tracks are not directly accessible by number. They are used to support the mailbox features and are automatically accessed by the mailbox commands.

## ***Public Mailboxes:***

The DVR uses special internal tracks to provide two types of mailboxes: public and private. Both types allow you to leave messages for other repeater users. You can leave a message in a public mailbox by simply entering the "Leave Public Mail" command (after setting up the prompting tracks as described below). The DVR will then ask you who the mail is for. You key up and say their name or call sign. The DVR will then ask you to record your message. When you are through, it will tell you that your message has been stored. You can check if there is mail for you by simply entering the "Check Public Mail" command. It will list the names or call signs of the people that there is mail for, or will tell you that there is no mail. If there is mail for you, you can listen to your message by entering the "Retrieve Public Mail" command. Up to nine public mailboxes can be in use at a time.

## ***Private Mailboxes:***

Private mailboxes allow you to leave voice mail in someone's private mailbox. To do this you have to know the number of their mailbox. There are 1000 private mailboxes, so everyone in your club can have their own. Each private mailbox can hold up to five messages at a time. You can retrieve or delete the mail in your own mailbox without affecting anyone else's mailbox.

## ***Interfacing:***

The DVR can be ordered with or without an optional rack mount cabinet. There is not enough room to mount it inside of the RLC-2 cabinet. Instead, there is a small interface board that plugs into the RLC-2 motherboard's "DVR Connection", near the autopatch connector. This interface board should be installed with the chips and connector towards the edge of the RLC-2 motherboard (and the blank side of the interface circuit board toward the circuit board). A short ribbon cable connects this interface board to a DB-25 female connector that is mounted to the RLC-2a case.

A DB-25 male-male cable (included) plugs into this connector and into the DVR. The only other required connection to the DVR is power (12 volts, center positive, plug included). Optional connections include a backup power plug that can be connected to a battery pack or another power supply (make sure ground is common between the supplies) to preserve the messages stored in the DVR if the main power goes out. The remaining connector can be connected to a computer or serial terminal (more about that later). Note that this serial port is separate from the serial port on the controller.

## ***Memory Installation and Testing:***

The DVR supports four different memory configurations, all using 80ns or faster standard 30 pin simms. Either 8 or 9 bit wide simms can be used; the parity bit is ignored. You may be able to find 8 bit wide simms cheaper (they are used in Macs). Each configuration requires a different set of EPROMS in the DVR:

- Two one megabyte simms (2 megabytes total)
- Four one megabyte simms (4 megabytes total)
- Two four megabyte simms (8 megabytes total)
- Four four megabyte simms (16 megabytes total)

If only two simms are installed, they must be in the RAM #1 sockets. Note that all of the simms must be the same size. All of the memory is tested each time the DVR is powered up. If you want to see the results of the memory test, connect a computer or serial terminal to the DVR (it need not be connected to the RLC-2 at this time) and power up the DVR. You should see a printout on the serial screen noting how much memory is expected (based on which version of the EPROMS you have) and then how the memory test is progressing. If the DVR does not run at all, check the power and the serial connection. The DVR will attempt to run even if errors are detected during the memory test. If the memory test indicates that there are many errors, you may have the wrong size or number of simms installed, or the simms may be faulty. If there are only a few errors, you may be able to use the simms with errors in the RAM #2 sockets with only a slight loss of audio quality. Errors in the simms installed in the RAM #1 sockets are likely to cause serious problems.

The memory test performed when the DVR is powered up is very thorough and therefore can take quite a while, especially if you have a lot of memory installed, so you may have to wait for it to finish before testing. With 2, 4, 8 and 16 megabytes of memory, the test takes about 20, 40, 80 and 160 seconds (about 2.5 minutes), respectively. Since you won't be powering up very often, this shouldn't be a problem.

If you have the serial port connected and the serial screen scrolls constantly after the memory test is finished, it is probably because you don't have the DVR connected to the controller, or the controller is

not powered up.

### ***Audio Quality/Recording Time:***

The audio quality of tracks played with the DVR is nearly identical to the original. You will probably not be able to distinguish between a recording and someone talking "live." Technically, the DVR samples and plays audio at 8KHz with 8 bit resolution (256 voltage levels). This uses 64000 bits per second, which is 8000 bytes per second. At this rate, each megabyte of memory will hold 131 seconds of recorded audio. A small portion of the memory is used for other purposes, so the actual amount of storage will be slightly less than 131 seconds per megabyte. In a future software version, it may be possible to record with lower quality to extend the recording time.

### ***Adjusting the DVR:***

There are only two adjustments on the DVR: record level and playback level. Both are preset before the DVRs are shipped, and should not need to be changed, at least for initial testing. When/if you do decide to adjust the levels, the playback level should be set so that the audio is played back at the same volume it was when it was "live". If you decide to change the record level, the playback level should be adjusted again before any judgement is made as to whether the new record level is better or worse. The record level is important because it affects the quality of the recording. If it is set too low, the full resolution of the digital storage will not be utilized and there will be more background noise in the audio than is necessary. If the record level is set too high, the audio peaks will be clipped off and the audio will sound distorted, especially the loudest parts.

There are many factors that determine the best level, so experiment with the Audio Check Command and adjust the record level until it sounds the best. Looking at the audio with a scope as it is played back will help identify if the record level is set too loud, as the top and bottom of the waves will be flattened (a little bit of clipping on the louder parts is normal and expected). If you have a computer or serial terminal hooked up, you can also record a message with 163 and look at it with the software oscilloscope function to see how much of the available range you are using.

The record and playback levels can be returned to the factory settings as follows: Set up a service monitor to generate a 1KHz tone with 3KHz deviation. Adjust the controller to get one volt peak to peak at the audio test point on the controller (the way the controller receive level is normally set up). Turn the generate function off. To make sure that the DVR is set up and working, use an HT to enter 163, unkey, key and say something, then unkey and listen. The DVR should play back whatever you said. If it does not, review the interfacing and testing sections above. Now key and enter Command 155 000, unkey, then turn the service monitor's generate function on. This will cause the DVR to record the 1KHz tone into track 0. Adjust the voltage at pin 1 of the DVR's audio test bus for one volt peak to peak. When you get it adjusted or after 30 seconds (when the DVR will automatically quit recording), turn the generate function off and enter Command 156 000 to erase DVR track 0. Repeat entering Command 154 000, recording the tone and erasing it with Command 156 000 until you are satisfied that the record level is set, then record the 1KHz tone into DVR track 0 once more and don't erase it. Play it back by entering Command 154 000. While it is playing, adjust the voltage at pin 3 of the DVR's audio test bus for one volt peak to peak. Command 154 000 may be entered as many times as needed to get the level set. This sets the DVR to play back tracks at the exact same level they were recorded at. If the transmit level is set correctly on the controller, playing this track should cause about 3KHz of deviation. Finally, erase track 0 by entering Command 156 000.

## ***The Audio Check Command:***

Before executing any DVR commands on the RLC-2 you should enter Command 153 1 to tell the RLC-2 that the large DVR is installed. The controller will respond by saying "DVR Select one". If you do not do this, some of the commands will work, but others will not.

The easiest way to test the DVR is to execute the "Audio Check" command. To use it, simply key your radio and enter "163", and say something. When you unkey or enter a 'D', the DVR will play whatever you said back to you, then erase it. If this command works, you have the DVR connected and working. You can execute this command as many times as you want to without harm and without wearing anything out. It can also be used to help you know if your signal is noisy into the repeater; just use this command to record a test message and you can listen to your own audio. Yet another use for this command is to find out how much record time (memory) is still available. To do this, start recording and count off the minutes and seconds you have been recording. When the DVR's memory is full, it will stop recording. When you unkey and the message is played back, you will hear yourself count as long as the DVR was able to record before it ran out of memory (this could take a long time if the memory is not almost full - if it takes too long, the max record length timer could stop it before the memory is full).

## ***Recording DVR Tracks:***

Before recording a track, you should make sure it is empty. If a track has already been recorded, you will not be able to record it again until you erase it. All tracks are empty when the DVR is powered up.

To record a track using the COR to start and stop the recording, you should enter the record command followed by the track number, "155 TTT" (where TTT is the track number), then unkey (to tell the controller to execute that command and get ready to record). Then key up and start speaking your message. When you are finished, simply unkey. The DVR will automatically delete a fraction of a second of the beginning and end of your message to get rid of any noise caused by keying or unkeying.

If you wish to record a track without using COR, such as from the reverse autopatch in programming mode, you can use a DTMF digit to start and stop the recording. For example, to record track 0, you could enter "155 000 D". As soon as you release the 'D', the DVR will begin recording. When you are finished speaking your message, press any DTMF digit to stop the recording. The DVR will automatically delete a fraction of a second at the end of your message to make sure that the sound of the DTMF digit is completely erased. Note that some phones (especially ones that can be used as speakerphones) mute about the first 1/2 second of each phrase you say; this makes recording nice DVR messages with them very difficult.

After you have recorded the prompting tracks (described later), the recording is more friendly by playing a DVR track that says something like "Please record you message now" after you enter the command and unkey (or press 'D').

When recording you must start recording within 10 seconds of entering the record command and unkeying or you will have to enter the command again. This is so a record command can't be entered and end up recording someone that keys up an hour later not knowing that the record command was the last thing entered.

The only limit on the length of message that can be recorded is the amount of memory that is still available. To keep people from leaving long mailbox messages, timers:

57 - Public mailbox message length (Default to 10 seconds) Command 160

58 - Public mailbox callsign length (Default to 5 seconds) Command 160

59 - Private mailbox per-message length (Default to 30 seconds) Command 158

60 - General message length (Default to 10 seconds) Command 155, Command 163

You may also need to lengthen your time out timer to record very long messages.

### ***Playing Messages:***

There are many things that can cause a DVR message to be played. For example, 163 records a message, then plays it back automatically. Command 155 XXX plays a message to tell you to start recording a new message, then lets you record it. To simply play a message that has already been recorded, you can use Command 154 XXX.

### ***Erasing Tracks:***

There are several reasons to erase tracks. Tracks that have been recorded before must be erased before they can be recorded again. Tracks that are no longer being used should be erased to make more storage space available for new messages. Once a track has been erased, there is no way to recover it, so be careful when deleting tracks, especially when deleting a whole range at once from the serial port. Deleting tracks can take several seconds, so don't be surprised if it takes a while before you hear the message erased message. If you are erasing a single message, the controller will continue to run normally while it waits for the DVR to finish deleting the message and send "message erased".

## ***Recording the Prompting Tracks:***

There are several special messages that are played automatically at certain times. They should be recorded before attempting to use the prompted record command or the mailboxes. The messages shown below are only suggestions; you can record them to say anything you want them to. To record them, enter the commands and speak the messages shown below. For more information about recording tracks, see the "Recording Tracks" section above.

Command 155 250	"Please record your message now"
Command 155 251	"Your message is stored"
Command 155 252	"Message erased"
Command 155 254	"Who is your message for?"
Command 155 255	"There are no messages."
Command 155 256	"There is mail for..."

If you want to see how your messages sound, you can play most of them by entering Command 154 250<unkey> (for track 250). Message 256 can not be checked this way, so record it and don't worry about checking it until you try out commands 160..162, 068. If you want to erase one of these tracks so you can record it again, enter Command 155 250<unkey> (to erase track 250). After recording these messages, the DVR is ready for use. Flip through the manual and try all of the commands until you are comfortable with them. If you want to erase all of your messages and start over, you can erase them serially or you can unplug the DVR and controller for several seconds, then power them back up (and wait for the DVR to finish its memory test).

## ***The Serial Interface:***

The DVR includes a serial port for interfacing to a serial terminal or a computer running terminal software. This connection is not needed for normal operation, but it does provide some capabilities that are not available otherwise. Some of these are:

- The messages in the DVR can be downloaded to a computer with a hard drive for backup, including the public and private mailboxes. In the event that both the main and backup power supplies fail and the DVR's memory is erased or you have to power down to install a software upgrade, you will be able to restore all of your messages. When the messages are downloaded, it is also relatively easy to edit out dead space at the beginning and end of messages. Please note that because the DVR has such a large amount of storage and because serial port transfers are relatively slow, that downloading takes a very very long time, like overnight. It can also take up to twice as much space on the hard drive as the amount of memory you have installed in the DVR.
- A "software oscilloscope" function lets you view a graphical representation of what is stored in any one of the slots. This feature is not real-time and requires that your serial terminal or terminal emulation software supports ANSI cursor control commands (most do). This feature is useful for checking how much of the range of the analog to digital converter is being used.
- A status display lets you check how much storage time is used for each message and mailbox. This can help you know what you should delete when the memory gets full.

If you have connected a terminal or computer to your RLC-2, all you have to do is unplug the cable from the RLC-2 and plug it into the DVR. The default setting is 9600 baud, N81, the same as the default for

the RLC-2. If you do not already have a cable and your computer or serial terminal has a DB-9 connector, you can use a straight through DB-9 cable (not a null modem cable). If you are using a modem or TNC, note that pins 2 and 3 will have to be swapped (a null modem adapter will do this). If you are using a modem or TNC, you will probably have to set them up to make them work transparently - contact Link Communications if you need more information about how to do this.

If everything you type shows up double on your serial screen like this "tteesstt", turn the local echo off on your communications program.

The DVR is unavailable to the controller while it is executing a command entered from the serial port. Because of this, most of the serial commands will time out if you do not respond within about 10 seconds. Pressing the escape key will also get you out of most commands.

The default baud rate of 9600 baud works well for both uploading and downloading. Faster baud rates are supported, but may not work reliably. Downloading may work at a higher baud rate than uploading. When uploading, you may have to set the character pacing time (check the ASCII transfer settings on your communications program) to avoid overruns. The line pacing can be set relatively small, often to 0. When uploading at high baud rates, if the data that appears on your screen has missing or incorrect characters but you are not getting error messages, the data is probably being uploaded correctly and you can ignore the incorrect characters that you see on the screen. Most errors in uploading are caused by trying to upload to a track that is not empty. If the DVR is reset either by powering it down or by the serial reset commands, the baud rate is automatically reset to 9600 baud.

## 154: Play DVR Track

This command allows the user to playback a general message recorded slot. These slots are designed to contain the users ID's, BBS messages and any general messages used. The controller prompts the user to record the message therefore allowing easy message storage.

<154> sss

### Parameters:

SSS is the DVR message slot

Slot Number	Definition	Parameters
000..249	General Messages	Play, Record, Erase
250	Please record your message	Play, Record, Erase
251	Your message is stored	Play, Record, Erase
252	Your message is erased	Play, Record, Erase
253	Not used	Play, Record, Erase
254	Who is you message for	Play, Record, Erase
255	There is no mail	Play, Record, Erase
256	There is mail for...	Play, Record, Erase
257	Callsigns with mail	Play Only
258	Not used	Play Only

### Defaults:

Small DVR is selected

### Error Codes:

E1 - Invalid DVR slot. This number must be between 000..258

E2 - Invalid DVR selected. See Command 153 for selecting the small DVR

(System wide errors are listed in front of the manual)

### Example 1:

I want to playback my prompted messages

154 sss D or unkey

### Response:

The DVR will playback your <SSS> requested message



## 155: Record DVR Track

This command allows the user to record a general message recorded slot. These slots are designed to contain the users ID's, BBS messages and any general messages used. The controller prompts the user to record the message therefore allowing easy message storage.

<155> sss

### Parameters:

SSS is the DVR message slot

Slot Number	Definition	Parameters
000..249	General Messages	Play, Record, Erase
250	Please record your message	Play, Record, Erase
251	Your message is stored	Play, Record, Erase
252	Your message is erased	Play, Record, Erase
253	Not used	Play, Record, Erase
254	Who is you message for	Play, Record, Erase
255	There is no mail	Play, Record, Erase
256	There is mail for...	Play, Record, Erase
257	Callsigns with mail	Play Only
258	Not used	Play Only

### Defaults:

Small DVR is selected

### Error Codes:

E1 - Invalid DVR slot. This number must be between 000..258

E2 - Invalid DVR selected. See Command 153 for selecting the small DVR  
(System wide errors are listed in front of the manual)

### Example 1:

I want to record my prompted messages

155 sss D or unkey

### Response:

DVR will prompt you to record your message with slot #254. Once prompted when you key your radio or hit a DTMF from the phone the recording starts. Upon receiving a DTMF digit or unkeying the recording stops and you are prompted with message #251.

## ***156: Erase DVR Tracks***

This command makes the DVR erase a specified track. There are several reasons to erase tracks. Tracks that have been recorded before must be erased before they can be recorded again. Tracks that are no longer being used should be erased to make more storage space available for new messages. Once a track has been erased, there is no way to recover it, so use this command with caution, especially when erasing a range of tracks.

```
<156> sss
```

### **Parameters:**

SSS is the DVR message slot. This number ranges from 000..256

### **Defaults:**

Small DVR is selected

### **Error Codes:**

E1 - Invalid DVR slot. This number must be between 000..256

E2 - Invalid DVR selected. See Command 153 for selecting the small DVR

(System wide errors are listed in front of the manual)

### **Example 1:**

I want to erase message slot 115

```
156 115 D or unkey
```

### **Response:**

Voice: 'Wait' then the DVR message slot #252 after the slot has been erased.

## ***157: Retrieve Private Mail***

This command allows a user to retrieve the mail that has been left in his private mailbox. If he has no mail, the special DVR track "You have no mail" will be spoken. If there is more than one message in his mailbox, all of them will be spoken consecutively.

```
<157> sss
```

### **Parameters:**

SSS is the DVR message slot

### **Defaults:**

Small DVR selected

All message slots are erased

### **Notes:**

- Each private mailbox supports up to 5 mail messages left. Remember to take your private mailbox timer and multiply by 5 to get a total mailbox length.

### **Error Codes:**

E1 - Invalid DVR slot. This number must be between 000..999

E2 - Invalid DVR selected. See Command 153 for selecting the small DVR

(System wide errors are listed in front of the manual)

### **Example 1:**

I want to check my voice mail messages. My mailbox is #112

```
157 112 D or unkey
```

### **Response:**

Either the DVR will speak the mailbox contents or will speak the message slot #255

## ***158: Record Private Mail***

This command allows the user to record a message and store it in a private mailbox. You must know the mailbox number you wish to leave a message in to use this command. Since each user has his own mailbox, there is no need for you to record his name or call sign as with the public mailboxes.

```
<158> sss
```

### **Parameters:**

SSS is the DVR message slot

### **Defaults:**

Small DVR selected

All message slots are erased

### **Notes:**

- Each private mailbox supports up to 5 mail messages left. Remember to take your private mailbox timer and multiply by 5 to get a total mailbox length.

### **Error Codes:**

E1 - Invalid DVR slot. This number must be between 000..999

E2 - Invalid DVR selected. See Command 153 for selecting the small DVR

(System wide errors are listed in front of the manual)

### **Example 1:**

I want to check save voice mail in slot #112.

```
158 112 D or unkey
```

### **Response:**

DVR will prompt you to record your message with slot #254. Once prompted when you key your radio or hit a DTMF from the phone the recording starts. Upon receiving a DTMF digit or unkeying the recording stops and you are prompted with message #251.

## ***159: Erase Private Mail***

This command throws away the contents of a private mailbox, the last one that was retrieved. It must be used only after retrieving a private mailbox message with 157. It erases all of the messages in that mailbox, but does not affect any of the other private mailboxes.

```
<159> sss
```

### **Parameters:**

SSS is the DVR message slot

### **Defaults:**

Small DVR selected

All message slots are erased

### **Notes:**

- Once a message is erased, it can not be recalled. Used this item with care.

### **Error Codes:**

E1 - Invalid DVR slot. This number must be between 000..999

E2 - Invalid DVR selected. See Command 153 for selecting the small DVR

(System wide errors are listed in front of the manual)

### **Example 1:**

I want to delete my mail in slot #112

```
159 112 D or unkey
```

### **Response:**

Voice: 'Wait' then the DVR message slot #252 after the slot has been erased.

## ***160: Record Public Mail***

This command allows the user to record a message and who it is for and stores it in a public mailbox. It uses some of the special tracks to prompt the user to record the name or call sign and the message, and to tell him that the message has been stored. For more information, see the "Public Mailboxes" section at the beginning of the DVR section.

<160>

### **Parameters:**

There are no parameters for this command

### **Defaults:**

Small DVR selected  
All message slots are erased

### **Error Codes:**

E1 - Invalid DVR selected. See Command 153 for selecting the small DVR  
(System wide errors are listed in front of the manual)

### **Example 1:**

I want to leave a message for KC7HXB, I am KF7FW

160 D or unkey

### **Response:**

Once public mail is requested the following prompting takes place:

- 1) DVR Prompts: Who is your message for? (Message slot #254)
- 2) Key your radio in 10 sec. or less and speak the call of the person the mail is for  
<Key Radio> KC7HXB
- 3) DVR Prompts: Please record your message.(Message slot #250)
- 4) Key your radio in 10 sec. or less and speak the message for the person the mail is for  
<Key Radio> "John Doe, Please call me, KF7FW"
- 5) DVR Prompts: Your message is stored.(Message slot #251)

Now by executing command 068 or speaking the custom word 772, the response is...

- 1) DVR Prompts: There is mail for... (Message slot #256)
- 2) Lists the calls of those with mail "KC7HXB (and any others) (Message slot #257)"

You simply need to execute command 161 to retrieve the mail by counting the callsigns and selecting the callsign from the names listed.

## ***161: Retrieve Public Mail***

This command allows a user that has mail in a public mailbox to retrieve it. This command is usually used after checking the public mailboxes with command 068 or speaking special word 772. When you check the public mailboxes with 068, you should keep track of where your name or call sign are in the list of people that have mail. For example, if 068 says, "There is mail for Joe, Mary, Bob, Jim", and you are Bob, your mail will be stored in public mailbox #3, because your name is third in the list. To retrieve your mail, you would enter "161 3 D or unkey".

```
<161> s
```

### **Parameters:**

S is the number in the list of names listed. This number ranges from 1..9

### **Defaults:**

Small DVR selected

All message slots are erased

### **Error Codes:**

E1 - Invalid slot selected. This number must be between 1..9

(System wide errors are listed in front of the manual)

### **Example 1:**

I want to read message #5 from the list of mail I heard in Command 068

```
161 5 D or unkey
```

### **Response:**

DVR will speak that message slot

## ***162: Erase Public Mail***

This command throws away the contents of a public mailbox, the last one that was retrieved. It must be used only after retrieving a public mailbox message with 161. It erases only the last public mailbox message that was retrieved; all of the others remain unchanged (although they may be moved up to a lower numbered mailbox to avoid leaving gaps).

`<162> s`

### **Parameters:**

S is the number in the list of names listed. This number ranges from 1..9

### **Defaults:**

Small DVR selected

All message slots are erased

### **Error Codes:**

E1 - Invalid slot selected. This number must be between 1..9  
(System wide errors are listed in front of the manual)

### **Example 1:**

I want to delete message #5 from the list of mail I listened to in Command 161

`162 5 D or unkey`

### **Response:**

Voice: Wait DVR then speaks your message is erased (slot #252)



## ***068: Check Public Mailboxes***

This command recalls who has mail in the public mailboxes. The DVR will either play the special track that says, "There is mail for", then the name or call sign for each of the messages that are stored in the public mailboxes or it will play the special track, "There is no public mail". The names or call signs will be spoken in the order that the messages were recorded.

<068>

### **Parameters:**

This command allows the user the check if there is any public mail waiting to be read. This command is also accessible as a special voice word.

### **Defaults:**

- There is no public voice mail
- Small DVR selected
- All message slots are erased

### **Error Codes:**

E1 - Invalid slot selected. This number must be between 1..9  
(System wide errors are listed in front of the manual)

### **Example 1:**

I want to check if there is any public mail

068 D or unkey

### **Response:**

"DVR will playback either <There is mail for ...Callsigns> or <There is no mail>"

## ***163: Record and Play Audio Test***

This command makes the DVR start recording. When you unkey or press a DTMF digit to stop recording, it automatically plays it back. This is useful for testing the DVR and for checking how your signal sounds into the repeater. To use this command enter 163D and start speaking immediately. When through speaking, unkey and your recording will be played back immediately. The track is automatically erased after it is played back.

<163>

### **Parameters:**

There are no parameters for this command

### **Defaults:**

- There is no public voice mail
- Small DVR selected
- All message slots are erased

### **Error Codes:**

E1 - Invalid DVR selected. Refer to Command 153 to select correct DVR.  
(System wide errors are listed in front of the manual)

### **Example 1:**

I want to check my relative signal strength into the repeater

163 D then talk then D or unkey

### **Response:**

"DVR will playback what you recorded"

## *Chapter 15 Examples*

This chapter deals with the requirements to set the large DVR system up for voice mail, and signal testing. These examples require the RLC-DVR1 be installed into the system before testing the features.

## ***Example 15-1: Setting up message slots for Voice Mail***

There are several message slots that are reserved for the voice mail system

Slot Number	Definition	Parameters
250	Please record your message	Play, Record, Erase
251	Your message is stored	Play, Record, Erase
252	Your message is erased	Play, Record, Erase
254	Who is you message for	Play, Record, Erase
255	There is no mail	Play, Record, Erase
256	There is mail for...	Play, Record, Erase
257	Callsigns with mail	Play Only

The procedure for initially setting up the DVR system is to record slot 250, 251, and 252.

- 1) Tell the controller the RLC-DVR1 is connected  
 - 153 1 D or unkey ; Large DVR connected
- 2) For this example we will set-up the system over the air  
 - 154 250 D <Speak "Please Record Your Message Now"> then hit any DTMF digit or unkey your radio. This records message slot 250.
- 3) For this example we will set-up the system over the air  
 - 154 251 unkey ; Ready the recording of a message  
 - When you unkey the controller will prompt you to "Please Record Your Message Now". When the DVR stops playing you must key up and speak <Your Message Is Stored> then hit any DTMF digits or unkey your radio. The DVR will respond "You Message Is Stored".
- 4) For this example we will set-up the system over the air  
 - 154 252 unkey ; Ready the recording of a message  
 - When you unkey the controller will prompt you to "Please Record Your Message Now". When the DVR stops playing you must key up and speak <Your Message Is Erased> then hit any DTMF digits or unkey your radio. The DVR will respond "You Message Is Stored".

Your mail system is now ready. Review Commands 160,161,162,068 for public mail access

## ***Chapter 16: Macros***

Macros refer to commands that can store several commands but can be called with one command. Applications of macros include setting up the repeater into special modes, scheduling events and any type of execution that you want to call with 1 name and no additional data. The controller supports 70 macros with 50 keystrokes per macro.

## ***164: Serial Recall a range of Macros***

This command is the same as command 167 except it recalls a range of macros serially. The serial output is in a formatted uploadable format. Simply put your terminal into capture mode and specify the range of macros that you want to view and/or edit. Once your changes are complete you can upload the captured file and the controller will accept the data as a normal entry. This command can be executed from the serial port only.

```
<164> xx yy
```

### **Parameters:**

XX is the beginning macro to be viewed.

YY is the ending macro to be viewed.

XX and YY must range between 01..70

### **Defaults:**

There are no defaults for this command

### **Notes:**

- XX must be smaller than YY.

### **Error Codes:**

E1 - Invalid execution source. Only serial is enabled to execute this command

E2 - Invalid macro number. Number must be between 01..70

E3 - Macro number mis-match. XX must be smaller than YY

### **Example 1:**

I want to download macros 01..20

From the serial port enter

```
164 01 20 D or Enter
```

### **Response:**

ASCII formatted download file

## ***165: Erase a Macro Position***

This command erases a macro position. When a position is erased, the macro need to be re-programmed. To just enable/disable the macro, refer to Command 166.

```
<165> ss
```

### **Parameters:**

SS is the macro number. This number must be between 01..70

### **Defaults:**

All macros are erased

### **Error Codes:**

E1 - Invalid macro slot.

(System wide errors are listed in front of the manual)

### **Example 1:**

I need to erase macro 15 before I reprogram it with new data

```
165 15 D or unkey
```

### **Response:**

"Position <Slot Number> Clear"

## ***166: Enable/Disable a Macro Position***

This command controls if a macro can be executed. Once a macro is programmed, the user can enable/disable a macro without effecting its contents.

```
<166> ss y
```

### **Parameters:**

SS is the macro number. This number must be between 01..70

Y is the control variable

0 - Disables the macro

1 - Enables the macro

### **Defaults:**

All macros are erased and disabled

### **Error Codes:**

E1 - Invalid macro slot. Number must be between 01..70

E2 - Invalid mode. Mode must be either a 1 or a 0

(System wide errors are listed in front of the manual)

### **Example 1:**

I need to disable macro 15

```
166 15 0 D or unkey
```

### **Response:**

"Position <Slot Number> <ON/OFF>"



## ***167: Recall a Macro Position***

This command recalls the programming positions of a macro. Because there can be several commands in a macro with variable lengths of additional data, the user needs to be able to read back the macro position to find what is in the macro. When this command is entered from the serial port the response is formatted in a serially uploadable file.

```
<167> ss
```

### **Parameters:**

SS is the macro number. This number must be between 01..70

### **Defaults:**

All macros are erased and disabled

### **Error Codes:**

E1 - Invalid macro slot. Number must be between 01..70

E2 - Invalid mode. Mode must be either a 1 or a 0

(System wide errors are listed in front of the manual)

### **Example 1:**

I need to recall macro 15

```
167 15 D or unkey
```

### **Response:**

If the macro is erased the response is:

"<Slot Number> is Off, Input is Clear"

If the macro is programmed the response is:

"<Slot Number> is ON,

"Input is <Command Number> With <Additional Data>

"Next input is" ...

If executed from serial

; Macro <Macro Number>

168 <Macro Number> <Command Name> <Additional Data if Any>

.

.

168 <Macro Number> <Command Name> <Additional Data if Any>

; End of the macro

## ***168: Program/Append a Macro Position***

This command allows the user to program a macro position and append new commands into a macros. The macro positions can take up to 50 keystrokes per macro. Macros can call other macros up to 10 levels of calling.

```
<168> ss xxx y..y
```

### **Parameters:**

SS is the macro number. This number must be between 01..70

XXX is the command number. This number must be between 000..245

Y..Y is the additional data for the command if the command requires additional data

### **Defaults:**

All macros are clear and disabled

### **Notes:**

- When counting keystrokes for a macro position
  - 1) Command numbers (XXX) count as 2 keystrokes, not 3
  - 2) Additional data digits count as 1 digit per entered digit
  - 3) Do not have macros call themselves. If this occurs a macro depth limit error will occur.

### **Error Codes:**

E1 - Not enough data entered. Minimum data entered is 5 digits. 2 for the macro number and 3 for the command name.

E2 - Invalid macro position. Number must be between 01..70

E3 - Macro overfull occurred. When this error is requested, the data you are appending onto a macro is more than the macro can hold. Try putting the next data in another macro and calling the second macro from the first.

E4 - Invalid Command name programmed in. Command names must be between 000..245  
(System wide errors are listed in front of the manual)

### **Example 1:**

I want to program macro 01 to speak a voice message

"Welcome to the Repeater, <Female Time>"

```
168 01 045 468 002 421 361 528 702 D or unkey
```

### **Response:**

"Number <Macro> Programming <Command Name> With <Additional Data if any>"

***169: Cancel all Responses Following This Command***  
***170: Re-enables all Responses Following This Command***

These commands cancel and re-enable all responses following these command execution. The user would put this in a macro when programming to keep the command responses that are spoken when a macro executes from being spoken and to re-enable voice responses after execution. For example, I need to turn outputs 4,5,6,7,8 on using Command 092. I also want to speak the response PL 100 hertz ON. If I executed this command from the macro without using Command 169 before Command 092 I would get the following response: "PL 100 Hertz ON" "4 ON, 5 ON, 6 ON, 7 ON, 8 ON". If I place command 169 between the Speak voice message and turn Output Line ON command my response would be "PL 100 Hertz ON" and nothing more. At the end of the macro you will need to execute Command 170 to re-enable the voice response.

Cancel responses following this command

<169>

Enable responses following this command

<170>

**Parameters:**

There are no parameters for this command

**Error Codes:**

(System wide errors are listed in front of the manual)

**Example 1:**

From the above mentioned example placed in macro 02

- |  |                               |
|--|-------------------------------|
| 1) 165 02 D or unkey                             | ; Clears macro #02            |
| 2) 168 02 045 045 041 001 028 212 310 D or unkey | ; Programs the voice response |
| 3) 168 02 169 D or unkey                         | ; Cancels voice responses     |
| 4) 168 02 092 4 5 6 7 8 D or unkey               | ; Turn Outputs 4,5,6,7,8 ON   |
| 5) 168 02 170 D or unkey                         | ; Re-enable voice responses   |

By executing macro 02, Command 172, outputs 4,5,6,7,8 are turned on and the response spoken is 'PL 100 Hertz On'

**Response:**

There are no responses for these commands

## ***171..240: Execute Macro #01..#70***

These commands execute macro positions 01..70. Programming of the macros is accomplished using Command 168.

Name	Number	Name	Number	Name	Number
Macro 01	171	Macro 25	195	Macro 49	219
Macro 02	172	Macro 26	196	Macro 50	220
Macro 03	173	Macro 27	197	Macro 51	221
Macro 04	174	Macro 28	198	Macro 52	222
Macro 05	175	Macro 29	199	Macro 53	223
Macro 06	176	Macro 30	200	Macro 54	224
Macro 07	177	Macro 31	201	Macro 55	225
Macro 08	178	Macro 32	202	Macro 56	226
Macro 09	179	Macro 33	203	Macro 57	227
Macro 10	180	Macro 34	204	Macro 58	228
Macro 11	181	Macro 35	205	Macro 59	229
Macro 12	182	Macro 36	206	Macro 60	230
Macro 13	183	Macro 37	207	Macro 61	231
Macro 14	184	Macro 38	208	Macro 62	232
Macro 15	185	Macro 39	209	Macro 63	233
Macro 16	186	Macro 40	210	Macro 64	234
Macro 17	187	Macro 41	211	Macro 65	235
Macro 18	188	Macro 42	212	Macro 66	236
Macro 19	189	Macro 43	213	Macro 67	237
Macro 20	190	Macro 44	214	Macro 68	238
Macro 21	191	Macro 45	215	Macro 69	239
Macro 22	192	Macro 46	216	Macro 70	240
Macro 23	193	Macro 47	217	.....	.....
Macro 24	194	Macro 48	218	.....	.....

**Error Codes:**

There are no errors for a macro execution

(System wide errors are listed in front of the manual)

**Example 1:**

I need to execute macro 01

171 D or unkey

**Response:**

The response depends on what commands are inside the macros

## *Chapter 16 Examples*

## ***Example 16-1: Need to Configure certain Links***

This example the user needs to configure a link system normal that the users can call when turning the link system off, and a link system enabled for turning on the link system. These macros will contain several commands but can be called using only 1 command name. For this example we will use macro 01 for link on, and macro 02 for link off.

- Setting up the drop-out message

Dropout message for port 1 will be located in message slot 23. The message will speak 'Link Off' indicating the link system is currently off.

### **1) Program a message slot**

- 049 23 1 251 306 D or unkey ; Program message slot 23 with Link Off

Where (049) is the message program utility, (23) is the message slot, (1) indicates voice message, (251 - Link) (306 - Off)

### **2) Tell the drop-out message 1, port 1 what event to call when enabled**

- 064 021 1 023 01 D or unkey ; Set-up event slot 021

Where (064) is the event table program command, (021) is the drop-out event, (1) indicates a message fetched when the event is called, (023) is the message slot, (01) routes to port 1.

### **3) Disable the event until called by the link off command**

- 065 021 0 D or unkey ; Disable the event

Where (065) is the event table control, (021) is the event being controlled, (0) disables the event being called.

- Setting up the link on macro

This macro is what the user calls when enabling the link system.

### **1) Clear current macro contents**

- 165 01 D or unkey ; Deletes macro contents

### **2) Speak a response 'Link System On'**

- 168 01 045 251 407 310 D or unkey ; Program the speaking command

Where (168) is the macro program command, (01) is the macro number, (045) is the command to be programmed into the macro, (251-Link), (407-System), (310-On) are the words associated with command 045.

### **3) Connect Port 1 to Port 2**

- 168 01 000 1 2 D or unkey ; Program the connect command

Where (168) is the macro program command, (01) is the macro number, (000) is the command to be programmed into the macro, (1 2 ) connects port 1 to port 2.

### **4) Connect Port 1 to Port 3**

- 168 01 000 1 3 D or unkey ; Program the connect command

Where (168) is the macro program command, (01) is the macro number, (000) is the command to be programmed into the macro, (1 3 ) connects port 1 from port 3.

**5) Connect Port 2 and Port 3**

- 168 01 000 2 3 D or unkey ; Program the connect command

Where (168) is the macro program command, (01) is the macro number, (000) is the command to be programmed into the macro, (2 3 ) disconnects port 1 from port 2.

**6) Disable drop-out message 1, port 1**

- 168 01 065 021 0 D or unkey ; Program the event control command

Where (168) is the macro program command, (01) is the macro number, (065) is the command to be programmed into the macro, (021) is port 1's drop-out message 1, (0) disables the event

- **Setting up the link off macro**

This macro is what the user calls when disabling the link system.

**1) Clear current macro contents**

- 165 02 D or unkey ; Deletes macro contents

**2) Speak a response 'Link System Off'**

- 168 02 045 251 407 306 D or unkey ; Program the speaking command

Where (168) is the macro program command, (02) is the macro number, (045) is the command to be programmed into the macro, (251-Link), (407-System), (306-Off) are the words associated with command 045.

**3) Disconnect Port 1 from Port 2**

- 168 02 002 1 2 D or unkey ; Program the disconnect command

Where (168) is the macro program command, (02) is the macro number, (002) is the command to be programmed into the macro, (1 2 ) disconnects port 1 from port 2.

**4) Disconnect Port 1 from Port 3**

- 168 02 002 1 3 D or unkey ; Program the disconnect command

Where (168) is the macro program command, (02) is the macro number, (002) is the command to be programmed into the macro, (1 3 ) disconnects port 1 from port 3.

**5) Connect Port 2 and Port 3**

- 168 02 000 2 3 D or unkey ; Program the connect command

Where (168) is the macro program command, (02) is the macro number, (000) is the command to be programmed into the macro, (2 3 ) disconnects port 1 from port 2.

**6) Enable drop-out message 1, port 1**

- 168 02 065 021 1 D or unkey ; Program the event control command

Where (168) is the macro program command, (02) is the macro number, (065) is the command to be programmed into the macro, (021) is port 1's drop-out message 1, (1) enables the event

The macro sequence above required 29 keystrokes:

- 5 command names at 2 keystrokes each = 10
- 19 digits of additional data keystrokes = 19
- Total keystrokes = 29



## *Chapter 17: Serial Commands*

## 069: Serial LED Status Screen

This command requires separate DOS software available from Link Communications, Inc. World Wide Web site or for purchase from Link. This software emulates the front panel LED display on a serial screen. This is handy for troubleshooting the controllers operation. This command enables or disables the controllers data stream sent out the serial port to an attached computer. It is not advised to use this mode if in HF remote base mode.

```
<069> c
```

### Parameters:

- 069 is the default command name
- C is the serial control variable
  - 0 - disables serial status mode
  - 1 - Enables serial status mode

```

                                RLC-2 Status Display V4.17
. Input 1      X Output 1      . PL Main          X PTT Main
. Input 2      . Output 2     X COR Main         . PTT Link 1
. Input 3      X Output 3     . PL Link 1       . PTT Link 2
. Input 4      . Output 4     . COR Link 1     X DTMF Main
. Analog 1     . Output 5     . PL Link 2      . DTMF Link 1
. Analog 2     X Output 6     . COR Link 2     . DTMF Link 2
. Analog 3     X Output 7     . Control RX     . DTMF Patch
. Analog 4     . Output 8     . DTMF Act.     . DTMF Control

. Main TOT      . Serial 1      . Phone Ring
. Link 1 TOT    . Serial 2      . Phone Off Hook
. Link 2 TOT    . Serial 3     X Serial Log-On
. Main Hang     . Serial 4      . CW Tone
. Link 1 Hang   . Serial 5     X Voice
. Link 2 Hang   . Serial 6     X Main Access
. 1 Second     X Serial 7     . Link 1 Access
. DVR Active    . Serial 8     . Link 2 Access

DTMF TICKER TAPE WILL SHOW UP HERE . . . .

```

The display is updated once a second. When DTMF digits are received they will scroll across the bottom of the screen in the area marked 'DTMF Ticker Tape'.

### Software Parameters:

- From the DOS prompt type the following: STATUS2 P
  - Where Status2 is the program name
  - P is the COMM port 1,2,3,4
- Baud rate is set to 9600 baud

## ***241: Serial Upload Data File***

This command uploads a serial data file that was generated by the RLC-2 controller. This file will only upload V4.XX software blocks. Do not edit the upload file without using the Link Communications Inc. editor.

```
<241>
```

### **Execution Source:**

This command can only be executed from the RS-232 port

### **Parameters:**

There are no parameters for this command

### **Notes:**

- Once you enter command 241, the controller will prompt you to begin the upload. All functions on the controller will cease to operate except the serial system. Data files have been successfully uploaded at 9600 baud without errors. Once the upload is complete the controller will prompt you with a checksum match message. If the checksums do not match try a slower baud rate, or change your ASCII upload requirements character pacing timing. This may slow the upload but it will guarantee a successful transfer.

### **Error Codes:**

(System wide errors are listed in front of the manual)

### **Example 1:**

I need to re-upload my hex file after I re-initialized the controller

```
241 <Enter>
```

### **Response:**

There is no response for this command

## ***242: Serial Download Data File***

This command downloads the controllers memory contents from the controller to your computer. This will only currently download the main RAM block, not the autopatch RAM. Before executing this command set-up your computer for ASCII download. Once the computers file has been opened, execute Command 242. When the download has stopped and given you a file checksum, you can close the file.

```
<242>
```

### **Parameters:**

There are no parameters for this command

### **Defaults:**

There are no defaults for this command

### **Error Codes:**

(System wide errors are listed in front of the manual)

### **Example 1:**

I have completely set-up my controller. Now I need to save the contents on my computer incase of any problems.

```
242 <Enter>
```

### **Response:**

Serial download data on your screen

## ***243: Serial Command Name List***

This command lists all the controllers command names including execution sources, DTMF and serial locking.

<243>

**Parameters:**

There are no parameters for this command

**Defaults:**

There are no defaults for this command

**Error Codes:**

(System wide errors are listed in front of the manual)

**Example 1:**

I need a list of all the controllers command names.

243 D or unkey

**Response:**

Serial command name lists

## 244: *Change the Serial Baud Rate or Send Serial Data*

This command changes the serial baud rate for the RS-232 port if only 1 digit is entered. If 3 or more digits are entered the controller will convert those digits into serial data and send them.

<244> x y or xxx

### Parameters:

X is the serial baud rate

Baud Number	Baud Rate
0	9600
1	4800
2	2400
3	1200
4	600
5	300

Y is the echo control

Where 1 - disables serial output

0 - enables serial output

or...

XXX is a number from 000..255 which is the ASCII data send (See Appendix

### Defaults:

Baud rate defaults to 9600

### Error Codes:

E1 - Invalid baud rate

E2 - Invalid Serial character. Number must be between 000..255

(System wide errors are listed in front of the manual)

### Example 1:

I need to change my baud rate from 9600 to 2400 baud and enable serial output

244 2 0 D or unkey

### Response:

"Computer Programming Rate Is <X>"

There is no voice response when sending ASCII data

## *Chapter 17 Examples*

## *Example 17-1: Setting up the Serial Port*

I need to set-up the serial port to 2400 baud before I do a serial download.

1) Command 244 is provided to change the serial baud rate. Locate 2400 baud in the below table and enter the reference number into Command 244.

Serial baud rate

Baud Number	Baud Rate
0	9600
1	4800
2	2400
3	1200
4	600
5	300

2) Enter '2' into Command 244

244 2 0<Enter> ; Sets the baud rate to 2400 N-8-1 and enables serial output



## ***Example 17-2: I want to download the RAM into a file***

This example will take you through a session of downloading the controllers RAM content into a file on your computer. This file is a backup of your systems settings (except the autopatch). If the controller is ever re-initialized with version 4.XX software the user can then upload the file and maintain the previous settings before the initialization occurred.

- 1) Once you have set-up the computers baud rate to what the controller defaults to you can execute the download commands. If you have set the controller up correctly you should get the DTMF> prompt when you hit the <ENTER> key. If you do not get this verify your serial ports set-up.
- 2) Set-up your computers terminal software to ASCII download. Your computer will ask for a file name to save the file once received. Enter a name that is easy to remember.
- 3) Once you have entered a name and the computer is waiting to receive the file type the digits 242. This will execute Command 242. Once you have entered the command the controller will begin to send 'Garbage' looking data. This will continue for several seconds. At the end of the file download the controller will give prompt you to close your download file. Typical programs use the 'Escape' digit to close the file once the download is complete. The file length is typically 16,072 bytes long. If your file is much bigger or smaller beware of possible download problems.
- 4) To upload a file from the computers disk you will need to set-up your controller for ASCII file upload using Command 241. Once you execute Command 241 the controller will stop working until either a reset is received or the file upload session is complete. The steps in uploading a file:
  - Execute Command 241
    - The controller will prompt you to begin your upload or hit { } to terminate the upload process.
  - Upload the controllers file from your computers disk drive
  - Once the upload is complete the controller will state the calculated check-sum and the files expected checksum. If the checksums match the data that you uploaded to the controller matched what the controller downloaded. If the checksums do not match the file you uploaded has problems.
  - Failed checksums will leave the controller in an unknown state. Try re-uploading the file at a slower baud rate.

## *Chapter 18: Misc. Commands*

## ***116: Resistor #1,#2 Send Routine***

This command allows the user to change the on-board 50K $\Omega$  software resistors. The user enters a number that ranges from 000..255. This gives a 192 $\Omega$ /step resistance change. Applications for the resistors include remote control of the repeaters squelch and volume circuits. When using an HF remote base these are useful for remote HF squelch adjustment.

<116> x yyy

### **Parameters:**

X is the resistor needing changes

1 - Resistor 1

2 - Resistor 2

YYY is the resistance number selected

$$\text{Resistance } \Omega = 50\text{K}\Omega \div (\text{YYY})$$

### **Defaults:**

Both the resistors are set to 25K $\Omega$  or 128

### **Notes:**

- The resistors are AC coupled. For the protection of the resistor chip bypassing the coupling is not recommended. The resistors can take -5V to +5V worth of audio (10V). Do not exceed these limits. Exceeding will damage the resistor chip.

### **Error Codes:**

E1 - Invalid resistor. this number must be either 1 or 2

E2 - Invalid resistance number. This number must be between 000..255

(System wide errors are listed in front of the manual)

### **Example 1:**

I want to loosen my external squelch adjustment which is on resistor 1 to 055.

116 1 055 D or unkey

### **Response:**

"Number <Resistor Number> Ohms Of <Number>"

## *117: Recall Software Resistor Settings*

This command recalls the settings of the internal software resistors.

```
<117> x
```

### **Parameters:**

X is the resistor needing changes

- 1 - Resistor 1
- 2 - Resistor 2

### **Defaults:**

Both the resistors are set to 25K $\Omega$  or 128

### **Notes:**

- The resistors are AC coupled. For the protection of the resistor chip bypassing the coupling is not recommended. The resistors can take -5V to +5V worth of audio (10V). Do not exceed these limits. Exceeding will damage the resistor chip.

### **Error Codes:**

E1 - Invalid resistor. this number must be either 1 or 2  
(System wide errors are listed in front of the manual)

### **Example 1:**

I want to check my external squelch adjustment which is on resistor 1.

```
117 1 D or unkey
```

### **Response:**

"Number <Resistor Number> Ohms Of <Number>"

## ***245: Remotely Reset the Controller***

This command remotely resets the RLC-2 controller. This will not change any of the system variables, only provide a reset function.

```
<245>
```

### **Parameters:**

There are no parameters for this command

### **Defaults:**

There are no defaults for this command

### **Error Codes:**

(System wide errors are listed in front of the manual)

### **Example 1:**

I need to reset my controller to clear a condition

```
245 D or unkey
```

### **Response:**

"Controller Ready"

## *Chapter 18 Examples*

## *Example 18-1: Applications for the software resistors*

### Software Resistors and their Applications

The RLC-2 offers a unique option to the repeater controller. The controller offers two 50K $\Omega$  resistors controllable from your DTMF tone pad. Using this option, the RLC-2 can vary the resistance in 196 $\Omega$  steps with a total of 255 possible resistance values. With this feature, it is possible for the repeater operator to remotely control the squelch circuit of the repeater, volume of remotes, or vary the repeater's power output. These are just a few of the applications made possible by the software resistors. See Command 116, 117 for information on setting the value of the resistors.

### Software Resistor Interfacing Precautions

The software resistors are AC coupled using a 0.1 $\mu$ F capacitor. The capacitors are placed in series with the high side and the wiper side of the resistor (See below). Because of the added capacitors, only AC can be varied using the resistor. This guards against damaging +12V that would otherwise be fatal to the software resistors. When using the resistors, it is very important to remember that **the software resistors are a  $\pm 5$  Volt device, therefore the peak amplitude of the input signal cannot exceed the  $\pm 5$  Volt limit without damage to the resistor.**

### *Squelch control with a Software Resistor*

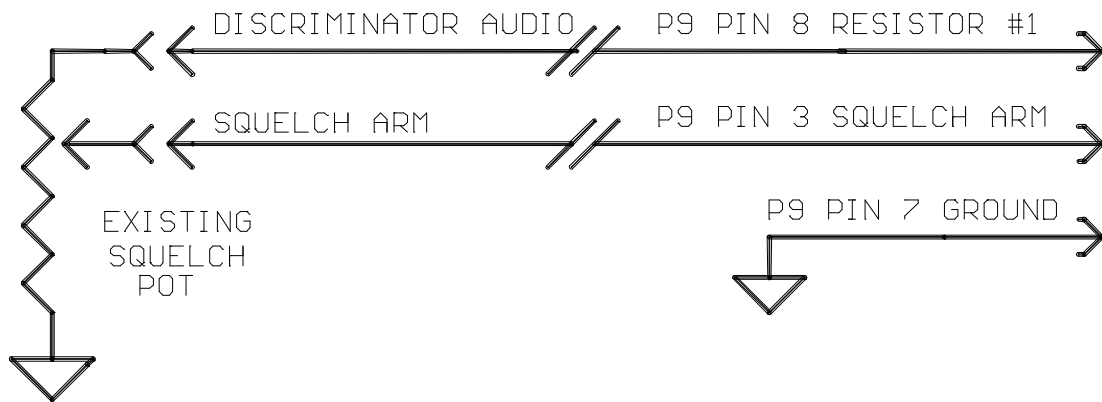

## ***Chapter 19: Tables, Drawings and Layouts***



## *Appendix A: ASCII Data Table*

This chart may be helpful when programming serial messages with Command 244. Not all of the codes are included because not all of them are universally used and some don't print well.

032	073 I	114 r	156 £	197 †	238 €
033 !	074 J	115 s	157 ¥	198 ‡	239 ∩
034 "	075 K	116 t	158 ₪	199 †	240 ≡
035 #	076 L	117 u	159 ₣	200 †	241 ±
036 \$	077 M	118 v	160 á	201 †	242 ≥
037 %	078 N	119 w	161 í	202 †	243 ≤
038 &	079 O	120 x	162 ó	203 †	244 ∫
039 '	080 P	121 y	163 ú	204 †	245 ∫
040 (	081 Q	122 z	164 ñ	205 =	246 ÷
041 )	082 R	123 {	165 Ñ	206 †	247 ≈
042 *	083 S	124	166 ª	207 †	248 °
043 +	084 T	125 }	167 °	208 †	249 ·
044 ,	085 U	126 ~	168 ¿	209 †	250 ·
045 -	086 V	128 Ç	169 ₠	210 †	251 √
046 .	087 W	129 ü	170 ¬	211 †	252 º
047 /	088 X	130 é	171 ½	212 †	253 ²
048 0	089 Y	131 â	172 ¼	213 †	254 ■
049 1	090 Z	132 ä	173 ¡	214 †	255
050 2	091 [	133 à	174 «	215 †	
051 3	092 \	134 å	175 »	216 †	
052 4	093 ]	135 ç	176 ☼	217 †	
053 5	094 ^	136 ê	177 ☼	218 †	
054 6	095 _	137 ë	178 ☼	219 ■	
055 7	096 `	138 è	179 †	220 ■	
056 8	097 a	139 ï	180 †	221 ■	
057 9	098 b	140 î	181 †	222 ■	
058 :	099 c	141 ì	182 †	223 ■	
059 ;	100 d	142 Ä	183 †	224 α	
060 <	101 e	143 Å	184 †	225 β	
061 =	102 f	144 É	185 †	226 Γ	
062 >	103 g	145 æ	186 †	227 π	
063 ?	104 h	146 Æ	187 †	228 Σ	
064 @	105 i	147 ô	188 †	229 σ	
065 A	106 j	148 ö	189 †	230 μ	
066 B	107 k	149 ò	190 †	231 τ	
067 C	108 l	150 û	191 †	232 Φ	
068 D	109 m	151 ù	192 †	233 Θ	
069 E	110 n	152 ÿ	193 †	234 Ω	
070 F	111 o	153 Ö	194 †	235 δ	
071 G	112 p	154 Ü	195 †	236 ∞	
072 H	113 q	155 ç	196 —	237 φ	

## *Appendix B: Tone Frequency Conversion Table*

Counts = (1,000,000 ÷ Frequency) - 1

Freq	Cnt
100	9999
105	9522
110	9089
115	8694
120	8332
125	7999
130	7691
135	7406
140	7141
145	6895
150	6665
155	6450
160	6249
165	6059
170	5881
175	5713
180	5554
185	5404
190	5262
195	5127
200	4999
205	4877
210	4760
215	4650
220	4544

225	4443
230	4346
235	4254
240	4165
245	4080
250	3999
255	3920
260	3845
265	3772
270	3702
275	3635
280	3570
285	3507
290	3447
295	3388
300	3332
305	3277
310	3224
315	3173
320	3124
325	3075
330	3029
335	2984
340	2940
345	2897
350	2856

355	2815
360	2776
365	2738
370	2701
375	2665
380	2630
385	2596
390	2563
395	2530
400	2499
405	2468
410	2438
415	2408
420	2379
425	2351
430	2324
435	2297
440	2271
445	2246
450	2221
455	2196
460	2172
465	2149
470	2126
475	2104
480	2082

485	2060
490	2039
495	2019
500	1999
505	1979
510	1959
515	1940
520	1922
525	1903
530	1885
535	1868
540	1850
545	1833
550	1817
555	1800
560	1784
565	1768
570	1753
575	1738
580	1723
585	1708
590	1693
595	1679
600	1665
605	1651
610	1638

615	1625
620	1611
625	1599
630	1586
635	1573
640	1561
645	1549
650	1537
655	1525
660	1514
665	1502
670	1491
675	1480
680	1469
685	1458
690	1448
695	1437
700	1427
705	1417
710	1407
715	1397
720	1387
725	1378
730	1368
735	1359
740	1350

745	1341
750	1332
755	1323
760	1314
765	1306
770	1297
775	1289
780	1281
785	1272
790	1264
795	1256
800	1249
805	1241
810	1233
815	1225
820	1218
825	1211
830	1203
835	1196
840	1189
845	1182
850	1175
855	1168
860	1161
865	1155
870	1148
875	1141
880	1135

885	1128
890	1122
895	1116
900	1110
905	1103
910	1097
915	1091
920	1085
925	1080
930	1074
935	1068
940	1062
945	1057
950	1051
955	1046
960	1040
965	1035
970	1029
975	1024
980	1019
985	1014
990	1009
995	1004
1000	999
1005	994
1010	989
1015	984
1020	979

1025	974
1030	969
1035	965
1040	960
1045	955
1050	951
1055	946
1060	942
1065	937
1070	933
1075	929
1080	924
1085	920
1090	916
1095	912
1100	908
1105	903
1110	899
1115	895
1120	891
1125	887
1130	883
1135	880
1140	876
1145	872
1150	868
1155	864
1160	861

1165	857
1170	853
1175	850
1180	846
1185	842
1190	839
1195	835
1200	832
1205	828
1210	825
1215	822
1220	818
1225	815
1230	812
1235	808
1240	805
1245	802
1250	799
1255	795
1260	792
1265	789
1270	786
1275	783
1280	780
1285	777
1290	774
1295	771
1300	768

1305	765
1310	762
1315	759
1320	756
1325	753
1330	750
1335	748
1340	745
1345	742
1350	739
1355	737
1360	734
1365	731
1370	728
1375	726
1380	723
1385	721
1390	718
1395	715
1400	713
1405	710
1410	708
1415	705
1420	703
1425	700
1430	698
1435	695
1440	693

1445	691
1450	688
1455	686
1460	683
1465	681
1470	679
1475	676
1480	674
1485	672
1490	670
1495	667
1500	665
1505	663
1510	661
1515	659
1520	656
1525	654
1530	652
1535	650
1540	648
1545	646
1550	644
1555	642
1560	640
1565	637
1570	635
1575	633
1580	631

1585	629
1590	627
1595	625
1600	624
1605	622
1610	620
1615	618
1620	616
1625	614
1630	612
1635	610
1640	608
1645	606
1650	605
1655	603
1660	601
1665	599
1670	597
1675	596
1680	594
1685	592
1690	590
1695	588
1700	587
1705	585
1710	583
1715	582
1720	580

1725	578
1730	577
1735	575
1740	573
1745	572
1750	570
1755	568
1760	567
1765	565
1770	563
1775	562
1780	560
1785	559
1790	557
1795	556
1800	554
1805	553
1810	551
1815	549
1820	548
1825	546
1830	545
1835	543
1840	542
1845	541
1850	539
1855	538
1860	536

1865	535
1870	533
1875	532
1880	530
1885	529
1890	528
1895	526
1900	525
1905	523
1910	522
1915	521
1920	519
1925	518
1930	517
1935	515
1940	514
1945	513
1950	511
1955	510
1960	509
1965	507
1970	506
1975	505
1980	504
1985	502
1990	501
1995	500
2000	499

2005	497
2010	496
2015	495
2020	494
2025	492
2030	491
2035	490
2040	489
2045	487
2050	486
2055	485
2060	484
2065	483
2070	482
2075	480
2080	479
2085	478
2090	477
2095	476
2100	475
2105	474
2110	472
2115	471
2120	470
2125	469
2130	468
2135	467
2140	466

2145	465
2150	464
2155	463
2160	461
2165	460
2170	459
2175	458
2180	457
2185	456
2190	455
2195	454
2200	453
2205	452
2210	451
2215	450
2220	449
2225	448
2230	447
2235	446
2240	445
2245	444
2250	443
2255	442
2260	441
2265	440
2270	439
2275	438
2280	437

2285	436
2290	435
2295	434
2300	433
2305	432
2310	431
2315	430
2320	430
2325	429
2330	428
2335	427
2340	426
2345	425
2350	424
2355	423
2360	422
2365	421
2370	420
2375	420
2380	419
2385	418
2390	417
2395	416
2400	415
2405	414
2410	413
2415	413
2420	412

2425	411
2430	410
2435	409
2440	408
2445	407
2450	407
2455	406
2460	405
2465	404
2470	403
2475	403
2480	402
2485	401
2490	400
2495	399
2500	399
2505	398
2510	397
2515	396
2520	395
2525	395
2530	394
2535	393
2540	392
2545	391
2550	391
2555	390
2560	389

2565	388
2570	388
2575	387
2580	386
2585	385
2590	385
2595	384
2600	383
2605	382
2610	382
2615	381
2620	380
2625	379
2630	379
2635	378
2640	377
2645	377
2650	376
2655	375
2660	374
2665	374
2670	373
2675	372
2680	372
2685	371
2690	370
2695	370
2700	369

2705	368
2710	368
2715	367
2720	366
2725	365
2730	365
2735	364
2740	363
2745	363
2750	362
2755	361
2760	361
2765	360
2770	360
2775	359
2780	358
2785	358
2790	357
2795	356
2800	356
2805	355
2810	354
2815	354
2820	353
2825	352
2830	352
2835	351
2840	351

2845	350
2850	349
2855	349
2860	348
2865	348
2870	347
2875	346
2880	346
2885	345
2890	345
2895	344
2900	343
2905	343
2910	342
2915	342
2920	341
2925	340
2930	340
2935	339
2940	339
2945	338
2950	337
2955	337
2960	336
2965	336
2970	335
2975	335
2980	334

2985	334
2990	333
2995	332
3000	332

## *Appendix C: Voice Word Look-up Table*

Custom word requests can be given to Link Communications for \$50.00 per word. The words will be added to the general word directory when purchased. Contact Link Communications Inc. for more information. (-F) Indicates The Female Voice

ZERO . . . . .	000	K . . . . .	040	AUTOMATIC . . . . .	080
ONE . . . . .	001	L . . . . .	041	AUXILIARY . . . . .	081
TWO . . . . .	002	M . . . . .	042	AVON . . . . .	082
THREE . . . . .	003	N . . . . .	043	A_M . . . . .	083
FOUR . . . . .	004	O . . . . .	044	BAND . . . . .	084
FIVE . . . . .	005	P . . . . .	045	BANK . . . . .	085
SIX . . . . .	006	Q . . . . .	046	BASE . . . . .	086
SEVEN . . . . .	007	R . . . . .	047	BATTERY . . . . .	087
EIGHT . . . . .	008	S . . . . .	048	BELOW . . . . .	088
NINE . . . . .	009	T . . . . .	049	BETWEEN . . . . .	089
TEN . . . . .	010	U . . . . .	050	BLOWING . . . . .	090
ELEVEN . . . . .	011	V . . . . .	051	BOARD . . . . .	091
TWELVE . . . . .	012	W . . . . .	052	BOZO . . . . .	092
THIRTEEN . . . . .	013	X . . . . .	053	BRAVO . . . . .	093
FOURTEEN . . . . .	014	Y . . . . .	054	BREAK . . . . .	094
FIFTEEN . . . . .	015	Z . . . . .	055	BROKEN . . . . .	095
SIXTEEN . . . . .	016	ABOUT . . . . .	056	BUSY . . . . .	096
SEVENTEEN . . . . .	017	ABOVE . . . . .	057	BUTTON . . . . .	097
EIGHTEEN . . . . .	018	ACKNOWLEDGE . . . . .	058	BY . . . . .	098
NINETEEN . . . . .	019	ACTION . . . . .	059	CALIBRATE . . . . .	099
TWENTY . . . . .	020	ADJUST . . . . .	060	CALL . . . . .	100
THIRTY . . . . .	021	ADVANCED . . . . .	061	CALLING . . . . .	101
FORTY . . . . .	022	ADVISE . . . . .	062	CALM . . . . .	102
FIFTY . . . . .	023	AIR . . . . .	063	CANCEL . . . . .	103
SIXTY . . . . .	024	AIRPORT . . . . .	064	CAUTION . . . . .	104
SEVENTY . . . . .	025	AKRON . . . . .	065	CELSIUS . . . . .	105
EIGHTY . . . . .	026	ALERT . . . . .	066	CENTER . . . . .	106
NINETY . . . . .	027	ALL . . . . .	067	CHANGE . . . . .	107
HUNDRED . . . . .	028	ALPHA . . . . .	068	CHARLIE . . . . .	108
THOUSAND . . . . .	029	AMATEUR . . . . .	069	CHECK . . . . .	109
A . . . . .	030	AMPS . . . . .	070	CIRCUIT . . . . .	110
B . . . . .	031	AND . . . . .	071	CLEAR . . . . .	111
C . . . . .	032	ANSWER . . . . .	072	CLOCK . . . . .	112
D . . . . .	033	APRIL . . . . .	073	CLOSED . . . . .	113
E . . . . .	034	AREA . . . . .	074	CLUB . . . . .	114
F . . . . .	035	AS . . . . .	075	CODE . . . . .	115
G . . . . .	036	ASSOCIATION . . . . .	076	COLUMBUS . . . . .	116
H . . . . .	037	AT . . . . .	077	COME . . . . .	117
I . . . . .	038	AUGUST . . . . .	078	COMPLETE . . . . .	118
J . . . . .	039	AUTO . . . . .	079	COMPUTER . . . . .	119

CONDITION	120	FAIL	167	HOLD	214
CONGRATULATN	121	FAILURE	168	HOME	215
CONNECT	122	FARAD	169	HOTEL	216
CONNECTICUT	123	FARENHEIT	170	HOUR	217
CONTACT	124	FAST	171	HOURS	218
CONTROL	125	FEBRUARY	172	ICE	219
COUNT	126	FEET	173	ICING	220
COURSE	127	FILED	174	IDENTIFY	221
CRANE	128	FINAL	175	IMMEDIATELY	222
CURRENT	129	FIRE	176	IN	223
CYCLE	130	FIRST	177	INCH	224
DALLAS	131	FLOW	178	INCREASE	225
DANGER	132	FOG	179	INCREASING	226
DATE	133	FOURTH	180	INDIA	227
DAY	134	FOXTROT	181	INDICATED	228
DAYS	135	FREEDOM	182	INFORMATION	229
DAYTON	136	FREEZING	183	INNER	230
DECEMBER	137	FREQUENCY	184	INSPECTOR	231
DECREASE	138	FRIDAY	185	INTRUDER	232
DECREASING	139	FROM	186	IS	233
DEGREES	140	FRONT	187	IT	234
DELTA	141	FULL	188	JANUARY	235
DEVICE	142	GATE	189	JULIET	236
DIAL	143	GAUGE	190	JULY	237
DINNER	144	GET	191	JUNE	238
DIRECTION	145	GO	192	KENTUCKY	239
DISPLAY	146	GOLF	193	KEY	240
DIVIDED	147	GOODBYE	194	KILO	241
DOOR	148	GREEN	195	LAND	242
DOWN	149	GREENWICH	196	LATE	243
DRIVE	150	GROUND	197	LEAN	244
DRIZZLE	151	GURNEE	198	LEFT	245
DUST	152	GUSTINGTO	199	LESSTHAN	246
EAST	153	HAIL	200	LEVEL	247
ECHO	154	HALF	201	LIGHT	248
ELECTRICIAN	155	HAM	202	LIMA	249
EMERGENCY	156	HAMFEST	203	LINE	250
ENGINE	157	HAMVENTION	204	LINK	251
ENTER	158	HAVE	205	LIST	252
EQUAL	159	HAZARDOUS	206	LITTON	253
EQUALS	160	HAZE	207	LOCK	254
ERROR	161	HEAVY	208	LONG	255
ESTIMATED	162	HELLO	209	LOOK	256
EVACUATE	163	HELP	210	LOW	257
EVACUATION	164	HENRY	211	LOWER	258
EXIT	165	HERTZ	212	LUNCH	259
EXPECT	166	HIGH	213	MACHINE	260



MAINTAIN	261	OHMS	308	RED	355
MANUAL	262	OIL	309	RELEASE	356
MARCH	263	ON	310	REMARK	357
MARKER	264	OPEN	311	REMOTE	358
MAY	265	OPERATION	312	REPAIR	359
MAYDAY	266	OPERATOR	313	REPEAT	360
ME	267	OSCAR	314	REPEATER	361
MEAN	268	OTHER	315	RICH	362
MEASURE	269	OUT	316	RICHMOND	363
MEETING	270	OUTER	317	RIG	364
MEGA	271	OVER	318	RIGHT	365
MESSAGES	272	OVERCAST	319	ROAD	366
METER	273	PAPA	320	ROGER	367
MICRO	274	PARTIALLY	321	ROMEO	368
MIKE	275	PASS	322	ROUTE	369
MILES	276	PASSED	323	SAFE	370
MILLI	277	PATCH	324	SAINT_PETERSBU	371
MINUS	278	PATH	325	SAND	372
MINUTES	279	PELLETS	326	SANTA_CLARA	373
MIST	280	PER	327	SAN_LEANDRO	374
MOBILE	281	PERCENT	328	SATURDAY	375
MODERATE	282	PHONE	329	SCATTERED	376
MONDAY	283	PLEASE	330	SECOND	377
MONTH	284	PLUS	331	SECONDS	378
MORETHAN	285	POINT	332	SECURITY	379
MOTOR	286	POLICE	333	SELECT	380
MOVE	287	POSITION	334	SEPTEMBER	381
MOVING	288	POWER	335	SEQUENCE	382
MUCH	289	PRACTICE	336	SERVICE	383
NEAR	290	PRESS	337	SET	384
NEGATIVE	291	PRESSURE	338	SEVERE	385
NET	292	PRIVATE	339	SEXY	386
NEW	293	PROBE	340	SHORT	387
NEWINGTON	294	PROGRAMMING	341	SHOWERS	388
NEXT	295	PULL	342	SHUT	389
NIGHT	296	PUSH	343	SIDE	390
NO	297	P_M	344	SIERRA	391
NORTH	298	QUEBEC	345	SIGHT	392
NOT	299	RADAR	346	SLEET	393
NOVEMBER	300	RADIO	347	SLOPE	394
NUMBER	301	RAIN	348	SLOW	395
OAKS	302	RAISE	349	SMOKE	396
OCLOCK	303	RANGE	350	SNOW	397
OCTOBER	304	RATE	351	SOUTH	398
OF	305	READY	352	SPEED	399
OFF	306	REAR	353	SPRAY	400
OHIO	307	RECEIVE	354	SQUAWK	401

START	402	UP	449	F-IS	496
STOP	403	USE(NOUN)	450	F-AM	497
STORM	404	USE(VERB)	451	F-PM	498
SUNDAY	405	VALLEY	452	F-OH	499
SWITCH	406	VALVE	453	F-OCLOCK	500
SYSTEM	407	VARIABLE	454	F-ONE	501
TANGO	408	VERIFY	455	F-TWO	502
TANK	409	VICTOR	456	F-THREE	403
TARGET	410	VISIBILITY	457	F-FOUR	504
TAXI	411	VOLTS	458	F-FIVE	505
TEEN	412	WAIT	459	F-SIX	506
TELEPHONE	413	WAKE	460	F-SEVEN	407
TEMPERATURE	414	WAKEUP	461	F-EIGHT	408
TERMINAL	415	WARNING	462	F-NINE	509
TEST	416	WATCH	463	F-TEN	510
THANKYOU	417	WATTS	464	F-ELEVEN	511
THAT	418	WAY	465	F-TWELVE	512
THE(LONGE)	419	WEATHER	466	F-THIRTEEN	513
THE(SHORTE)	420	WEDNESDAY	467	F-FOURTEEN	514
THE	421	WELCOME	468	F-FIFTEEN	515
THIN	422	WEST	469	F-SIXTEEN	516
THINLY	423	WHISKEY	470	F-SEVENTEEN	517
THIRD	424	WILL	471	F-EIGHTEEN	518
THIS-IS	425	WIND	472	F-NINETEEN	519
THIS	426	WISKEY	473	F-TWENTY	520
THUNDERSTORM	427	WITH	474	F-THIRTY	521
THURSDAY	428	WRONG	475	F-FORTY	522
TIME	429	X-RAY	476	F-FIFTY	523
TIMER	430	YANKEE	477	F-GOOD	524
TIMES	431	YELLOW	478	F-MORNING	525
TO	432	YESTERDAY	479	F-AFTERNOON	526
TODAY	433	YOU	480	F-EVENING	527
TOMORROW	434	YOUR	481	PAUSE	528
TONIGHT	435	ZED	482	#LASER	529
TOOL	436	ZONE	483	#WHISTLE	530
TORNADO	437	ZULU	484	#PHASER	531
TORONTO	438	FIF-	485	#TRAIN	532
TOUCHDOWN	439	THIR-	486	#EXP	533
TOWER	440	-ED	487	#CROWD	534
TRAFFIC	441	-ER	488	#TIC	535
TRANSMIT	442	-ING	489	#TOC	536
TUESDAY	443	-S	490	ALARM	537
TURN	444	-TEEN	491	ANALOG	538
UNDER	445	-TH	492	ARIZONA	539
UNIFORM	446	-TY	493	AUTOPATCH	540
UNIT	447	F-THE	494	BACHELOR	541
UNTIL	448	F-TIME	495	BAD	542

BAY .....	543	STAR .....	590	ANG 4 LOW DATE .	732
BILLINGS .....	544	STATE .....	591	VOICE POLITE ....	733
BOZEMAN .....	545	SUNDANCE .....	592	VOICE POLITE 1 ...	734
CANOE .....	546	TACOMA .....	593	SM.DVR SLOT 01 ..	735
CAPROCK .....	547	TIGER .....	594	SM.DVR SLOT 02 ..	736
CENTRAL .....	548	VALUE .....	595	SM.DVR SLOT 03 ..	737
CHARGING .....	549	VOLTAGE .....	596	SM.DVR SLOT 04 ..	738
CLOUDS .....	550	WASHINGTON ....	597	SM.DVR SLOT 05 ..	739
COMUNICATIONS ..	551	WATER .....	598	SM.DVR SLOT 06 ..	740
CONTROLLER ....	552	YAKIMA .....	599	SM.DVR SLOT 07 ..	741
DIGITAL .....	553	YELLOWHEAD ....	600	SM.DVR SLOT 08 ..	742
EMPIRE .....	554	YELLOWKNIFE ...	601	SM.DVR SLOT 09 ..	743
EVENT .....	555	<b>Execute a Command .602</b>		SM.DVR SLOT 10 ..	744
FIELD .....	556			SM.DVR SLOT 11 ..	745
FLASH .....	557	Special Words:		SM.DVR SLOT 12 ..	746
FLOOD .....	558	GOOD M/A/E .....	700	SM.DVR SLOT 13 ..	747
FRIENDLY .....	559	MALE TIME .....	701	SM.DVR SLOT 14 ..	748
GOLDEN .....	560	FEMALE TIME ....	702	SM.DVR SLOT 15 ..	749
GREYCLIFF .....	561	MALE DATE .....	703	SM.DVR SLOT 16 ..	750
HARRISON .....	562	MALE DAY .....	704	SM.DVR SLOT 17 ..	751
HOLLEY .....	563	ANALOG 1 .....	705	SM.DVR SLOT 18 ..	752
INLAND .....	564	ANALOG 2 .....	706	SM.DVR SLOT 19 ..	753
INPUT .....	565	ANALOG 3 .....	707	SM.DVR SLOT 20 ..	754
INSIDE .....	566	ANALOG 4 .....	708	SM.DVR SLOT 21 ..	755
KOOTENAI .....	567	ANALOG 1 HIGH ..	709	SM.DVR SLOT 22 ..	756
LINK2 .....	568	ANALOG 2 HIGH ..	710	SM.DVR SLOT 23 ..	757
LITTLEROCK ....	569	ANALOG 3 HIGH ..	711	SM.DVR SLOT 24 ..	758
MEDIUM .....	570	ANALOG 4 HIGH ..	712	SM.DVR SLOT 25 ..	759
MICA .....	571	ANALOG 1 LOW ...	713	SM.DVR SLOT 26 ..	760
MONITOR .....	572	ANALOG 2 LOW ...	714	SM.DVR SLOT 27 ..	761
MOUNTAIN .....	573	ANALOG 3 LOW ...	715	SM.DVR SLOT 28 ..	762
OBED .....	574	ANALOG 4 LOW ...	716	SM.DVR SLOT 29 ..	763
OREGON .....	575	ANG 1 HIGH TIME .	717	SM.DVR SLOT 30 ..	764
OUTSIDE .....	576	ANG 2 HIGH TIME .	718	SM.DVR SLOT 31 ..	765
PEAK .....	577	ANG 3 HIGH TIME .	719	SM.DVR SLOT 32 ..	766
POUND .....	578	ANG 4 HIGH TIME .	720	SM.DVR SLOT 33 ..	767
PUMP .....	579	ANG 1 LOW TIME .	721	SM.DVR SLOT 34 ..	768
PYRAMID .....	580	ANG 2 LOW TIME .	722	Not Defined .....	769
RACES .....	581	ANG 3 LOW TIME .	723	DVR POLITE .....	770
RATTLESNAKE ...	582	ANG 4 LOW TIME .	724	DVR POLITE1 .....	771
RIDGE .....	583	ANG 1 HIGH DATE .	725	PUBLIC MAIL CK ..	772
SANDRA .....	584	ANG 2 HIGH DATE .	726		
SCAN .....	585	ANG 3 HIGH DATE .	727		
SIDNEY .....	586	ANG 4 HIGH DATE .	728		
SKYWARN .....	587	ANG 1 LOW DATE .	729		
SOCIETY .....	588	ANG 2 LOW DATE .	730		
SPOKANE .....	589	ANG 3 LOW DATE .	731		

## *Special Voice Words*

Special voice words begin at 700. These words do special functions like read the time, day, date, analog channels with high/lows.

Special words 733 and 734 control how a voice message is handled. When the voice encounters either of these 2 words it will watch the calling channel and quit speaking if interrupted. When interrupted the voice will either quit speaking, or it will quit speaking and fetch an event (See command 063,064,065). This fetched event can contain a special CW message for ID's, voice interruption messages, and alike. This word can be located anywhere in the voice message.

Special words 770 and 771 control how a DVR message is handled. When the DVR encounters either of these 2 words it will watch the calling channel and quit speaking if interrupted. When interrupted the DVR will either quit speaking, or it will quit speaking and fetch an event (See command 063,064,065). This fetched event can contain a special CW message for ID's, DVR interruption messages, and alike. This word can be located anywhere in the DVR message.

Special word 772 recalls the DVR public mail waiting (See Command 068 in the DVR chapter). When this message is requested the DVR will either be silent if there is no mail or will speak "There is mail for ...."

Special word 602 allows execution of a command with a voice message. This is useful in synchronization of commands with words. Applications of this special word include link on\off messages, starting an external cart machine, toggling output lines on\off with the voice synthesizer and the list goes on... The format for this command is as follows: Word 602 must be followed by a 3 digit command number ranging between 000 and 245. This command number will be executed when the voice synthesizer reaches it.

## *Appendix D: Hardware*



LINK COMMUNICATIONS C.O. 1993  
RLC-2A REPEATER/LINK CONTROLLER

(XOYE)

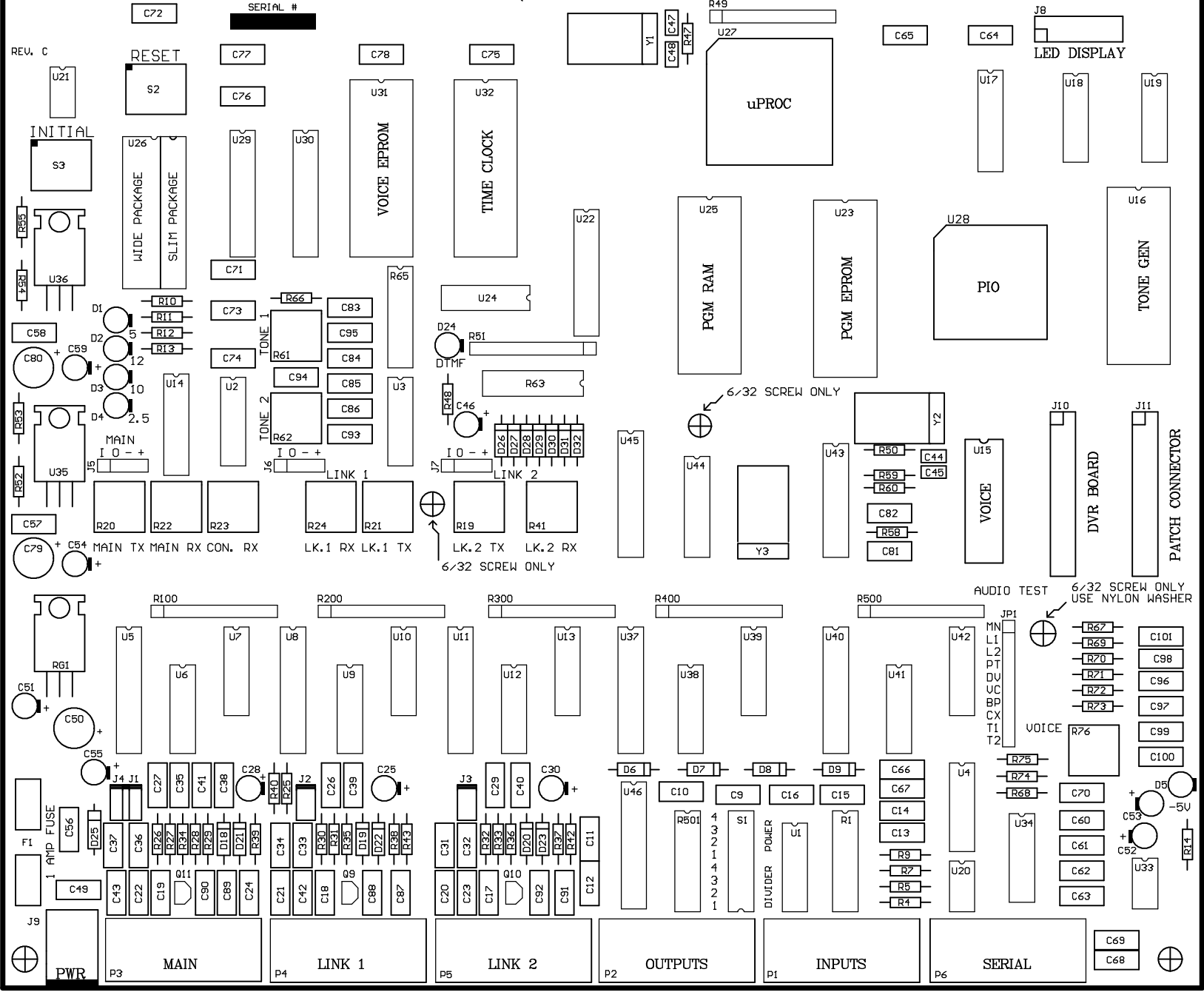

TELEPHONE INTERCONNECT OPTION  
LINK COMMUNICATIONS 1994

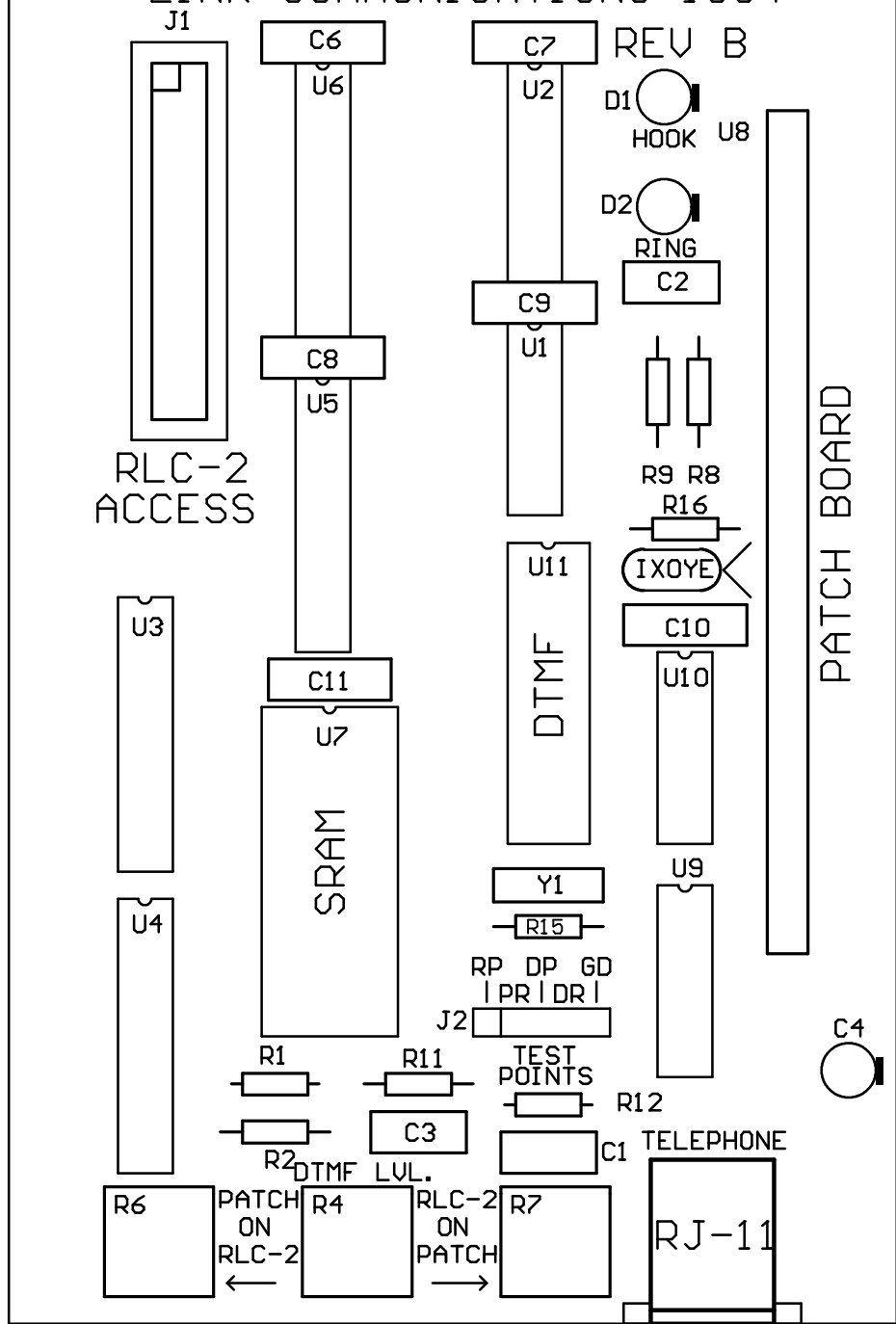

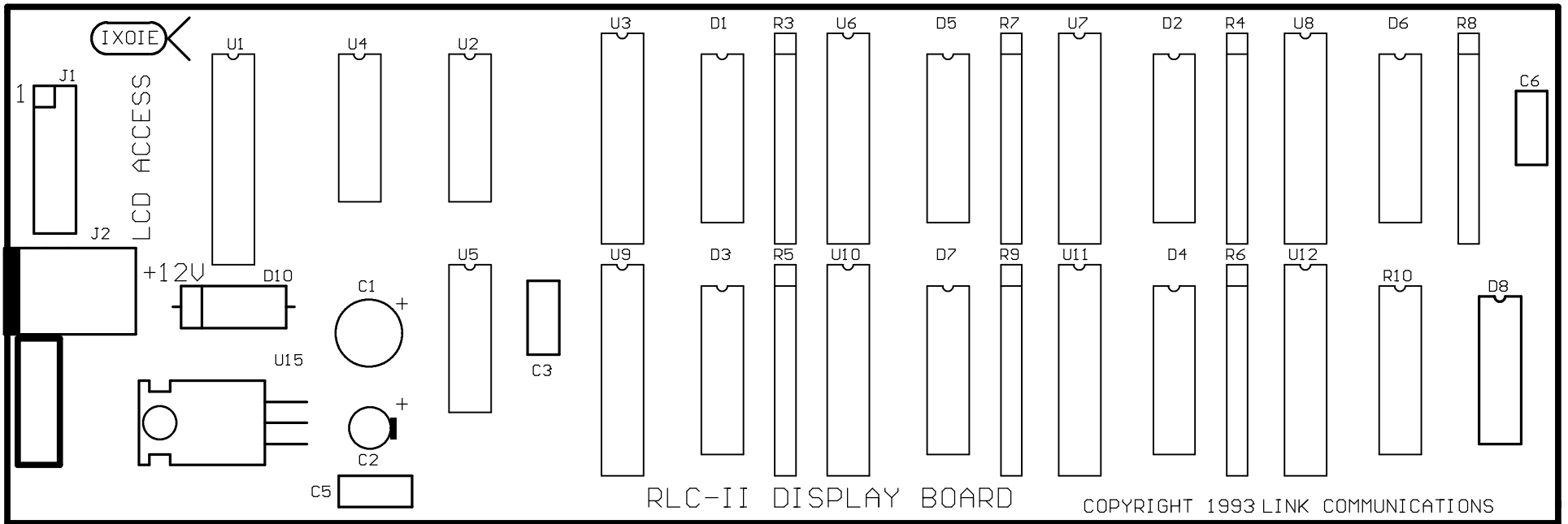



Digital Voice Recorder Rev. A  
Link Communications Inc. © 1995

SERIAL # [REDACTED]

IXOYE

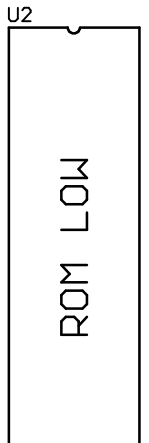
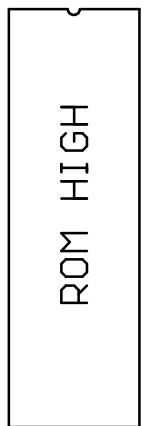
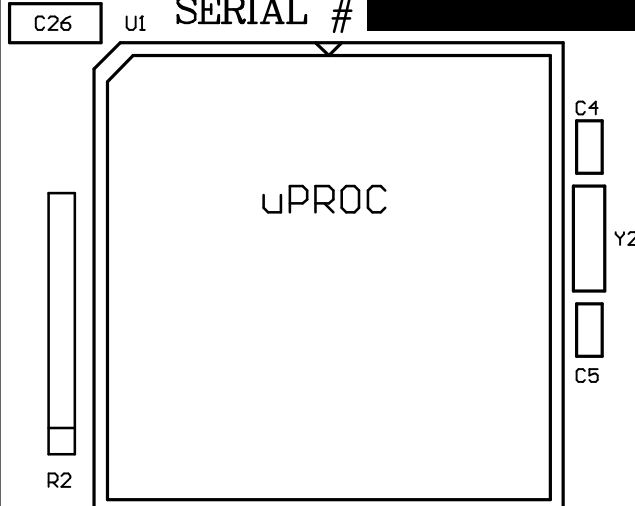

RAM #2 HIGH

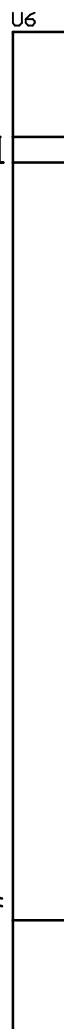

RAM #2 LOW

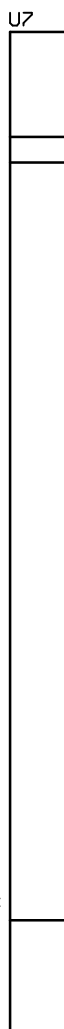

RAM #1 HIGH

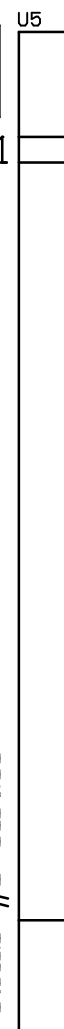

RAM #1 LOW

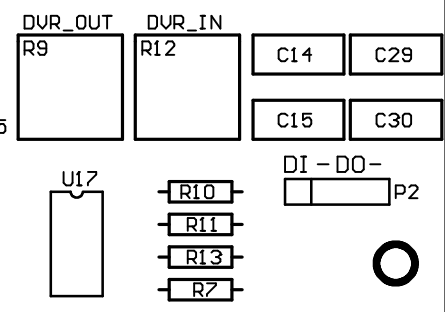
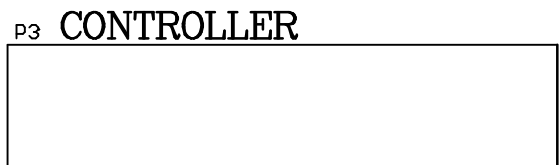
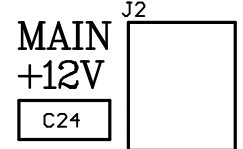
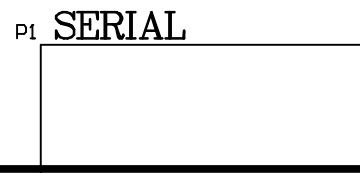
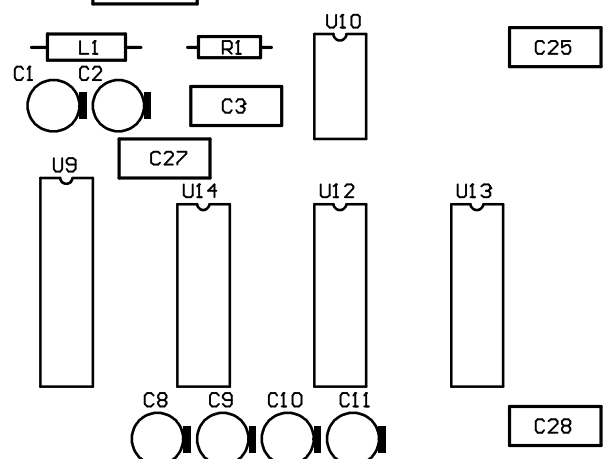
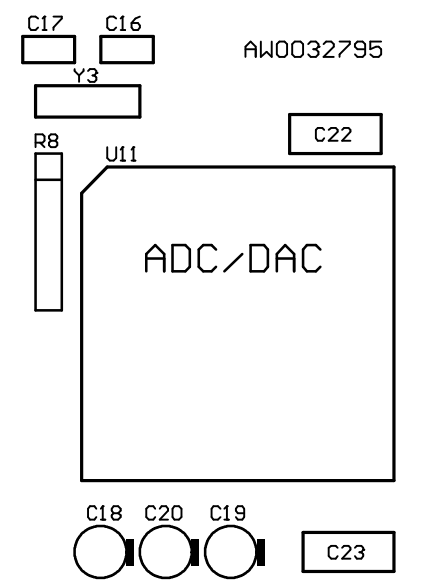
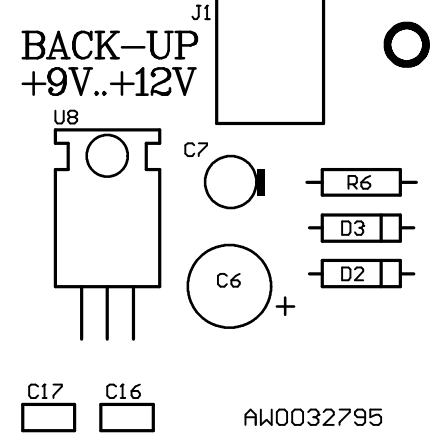
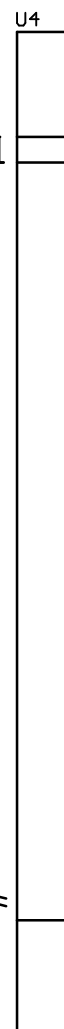

AW0032795

C22

C23

C28

C24

U16

U15

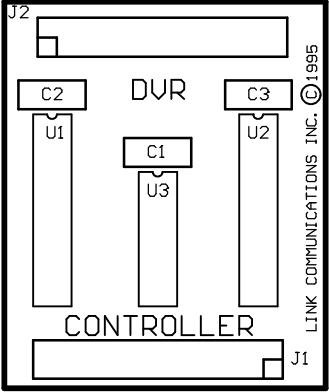

# 75 SECOND DIGITAL VOICE INTERFACE

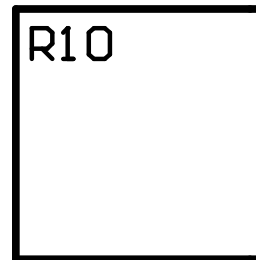
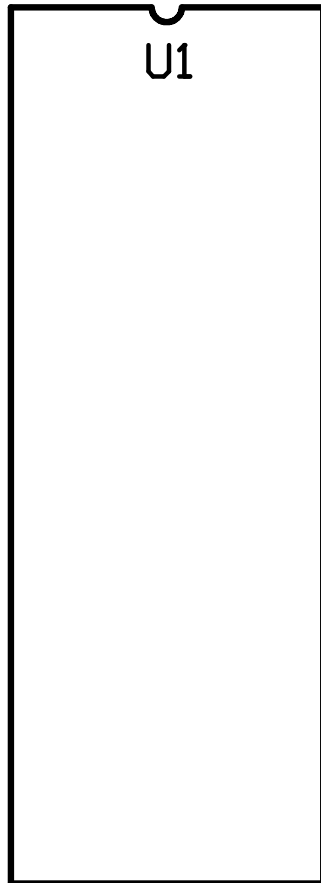
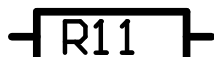
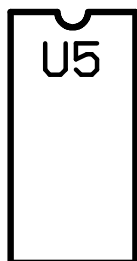
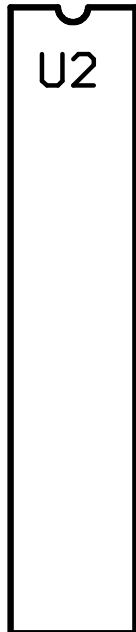
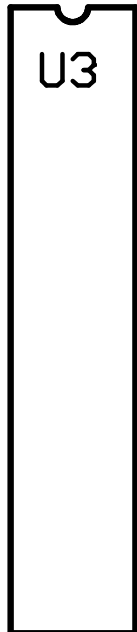
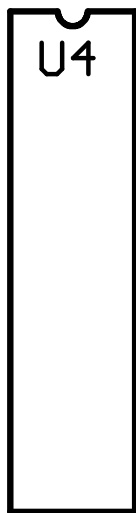

INPUT

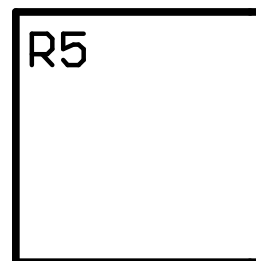

OUTPUT

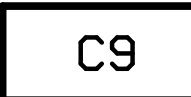
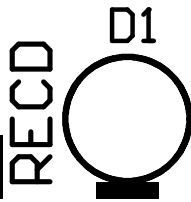
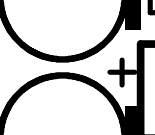
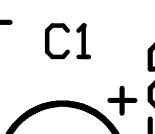
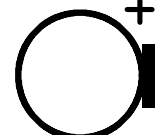

LINK COMM. INC. © 1996



REV. A

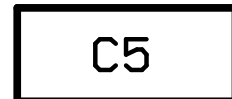
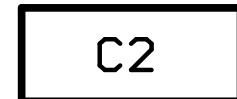

RECD  
PLAY

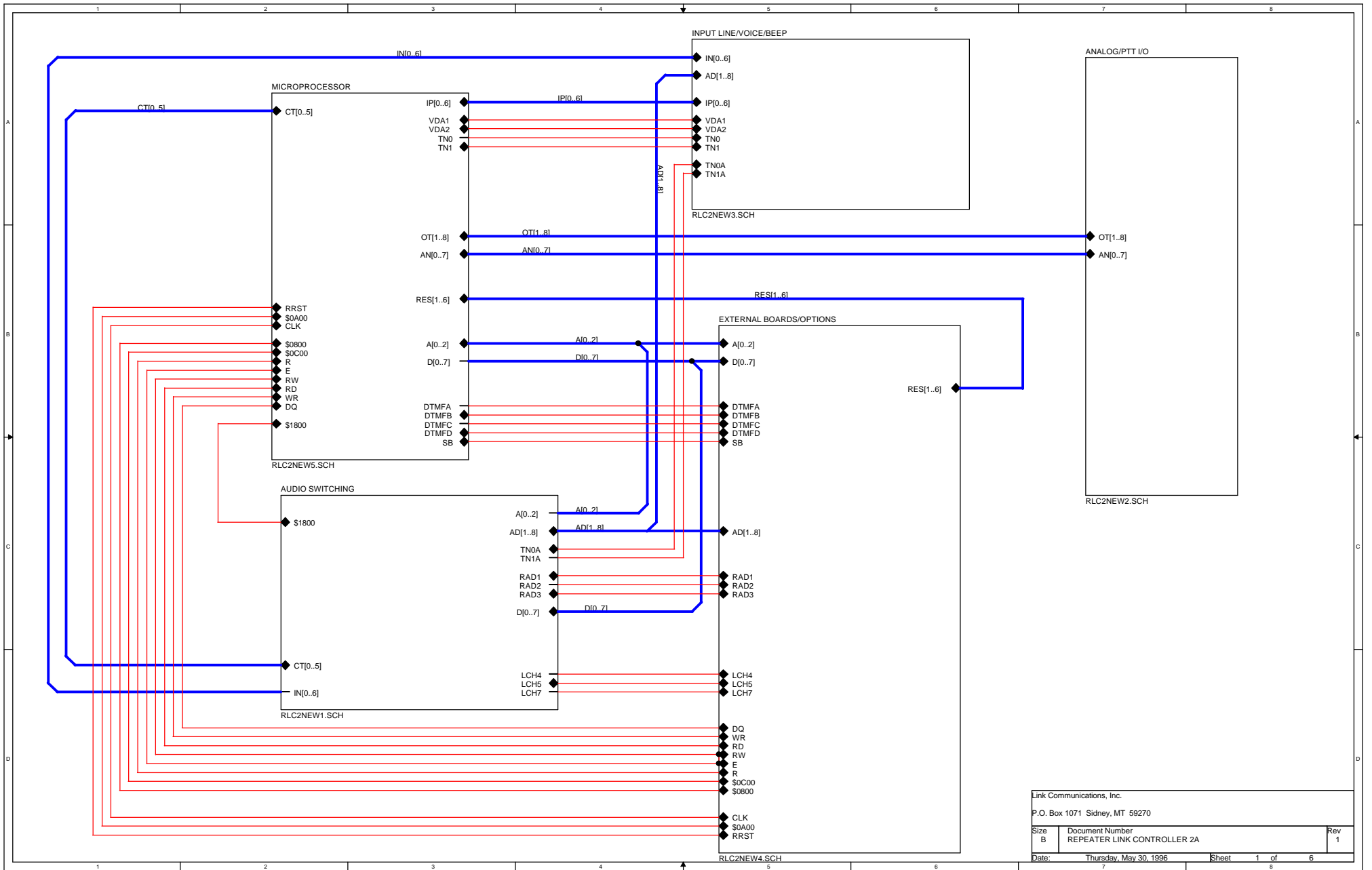

SHEET 1

MAIN

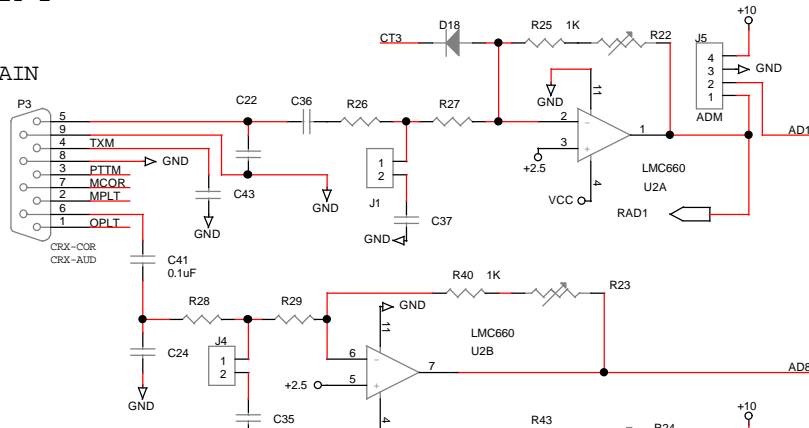

LINK 1

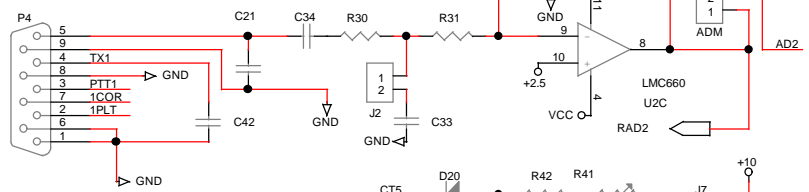

LINK 2

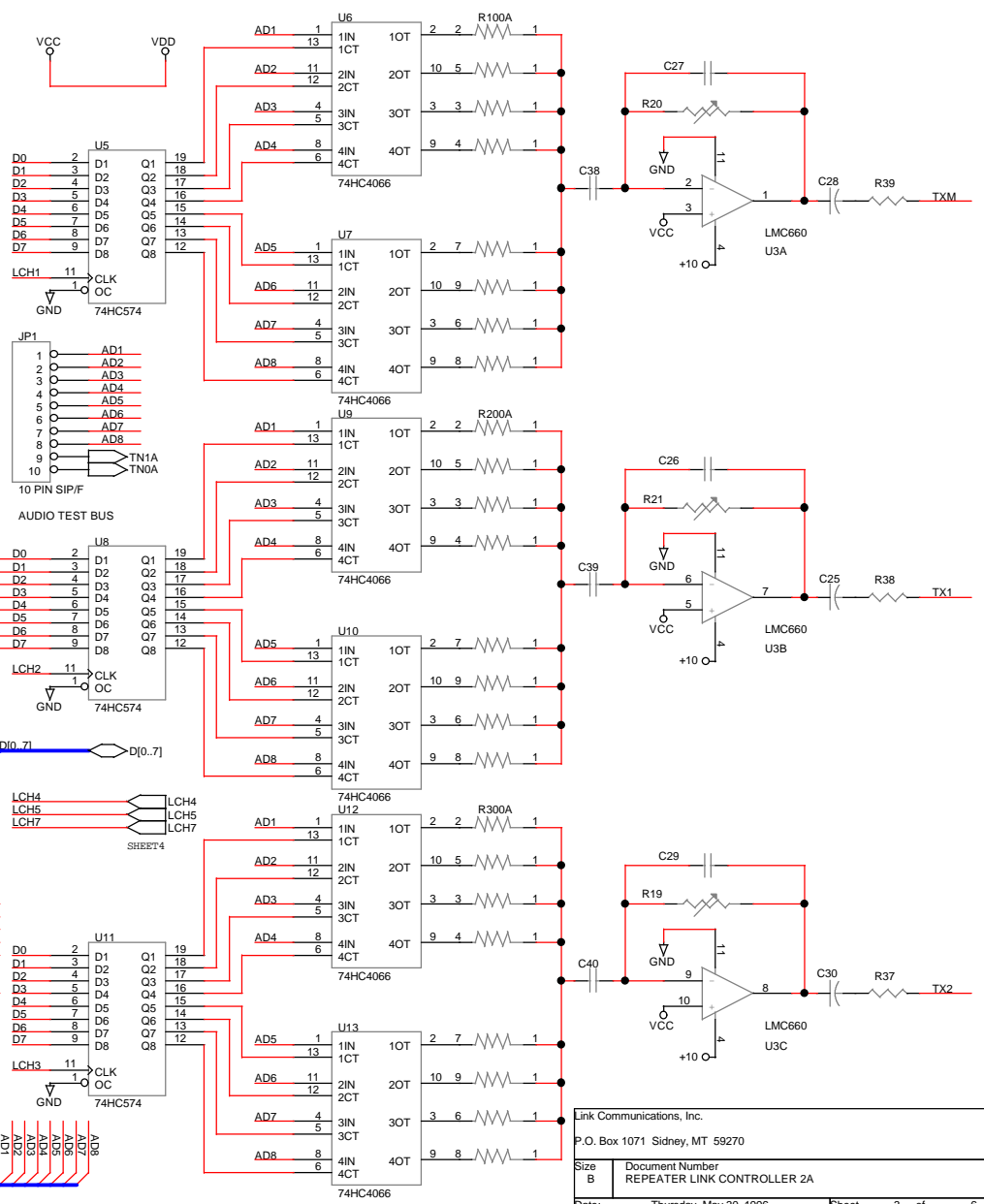
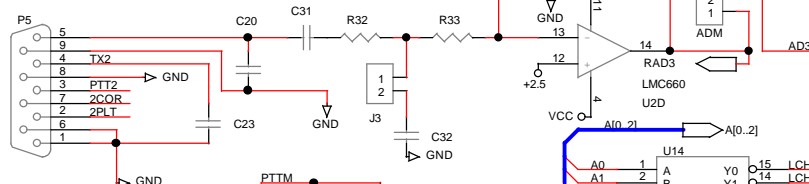

SHEET 3  
 SHEET 5

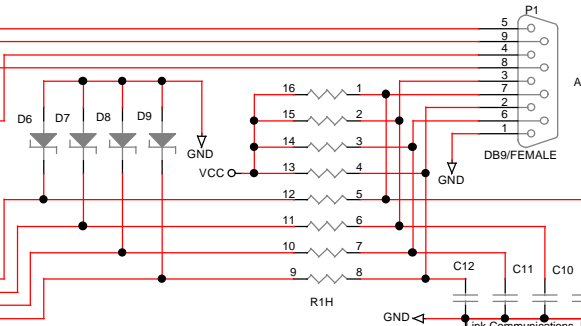
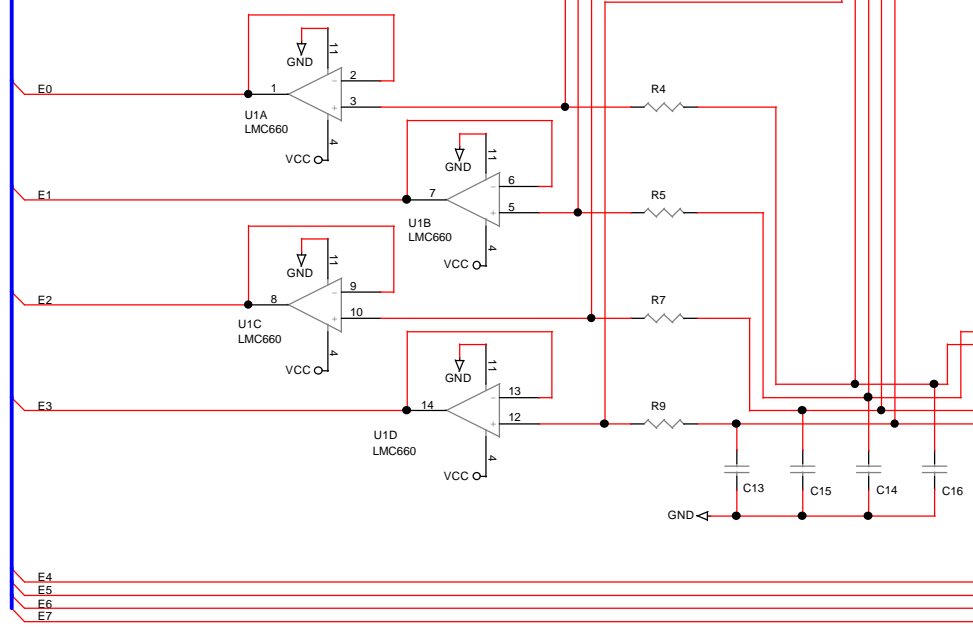
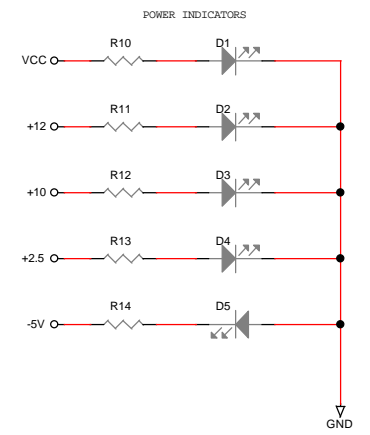
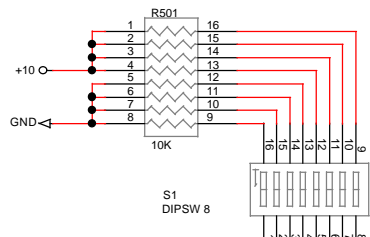
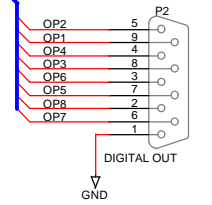
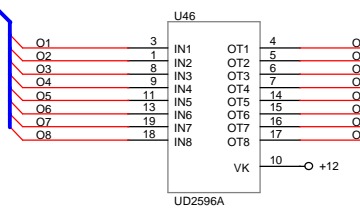

USER INPUT/OUTPUT/ANALOG I/O  
LINK COMMUNICATIONS REPEATER/LINK CONTROLLER 2A

SHEET 3

### TONE TWIST BALANCE

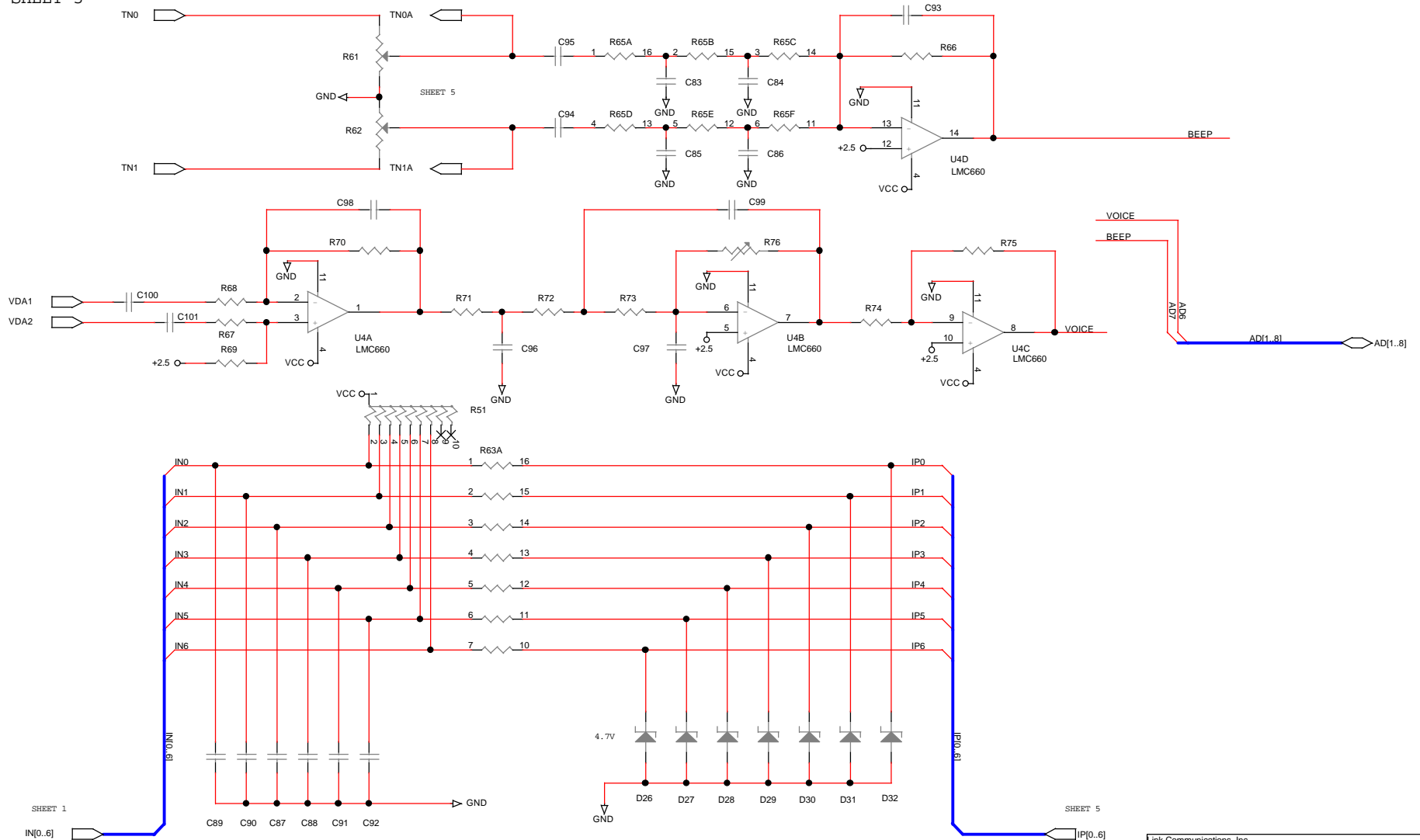

SHEET 1

IN[0..6]

SHEET 5

IP[0..6]

Link Communications, Inc.		
P.O. Box 1071 Sidney, MT 59270		
Size	Document Number	Rev
B	REPEATER LINK CONTROLLER 2A	1
Date:	Thursday, May 30, 1996	Sheet 6 of 6

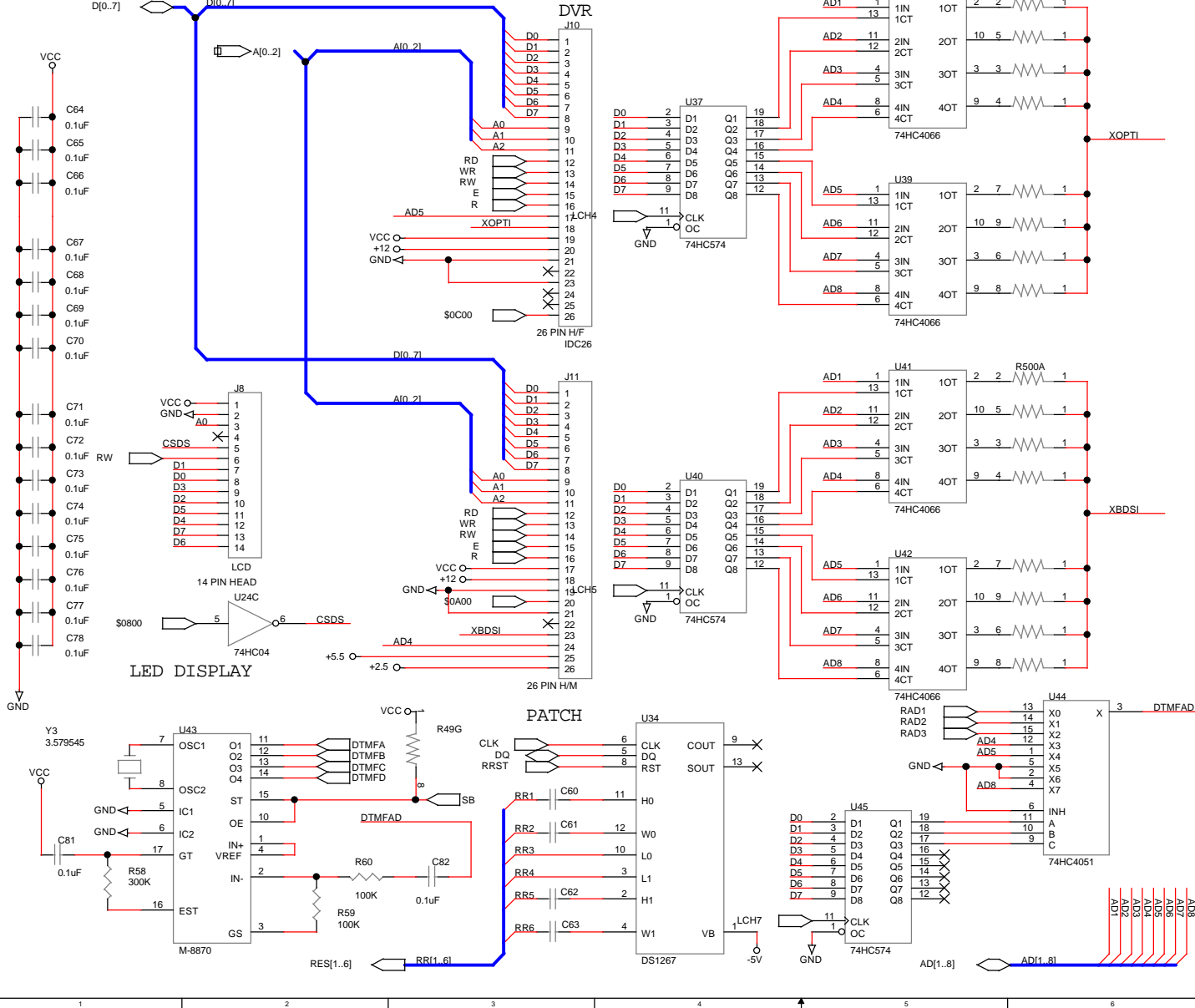

POWER SUPPLY

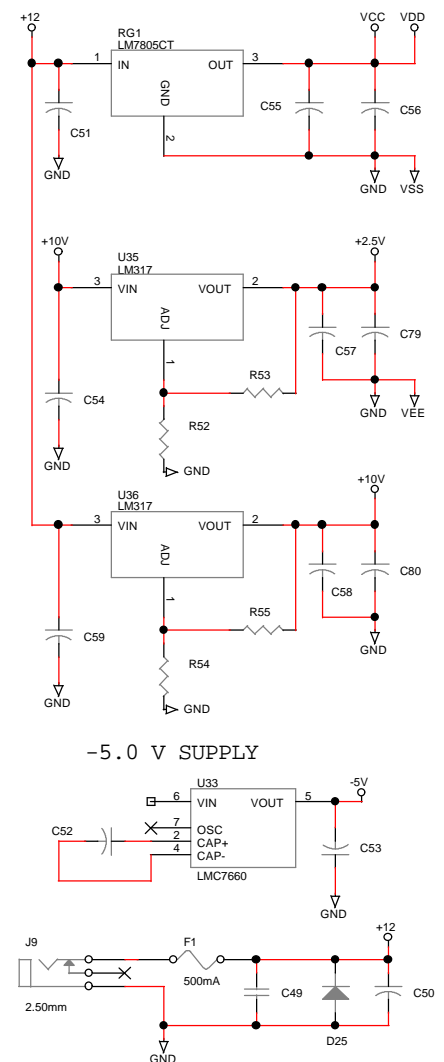



# MICROPROCESSOR SECTION

SHEET 5

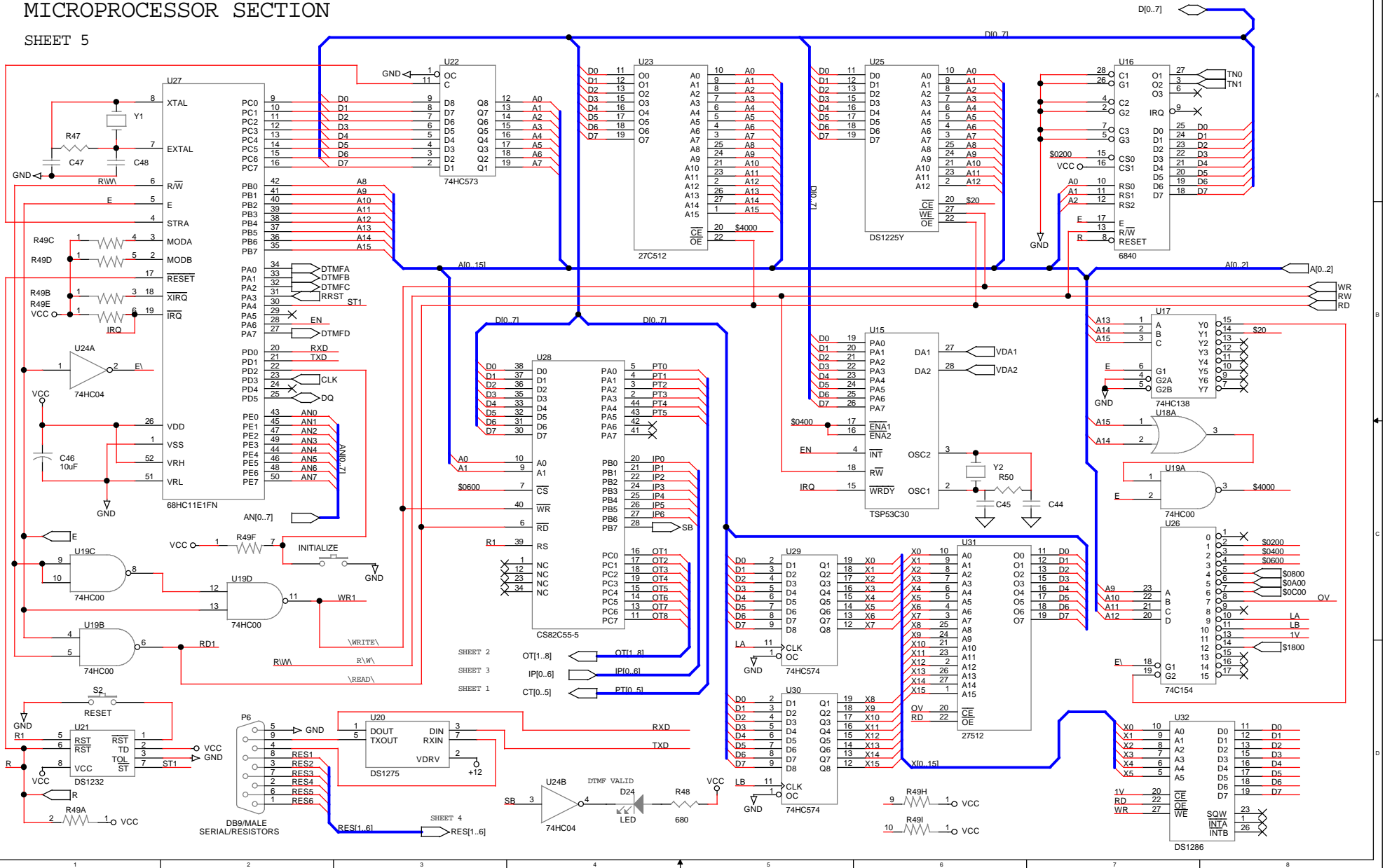

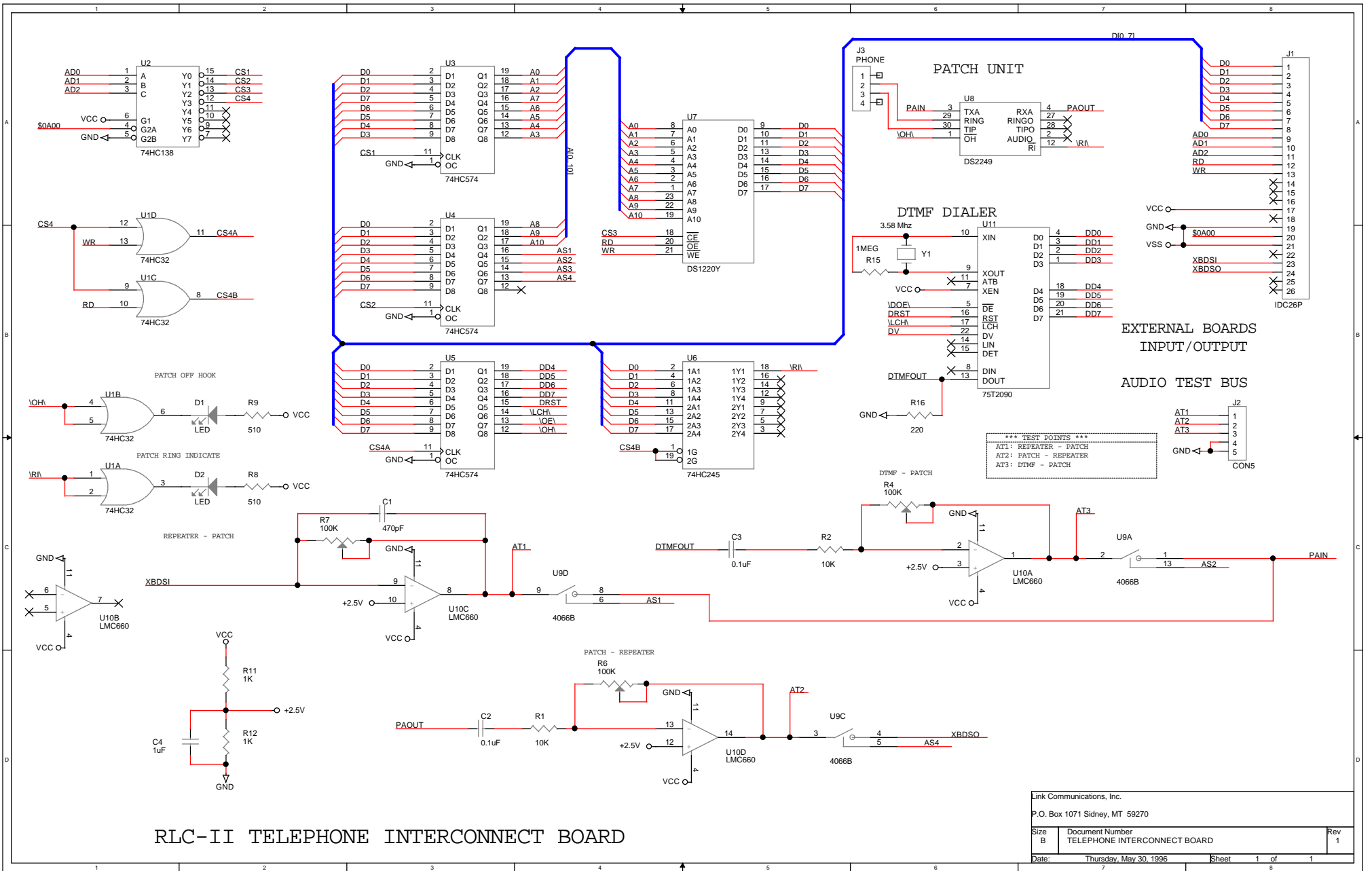

DVR PROCESSOR/MEMORY

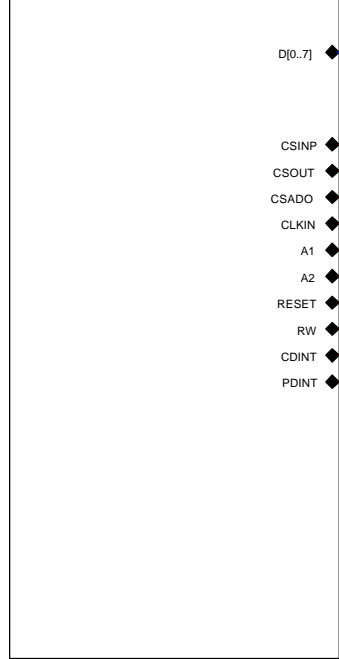

DVR1.SCH

DVR AUDIO INTERFACE

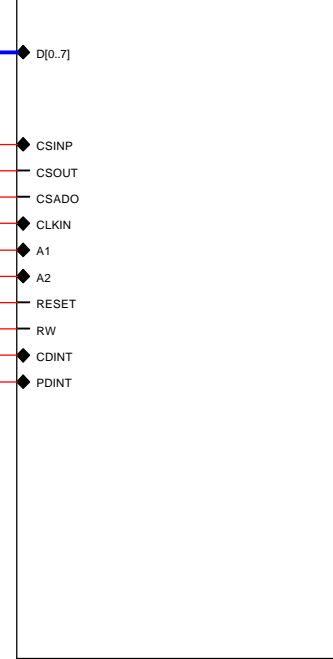

DVR2.SCH



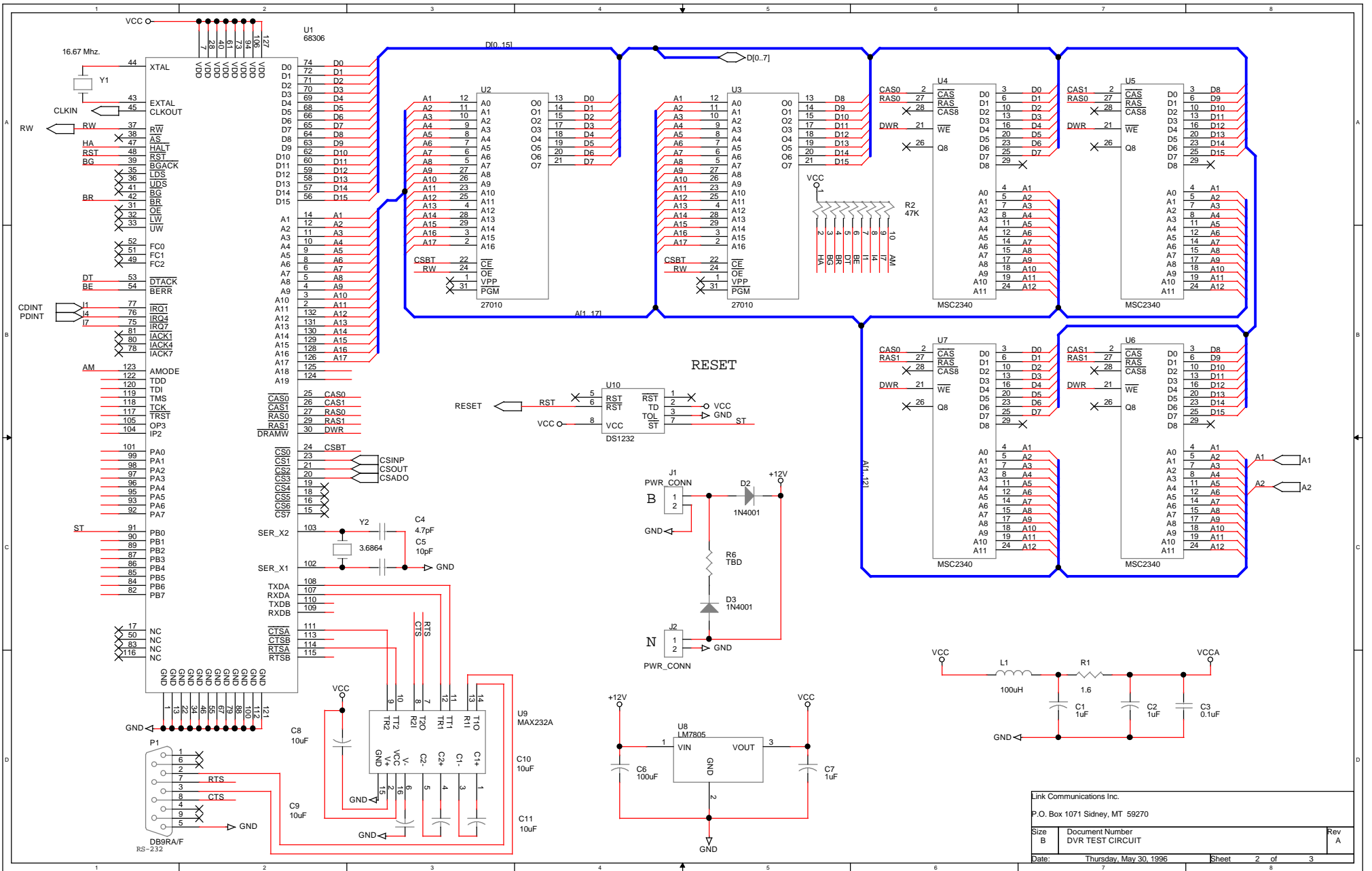

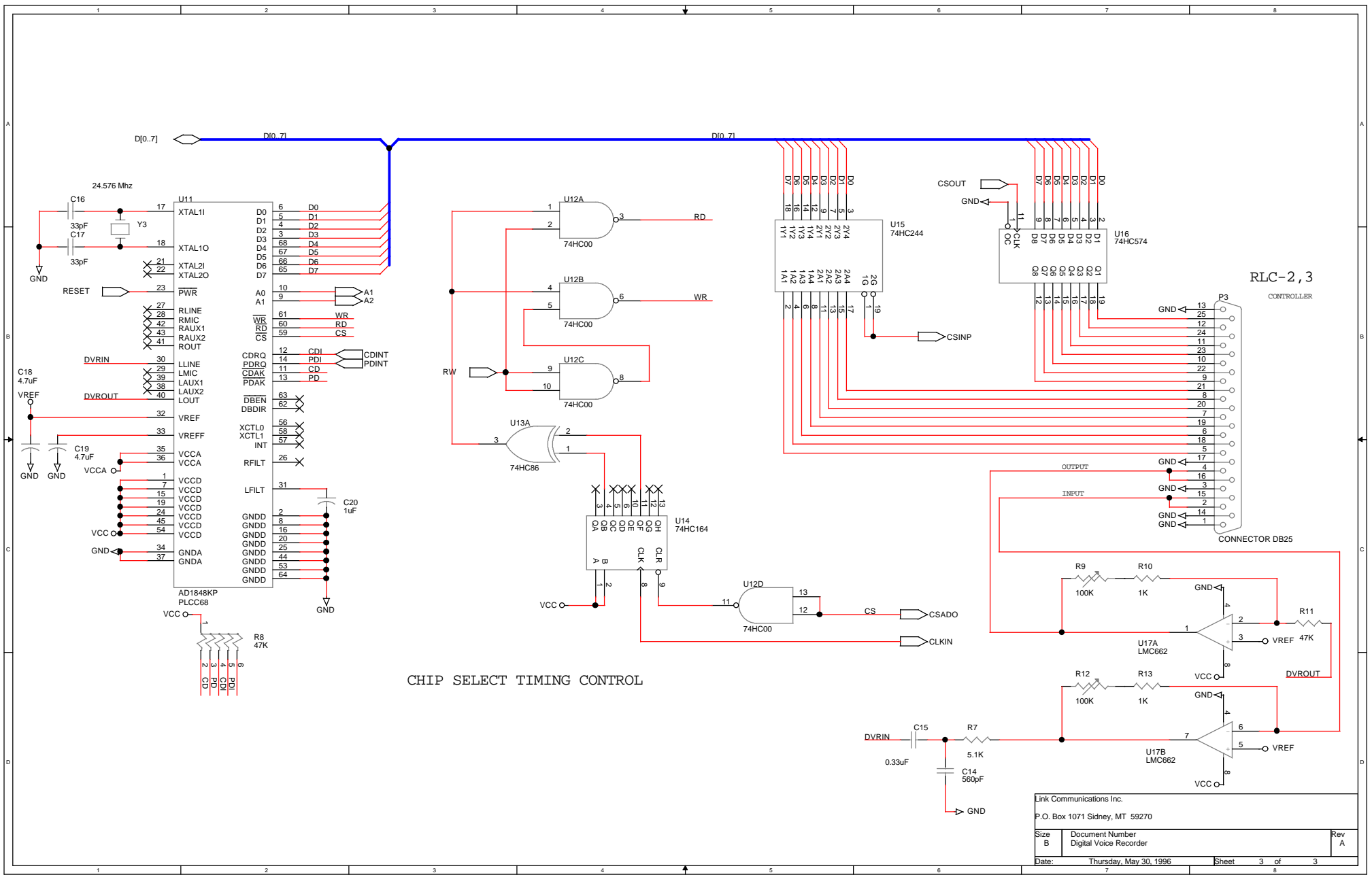

CHIP SELECT TIMING CONTROL

RLC-2, 3  
CONTROLLER

CONNECTOR DB25

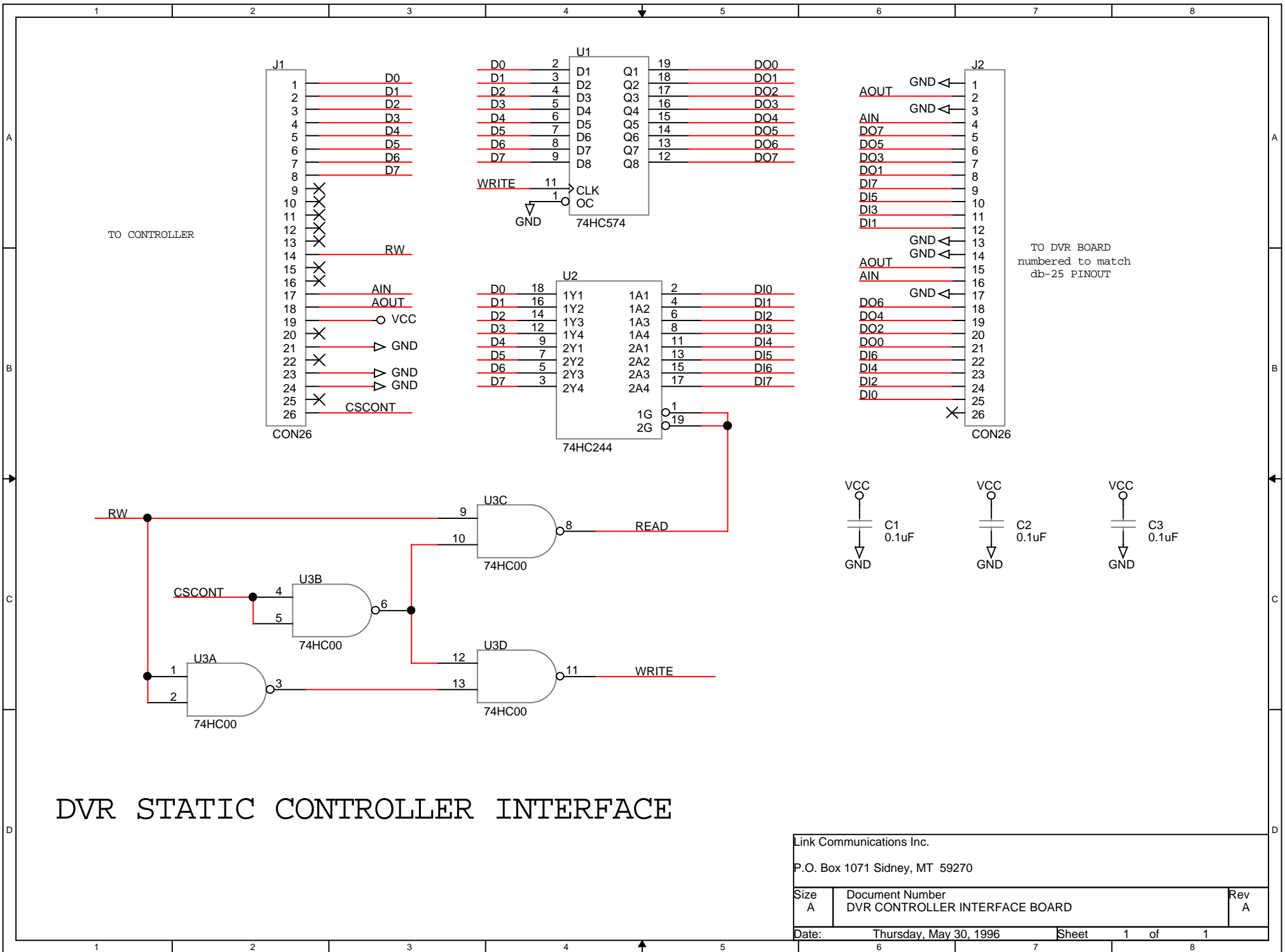

CONTROLLER

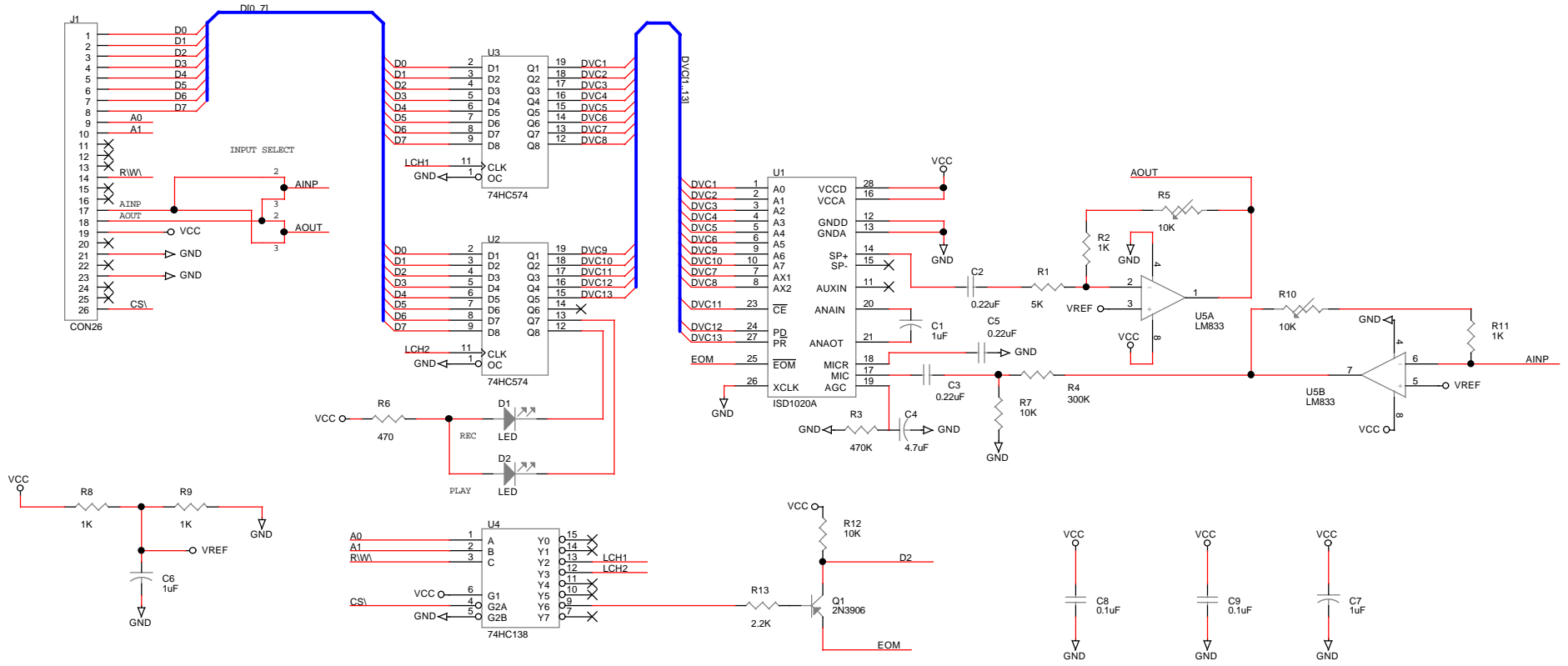

75 SECOND, 35 SLOT DVR INTERFACE

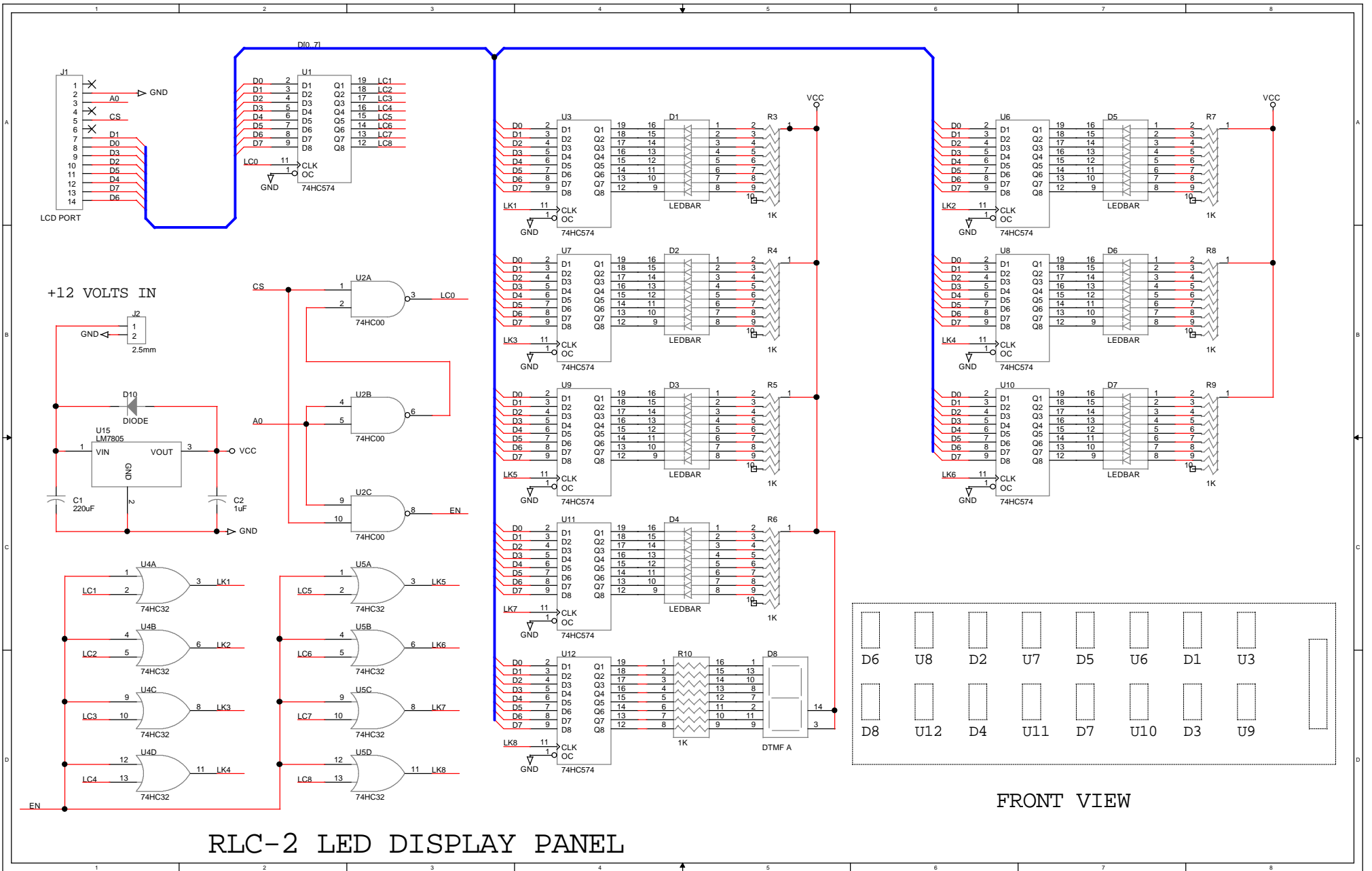



# *Bill of Materials*

**Bill of Materials**

Item	Quantity	Reference	Part
1	25 . . . .	C9,C10,C11,C12,C13,C14, C15,C16,C17,C18,C19,C20, C21,C22,C23,C24,C42,C43, C49,C87,C88,C89,C90,C91, C92	470pF
2	3	C25,C28,C30	4.7uF
3	5	C26,C27,C29,C93,C98	100pF
4	36 . . . . .	C31,C32,C33,C34,C35,C36, C37,C38,C39,C40,C41,C60, C61,C62,C63,C64,C65,C66, C67,C68,C69,C70,C71,C72, C73,C74,C75,C76,C77,C78, C81,C82,C94,C95,C100,C101	0.1uF
5	2	C44,C45	33pF
6	3	C46,C52,C53	10uF
7	2	C47,C48	22pF
8	1	C50	220uF
9	4	C51,C54,C55,C59	1uF
10	8 .	C56,C57,C58,C83,C84,C85, C86,C99	0.01uF
11	2	C79,C80	100uF
12	1	C96	2000pF
13	1	C97	68pF
14	6	D1,D2,D3,D4,D5,D24	LED
15	11 .	D6,D7,D8,D9,D26,D27,D28, D29,D30,D31,D32	1N750A
16	3	D18,D19,D20	1N4148
17	3	D21,D22,D23	1N5256B
18	1	D25	1N4001
19	1	F1	500mA Fuse
20	1	JP1	10 PIN Female Test Bus

**Bill of Materials**

Item	Quantity	Reference	Part
21	4	J1,J2,J3,J4	2 PIN HEAD/MALE
22	3	J5,J6,J7	4 PIN HEAD/MALE
23	1	J8	14 PIN HEAD
24	1	J9	2.50mm
25	1	J10	26 PIN H/F
26	1	J11	26 PIN H/M
27	5	P1,P2,P3,P4,P5	DB9/FEMALE
28	1	P6	DB9/MALE
29	3	Q9,Q10,Q11	2N7000
30	1	RG1	LM7805CT
31	2	R1,R63	16 PIN DIP/1K
32	4	R4,R5,R7,R9	40.2K
33	3	R10,R12,R14	510
34	6	R11,R25,R40,R42,R43,R7	41K
35	1	R13	270
36	9 .	R19,R20,R21,R23,R59,R60, R61,R62,R66	100K
37	3	R22,R24,R41	200K
38	8 .	R26,R27,R28,R29,R30,R31, R32,R33	5K
39	8 .	R34,R35,R36,R69,R73,R75, R76,R501	10K
40	4	R37,R38,R39,R48	680
41	1	R47	10M
42	1	R49	10 PIN SIP/47K
43	1	R50	1M
44	1	R51	10 PIN SIP/1K

**Bill of Materials**

Item	Quantity	Reference	Part
45	3	R52,R53,R55	237
46	1	R54	1.69K
47	1	R58	470K
48	1	R63	16 PIN SIP/1K
49	1	R65	33K
50	2	R67,R68	24.9K
51	8 .	R70,R71,R72,R100,R200, R300,R400,R500	47K
52	1	S1	DIPSW8
53	2	S2,S3	PUSH BUTTON SWITCH
54	4	U1,U2,U3,U4	LMC660
55	8 .	U5,U8,U11,U29,U30,U37, U40,U45	74HC574
56	10 .	U6,U7,U9,U10,U12,U13,U38, U39,U41,U42	74HC4066
57	2	U17,U14 74HC138	
58	1	U15	TSP53C30
59	1	U16	6840
60	1	U18	74HC32
61	1	U19	74HC00
62	1	U20	DS1275
63	1	U21	DS1232
64	1	U22	74HC573
65	1	U23	27C512
66	1	U24	74HC04
67	1	U25	DS1225Y
68	1	U26	74C154

**Bill of Materials**

Item	Quantity	Reference	Part
69	1	U27	68HC11E1FN
70	1	U28	CS82C55-5
71	1	U31	27512
72	1	U32	DS1286
73	1	U33	LMC7660
74	1	U34	DS1267
75	2	U35,U36 LM317	
76	1	U43	M-8870
77	1	U44	74HC4051
78	1	U46	UDN2597A
79	1	Y1	8.00 Mhz
80	1	Y2	3.2768 Mhz
81	1	Y3	3.579545 Mhz
82	1	Manual	Users Manual
83	1	PC Board	4 Layer PC Board
84	1	Parts Bag	5 Female DB-9, 1 Male DB-9, 1 2.5mm Power