

# 9800 Series

LTR<sup>®</sup> MOBILE

## SERVICE MANUAL

### 984X SERIES (UHF) 988X SERIES (800 MHz) 989X SERIES (900 MHz) 98XX SERIES (DATA)

### LTR<sup>®</sup> MOBILE

25 or 40 Watts (UHF); 15 or 30 Watts (800/900 MHz)

13.6 VDC

Part No. 242-98xx-2xx



Low Tier



High Tier



Remote-Mount  
High-Tier



Second Issue

April 2001

Supersedes: Part No. 001-9800-200; 9/99



# **98xx-SERIES FM TWO-WAY RADIO SERVICE MANUAL**

**13.6 VDC**

**25 or 40 Watts, UHF**

**15 or 30 Watts, 800/900 MHz**

**Part No. 242-984x-2xx (UHF)**

**Part No. 242-988x-2xx (800 MHz)**

**Part No. 242-989x-2xx (900 MHz)**

Copyright © 2001 by the E.F. Johnson Company

The E.F. Johnson Company, which was founded in 1923, provides wireless communication systems solutions for public safety, government, and commercial customers. The company designs, manufactures, and markets conventional and trunked radio systems, mobile and portable subscriber radios, repeaters, and Project 25 digital radio products.

Viking Head/EFJohnson logo, LTR<sup>®</sup>, LTR-Net<sup>™</sup>, Multi-Net<sup>®</sup>, and Call Guard<sup>®</sup> are trademarks of the E.F. Johnson Company. SMARTNET<sup>™</sup> and SmartZone<sup>®</sup> are trademarks of Motorola, Inc. All other company and/or product names used in this manual are trademarks and/or registered trademarks of their respective manufacturer.

Information in this manual is subject to change without notice.

TABLE OF CONTENTS

<p><b>1 GENERAL INFORMATION</b></p> <p><b>1.1 SCOPE OF MANUAL</b> . . . . . 1-1</p> <p><b>1.2 TRANSCEIVER DESCRIPTION</b> . . . . . 1-1</p> <p>    General . . . . . 1-1</p> <p>    Available Frequency Bands . . . . . 1-1</p> <p>    Low And High Tier Models . . . . . 1-1</p> <p>    Data Models . . . . . 1-2</p> <p>    Front and Remote Mounting . . . . . 1-2</p> <p>    NPSPAC Models (800 MHz Only) . . . . . 1-2</p> <p>    Programming . . . . . 1-3</p> <p>    Transceiver Alignment . . . . . 1-3</p> <p><b>1.3 PART NUMBER BREAKDOWN</b> . . . . . 1-3</p> <p><b>1.4 TRANSCEIVER IDENTIFICATION</b> . . . . . 1-3</p> <p><b>1.5 ACCESSORIES</b> . . . . . 1-4</p> <p><b>1.6 PRODUCT WARRANTY</b> . . . . . 1-5</p> <p><b>1.7 FACTORY CUSTOMER SERVICE</b> . . . . . 1-5</p> <p><b>1.8 FACTORY RETURNS</b> . . . . . 1-6</p> <p><b>1.9 REPLACEMENT PARTS</b> . . . . . 1-6</p> <p><b>1.10 INTERNET HOME PAGE</b> . . . . . 1-6</p> <p>    <b>UHF 984x SPECIFICATIONS</b> . . . . . 1-7</p> <p>    <b>800 MHz 988x SPECIFICATIONS</b> . . . . . 1-8</p> <p>    <b>900 MHz 989x SPECIFICATIONS</b> . . . . . 1-9</p> <p><b>2 INSTALLATION</b></p> <p><b>2.1 GENERAL</b> . . . . . 2-1</p> <p>    Scope of Instructions . . . . . 2-1</p> <p>    Performance Tests . . . . . 2-1</p> <p>    Transceiver Programming . . . . . 2-2</p> <p>    Required Power Source . . . . . 2-2</p> <p><b>2.2 MOUNTING THE TRANSCEIVER</b> . . . . . 2-2</p> <p>    Selecting A Mounting Location . . . . . 2-2</p> <p>    Installation Components . . . . . 2-2</p> <p>    Attaching Mounting Bracket . . . . . 2-2</p> <p><b>2.3 POWER CABLE INSTALLATION</b> . . . . . 2-3</p> <p><b>2.4 ACCESSORY CABLE INSTALLATION</b> . . . . . 2-4</p> <p>    General . . . . . 2-4</p> <p>    Accessory Pigtail Installation . . . . . 2-5</p> <p>    Connecting Ignition Sense Wire . . . . . 2-5</p> <p>    Connecting Horn Alert Wire . . . . . 2-6</p> <p>    Other Accessory Cable Outputs . . . . . 2-6</p> <p><b>2.5 REMOTE CONTROL UNIT INSTALLATION</b> . . . . . 2-6</p> <p>    General . . . . . 2-6</p> <p>    Mounting Remote Control Unit . . . . . 2-6</p> <p><b>2.6 USING AN EXTERNAL SPEAKER</b> . . . . . 2-7</p> <p><b>2.7 DATA CABLE INSTALLATION</b> . . . . . 2-7</p> <p>    General . . . . . 2-8</p> <p>    Data Cable Installation . . . . . 2-8</p> <p><b>2.8 KEY CAP KITS</b> . . . . . 2-8</p>	<p><b>3 OPERATION</b></p> <p><b>3.1 FEATURES</b> . . . . . 3-1</p> <p><b>3.2 CONTROLS</b> . . . . . 3-3</p> <p>    Low Tier Controls . . . . . 3-3</p> <p>    High Tier Controls and Indicator . . . . . 3-3</p> <p>    Rear Panel Jacks and Connectors . . . . . 3-4</p> <p><b>3.3 DISPLAY DESCRIPTION</b> . . . . . 3-4</p> <p>    Low Tier Display . . . . . 3-4</p> <p>    High Tier Display . . . . . 3-5</p> <p><b>3.4 GENERAL OPERATION</b> . . . . . 3-5</p> <p>    Power-Up Sequence . . . . . 3-5</p> <p>    Determining Volume Level . . . . . 3-5</p> <p>    Backlight Operation . . . . . 3-6</p> <p>    System/Group Display Information . . . . . 3-6</p> <p>    Selecting Systems And Groups . . . . . 3-6</p> <p>    Setting Squelch Control . . . . . 3-7</p> <p>    LTR and Conventional Operating Modes . . . . . 3-8</p> <p>    Placing and Receiving Standard (Dispatch) Calls . . . . . 3-9</p> <p>    Placing and Receiving Telephone Calls . . . . . 3-9</p> <p><b>3.5 GENERAL FEATURES</b> . . . . . 3-10</p> <p>    AUX (Auxiliary) Switch(es) . . . . . 3-10</p> <p>    Bank Select (High Tier Only) . . . . . 3-10</p> <p>    Call Indicator . . . . . 3-10</p> <p>    Companding . . . . . 3-11</p> <p>    Data System/Groups . . . . . 3-11</p> <p>    Emergency Switch (High Tier Only) . . . . . 3-11</p> <p>    Encryption . . . . . 3-11</p> <p>    Function Switch (High Tier Only) . . . . . 3-12</p> <p>    Home System/Group Select . . . . . 3-12</p> <p>    Horn Alert . . . . . 3-12</p> <p>    Option Select . . . . . 3-13</p> <p>    Power Turn-Off Delay . . . . . 3-13</p> <p>    Proceed (Clear-To-Talk) Tone . . . . . 3-14</p> <p>    Programmable Power Output . . . . . 3-14</p> <p>    Stealth Mode (High Tier Only) . . . . . 3-14</p> <p>    Time-Out Timer . . . . . 3-14</p> <p>    Tone Select . . . . . 3-15</p> <p>    Transmitter Thermal Foldback . . . . . 3-15</p> <p><b>3.6 OPTION SWITCHES AND MENU MODE</b> . . . . . 3-15</p> <p>    Using Option Switches . . . . . 3-15</p> <p>    Using Menu Mode . . . . . 3-15</p> <p>    Using Menu Mode . . . . . 3-17</p> <p>    A/D (Scan List Programming) . . . . . 3-17</p> <p>    Backlight Adjust . . . . . 3-17</p> <p>    Bank Select . . . . . 3-17</p> <p>    Call Guard Squelch Disable . . . . . 3-17</p> <p>    Emergency Switch . . . . . 3-17</p> <p>    Encryption On-Off . . . . . 3-17</p> <p>    Function Select (High Tier Models) . . . . . 3-18</p> <p>    Home System/Group Select . . . . . 3-18</p> <p>    Horn Alert . . . . . 3-18</p> <p>    LTR System Search Select . . . . . 3-18</p>
---	--

## TABLE OF CONTENTS (CONT'D)

Menu Mode Select . . . . .	3-18	<b>3.12 ELECTRONIC PART, IDENTIFICATION, AND SOFTWARE VERSION NUMBERS . . . . .</b>	3-37
Monitor Mode Select . . . . .	3-18	Introduction . . . . .	3-37
Option Select . . . . .	3-18	Viewing Electronic Part Number . . . . .	3-37
Priority Sampling Select . . . . .	3-18	Viewing Electronic Identification Number . . . . .	3-38
Scan On-Off . . . . .	3-18	Viewing Software Version Number . . . . .	3-38
Scan Type Select . . . . .	3-18		
Scan Continue Select . . . . .	3-18	<b>4 PROGRAMMING</b>	
Scan List Save Mode . . . . .	3-19	<b>4.1 GENERAL . . . . .</b>	4-1
Stealth Mode Select . . . . .	3-19	Programming Setup . . . . .	4-1
Squelch Adjust . . . . .	3-19	Minimum Computer Requirements . . . . .	4-1
System/Group Display Mode . . . . .	3-19	RPI Cables . . . . .	4-2
Talk-Around Select . . . . .	3-19	Remote Programming Interface (RPI) . . . . .	4-2
Tone Type Select . . . . .	3-19	EEPROM Data Storage . . . . .	4-2
<b>3.7 SYSTEM AND GROUP SCAN . . . . .</b>	3-19	Hardware Hookup . . . . .	4-2
General . . . . .	3-19	Powering Up a Data Transceiver . . . . .	4-2
Scan List Programming . . . . .	3-20	<b>4.2 SOFTWARE INSTALLATION INFORMATION . . . . .</b>	4-3
Scan Delay and Continue Timers . . . . .	3-21	General . . . . .	4-3
Transmitting In The Scan Mode . . . . .	3-22	Minimum Free Memory Required . . . . .	4-3
Fixed Transmit In Scan . . . . .	3-22	Software Installation . . . . .	4-3
Scanning LTR Systems . . . . .	3-23	Starting The Program . . . . .	4-4
Scanning Conventional Systems . . . . .	3-23	<b>4.3 MISCELLANEOUS PROGRAM INFORMATION . . . . .</b>	4-4
<b>3.8 LTR FEATURES . . . . .</b>	3-23	Header Information . . . . .	4-4
Systems . . . . .	3-23	Special Keys . . . . .	4-5
Groups . . . . .	3-23	<b>4.4 PROGRAMMING PROCEDURE . . . . .</b>	4-5
Receive Priority ID Codes . . . . .	3-24	<b>4.5 MAIN MENU . . . . .</b>	4-8
LTR Standard Calls . . . . .	3-24	Introduction . . . . .	4-8
LTR Telephone Calls . . . . .	3-25	Set Up New Configuration File . . . . .	4-8
Transmit Inhibit . . . . .	3-26	Open Configuration File . . . . .	4-8
Busy Queuing . . . . .	3-26	Modify Current Configuration File . . . . .	4-9
System Search . . . . .	3-27	Upload Configuration From Radio . . . . .	4-9
Transpond . . . . .	3-27	Download Configuration To Radio . . . . .	4-9
<b>3.9 CONVENTIONAL MODE FEATURES . . . . .</b>	3-27	Print Current Configuration File . . . . .	4-9
Monitor Mode . . . . .	3-27	Modify Printer/Serial Ports . . . . .	4-9
Transmit Disable On Busy . . . . .	3-27	Configuration File Utilities . . . . .	4-10
Receive-Only Groups . . . . .	3-28	<b>4.6 MODIFY RADIO FILE MENU . . . . .</b>	4-10
Talk-Around . . . . .	3-28	Introduction . . . . .	4-10
Call Guard Squelch . . . . .	3-28	Edit Main Radio Parameters . . . . .	4-10
Priority Group Sampling . . . . .	3-29	Define Option Buttons . . . . .	4-12
External Encoders and Decoders . . . . .	3-30	Setup Menu Functions . . . . .	4-12
<b>3.10 SUPERVISORY TONES AND DISPLAY MESSAGES . . . . .</b>	3-31	Create/Edit/Copy/Delete System . . . . .	4-12
General Tones . . . . .	3-31	Create/Edit/Delete Bank . . . . .	4-14
LTR Telephone Call Tones . . . . .	3-32	Setup Prestored Numbers . . . . .	4-15
Display Messages . . . . .	3-32	Setup/Change Unique ID . . . . .	4-16
Menu Mode Messages (High Tier Only) . . . . .	3-33	Change Model/Band/Range/Tier . . . . .	4-16
<b>3.11 TEST MODE . . . . .</b>	3-34	<b>4.7 ADDITIONAL PROGRAMMING INFORMATION . . . . .</b>	4-16
High Tier Option Switch Identification . . . . .	3-34	Repeater Number Programming . . . . .	4-16
Entering Test Mode . . . . .	3-34	Channel Number Programming . . . . .	4-16
Exiting Test Mode . . . . .	3-35	Specifying RIC-Equipped Repeaters . . . . .	4-16
Test Mode Default Conditions . . . . .	3-35		
Test Channel Selection . . . . .	3-35		
Modulation Selection . . . . .	3-35		
Miscellaneous . . . . .	3-35		



## TABLE OF CONTENTS (CONT'D)

<b>4.8</b>	<b>UPDATING RADIO SOFTWARE</b> . . . . .	4-16			
	Introduction . . . . .	4-16			
	Data File . . . . .	4-17			
<b>4.9</b>	<b>I/O LINE PROGRAMMING</b> . . . . .	4-17			
	Introduction . . . . .	4-17			
	Transceiver and Programming Software Required . . . . .	4-18			
	Programming For Options . . . . .	4-18			
	Programming I/O Interface Options . . . . .	4-18			
<b>5</b>	<b>CIRCUIT DESCRIPTION</b>				
<b>5.1</b>	<b>GENERAL TRANSCEIVER DESCRIPTION</b>	5-1			
	Introduction . . . . .	5-1			
	Circuit Protection (Fuses) . . . . .	5-1			
	Synthesizer . . . . .	5-1			
	Audio/Logic Board . . . . .	5-1			
	Receiver . . . . .	5-2			
	Transmitter . . . . .	5-2			
<b>5.2</b>	<b>POWER DISTRIBUTION AND SWITCHING</b>	5-2			
	Power Switching Control . . . . .	5-2			
	Supply Switching . . . . .	5-2			
<b>5.3</b>	<b>AUDIO/LOGIC BOARD DIGITAL CIRCUIT</b>	5-4			
	Microcontroller (U101) . . . . .	5-4			
	Memory and Latch Programming . . . . .	5-6			
<b>5.4</b>	<b>RECEIVE AUDIO/DATA PROCESSING</b> . . . . .	5-7			
	Amplifier (U301B) . . . . .	5-7			
	Receive Audio Processing . . . . .	5-8			
	Receive Data Processing . . . . .	5-9			
	Squelch Circuit (U304A, U304B) . . . . .	5-9			
<b>5.5</b>	<b>TRANSMIT AUDIO/DATA PROCESSING</b> . . . . .	5-10			
	Microphone Amplifier (U303B), High-Pass Filter (U303C) . . . . .	5-10			
	Summing Amplifier (U303D), Pre-Emphasis/ Limiter (U303A) . . . . .	5-10			
	Splatter Filter (U302B, U302C) . . . . .	5-10			
	Transmit Data Circuit (U302D, U302A) . . . . .	5-11			
<b>5.6</b>	<b>DISPLAY BOARDS</b> . . . . .	5-11			
<b>5.7</b>	<b>SYNTHESIZER CIRCUIT DESCRIPTION   (UHF MODELS)</b> . . . . .	5-12			
	Introduction . . . . .	5-12			
	Voltage-Controlled Oscillator . . . . .	5-12			
	Active Filter (Q800), Buffer Amplifier (Q801) . . . . .	5-14			
	VCO and TCXO Modulation . . . . .	5-15			
	Synthesizer Integrated Circuit (U804) . . . . .	5-15			
	Lock Detect . . . . .	5-17			
	Charge Pump . . . . .	5-17			
	Shift Register (U800, U801) and Digital Potentiometer (U802) Programming . . . . .	5-17			
<b>5.8</b>	<b>RECEIVER CIRCUIT DESCRIPTION (UHF   MODELS)</b> . . . . .	5-17			
	Front End Filter . . . . .	5-17			
	RF Amplifier (Q201) . . . . .	5-18			
	First Mixer (Q202), Injection Amplifier (Q204) . . . . .	5-18			
	Second Mixer/Detector (U201) . . . . .	5-18			
<b>5.9</b>	<b>TRANSMITTER CIRCUIT DESCRIPTION   (UHF MODELS)</b> . . . . .	5-19			
	First and Second Amplifiers . . . . .	5-19			
	Third Amp and Predriver . . . . .	5-20			
	Driver (Q600), Final (Q601) . . . . .	5-21			
	Antenna Switch . . . . .	5-21			
	Directional Coupler, Low-Pass Filter . . . . .	5-21			
	Power Control (U500A/B, Q500-Q503) . . . . .	5-22			
<b>5.10</b>	<b>SYNTHESIZER CIRCUIT DESCRIPTION   (800/900 MHz MODELS)</b> . . . . .	5-24			
	Introduction . . . . .	5-24			
	Voltage-Controlled Oscillator . . . . .	5-24			
	VCO and TCXO Modulation . . . . .	5-25			
	Active Filter (Q800) . . . . .	5-26			
	Buffer Amplifier (Q801), Tx/Tx Switch (CR801/CR802) . . . . .	5-26			
	Synthesizer Integrated Circuit (U804) . . . . .	5-27			
	Lock Detect . . . . .	5-28			
	Charge Pump . . . . .	5-28			
	Shift Register (U800, U801) and Digital Potentiometer (U802) Programming . . . . .	5-28			
<b>5.11</b>	<b>RECEIVER CIRCUIT DESCRIPTION   (800/900 MHz MODELS)</b> . . . . .	5-28			
	Front End Filter . . . . .	5-28			
	RF Amplifier (Q201) . . . . .	5-28			
	First Mixer (Q202), Crystal Filter (Z204) . . . . .	5-29			
	Second Mixer/Detector (U201) . . . . .	5-29			
<b>5.12</b>	<b>TRANSMITTER CIRCUIT DESCRIPTION   (800/900 MHz MODELS)</b> . . . . .	5-30			
	Predriver (Q506), Driver (Q507) . . . . .	5-30			
	Power Amplifier Module (U600), Final (Q651) . . . . .	5-31			
	Antenna Switch . . . . .	5-31			
	Directional Coupler, Low-Pass Filter . . . . .	5-31			
	Power Control (U500A/B, Q500-Q503) . . . . .	5-32			
<b>6</b>	<b>SERVICING</b>				
<b>6.1</b>	<b>GENERAL</b> . . . . .	6-1			
	Periodic Checks . . . . .	6-1			
	Schematic Diagrams and Component Layouts . . . . .	6-1			
	Replacement Parts . . . . .	6-1			
	Configuring Transceiver for Testing . . . . .	6-1			
<b>6.2</b>	<b>SURFACE MOUNTED DEVICES (SMDs)</b> . . . . .	6-1			
	Servicing Techniques . . . . .	6-1			
	Identifying SMD Resistors . . . . .	6-1			
	SMD Capacitor Identification . . . . .	6-2			
	SMD Inductor Identification . . . . .	6-3			
	Transistor/Diode Identification . . . . .	6-3			
<b>6.3</b>	<b>SYNTHESIZER TROUBLESHOOTING</b> . . . . .	6-3			
	Introduction . . . . .	6-3			
	Reference Oscillator (U806) . . . . .	6-4			

## TABLE OF CONTENTS (CONT'D)

VCO Module .....	6-4		
Synthesizer IC (U804) .....	6-4		
Determining Synthesizer Counter Divide Numbers .....	6-5		
<b>6.4 RECEIVER SERVICING</b> .....	6-5		
<b>6.5 TRANSMITTER SERVICING</b> .....	6-5		
<b>6.6 AUDIO/LOGIC BOARD SERVICING</b> .....	6-5		
Digital Circuits .....	6-5		
Analog Circuits .....	6-5		
<b>7 ALIGNMENT PROCEDURE AND PERFORMANCE TESTS</b>			
<b>7.1 GENERAL</b> .....	7-1		
Introduction .....	7-1		
Test Mode .....	7-1		
Test Setup .....	7-2		
<b>7.2 USING TUNE SOFTWARE</b> .....	7-2		
General .....	7-2		
Installation .....	7-2		
Program Operation .....	7-2		
Tune Radio Screen .....	7-3		
<b>7.3 ADJUSTMENT PROCEDURE</b> .....	7-4		
Preliminary .....	7-4		
Frequency and Bias Adjustment .....	7-4		
Modulation Peak Frequency (UHF Models Only) .....	7-4		
Power Output .....	7-4		
Modulation Balance .....	7-5		
Transmit Audio Limiting .....	7-5		
Transmit Data Level .....	7-5		
Receiver IF Adjustment .....	7-5		
Squelch Level Adjust .....	7-6		
<b>7.4 RECEIVER PERFORMANCE TESTS</b> .....	7-7		
<b>7.5 TRANSMITTER PERFORMANCE TESTS</b> .....	7-7		
Checking Power Output .....	7-7		
Checking Frequency .....	7-7		
Checking Deviation .....	7-7		
<b>8 PARTS LIST</b>			
Front Panel Assembly And Mechanical Parts ..	8-1		
UHF RF And PA Boards .....	8-3		
800/900 MHz RF And PA Boards .....	8-18		
Audio/Logic Board (All Models) .....	8-26		
9800-Series Radio Mounting Kit .....	8-31		
9800-Series Remote Mounting Kit .....	8-31		
DC Power Cable And Hardware Kit .....	8-31		
Accessory Wire Kit .....	8-31		
Amplified Dynamic Microphone .....	8-31		
15 Watt, 4.7-Ohm Speaker (Black) .....	8-32		
		<b>Exploded Views</b>	
		High Tier Front Panel .....	8-33
		Low Tier Front Panel .....	8-34
		Front And Top Mechanical Parts .....	8-32
		Bottom Mechanical Parts .....	8-32
		Remote Control Unit Mechanical Parts ....	8-33
		Remote Transceiver Mechanical Parts .....	8-33
	<b>9</b>	<b>SCHEMATIC DIAGRAMS AND COMPONENT LAYOUTS</b>	
		Transistor and Diode Basing Diagrams .....	9-1
		Amplified Dynamic Microphone .....	9-2
		Transceiver Top Photo .....	9-3
		Transceiver Bottom Photo .....	9-3
		<b>High Tier Interconnect Schematic</b> .....	9-4
		<b>High Tier Interface Board Layout</b> .....	9-4
		<b>High Tier Display Board</b>	
		Top View .....	9-5
		Bottom View .....	9-5
		<b>RPI (P.N. 023-9800-000)</b>	
		RPI (P.N. 023-9800-000) Board Layout .....	9-6
		Programming Cable .....	9-6
		RPI (P.N. 023-9800-000) Schematic .....	9-6
		<b>Component Locator Guides</b>	
		RF Board (UHF) .....	9-7
		RF Board (800/900 MHz) .....	9-10
		Audio/Logic Board .....	9-12
		<b>430-470 MHz RF</b>	
		RF Board Schematic (Revised) .....	9-15
		PA Board Schematic (25W) .....	9-15
		RF Board Layout .....	9-16
		VCO Board Layout .....	9-17
		PA Board Layout (25W) .....	9-17
		PA Board Schematic (40W) .....	9-18
		PA Board Layout (40W) .....	9-19
		RF Board Schematic (Unrevised) .....	9-20
		RF Board Layout (Unrevised) .....	9-21
		<b>470-512 MHz RF</b>	
		RF Board Schematic .....	9-22
		PA Board Schematic (25W) .....	9-22
		RF Board Layout .....	9-23
		VCO Board Layout .....	9-24
		PA Board Layout (25W) .....	9-24
		PA Board Schematic (40W) .....	9-25
		PA Board Layout (40W) .....	9-26
		<b>800/900 MHz RF</b>	
		RF Board Schematic .....	9-27
		PA Board Schematic (15W) .....	9-27



## TABLE OF CONTENTS (CONT'D)

### LIST OF FIGURES

1-1	Data Transceiver . . . . .	1-2
2-1	Front Mount Installation Components . . . . .	2-1
2-2	Remote Mount Installation Components . . . . .	2-3
2-3	Accessory Cable Installation . . . . .	2-4
2-4	Accessory Cable Connector . . . . .	2-5
2-5	R170 Location Diagram . . . . .	2-5
2-6	Data Cable Installation (-001 Cable Shown) . . . . .	2-7
3-1	Frt Panel Controls and Indicators (Low-Tier) . . . . .	3-1
3-2	Front Panel Controls and Indicators (High-Tier) . . . . .	3-1
3-3	Low Tier Display and Indicators . . . . .	3-4
3-4	High Tier Display . . . . .	3-5
4-1	Programming Setup . . . . .	4-1
4-2	Main Menu . . . . .	4-7
4-3	Modify Radio File Screen . . . . .	4-11
4-4	Define Option Buttons Screen . . . . .	4-13
4-5	Setup Menu Functions Screen . . . . .	4-13
4-6	Channel Display Screen (Low Tier Only) . . . . .	4-15
4-7	I/O Interface Options Screen . . . . .	4-17
5-1	Power Distribution and Switching . . . . .	5-3
5-2	Power On-Off Control Circuit . . . . .	5-3
5-3	Audio/Data Processing Circuitry Block Diagram . . . . .	5-8
5-4	RF Block Diagram (UHF Models) . . . . .	5-13
5-5	Synthesizer Chip U804 Block Diagram . . . . .	5-16
5-6	Limiter/Detector U201 Block Diagram . . . . .	5-19
5-7	RF Block Diagram (800/900 MHz Models) . . . . .	5-23
6-1	Simplified Synthesizer Block Diagram . . . . .	6-3
7-1	Alignment Setup . . . . .	7-1
7-2	Tune Program Opening Screen . . . . .	7-3
7-3	Radio Tuner Menu . . . . .	7-3
7-4	Alignment Points Diagram . . . . .	7-5
B-1	Ext Device Access To Subscriber Logic Cntrlr . . . . .	B-6
B-2	Power-Down Request Accepted . . . . .	B-9
B-3	Broadcast Power-Down . . . . .	B-9
B-4	Power-Down Request Denied . . . . .	B-9
B-5	Addressed Power-Off . . . . .	B-9

## SECTION 1 GENERAL INFORMATION

### 1.1 SCOPE OF MANUAL

This service manual contains installation, operation, programming, alignment, and service information for E.F. Johnson LTR<sup>®</sup> 984x UHF, 988x 800 MHz, and 989x 900 MHz transceivers. Information is included for low and high tier versions of these transceivers, and also for both UHF frequency bands (430-470 and 470-512 MHz).

This manual replaces Part No. 001-9800-200 and the -201/-202 revisions, and Part No.s 001-9880-200 and 001-9840-203. However, the -9800- manuals do not cover discontinued mid tier models or early unrevised boards, so you may want to retain your copies of the -9880- or -9840- manuals for that information.

In addition, this manual does not cover operation, programming, and alignment of LTR-Net<sup>™</sup>, SMARTNET<sup>™</sup>, or SmartZone<sup>®</sup> 98xx models. It also does not cover operation and programming of Multi-Net<sup>®</sup> models. This information is located in other manuals.

### 1.2 TRANSCEIVER DESCRIPTION

#### 1.2.1 GENERAL

The 98xx-series transceivers combine the latest two-way radio features and technology into a rugged and dependable package for the business, industrial, and public safety markets. These transceivers are digitally synthesized, microcomputer-controlled, and field programmable. All LTR models can be programmed for both LTR and conventional operation.

#### 1.2.2 AVAILABLE FREQUENCY BANDS

##### UHF Models

- 430-470 MHz or 470-512 MHz models available.
- All currently available models are dual bandwidth (12.5/25 kHz). Therefore, they can be programmed to operate on both types of channels.
- High power (40W) or medium power (25W) models available.

##### 800 MHz Models

- Full band (806-824 MHz) operation.
- All currently available models are dual bandwidth (12.5/25 kHz).
- High power (30W) and medium power (15W) models available.

##### 900 MHz Models

- Full band (896-902 MHz) operation.
- Only narrow band (12.5 kHz) models are available because the 900 MHz band has always had a 12.5 kHz channel spacing.
- High power (30W) and medium power (15W) models available.

#### 1.2.3 LOW AND HIGH TIER MODELS

Each UHF, 800 MHz, or 900 MHz model is available in a low or high tier version. The tier determines operating features, and the highlights of each tier are as follows. Refer to Section 3.1 for more information on the operating features.

*NOTE: Mid tier models are no longer available. For information on mid tier features, see Section 1.1.*

##### Low Tier Models

- Up to 16 system/group combinations (channels) programmable. These combinations can be programmed from up to 16 systems with up to 16 groups each.
- A 1.5-digit LED type display indicates the selected system/group combination (channel) from 1-16.
- Each system/group combination can be scanned and the scan list is programmable. Group-only scanning is not available.
- The front panel and logic board assemblies are unique to this model.

- Same specifications as high tier models.

### High Tier Models

- Up to 100 systems are programmable, and each system can be programmed with up to 16 groups. However, because of memory limitations, it is not possible to program 100 16-group systems. The total number of systems that can be programmed decreases as the number of groups in each system increases. In addition, the system type (LTR or conventional) and the size of the channel table also affect the number that can be programmed.

For example, up to 100 1-group systems can be programmed, and the maximum number decreases to approximately 40 16-group systems. As data is entered using the personality programming software, a running indication of the amount of memory remaining is displayed (see Section 4.3.1).

- Up to 16 banks of systems are programmable.
- All five option switches are programmable.
- The front panel and logic board assemblies are unique to this model.



**Figure 1-1 Data Transceiver**

### 1.2.4 DATA MODELS

A data version of this transceiver is available in each frequency range (see Section 1.3). Both medium and high power models are available. This transceiver has a blank front panel (see Figure 1-1) and uses the same RF and PA boards as standard models. However, the audio/logic board is an enhanced version of the low-tier model minus display-related components. The data transfer rate is 4800 bits per second over a 25 kHz channel. As with standard models, operation on

conventional or LTR systems and group IDs can be programmed, and scanning can be used to prevent missed calls.

The data equipment is connected to the transceiver via a pigtail cable extending from the back panel (see Section 2.7). The front panel jack is used for programming. The data interface and serial protocol are described in Appendix A and Appendix B of this manual. In general, the data transceiver has the operating, data interface, and data protocol features of standard high tier models.

### CAUTION

*DO NOT apply power a transceiver that has one of the data cables installed without first properly terminating the wires of that cable. These wires carry differing potentials and transceiver damage may result if they inadvertently contact each other with power applied.*

### 1.2.5 FRONT AND REMOTE MOUNTING

High tier models are available in both front- and remote-mount versions, and low tier models are available in a front mount version only. Remote mount versions are intended to be mounted in a remote location up to approximately 17 feet away from the control unit such as the vehicle's trunk. Front mount versions are intended to be mounted within reach of the operator.

The control unit connects to the remote pigtail cable coming from the back panel of the transceiver. This cable is standard with remote mount models and optional with front mount models. The remote control unit uses the high tier front panel assembly. A Remote Conversion Kit is available for converting a front mount high tier model to remote mounting (see Table 1-3). The transceiver does not have dual-control capability. Therefore, either the front panel or a remote control unit can be used for control, but not both.

### 1.2.6 NPSPAC MODELS (800 MHZ ONLY)

All 800 MHz 988x transceivers capable of operating on 25 kHz channels meet the stricter specifications established by NPSPAC (National Public Safety Panel Advisory Committee) for public safety frequencies from 821-824 and 866-869 MHz. Since deviation is less on NPSPAC channels, an additional screen is

may be displayed by the tuning software with 800 MHz models for setting NPSPAC deviation. Then when a public safety channel is selected, the deviation automatically changes to the level set in this screen.

### 1.2.7 PROGRAMMING

Transceiver programming is performed using a PC-compatible computer, the EFJohnson Remote Programming Interface (RPI), and EFJohnson programming software (see Table 1-3).

Three types of programming can be performed with 9800 series transceivers and they are (1) Personality, (2) Flash, and (3) Tune. Personality and Flash programming are described in the following information and Tune programming is described in Section 1.2.8.

Standard Personality programming sets the parameters that can be different for each transceiver. This includes channel frequencies, system and group information, and operating features. This programming is performed using the Personality programming software listed in Table 1-3.

Version 204 or later personality programming software is required to program high tier models, and Version 205 or later is required to program UHF 470-512 MHz models. Refer to Sections 4.1 - 4.7 for more information on personality programming.

Flash programming updates the operating software of the transceiver. A reprogrammable Flash EPROM is used to store the operating software (and most of the personality information). Flash programming allows the operating software to be easily updated in the field without the need for replacing expensive microprocessors or memory devices. This programming is performed using the standard Personality programming setup and special Flash programming software listed in Table 1-3. Refer to Section 4.8 for more information on Flash programming.

### 1.2.8 TRANSCEIVER ALIGNMENT

Alignment is performed using the standard Personality programming setup and special Radio Tune software. There are only two or three adjustments that are made by physically adjusting a component on the PC board. All other adjustments are set

digitally. The desired setting is selected using the computer, and it is then automatically stored in the transceiver memory. If the manual adjustments do not need to be readjusted, transceiver alignment can usually be performed without removing the covers. Refer to Section 7 for more alignment information.

### 1.3 PART NUMBER BREAKDOWN

The breakdown of the part number used to identify this transceiver is shown in Table 1-1. This number is also stored electronically and can be read as described in Section 3.12.

**Table 1-1 Part Number Breakdown**

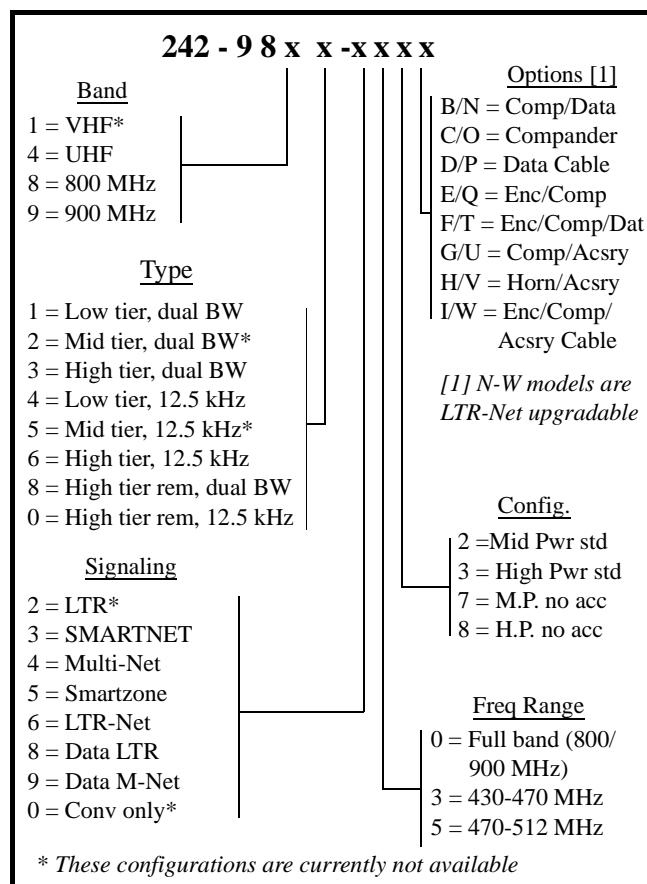

### 1.4 TRANSCEIVER IDENTIFICATION

The transceiver identification number is printed on a label that is attached to the chassis. The information is contained in this number is shown in Table 1-2. This number is also stored electronically and can be read using the programming software as described in Section 3.12.

**Table 1-2 Identification Number Breakdown**

Model From P.N.	Revision Letter	Manufacture Date	Plant	Warranty Number
98xx	x A	10 0	A	12345

<p><b>Type</b></p> <p>1 = Low pwr LTR                  2 = High pwr LTR                  3 = High pwr Data MN                  4 = Low pwr LTR-Net                  5 = High pwr LTR-Net                  6 = Low pwr Multi-Net                  7 = High pwr Multi-Net                  8 = Low pwr Data LTR                  9 = High pwr Data LTR                  0 = Low pwr Data MNet                  A = SMARTNET/SmartZone</p>	<p>A = Waseca</p> <p>Last Digit of Year</p> <p>Week No. of Year</p> <p><i>NOTE: Low power = 25W UHF, 15W 800/900 MHz;                  High power = 40W UHF, 30W 800/900 MHz)</i></p>
---	---

**1.5 ACCESSORIES**

The accessories available for this transceiver are listed in Table 1-3. The following is a brief description of most of these accessories.

**Mounting Accessories** - The -030 mounting kit contains mounting knobs and four self-drilling screws. The -610 kit contains mounting knobs, a remote mounting bracket, and four self drilling screws. The 10- and 22-ft. cable kits include a fused power cable and microphone hanger with a ground wire.

**Key Cap Kit** - A key cap kit which includes five caps labeled for common functions is standard with each transceiver. Optional kits are also available. Refer to Section 2.8 for more key cap information.

**Microphones and Speaker** - The microphones have an impedance of 620 ohms, and all DTMF models have backlighted keypad but no memory for storing numbers. The WR805 microphone is environmentally sealed against such things as rain, sand, and dust. The desk microphone has a monitor button that can be locked down if desired.

The remote 15-watt speaker can be used instead of the internal speaker. It is non-amplified and weather resistant, and has a 6-ft. cable. It plugs into the external speaker jack in the back panel (with both

**Table 1-3 98xx Accessories**

Accessory	Part No.
<b>Mounting Accessories</b>	
Front mounting kit	023-9800-030
Remote mounting kit	023-9800-040
10 ft. DC power cable and hardware kit	023-9800-410
22-ft. DC power cable and hardware	023-9800-422
Standard mounting bracket	017-2229-005
Low-profile mounting bracket	017-2229-010
Standard Key Cap Kits (5 key caps)	587-9840-001
Optional Key Cap Kits (20+ key caps) (see Section 2.8 for more keycap info)	587-9840-004
<b>Microphones</b>	
Standard amplified dynamic	250-0740-300
Standard DTMF w/lighted keypad	250-0751-021
WR 805 DTMF (weather resistant)	589-0016-029
Desk-type	250-0742-010
Remote Speaker, 5", 15W, 4.7 ohm	250-0151-010
Remote conversion kit	250-9800-001
Remote control extension cable, 11 ft.	597-9800-009
Remote control pigtail cable (for xcvr)	597-9800-011
<b>Accessory cable components</b>	
Accessory pigtail cable	597-9800-003
Accessory wire kit	023-9750-011
Data/accessory cable kit (both cables included, w/o data connector)	597-9800-001
Data pigtail cable (data cable only w/o data connector)	597-9800-005
Compander kit	250-9800-310
Encryption kit, Transcrypt® SC20-4xx	SC20-4xx
<b>Desktop Power Supply</b>	
15 A, 117 VAC	239-0226-113
15 A, 230 VAC	239-0226-213
Wedge mounting pedestal kit (includes 10 ft. power cable)	023-8610-914
<b>Programming Accessories</b>	
Remote Programming Interface (RPI) Cable, RPI to transceiver	023-9800-000
Cable, RPI to computer, 6 ft. (DB9F to DB9M)	597-2002-200
Cable, RPI to computer, 6 ft. (DB9F to DB9M)	597-5900-002
Programming software, supplied on 3-1/2", 1.44M diskette only	
Personality Programming Software	023-9998-414
Flash Programming Software	023-9998-432
Radio Tuning Software	023-9998-416



front and remote mount applications), and the internal speaker is automatically disabled when it is used.

**Remote Mounting Components** - The remote conversion kit converts the front panel of a front mount high tier transceiver to a remote control unit. It includes a blank front cover for the transceiver, a housing and 5-ft. control cable for the front panel, and a 1-ft. pigtail cable for connecting the control unit to the transceiver. If the control unit is to be mounted more than approximately 6 feet from the transceiver, the 11-ft. extension cable is required (see Figure 2-2).

**Accessory Cable** - The -003 pigtail cable installs in the transceiver, and the wire kit is used to connect accessories to this cable. Included in the wire kit are two 22-ft. and three 2-ft. wire assemblies that can be used as desired. The accessory cable is required if such things as ignition switch control of power or the horn alert are used. Refer to Section 2.4 for installation information.

**Data/Accessory Cable** - The -001 cable assembly includes a data pigtail cable that plugs into J301 on the audio/logic board and also the accessory pigtail described above. The -005 cable assembly is a data cable only without the accessory cable. Neither cable includes the connector that interfaces with the data equipment, so it must be user supplied and installed. Installation of this cable is described in Section 2.7.

**Compondor and Encryption Kits** - The compandor kit includes a board assembly that installs in the option wire-outs on the audio/logic board to provide companding. Likewise, the encryption kit includes a board assembly that connects to the other option wire-outs on the audio/logic board. Contact your sales representative for more information on available encryption options.

**Desktop Accessories** - The -113 and -213 power supplies include a pedestal for mounting the transceiver and also include an internal speaker. The wedge mounting pedestal includes a 10-ft power cable. Also required when this pedestal is used is one of the power supplies and the -010 low profile mounting bracket.

**Programming Accessories** - This RPI has design enhancements required for Flash programming the 9800-series transceivers. It also has jacks for injecting

a microphone audio signal and monitoring receive audio when aligning the transceiver. Earlier RPIs (such as 023-9750-000 and 023-5810-000) can be used to program personality information if desired.

## 1.6 PRODUCT WARRANTY

The warranty statement for this transceiver is available from your product supplier or from the Warranty Department, E.F. Johnson Company, 299 Johnson Avenue, P.O. Box 1249, Waseca, MN 56093-0514. This information may also be requested from the Warranty Department by phone as described in Section 1.7. The Warranty Department may also be contacted for Warranty Service Reports, claim forms, or any other questions concerning warranties or warranty service.

## 1.7 FACTORY CUSTOMER SERVICE

The Customer Service Department of the E.F. Johnson Company provides customer assistance on technical problems and the availability of local and factory repair facilities. Regular Customer Service hours are 7:30 a.m. - 5:30 p.m. Central Time, Monday - Friday. The Customer Service Department can be reached at the following telephone numbers:

**Toll-Free: 1-800-328-3911**

(From within continental United States only)

**International: (507) 835-6911**

**FAX: (507) 835-6969**

**E-Mail: [customerservice@efjohnson.com](mailto:customerservice@efjohnson.com)**

*NOTE: Emergency 24-hour technical support is also available at the 800 and preceding numbers during off hours, holidays, and weekends.*

When your call is answered, you will hear a brief message informing you of numbers that can be entered to reach various departments. This number may be entered during or after the message using a tone-type telephone. When you enter some numbers, another number is requested to further categorize the type of information you need.

You may also contact the Customer Service Department by mail. Please include all information

that may be helpful in solving your problem. The mailing address is as follows:

E.F. Johnson Company  
Customer Service Department  
299 Johnson Avenue  
P.O. Box 1249  
Waseca, MN 56093-0514

## 1.8 FACTORY RETURNS

Repair service is normally available through local authorized EFJohnson Land Mobile Radio Service Centers. If local service is not available, the equipment can be returned to the factory for repair. However, it is recommended that you contact the Customer Service Department before returning equipment. A service representative may be able to suggest a solution to the problem making return of the equipment unnecessary.

Be sure to fill out a Factory Repair Request Form #271 for each unit to be repaired, whether it is in or out of warranty. These forms are available free of charge by calling Customer Service (see Section 1.7) or by requesting them when you send a unit in for repair. Clearly describe the difficulty experienced in the space provided and also note any prior physical damage to the equipment. Include this form in the shipping container with each unit. Your telephone number and contact name are important as there are times when the technicians may have specific questions that need to be answered in order to completely identify and repair a problem.

When returning equipment for repair, it is also a good idea to use a PO number or some other reference number on your paperwork in case you need to call the repair lab about your unit. These numbers are referenced on the repair order making it easier and faster to locate your unit in the lab.

Return Authorization (RA) numbers are not necessary unless you have been given one by the Field

Service Department. RA numbers are required for exchange units or if the Field Service Department wants to be aware of a specific problem. If you have been given an RA number, reference this number on the Factory Repair Request Form sent with the unit. The repair lab will then contact the Field Service Department when the unit arrives.

For more information on factory service, contact the Depot Service Department at the following E-mail address: [depotrepair@efjohnson.com](mailto:depotrepair@efjohnson.com)

## 1.9 REPLACEMENT PARTS

EFJohnson replacement parts can be ordered directly from the Service Parts Department. To order parts by phone, dial the toll-free number as described in Section 1.7. When ordering, please supply the part number and quantity of each part ordered. EFJohnson dealers also need to give their account number. If there is uncertainty about the part number, include the designator (C512, for example) and the model number of the equipment the part is from.

You may also send your order by mail or FAX. The mailing address is as follows and the FAX number is shown in Section 1.7.

E.F. Johnson Company  
Service Parts Department  
299 Johnson Avenue  
P.O. Box 1249  
Waseca, MN 56093-0514

## 1.10 INTERNET HOME PAGE

The E.F. Johnson Company has a site on the World Wide Web that can be accessed for information on the company about such things as products, systems, and regulations. The address is as follows: <http://www.efjohnson.com>

## UHF 984x SPECIFICATIONS

The following are general specifications intended for use in testing and servicing this transceiver. For current advertised specifications, refer to the specification sheet available from your sales representative. Specifications are subject to change without notice.

### GENERAL

Frequency Range	430-470 MHz and 470-512 MHz
Operating Modes	LTR (trunked) and Conventional (non-trunked)
Systems and Groups Selectable	Low Tier: Up to 16 system/group combinations High Tier: Variable from 100 1-group systems up to 40 16-group systems
Mounting Location	Dash (low tier), Dash or Remote (high tier)
Transmit/Receive Separation	Any frequency within the range
Channel Spacing	12.5 kHz (2.5 kHz maximum deviation) 25 kHz (5 kHz maximum deviation) (12.5 kHz or dual bandwidth models available)
Frequency Stability	2.0 PPM from -22° to +140° F (-30° to +60° C)
Dimensions	2.1" x 6.0" x 7.5" (HxWxD)
Weight	3.5 lbs (1.59 kg)
Power Requirement	13.6 volts DC nominal, negative ground
Current Drain	300 mA maximum (receive standby) 1.5 A maximum (receive, rated audio output) 10.0 A maximum (transmit, 25 W output) 15.0 A maximum (transmit, 40 W output)
FCC Compliance	Parts 15 and 90

### RECEIVER

Sensitivity (12 dB SINAD)	0.35 $\mu$ V
Selectivity	-70 dB at 25 kHz, -60 dB at 12.5 kHz
Spurious and Image Rejection	-70 dB
Intermodulation	-70 dB
Hum and Noise	-45 dB at 25 kHz, -40 dB at 12.5 kHz
Maximum Frequency Spread	Any spread within the range
Audio Power Output	5 watts (external 4.7-ohm speaker), 3 watts (internal 8-ohm speaker)
Audio Distortion	Less than 5% at 1 kHz with 60% deviation
Audio Response	+1, -3 dB per octave de-emphasis per standard TIA
RF Input Impedance	50 ohms

### TRANSMITTER

RF Power Output	25W Version - 25 watts (adjustable to 2-25 watts) 40W Version - 40 watts (adjustable to 10-40 watts)
Spurious and Harmonic Emissions	-70 dB
FM Hum and Noise	-40 dB (25 kHz), -35 dB (12.5 kHz)
Audio Modulation	25 kHz - 16K0F3E (voice) 16K0F1D (data)
Audio Distortion	Less than 3% at 1 kHz with 40% modulation
Audio Frequency Response	6 dB per octave pre-emphasis per standard TIA
Maximum Frequency Spread	Any spread within the band
RF Output Impedance	50 ohms
Duty Cycle	20% standard TIA

## 800 MHz 988x SPECIFICATIONS

The following are general specifications intended for use in testing and servicing this transceiver. For current advertised specifications, refer to the specification sheet available from your sales representative. Specifications are subject to change without notice.

### GENERAL

Frequency Range	Transmit - 806-824 MHz Std., 851-869 MHz conv. talk-around Receive - 851-869 MHz
Operating Modes	LTR (trunked) and Conventional (non-trunked)
Systems and Groups Selectable	Low Tier: Up to 16 system/group combinations High Tier: Variable from 100 1-group to approx. 40 16-group systems
Mounting Location	Dash (low tier), Dash or Remote (high tier)
Transmit/Receive Separation	45 MHz standard, 0 MHz conventional talk-around
Channel Spacing	12.5 kHz (2.5 kHz maximum deviation) 25 kHz (5 kHz max deviation std, 4 kHz max NPSPEC)
Frequency Stability	1.5 PPM from -22° to +140° F (-30° to +60° C)
Dimensions	2.1" x 6.0" x 7.5" (HxWxD)
Weight	3.5 lbs (1.59 kg)
Power Requirement	13.6 volts DC nominal, negative ground
Current Drain	300 mA maximum (receive standby) 1.5 A maximum (receive, rated audio output) 7.0 A maximum (transmit, 15 W output) 11.0 A maximum (transmit, 30W output)
FCC Compliance	Parts 15 and 90

### RECEIVER

Sensitivity (12 dB SINAD)	0.35 $\mu$ V
Selectivity	-70 dB at 25 kHz, -60 dB at 12.5 kHz
Spurious and Image Rejection	-70 dB
Intermodulation	-70 dB
Hum and Noise	-40 dB at 25 kHz, -35 dB at 12.5 kHz
Maximum Frequency Spread	Any spread within the range
Audio Power Output	5 watts (external 4.7-ohm speaker), 3 watts (internal 8-ohm speaker)
Audio Distortion	Less than 5% at 1 kHz with 60% deviation
Audio Response	+1, -3 dB per octave de-emphasis per standard TIA
RF Input Impedance	50 ohms

### TRANSMITTER

RF Power Output	Medium power version - 15 watts (adjustable to 2-15 watts) High power version - 30 watts (adjustable to 10-30 watts)
Spurious and Harmonic Emissions	-70 dB
FM Hum and Noise	-45 dB (25 kHz), -38 dB (12.5 kHz)
Audio Modulation	25 kHz - 16K0F3E (voice) 19K6F1D (data) NPSPEC - 14K0F3E (voice) 17K6F1D (data)
Audio Distortion	Less than 5% at 1 kHz with 40% modulation
Audio Frequency Response	6 dB per octave pre-emphasis per standard TIA
RF Output Impedance	50 ohms
Duty Cycle	20% standard TIA

## 900 MHz 989x SPECIFICATIONS

The following are general specifications intended for use in testing and servicing this transceiver. For current advertised specifications, refer to the specification sheet available from your sales representative. Specifications are subject to change without notice.

### GENERAL

Frequency Range	Transmit - 896-902 MHz Std., 935-941 MHz conv. talk-around Receive - 935-941 MHz
Operating Modes	LTR (trunked) and Conventional (non-trunked)
Systems and Groups Selectable	Low Tier: Up to 16 system/group combinations Mid Tier: Up to 16 systems with up to 16 groups each High Tier: Variable from 100 1-group to approx. 40 16-group systems
Mounting Location	Dash (low tier), Dash or Remote (high tier)
Transmit/Receive Separation	39 MHz standard, 0 MHz talk-around
Channel Spacing	12.5 kHz
Frequency Stability	1.5 PPM from -22° to +140° F (-30° to +60° C)
Dimensions	2.1" x 6.0" x 7.5" (HxWxD)
Weight	3.5 lbs (1.59 kg)
Power Requirement	13.6 volts DC nominal, negative ground
Current Drain	300 mA maximum (receive standby) 1.5 A maximum (receive, rated audio output) 7.0 A maximum (transmit, 15 W output) 11.0 A maximum (transmit, 30W output)
FCC Compliance	Parts 15 and 90

### RECEIVER

Sensitivity (12 dB SINAD)	0.35 $\mu$ V
Selectivity	-65 dB
Spurious and Image Rejection	-70 dB
Intermodulation	-70 dB
Hum and Noise	-38 dB
Maximum Frequency Spread	Any spread within the range
Audio Power Output	5 watts (external 4.7-ohm speaker), 3 watts (internal 8-ohm speaker)
Audio Distortion	Less than 5% at 1 kHz with 60% deviation
Audio Response	+1, -3 dB per octave de-emphasis per standard TIA
RF Input Impedance	50 ohms

### TRANSMITTER

RF Power Output	Medium power version - 15 watts (adjustable to 2-15 watts) High power version - 30 watts (adjustable to 10-30 watts)
Spurious and Harmonic Emissions	-70 dB
FM Hum and Noise	-40 dB
Audio Modulation	12.5 kHz - 11K0F3E (voice) 11K6F1D (data)
Audio Distortion	Less than 5% at 1 kHz with 40% modulation
Audio Frequency Response	6 dB per octave pre-emphasis per standard TIA
Maximum Frequency Spread	Any spread within the band
RF Output Impedance	50 ohms
Duty Cycle	20% standard TIA



SECTION 2 INSTALLATION

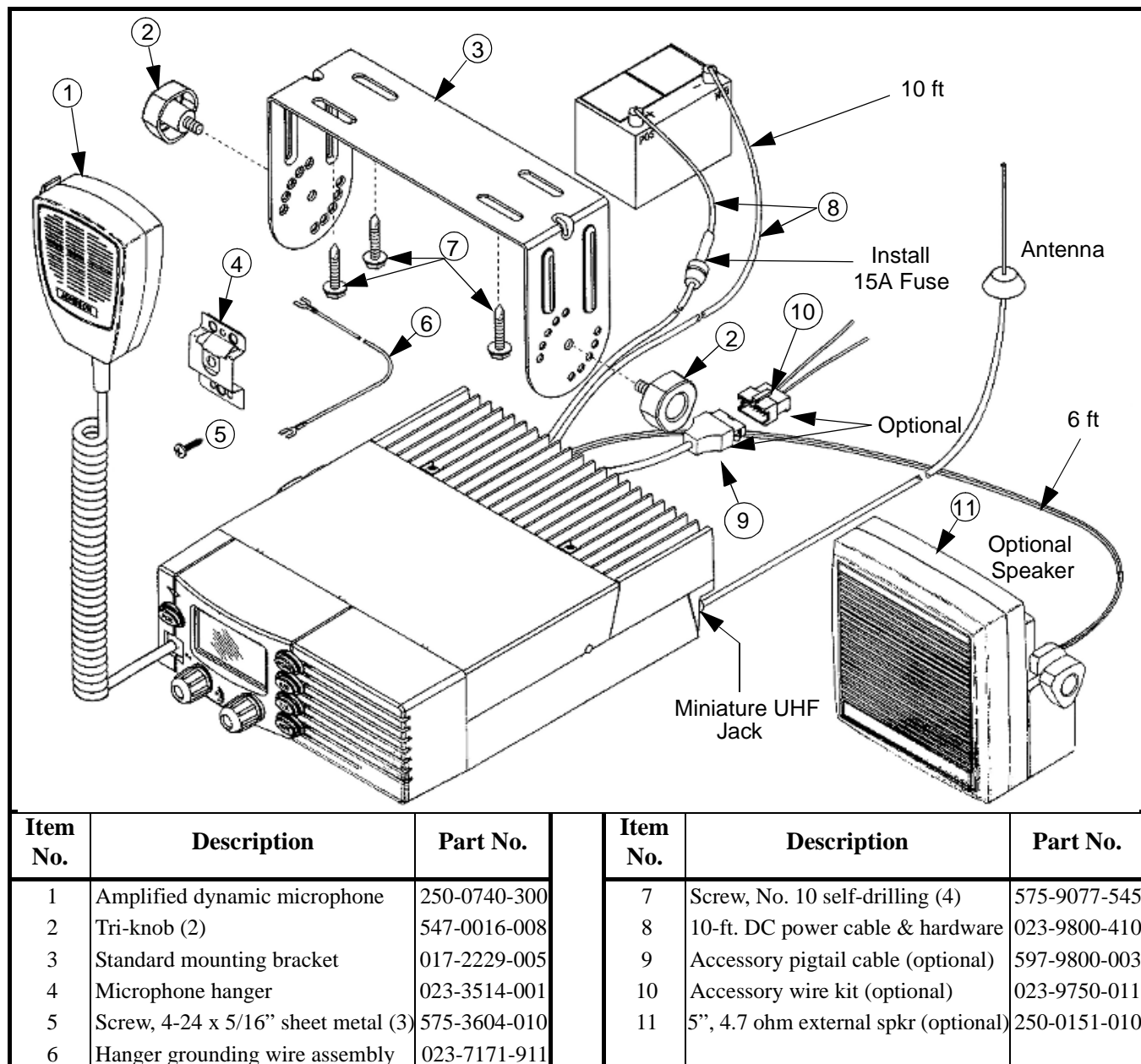

Figure 2-1 Front Mount Installation Components

2.1 GENERAL

2.1.2 PERFORMANCE TESTS

2.1.1 SCOPE OF INSTRUCTIONS

Since each installation is somewhat unique, the installation instructions which follow are intended only as a general guide to installing this transceiver.

Although each transceiver is carefully tested and aligned at the factory, it is good practice to verify transceiver performance before it is placed in service. Performance tests are located in Sections 7.5 and 7.6.

### 2.1.3 TRANSCEIVER PROGRAMMING

The transceiver needs to be programmed before it is placed in service unless it was ordered as factory programmed. Programming is described in Section 4. Transceivers are normally shipped with preprogrammed factory test channels and test parameters.

### 2.1.4 REQUIRED POWER SOURCE

This transceiver is designed for installation in vehicles which have a nominal 12-volt, negative ground electrical system (negative battery terminal connected directly to the chassis). If the vehicle has some other type of electrical system, a voltage converter is required.

## 2.2 MOUNTING THE TRANSCEIVER

### 2.2.1 SELECTING A MOUNTING LOCATION

Front mount transceivers are designed for mounting in a location within convenient reach of the operator such as the dash, console, or floor. Remote mount models are designed for mounting in a remote location such as under a seat or in the trunk that is up to 6 feet (or up to 17 feet with optional extension cable) from the control unit.

### WARNING

*The mounting location of the transceiver or control unit can affect safe operation of the vehicle. Follow these precautions when mounting this transceiver:*

- Mount it where it does not interfere with operation of the vehicle controls.
- Mount it where the operator can easily see the display and reach the controls.
- Mount it where it will be least likely to cause injury in case of an accident.
- Airbags deploy with great force. Therefore, do not mount it anywhere near the deployment area. In

addition, do not place any other objects in the deployment area.

### 2.2.2 INSTALLATION COMPONENTS

The following mounting kits are used to install the transceiver. These components and other components are shown in Figure 2-1.

#### Mounting Kit, Part No. 023-9800-030

- Two tri-knobs for attaching the transceiver to the mounting bracket
- Four No. 10 self-drilling screws

#### Universal Cable and Hardware Kit

Part No. 023-9800-410 (10 ft)  
Part No. 023-9800-422 (22 ft)

- 10 ft or 22 ft fused power cable
- Microphone clip and ground wire
- One 7A and one 15A fuse (7A not used)

### 2.2.3 ATTACHING MOUNTING BRACKET

Either Standard Mounting Bracket, Part No. 017-2229-005, or Low Profile Mounting Bracket, Part No. 017-2229-010, can be used to mount the transceiver. Proceed as follows:

1. Check the area underneath the selected mounting surface for such things as wires, electrical components, and brake and gas lines that could be damaged when the mounting bracket screws are installed. Then install the mounting bracket using the included self-tapping screws or other screws if desired.
2. Install the transceiver in the bracket using the included knobs.
3. With front mount transceivers, install the included microphone hanger in a convenient location using the included sheet metal screws or others. For proper operation of functions such as the monitor mode and scan, the hanger must be connected to chassis ground. If required, ground the hanger using the included ground wire.



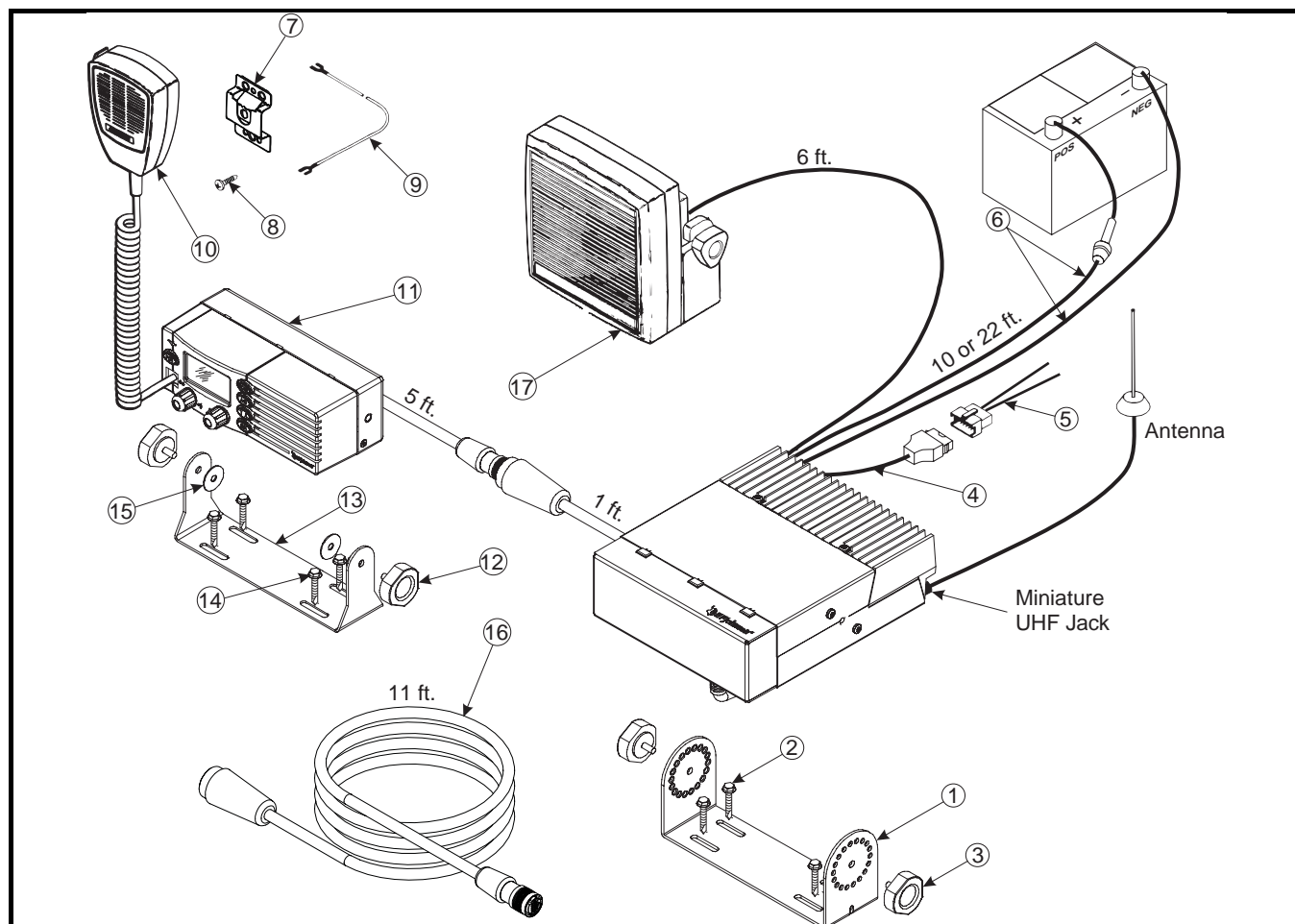

Item No.	Description	Part No.	Item No.	Description	Part No.
1	Low profile mounting bracket	017-2229-010	9	Hanger ground wire assembly	023-7171-911
2	Screw, No. 10 self-drilling (4)	575-9077-545	10	Amplified dynamic microphone	250-0740-300
3	Tri-knob (2)	547-0016-008	11	Remote control unit	---
4	Accessory pigtail cable (optional)	597-9800-003	12	Tri-knob (2)	547-0016-008
5	Accessory wire kit (optional)	023-9750-011	13	Mounting bracket, control unit	017-2227-057
6	10-ft. DC power cable & hardware	023-9800-410	14	Screw, No. 10 self-drilling (4)	575-9077-545
	22-ft DC power cable & hardware	023-9800-422	15	Flat washer, vulcanized (2)	596-6400-030
7	Microphone hanger	023-3514-001	16	Extension control cable, 11 ft (opt.)	597-9800-009
8	Screw, 4-24 x 5/16" sheet metal (3)	575-3604-010	17	5", 4.7 ohm external spkr (optional)	250-0151-010

Figure 2-2 Remote Mount Installation Components

### 2.3 POWER CABLE INSTALLATION

It is recommended that both wires of the power cable be connected directly to the vehicle battery. Connection of either wire to other points may result in increased interference from the vehicle's electrical system. If noise is still a problem with both wires connected to the battery, a noise filter should be used.

*NOTE: With LTR-Net models, do not connect the power cable to a switched power source such as the ignition switch or a relay. Always use the front panel power switch or the ignition sense input described in Section 2.4.3 to switch power. When power is switched externally with LTR-Net models, the de-registration message cannot be sent and the current user settings are not saved.*

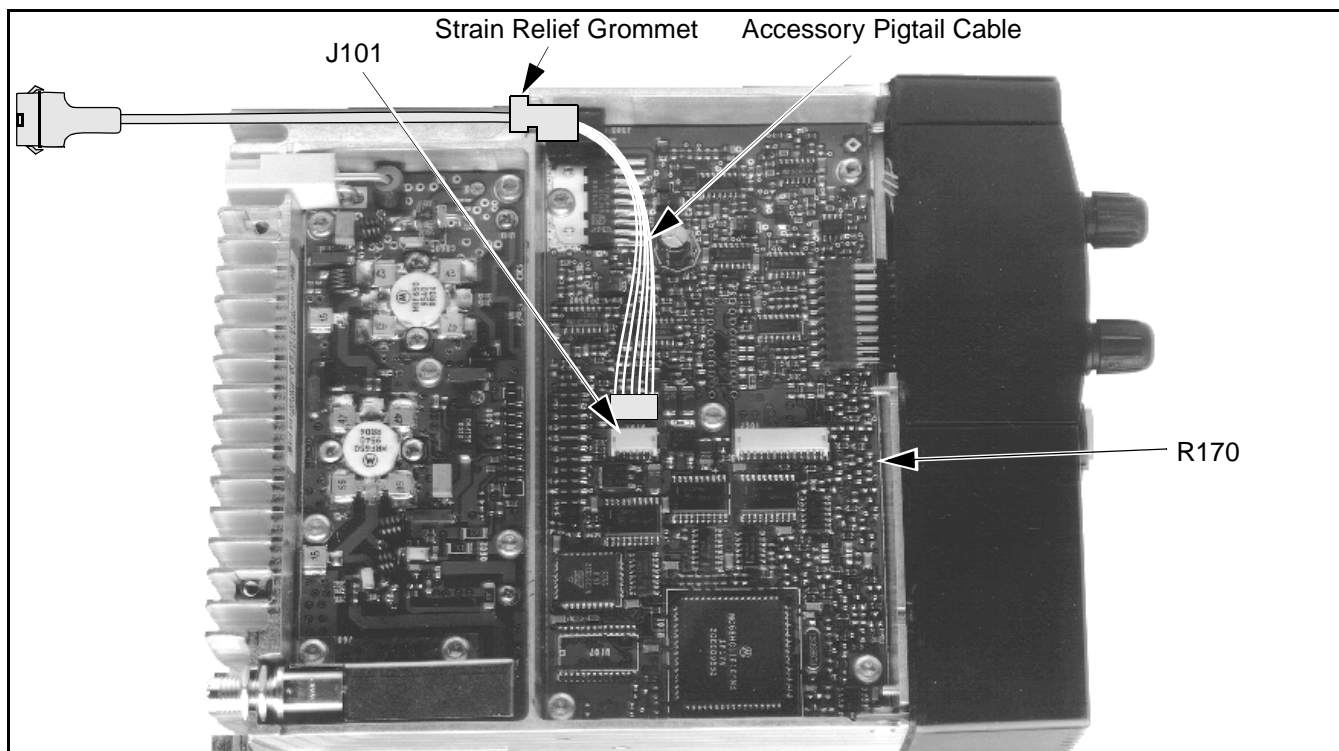

**Figure 2-3 Accessory Cable Installation**

Proceed as follows to install the power cable:

1. Before beginning power cable installation, remove the negative cable from the battery to prevent damage from accidental short circuits.
2. Route the red and blue wires of the power cable to the vehicle battery. You may need to cut the cable if it must be routed through an opening that is not large enough to clear the fuseholder. The -422 kit includes butt splice connectors that can be used to splice the cable back together.
3. Connect the red power cable to the positive (+) battery terminal. To minimize the chance of a short circuit occurring in an unfused part of the power cable, the fuseholder should be as close as possible to the battery terminal.
4. Connect the blue power cable wire to the negative (-) battery terminal.
5. Both 7- and 15-ampere fuses are included with the power cable. Install the 15-ampere fuse in this application.

6. Plug the power cable into the transceiver and reconnect the negative battery cable.
7. Install the antenna according to the manufacturer's instructions. This transceiver has a miniature UHF connector. If the antenna has some other type, an adapter is required. Check VSWR. Reflected power should be less than 4% of forward power (VSWR less than 1.5 to 1).

## 2.4 ACCESSORY CABLE INSTALLATION

### 2.4.1 GENERAL

If transceiver power is to be controlled by the vehicle's ignition switch, a horn alert installed, or other accessory connector outputs utilized, the optional accessory pigtail cable is installed in the transceiver (see Figure 2-1). Also required is the accessory wire kit which includes two 8-pin connectors which plug into the pigtail cable, two 22-ft and three 2-ft wire assemblies, and a fuseholder assembly. These components are installed as required for each application. Proceed as follows to install this cable.

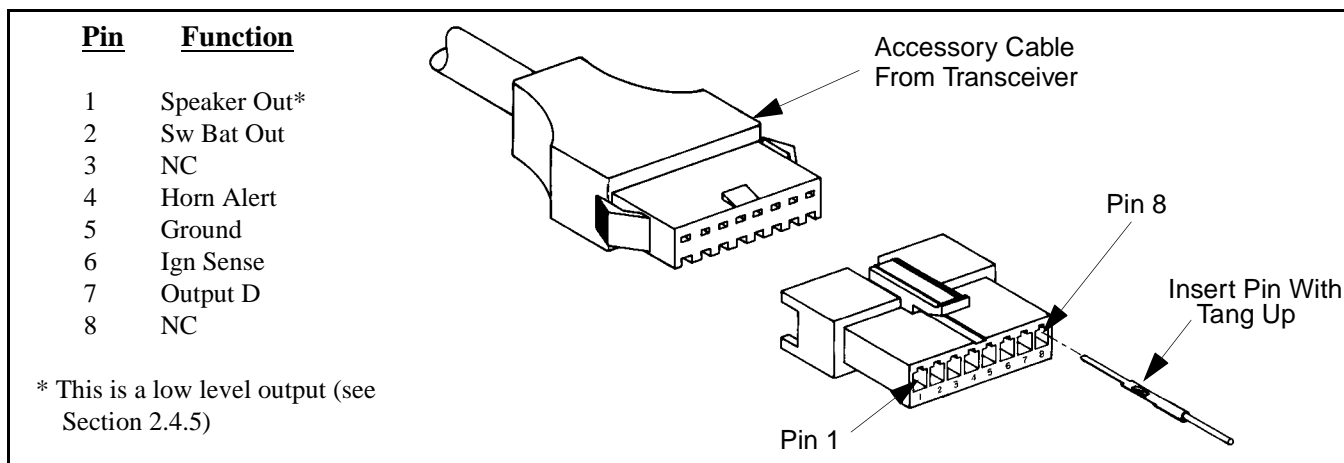

**Figure 2-4 Accessory Cable Connector**

### 2.4.2 ACCESSORY PIGTAIL INSTALLATION

1. Remove the bottom cover of the transceiver to access the audio/logic board.
2. Plug the pigtail cable from the kit into J101 as shown in Figure 2-3. The plug can be inserted only one way.
3. Position the strain relief in the external speaker jack slot of the chassis (see Figure 2-3).
4. If installing the ignition sense function, proceed to the next section to remove R170. Otherwise, reinstall the bottom cover.

- The horn alert (LTR-Net/Multi-Net) may be automatically disabled when the ignition switch is on.
- A transceiver power turn-off delay can be programmed. Standby current (receive mode, audio squelched) is about 1 ampere.
- With LTR-Net models, the de-registration message is sent and settings saved (see NOTE on page 2-3).

### 2.4.3 CONNECTING IGNITION SENSE WIRE

*NOTE: If the ignition sense function is not used, no transceiver modifications are required and this section can be skipped. However, then be sure that the Ignition Sense Delay Time is set to "Forever/Infinite". If it is not, improper transceiver operation may result when starting the vehicle.*

#### General

When the ignition sense line is connected, the following additional functions are provided:

- The transceiver turns on and off with the vehicle ignition switch (if the front panel power switch is on).

#### Removing R170

When the ignition sense function is used, resistor R170 on the audio/logic board must be removed. The general location of this resistor is shown in Figure 2-3, and the exact location is shown in Figure 2-5. Carefully remove R170, taking care not to damage board traces or adjacent components.

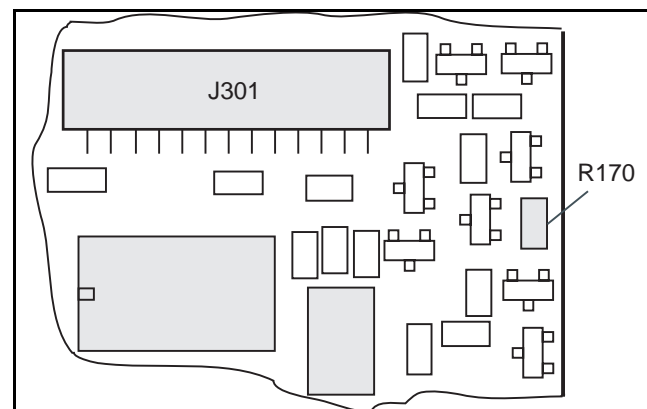

**Figure 2-5 R170 Location Diagram**

### Installing Ignition Sense Wire Assembly

The ignition sense input is connected using the connector with the 22-foot red wire pre-installed in pin 6. The white jumper between pins 1 and 3 is not used with this transceiver, so it can be clipped off or left as is. It is used only Summit® or Viking® HT/GT transceivers to route audio to the internal speaker. The other connector and wire assemblies in the kit can also be used if desired.

The red wire from pin 6 (see Figure 2-4) is connected to a 13.6-volt source that is switched by the vehicle ignition switch. Connect this wire using the included fuseholder and 1-amp fuse. Be sure to install the fuse as close as possible to the connection point so that it provides optimum short circuit protection.

#### 2.4.4 CONNECTING HORN ALERT WIRE

*NOTE: The horn alert feature is not available with SMARTNET/SmartZone models.*

To utilize the horn alert, the horn alert output of the accessory connector is connected and special programming is required. When the horn alert sounds, pin 4 of the accessory connector goes low. The disabled condition is a high impedance state.

Maximum sink current of the horn alert output is 500 mA. Therefore, some type of horn alert driver circuit is usually required. If connecting to a relay, a diode should be connected across the relay coil with the cathode toward the battery side. This protects Q100 on the audio/logic board when the relay de-energizes.

The horn alert output is connected by using one of the 22- or 2-foot wire assemblies included in the Accessory Wire Kit. Insert the pin of the wire assembly into the pin 4 slot of the connector as shown in Figure 2-4. Then connect the other end to the horn alert driver.

#### 2.4.5 OTHER ACCESSORY CABLE OUTPUTS

**Speaker Output (pin 1)** - This is a low-level, volume controlled, speaker output. It provides drive to an external device such as an audio power amplifier. The input impedance of the external device should be greater than 20k ohms.

For this output to operate properly, the audio amplifier requires an 8-ohm load. Therefore, if not using the internal speaker and no speaker is connected to the external speaker jack, connect an 8-ohm, 5-watt resistor to the external speaker jack.

**Sw Bat Out (pin 2)** - This output can provide a switched battery output current of up to 1.5 A (including the current supplied to the microphone connector). This current is limited by fuse F100 on the audio/logic board. *CAUTION: Do not change this fuse to one with a higher current rating because PC board damage may result.*

**Horn Alert (pin 4)** - See Section 2.4.4.

**Ignition Sense (pin 6)** - See Section 2.4.3.

**Output D (pin 7)** - This output is available with LTR-Net/Multi-Net models only. It is controlled by the menu OPTION parameter or by an option switch programmed for that function. It can also be controlled by several I/O functions (see Appendix B).

### 2.5 REMOTE CONTROL UNIT INSTALLATION

#### 2.5.1 GENERAL

*NOTE: Install the remote mount transceiver, power cable, and accessory cable as described in Sections 2.2, 2.3, and 2.4, respectively.*

No special control unit programming or PC board modifications are required prior to installing the remote control unit. An diagram showing a remote installation is located in Figure 2-2. As indicated in this diagram, the control unit has a 5-ft pigtail cable and the transceiver has a 1-ft pigtail cable. These cables can be directly connected if the control unit is mounted within approximately 6-ft of the transceiver. Otherwise, the optional 11-ft extension cable can be used to allow a mounting distance of up to approximately 17 feet.

#### 2.5.2 MOUNTING REMOTE CONTROL UNIT

1. Check the area underneath the selected mounting surface for such things as wires, electrical components, and brake and gas lines that could be damaged when the mounting bracket screws are

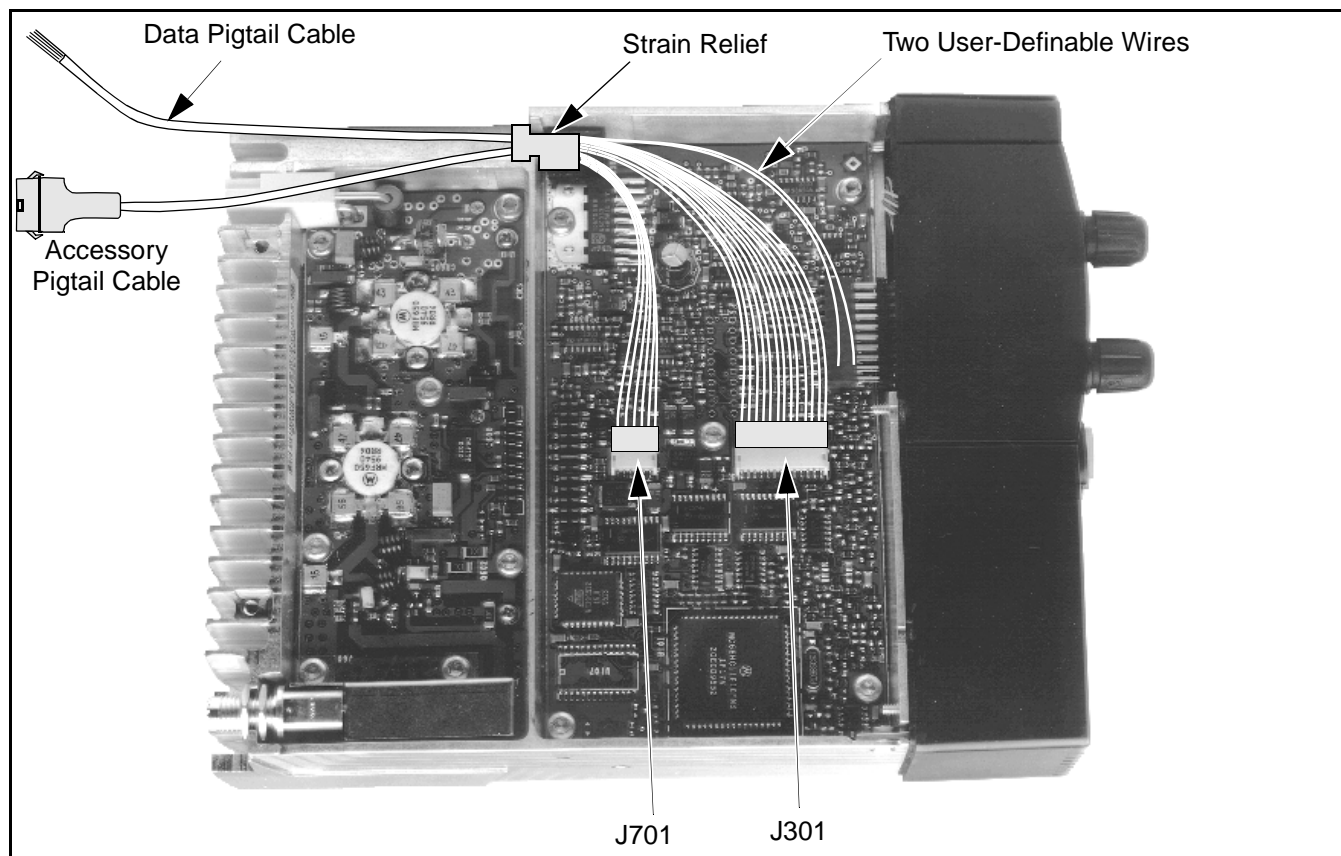

**Figure 2-6 Data Cable Installation (-001 Cable Shown)**

installed. Then install the mounting bracket using the included self-tapping screws or other screws if desired.

2. Install the control unit in the bracket using the included knobs and vulcanized washers (the washers are installed between the bracket and control unit).
3. Install the included microphone hanger in a convenient location using the included sheet metal screws or other screws. For proper operation of functions such as the monitor mode and scan, the hanger must be connected to chassis ground. If required, ground the hanger using the included ground wire.

## 2.6 USING AN EXTERNAL SPEAKER

Power output with the internal 8-ohm speaker in the front panel or remote control unit is approximately 3 watts. For up to 5 watts of power, a 4.7-ohm external speaker can be used. This speaker is plugged into the external speaker jack on the back of the transceiver. This is a standard 1/8", two-conductor phone jack. The

internal speaker is automatically disabled when an external speaker is used.

The impedance of the external speaker must not be less than 4.0 ohms. Using a speaker with an impedance less than 4.0 ohms could result in audio amplifier U306 overheating and does not provide 5 watts of power. Therefore, to allow for tolerances, a speaker with a nominal impedance of 4.7 ohms is recommended. The E.F. Johnson remote speaker listed in Figure 2-1 or Table 1-3 meets this requirement. This speaker has a 6-ft cable, and in some applications (such as remote mounting) an extension cable may be required to connect it to the transceiver.

## 2.7 DATA CABLE INSTALLATION

### **CAUTION**

*DO NOT* apply power a transceiver that has one of the data cables installed without first properly terminating the wires of that cable. These wires carry differing potentials and transceiver damage may result if they inadvertently contact each other.

### 2.7.1 GENERAL

The optional data pigtail cable is supported by Multi-Net versions only. It is installed when a modem or some other type of data device is to be connected to the transceiver. This cable connects the data equipment to data connector J301 on the audio/logic board. Two data cables are available (see Table 1-3), and descriptions of each follow.

Data/Accessory Pigtail Cable, Part No. 597-9800-001

This cable is a combination data and accessory pigtail cable. It does not include a connector for interfacing with the data equipment. The wires are unterminated and connected to a user-supplied connector as desired. The cable has 15 conductors. All 13 pins of J301 are brought out, and there are two additional wires that can be connected inside the transceiver as desired.

Data Pigtail Cable, Part No. 597-9800-005

This is a data cable only (it does not include the accessory cable). The data cable is similar to the one included with the -001 cable. It has 15 unterminated wires, and a user supplied connector is installed as desired.

### 2.7.2 DATA CABLE INSTALLATION

1. Remove the bottom cover of the transceiver to access the audio/logic board.
2. Refer to Figure 2-6 and plug the 13-pin connector of the data cable into J301. If also installing the accessory cable, plug the 7-pin connector into J701. Refer to Section 2.4 for more accessory cable installation information.
3. Refer to the wiring chart in Table 2-1 and connect the data cable wires to the user supplied connector as required for the data equipment being used.
4. If required, install the purple and pink wires to the desired points in the transceiver.
5. Position the strain relief grommet of the accessory/data cable in the external speaker jack slot of the chassis as shown in Figure 2-6 and reinstall the bottom cover.

**Table 2-1 Data Cable Wire Chart**

J301 Pin No.	Function	Wire Color
1	Sw Bat Out	White
2	Rx Filt Out	Green
3	Tx Filt In	Yellow
4	TxD	Blue
5	RxD	Orange
6	Transmit	Gray
7	IN2	Brown
8	Ext Serv Req	White/Red
9	Option 1	White/Green
10	Output C	White/Black
11	Ext Pwr Sw	White/Blue
12	8V Out	Red
13	Ground	Black
NC	User Defined	Purple
NC	User Defined	Pink

### 2.8 KEY CAP KITS

*NOTE: To remove a key cap, insert a tool with a sharp tip in the slot on the bottom of the cap and carefully pry against the front panel to release the cap.*

Key Cap Kit, Part No. 587-9840-001, is standard with each LTR and Multi-Net transceiver and includes the five caps indicated below.

**FCN      SCAN      A/D      TA      AUX**

An optional key cap kit, Part No. 587-9840-004, is also available which includes all of the caps in the following list:

<b>FCN</b>	<b>SCAN</b>	<b>A/D</b>	<b>ROAM</b>	<b>TEL</b>
<b>TA</b>	<b>AUX</b>	<b>HOME</b>	<b>PAGE</b>	<b>HORN</b>
<b>C/G</b>	<b>PRI</b>	<b>USR1</b>	<b>USR2</b>	<b>MON</b>
<b>CPND</b>	<b>MHNG</b>	<b>STLH</b>	<b>MICPA</b>	<b>BANK</b>
<b>EMER</b>	<b>ENCPT</b>	<b>Rx PA</b>	<b>CALL</b>	
<b>(Blank)</b>	<b>(Blank)</b>			

### SECTION 3 OPERATION

*NOTE: This section describes the operation of LTR models. The operation of LTR-Net models is different and is described in a separate addendum.*

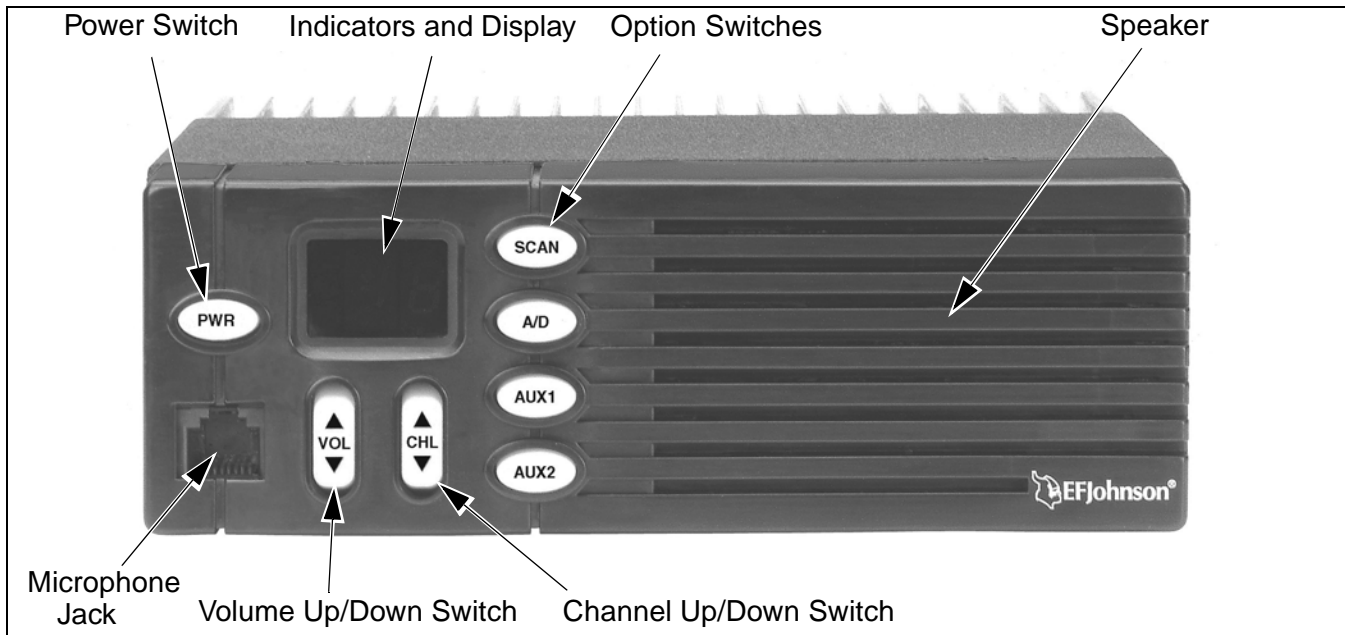

**Figure 3-1 Front Panel Controls and Indicators (Low-Tier)**

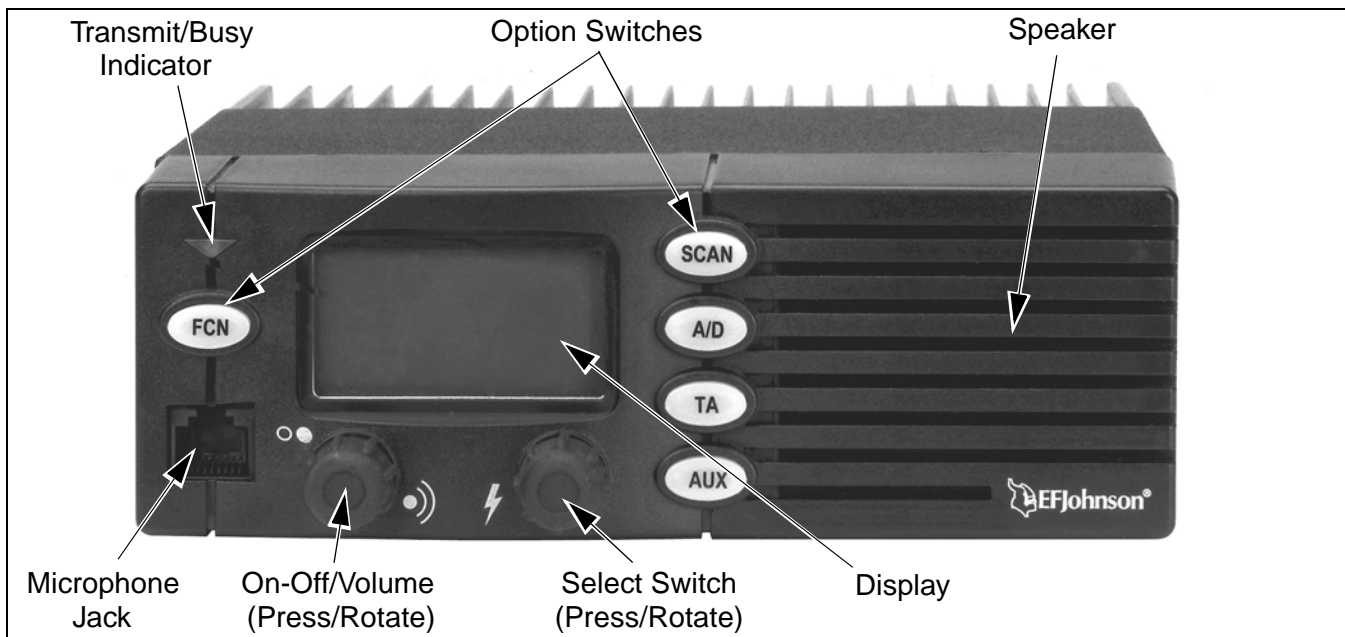

**Figure 3-2 Front Panel Controls and Indicators (High-Tier)**

#### 3.1 FEATURES

The features available with low and high tier transceivers are shown in Table 3-1. The LTR features are available when a system programmed for LTR

operation is selected. Likewise, the conventional features are available when a system programmed for conventional operation is selected. Most features can be enabled or disabled by programming.

Table 3-1 Low and High Tier Features

Feature	Low Tier	High Tier
<b>General Features</b>		
Up to 16 system/group combinations programmable	X	
Up to approximately 40 16-group systems or 100 1-group systems programmable		X
Up to 126 different channels programmable	X	
Up to 378 different channels programmable		X
Each system programmable for LTR or conventional operation	X	X
1.5-digit LED display	X	
Large 2-line x 8-character liquid crystal display (LCD) with backlight		X
Unique 8-character group alpha tags		X
Numeric system/group display mode		X
Alpha tag system/group display mode and display mode user selectable		X
System Scan	X	X
Group Scan		X
User programmable scan list(s)	X	X
Bank Select (up to 16 banks of systems programmable)		X
Two programmable option switches (AUX1/AUX2)	X	
All five option switches programmable		X
Menu mode		X
Emergency switch		X
Stealth mode to disable LED, tones, and backlight		X
Proceed (clear-to-talk) tone	X	X
Time-out timer with penalty timer	X	X
Call indicator	X	X
Receive-only channels	X	X
Horn alert with fixed on-off times and cycles	X	
Horn alert with programmable on-off times and cycles		X
Companding (optional)	X	X
Encryption (optional)	X	X
Two accessory option slots	X	X
One of two power output levels programmable for each system	X	
One of five power output levels programmable for each system		X
Limited I/O line programmability; external serial transceiver control not available	X	
Complete I/O line programmability; external serial transceiver control standard		X
<b>LTR Features</b>		
Busy queuing (telephone calls only)	X	X
System search (telephone calls only)	X	X
Transpond	X	X
Transmit inhibit	X	X
Receive priority ID codes	X	X
<b>Conventional Features</b>		
Each group selects a radio channel	X	X
Each channel programmable for tone (CTCSS) or digital (CDCSS) Call Guard, carrier, or "ANDed" external squelch control	X	X
First and second priority channel sampling with Call Guard squelch detect	X	X
User-adjustable squelch level	X	X
Busy indicator		X
Transmit disable on busy	X	X
Monitor mode	X	X
Repeater talk-around	X	X



## 3.2 CONTROLS

### 3.2.1 LOW TIER CONTROLS

The low tier transceiver is shown in Figure 3-1, and the controls operate as follows.

**PWR Switch** - Pressing this switch turns power on and off. The current state of this switch is stored by a capacitor for approximately a week. Therefore, if power is removed from the transceiver (such as if power is switched by a relay), the selected state does not change. The vehicle ignition switch may also control power as described in Section 3.5.12.

**VOL Up-Down Switch** - Pressing the upper part of this switch increases the volume by one step and pressing the lower part decreases it by one step. Holding the switch down causes the function to repeat. The volume is adjustable in 64 steps (see Section 3.4.2).

**CHL Up-Down Switch** - Pressing the upper part of this switch increases the selected channel (system/group) by one and pressing the lower part decreases it by one. After the highest programmed channel is displayed, the wrap-around tone sounds and the display rolls over to the lowest programmed channel and vice versa. Holding the switch down causes the function to repeat.

*NOTE: Any of the following four switches can be disabled by programming if desired.*

**Scan Switch** - Turns system scanning on and off (see Section 3.7).

**A/D (Add/Delete) Switch** - Programs the system scan list. The displayed system/group is *not* in the scan list (not scanned) when “-” is indicated on the left side of the display (see Section 3.7.2).

**AUX1, AUX2 (Auxiliary) Switches** - These switches can be programmed to control two of the following features (see Section 3.5.1):

- Encryption
- Horn alert
- Home system/group
- Monitor
- Option (dealer installed)
- Priority sampling (conventional only)

- Squelch adjust
- Talk-around

**Microphone Jack** - Connection point for the microphone and also the RPI programming interface when programming the transceiver.

**Microphone Push-To-Talk (PTT) Switch** - Keys the transmitter.

**Speaker** - A speaker is located behind the grille. An optional speaker can be connected to the external speaker jack (see Section 3.2.3). The internal speaker is disabled when an external speaker is used.

### 3.2.2 HIGH TIER CONTROLS AND INDICATOR

The high tier transceiver is shown in Figure 3-2. The high tier option switches are all programmable, so the function of each switch can vary from those shown. The controls and indicators operate as follows:

**On-Off/Volume** - Pressing the knob turns power on and off. The vehicle ignition switch may also control power as described in Section 3.5.12. Rotating this knob sets the volume level (see Section 3.4.2).

**Select Switch** - This switch changes the selected system or group and is also used in the menu mode (see Section 3.6) and other times. When changing the system/group, turning this switch clockwise increases the selected system or group, and turning it counter-clockwise decreases the selected system or group. To switch between system and group select, press this switch. Refer to Section 3.4.5 for more information.

This control also has two alternate functions that are selected by first pressing the FCN option switch. Refer to Section 3.5.8 for more information.

**Tri-Color Indicator** - Indicates the following conditions:

Red - Transmitter keyed, normal power output

Orange - Transmitter keyed, power reduced by thermal foldback circuit

Green - Busy conventional channel (carrier detected).

If this indication appears but no message is heard and Call Guard squelch is programmed, a call for someone else was probably detected.

**Microphone Jack** - Connection point for the microphone and also the RPI programming interface when programming the transceiver.

**Microphone Push-To-Talk (PTT) Switch** - Keys the transmitter.

**Speaker** - A speaker is located behind the grille. An optional speaker can be connected to the external speaker jack described in Section 3.2.3. The internal speaker is disabled when an external speaker is used.

### Option Switches

As previously mentioned, all high tier option switches are programmable, and the functions that can be programmed are as follows. Refer to Section 3.6 for more information on option switch and menu functions:

- Add/delete (system and group scan list prog)
- Call Guard squelch disable
- Emergency
- Encryption
- Function (see following description)
- Horn alert
- Monitor
- Option (dealer installed)
- Priority sampling (conventional only)
- Scan on-off
- Stealth mode select
- Talk-around (conventional only)
- Not used (disabled)

### 3.2.3 REAR PANEL JACKS AND CONNECTORS

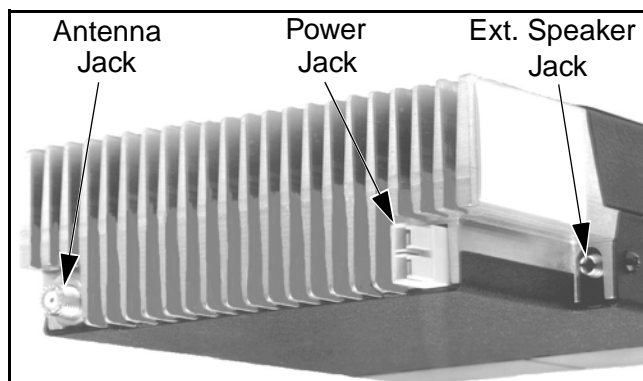

**Antenna Jack** - Miniature UHF jack for connecting the antenna.

**Power Jack** - Connection point for a nominal 12-volt, negative ground power source.

**Speaker Jack** - Connection point for an external 4.7-ohm, 5-watt speaker. The internal speaker is disabled when a speaker is connected to this jack.

**Accessory Cable (Not Shown)** - This optional pigtail cable installs in the speaker jack opening and is used to connect the ignition sense, horn alert, and other outputs (see Section 2.4).

**Data Cable (Not Shown)** - This optional cable also installs in the speaker jack opening, and it is used to connect data equipment such as a modem to the transceiver (see Section 2.7).

## 3.3 DISPLAY DESCRIPTION

### 3.3.1 LOW TIER DISPLAY

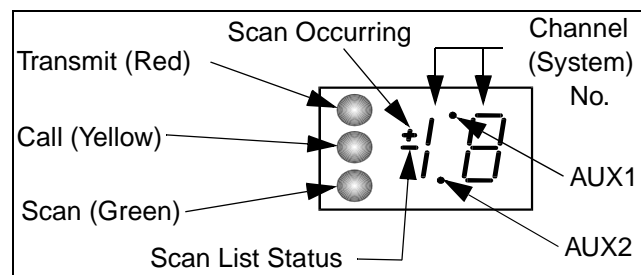

**Figure 3-3 Low Tier Display and Indicators**

**Channel Display** - This 1.5-digit LED display indicates the selected system (channel) from 1-16. It also indicates certain error conditions. The left digit can display only "1" as shown above.

**Transmit Indicator (Red)** - Indicates that the transmitter is keyed.

**Call Indicator (Yellow)** - Indicates that a call has been received on a channel programmed for a call indicator (see Section 3.5.3). To turn this indication off, press any key.

**Scan Indicator (Green)** - Indicates that system scanning has been enabled (see Section 3.7).

" + " - Indicates that scanning is occurring.

" - " - Indicates that the displayed system/group (channel) is *not* in the scan list (not scanned).

**Upper Decimal Point** - Indicates that the function controlled by the AUX1 switch is enabled.

**Lower Decimal Point** - Indicates that the function controlled by the AUX2 switch is enabled.

### 3.3.2 HIGH TIER DISPLAY

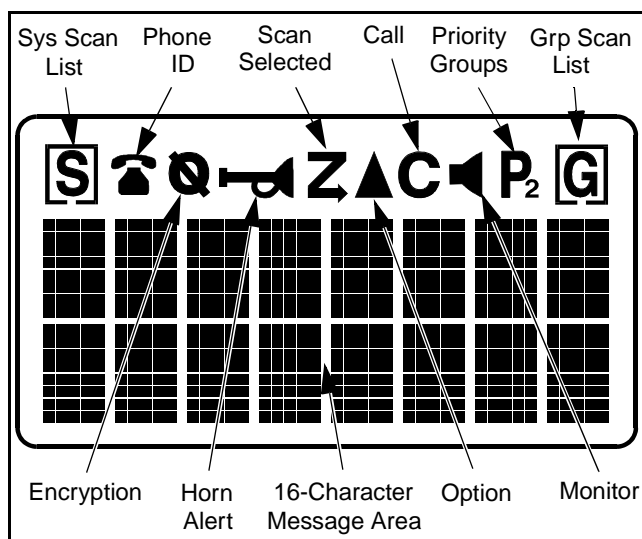

**Figure 3-4 High Tier Display**

**16-Character Message Area** - Indicates the selected system and group (see Section 3.4.4), error conditions, and status information (see Section 3.10.3).

**S** - Indicates that the displayed system is in the scan list (scanned normally).

**G** - Indicates that the displayed group is in the scan list (scanned normally).

**Phone icon** - Indicates that the selected group is programmed for telephone calls (LTR systems only).

**Q** - Indicates that optional encryption is enabled (see Section 3.5.7).

**Horn icon** - Indicates that the horn alert is enabled (see Section 3.5.10).

**Z** - Indicates that scanning is enabled (see Section 3.7).

**▲** - When an option switch is programmed to control a dealer installed accessory (option), indicates that it is enabled (see Section 3.5.11).

**C** - Indicates that a call has been received on a group programmed for a call indicator (see Section 3.5.3). To turn this indication off, press any key.

**Speaker icon** - Indicates that the monitor mode is enabled. This mode disables Call Guard squelch and other squelch control features so that all messages are heard on conventional systems (see Section 3.9.1).

**P<sub>2</sub>** - When only **P** is displayed, the selected or displayed conventional group is scanned as a first priority group. When **P<sub>2</sub>** is displayed, it is scanned as a second priority group (see Section 3.9.6).

## 3.4 GENERAL OPERATION

### 3.4.1 POWER-UP SEQUENCE

When transceiver power is turned on by pressing the front panel power switch or turning the ignition switch on, the following start-up sequence occurs:

#### Low Tier Models

1. All segments and indicators in the display are enabled for 1 second.
2. A beeps sounds (if tones are enabled) and the transceiver is ready to be used.

#### High Tier Models

1. The backlight turns on.
2. All segments in the display are briefly enabled.
3. The last seven digits of the transceiver part number (see Section 1.3) are displayed on the top line very briefly. For example, a high tier, 800 MHz, 30-watt, LTR transceiver is indicated as “9883203”. The eighth display digit is reserved for future use and is always “0”.
4. A beeps sounds (if tones are enabled) and the transceiver is ready to be used.

### 3.4.2 DETERMINING VOLUME LEVEL

The relative volume setting can be determined by noting the position of the index on the volume knob

(high tier models only). It may also be possible to enable a reference tone or audio for setting the volume level using one of the following methods:

- If key press tones have been enabled as described in Section 3.5.17, a short tone can be enabled by rotating the select switch (high tier models) or pressing an option switch.
- If a conventional system is selected, take the microphone off-hook to enable the monitor mode. If someone is talking, audio is then heard. If nobody is talking, the squelch control can also be adjusted as described in Section 3.4.6 and noise should be heard. Refer to Section 3.9.1 for more information on the monitor mode. When an LTR system is selected, the receiver cannot be manually unsquelched.

### 3.4.3 BACKLIGHT OPERATION

With high tier models, the display and keypad backlight can be controlled by the menu BACK-LIGHT parameter. The three states that can be selected are Bright, Dim, and Off. It is in the selected condition whenever power is turned on. If this menu parameter has been disabled by programming, the backlight is fixed in one of these states (see Section 3.6.5).

### 3.4.4 SYSTEM/GROUP DISPLAY INFORMATION

#### Low Tier Models

The display indicates the selected system/group combination from 1-16. These combinations are also referred to as channels with this transceiver. Any 16 combinations of up to 16 systems with up to 16 groups each can be programmed. There is no separate group select function.

The specific system/group selected by each display number is assigned by programming a channel table. For example, “1” may select System 1/Group 1, “2” System 2/Group 1, “3” System 1/Group 2, and so on. Group alpha tags are not displayed with this transceiver.

#### High Tier Models

Up to 100 systems and up to 16 groups per system can be selected by high tier models. Either the numeric display mode or the alpha tag mode can be selected. The display mode is user selectable if the S/G DISPLAY menu parameter is enabled (see Section 3.6.2). Otherwise, it is fixed by programming.

When the numeric mode is selected, the selected system and group numbers are indicated on the top line of the display as Sxx and Gxx, and the group alpha tag (up to eight characters) is displayed on the bottom line. For example, System 1, Group 2 (CAR 220) is displayed as follows:

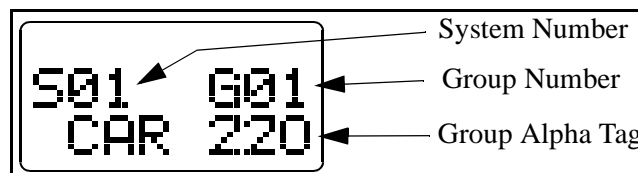

**Numeric Display Mode**

When the alpha tag mode is selected, the system alpha tag is displayed on the top line, and the group alpha tag is displayed on the bottom line. For example, a “SECURITY” system and “Car 220” group are displayed as follows:

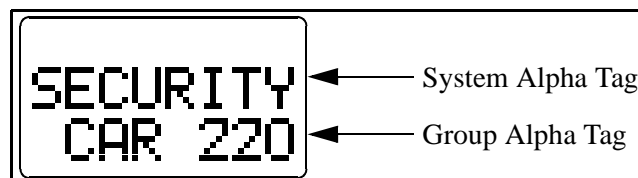

**Alpha Tag Display Mode**

### 3.4.5 SELECTING SYSTEMS AND GROUPS

#### Low Tier Models

As stated in the preceding section, sixteen system/group combinations are selectable, and each is indicated by a number in the display. To change the selected system/group, press the CHL up/down switch. Pressing the upper switch increases the number, and pressing the lower switch decreases the number. Holding a switch down causes the function to repeat.

After the highest programmed number is displayed, wrap-around to the lowest programmed number occurs and vice versa. The wrap-around tone sounds when this occurs (if tones are enabled).

High Tier Models

The front panel Select switch is used to change the system and group. Rotating this switch clockwise increases the system or group, and rotating it counter-clockwise decreases the system or group. After the highest system or group is selected, wrap-around to the lowest system or group occurs and vice versa. The wrap-around tone sounds when this occurs (if tones are enabled).

Pressing the Select switch toggles between the system and group select modes. With the numeric display mode (see preceding section), the active mode is indicated by an arrow in the display. This arrow points to “Sxx” when the system select mode is enabled, and to “Gxx” when the group select mode is selected (see following example).

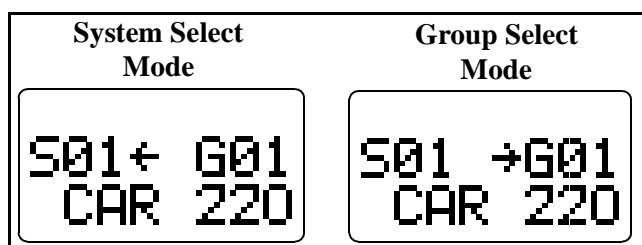

Select Mode Indicator (Numeric Display Mode)

If the alpha tag display mode is selected (high tier models only), the system or group select mode is indicated by an underline in the left-most character position. This underline is on the system alpha tag line when the system select mode is selected, and on the group alpha tag line when the group select mode is selected (see following example).

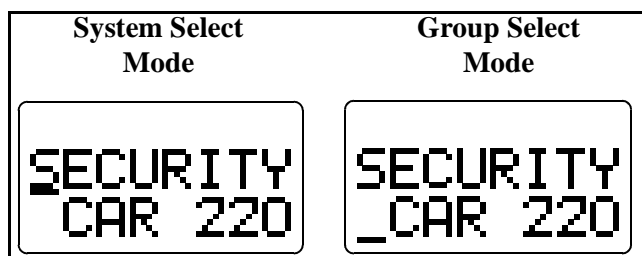

Select Mode Indicator (Alpha Tag Display Mode)

Programming of the “Select Knob Default” parameter determines if the transceiver reverts to the system or group select mode. For example, if it is programmed for the group select mode, it is in the group select mode when power is turned on and returns to that mode when the programmed delay timer expires. This timer starts when a change is made, and it is programmable for 0-15 seconds. When “0” is programmed, the transceiver remains in the last selected mode until power is cycled. Then default mode is then selected.

3.4.6 SETTING SQUELCH CONTROL

The squelch level for LTR operation is set during transceiver alignment and cannot be reset by the user. However, the squelch level for conventional systems can be set by the user as described in the following information. If the squelch level cannot be changed by the user (not recommended), a default level is used. With low tier models, the squelch level can be set by the user if the AUX1 or AUX 2 switch is programmed for the Squelch function. With high tier models, the FCN switch must be enabled.

With dual band (12.5/25 kHz) models, separate levels are maintained for each band. Adjusting the squelch with a 12.5 kHz channel selected sets the 12.5 kHz level, and adjusting it with a 25 kHz channel selected sets the 25 kHz level. Proceed as follows:

1. Select a conventional system, and a non-busy group programmed for carrier squelch. If the group is programmed for Call Guard squelch, the monitor mode described in Section 3.9.1 must also be enabled.
2. With low tier models, press AUX1 or AUX2 (whichever is programmed for squelch adjust) so the appropriate decimal point is lighted. Then within 8 seconds, press the CHL down switch until noise is heard and then press the CHL up switch until the noise just mutes.
3. With high tier models, press the FCN switch and then within 8 seconds rotate the Select switch as you would a normal squelch control. Rotate it counter-clockwise until noise is heard and then rotate it clockwise slightly past where the noise just mutes. The squelch adjust mode is indicated by

“SQUELCH” on the top line of the display, and the relative squelch level is indicated by a bar graph on the bottom line.

4. To select the current level and exit the mode, press the AUX1/AUX2 (low tier) or Select (high tier) switch again. This also occurs automatically 2 seconds after a change is made or 8 seconds after no activity.

*NOTE: Some readjustment may be required if weak messages are not heard or unsquelching occurs when no messages are present.*

### 3.4.7 LTR AND CONVENTIONAL OPERATING MODES

#### Introduction

This transceiver can be programmed to operate in the LTR and conventional modes. Each selectable system can be programmed for either of these modes. The operation that is programmed is determined by the type of repeater equipment being used. The differences in operation are described in the following information and also noted elsewhere as required.

#### LTR Operation

The LTR mode provides automatic channel selection (trunking) and monitoring before transmitting. Special tones and display messages indicate busy and out-of-range conditions, and telephone calls can be placed almost as conveniently as with your home telephone. The types of calls that can be placed are standard (mobile-to-mobile) and telephone. Standard calls are described in Section 3.8.4, and telephone calls are described in Section 3.8.5.

In the LTR mode, selecting a system selects a collection of groups and other information. Selecting a group selects transmit and receive ID codes and other information pertaining to that group such as Call indicator and horn alert operation. The ID codes determine the type of call (mobile-to-mobile or telephone) and the mobile or group of mobiles being called and what calls are received. The system may also be programmed with priority and block ID codes that allow additional calls to be received. For more infor-

mation on LTR features, refer to Section 3.8 and LTR Application Note, Part No. 009-0001-020, rev. 8 or later.

#### Conventional Operation

In the conventional mode, selecting a system selects a block of up to sixteen channels, and selecting a group selects the channel. Each channel (group) can be programmed for a different squelch control technique (CTCSS, CDCS, external decoder, or carrier) and other parameters. The squelch level must be adjusted as described in Section 3.4.6 to properly receive conventional calls.

With conventional operation, a busy condition is detected automatically if the Transmit Disable On Busy feature is used (see Section 3.9.2). Otherwise, it must be detected manually as follows. An out-of-range condition is not indicated by a special tone or display message because there is no data handshake with a repeater that allows this condition to be detected. Refer to Section 3.9 for more information on conventional operation.

To manually monitor a channel before transmitting to determine if it is being used by someone else, proceed as follows:

*NOTE: The busy indicator and monitor mode icon are not available with low tier models.*

**Using Busy Indicator (high tier only)** - With scanning disabled and the squelch control adjusted as described in Section 3.4.6, note if the indicator on the front panel is lighted green. If it is, a carrier is being detected on the currently selected conventional group (channel). If this indication is not present, the channel is not busy and the message can be transmitted.

**Using Monitor Mode** - If scanning, take the microphone off-hook to disable scanning and enable the monitor mode (indicated by  in the high tier display). The monitor mode can also be enabled by pressing an option switch programmed for the monitor function. The monitor mode disables squelch control features so that all messages are heard. If none are heard, the channel is free and the message can be transmitted. Refer to Section 3.9.1 for more information on monitoring.

If the transceiver is programmed to not detect an off-hook condition, taking the microphone off-hook does not disable scanning or enable the monitor mode. The option switch or the Transmit Disable On Busy feature must then be used to perform monitoring.

### 3.4.8 PLACING AND RECEIVING STANDARD (DISPATCH) CALLS

*NOTE: The following procedure applies to both LTR and conventional operating modes.*

Standard (dispatch) calls are between two or more mobile or control station transceivers. Unlike telephone calls, no number is dialed when the call is placed. Proceed as follows to place and receive a standard call:

#### Placing a Standard Call

1. Turn transceiver power on and set the volume and squelch as described in Sections 3.4.1 and 3.4.2. With conventional operation, also set the squelch as described in Section 3.4.6.
2. Select the system and group of the mobile being called as described in Section 3.4.5.
3. If a conventional call is being placed, monitor the channel manually or automatically as described in the preceding section.
4. The microphone PTT (push-to-talk) switch must be pressed (and held) to talk and released to listen. Operation with LTR and conventional systems is as follows:

#### **LTR Operation**

- If the proceed tone is enabled, it sounds when the system is successfully accessed. The proceed tone (and other tones) can be disabled if desired by the Tones menu parameter (high tier only) or by programming (see Section 3.5.17).
- If all repeaters are busy, the busy tone sounds (see Section 3.10) and “BUSY” is indicated on the lower line of the display (high tier only). If the PTT switch continues to be pressed, the system is accessed when it becomes available.

- If an out-of-range condition exists, the intercept tone sounds and “OUT-RNGE” is indicated on the lower line of the display (high tier only). No more access attempts are made when this indication appears. Drive closer to the radio system or away from shielding structures and try again.
- When responding, busy or out-of-range conditions may also occur as when placing a call because the system is accessed for each transmission.

#### **Conventional Operation**

- If the channel is busy and the Transmit Disable On Busy feature is programmed (see Section 3.9.2), “DSBL BSY” is indicated on the lower line of the display (high tier only), the busy tone sounds, and the transmitter is disabled.
  - Otherwise, busy and out-off-range conditions are not indicated (see Section 3.4.7) and speaking can begin when the PTT switch is pressed. If the proceed tone is enabled, it indicates when speaking can begin but does not indicate that a repeater has been successfully accessed (see Section 3.5.13).
5. When the call is finished, place the microphone back on-hook.

#### Receiving a Standard Call

1. Turn transceiver power on and set the volume and squelch as described in Sections 3.4.1 and 3.4.2.
2. Select or scan (see Section 3.7) the system and group programmed for the call you want to receive.
3. When the message is received, take the microphone off-hook and press the PTT switch to talk and release it to listen. If scanning, a response may not automatically occur on the group of call. Refer to Section 3.7.4 for more information.

### 3.4.9 PLACING AND RECEIVING TELEPHONE CALLS

The procedure for placing LTR telephone calls is described in Section 3.8.5. If telephone calls can be

placed in the conventional mode, the procedure used depends on the specific interconnect equipment being used.

### 3.5 GENERAL FEATURES

#### 3.5.1 AUX (AUXILIARY) SWITCH(ES)

##### Low Tier Models

The front panel AUX1 and AUX2 switches can each be programmed to control one of the features listed below. The other two option switches have fixed functions (SCAN and A/D) or are disabled by programming. When the function controlled by AUX1 is enabled, the upper decimal point is lighted, and when the function controlled by AUX2 is enabled, the lower decimal point is lighted.

- Encryption (see Section 3.5.7)
- Home system/group (see Section 3.5.9)
- Horn Alert (see Section 3.5.10)
- Monitor (see Section 3.9.1)
- Option, dealer-installed (see Section 3.6.16)
- Priority channel sampling (see Section 3.9.6)
- Squelch adjust (see Section 3.4.6)
- Talk-around (see Section 3.9.4)

##### High Tier Models

All five front panel option switches are programmable for any of the available functions. Any switch can also be disabled if desired. Refer to Section 3.6 for more information.

#### 3.5.2 BANK SELECT (HIGH TIER ONLY)

Up to sixteen banks can be programmed with high tier models. With low tier models, only one bank can be programmed, so multiple bank select is not available. Banks are collections of systems that have been set up by programming. For example, one bank could be programmed for operation in Minneapolis and another for operation in Milwaukee. Each bank is identified by a unique alpha tag.

Banks are selected by the BANK menu parameter (see Section 3.6.2). Rotate the Select switch to display "BANK SEL" on the top line, and then press the

Select switch to change the bank. The alpha tag of the current bank is displayed on the bottom line.

Any programmed system can be assigned to a bank, and the system numbering can be different for each bank. Only the systems in the currently selected bank are selected or scanned, and at least one bank is always programmed. Unique bank parameters include the default emergency system/group (see Section 3.5.6) and Home system/group (see Section 3.5.9).

When a different bank is selected, the last selected system in that bank is displayed, and the displayed group is the last selected group of that system. These are the only user selected functions that are stored on a per bank basis.

#### 3.5.3 CALL INDICATOR

With low tier models, the call indicator is the yellow LED to the left of the channel display (see Figure 3-1). With high tier models, it is "C" in the upper part of the display as shown in the following illustration.

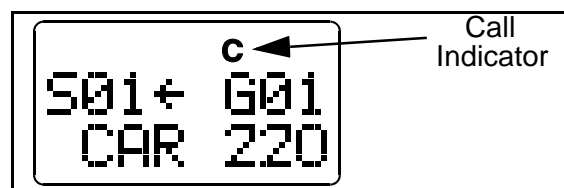

The purpose of this indication is to show that a call was received while the user was away from the vehicle. It is turned off by pressing any button or turning transceiver power off and then on. If scanning and the "last received" configuration is programmed (see Section 3.7.4), the system and group of the last call are displayed. Otherwise, the currently selected system/group is displayed.

With LTR systems, each selectable and the two fixed priority ID codes can be programmed to enable the call indicator. With conventional systems, each group can be programmed to enable it. The Call indicator is activated if the transceiver unsquelches for 2 seconds or longer. Therefore, if Call Guard squelch is programmed on a group, it must also be detected for the call indication to appear (unless it is disabled by the monitor mode).



### 3.5.4 COMPANDING

The companding feature is optional with this transceiver. It is a separate module that installs in Option Slot 2 (or 1) on the audio/logic board. Companding improves audio quality by decreasing the amount of noise present in the audio signal. It does this by providing a 2:1 compression of the audio signal on the transmit end and a 1:2 expansion on the receive end. Companding is especially recommended for 12.5 kHz bandwidth channels because audio quality improvement is usually significant.

If this feature is used, it must be utilized in both the transmitting and receiving mobile. The best results are obtained if companding is also used in the repeater; however, improvement also results if it is only used in the mobile and handheld transceivers. With telephone calls, companding must be utilized at the repeater if it is used in the mobile. Viking VX repeaters with the TIC module support companding, but others may not.

Each LTR and conventional system can be individually programmed for companding. Then whenever a call is received or transmitted on one of these systems, companding is automatically enabled. Companding is not selectable by the user, and the companding status is not indicated in the display. The control line for this function (Output A or B) also must be programmed for "Compend" and active high as described in Section 4.9.

### 3.5.5 DATA SYSTEM/GROUPS

Digital equipment such as a mobile data terminal or modem can be connected to this transceiver. An optional data interface cable (see Table 1-3) connects this equipment to J301 on the audio/logic board. Installation of this cable is described in Section 2.7.

When data equipment is used, the transceiver can be programmed so that data transmissions automatically occur on data system/groups. Each LTR and conventional group can be programmed for data transmissions. If the selected system/group is not programmed for data transmissions, the first selectable data group in the current system or the bank data system/group is selected. Likewise, if the PTT switch is pressed with a data system/group selected, the revert

or last selected voice group is selected. Refer to Appendix A.4 for more information on operation with a modem.

### 3.5.6 EMERGENCY SWITCH (HIGH TIER ONLY)

The Emergency option switch is available with high tier models only, and it is used to set up a high priority call. When the emergency switch is pressed, the emergency mode is indicated by "EMERGENCY" on the lower line of the display (this message can be disabled by programming if desired). The transceiver then looks at the emergency call information programmed in the currently selected system (or revert system if scanning). If there is no emergency information programmed for that system, it looks at the default emergency information programmed for that bank. It then switches to the specified emergency system/group.

No automatic transmissions occur with LTR transceivers. However, the chance that the system will be busy when a call is placed is minimized as much as possible. The transceiver locks onto the emergency system/group (other system/groups cannot be selected) and scanning is disabled. The only calls received are those occurring on the emergency system/group (calls are not received on the selectable, fixed priority, or block ID codes). To exit the emergency mode and resume normal transceiver operation, transceiver power must be cycled.

### 3.5.7 ENCRYPTION

Voice encryption is an optional feature that prevents conversations from being monitored by casual eavesdropping and analog scanners. This is accomplished by encrypting the voice signal so that it can be understood only by someone using a transceiver equipped with similar encryption device. To have this feature, a separate encryption module is installed in the Option Slot 1 on the audio/logic board. The control line for this function is programmed as described in Section 4.9.

Each LTR and conventional group can be individually programmed for encryption. Then when one of these groups is selected, encryption is automatically enabled or disabled. When encryption is enabled with high tier models,  is indicated in the display as

shown below. With low tier models, if one of the auxiliary switches is programmed for encryption (see next paragraph), the display decimal point associated with that switch is the encryption indicator.

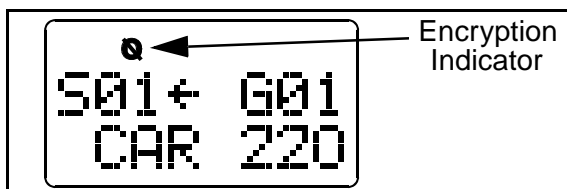

Encryption can also be manually enabled or disabled by the ENCRYPT menu parameter (high tier only) an option switch if it is programmed for encryption. This allows the user to override the group encryption programming. Selecting another system or group causes encryption to revert to the status PC programmed for that group.

Encrypted calls are received even if encryption is not enabled. However, encryption must be enabled to transmit an encrypted call. When transmitting an encrypted call, wait approximately 1 second before speaking. This gives the receiving encryption device time to establish synchronization which ensures that all of the first word is received. If the proceed tone is used (see Section 3.5.13), speaking can begin as soon as it sounds because it is delayed for the required time.

### 3.5.8 FUNCTION SWITCH (HIGH TIER ONLY)

The FCN (function) switch performs the following functions. If this switch is not programmed or is disabled, these functions are not available. When the function select mode is active, "FCN" is displayed on the lower line of the display. This mode is automatically exited if no additional activity occurs within 8 seconds.

**Menu Mode Select** - Pressing FCN twice selects the menu mode described in Section 3.6.

**Home System/Group Select** - Pressing FCN and then the Select switch selects the home system/group as described in Section 3.5.9.

**Squelch Adjust** - Pressing FCN and then rotating the Select switch sets the conventional mode squelch level as described in Section 3.4.6.

### 3.5.9 HOME SYSTEM/GROUP SELECT

The Home Select feature quickly selects the preprogrammed home system/group. With low tier models, this is done by pressing the AUX1 or AUX2 switch programmed for this feature. With the high tier models, the home system/group is selected by first pressing the FCN switch and then the Select switch. The home system/group is then displayed and it becomes the selected system/group (it is not temporarily selected).

If the home system/group is selected while scanning, scanning halts for the programmed scan delay period. With high tier models, if the home system is programmed but the group is left blank, the last selected group in that system is selected. If no home system is programmed or the FCN switch is disabled, the home select feature is not available. With low tier models, the home system/group must be one that is selectable, and both the system and group must be programmed.

### 3.5.10 HORN ALERT

#### General

This feature activates an external alert such as the vehicle's horn or lights when calls are received on selectable groups or priority ID codes programmed for this feature. With high tier models, when enabled either manually or automatically as described in the following information,  is displayed as shown in the following illustration. With low tier models, if an AUX1/AUX2 switch is programmed for horn alert, the decimal point for that switch is the horn alert indicator. If no horn switch is programmed, there is no indicator.

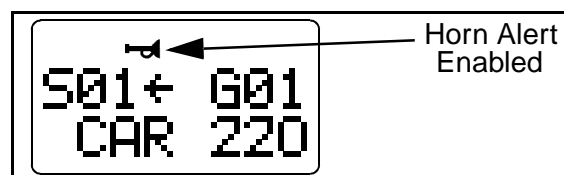

With low tier models, the horn alert on-off times and number of cycles is fixed. When a call is received that enables the horn alert, it turns on for 0.5 second and off for 0.5 second for three cycles (3 seconds). It then goes back to the disabled state. With high tier models, the on and off times are each programmable

for .25, .50, .75 or 1.0 second, and the cycles are programmable for 1-8. Horn alert installation is described in Section 2.4.

### Operation in Modes A and B

The horn alert is programmed to operate in Mode A or Mode B (descriptions follow). The on or off condition that is automatically selected by these modes can be changed using the HRN ALRT menu parameter (high tier models only) or an option switch programmed for the horn function (see Section 3.5.1). For example, when power is turned on in Mode B, the horn alert automatically turns off. It could then be enabled by pressing the option switch.

A “power-off delay” can be PC programmed to occur when power is turned off by the ignition switch (see Section 3.5.12). The horn alert can then remain active for a time after the ignition is turned off. If the ignition switch does not control transceiver power, only the front panel power switch affects operation in the following modes.

#### **Mode A (Manual On/Off)**

The current horn alert mode does not change when power is turned on or off by either the ignition switch or power switch. Therefore, the horn alert is totally controlled by the option switch or menu parameter.

#### **Mode B (Automatic On/Off)**

Ignition Switch - The horn alert always turns off when the ignition switch is turned on, and always turns on when the ignition switch is turned off (if there is a power-off delay programmed).

Power Switch - The horn alert is always off when the power switch is turned on.

*NOTE: The preceding automatic operation overrides an on or off condition that may have been selected by the menu mode or option switch.*

#### Permanently Enabling Horn Alert

If neither an option switch nor menu parameter is programmed, this feature can be permanently enabled

by programming the horn alert default to “ON”. Operation in each mode is then as follows:

**Mode A** - If the horn alert is to be always enabled, this mode could be used.

**Mode B** - This mode could be used if the ignition switch controls power. The horn alert is then always disabled when the ignition switch is on and always enabled during the turn-off delay when it is off. If the ignition switch does not control power, this mode cannot be used because the horn alert turns off the first time power is turned on and there is then no way to turn it back on.

*NOTE: A programmed default condition remains in effect only until the first time it is manually or automatically changed.*

### 3.5.11 OPTION SELECT

A programmable option switch (see Section 3.5.1) or the OPTION menu parameter (see Section 3.6.16) can be used to control some type of dealer-defined accessory such as a DTMF decoder. When the switch is used, the enabled condition is indicated by the decimal point for the switch (low tier models) or ▲ in the display (high tier models).

If this function is used, the I/O line controlling the option (such as the Output D line of accessory connector J101) must be programmed for the Accessory Option as described in Section 4.9. These are CMOS outputs with a 470-ohm series resistance and a typical maximum source and sink current of 2 mA. Therefore, some type of driver circuit may be required.

### 3.5.12 POWER TURN-OFF DELAY

The transceiver can be installed so that the vehicle ignition switch as well as the front-panel power switch controls transceiver power. This is done by installing the ignition switch cable and removing R170 on the audio/logic board (see Section 2.4.3). Turn-off delays of Immediate, 10, 20, 30, 40, or 50 minutes, 1, 2, 4, 8, 10, 12, or 16 hours or Forever can then be programmed. The delay can be overridden at any time by turning power off using the front-panel power switch or turning the ignition switch back on.

A turn-off delay allows features such as the horn alert and call indicator to remain active for the programmed delay time after the ignition switch is turned off. At the same time, advantages of ignition switch control can be utilized such as preventing battery discharge that may occur if the transceiver is accidentally left on for an extended period.

### 3.5.13 PROCEED (CLEAR-TO-TALK) TONE

This is a short tone that sounds shortly after the PTT switch is pressed to indicate that the system has been accessed and speaking can begin. It is always available on LTR systems and can be enabled and disabled on all conventional systems by programming. This and other tones can also be enabled or disabled by the Tones menu parameter (high tier only) or programming as described in Section 3.5.17. There is also a programmable option to select a standard or loud (two-pitch) tone.

If the radio system is busy when making an LTR call, the busy tone sounds instead of the proceed tone and “BUSY” is indicated on the bottom line of the display (high tier only, see Section 3.10). If the PTT switch is held down, the system is accessed and the proceed tone sounds when it is available. If an out-of-range condition occurs, the intercept tone sounds and “OUT-RNGE” is indicated in the display (high tier only). The PTT switch must then be released and pressed again to make another call attempt.

On conventional systems, no data handshake with a repeater occurs, so a busy or out-of-range condition cannot be detected from data. The Transmit Disable On Busy feature can be used to automatically perform monitoring (see Section 3.9.2). If the channel is then busy, the proceed tone does not sound unless the transmitter is keyed by quickly releasing and then pressing the PTT switch. Otherwise, the proceed tone sounds (if enabled) even if the channel is busy.

With all operating modes, if encryption is programmed, a 0.9-second delay occurs and two beeps sound instead of one. With conventional operation, if Call Guard squelch or an external decoder is programmed on the group, there is a 0.5-second delay before the proceed tone sounds. These delays give the receiving mobile time to detect the encryption or Call Guard signal which prevents the partial loss of the first word of the transmitted message.

### 3.5.14 PROGRAMMABLE POWER OUTPUT

With low tier models, one of two power output levels can be PC programmed for each LTR and conventional system. With high tier models, one of five levels can be programmed. The actual power output at each of these levels is set during transceiver alignment described in Section 7.3.4. For example, the high power level could be set for maximum rated power, low 1 for 20 watts, low 2 for 15 watts, and so on. Power output is not user selectable, and the currently selected level is not indicated.

### 3.5.15 STEALTH MODE (HIGH TIER ONLY)

The stealth mode disables the following tones and indicators so that they do not reveal that the transmitter has been keyed or the presence of someone using the transceiver. However, the receive (speaker) audio and display remain enabled in the stealth mode.

- All supervisory tones (see Section 3.5.17)
- The front panel tri-color indicator
- Display backlight

The stealth mode is available with high tier models only, and is selected by the Stealth option switch or menu STEALTH parameter (see Section 3.6.2). The above functions are disabled immediately when the switch is pressed, and there is no special indication that this mode is selected. With the menu mode, the tones and indicator are disabled immediately when “ON” is selected, and the backlight remains enabled until the menu mode is exited. If the stealth mode is not selectable by a switch or the menu, it is fixed in the on or off condition by programming.

### 3.5.16 TIME-OUT TIMER

#### General

The time-out timer disables the transmitter if it is keyed continuously for longer than the programmed time. It is programmed in half-minute increments from 0.5 - 5.0 minutes or it can be disabled. If the transmitter is keyed continuously for longer than the programmed time, the transmitter is disabled, “TIMEOUT” is indicated on the lower line of the display (high tier models only), and the conversation time-out tone sounds. The timer and tone are reset by releasing the PTT switch. Ten seconds before time-out

occurs, the return time warning tone sounds to indicate that time-out is approaching.

One use of this feature is to prevent a repeater from being kept busy for an extended period by an accidentally keyed transmitter. It can also prevent possible damage to the transmitter caused by transmitting for an excessively long period.

### Penalty Timer

There is also a penalty timer that can be programmed. If the time-out timer disables the transmitter, this timer prevents the transmitter from being keyed again for the programmed time. This prevents a user from simply releasing the PTT switch and pressing it again to continue a call. This timer can be programmed for 0-60 seconds in 1-second steps. It is available with all models, and starts when the PTT switch is released. If the PTT switch is pressed during the penalty time, the time-out indication occurs again.

### 3.5.17 TONE SELECT

If the TONES menu parameter is enabled by programming (high tier models only), the user can select the tones that sound. Otherwise, the tone mode is selected by programming. The following choices are available:

**SILENT** - All tones are disabled.

**KEY BEEP** - Only the Select switch (low tier models only) and key press tones are enabled.

**ALERT** - All tones except the preceding Key Beep tones are enabled.

**ALL TONE** - Both the preceding Key Beep and Alert tones are enabled.

### 3.5.18 TRANSMITTER THERMAL FOLDBACK

The temperature of the power amplifier is monitored by the control logic when transmitting. If a temperature is detected that could damage the power amplifier module or other devices, power is automatically cut back to a preset low level. After sufficient cooling occurs, power output returns to the normal level. This provides hysteresis so that power is not cut back again after only a short transmission. With the low tier models, there is no indication that power is cut back. With high tier models, the transmit LED is orange instead of red (no message is displayed).

If temperature continues to increase at the low power setting to the point where more serious damage could occur (this should seldom happen), the transmitter is disabled, a warning tone sounds, and “NO POWER” is displayed (high tier models only). The transmitter remains disabled until temperature decreases to the first temperature limit. Power output is then produced at the preset low setting. The temperature limits and low power level are fixed in software.

The supply voltage applied the transceiver is also monitored in the transmit mode. If this voltage rises above 18.5 volts DC, the transmitter is disabled and the same indications are produced as described in the preceding paragraph. This prevents possible damage to transistors in the transmitter.

## 3.6 OPTION SWITCHES AND MENU MODE

### 3.6.1 USING OPTION SWITCHES

The option switch availability for the various models is as follows. If a function is controlled by an option switch, it is not available as a menu function and vice versa (high tier models only). Any switch can also be disabled if desired. Descriptions of switch functions start with Section 3.6.9.

Low Tier Models - Four option switches are available (see Figure 3-1). The top two have fixed functions (SCAN and A/D) and the bottom two (AUX1 and AUX2) are programmable for the functions listed in Table 3-2.

High Tier Models - Five option switches are available (see Figure 3-2) and all are programmable for any of the functions listed in Table 3-2. A key cap kit is supplied with the transceiver that contains key caps with labels for all available functions.

### 3.6.2 USING MENU MODE

*NOTE: The menu mode is not available with low tier models. Therefore, menu functions are either fixed in a default condition by programming or not available.*

The menu mode is selected by pressing the FCN option switch twice within 8 seconds. If this switch has been disabled or is not programmed, the menu mode is not available. The functions that can be controlled by the menu mode are indicated in the “Menu Items”

Table 3-2 Menu Mode and Option Switch Functions

Function	Menu Items (High Tier Only)	Option Switch	
		Low Tier	High Tier
Add/delete (scan list prg)	-	Fixed	A/D
Backlight adjust	BACKLGH	-	-
Bank select	BANK SEL	-	-
Call Guard sq. disable	-		CG
Emergency	-	-	EMER
Encryption on-off	ENCRYPT	AUX1/AUX2	ENCPT
Function select	-	-	FCN
Home sys/grp select	-	AUX1/AUX2	FCN then press Sel Sw
Horn Alert on-off	HRN ALRT	AUX1/AUX2	HORN
LTR system search	SYS SRCH	-	-
Menu mode select	-	-	FCN (twice)
Monitor mode select	-	AUX1/AUX2	MON
Option select	OPTION	AUX1/AUX2	AUX
Priority sampling on-off	PRIORITY	AUX1/AUX2	PRI
Scan on-off	-	Fixed	SCAN
Scan type select	SCN TYPE	-	-
Scan continue on-off	SCN CONT	-	-
Scan list save mode	SCN SAVE	-	-
Stealth mode select	STEALTH (high tier only)	-	STLH
Squelch adjust	-	AUX1/AUX2	FCN then rotate Sel Sw
System/group display mode select	S/G DISPL (high tier only)	-	-
Talk-around on-off	TALKARND	AUX1/AUX2	TA
Tone type select	TONES	-	-
<i>NOTE: Parameters left blank are not available.</i>			

column of Table 3-2. Some functions can also be controlled by programmable option switches (see preceding section). Other highlights of menu mode operation are as follows. Individual descriptions of menu mode functions start with Section 3.6.5.

- Programming determines what functions are displayed in the menu mode. If a function is controlled by a menu parameter, it cannot be controlled by the option switch and vice versa.
- Some functions can be set in a fixed condition by disabling the option switch and menu item and then programming the default condition in the menu for the desired mode. However, if a parameter can be changed by an option switch or menu parameter or is automatically changed (such as the horn alert described in Section 3.5.10), the programmed default condition is maintained only until the first time it is changed.
- Calls cannot be received or transmitted while in the menu mode.
- Pressing any control other than the select switch while in the menu mode produces an error tone.

### 3.6.3 USING MENU MODE

To use the menu mode, proceed as follows:

1. Press the FCN option switch twice within 8 seconds to select the menu mode. The top line indicates the function being edited, and the bottom line indicates the current status as follows.
2. To display the various functions that are controllable by the menu mode (top line indication), rotate the Select switch. The currently selected status is displayed for each function.

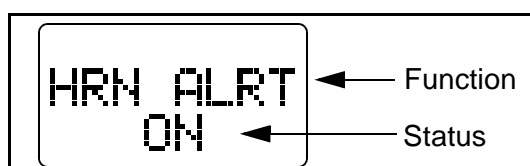

**Menu Mode Display**

3. To change the selected status, press the Select switch. Information displayed for each menu parameter is shown in Section 3.10.4.
4. To display another menu function, rotate the Select switch. Then change the status if desired as described in the preceding step.
5. The selected configurations for the various functions are saved when the menu mode is exited in one of the following ways:
  - Pressing the FCN option switch again
  - Pressing the PTT switch
  - Automatically when time-out occurs 2 seconds after a change is made or 8 seconds after no changes are made.

### 3.6.4 A/D (SCAN LIST PROGRAMMING)

The A/D option switch is used to add and delete systems or groups from the scan list. Pressing this switch changes the status of the displayed system or group. Refer to Section 3.7.2 for more information.

### 3.6.5 BACKLIGHT ADJUST

The menu BACKLGHHT parameter can be used to set the backlight for Bright, Dim, or Off as described

in Section 3.4.3. If this feature is not controlled by the menu mode, the default condition is usually programmed Bright or Dim so that it is always in that state when transceiver power is on.

### 3.6.6 BANK SELECT

With high tier models only, if two or more banks or systems are programmed, the BANK SEL menu parameter can be used to select banks. Refer to Section 3.5.2 for more information.

### 3.6.7 CALL GUARD SQUELCH DISABLE

The CG option switch disables both receive and transmit Call Guard squelch on the selected system/group. Refer to Section 3.9.5 for more information.

### 3.6.8 EMERGENCY SWITCH

Pressing the EMER switch sets up a high priority call as described in Section 3.5.6.

### 3.6.9 ENCRYPTION ON-OFF

The ENCRYPTION menu parameter or an option switch programmed for encryption allows the user to override the encryption mode that has been programmed on the selected group. When the menu mode is used, the enabled condition is indicated by "ON" and the disabled mode by "OFF". When encryption is enabled,  is indicated in the display (high tier only). Refer to Section 3.5.7 for more information.

### 3.6.10 FUNCTION SELECT (HIGH TIER MODELS)

The FCN (function) switch of high tier models performs the following functions. If this switch is not programmed or is disabled, these functions are not available. Refer to Section 3.5.8 for more information.

Menu Mode Select - FCN/FCN

Home Sys/Grp Select - FCN/press Select switch

Squelch Level Adjust - FCN/rotate Select switch

### 3.6.11 HOME SYSTEM/GROUP SELECT

With high tier models, the home system/group is selected by pressing FCN and then the Select switch.

With low tier models, it is selected by pressing the AUX1 or AUX2 switch programmed for that function. Refer to Section 3.5.9 for more information.

### 3.6.12 HORN ALERT

When an external alert such as the vehicle's horn or lights is used to signal an incoming call, the menu HRN ALRT parameter or an option switch programmed for horn alert can be used to turn this feature on and off. Refer to Section 3.5.10 for more information.

### 3.6.13 LTR SYSTEM SEARCH SELECT

The menu SYS SRCH parameter allows the LTR system search feature to be turned on and off by the user. When it is on, the transceiver automatically searches for another system when an out-of-range condition occurs when making an LTR telephone call. Refer to Sections 3.8.5 and 3.8.8 for more information.

### 3.6.14 MENU MODE SELECT

The menu mode is selected by pressing the FCN switch twice within 8 seconds. Refer to Section 3.6.2 for more information.

### 3.6.15 MONITOR MODE SELECT

When a conventional system is selected, an option switch programmed for the monitor function selects the monitor mode described in Section 3.9.1. This mode disables Call Guard squelch or other squelch control features so that all messages occurring on a channel are heard. The monitor mode is indicated by  in the display (high tier only).

### 3.6.16 OPTION SELECT

The OPTION menu parameter or an option switch programmed for option select can be used to control some type of dealer-defined accessory. When the menu parameter is used, "ON" selects the enabled condition and "OFF" selects the disabled condition ( is not displayed). Refer to Section 3.5.11 for more information.

### 3.6.17 PRIORITY SAMPLING SELECT

The PRIORITY menu parameter or an option switch programmed for that function enables or disables priority group sampling on conventional systems. Refer to Section 3.9.6 for more information.

### 3.6.18 SCAN ON-OFF

The SCAN option switch enables and disables scanning. With high tier models, the type of scanning is selected by the SCN TYPE menu parameter or programming. Refer to Section 3.7 for more information.

### 3.6.19 SCAN TYPE SELECT

The SCN TYPE menu parameter selects the type of scanning that occurs when it is enabled by the SCAN option switch. The following types are available. Refer to Section 3.7 for more information.

**SYS-GRP** - Both system and group

**GRP ONLY** - Group scanning only

**OFF** - Both system and group scanning off

### 3.6.20 SCAN CONTINUE SELECT

A scan continue timer can be programmed which limits the amount of time spent monitoring a message. The menu SCN CONT parameter can be used to turn this feature on and off. When "ON" is selected, this timer is enabled, and when "OFF" is selected, entire messages are always received. Refer to Section 3.7.3 for more information.

### 3.6.21 SCAN LIST SAVE MODE

The SCN SAVE menu parameter determines if changes made to the system and group scan lists are saved as they are made. Changes are saved when "ON" is selected, and they are not saved when "OFF" is selected. See Section 3.7.2 for more information.

### 3.6.22 STEALTH MODE SELECT

The Stealth option switch or menu STEALTH parameter enables or disables the stealth mode available with high tier models only. This mode disables



the tones, tri-color indicator, and backlight. Refer to Section 3.5.15 for more information.

### 3.6.23 SQUELCH ADJUST

Refer to Section 3.4.6 for information on setting the conventional mode squelch level.

### 3.6.24 SYSTEM/GROUP DISPLAY MODE

With high tier models only, the S/G DISPL menu parameter selects either the numeric or alpha tag display mode. Refer to Section 3.4.4 for more information.

### 3.6.25 TALK-AROUND SELECT

The talk-around menu parameter (high tier models only) or an option switch programmed for that feature can be used to turn the conventional mode talk-around feature on and off. Refer to Section 3.9.4 for more information.

### 3.6.26 TONE TYPE SELECT

The TONES menu parameter selects the types of tones that sound when switches are pressed or busy or out-of-range conditions occur. The following tones can be selected. Refer to Section 3.5.17 for more information.

**SILENT** - All tones are disabled.

**KEY BEEP** - Only the Select switch and key press tones are enabled.

**ALERT** - All tones except the preceding Key Beep tones are enabled.

**ALL TONE** - Both the preceding Key Beep and Alert tones are enabled.

## 3.7 SYSTEM AND GROUP SCAN

### 3.7.1 GENERAL

#### Low Tier Scan Modes

Only the programmed system/group combinations selected by each display number are scanned if they are in the scan list (see Section 3.7.2). Separate system and group scan functions are not available.

System/group scanning is turned on and off by the Scan option switch. When system/group scanning is enabled, the green scan indicator is lighted, and when scanning is actually occurring, the “+” indicator is lighted (see following illustration).

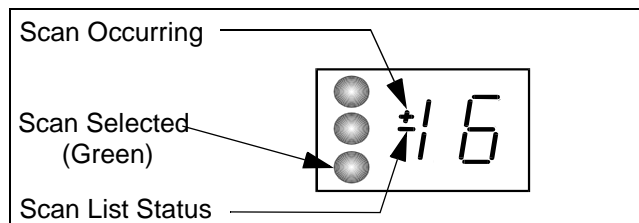

**Low Tier Scan Indicators**

#### High Tier Scan Modes

**System Scan** - The system scan feature detects calls on all selectable systems if they are in the system scan list. When system scan is not used, calls are detected on only the currently selected system.

**Group Scan** - The group scan feature detects calls on the selectable groups in the current or scanned systems that are in the group scan list. When group scanning is not used, calls are detected on only the currently selected group (or on the last selected group of each system if system scanning).

System and/or group scanning are turned on and off by the Scan option switch. When system and/or group scanning is enabled, **Z** is displayed, and when system or group scanning is actually occurring, a scrolling underline is displayed on the upper line (see following illustration).

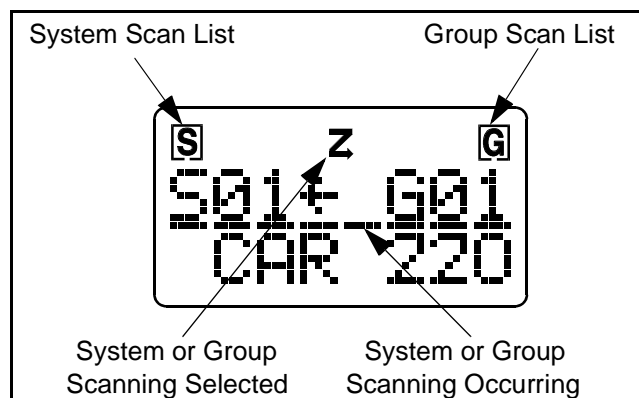

**High Tier Scan Indicators**

### Other Scan Information

With all models, calls on the priority and block ID codes are detected regardless of group scan programming. All that is required is that the system with those codes be selected or scanned.

The microphone must be on-hook for scanning to occur (unless off-hook detection has been disabled by programming). Scanning is sequential through the programmed systems and groups that are in the scan list (see Section 3.7.2). With the low tier models, scanning is in system order, not display number order.

When a message is detected that the transceiver is programmed to receive, scanning stops and the message is received. Shortly after the message is complete, scanning resumes (unless it has been disabled). The length of this delay is set as described in Section 3.7.3. The selected system and group (if applicable) can be changed while scanning in the normal manner. Scanning resumes shortly after the change is made.

When scanning is occurring (see preceding illustrations), transmissions always occur on the displayed system/group. However, when a message is received, scanning temporarily stops and the display changes to the system/group of the call (see Section 3.8.3 for a possible exception). A response may then occur on the displayed or selected group, depending on the programming described in Section 3.7.4

### Scan Types

The type of scanning is determined by the menu SCN TYPE parameter (high tier only) or default programming. The available types are as follows:

#### Low Tier Models

**SYS-GRP** - System/group scanning enabled  
**OFF** - System/group scanning disabled, SCAN switch non-functional

#### High Tier Models

**SYS-GRP** - Both system and group enabled  
**GRP ONLY** - Group scanning only enabled  
**OFF** - Both system and group scanning disabled, SCAN switch non-functional

With low tier models, if the Scan option switch is disabled, scanning is fixed in the programmed default condition. With high tier models, the following configurations can also be programmed:

- If the Scan switch is disabled, the SCN TYPE menu parameter can be used to select one of the preceding three modes.
- If both the Scan switch and menu parameter are disabled, scanning is fixed in the programmed default condition.
- If the SCN TYPE menu parameter is disabled, the user can enable only the type of scanning selected by programming.

With high tier models, group scanning can be disabled on systems by programming Group Scan = "No". It then does not occur on those systems even if it is enabled as described. Calls are then received on only the last selected group of those systems.

### 3.7.2 SCAN LIST PROGRAMMING

*NOTE: Calls are always detected on the revert (selected) system/group while scanning, even if it is deleted from the scan list.*

The scan list can be programmed without selecting the scan mode. Operation with the different models is as follows:

#### Low Tier Models

Only the selectable groups can be added to or deleted from the scan list. To change the status of the displayed system/group combination, press the A/D option switch. The displayed system/group is *not* in the scan list (not scanned) when "-" is displayed (see preceding illustration). If the A/D switch has been disabled by programming, scan list programming is not available.

The status of individual systems cannot be changed. For example, if two or more groups of the same system can be selected, only the group that is displayed is deleted. Assume "1" selects System 1/Group 1 and "2" selects System 1/Group 2. Deleting the "1" system/group does not delete the "2" group even though it belongs to the same system.

## High Tier Models

The system and group scan lists are user programmable using the A/D (add/delete) option switch. If this switch is not programmed or disabled, scan list programming is not available. The displayed system is in the scan list and scanned normally when **S** is displayed. Likewise, the displayed group is in the scan list and scanned normally when **G** is displayed (see illustration in Section 3.7.1).

The system/group select mode described in Section 3.4.5 also controls if the system or group scan list is changed when the A/D switch is pressed. If the switch is pressed with the system select mode enabled, the status of the displayed system is changed. Then if it is pressed with the group select mode enabled, the status of the group is changed. For example, to change the status of the displayed system, press the Select switch if necessary so that the system select mode is indicated and then press the A/D switch.

As described in the preceding section, group scan list programming is disabled if group scanning is disabled on the current system. If an attempt is made to program the group scan list on one of these systems, the error tone sounds, "GSCN DIS" is flashed in the display, and no change in the scan list occurs.

Deleting a system only temporarily deletes the groups associated with that system. When a system is added back into the scan list, the original group scan list is again active. Systems and groups can be deleted from the scan list while listening to a message on the system or group by pressing the A/D switch in the normal manner. Scanning resumes shortly after the system or group is deleted.

### Saving Current Scan List Changes

The menu SCN SAVE parameter (high tier only) or programming determines if changes to the system and group scan list are saved. If "ON" is selected, changes are saved to permanent memory as they are made and the scan list does not change when power is cycled. If "OFF" is selected, changes are not saved to permanent memory.

Therefore, with low tier models, if the default scan list save mode is programmed "ON", changes are

saved and the scan list returns to the same state when power is turned back on. Conversely, if "OFF" is programmed, they are not saved and it reverts to the programmed default status.

With high tier models, if the SCN SAVE menu parameter is selectable and "ON" is selected, changes are saved until "OFF" is selected. Further changes are then not saved. Therefore, to store a list, select "ON", program the list, then select "OFF". Then when power is cycled, the scan list returns to the state that existed when "OFF" was selected.

### 3.7.3 SCAN DELAY AND CONTINUE TIMERS

*NOTE: The following timers are also used in some circumstances when not scanning, such as when LTR priority or block ID calls are received as described in Section 3.8.3.*

#### Receive Delay

When a message is received while scanning, there is a programmable delay of 0-7 seconds before scanning resumes. This delay is called the Receive Delay Time, and it prevents another message from being received before a response can be made. This delay is also in effect if a control is changed while scanning such as selecting another system/group. This timer is reset each time another call is received.

*NOTE: Scanning does not resume if it is disabled, such as by taking the microphone off-hook.*

#### Call Delay Time

The receive delay time controls the scan delay until the transmitter is keyed and then the Call Delay Time controls the delay. This time is programmable for 0-7 seconds, and it ensures that a response to your message is heard instead of some other message occurring on another system/group. The Call Delay Timer remains active for the remainder of the conversation, and controls when normal scanning resumes, even if additional responses are received.

#### Scan Continue Timer

There is also a scan continue timer that can be programmed. This timer controls the maximum time

that a call is received before scanning resumes. This prevents scanning from being delayed for long periods by lengthy calls. This time can be programmed for 0-60 seconds in 1-second steps. If “0” is programmed, there is no time limit and the entire message is always received. If the menu SCN CONT parameter is available, this feature can be turned on and off by the user (see Section 3.6.20).

### 3.7.4 TRANSMITTING IN THE SCAN MODE

When the transmitter is keyed in the scan mode, programming of the “Scan Revert Mode” radio parameter determines if the transmission occurs on the last selected, last received, or a fixed system/group. In addition, if the selected system/group changes, this programming also affects which system/group is selected when the scan mode is exited by pressing the SCAN switch.

If the fixed transmit system/group bank parameter is programmed, it may override the following programming. Refer to Section 3.7.5 for more information. The display usually indicates the system/group on which a transmission would occur. The exceptions may be when receiving a call with “last selected” programmed and when using the fixed transmit function just mentioned.

The three programmable Scan Revert Mode configurations are as follows. When an LTR priority call is received (see Section 3.8.3), this programming also determines if a transmission occurs on the displayed or selected group, even if scanning is disabled.

**Last Selected System/Group** - Transmissions always occur on the last system/group that was selected manually by the CHL (low tier) or Select (high tier) switch. To respond to a call not on the selected system/group, one of the following methods can be used:

- Select the system/group of the call manually using the Select switch.
- Before scanning resumes, exit the scan mode by pressing the SCAN switch. The system/group of the call then becomes the selected system/group and it is not necessary to change it manually.

**Last Received** - The selected system/group changes to the system/group of a call. Therefore, you can always respond to a call without having to manually change the system/group. To return to the previously selected system/group, the CHL or Select switch must be used to manually select it.

**Temporary Last Received** - The display changes to the system/group of a call for only the duration of the scan delay period described in Section 3.7.3. Then when the delay expires and scanning resumes (if not disabled, for example, by taking the microphone off-hook), the selected system/group is again displayed. Therefore, you can respond to a call without changing the selected system/group as long as you do so before scanning resumes.

### 3.7.5 FIXED TRANSMIT IN SCAN

If a system and group are entered for the “Fixed System/Group Transmit During Scan” bank parameter, this programming may take precedence over the programming just described. If this is programmed and the transmitter is keyed while scanning is occurring (“+” or scrolling underline displayed), transmissions always occur on that system/group. In addition, it becomes the selected system/group.

Since taking the microphone off-hook normally disables scanning (unless off-hook detection is disabled), the microphone must usually be on-hook when the transmitter is keyed. If the transmitter is keyed with scanning halted or if no system/group is programmed for this function, the programming described in the preceding section takes precedence.

### 3.7.6 SCANNING LTR SYSTEMS

LTR systems are monitored each scan cycle for only as long as necessary to detect all calls. If fixed priority or block ID codes are programmed, calls on those codes are detected regardless of which group is selected or group scan programming. All that is required is the system programmed for those codes must be selected or scanned.

With low tier models, the programmed system/groups are scanned in system sequence. Scanning is in display number sequence only if system/groups were assigned in order. If several positions are programmed

with the same system number, system information is loaded only once. Therefore, there is no delay with to change systems which results in very efficient scanning of those positions. The group select and group scan functions are not available with this transceiver.

### 3.7.7 SCANNING CONVENTIONAL SYSTEMS

As described in Section 3.4.7, conventional systems select blocks of up to sixteen channels, and groups select a channel within that block. With the low tier models, each display number programmed for conventional operation selects a specific radio channel, and channels are scanned in system sequence (see preceding section). With high tier models, group scanning determines whether calls are received on all channels (groups) or only the last selected channel of selected or scanned systems.

With all models, Call Guard squelch is detected if the monitor mode is disabled (see Section 3.9.1). If the monitor mode is enabled, all calls occurring on a channel (group) are received. Priority group sampling is also available with scanning. Refer to Section 3.9.6 for more information.

A feature called Adaptive Tone Scan (ATS) is used when scanning conventional channels. If no carrier is detected, the channel is scanned for only 40 ms. If a carrier is detected, searching for Call Guard signaling occurs (if programmed). If the tone type of Call Guard squelch is programmed, the channel is monitored for 180-420 ms. The shorter time is when the tone is outside certain limits, and the longer time is if it is at or near the programmed value. If digital type is programmed, approximately 350 ms is required to determine an invalid code (less time is usually required to detect valid codes).

## 3.8 LTR FEATURES

### 3.8.1 SYSTEMS

When a system is programmed for LTR operation, information such as repeater channel numbers, home repeater, and all encode and decode ID codes are specified. The ID codes can be fixed, selectable, and block types. The types of ID codes and the number that can be programmed in each category are shown in the following table. Any combination of codes can be programmed and all codes can be different.

Decode (Receive)	Encode (Transmit)
Fixed	
2	N/A
Selectable	
1 (low tier)	1 (low tier)
16 (high tier)	16 (high tier)
Block	
Up to all 250	N/A

### 3.8.2 GROUPS

*NOTE: Receive-only LTR groups are programmed by an encode ID of "0".*

The group select function chooses the selectable encode and decode ID codes (high tier only). Only the selected encode ID code is sent when transmitting (it is not possible to place a call to more than one code). Calls are received on the selected ID code plus any fixed priority and block decode codes. The group scan feature (high tier only) determines if calls are received on all or only the selected ID code of a selected or scanned system.

As previously stated, low tier models can be programmed with up to sixteen system/group combinations. In addition, the group select (and therefore group scan) features are not available. Refer to Section 3.7 for more information.

### 3.8.3 RECEIVE PRIORITY ID CODES

#### General

With standard (dispatch) calls, the fixed, selectable, and block ID codes have a priority order so that an incoming call with a higher priority ID code can interrupt a lower priority call in progress. Conventional systems can have another type of priority which is described in Section 3.9.6.

One use of receive priority is to allow someone such as a dispatcher to interrupt calls in progress with an important "all call" message. If the transceiver detects a call with a higher priority ID than the one it is receiving, it immediately drops the current call and switches to another repeater to receive the higher priority call. Telephone calls are not interrupted by

priority calls. The priority order of the decode ID codes is as follows:

1. Fixed Priority ID Code 1
2. Fixed Priority ID Code 2
3. Selectable ID Codes
4. Block ID codes

For example, if a call is being received on selectable group 4 and a call is detected on fixed priority ID 2, the call on group 4 is immediately dropped and the transceiver switches to the call on fixed priority ID 2. With high tier models only, when a call is detected on fixed priority ID code 1, "PRIORTY1" is indicated on the bottom line of the display. Likewise, when a call is received on priority ID 2, "PRIORTY2" is displayed.

The selectable ID codes are checked to see if any are the same. If a match is found, the transceiver changes to that group. If no match is found, it does not change and a response cannot be made using that ID code. When a call is received on a block ID code, "BLK CALL" is displayed on the bottom line but the display does not change.

If a change to a selectable group occurs, the scan revert mode programming described in Section 3.7.4 determines if the change to the new group is temporary or permanent and if a transmission occurs on the new group. In addition, if the change is not permanent, the programming of the scan delay described in Section 3.7.3 determines how long the transceiver stays on the priority group.

With LTR operation, incoming call information is received on only the home repeater. Therefore, priority calls are not detected while trunked to some other repeater. To reach most mobiles with a priority message in this case, the operator can key the transmitter and then not begin speaking for several seconds. This allows trunked-out mobiles time to finish the transmission and return to the home repeater.

This still may not reach mobiles making telephone calls because they hold a repeater for the duration of a conversation (instead of the duration of the transmission as with dispatch calls). Other times when priority calls could be missed are when some other system not programmed with the priority ID is being monitored and while transmitting.

### Transmit Disable On Block IDs

Each bank can now be programmed so that transmitting is inhibited while a call is being received on a block ID code. This operation is selected on the Create/Edit Bank screen by programming "Inhibit Transmit During Block Decode = Yes". The transmitter can be keyed immediately after the call is complete (there is no 5-second delay as with the transmit inhibit feature). When this parameter is programmed "No", the transmitter can be keyed while receiving a call on a block ID. This feature is available with operating (Flash) software Version 211 or later, and programming software version 210 or later.

### 3.8.4 LTR STANDARD CALLS

LTR standard calls are between mobiles or groups of mobiles using the standard group ID codes from 1-250 that are assignable to each LTR home repeater. A standard call is placed by simply selecting a group programmed with the ID code of the mobile being called. No number is dialed as with telephone calls. To receive a standard call, the mobile must be programmed to decode the ID code being transmitted. Refer to Section 3.4.8 for more information on placing and receiving standard calls.

### 3.8.5 LTR TELEPHONE CALLS

#### General

To place and receive LTR telephone calls, the transceiver must be programmed with a block of telephone ID codes. This block of codes may include from one ID code up to all 250 ID codes assignable on a home repeater. When an ID code within this block is decoded (received) or selected to be encoded (transmitted), the transceiver enters the telephone operating mode. An optional DTMF microphone is required to dial the telephone number.

Operation is half-duplex which means that the PTT switch must be pressed to talk and released to listen (the same time as with a dispatch call). Therefore, the mobile user cannot hear the landside caller while transmitting or speak to the landside caller while receiving.

### Placing an LTR Telephone Call

1. Turn transceiver power on and set the volume as described in Sections 3.4.1 and 3.4.2.
2. Select the system and group programmed for telephone calls. With high tier models, when a group programmed for telephone calls is selected, the telephone symbol  is displayed.
3. Briefly press the PTT switch to obtain a dial tone. A successful access and busy or out-of-range conditions are indicated as described in Section 3.4.8. The following are additional features available when making telephone calls:

*NOTE: The display messages and menu parameters mentioned in the following information are not available with low tier models.*

**Busy** - If the system is busy (busy tone sounding) and the Busy Queuing feature is PC programmed on the selected system, it is automatically selected when the PTT switch is released. The display indicates "IN QUEUE" when this mode is selected. Refer to Section 3.8.7 for more information.

**Out-of-Range** - If an out-of-range condition exists, it is indicated by an intercept tone and "OUT-RNGE" in the display. If the System Search feature has been enabled by the menu SYS SRCH parameter or programming, it is automatically selected when the PTT switch is released. The display indicates "SYS SRCH" when this mode is selected. Refer to Section 3.8.8 for more information.

4. When a dial tone is heard, enter the number to be called in one of the following ways:
  - Enter it directly using the 0-9 keys. If too much time elapses between digits, the call is terminated.
  - If the microphone has a memory, it may be possible to recall the number from memory and dial it automatically.
5. After the number is sent, landside ringing should be heard (a landside busy condition could also be indicated). When the other party answers, press the PTT switch and respond. The PTT switch must be

pressed to talk and released to listen, the same as with a standard calls.

6. When the call is finished, press the # key to terminate the call. Three beeps indicate that the call has been terminated. Terminating the call in this manner prevents extra billing that may occur for the time required for the system to automatically detect the end of the call.

### Receiving a Telephone Call

1. Turn transceiver power on and set the volume as described in Sections 3.4.1 and 3.4.2.
2. Select or scan the system and group programmed for telephone calls. When a group programmed for telephone calls is selected, the telephone symbol  is displayed (high tier only).
3. When "ringing" is heard, press the PTT switch and respond. The PTT switch must be pressed to talk and released to listen as with a dispatch call.
4. When the call is finished, it should be terminated as in step 6 of the preceding section.

### Placing a Landside-To-Mobile Telephone Call

Calls can be placed from a landside telephone to a mobile transceiver (if the transceiver and radio system have this capability). With most systems, a mobile user can be called directly (each has a unique telephone number). With others, the mobile being called must be specified as follows:

1. Dial the number of the radio system in which the mobile transceiver is operating.
2. When the system answers, a short tone sounds to indicate that the number of the mobile being called should be dialed. This number is five digits long and must be dialed using a tone-type telephone. The first two digits are the home repeater number of the mobile, and the last three digits are a telephone group ID code of that mobile. With LTR interconnect equipment, the first digit must be dialed within 5 seconds of hearing the tone, and no more than 5 seconds must elapse between digits or the call is terminated.

3. Ringing is then heard by the landside caller while the mobile is being rung.

### 3.8.6 TRANSMIT INHIBIT

This feature prevents the transmitter from keying if the mobile being called is busy with another call. To enable this feature, the LTR system is PC programmed with a block of transmit inhibit ID codes that can include up to all 250. If a code within this block is detected up to 5 seconds before the PTT switch is pressed, the transmitter does not key, the intercept tone sounds, and “TX INHIB” is displayed.

To make another call attempt, the PTT switch must be released and then pressed again. Although the 5-second timer does count down while the PTT switch is pressed, it is not possible to complete the call by holding the PTT switch down until the intercept tone stops sounding.

One use of this feature is to prevent the accidental interruption of a call in progress. This could happen when the other transmitting party unkeys or if an ID code with a higher priority is transmitted. Another use of this feature is to provide an indication that the mobile being called is busy. A similar Transmit Disable On Busy feature is available on conventional systems.

### 3.8.7 BUSY QUEUING

*NOTE: This feature replaces Free System Ringback used in some earlier LTR transceivers.*

The busy queuing feature places a telephone call in a queue if the radio system is busy when it is placed. Then when the system becomes available, it is automatically accessed. Dispatch (mobile-to-mobile) calls are not queued by this feature. Busy queuing is enabled or disabled on each LTR system by PC programming. It is not selectable by the user.

If queuing is programmed and a busy condition is encountered, the queue mode is entered automatically when the PTT switch is released. The queue mode is indicated by “IN QUEUE” on the bottom line of the display (high tier models). Then when the radio system becomes available, the transceiver waits a random time and attempts to access the repeater. This

random delay minimizes the chance of collisions with other transceivers in queue.

If an access attempt is unsuccessful, another attempt is made after another random delay. This continues until an attempt is successful. A beep then sounds and the dial tone is heard. The number can then be dialed if desired. If a number is not dialed soon after the dial tone sounds, the call is automatically terminated.

The queue mode is exited before placing the call if any of the following occur (with high tier models, “IN QUEUE” is no longer displayed when exit occurs).

- The PTT switch is pressed
- Any call is received
- Any option switch is pressed
- Power is turned off

Calls are received normally in the queue mode; however, the queue mode is exited as indicated above. Group scanning remains enabled while in the queue mode, but system scanning is temporarily disabled.

### 3.8.8 SYSTEM SEARCH

If an out-of-range condition exists when attempting an LTR telephone call, this feature automatically searches for a system within range. With the high tier models, the system search feature can be enabled and disabled by the user if the menu SYS SRCH parameter is selectable (see Section 3.6.13). Otherwise, it is enabled or disabled on all LTR systems by programming.

The system search mode is automatically entered when the PTT switch is released. The bottom line of the display indicates “SYS SRCH” (high tier only) and a tone sounds when this mode is selected. The transceiver then attempts to access, in succession, other systems that have any group programmed for telephone calls. As each system is searched, a beep sounds. Each system is accessed only once.

If no system could be accessed, the intercept tone sounds, “NO PHONE” is displayed (high tier only), the system/group does not change, and the feature deactivates. If a system is accessed, the new system/



group is selected and a dial tone sounds. The number must then be sent by the user within a few seconds or normal operation resumes. This mode can be canceled at any time by pressing any option switch.

### 3.8.9 TRANSPOND

The transpond feature indicates if the mobile being called is in service. Transponding is enabled by programming it in the transceiver being called. Each selectable group of an LTR system can be programmed for transpond. Then if a call is received on one of these groups, the transceiver automatically transmits two data messages with the second containing the turn-off code. This causes the transceiver placing the call to briefly unscquelch and the call indicator to turn on (if it is programmed on the selected group). This feature is not available on fixed priority and block ID codes.

## 3.9 CONVENTIONAL MODE FEATURES

*NOTE: For more information on conventional operation, refer to Section 3.4.7.*

### 3.9.1 MONITOR MODE

The monitor mode allows all activity on a channel to be monitored when Call Guard squelch or other types of squelch control are used (such as external DTMF or two-tone decoders). The monitor mode disables these features so that all messages on the channel are heard. To select the monitor mode, take the microphone off-hook or press the MON option switch (see Section 3.6.15). The monitor mode is indicated by  in the display (high tier only).

If microphone off-hook detection has been disabled by programming, the MON switch must always be used to select the monitor mode or the Transmit Disable On Busy feature must be programmed (see next section). Scanning halts when the microphone is off-hook (unless off-hook detection is disabled). However, the monitor switch is not detected when scanning, so the microphone must always be used to select monitoring while scanning.

A conventional system must be selected to enable monitoring. If the MON switch is pressed with an LTR

system selected, NOT CONV is displayed (high tier only) and monitoring is not selected. If the microphone is taken off-hook with an LTR system selected, scanning halts (unless off-hook detection is disabled) but monitoring is not selected.

With high tier models, Call Guard squelch also can be disabled on the selected system/group by the CG switch (see Section 3.9.5). This switch disables both receive and transmit squelch control, while the monitor mode disables only receive squelch control.

### 3.9.2 TRANSMIT DISABLE ON BUSY

The Transmit Disable On Busy feature automatically disables the transmitter if the channel is busy (carrier present) when the PTT switch is pressed. It is enabled or disabled on each conventional group by programming. If this feature is not used, the transmitter keys even if the group is busy.

When the transmitter is disabled by this feature, the busy tone sounds briefly and “DSBL BSY” is indicated on the lower line of the display (high tier only). The monitor mode (see preceding section) is then enabled while the PTT switch is pressed so that activity on the channel can be monitored. It is not possible to access a channel by holding down the PTT switch (it must be released to make another attempt).

Some repeaters may have delayed drop-out (hang time) which causes this feature to disable the transmitter even though no busy condition exists. If this is a problem, there is the option with this feature to allow transmitting if the correct receive Call Guard tone or code is detected. Alternatively, the transmitter can always be keyed by releasing the PTT switch and then pressing it again within 1 second.

### 3.9.3 RECEIVE-ONLY GROUPS

Conventional groups can be PC programmed so that transmitting is disabled (monitoring only is allowed). This is done by not programming a transmit frequency. If the PTT switch is pressed with one of these groups selected, the intercept tone sounds and “TX DSBL” is displayed (high tier only).

### 3.9.4 TALK-AROUND

Normally, all transmissions go through a repeater. However, there may be times when a user is out of range of the repeater system and unable to talk to anyone even though the mobile being called may be only a short distance away. In this situation, the repeater talk-around feature can be used to transmit on the receive frequency so that the transmission does not have to go through a repeater.

Any conventional group can be programmed for talk-around (if talk-around is enabled at the system level). Talk-around is then enabled by simply selecting one of those groups. There is no talk-around indicator when it is automatically selected in this manner unless it is indicated by the group alpha tag (high tier only).

With high tier models, talk-around can also be selected by the TA option switch if the selected group is programmed “Talk-Around = No”. When talk-around is enabled by this switch, “TA ON” is flashed in the display, and when it is disabled, “TA OFF” is flashed. If the selected group is programmed Talk-Around = Yes, talk-around cannot be turned off by the switch. This would be indicated if neither “TA ON” or “TA OFF” is flashed when the switch is pressed.

When another system or group is selected, transceiver power is cycled, or scanning is enabled, talk-around always reverts to the default condition programmed for the group. If talk-around is disabled at the system level, it cannot be selected by the TA switch (“NO TALK” is flashed if it is pressed) and it cannot be programmed on any of the groups in that system.

### 3.9.5 CALL GUARD SQUELCH

#### Introduction

Tone, digital, or inverted digital Call Guard squelch can be programmed on each transmit and receive channel in any order desired. There is also an option to disable the reverse burst or turn-off code on transmit channels programmed with Call Guard squelch. The reverse burst and turn-off code are always detected on receive channels programmed with Call Guard squelch (if it is sent).

The Call Guard squelch feature eliminates distracting messages intended for others using the channel. This is done by using a subaudible tone or digital code to control the squelch. This tone or code is unique to a user or a group on that channel. This tone or code is transmitted with the voice signal but is not heard because it is in the subaudible range and is attenuated by a filter. Call Guard squelch must be used in both the transmitting and receiving transceiver to be functional.

#### CG Option Switch (High Tier Models)

With high tier models only, a CG option switch can be programmed. This switch disables both receive and transmit Call Guard squelch on the selected system/group (the monitor mode disables only receive squelch control). It does not affect squelch control on other system/groups, or the operation of external decoders. When Call Guard squelch is disabled by this switch, “CG OFF” is momentarily displayed. Conversely, when it is enabled, “CG ON” is displayed. The CG On mode is automatically re-enabled when the selected system/group is changed or transceiver power is cycled.

#### Tone Call Guard Squelch

Tone-type Call Guard squelch utilizes subaudible CTCSS tones from 67-254.1 Hz. Although there are 42 tones assigned, those above 33 are normally not used because of their close proximity to the voice band which starts at 300 Hz. In addition, tones 11, 39, 40, 41, and 42 are normally not used because they may cause interference with adjacent tones (see Table 4-5). A reverse burst can be transmitted when the push-to-talk switch is released to eliminate the squelch tail (noise burst) in the receiving transceiver. However, both the transmitting and receiving transceiver must be equipped with this feature for it to be utilized. The reverse burst is a 180-degree phase reversal for a period of time determined by the tone frequency.

#### Digital Call Guard Squelch

Digital Call Guard squelch (CDCSS) uses digital data instead of subaudible tones to control the squelch. This data consists of continuous repetitions of 23-bit words. No bit or word synchronization information is

used. When the push-to-talk switch is released, a turn-off code is transmitted which eliminates the squelch tail similar to the reverse burst.

Although there are thousands of possible code combinations with 23 bits, only 83 are unique with the data scheme used. The number specified when the code is programmed is actually a seed for a special algorithm used to generate the 23-bit data word. The data is transmitted at a rate of 134.4 bits per second. Therefore, approximately six words are transmitted each second. When the data is decoded, 23-bit samples are taken and then the bits are rotated to determine if a valid code was received.

Digital Call Guard squelch can be programmed as normal or inverted. The only difference is that the waveform is inverted when "iDCG" is selected. The inverted type may need to be programmed if the signal is inverted by the repeater or another transceiver. If digital Call Guard squelch does not function, try changing to the other type.

### 3.9.6 PRIORITY GROUP SAMPLING

*NOTE: Conventional priority groups are not sampled while listening to an LTR call, when both system and group scanning are off, or when transmitting.*

The priority group sampling feature ensures that messages on conventional priority groups are not missed while listening to messages on conventional non-priority groups. The sampling frequency of the first priority group is programmable for 500 ms or 1 or 2 seconds. The second priority group is scanned at least every 2 seconds. Call Guard squelch or external squelch control is detected on each if it is programmed. The first priority group is sampled while listening to a message on a second priority group, but not vice versa. When the message on the priority group is complete, the transceiver returns to the previous system/group, and if a message is still present, it is received.

Priority groups can be programmed as follows:

- Fixed first and/or second priority system/groups can be designated by programming.
- The first or second priority system/group can be programmed to follow the selected system/group.

- No priority system/groups can be programmed. A second priority group cannot be programmed if there is no first priority group.

*NOTE: The display messages and menu parameter mentioned in the following information are not available with low tier models.*

When a first priority group is selected or displayed, **P** is indicated in the display. Likewise, when a second priority group is selected or displayed, **P<sub>2</sub>** is indicated. When scanning, these symbols are displayed only when a call is received on the particular priority group. When a message is detected on the first priority group, a tone sounds (if tones are enabled), "PRIORTY1" is indicated on the bottom line for 2 seconds, and the priority message is received. Likewise, if a message is received on a priority 2 group, a tone sounds and "PRIORTY2" is displayed.

If the menu PRIORITY parameter is available (high tier models only) or an option switch is programmed for the priority function, priority sampling can be turned on and off by the user (see Section 3.6.17). When priority sampling is enabled by this switch, "PRI ON" is flashed in the display, and when it is disabled, "PRI OFF" is flashed.

When a first priority system/group is sampled while listening to a message on some other system/group, a series of "ticks" may be heard. These ticks are brief interruptions of the audio signal that occur when sampling takes place. In some cases, the length of these interruptions may increase to the point that makes understanding a message difficult. This is especially true if Call Guard squelch is being detected. The interruption could then be up to 420 ms. If a carrier and incorrect Call Guard signal are detected on the first priority group, the first priority sampling rate changes to 2 seconds. This is called Adaptive Hole Scan (AHS). Refer to the ATS description in Section 3.7.7 for more information.

### 3.9.7 EXTERNAL ENCODERS AND DECODERS

#### General

Groups in conventional systems can be programmed to operate with an external encoder/decoder such as a two-tone or DTMF type. The

scquelch control output from the decoder is the IN2/IN3 wire-outs of the option slots on the audio/logic board. Outputs which may control a decoder or encoder are the OUTPUT A and B wire-outs. These are CMOS outputs with a 470-ohm series resistance and a typical maximum source and sink current of 2 mA.

To program the transceiver for external encoder or decoder operation, the I/O lines just described must be programmed for the desired function and active state as described in Section 4.9. In addition, the applicable conventional group must be programmed for AND EXT = Yes as described in the following information.

#### Decoder (Receive Mode) Operation

If an external decoder is to be used, program the applicable conventional group for AND EXT = “Yes”. (RX CCG category). The Call Guard and external decoder functions are “ANDed” which means that both Call Guard squelch (if programmed) “and” an external decoder must detect the proper code for the receiver to unsquelch. If “None” is entered for the Call Guard type then only the proper external decoder code is required.

The input control line that is used (IN2 or IN3) then must be programmed for the “Ext Call Guard Sq” function (see preceding paragraph). If the active state of this line is programmed “high”, a high output from the decoder unsquelches the receiver (unmutes the audio). Conversely, if the active state is low, a low signal unsquelches the receiver.

Once the receiver unsquelches, it remains in that condition until the control line from the decoder changes states or a carrier is no longer detected. To use the microphone hanger as a decoder reset line, an output line such as Output A or B can be programmed for the “Monitor Hanger” function. If the active condition is “high”, this line is high when the microphone is on-hook and low when it is off-hook. Operation of this line is not affected when off-hook detection is disabled, and the Monitor option switch does not control this function.

#### Encoder (Transmit Mode) Operation

If an external encoder or encoder/decoder is used to transmit a special sequence when the PTT switch is

pressed, program the applicable conventional group for AND EXT = “Yes” (TX CCG category). As in the receive mode, the Call Guard and external decoder functions are “ANDed”. Therefore, if transmit Call Guard squelch is programmed, it is also transmitted.

The output control line that is used (Output A or B) then must be programmed for the “Send Call Guard Sq” function and the desired active state. Then when the transmitter is keyed, this line goes to the active state and shortly after, the Transmit line goes high. These lines then go back to the inactive state when the transmitter is unkeyed.

#### Scanning With An External Decoder

Groups programmed for both Call Guard squelch and an external decoder are scanned for the normal period (see Section 3.7.7). If only an external decoder is programmed on a group, it is scanned for a fixed period of 200 ms to determine if the correct code is detected. If an external decoder is programmed on a priority group, the external decoder is not detected.

### 3.10 SUPERVISORY TONES AND DISPLAY MESSAGES

#### 3.10.1 GENERAL TONES

*NOTE: The display messages and menu parameters mentioned in the following information are not available with low tier models.*

The following tones are heard at various times when operating this transceiver. Some or all of these tones can be disabled by the user if the menu “TONES” parameter is available (see Section 3.6.26). If the menu parameter is not available, these tones can be selected only by the PC programmer.

**Busy Tone** - This tone is similar to the standard telephone busy tone, and it indicates that the LTR radio system is currently busy. It is produced by turning combined 480 and 620 Hz tones on and off at a 4 Hz rate. This tone sounds with all types of LTR calls (even if the proceed tone is enabled), and “BUSY” is indicated on the lower line of the display when it sounds. It does not sound on conventional systems.

Repeated access attempts are made while the PTT switch is pressed with this tone sounding. Therefore, it is not necessary to release the PTT switch to access the system.

**Intercept Tone** - This is a siren-like tone (alternating high and low tones) consisting of 700 Hz and 800 Hz tones alternating at approximately a 2 Hz rate. This tone indicates the following out-of-range and error conditions:

- **Out-Of-Range** - If this tone sounds 2-3 seconds after pressing the PTT switch and “OUT RNGE” is displayed, the data handshake with the repeater could not be completed. The usual cause is an out-of-range condition. Six attempts are made before this tone sounds. No more access attempts are then made until the PTT switch is released and then pressed again.
- **Time-Out Timer** - If this tone sounds after the transmitter has been keyed for an extended period and “TIMEOUT” is displayed, the transmitter has been disabled by the Time-Out Timer feature (see Section 3.5.16). This tone sounds in all operating modes. Ten seconds before this tone sounds, a single high beep (1400 Hz) sounds to indicate that time-out will soon occur.
- **Transmit Inhibit** - If this tone sounds as soon as the PTT switch is pressed with an LTR system selected and “TX INHIB” is displayed, the transmitter has been disabled by the Transmit Inhibit feature (see Section 3.8.6).
- **Transmit Disable On Busy** - If this tone sounds as soon as the push-to-talk switch is pressed with a conventional group selected and “DSBL BSY” is displayed, the channel is busy and the transmitter was disabled by the Transmit Disable On Busy feature (see Section 3.9.2).
- **Receive-Only Channel** - If “TX DSBL” is displayed when this tone sounds, a conventional receive-only channel is selected (see Section 3.9.3).
- **Tx While Receiving Call** - If the push-to-talk switch is pressed while receiving an LTR call, this tone sounds and “DSBL BSY” is displayed.

**Proceed (Clear-To-Talk) Tone** - This is a short (700 Hz, 50 ms) tone which sounds after the push-to-talk switch is pressed to indicate when talking can begin (see Section 3.5.13).

**Key Press Tone** - This is a short (700 Hz, 50 ms) tone that sounds to indicate when an option switch is pressed (in all modes). It is also used to confirm that the System Search mode has been selected.

**Priority Call Tone** - This is a 1050 Hz, 50 ms tone that sounds when a call is received on a conventional first or second priority channel (see Section 3.9.6).

**Wrap-Around Tone** - A 700 Hz, 80 ms tone followed by an 800 Hz, 80 ms tone which indicates that the highest or lowest programmed system or group was displayed and that wrap-around has occurred (see Section 3.4.5).

**Error Tone** - A 1050 Hz, 80 ms tone followed by a 700 Hz, 80 ms tone which indicates that an error condition occurred.

### 3.10.2 LTR TELEPHONE CALL TONES

The following tones are generated by the LTR interconnect equipment and are heard when making LTR telephone calls.

**Reorder Tone** - Three beeps which indicate that the call has been terminated by the system.

**Return Time Warning Tone** - Two beeps which warn that you have not transmitted for an extended period. If you do not transmit within 5 seconds, the call is automatically terminated by the system. The time between transmissions is one of the parameters used by the system to detect the end of a call when the # character is not sent.

**Conversation Time-Out Tone** - Calls are limited to a certain length by the system. Thirty seconds before this time is reached, a “tick” begins sounding each second. When the 30-second time expires, the call is automatically terminated by the system.

**Turn-Around Tone** - This is a single beep which may be used to indicate to the landside party when to respond to your transmission. It sounds when you

release the PTT switch, and you may partially hear this tone.

**Proceed Tone** - This tone consists of two beeps and it tells the landside caller when to enter the five-digit number specifying the mobile being called. Dialing of this number must be started within 5 seconds of hearing this tone, and a tone-type telephone must be used.

### 3.10.3 DISPLAY MESSAGES

#### Low Tier Display Messages

Error conditions are indicated by the LED display as follows:

“**—**” - If only the middle segment in the right seven-segment number display is on, it indicates that the synthesizer is unlocked. The transceiver is nonfunctional until lock is re-established.

“**U**” - If an uppercase “U” is displayed in the seven-segment display, it indicates that the transceiver is on a system/group that is not programmed for any of the displayed channel numbers. Unassigned system/groups are not permitted with low tier models. Refer to Section 4.6.5 for more information. If making data transmissions, this indicates that either no data group or no voice group is available (see Appendix A.4.1).

“**17**” - This indicates a type error. It is displayed after programming to indicate that the transceiver is programmed with a file type intended for a different model or tier. Reprogram the transceiver with the correct file type. If this problem persists, flash ROM U108 or microcontroller U101 may be defective.

“**19**” - This indicates a programming error. Try reprogramming the transceiver. If the problem persists, flash ROM U108 may be defective.

#### High Tier Display Messages

The following messages appear in the display of high tier models to indicate various operating modes and error conditions. Selected system/group information appears in this display during normal operation (see Section 3.4.4).

**BLK CALL** - Indicates that the call is being received on an LTR block ID code (see Section 3.8.3).

**BUSY** - Indicates that the LTR radio system is currently busy (see “Busy Tone” in Section 3.10.1).

**CG ON or OFF** - Indicates the Call Guard squelch was just enabled or disabled by the CG option switch (see Section 3.9.5).

**DATA GRP** - Indicates that no valid voice group can be found for the transmission (see Appendix A.4.1).

**DSBL BSY** - Indicates that the transmitter is disabled by the conventional Transmit Disable On Busy feature (see Section 3.9.2). It also indicates that the transmitter was keyed while receiving an LTR call.

**EMERGENCY** - Indicates that the emergency switch has been pressed (see Section 3.5.6).

**FCN** - Indicates that the function select mode is selected by the FCN switch (see Section 3.5.8).

**GSCN DIS** - Indicates that an attempt was made to delete a group from the scan list with group scanning disabled (see Section 3.7.2).

**IN QUEUE** - Indicates that the call has been placed in queue by the LTR Busy Queuing feature (see Section 3.8.7).

**Model** - The last seven digits of the transceiver part number (see Section 1.3) are displayed very briefly on the top line of the display when transceiver power is turned on. The eighth display digit is reserved for future use and is always “0”. For example, a high tier, 800 MHz, 30 watt, LTR transceiver is displayed as “98832203”.

**NO DT GP** - Indicates that no valid data group could be found for the transmission (see Appendix A.4.1).

**NO PHONE** - Indicates that the LTR system search mode could not access a system programmed for telephone calls (see Section 3.8.8).

**NO POWER** - Indicates that the transmitter temperature is excessive and the transmitter has been shut down (see Section 3.5.18).

**NO TALK** - Indicates that talk-around has been disabled on the selected conventional system by programming (see Section 3.9.4).

**NOT CONV** - Indicates that an attempt was made to enable a conventional mode feature on an LTR system.

**OUT-LOCK** - Indicates that the synthesizer is unlocked. The transceiver is nonfunctional until lock is re-established.

**OUT-RNGE** - Indicates an out-of-range condition. Once this indication appears, no more access attempts are made until the PTT switch is released and then pressed again (see Section 3.10.1).

**PRI ON or OFF** - Indicates that priority sampling was just enabled or disabled by the PRI option switch (see Section 3.9.6).

**PRIORITY1 or 2** - Indicates that an LTR or conventional call is being received on one of the priority ID codes or groups (see Sections 3.8.3 and 3.9.6).

**PROG ERR** - Indicates an EEPROM read error. Check transceiver programming or the EEPROM if this condition persists.

**PRG MODE** - Indicates that the transceiver is being programmed.

**SQUELCH** - Indicates that the conventional squelch adjust mode is selected (see Section 3.4.6).

**SYS SRCH** - Indicates that the LTR System Search mode has been entered (see Section 3.8.8).

**TA ON or OFF** - Indicates that talk-around was just enabled or disabled by the TA option switch (see Section 3.9.4).

**TIMEOUT** - Indicates that the transmitter has been disabled by the Time-Out Timer (see Section 3.5.16).

**TX DSBL** - Indicates that the selected conventional system is programmed for monitoring only (see Section 3.9.3).

**TX INHIB** - Indicates that the transmitter has been disabled by the Transmit Inhibit feature (see Section 3.8.6).

### 3.10.4 MENU MODE MESSAGES (HIGH TIER ONLY)

The following messages are displayed in the menu mode that is described starting on page 15. "ON" is displayed to indicate enabled or yes, and "OFF" is displayed to indicate disabled or no. The menu mode is not available with low tier models.

**BCKLHGT** - Backlight

- **BRIGHT**
- **DIM**
- **OFF**

**BANK SEL** - Bank select

- **Alpha tag of programmed banks**

**ENCRYPT** - Encryption on-off

- **ON or OFF**

**HRN ALRT** - Horn alert

- **ON or OFF**

**OPTION** - Option on-off

- **ON or OFF**

**PRIORITY** - Conventional priority group sampling

- **ON or OFF**

**SCN CONT** - Scan continue on-off

- **ON or OFF**

**SCN SAVE** - Scan list save

- **ON** = save, **OFF** = not saved

**SCN TYPE** - Selects type of scanning

- **SYS-GRP** - Both system and group
- **GRP ONLY** - Group scanning only
- **OFF** - Scanning off, switch disabled

**S/G DISPL** - Sys/grp display mode (high tier only)

- **ON or OFF**

**STEALTH** - Stealth mode select (high tier only)

- **ON or OFF**

**SYS SRCH** - LTR system search

- **ON** or **OFF**

**TALKARND** - Conv. talk-around mode select

- **ON** or **OFF**

**TONES** - Tone type select

- **SILENT** - No tones sound
- **KEY BEEP** - Only the Select switch (high tier only) and key press tones sound
- **ALERT** - All tones except preceding Key Beep tones sound
- **ALL TONE** - The preceding Key Beep and Alert tones sound

**3.11 TEST MODE**

**3.11.1 HIGH TIER OPTION SWITCH IDENTIFICATION**

Option switches are used in the test mode to select various functions. Since all five switches are programmable with high tier models, the labels may vary. Therefore, they will be referred to by the numbers indicated in the following illustration.

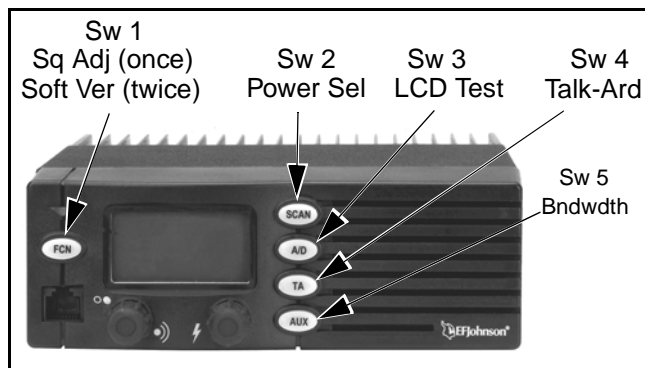

**High Tier Option Switch Numbering**

**3.11.2 ENTERING TEST MODE**

The test mode is selected by turning power on with the following option switch(es) pressed:

Low Tier Models - A/D switch

High Tier Models - Switches “2” and “3”

*NOTE: The test mode cannot be selected by turning power on with the TxD and RxD lines of the microphone connector shorted together.*

When power comes up in the test mode, the last Channel (low tier) or System and Group (high tier) selected in the test mode is displayed. In addition, with the high tier only, the bottom line indicates the software version number as “00312xx0” (see Section 3.12.4). To display the frequency on the bottom line (and the next channel), rotate the Select switch one click or press the PTT switch.

**3.11.3 EXITING TEST MODE**

To exit the test mode, turn radio power off and on without any front panel switches pressed.

**3.11.4 TEST MODE DEFAULT CONDITIONS**

The radio goes into the following conditions when powered up in test mode:

- Test Channel - Last Selected (System 1-16)
- Test Modulation - Last Selected (Group 1-7)
- Receiver is on and in carrier squelch mode
- Transmitter is off, set for high power
- Channel bandwidth is set to 25 kHz
- Selector switch defaults to system select.

**3.11.5 TEST CHANNEL SELECTION**

When in test mode, 16 programmable test frequencies are available. Test frequencies are selected by the System (Channel) select function in the normal manner. Test channels are programmed using the PC programmer (see Section 4.6.2). If the default test frequencies are not changed, the channels shown in Table 3-4 are programmed.

**3.11.6 MODULATION SELECTION**

Low Tier Models

In the test mode, various modulation schemes are chosen by pressing the A/D switch and then the CHL up/down switches. The modulation select mode is indicated by “+” in the display. A modulation mode remains selected as long as the test mode is selected (even if the channel is changed or power is cycled). The modulation type selected by each display number is shown in Table 3-3.



### High Tier Models

Test mode modulation is chosen by selecting groups in the normal manner. The modulation type selected by each group is shown in Table 3-3.

#### 3.11.7 MISCELLANEOUS

When in test mode, normal operation is half-duplex with the Rx audio controlled by the carrier squelch circuit. The only exception to this is on Groups 4, 5, 6, and 7 when the Rx audio is controlled by the reception of the proper Call Guard signal.

To transmit in test mode, the PTT switch is pressed. The receiver is disabled when in the transmit mode. The volume is adjustable in the normal manner by pressing the VOLUME buttons or rotating the volume knob. The squelch can also be adjusted in the normal manner as described in Section 3.4.6 (press AUX1 with low tier models).

### Low Tier Models

The other two option switches on the front panel perform the following functions in the test mode:

**SCAN (High/Low Power)** - Toggles between high and low transmitter power. Low power = green Scan LED is lighted.

**A/D (Modulation Select)** - Enables the modulation select mode as described in Section 3.11.6.

**AUX1 (Squelch Adjust)** - Selects the squelch adjust mode. When this mode is selected, the AUX1 decimal point is lighted.

*NOTE: With low tier models, when the preceding squelch adjust mode is selected, the modulation set mode (indicated by "+") is disabled.*

**AUX2 (Bandwidth)** - Toggles the radio channel bandwidth setting between 12.5 and 25 kHz channels. When the 12.5 kHz mode is selected, the AUX2 decimal point is lighted.

**Talk-Around Select** - The talk-around mode is toggled in the modulation select mode when the display "rolls over" from group "9" to "1" or vice

**Table 3-3 Test Mode Modulation Schemes**

Group	Modulation Scheme
1	No subaudible signaling, microphone audio is enabled in transmit mode, carrier squelch is enabled in receive mode.
2	134 Hz square wave signal transmitted with the transmit data filter enabled, microphone audio muted (data deviation test mode).
3	200 Hz square wave is transmitted with the transmit data filter bypassed, microphone audio muted (modulation balance test mode).
4	67 Hz tone Call Guard signal transmitted, microphone audio is enabled, 67 Hz tone is also decoded in receive mode (tone Call Guard squelch test mode).
5	210.7 Hz tone Call Guard signal transmitted, microphone audio is enabled, 210.7 Hz tone is also decoded in receive mode (tone Call Guard squelch test mode).
6	Digital Call Guard code 532 is transmitted, microphone audio enabled, code 532 is also decoded in receive mode (digital Call Guard squelch test mode).
7	A valid LTR word is transmitted and received to allow LTR word testing in an LTR test system (LTR test mode)
8	Enable compandor using I/O line and active state programmed for companding as described in Section 4.9. Modulation same as Group 1.
9	Enable encryption using I/O line and active state programmed for encryption as described in Section 4.9. Modulation same as Group 1.

around mode is indicated by the "-" indicator (scan list status).

### High Tier Models

The option buttons on the front panel perform the following operations in the test mode. The high tier option switch reference number is shown in brackets ([ ]). Refer to Section 3.11.1 for more information.

**FCN [1] (Squelch Set/Version No.)** - Pressing FCN once displays "FCN" on the lower line of the display. Then rotating the Select switch within 8 seconds sets the squelch level in the normal manner (see Section 3.4.6). Pressing FCN twice displays the software version number.

Table 3-4 Default Test Channels

Sys (Chnl)	430-470 MHz		470-512 MHz		800 MHz		900 MHz	
	Rx Freq	Tx Freq	Rx Freq	Tx Freq	Rx Freq	Tx Freq	Rx Freq	Tx Freq
1	430.000	430.000	470.000	470.000	851.000	806.000	935.000	896.000
2	435.000	435.000	470.00625	470.00625	852.000	807.000	935.250	896.250
3	440.000	440.000	475.000	475.000	853.000	808.000	935.500	896.500
4	440.00625	445.00625	480.000	480.000	854.000	809.000	935.750	896.750
5	447.99375	447.99375	480.00625	480.00625	855.000	810.000	936.000	897.000
6	448.99375	448.99375	485.000	485.000	856.000	811.000	936.250	897.250
7	449.000	454.000	490.99375	490.99375	857.000	812.000	936.500	897.500
8	449.00625	449.00625	491.000	491.000	858.000	813.000	937.000	898.000
9	450.000	450.000	491.00625	491.00625	860.000	815.000	937.500	898.500
10	450.00625	450.00625	495.000	495.000	861.000	816.000	938.000	899.000
11	452.000	452.000	498.000	498.000	863.000	818.000	938.500	899.500
12	452.00625	452.00625	502.000	502.000	864.000	819.000	939.000	900.000
13	460.000	460.000	502.00625	502.00625	865.000	820.000	939.500	900.500
14	460.00625	465.00625	507.000	507.000	867.000	822.000	940.000	901.000
15	465.000	465.000	511.99375	470.000	868.000	823.000	940.500	901.500
16	470.000	470.000	512.000	470.00625	870.000	825.000	941.000	902.000

**SCAN [2] (High/Low Power)** - Toggles between high and low transmitter power. The low power mode is indicated when the priority icon **P** is displayed.

**A/D [3] (LCD Test)** - Initiates a test of the display.

**T/A [4] (Talk-Around)** - The talk-around mode is toggled by pressing this key. When talk-around is enabled, TA ON is momentarily displayed, and when talk-around is disabled, TA OFF is displayed.

**AUX [5] (Bandwidth)** - Toggles the radio channel bandwidth setting between 12.5 and 25 kHz channels. When the 12.5 kHz mode is selected, the encryption icon **Q** is displayed.

### 3.12 ELECTRONIC PART, IDENTIFICATION, AND SOFTWARE VERSION NUMBERS

#### 3.12.1 INTRODUCTION

Low and high tier and also the data models of this transceiver have the part number, identification number, and operating software version number permanently stored in memory on the audio/logic board. The information which follows describes how these numbers are viewed.

#### 3.12.2 VIEWING ELECTRONIC PART NUMBER

Proceed as follows to view the part number that is stored electronically in the transceiver. The information contained in this number is described in Section 1.3.

**High Tier Models** - Digits 4-10 of the part number are briefly displayed on the top line of the display when power is turned on. Refer to Section 3.4.1 for more information.

**All Models** - Using the personality programming software, upload a file from the transceiver. Digits 4-10 of the part number are then indicated after "Radio Model" near the top of the screen. Refer to Section 4.5.5 for more information.

#### 3.12.3 VIEWING ELECTRONIC IDENTIFICATION NUMBER

The transceiver identification number described in Section 1.4 is located on labels on the inside and outside of the transceiver and is also stored electronically. The personality programming software can be used to read the electronic identification number as follows:

Connect the transceiver as described in Section 4 and then press the F7 key from the Main Menu screen. A screen is then displayed which indicates the information in this number. Refer to Section 4.5.1 for more information on this function.

### 3.12.4 VIEWING SOFTWARE VERSION NUMBER

The version number of the operating (Flash) software contained in a transceiver can be determined as follows:

#### Using Test Mode (High Tier Only)

When the test mode is selected by turning power on with option switches 2 and 3 pressed (see Section 3.11), the software version number is indicated as “003x2xx0” on the bottom line of the display. The breakdown of this number is as follows:

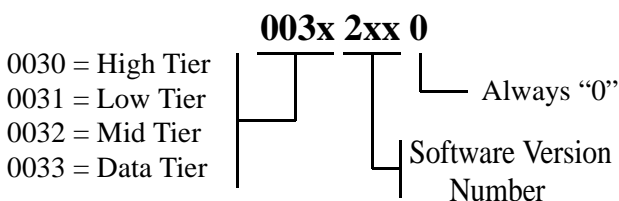

#### Using Display Test Function (Low Tier Only)

Both low and high tier models have a display test function that individually enables the various segments and icons in the display. This display test function is enabled by turning power on with the following option switches pressed:

Low Tier Models - A/D and AUX1

High Tier Models - “3” and “5” (see Section 3.11.1).

With low tier models only, in addition to enabling each segment, the software version number is flashed by the right-most digit of the display at the end of the test sequence. After hyphens are indicated by each display, the display flashes “00312xx0” in sequence. A breakdown of this number is shown in the preceding description.

#### Using Personality Programming Software

With all models including low and high tier and data, the tier and software version number are displayed in the lower left corner of the Upload screen while uploading data. Refer to Section 4.5.5 for more information.

With data models, this is the only method that can be used to determine the software version number since they do not have a display. The tier of these transceivers is indicated as “DT” (Data Tier).

## SECTION 4 PROGRAMMING

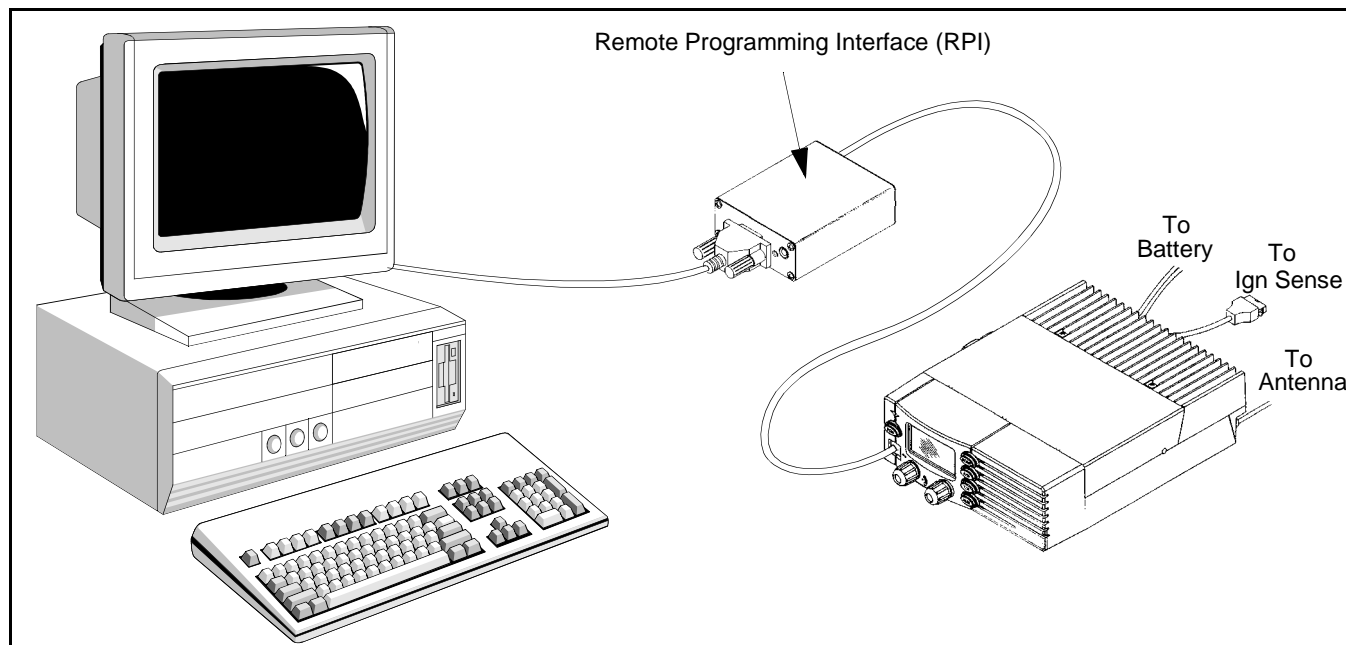

Figure 4-1 Programming Setup

## 4.1 GENERAL

*NOTE: This section describes the -414 software that is used to program LTR models. LTR-Net models are programmed with different software (-457) that is described in a separate addendum.*

*NOTE: Version 205 or later personality programming software is required to program 470-512 MHz LTR models, and Version 207 or later is required to program data models.*

## 4.1.1 PROGRAMMING SETUP

The following items are required to program the transceiver. The part numbers of this equipment are shown in Table 1-3 in Section 1. A programming setup is shown above.

- IBM® PC or compatible personal computer
- EFJohnson Remote Programming Interface (RPI), Part No. 023-9800-000.
- Cables from the RPI to the computer and radio.
- EFJohnson programming software for 9800-series transceiver (see “NOTE” above).

## 4.1.2 MINIMUM COMPUTER REQUIREMENTS

The programming software is designed to run on an IBM PC or compatible computer that meets the following *minimum* requirements:

- 640K of memory
- 286 or faster microprocessor. Computers with 8086/8088 microprocessors cannot be used (such as XT compatibles).
- The personality program and help file use about 540K of disk space and are supplied on a 3-1/2” 1.44 M diskette only. Therefore, a computer with a hard disk drive and 3-1/2” (1.44M) floppy drive is required:
- MS-DOS version 5.0 or higher (Windows 3.1/95/98/NT not required)
- One unused serial port
- Monochrome or color monitor

Although the program uses color to highlight certain areas on the screen, a monochrome (black and white) monitor also provides satisfactory operation. An unused serial port is required to connect the RPI to the computer. One or two serial ports are standard with most computers. One port may be used by the mouse.

### 4.1.3 RPI CABLES

The cables from the RPI to the computer and transceiver are not included with the RPI. The RPI has a female DB9 connector, and most computer serial ports have a male DB9 or male DB25 serial connector. Therefore, a male DB9 to female DB9 or female DB25 cable is usually required. This is a standard cable available at most electronic and computer supply stores. Suitable cables are also available from the EFJohnson Company (see Table 1-3).

The cable from the RPI to the transceiver has modular telephone-style connectors on each end. It plugs into the microphone jack on the front panel of the transceiver or remote control unit. The cable for this application is also listed in Table 1-3.

### 4.1.4 REMOTE PROGRAMMING INTERFACE (RPI)

The RPI provides the required interface between the computer and transceiver. It converts the RS-232 logic levels from the computer to the TTL logic levels required by the transceiver microprocessor and vice versa.

A new RPI (Part No. 023-9800-000) has been designed for this transceiver. This RPI is backward compatible, so it can also be used to program other EFJohnson transceivers which require an RPI (see next paragraph for more information). This new RPI is required for Flash programming described in Section 4.8. It also has a phone jack that is required for injecting the transmit audio signal during alignment (see Section 7). To perform the standard personality programming described in most of this section, earlier RPI's such as Part No. 023-5810-000 or 023-9750-000 can be used.

When programming both front and remote models of this transceiver, the switch on the front panel of the RPI selects either the standard or Flash programming mode. The standard mode is selected when it is away from the LED and the indicator is green, and the Flash mode is selected when it is toward the LED and the indicator is amber. The standard mode should be selected for all but Flash programming.

With some remote mount transceivers (not 9800 series), this switch is used to turn transceiver power on and off. A separate 9-16 VDC, 200 mA power supply (such as P.N. 563-0001-005) must then be plugged into the RPI power jack to provide power to the RPI.

### 4.1.5 EEPROM DATA STORAGE

Most personality information programmed in the following sections is stored in the Flash memory device (U108). An EEPROM that is part of the micro-computer chip is used to store such things as alignment parameters and current switch settings. Both Flash and EEPROM devices store data indefinitely without the need for a constant power supply. The transceiver can be removed from the vehicle or even stored on a shelf indefinitely without affecting programming. They are also reprogrammable which eliminates the need for a new device if personality information or the operating program is changed.

If the operating program needs to be updated, reprogramming is performed using the same setup and special Flash programming software. The procedure for reprogramming the Flash memory is described in Section 4.8.

### 4.1.6 HARDWARE HOOKUP

The programming setup is shown in Figure 4-1. The cable from the RPI to the transceiver is connected from the modular jack of the RPI to the microphone jack on the front panel of the transceiver or remote control unit. Data transceivers are also programmed using the jack on the front panel.

The RPI has a switch which selects standard or Flash modes with 9800-series models. Make sure that the standard mode (position away from the LED) is selected. This mode is indicated by a green LED when power is applied.

### 4.1.7 POWERING UP A DATA TRANSCEIVER

Data transceivers do not have any front panel controls as shown in Figure 1-1. Therefore, there is no power switch to turn power on and off for programming. One method that can be used to turn power on is to jumper two pins of the 10-pin connector on the RPI. Connect a jumper from Pin 1 to Pin 2 as shown in the

following illustration. The following components can be used to fabricate a jumper if desired:

Connector housing (2-pin) - P.N. 515-7020-102

Connector pins (2 req'd) - P.N. 517-7110-001

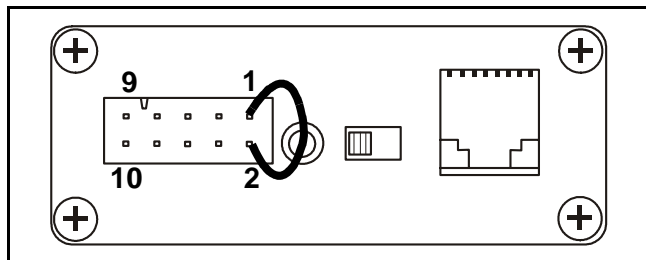

**RPI 10-Pin Connector Numbering**

*NOTE: With 9800 series transceivers, the switch on the RPI cannot be used to switch power because it selects the standard or Flash programming modes as described earlier.*

## 4.2 SOFTWARE INSTALLATION INFORMATION

### 4.2.1 GENERAL

The Personality, Flash, and Radio Tune programs run from the DOS operating system. Therefore, if they are run from within the Windows 3.x, 95, or NT operating system, they run in the DOS mode. The Personality programming software can probably be run from Windows 95 and NT, but not 3.x. Flash programming usually must be performed from DOS. If the program does not run correctly in Windows, select the DOS mode, not the DOS prompt (Windows 95), reboot in the DOS mode (NT), or exit Windows (3.x). The program is then run from the DOS prompt (such as C:\>).

### 4.2.2 MINIMUM FREE MEMORY REQUIRED

*NOTE: With Windows 95 and NT, memory management is handled automatically and the following does not apply.*

Approximately 585K of free conventional memory is required to run this program with help information. If you have at least 640K of memory and not enough is available, there may be other programs that are also being loaded into conventional memory.

To check the amount of memory available, use the DOS MEM command if available.

To make more memory available, the DOS MEMMAKER program can be run to automatically optimize your memory configuration. A DOS boot disk may also be used to start the computer without loading non-essential programs into memory. Refer to the documentation included with your computer for more information on how to make more memory available.

If you have at least 515K of free memory, the program can be run if the help information is not loaded. To run the program in this mode, type PLATFORM NOHELP on the DOS command line when the program is started (see Section 4.2.4).

*NOTE: Adequate memory space may not be available even if the computer is equipped with several megabytes of memory. This is because most DOS programs run in only the 640k block of conventional memory.*

### 4.2.3 SOFTWARE INSTALLATION

#### Making a Backup Copy

When you receive the programming software, make a backup copy and store the master in a safe place. To make a copy of the distribution disk with Windows 95 Explorer, right click the floppy drive icon and select Copy Disk. With Windows 3.1 File Manager, select Copy Disk from the Disk menu. With DOS, use the DISKCOPY command. For example, type DISKCOPY A: A: with single floppy drive systems, or DISKCOPY A: B: with dual drive systems.

#### Creating a Separate Directory

You may want to create a separate directory on your hard disk for programming. This can be done using Windows Explorer, File Manager, or DOS. For example, to create from DOS a directory called RADIOPRG on drive C:, type C: (Enter) to make it the current directory if necessary. Then type MD \RADIOPRG (Enter). To change to that directory, type CD \RADIOPRG.

### Copying Files to Hard Drive

The Personality, Flash, and Radio Tune programs are not compressed. Therefore, they can be run directly without the need for any type of conversion. The name of the personality program is PLATFORM.EXE and the associated help file is PLATFORM.HLP. These files are approximately 448K and 92K in size, respectively.

The program can be run from the floppy disk, but you will probably want to copy these files to the programming directory of your hard disk. To do this, use Windows Explorer or File Manager or the DOS COPY command.

### Creating a Windows Shortcut or Program Icon

If you want to try and run the program from Windows 95, a shortcut icon can be created that can then be double clicked to start the program. To create this shortcut icon, select Start, Settings, Taskbar. Then select the Start Menu Programs tab and click the Add button. Information is then displayed to guide you through the process. If Windows 3.1 can be used (see Section 4.2.1), select File, New from the program manager and follow the instructions to create an icon for starting the program.

## 4.2.4 STARTING THE PROGRAM

### General

If your computer is running one of the Windows operating systems, double click the icon for the program. If the program does not run properly, Windows must be exited and the program run from the DOS prompt (see Section 4.2.1). When running it from the DOS prompt, make sure the current directory is the one containing the program (see preceding information) and then type PLATFORM to start the program.

### Starting in Monochrome Mode

The program can be started in the monochrome mode if necessary by typing PLATFORM M. This may be necessary if the program does not automatically detect a monochrome video card and the screen is difficult to view.

### Starting Without Help Files

If the amount of free memory available is greater than 515K but less than 585K (see Section 4.2.2), the program can be run if help information is not loaded. To run it in this mode, type PLATFORM NOHELP. If not enough free memory is available, an error message is displayed when the program is started.

## 4.3 MISCELLANEOUS PROGRAM INFORMATION

### 4.3.1 HEADER INFORMATION

The following information is contained in the header area near the top of the screen (see Figure 4-2).

FREE SPACE (AAAA/BBB) - Displays the amount of space remaining in the various nonvolatile memory devices (see following) if the transceiver was programmed with the current information. With high tier models, the maximum number of systems that can be programmed is limited to approximately 40-100 as described in Section 1.2.3. If either of these two numbers reach zero before all data is entered, fewer systems, groups, or channels need to be programmed. If a third number is displayed, it is not used and is always "0".

AAAA = Space remaining in user personality portion of Flash memory U108 and also EEPROM U102 with high tier models. These are the primary storage areas for personality information.

BBB = Space remaining in the microcontroller EEPROM. This space is used mainly for storing tune data.

RADIO MODEL - Displays the specific transceiver configuration that has been selected for the file being edited. The last seven digits of the transceiver part number are used to indicate this information (see Section 1.3).

The configuration is specified when a new file is created by the "Set Up Configuration File" function described in Section 4.5.2. Before data is downloaded, the program checks to make sure that the transceiver is the same type as is specified in the program. If it is not, the information cannot be downloaded. This radio type information specified for the current data file

information can be changed by the “Change Model/Band/Range/Tier” function described in Section 4.6.9. This may be done, for example, to use the current file as a basis to program a different 98xx model.

**File Name** - Displays the name of the transceiver configuration file that is currently being edited. If a new file is created and it has not yet been saved, it is called “NEW”.

#### 4.3.2 SPECIAL KEYS

**Escape** - The Escape key or F9 key is pressed to go back to the preceding screen. If information was changed in the current screen, the changes on that screen are saved in a buffer but not to a disk file.

**Return** - Pressing the Return key (or ENTER on some keyboards) usually executes the changes made to a parameter or screen. The change is saved in a buffer but not to a disk file.

**Arrow Keys** - The arrow keys are usually used to move the cursor or highlight bar to the next or previous parameter.

**Numbers/Letters Preceding Description** - An alternative method for quickly selecting screens or functions is to press the number or letter key preceding the description when applicable.

**F1 (Help Select)** - Displays help information on the selected parameter.

**F2 (Help Screen)** - Displays help information on the displayed screen.

**F3, F4, F5, F6, F7, F8** - Use varies according to the screen that is selected. Refer to the separate screen descriptions for more information.

**F9 (Prove Menu)** - Returns to the previous menu or screen.

**F10 (Exit Program)** - Exits the program and returns to the operating system. Before exit occurs, a prompt appears to allow the current file to be saved. If it is not saved in this manner or has not been previously saved using “Configuration File Utilities” screen, all changes will be lost.

## 4.4 PROGRAMMING PROCEDURE

### Introduction

The following is a general procedure that can be used to program a 98xx-series transceiver. More detailed information on the screens displayed by the program is located in Sections 4.5 - 4.7.

### Getting Started

The Main Menu (see Figure 4-2) that is displayed when the program is started should be on the screen. Proceed as follows:

1. Choose the file to be edited using one of the following methods:
  - When the program is started, the last file edited is automatically loaded if it is in the current directory. If this file is to be edited, proceed to step 2.
  - If a file stored on disk is to be edited or used as a basis for programming another file, select “Open Configuration File” (see Section 4.5.3). The F5 and F6 keys can be pressed to change and display directories.
  - If a new programming file is to be created, select “Set Up New Configuration File”. Enter the radio information described in Section 4.5.2. When the required information has been entered, the “Modify Radio File” menu is automatically displayed. Proceed to “Main Radio Parameters”.
2. Select “Modify Current Configuration File” to display the “Modify Radio File” menu (see Section 4.5.4).

### Main Radio Parameters

The “Modify Radio File” screen shown in Figure 4-3 should be displayed. Proceed as follows:

1. Select “Edit Main Radio Parameters” and the screen in Figure 4-4 is displayed. Program the parameters in this screen as described in Section 4.6.2 and Table 4-1.
2. Press the F6 key to display the channel table. All channel frequencies used for LTR and conventional



systems and groups must first be entered in this table. FCC channel numbers are not used. With high tier models, up to three 126-channel tables can be created for a total of 378 channels.

3. If you want to change any of the default channels selected in the test mode, press the F7 key to display and change the test channel table (see Section 3.11).
4. When all applicable information on the screen has been entered, press F9 or ESC to return to the “Modify Radio File” screen.

### Option Switches

The “Modify Radio File” screen shown in Figure 4-3 should be displayed. Proceed as follows:

1. Select “Define Option Buttons” and the screen in Figure 4-4 is displayed. This screen displays a likeness of the front panel of the transceiver.
2. Program the option switches as described in Section 4.6.3. If a function is assigned to an option switch, it cannot be assigned as a menu function and vice versa.
3. When the switches have been programmed as desired, press F9 or ESC to return to the “Modify Radio File” screen.

### Menu Mode

The “Modify Radio File” screen shown in Figure 4-3 should be displayed. Proceed as follows:

1. Select “Setup Menu Functions” and the screen in Figure 4-5 is displayed. Program the information in this screen as described in Section 4.6.4.
2. When all desired information in the screen has been entered, return to the “Modify Radio File” screen by pressing F9 or ESC.

*NOTE: The channel numbers used to program the following LTR systems and conventional groups are from the channel table(s) programmed in the preceding “Main Radio Parameters” section.*

### Create/Edit/Copy/Delete an LTR System

The “Modify Radio File” screen shown in Figure 4-3 should be displayed. Proceed as follows:

1. To create a new LTR system, select “Create LTR System” and the screen in Table 4-3 is displayed. To edit an already created system, select “Edit System”, to copy another system, select “Copy System”, and to delete a system, select “Delete System”.
2. Program the information in this screen as described in Section 4.6.5 and Table 4-3. Press F4 and F5 to jump between the top and bottom sections of the screen.
3. To display the group table for the system, press F6 and the screen in Table 4-3 is displayed. Program the parameters in this screen as described in Table 4-3.
4. When finished programming the group parameters, return to the “Modify Radio File” screen by pressing F9 or ESC. If creating another LTR system, repeat this section.

### Create/Edit/Copy/Delete a Conventional System

The “Modify Radio File” screen shown in Figure 4-3 should be displayed. Proceed as follows:

1. To create a new conventional system, select “Create Conventional System” and the screen in Table 4-4 is displayed. To edit an already created system, select “Edit System”, to copy another system, select “Copy System”, and to delete a system, select “Delete System”.
2. Program the information in this screen as described in Section 4.6.5 and Table 4-4.
3. To display Group Table 1 for that system, press F6 and the screen in Table 4-4 is displayed. Program the parameters in this screen as described in this table and then press F9 or ESC to return to the system screen.

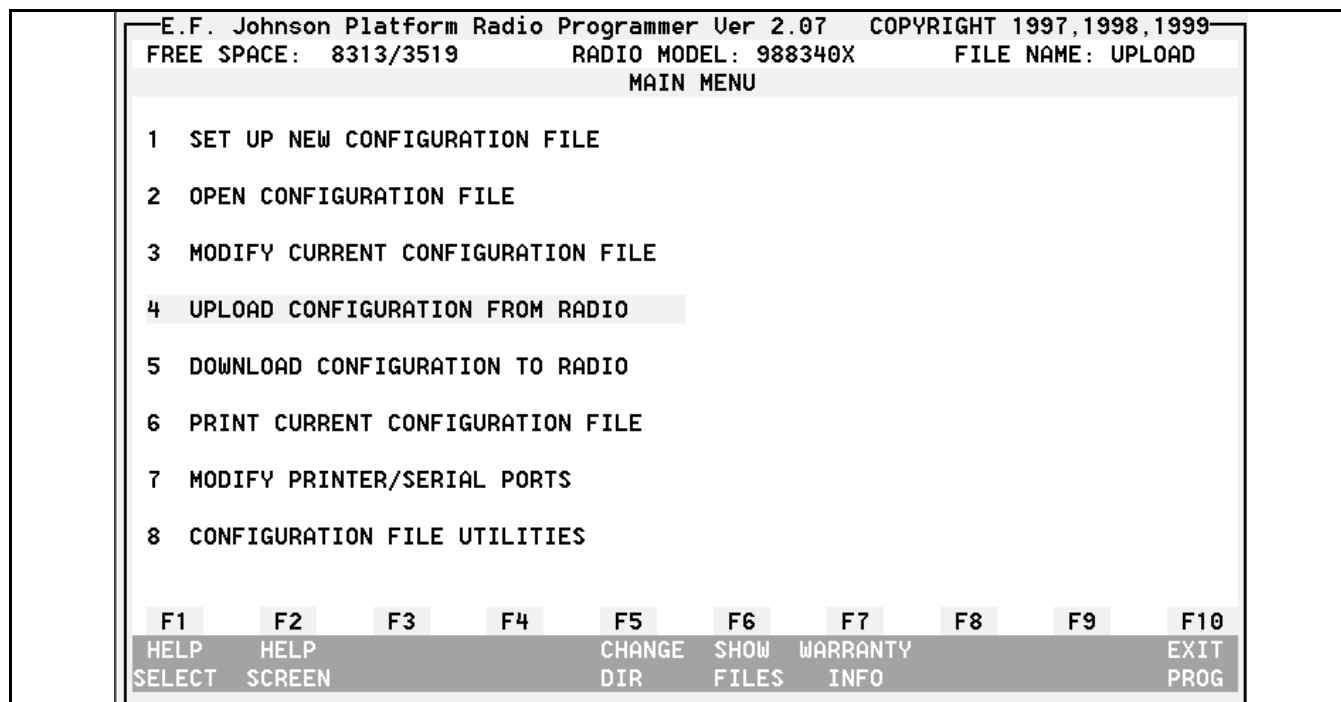

Figure 4-2 Main Menu

4. To display Group Table 2 for that system, press F7 and the screen in Table 4-4 is displayed. Program the parameters in this screen as described in this table.
5. When finished programming the group parameters, return to the “Modify Radio File” screen by pressing F9 or ESC. If creating another conventional system, repeat this section.

### Create/Edit/Delete Bank

One bank must be created with all models even if bank select is not available or not used. The “Modify Radio File” screen shown in Figure 4-3 should be on the screen. Proceed as follows:

1. To create a bank, select “Create Bank” and the screen in Table 4-2 is displayed. To edit an already created bank, select “Edit Bank”, and to delete a bank, select “Delete Bank”. With high-tier models which can have up to sixteen banks, another bank can be copied by selecting “Copy Bank”.
2. Program the information in this screen as described in Section 4.6.6 and Table 4-2.

### Linking Systems to the Bank

The programmed LTR and conventional systems must be linked to a bank to make them selectable. This also assigns the system number. Press F6 from the Create/Edit Bank screen and link the systems as described in Section 4.6.6.

### Linking Display Numbers to System/Groups (Low Tier Models Only)

With the low tier models, all programmed system/group combinations must be linked to a display number using the Channel Display screen shown in Figure 4-6. To display this screen, press the F7 key from the Create/Edit Bank screen. Refer to Section 4.6.6 for more information.

### Programming Transceiver

When all the programming described in the preceding sections is complete, the data is ready to be downloaded to the transceiver. Press F9 or ESC to return to the Main Menu in Figure 4-2. Select “Download Configuration File To Radio” and follow the on-screen prompts. The program performs error checking,

so if some fields are unprogrammed or improperly programmed, an error message is displayed. Refer to Section 4.5.6 for more information.

## 4.5 MAIN MENU

### 4.5.1 INTRODUCTION

The Main Menu screen shown in Figure 4-2 appears when the program is started. This screen is used to select the function to be performed. It determines if a new configuration file is to be created, an old file edited, or the current file is to be printed, saved or downloaded to a radio. It is also used to upload a file from a radio, and to copy, rename, or delete a disk file. The functions that can be selected in this screen are described in the following information.

The following function keys perform special functions in this menu. Other function keys active in this menu are described in the preceding section.

**F5 (Change Dir)** - Displays the screen that changes the current directory. When a configuration file is loaded from or saved to disk, it is always from or to the current directory. Therefore, if you need to change this directory, select this screen.

**F6 (Show Files)** - Displays the names of all radio configuration files that are in the current directory.

**F7 (Warranty Info)** - Displays the following screen which indicates the transceiver identification number described in Section 1.4. This number is stored in memory on the audio/logic board and cannot be changed. The “RF Power” parameter in this screen is the same as the “Type” number described in Section 1.4.

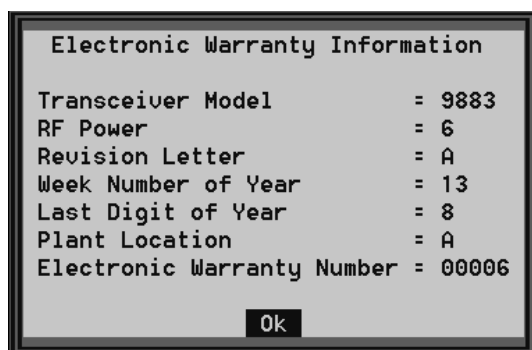

### 4.5.2 SET UP NEW CONFIGURATION FILE

This function is used to create a new configuration file. The type of radio is selected by specifying the following information. After this configuration information is selected, the Modify Radio File menu described in Section 4.6 is displayed.

**Radio Band** - 400, 800, or 900 MHz

**Radio Range** - 430-470 or 470-512 MHz

**Radio Type** - Low, Mid, or High Tier LTR

Low or High Tier LTR-Net upgradable

High Tier Multi-Net®

LTR or Multi-Net Data

**IF Bandwidth** - Dual (25 and 12.5 kHz),

Narrowband (12.5 kHz only)

The frequency range is displayed only with 400 MHz models because 800 and 900 MHz models are full band. Also, the IF bandwidth screen is not displayed with 900 MHz models because they are always narrow band. LTR transceivers which are LTR-Net upgradable have a “6” as the fifth digit of the part number (see next paragraph). The LTR-Net type must then be chosen to prevent a type error from occurring when the transceiver is programmed. LTR-Net operation is not actually programmed by this software.

The preceding information can be derived from the screen that is displayed by the F7 key (see Section 4.5.1). In addition, with high tier models, it can be derived from the transceiver part number that is briefly displayed when power is turned on (see Section 3.4.1). Refer to Sections 1.3 and 1.4 for more information on warranty and part numbers.

The radio type specified for a file can be changed using the Change Model/Band/Range/Tier parameter as described in Section 4.6.9. This allows, for example, one file to be used as a basis for programming another. This eliminates the need to re-enter some information when programming a similar transceiver.

### 4.5.3 OPEN CONFIGURATION FILE

This function is selected to open a configuration file stored on disk and load it into the computer memory. The files in the current directory are displayed and then the arrow and Return keys are used

to select the desired file. If the file is in another directory, press the Escape or F9 key and then F5 to change the current directory (see Section 4.5.1). After the file is opened, it can be edited, downloaded, printed, saved, copied, or renamed using the functions described in the next sections.

#### 4.5.4 MODIFY CURRENT CONFIGURATION FILE

This function is selected to edit the file currently residing in the computer memory. This file must have been previously loaded from disk as described in the preceding section or from a transceiver as described in the next section. If there is no file currently in memory, a message is displayed. This function displays the Modify Radio File menu described in Section 4.6. When the program is started, the last file edited is automatically loaded if it is in the current directory.

#### 4.5.5 UPLOAD CONFIGURATION FROM RADIO

##### General

This function is selected to copy (upload) a file stored in a transceiver into the computer memory. It can be used to check transceiver programming or use the data stored in one transceiver as a basis for programming another transceiver. The screen displayed by this function follows. Note that the tier and the software version number of the transceiver (see Section 3.12) are indicated in the lower left corner. See “Note” in the next section for information on a delay that may occur.



##### Upload Key

There is an eight-character “Upload Key” that can be programmed on the Main Radio Parameters screen (see Table 4-1). The purpose of this key is to prevent unauthorized uploading of information stored

in a transceiver. If any characters are entered in this field when the transceiver is programmed, the information in the transceiver cannot be uploaded unless the same characters are re-entered. It is recommended that only alphanumeric characters (numbers and letters) be entered. Case is not considered (“A” is the same as “a”). Leading spaces and spaces between characters are valid characters, but trailing spaces are ignored. Programming an upload key does not affect the ability to download (overwrite) data stored in a transceiver (see next section).

#### 4.5.6 DOWNLOAD CONFIGURATION TO RADIO

*NOTE: It is normal for the programming software to take up to 10 seconds to establish communication with the transceiver before sending or receiving data.*

This function is selected to program the transceiver with the configuration file that is currently in memory. Follow the instructions on the screen. If some data is incorrect or has not been entered, or if the radio type information specified is not the same as that stored in the transceiver (see Section 4.5.2), a message is displayed and the file is not downloaded. When programming is occurring, “PROG MODE” is displayed by the transceiver.

If an Upload Key is programmed (see preceding section), the information downloaded to the transceiver cannot be read back without entering the proper key. However, this does not affect the ability to download a file to the transceiver.

#### 4.5.7 PRINT CURRENT CONFIGURATION FILE

This function is selected to print the information in the current file. The computer port used for the printer can be selected as described in the next section. The file information can also be printed to a disk file instead of the printer. It is always printed to a file called PRINTOUT.PRN. Therefore, if there is already a file by that name in the current directory, it is overwritten.

#### 4.5.8 MODIFY PRINTER/SERIAL PORTS

This function is used to specify the computer port used by the printer and RPI (see Section 4.1.3). The printer can be connected to parallel port LPT1 or

LPT2, and the RPI can be connected to serial port COM1 or COM2. There is also an option to either save or not save the selected configuration for the next time that the program is run. The screen displayed by this function is shown below. Use the arrow keys and spacebar to display the desired configuration and then press Return with “Save Changes” highlighted to select that configuration.

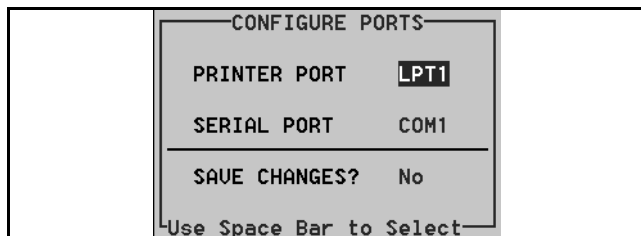

### 4.5.9 CONFIGURATION FILE UTILITIES

This function is selected to save, copy, rename, or delete a radio configuration file. The “Save” function saves the current configuration file to disk. This function should be used periodically while editing a file to ensure that all data is not lost if a power failure occurs or program execution is interrupted for some other reason.

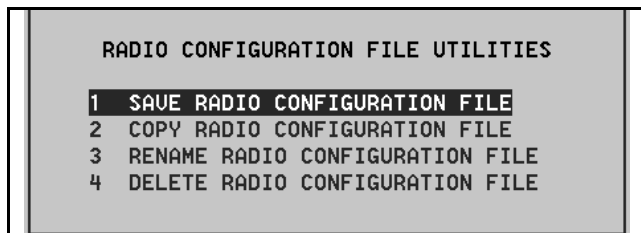

The copy, rename, and delete functions are performed on disk files. The files in the current directory are listed and then the arrow and Return keys are used to select the file. When copying a file, it must be given a new name and/or destination in the destination box. The screen displayed by this function follows.

## 4.6 MODIFY RADIO FILE MENU

### 4.6.1 INTRODUCTION

The Modify Radio File screen is used to select other screens which program the various types of configuration information. This screen is shown in Figure 4-3, and the screens it selects are described in the following information. The Main Menu “Set Up

New” and “Modify Current” configuration file functions described in Sections 4.5.2 and 4.5.4 select this screen. The following keys have special functions in this screen. Other special keys are described in Section 4.3.2.

**F5 (Show Banks)** - Displays the alpha tag of the banks programmed in the current file (see Section 4.6.6).

**F6 (Show Systems)** - Displays the alpha tag and type of all systems programmed in the current radio file. “L” = LTR and “C” = conventional.

### 4.6.2 EDIT MAIN RADIO PARAMETERS

#### General

This function selects the Main Radio Parameters screen which is used to program transceiver parameters that are the same for all systems. This screen and a description of each parameter it programs are described in Table 4-1. Parameters followed by “N/A” (not applicable) are not available with this transceiver.

#### I/O Options (F3)

Pressing F3 displays the I/O Interface Options screen. Refer to Section 4.9 for more information.

#### Channel Table (F6)

All channels to be assigned to LTR systems and conventional groups must be entered into a channel table. This table is displayed by pressing the F6 key from Main Radio Parameters menu (an example follows). With high tier models, up to three tables of channels can be programmed, so a menu is first displayed to select which table to program. The channel number assigned in this table is used to assign that channel in the system or group programming screen (FCC or programming channel numbers are not used). Up to 126 channels can be programmed in each table. Therefore, up to 126 different channels can be programmed with low tier models and up to 378 with high tier models.

The receive frequency is entered and then the transmit frequency is automatically displayed. With UHF and 800 MHz channels, the bandwidth (12.5 or 25 kHz) must also be entered. The 900 MHz channels are always 12.5 kHz. Conventional mode talk-around

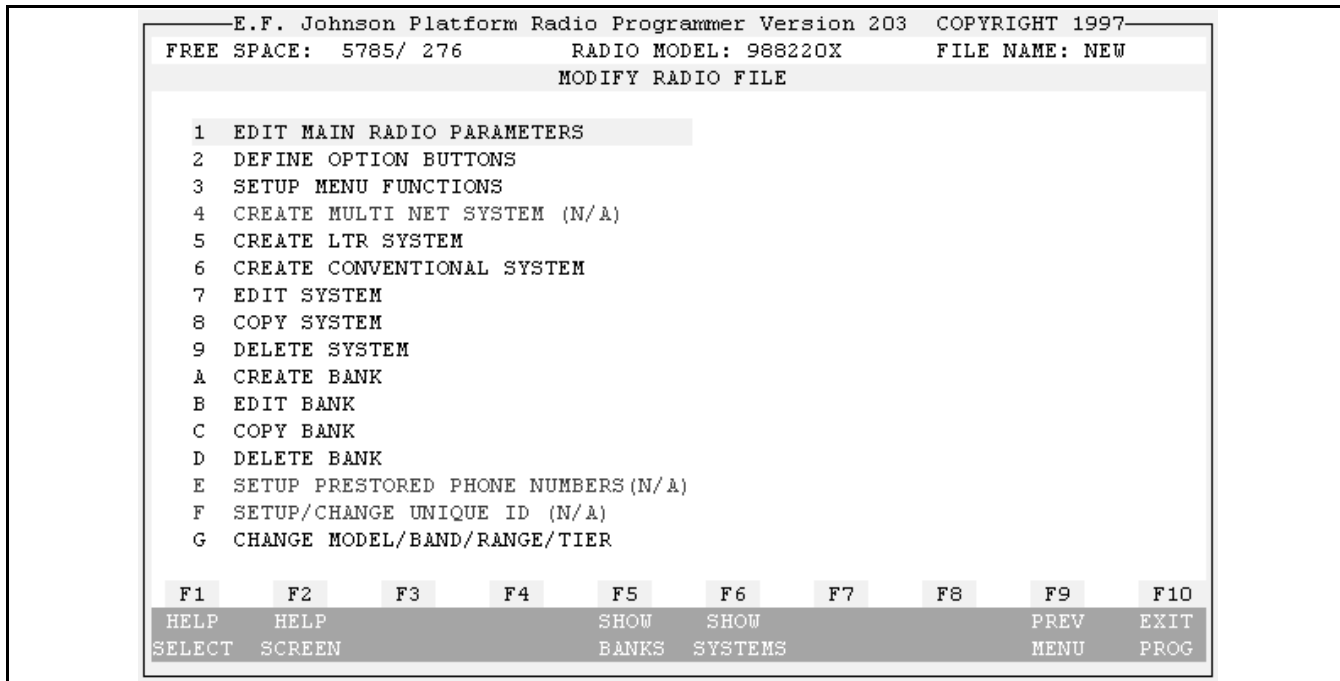

Figure 4-3 Modify Radio File Screen

is selected by group programming or the T/A option switch. Channels can be entered into this table and not assigned to a system or group if desired. The F5 and F6 keys are pressed to go to the previous or next page, respectively, and F8 clears all the channels on a page. With the UHF screen, the F3 or F4 key can be pressed to automatically enter a transmit frequency 5 MHz above or below the receive frequency.

Test Channel Table (F7)

The test channel table which follows (800 MHz version shown) is selected by pressing F7 to change the test channels used in the test mode described in Section 3.11. The sixteen default test channels shown in the tables in that section are programmed unless they are changed in this table. To return to the default frequency, enter “0” and it is reloaded the next time the table is displayed.

E.F. Johnson Platform Radio Programmer Version 204						
FREE SPACE: 10734/3598			RADIO MODEL: 984323X			
EDIT CHANNEL TABLE						
CHAN	I/F BW	RX FREQ	TX FREQ	CHAN	I/F BW	
1	12.5 KHz	470	470	17	12.5 KHz	
2	12.5 KHz	442	447	18	12.5 KHz	
3	12.5 KHz	454.125	459.125	19	12.5 KHz	
4	12.5 KHz	455.125	460.125	20	12.5 KHz	
5	12.5 KHz	451.125	456.125	21	12.5 KHz	
6	12.5 KHz	446	446	22	12.5 KHz	
7	12.5 KHz	461.0875	466.0875	23	12.5 KHz	
8	12.5 KHz	461.3625	466.3625	24	12.5 KHz	
9	12.5 KHz	461.6375	466.6375	25	12.5 KHz	
10	12.5 KHz	461.9375	466.9375	26	12.5 KHz	
11	12.5 KHz	462.2125	467.2125	27	12.5 KHz	
12	12.5 KHz	431	431	28	12.5 KHz	
13	12.5 KHz	432	432	29	12.5 KHz	
14	12.5 KHz	433	433	30	12.5 KHz	
15	12.5 KHz	434	434	31	12.5 KHz	
16	12.5 KHz	435	435	32	12.5 KHz	

F1	F2	F3	F4	F5	F6	F7
HELP	HELP	TX-	TX-	PREV	NEXT	
SELECT	SCREEN	RX+5	RX-5	PAGE	PAGE	

Use Space Bar to Select

Edit Channel Table (UHF Shown)

E.F. Johnson Platform Radio Programmer Version 204						
FREE SPACE: 5757/ 276			RADIO MODEL: 988220X			
EDIT TEST CHANNEL TABLE						
CHAN	I/F BW	RX FREQ	TX FREQ	CHAN	I/F BW	
1	N/A	851	806			
2	N/A	852	807			
3	N/A	853	808			
4	N/A	854	809			
5	N/A	855	810			
6	N/A	856	811			
7	N/A	857	812			
8	N/A	858	813			
9	N/A	860	815			
10	N/A	861	816			
11	N/A	863	818			
12	N/A	864	819			
13	N/A	865	820			
14	N/A	867	822			
15	N/A	868	823			
16	N/A	870	825			

F1	F2	F3	F4	F5	F6	F7
HELP	HELP					
SELECT	SCREEN					

Enter receive freq (in MHz)

Edit Test Channel Table (800 MHz Shown)

### 4.6.3 DEFINE OPTION BUTTONS

The Define Option Buttons screen shown in Figure 4-4 programs the option buttons on the front panel of the transceiver. With low tier models, the AUX1 and AUX2 buttons are programmable, and with high tier models, all five buttons are programmable. Any button can also be disabled if desired.

The arrow keys select the button to be programmed and the Return key is pressed to move to the box on the right which lists the available choices for that button. Use the arrow keys to move the highlight block to the desired choice and select that choice by pressing the Return key. To exit a key without making any changes, press Escape. Refer to Section 3.5.1 for more information on the auxiliary switches.

### 4.6.4 SETUP MENU FUNCTIONS

The Setup Menu screen shown in Figure 4-5 is used to select which menu items can be selected by the user in the menu mode (available with high tier only). In addition, with all models, it is used to set the default condition of parameters not controlled by the menu mode or an option switch. If a function is programmed for an option switch, it cannot be programmed as a menu item and vice versa.

If an item is programmed as not selectable (Include = No) or is not available (Include = N/A), it is fixed in the condition displayed in the Default column. For example, if Tones = No or N/A and Default = All Tone, the TONES menu parameter is not selectable (if applicable) and all tones always sound.

If a menu item is selectable by the menu mode or an option switch, the default condition exists only until that function is changed (or changes automatically as can occur with the horn alert). The last selected and not the default condition is selected when power is turned on. Use the arrow keys and spacebar to select the desired parameter in each column. Refer to Section 3.6 for more Menu Mode information.

### 4.6.5 CREATE/EDIT/COPY/DELETE SYSTEM

*NOTE: At least one bank must always be programmed even if bank select is not used or not available. All systems to be selected must then be linked to a bank as described later in this section.*

### Programming System/Groups With Low Tier Models

With the low-tier models, up to 16 system/group combinations can be programmed. These 16 combinations are then assigned to display channel numbers by the Channel Display table (see Figure 4-6). This table is selected by pressing F7 in the Create/Edit Bank screen (see Section 4.6.6). All programmed systems and groups should be assigned to a display number in this table. If some systems are not assigned, be sure they are not linked to a bank. Likewise, if some groups in an assigned system are unassigned, they must be programmed "ASN = No".

#### Create System

The Create System functions are used to create new LTR or conventional systems. Up to sixteen systems can be created with low tier models, and up to 100 systems can be created with high tier models (see Section 1.2.3).

The alpha tag for the new system is entered (up to eight characters) and then the Create/Edit System screen is displayed. With low tier models, the system alpha tag is used for programming only, and is not displayed by the transceiver. With high tier models, it is displayed if the alpha tag display mode is selected (see Section 3.4.4).

#### Edit System

The Edit System function is used to program the current system parameters. The system to be edited is selected from a list of the current systems that is displayed. The arrow and Return keys are used to select the desired system. "L" indicates an LTR system, and "C" indicates a conventional system. The LTR and conventional screens and parameter descriptions are shown in the following tables:

#### **LTR Systems and Groups - Table 4-3**

#### **Conventional Systems and Groups - Table 4-4**

*NOTE: The channel numbers entered in the LTR and conventional screens are from the channel table that is programmed by pressing F6 in the Main Radio Parameters screen. FCC channel numbers are not used. Refer to Section 4.7.2 for more information.*

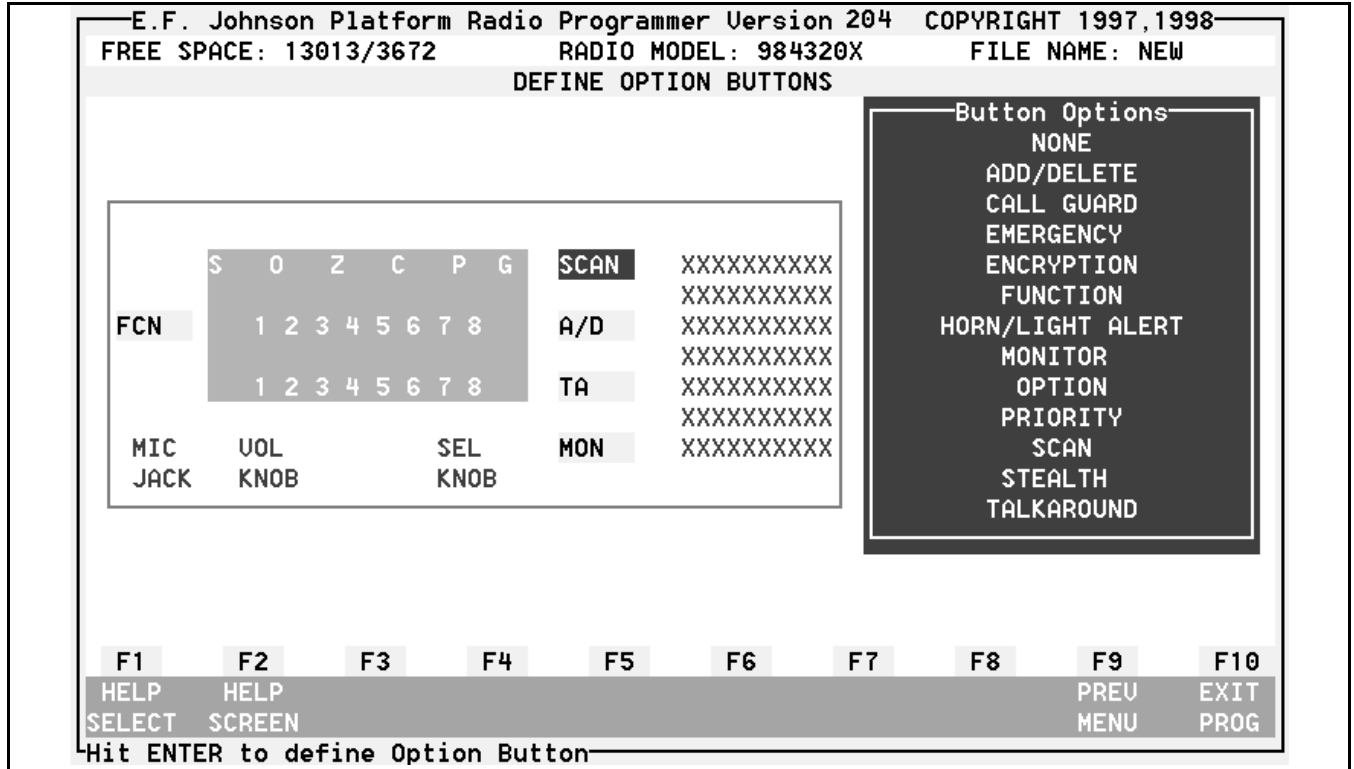

Figure 4-4 Define Option Buttons Screen (High Tier Shown)

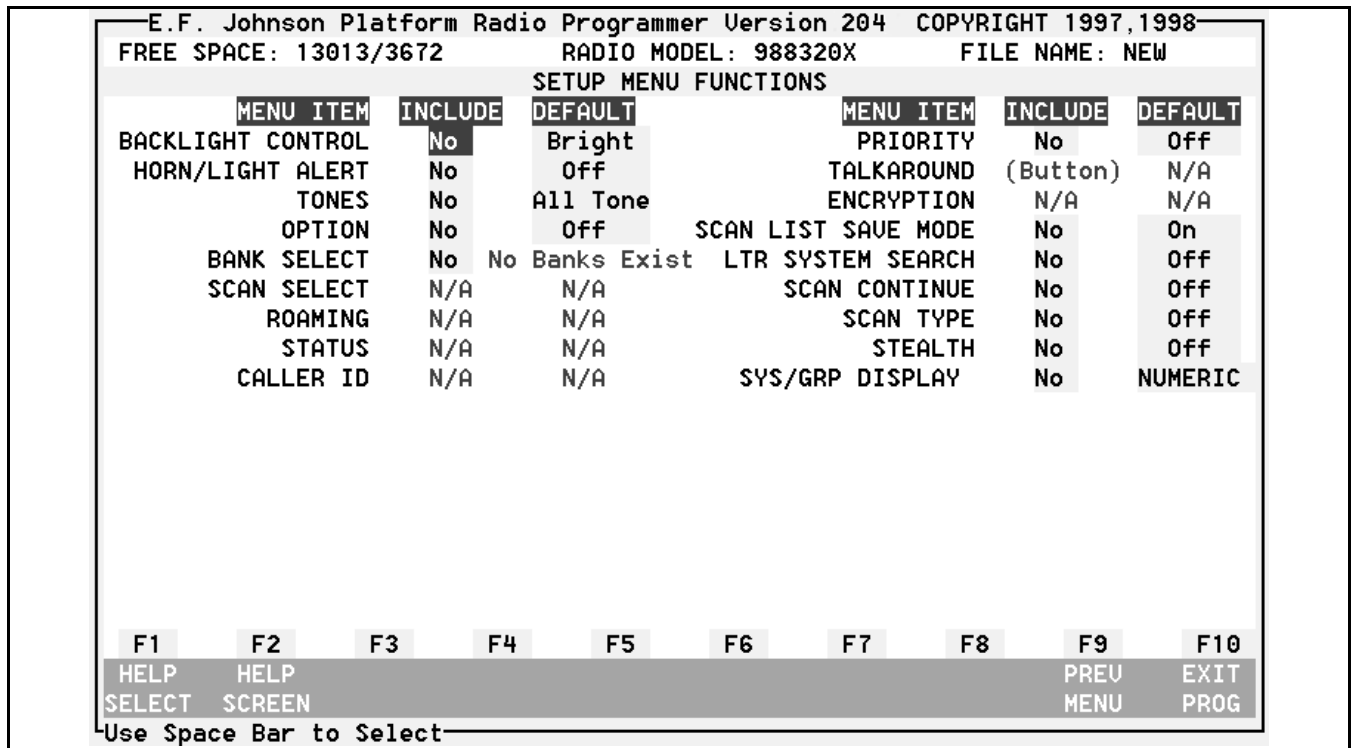

Figure 4-5 Setup Menu Functions Screen (High Tier Shown)



The following function keys are used in the Create/Edit System screen to perform special functions:

**F3 (Lookup Freq)** - This key displays the applicable channel table when programming a channel number. With the channel table displayed, the cursor can then be moved to the desired channel and F7 (Select Freq) pressed to redisplay the screen and enter the highlighted channel number.

**F4 (Edit Channels)** - Moves the cursor to the channel table at the bottom of the screen (LTR only).

**F5 - (Edit System)** - Moves the cursor to the system information table at the top of the screen (LTR only).

**F6 (Setup Groups)** - Displays the group programming screens shown in Tables 4-3 (LTR) and 4-4 (conventional).

**F7 (Group Options)** - With conventional systems only, displays the second Group Options screen shown in Table 4-4 (two screens are required to program all the conventional group parameters). Changing the Assign (ASN) or alpha tag in one screen also changes it in the other.

**F8 (A/D Bank)** - Each system must be linked to a bank. Refer to Section 4.6.6 for more information.

### Copy System

This screen is used to create a new system by copying information from another. The system to be copied is selected from a list and then the alpha tag for the new system is entered. This function does not copy anything to a disk file; it only copies to a new system in the buffer.

### Delete System

This screen is used to delete a current system. The system to be deleted is selected from a list. This function does not delete anything on disk; it only deletes the selected system in the buffer.

## 4.6.6 CREATE/EDIT/DELETE BANK

### Introduction

Although only high tier models have a bank select feature, at least one bank must be created with all models (see Section 3.5.2). The programmed systems must then be assigned a bank. If a programmed system is not linked to a bank, it is not selectable and cannot be scanned.

The process of linking a system to a bank also assigns the system number that is used to program the low tier Channel Display table (see description which follows) or is displayed when a high tier system is selected. Therefore, first create a bank and then link the programmed systems to that bank. More information follows.

### Create Bank

The Create Bank function is used to create a new bank. As previously stated, at least one bank always must be created. Banks are identified by an alpha tag which can have up to eight characters. With low tier models, if a bank already exists, another cannot be created until the current bank is deleted (see “Delete Bank” which follows).

After the bank alpha tag is entered, the Create/Edit Bank screen is displayed. This screen is used to edit information unique to a bank. This screen and the parameters it programs are described in Table 4-2.

### Edit Bank

The Edit Bank function is used to change parameters of the previously created bank. The bank to be edited is selected and the Create/Edit Bank screen is then displayed (see preceding “Create Bank” description).

### Copy Bank

With high tier models which can have more than one bank, this screen is used to create a new bank by copying information from another bank.

Delete Bank

This function is used to delete the current bank. The bank to be deleted is selected and it is then deleted. This also unassigns all systems currently linked to that bank. This does not delete anything on disk; only the selected bank in the buffer is deleted.

Linking Systems To A Bank

Systems are created using the Create System or Copy System functions as described in Section 4.6.5. The programmed systems must then be linked to a bank. This can be done from the System programming screens described in Section 4.6.5 or from the Create/Edit Bank screen described in this section.

When systems are created, they are identified by alpha tags, and numbers are not assigned until they are linked to a bank. To link a system to a bank, proceed as follows:

1. When system information is being programmed, the bank name is displayed on the right side of the screen by pressing F8. Likewise, when bank information is being programmed, the system numbers are indicated (see Table 4-2). If the system is assigned to the bank, there is a system number to the right of the name. If it is not assigned, "XX" is indicated.
2. To add or delete the current system, press the F8 key and then use the arrow keys to highlight the desired system (if applicable). To add the system to the bank, press the "A" key, and to delete it press the "D" key.
3. If a system was added, the highlight bar moves to the system number column. This column programs the number of that system. Enter the desired number from 1-99. Press the Return key once to make the change and press it again to go back to editing system or bank information.

Channel Display Table (Low Tier Models)

With low tier models only, pressing the F7 key from the Create/Edit Bank screen displays the Channel Display Table screen shown in Figure 4-6. This screen

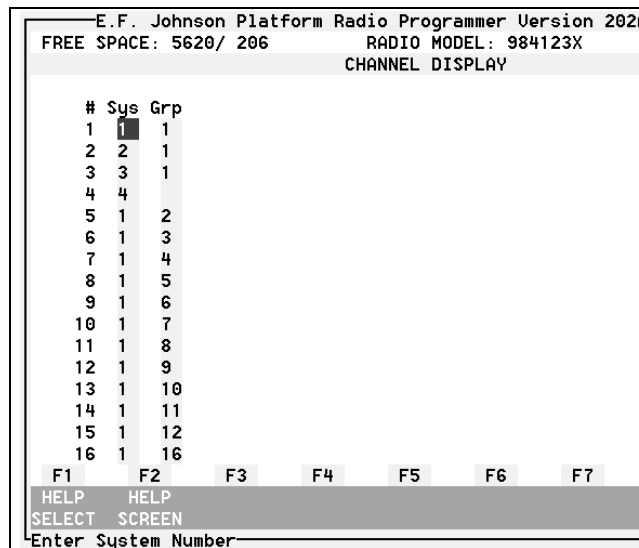

**Figure 4-6 Channel Display Screen (Low Tier Only)**

assigns the system/group selected by each display number. Up to sixteen system/group combinations can be selected. If a number is left unprogrammed, it is not displayed.

The system number is assigned when the system is linked to the bank as described in the preceding information. Any combination of up to 16 systems with up to 16 groups each that have been previously programmed can be assigned. All programmed systems and groups should be assigned to a display number. Refer to "Programming System/Groups With Low Tier Models" in Section 4.6.5 for more information.

Functions such as scanning are more efficient if system information does not need to be loaded to scan each position. Therefore, if the system information is the same for several groups, assign the groups to the same system, not several identical systems. For example, to program three groups with the same system information, program them as System 1, Groups 1, 2, and 3; not System 1/Group 1, System 2/Group 1, and System 3/Group1.

**4.6.7 SETUP PRESTORED NUMBERS**

This function is not available with 98xx transceivers. It is used to program prestored telephone numbers.

#### 4.6.8 SETUP/CHANGE UNIQUE ID

This function is not available with LTR 98xx transceivers. It is used to program the unique ID in Multi-Net models.

#### 4.6.9 CHANGE MODEL/BAND/RANGE/TIER

This function allows a file programmed for one type of transceiver to be converted for use as a basis for programming another type. Any parameters that may no longer be valid such as bandwidth or channel frequencies are automatically changed to valid values.

### 4.7 ADDITIONAL PROGRAMMING INFORMATION

#### 4.7.1 REPEATER NUMBER PROGRAMMING

Each LTR repeater site can have up to 20 repeaters. The repeaters at the same site are assigned a unique number from 1-20. Although these numbers can be assigned arbitrarily, for maximum system efficiency a scheme should be used which equalizes, as much as possible, the gaps between numbers. For example, a five-repeater system should use numbers 1, 5, 9, 13, and 17. The number assigned to a repeater is programmed in the repeater and the mobiles assigned to that home repeater.

#### 4.7.2 CHANNEL NUMBER PROGRAMMING

##### NOTES:

*FCC channel numbers are not used to program this transceiver.*

*Never program transmit frequencies in the 406-406.1 band which is reserved for distress beacons.*

The channel numbers used to program this transceiver come from the channel table. This table is programmed by pressing the F6 key in the Main Radio Parameters screen described in Section 4.6.2 and then entering frequencies for the desired channels. Each table is four pages long and can be programmed with up to 126 channels. Other pages are displayed by pressing the F5 and F6 keys.

With low tier models, one channel table can be programmed, and with high tier models up to three tables (378 channels) can be programmed. The channels assigned to a system must come from the same table. Therefore, with high tier models, the channel table used by the system is one of the programmable system parameters. The 12.5/25 kHz IF bandwidth parameter applies to only 800 MHz channels because 900 channels are always 12.5 kHz.

#### 4.7.3 SPECIFYING RIC-EQUIPPED REPEATERS

When programming the channel numbers of LTR and conventional systems, you can specify if the repeater is equipped with an EFJohnson repeater interconnect (RIC) or telephone interconnect (TIC) controller. If a system with a transmit ID code programmed for interconnect is then selected, the transceiver will attempt to access only repeaters specified as equipped with this controller. This allows both interconnect and non-interconnect repeaters to be programmed in each selectable system.

Without this feature, the transceiver may trunk to a repeater not equipped with an interconnect controller when a telephone call is made. No dial tone or other supervision is then returned when the PTT switch is released which may be confusing to the user.

### 4.8 UPDATING RADIO SOFTWARE

#### 4.8.1 INTRODUCTION

The transceiver operating software (firmware) can be updated in the field without replacing the microcontroller or a memory device such as an EPROM. For example, the radio software may be updated to correct software bugs or add feature enhancements. This is made possible by the use of a reprogrammable Flash memory device (see Section 1.2.7).

The same basic hardware used to program personality information is also used to update radio software. One difference may be the Remote Programming Interface (RPI). To update the radio software, RPI, Part No. 023-9800-000, is required. Earlier RPI's such as the 023-9750-000 or 023-5810-000 do not work.

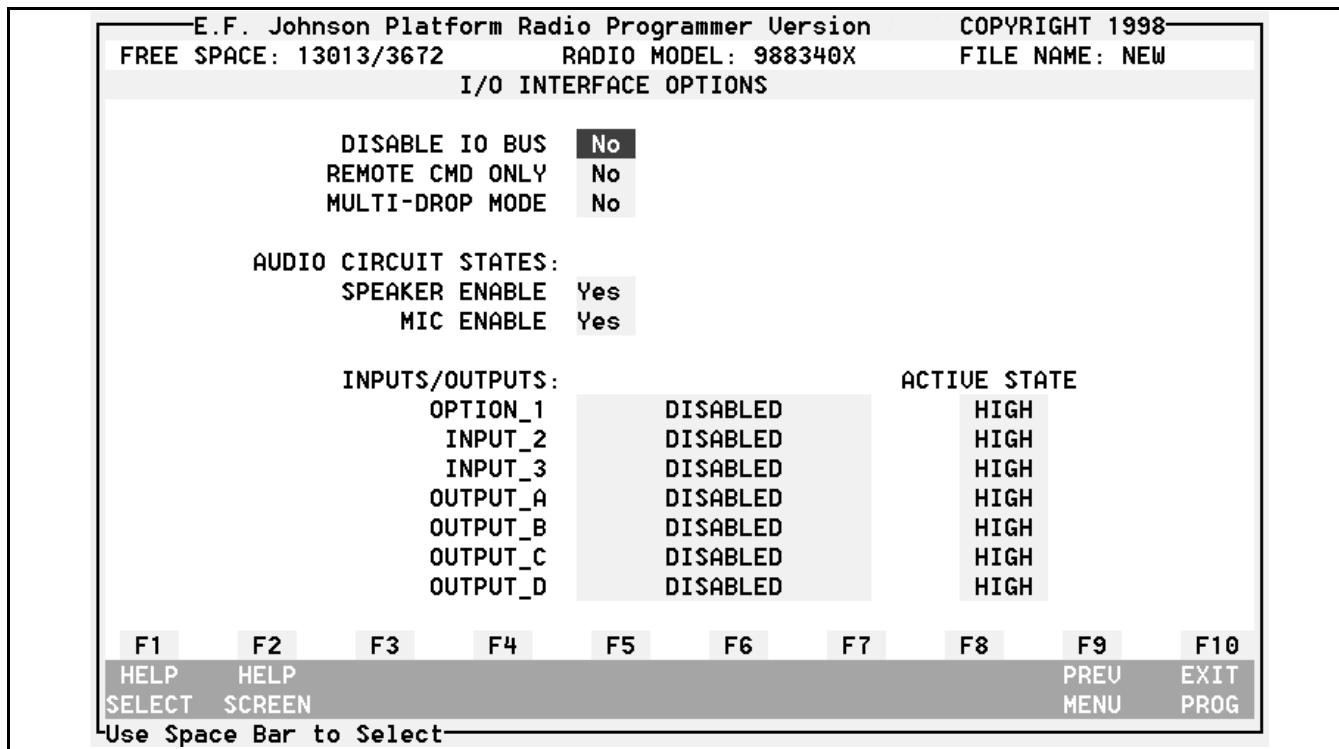

Figure 4-7 I/O Interface Options Screen

Programming is performed using separate Flash programming software (see Table 1-3). This program is run by typing PLATUPD at the DOS prompt (the DOS mode must usually be used). The program requires a special data file which contains the updated radio software (see next section). Follow the instructions on the screen to perform the actual updating.

#### 4.8.2 DATA FILE

To update the radio software, the data file containing the new radio software is required. The filename of this data file is 98xtsXzz.S19. The “t” is the type number and “s” the signaling type from the transceiver part number (7th and 8th digits, respectively, as described in Section 1.3). The “zz” characters indicate the feature level of the software in the file.

Contact your Customer Service or your sales representative concerning the availability of software updates for this transceiver. They may be available on the EFJohnson ACES® Bulletin Board System for downloading. To access this system, dial toll-free from the U.S. and Canada 1-800-227-3997 (N, 8, 1, ANSI). From other countries, dial 507-835-8607.

If you do not know your login ID or have questions or would like to sign up for service on this system, call 1-800-328-3911, extension 7 (USA and Canada) or 507-835-6222, extension 2100 (international). Once the data file is obtained, it must be copied to the directory containing the program. Refer to Section 4.2.3 for information on how to copy files.

### 4.9 I/O LINE PROGRAMMING

#### 4.9.1 INTRODUCTION

The audio/logic board has several input/output lines that can be used for operation with an external data modem or other devices such as compandor and encryption modules. These lines are brought out of the transceiver by cables connected to J301 and/or J101 (see Sections 2.4 and 2.7). In addition, several are accessed at the Option Slot 1 and 2 wire-outs.

Some of these lines can be programmed for various functions as described in Section 4.9.4 and others have fixed functions. Refer to Appendix A for a complete description of input/output line functions.

## 4.9.2 TRANSCEIVER AND PROGRAMMING SOFTWARE REQUIRED

The input/output and serial bus functions are available only in transceivers with software Version 205 or later. The software version can be determined as described in Section 3.12.

To program these input/output lines, programming software Version 204 or later is required. The software version number is displayed on the top of most programming screens.

## 4.9.3 PROGRAMMING FOR OPTIONS

The following accessories utilize programmable I/O lines. Therefore, if any are installed, the particular input and/or output line used must also be programmed for that function.

- Comandor Module (Section 3.5.4)
- Encryption Module (Section 3.5.7)
- External Encoder/Decoder (Section 3.9.7)

For example, if a comandor module is installed in Option Slot 2 and controlled by Output B, that I/O line must be programmed for “Comand”. This programming is performed in the Inputs/Outputs section of the I/O screen in Figure 4-7. This is in addition to system or group programming for that function if applicable. The only time I/O programming is not required is if the transceiver has early software that does not support I/O bus programming (Version 204 or earlier). Only system or group programming is then required.

## 4.9.4 PROGRAMMING I/O INTERFACE OPTIONS

The screen used to program the I/O lines is shown in Figure 4-7, and it is displayed by pressing F3 from the Main Radio Parameters screen described in Section 4.6.2. The screen in Figure 4-7 shows the default condition of the various parameters. More information on these parameters follows:

**Disable IO Bus** - This function applies to high tier models only. Programming “Yes” disables all the input/output lines shown on the bottom of the screen and also the serial bus commands. This can be used to prevent unauthorized access through the serial bus to information stored in the transceiver. The other part of this protection is the “Upload Key” described in Section 4.5.5 which prevents unauthorized uploading of information using the programming software.

**Remote CMD Only** - Sets up the serial bus for operation with an intelligent remote control unit. The standard configuration programmed by “No” allows the use of a local control panel, with most functions being controlled by the transceiver. The remote configuration programmed by “Yes” allows an intelligent remote control unit or computer to control most transceiver functions. The transceiver control logic functions mostly as an interface with the external device.

**Multi-Drop Mode** - Programming “Yes” configures the serial bus so that several control units can be connected to the transceiver in a multi-drop configuration. The TxD and RxD lines are tied together in this mode. In addition, the Option 1 line is forced to be the multi-drop bus Busy line (see MD BUS BUSY in Appendix A.3.3).

*NOTE: To perform reprogramming once the Multi-Drop Mode is selected, the TxD and RxD lines must be disconnected and the transceiver powered up in the test mode.*

**Speaker Enable** - Programming “No” closes audio gate U307C (mutes the audio) and allows it to be opened only by the proper remote (serial) command.

**Mic Enable** - Programming “No” closes transmit audio gate U308B (mutes microphone signal) and allows it to be opened only by the proper remote (serial) command.

**Inputs/Outputs** - Programs the configuration of the various input and output lines. Both the function and active state can be programmed for each. Refer to Appendix A for a complete description of these lines and the functions that are available for each.

NOTE: Refer to Section 4.6.2 for more information on programming the parameters in the following table.

Table 4-1 Main Radio Parameters Screen

E.F. Johnson Platform Radio Programmer Version 204 COPYRIGHT 1998									
FREE SPACE: 13013/3672			RADIO MODEL: 984320X			FILE NAME: NEW			
MAIN RADIO PARAMETERS									
RECEIVE DELAY TIME	4 secs	STATUS DEFINITIONS							
CALL DELAY TIME	4 secs	1 :	N/A						
SCAN CONTINUE TIME	0 secs	2 :	N/A						
SCAN REVERT MODE	Last Selected	3 :	N/A						
IGNITION SENSE DELAY TIME	Immediate	4 :	N/A						
CONV PROCEED TO TALK TONE	Enabled	5 :	N/A						
PROCEED TO TALK TONE TYPE	STD	6 :	N/A						
TRANSMIT TIME OUT TIME	30 sec	7 :	N/A						
MIC HANGER	Enabled	8 :	N/A						
DISPLAY EMERGENCY	Yes	DIGITAL VOLUME 20							
PRIORITY 1 SAMPLING TIME	1 sec								
SELECT KNOB DEFAULT	SYSTEMS								
SELECT KNOB RETURN TIME	0 secs	UPLOAD KEY							
RADIO HAS ENCRYPTION INSTALLED	No	PENALTY TOT 0 secs							
HORN HONK MODE	Mode A	HONK COUNT 3							
RADIO CAN BE DISABLED (MN ONLY)	N/A	HONK ON TIME 500 msec							
RADIO CAN BE INTERROGATED (MN ONLY)	N/A	HONK OFF TIME 500 msec							
F1	F2	F3	F4	F5	F6	F7	F8	F9	F10
HELP	HELP	IO	CHAN			TEST	PREV		EXIT
SELECT	SCREEN	OPTION	TABLE			TABLE	MENU		PROG
Use Space Bar to Select									

Parameter	Available Responses	Description
Receive Delay Time	0, 1, 2, 3, 4, 5, 6, or 7 seconds	Time before scanning resumes after a message is received (Section 3.7.3).
Call Delay Time	0, 1, 2, 3, 4, 5, 6, or 7 seconds	Time before scanning resumes after message is transmitted (Section 3.7.3).
Scan Continue Time	0-60 seconds	Maximum time that a call is monitored before scanning resumes (Section 3.7.3).
Scan Revert Mode	Last Selected, Temporary, Last Received	Selects the system/group that is selected when the transmitter is keyed in the scan mode or the scan mode is exited (Section 3.7.4).
Ignition Sense Delay Time	Immediate, 10, 20, 30, 40, 50 minutes, 1, 2, 4, 8, 10, 12, 16 hours, Forever	Selects the power turn-off delay. If the ignition sense input is not used, always select "Forever" (Sections 2.4 and 3.5.12).
Conv Proceed to Talk Tone	Disabled, Enabled	Enables or disables the proceed-to-talk tone on conventional systems. It is always enabled on LTR systems if tones are enabled (Section 3.5.13).
Proceed Tone Type	Standard, Loud	Selects if a standard or loud proceed tone sounds (Section 3.5.13).
Transmit Time-Out Time	0.5-5 minutes in 0.5-minute steps, Off	Programs the Time-Out Timer (Section 3.5.16). See also penalty TOT which follows.
Mic Hanger	Enabled, Disabled	When "Disabled" is programmed, taking the microphone off-hook does not enable the monitor mode or disable system and group scanning.
Display Emergency (high tier only)	Yes, No	When "No" is programmed, the display does not indicate "EMERGENCY" when the Emergency switch is pressed (Section 3.5.6).

**Table 4-1 Main Radio Parameters Screen (Continued)**

<b>Parameter</b>	<b>Available Responses</b>	<b>Description</b>
Priority 1 Sampling Time	Disabled, 500 ms, 1 or 2 seconds	Selects how often the Priority 1 system/group (if programmed) is sampled on conventional systems (Section 3.9.6).
Select Knob Default (high tier only)	Systems or Groups	Programs if the system or group select mode is enabled when power is turned on or the return time expires (see next parameter).
Select Knob Return Time (high tier only)	0-15 seconds in 1-second steps	Programs the delay after a change is made before the arrow/underline again indicates the default display mode programmed above. "0" programs no return (Section 3.4.5).
Radio Has Encryption Installed	Yes, No	"Yes" is programmed if encryption is installed (Section 3.5.7).
Horn Honk Mode	Mode A or Mode B	Programs the horn alert operating mode (Section 3.5.10).
Radio Can Be Disabled	N/A	This feature is not available with LTR models of this transceiver.
Radio Can Be Interrogated	N/A	This feature is not available with LTR models of this transceiver.
Status Definitions	N/A	Status messaging is not available with LTR models of this transceiver.
Digital Volume	0-63	Sets the volume level of data transceivers which do not have an external volume control. In addition, with low tier models, it sets the initial volume setting that is selected after programming. "0" selects minimum and "63" maximum ("20" is default). This is not used with high tier models because they use an analog volume control to set the volume.
Upload Key	Up to eight alphanumeric characters	If one or more characters are entered, information programmed into the transceiver cannot be uploaded unless the same characters are re-entered. If this is left blank, no upload lock is used (see Section 4.5.5).
Penalty TOT	0-60 seconds in 1-second steps	Programs how long transmitting is inhibited after the time-out timer disables the transmitter (Section 3.5.16).
Honk Count (high tier only)	1-8	Programs the number of times the horn alert sounds when it is enabled. This parameter is fixed at "3" with low tier models (Section 3.5.10).
Horn On/Off Time (high tier only)	250, 500, 750 ms, 1 sec	Programs the on and off times of each horn alert cycle (count). Each time can be different. With low tier models, the on and off times are both fixed at 500 ms (Section 3.5.10).

NOTE: Refer to Section 4.6.6 for more information on programming the parameters in the following table.

**Table 4-2 Create/Edit Bank Parameters Screen**

```

E.F. Johnson Platform Radio Programmer Version 202  COPYRIGHT 1997
FREE SPACE: 5620/ 206          RADIO MODEL: 984123X          FILE NAME: PERL0825
CREATE/EDIT BANK
ALPHA TAG  BANK1
NUMBER OF SYSTEMS IN BANK  7
OPTIONAL FIELDS
SCAN SELECT(MN ONLY)  N/A
WIDE AREA GROUP TRACKING(MN ONLY)  N/A
INHIBIT TRANSMIT DURING BLOCK DECODE  No

TYPE  SYSTEM  GROUP
HOME  3        1
PRIORITY 1  FIXED  2        1
PRIORITY 2  SELECTED
FIXED TX DURING SCAN DATA
EMERGENCY  N/A    N/A    N/A

CURRENT SYSTEMS
C1W  01  C
C2W  02  C
JH01W  03  L
LSL01W  04  L
LJS01W  05  L
C1N  11  C
C2N  12  C

F1  F2  F3  F4  F5  F6  F7  F8  F9  F10
HELP  HELP  A/D  CHAN  PREU  EXIT
SELECT  SCREEN  SYSTEMS  DISP  MENU  PROG
Enter Home System Number
    
```

Parameter	Available Responses	Description
Alpha Tag	Up to eight alphanumeric characters	Changes the alpha tag for the selected bank. With low tier models, this is used only for bank identification during programming because banks are not selectable or displayed. With high tier models, it is displayed when selecting banks if multiple bank selection is programmed (Section 3.5.2).
Number of Systems in Bank	1-16	The number of systems that have been assigned to that bank. Systems are assigned by pressing F6 (see Section 4.6.6).
Inhibit Transmit During Block Decode	Yes, No	“Yes” disables the transmitter while a call is being received on a block ID (see Section 3.8.3).
<b>OPTIONAL FIELDS</b>		
Scan Select	N/A	This feature does not apply to LTR versions of this transceiver.
Wide Area Group Tracking	N/A	This feature does not apply to LTR versions of this transceiver.
Home System/ Group	Any selectable system/group assigned to bank	Programs the system/group that is selected by the Home select feature (Section 3.5.9). With low tier models, a selectable system/group must be entered.
Priority 1 System/ Group	<b>Type</b> = Disabled, Selected, Fixed <b>System/Group</b> = The number of any selectable conventional system/group in the bank	If priority group sampling is used on conventional systems, programs the Priority 1 system/group. “Selected” = The priority sys/grp is always the one selected by the transceiver. “Fixed” = The priority system/group is always the one programmed on this screen. “Disabled” = No priority system/group is programmed (Section 3.9.6).
Priority 2 System/ Group	Same as for priority 1 above	If Priority 1 above is “Disabled”, Priority 2 sampling is not available. Also, either Priority 1 or 2 can be “Selected”, but not both (Section 3.9.6).



**Table 4-2 Create/Edit Bank Parameters Screen (Continued)**

Parameter	Available Responses	Description
Fixed System/ Group Transmit During Scan	Any system/group assigned to the bank	If a system/group is entered, it takes precedence over the Scan Revert Mode programming on the Main Radio Parameters screen if the transmitter is keyed while scanning is occurring (Section 3.7.5).
Data System/Group	Any system/group in the bank	Programs the default system/group that is selected for a data transmission if the selected group is not programmed for data (Section 3.5.5).
Emergency System/ Group (high tier only)	<b>Type</b> = always "fixed" with LTR models <b>System/Group</b> = System alpha tag/group number	Programs the emergency system/group that is selected if no emergency system/group is programmed for the currently selected system. The Tab/shift Tab keys are used to select/deselect the system from those in the bank (Section 3.5.6).

NOTE: Refer to Section 4.6.5 for more information on programming the parameters in the following table.

**Table 4-3 LTR System Parameters**

<p>E.F. Johnson Platform Radio Programmer Version 203 COPYRIGHT 1997                  FREE SPACE: 3658/ 239 RADIO MODEL: 988220X FILE NAME: NEW                  CREATE/EDIT LTR SYSTEM</p>																																																																																	
<p>ALPHA TAG JHO1W HOME 1 AREA 0 GROUP CALL                  REPEATER INTERCONNECT START 200 STOP 250 DECODE LIGHT HORN ENCRYPT                  TX INHIBIT ID START 0 STOP 0 PRIORITY 1 2 No No N/A                  BLOCK DECODE START 100 STOP 101 PRIORITY 2 3 Yes No N/A                  POWER LEVEL LOW                  BUSY QUEUE Yes CHANNEL TABLE NUMBER 1                  GROUP SCAN Enabled                  SCAN LIST Yes SYSTEM GROUP AUTOMATIC                  COMPANDING No EMERGENCY N/A N/A N/A</p>																																																																																	
<p>REPEATER CHANNEL TABLE</p> <table border="1"> <thead> <tr> <th>NO</th> <th>CHN</th> <th>RIC</th> <th>NO</th> <th>CHN</th> <th>RIC</th> <th>NO</th> <th>CHN</th> <th>RIC</th> <th>NO</th> <th>CHN</th> <th>RIC</th> </tr> </thead> <tbody> <tr> <td>1</td> <td>7</td> <td>Yes</td> <td>2</td> <td>0</td> <td>No</td> <td>3</td> <td>0</td> <td>No</td> <td>4</td> <td>0</td> <td>No</td> </tr> <tr> <td>5</td> <td>8</td> <td>No</td> <td>6</td> <td>0</td> <td>No</td> <td>7</td> <td>0</td> <td>No</td> <td>8</td> <td>0</td> <td>No</td> </tr> <tr> <td>9</td> <td>0</td> <td>No</td> <td>10</td> <td>0</td> <td>No</td> <td>11</td> <td>0</td> <td>No</td> <td>12</td> <td>0</td> <td>No</td> </tr> <tr> <td>13</td> <td>0</td> <td>No</td> <td>14</td> <td>0</td> <td>No</td> <td>15</td> <td>0</td> <td>No</td> <td>16</td> <td>0</td> <td>No</td> </tr> <tr> <td>17</td> <td>0</td> <td>No</td> <td>18</td> <td>0</td> <td>No</td> <td>19</td> <td>0</td> <td>No</td> <td>20</td> <td>0</td> <td>No</td> </tr> </tbody> </table>										NO	CHN	RIC	NO	CHN	RIC	NO	CHN	RIC	NO	CHN	RIC	1	7	Yes	2	0	No	3	0	No	4	0	No	5	8	No	6	0	No	7	0	No	8	0	No	9	0	No	10	0	No	11	0	No	12	0	No	13	0	No	14	0	No	15	0	No	16	0	No	17	0	No	18	0	No	19	0	No	20	0	No
NO	CHN	RIC	NO	CHN	RIC	NO	CHN	RIC	NO	CHN	RIC																																																																						
1	7	Yes	2	0	No	3	0	No	4	0	No																																																																						
5	8	No	6	0	No	7	0	No	8	0	No																																																																						
9	0	No	10	0	No	11	0	No	12	0	No																																																																						
13	0	No	14	0	No	15	0	No	16	0	No																																																																						
17	0	No	18	0	No	19	0	No	20	0	No																																																																						
<p>F1 F2 F3 F4 F5 F6 F7 F8 F9 F10                  HELP HELP LOOKUP EDIT EDIT SETUP A/D PREV EXIT                  SELECT SCREEN FREQ CHANLS SYSTEM GROUP BANKS MENU PROG</p>																																																																																	
<p>Enter Home Repeater Number between 1 and 20</p>																																																																																	

Parameter	Available Responses	Description
Alpha Tag	A-Z, 0-9, etc.	Changes the eight-character alpha tag for the selected system. The system alpha tag is displayed only by high tier models which have the alpha tag display mode enabled (Section 3.4.4).
Home	1-20	Programs the number of the home repeater of the transceiver (Section 4.7.1).
Area	0, 1	Selects the area of the LTR system. "0" is usually programmed unless two systems are close enough to interfere with each other. One is then programmed "0" and the other "1".
Repeater Interconnect	1-250	Programs the block of Repeater Interconnect ID codes up to all 250. If an ID code within this block is selected or decoded, the transceiver enters the interconnect operating mode and telephone calls can be placed or received.

Table 4-3 LTR System Parameters (Continued)

Parameter	Available Responses	Description
Transmit Inhibit ID	1-250	Programs the block of transmit inhibit ID codes up to all 250. If an ID code within this block is decoded up to 5 seconds before the PTT switch is pressed, the transmitter does not key (Section 3.8.6).
Block Decode	1-250	Programs a block of ID codes up to all 250 that are decoded regardless of the group selected (Section 3.8.1).
Power Level	Low tier - High, Low High tier - High, Low 1, Low 2, Low 3, Low 4	Programs the output power selected by the system. The power output produced by these levels is set during alignment (Section 3.5.14).
Busy Queue	Yes, No	Programs if Busy Queuing is enabled on the system (Section 3.8.7).
Group Scan	Enabled, Disabled	Programs if group scanning occurs on the system. If "Disabled" is programmed, it cannot be selected (Section 3.7.1).
Scan List	Yes, No	Programs the default scan list status of the system. This programming is overridden by A/D key if it is enabled (Section 3.7.2).
Companding	Yes, No	Programs if optional companding is used on the system (Section 3.5.4). The output line controlling companding must also be programmed for that function (Section 4.9).
Priority 1/2 Decode	1-250	Programs the priority decode (receive) ID codes (Section 3.8.3).
Priority 1/2 Call Light	Yes, No	Programs if the Call indicator lights when a call is received on that priority ID code (Section 3.5.3).
Priority 1/2 Horn	Yes, No	Programs if the horn sounds when a call is received on that ID code (Section 3.5.10).
Priority 1/2 Encrypt	Yes, No	Programs if encryption is used on calls received on that ID code (Section 3.5.7).
Channel Table	1 only - Low tier 1-3 - High tier	With low tier models, only one channel table is available, so this number is always "1". With high tier models, up to three tables can be programmed, and this number selects the table used by the system (Section 4.7.2).
Emergency System/ Group; Automatic (high tier only)	Any programmed system/ group. Automatic = N/A	Emergency calls are available only with high tier models. This programs the system/group used for emergency calls on the system. If no system/group is programmed, the bank system/group is used. Automatically transmitted calls are not available with LTR 98xx models (Section 3.5.6).
NO./CHN (Number/Channel)	Any channel number from channel table	Programs the channels of the LTR repeaters accessed by the system. These are the channels assigned in the above channel table, not FCC channel numbers. Press F3 to display the channel table (Sections 4.7.1 and 4.7.2).
RIC	Yes, No	Programs if the repeater is equipped with an interconnect controller (Section 4.7.3).

**Table 4-3 LTR System Parameters (Continued)**

LTR GROUP PARAMETERS											
(The Group Parameter screen is selected by pressing F6.)											
E.F. Johnson Platform Radio Programmer Version 203 COPYRIGHT 1997											
FREE SPACE: 3658/ 239			RADIO MODEL: 988220X				FILE NAME: NEW				
CREATE/MODIFY LTR GROUP/CHANNEL INFO											
		ASN	ALPHA TAG	GRP ENC	GRP DEC	CALL LIGHT	HORN	ENCRYPT	SCAN LIST	TRANS-POND	DATA
GROUP 1	Yes	DISP001		1	1	Disabled	Disabled	N/A	Yes	Disabled	No
GROUP 2	Yes	PRI2-003		3	3	Enabled	Disabled	N/A	Yes	Disabled	No
GROUP 3	Yes	DISP025		25	25	Disabled	Disabled	N/A	Yes	Disabled	No
GROUP 4	Yes	DISP026		26	26	Disabled	Disabled	N/A	Yes	Disabled	No
GROUP 5	Yes	DISP060		60	60	Disabled	Disabled	N/A	Yes	Disabled	No
GROUP 6	Yes	DISP061		61	61	Disabled	Disabled	N/A	Yes	Disabled	No
GROUP 7	Yes	TEL200		200	200	Disabled	Disabled	N/A	Yes	Disabled	No
GROUP 8	Yes	TEL201		201	201	Enabled	Disabled	N/A	Yes	Disabled	No
GROUP 9	Yes	TRANS004		4	4	Disabled	Disabled	N/A	Yes	Enabled	No
GROUP 10	Yes	TRANS005		5	5	Disabled	Disabled	N/A	Yes	Enabled	No
GROUP 11	Yes	DISP050		50	50	Disabled	Disabled	N/A	Yes	Disabled	No
GROUP 12	Yes	DISP004		4	4	Enabled	Disabled	N/A	Yes	Disabled	No
GROUP 13	No			0	0	Disabled	Disabled	N/A	Yes	Disabled	No
GROUP 14	No			0	0	Disabled	Disabled	N/A	Yes	Disabled	No
GROUP 15	No			0	0	Disabled	Disabled	N/A	Yes	Disabled	No
GROUP 16	No			0	0	Disabled	Disabled	N/A	Yes	Disabled	No
F1	F2	F3	F4	F5	F6	F7	F8	F9	F10		
HELP	HELP							PREV	EXIT		
SELECT	SCREEN							MENU	PROG		
Use Space Bar to Select											

Parameter	Available Responses	Description
Asn (Assigned)	Yes, No	Specifies if the group will be selectable.
Alpha Tag	A-Z, 0-9, etc.	With the high tier models, specifies the eight-character alpha tag that is displayed when the group is selected. With low tier models, the group alpha tag is used only for programming and is not displayed by the transceiver (Section 3.4.4).
Group Enc/Dec (Encode/Decode)	1-250	Specifies the encode (transmit) and decode (receive) ID codes for that selectable group.
Call Light	Enabled, Disabled	Programs if the Call indicator lights when a call is received on that group (Section 3.5.3).
Horn	Enabled, Disabled	Programs if the horn sounds when a call is received on that group (Section 3.5.10).
Encrypt	Enabled, Disabled	Programs if encryption is used on calls received and transmitted on that ID code (Section 3.5.7). The output line controlling encryption must also be programmed for that function (Section 4.9).
Scan List	Yes, No	Programs the default scan list status of the group ("Yes" = in scan list). This programming can be overridden by A/D key if it is enabled (Section 3.7.2).
Transpond	Enabled, Disabled	Programs if transponding occurs when a call is received on that group (Section 3.8.9).
Data	Yes, No	Programs if that group can be used for data transmissions (Section 3.5.5).

NOTE: Refer to Section 4.6.5 for more information on programming the parameters in the following table.

**Table 4-4 Conventional System Parameters**

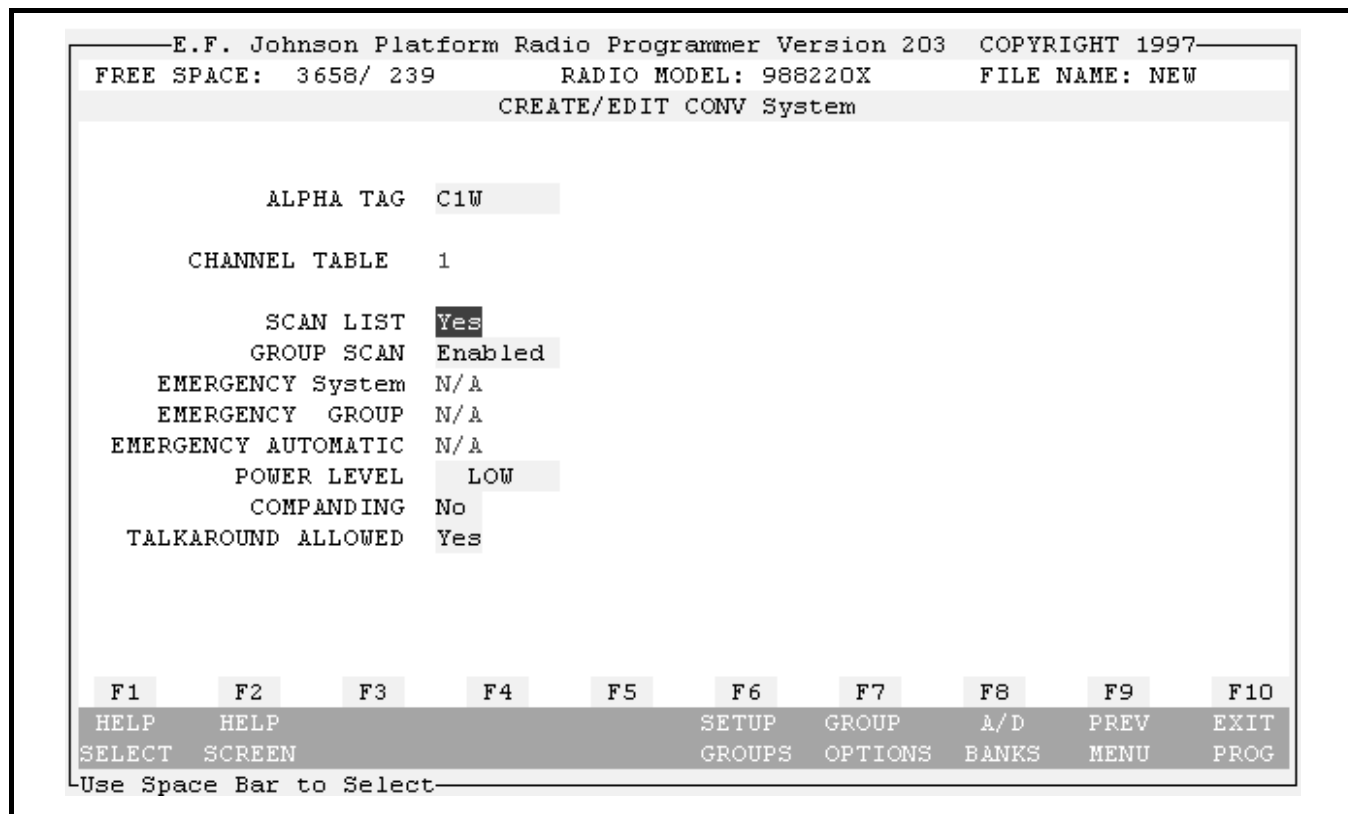

Parameter	Available Responses	Description
Alpha Tag	A-Z, 0-9, etc.	Changes the eight-character alpha tag for the selected system. The system alpha tag is displayed only by high tier models which have the alpha tag display mode enabled (Section 3.4.4).
Channel Table	1 only - Low tier 1-3 - High tier	With low tier models, only one channel table is available, so this number is always "1". With high tier models, up to three tables can be programmed and this number selects the one used by the system (Section 4.7.2).
Scan List	Yes, No	Programs the default scan list status of the system. This programming can be overridden by A/D key if it is enabled (Section 3.7.2).
Group Scan	Enabled, Disabled	Programs if group scanning occurs on the system. If "Disabled" is programmed, it cannot be selected (Section 3.7.1).
Emergency System/ Group; Automatic (high tier only)	Any programmed system/ group. Automatic = N/A	Emergency calls are available only with high tier models. This programs the system/group used for emergency calls on the system. If no system/group is programmed, the bank system/group is used. Automatically transmitted calls are not available with LTR 98xx models (Section 3.5.6).
Power Level	Low tier - High, Low High tier - High, Low 1, Low 2, Low 3, Low 4	Programs the output power selected by this system. The power output produced by these levels is set during alignment (Section 3.5.14).
Companding	Yes, No	Programs if optional companding is used on the system (Section 3.5.4). The output line controlling companding must also be programmed for that function (Section 4.9).
Talk-Around Allowed	Yes, No	Programs if talk-around can be programmed on any of the groups in the system (Section 3.9.4).

Table 4-4 Conventional System Parameters (Continued)

CONVENTIONAL GROUP PARAMETERS 1										
(Group Following Parameter Screen 1 is selected by pressing F6 from the Conventional System Screen)										
E.F. Johnson Platform Radio Programmer Version 204 COPYRIGHT 1997, 1998										
FREE SPACE: 5364/ 234			RADIO MODEL: 984343X				FILE NAME: PERH0825			
CREATE/MODIFY CONU GROUP INFO										
G#	ASN	ALPHA	CHN	RIC	TX CCG	CG VAL	AND EXT	RX CCG	CG VAL	AND EXT
1	Yes	C430NCG	1	No	None		No	None		No
2	Yes	C430T67	1	No	TCG	1	No	TCG	1	No
3	Yes	C430T210	1	No	TCG	33	No	TCG	33	No
4	Yes	C430D532	1	No	DCG	532	No	DCG	532	No
5	Yes	C430I532	1	No	DCG	532	No	DCG	532	No
6	Yes	C440NCG	2	No	None		No	None		No
7	Yes	C440T67	2	No	TCG	1	No	TCG	1	No
8	Yes	C440T210	2	No	TCG	33	No	TCG	33	No
9	Yes	C440D532	2	No	DCG	532	No	DCG	532	No
10	Yes	C440I532	2	No	DCG	532	No	DCG	532	No
11	Yes	C450NCG	3	No	None		No	None		No
12	Yes	C450T67	3	No	TCG	1	No	TCG	1	No
13	Yes	C450T210	3	No	TCG	33	No	TCG	33	No
14	Yes	C450D532	3	No	DCG	532	No	DCG	532	No
15	Yes	C450I532	3	No	IDCG	532	No	IDCG	532	No
16	Yes	C446NCG	10	No	None		No	None		No
F1	F2	F3	F4	F5	F6	F7	F8	F9	F10	
HELP	HELP	LOOKUP						PREU	EXIT	
SELECT	SCREEN	FREQ						MENU	PROG	
Use Space Bar to Select										
Parameter	Available Responses	Description								
Asn	Yes, No	Specifies if the group will be selectable. This also changes this parameter on the second group parameter screen.								
Alpha Tag	A-Z, 0-9, etc.	With the high tier models, specifies the eight-character alpha tag that is displayed when the group is selected. With low tier models, the group alpha tag is used only for programming and is not displayed by the transceiver (Section 3.4.4).								
CHN (Channel)	Any channel number from channel table	Programs the channel selected by the group. These are the channels assigned in the above channel table, not FCC channel numbers. Press F3 to display the channel table (Sections 4.7.1 and 4.7.2).								
RIC	Yes, No	Programs if the repeater is equipped with an interconnect controller (Section 4.7.3).								
Tx CG	None, TCG, DCG, IDCG	Programs the type of transmit Call Guard squelch for the indicated group (Sections 3.9.5 and 3.9.7).								
TCG = Tone (CTCSS), DCG = digital (CDCSS), IDCG = Inverted digital										
CG Value (Tx)	Tone number or digital code	If CG was selected, the tone number from 1-42 is entered. If digital was selected, the digital code is selected. These numbers are listed in Table 4-5.								
AND Ext (Tx)	Yes, No	If "Yes" is programmed, an External encoder is "ANDed" with the Call Guard squelch signal if one is programmed (Section 3.9.7).								
Rx CG	None, TCG, DCG, IDCG	Programs the type of Receive Call Guard squelch for the indicated group (Sections 3.9.5 and 3.9.7).								

**Table 4-4 Conventional System Parameters (Continued)**

Parameter	Available Responses	Description
CG Value (Rx)	Tone number or digital code	If CG was selected, the tone number from 1-42 is entered. If digital was selected, the digital code is selected. These numbers are listed in Table 4-5.
AND Ext (Rx)	Yes, No	If “Yes” is programmed, an External decoder is “ANDed” with the Call Guard squelch signal if one is programmed (Section 3.9.7).

**CONVENTIONAL GROUP PARAMETERS 2**

(Group Parameter Screen 2 is selected by pressing F7 from the Conventional System Screen)

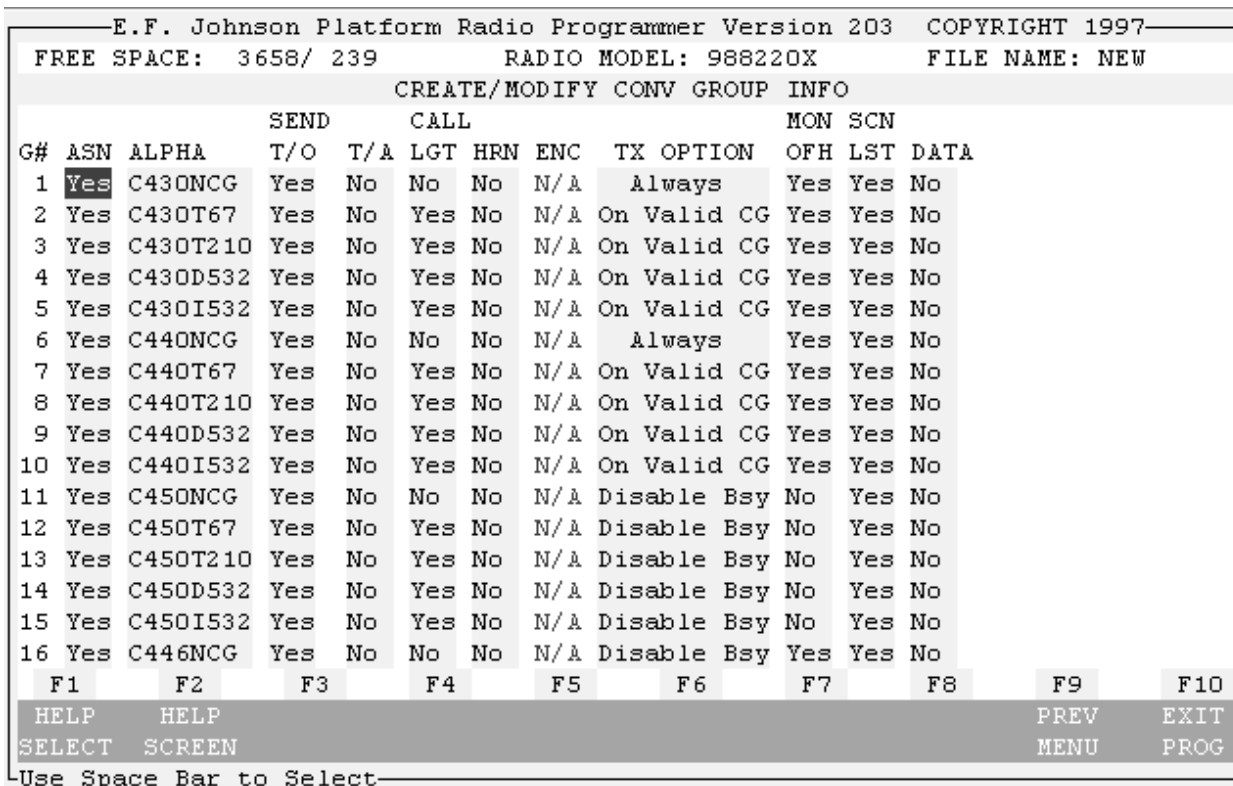

Parameter	Available Responses	Description
Asn	Yes, No	Specifies if the group will be selectable. This also changes this parameter on the first group parameter screen.
Alpha Tag	A-Z, 0-9, etc.	With the high tier models, specifies the eight-character alpha tag that is displayed when the group is selected. With low tier models, the group alpha tag is used only for programming and is not displayed by the transceiver (Section 3.4.4).
Send T/O (Transmit Turn-Off Code)	Yes, No	If “yes” is programmed, the Call Guard turn-off code is sent when the PTT switch is released (Section 3.9.5).
T/A (Talk-Around)	Yes, No	If “yes” is programmed, transmission is on the receive frequency (Section 3.9.4). In addition, if equipped with a T/A option switch, talk-around cannot be turned off by that switch on the group. “NA” is displayed if talk-around was disabled on the system screen.
Call LGT (Light)	Yes, No	Programs if the Call indicator lights when a call is received on that group (Section 3.5.3).
HRN (Horn)	Yes, No	Programs if the horn sounds when a call is received on that group (Section 3.5.10).

**Table 4-4 Conventional System Parameters (Continued)**

Parameter	Available Responses	Description
ENC (Encryption)	Yes, No	Programs if optional encryption is used on calls received and transmitted on that group (Section 3.5.7). The output line controlling encryption must also be programmed for that function (Section 4.9).
TX OPTION	Always, Disable Bsy, On Valid CG, Disable	<b>Always</b> = Tx enabled, TDOB (Transmit Disable On Busy) disabled <b>Disable Busy</b> = Tx and TDOB enabled, no transmit w/valid Call Guard <b>On Valid CG</b> = Tx and TDOB enabled, transmit allowed w/valid CG <b>Disabled</b> = Tx disabled (receive-only channel) (Sections 3.9.2 and 3.9.3).
MON OFH (Monitor Off-Hook)	Yes, No	Programs if monitoring is enabled when the microphone is taken off-hook (Section 3.9.1).
SCN LST (Scan List)	Yes, No	Programs the default scan list status of the group ("Yes" = in scan list). This programming can be overridden by A/D key if it is enabled (Section 3.7.2).
Data	Yes, No	Programs if that group can be used for data transmissions (Section 3.5.5).

**Table 4-5 Call Guard Codes and Tones**

Recommended Tone Call Guard Codes									
Code	Freq	Code	Freq	Code	Freq	Code	Freq	Code	Freq
		09	91.5	18	123.0	27	167.9	36*	233.6
01	67.0	10	94.8	19	127.3	28	173.8	37*	241.8
02	71.9	11**	97.4	20	131.8	29	179.9	38*	250.3
03	74.4	12	100.0	21	136.5	30	186.2	39**	69.3
04	77.0	13	103.5	22	141.3	31	192.8	40**	206.5
05	79.7	14	107.2	23	146.2	32	203.5	41* **	229.1
06	82.5	15	110.9	24	151.4	33	210.7	42* **	254.1
07	85.4	16	114.8	25	156.7	34*	218.1		
08	88.5	17	118.8	26	162.2	35*	225.7		
* These tones normally are not used because of their close proximity to the voice frequencies.									
** This tone is normally not used because it may cause interference with adjacent tones.									
Recommended Digital Call Guard Codes									
023	065	131	172	261	346	431	532	654	743
025	071	132	174	263	351	432	546	662	754
026	072	134	205	265	364	445	565	664	
031	073	143	223	271	365	464	606	703	
032	074	152	226	306	371	465	612	712	
043	114	155	243	311	411	466	624	723	
047	115	156	244	315	412	503	627	731	
051	116	162	245	331	413	506	631	732	
054	125	165	251	343	423	516	632	734	

## 800 MHz Channels

FCC Chan. No. [1]	Mobile Rx Freq.	Mobile Tx Freq	FCC Chan. No. [1]	Mobile Rx Freq.	Mobile Tx Freq	FCC Chan. No. [1]	Mobile Rx Freq	Mobile Tx Freq
1	851.0125	806.0125	48	852.1875	807.1875	95	853.3625	808.3625
2	851.0375	806.0375	49	852.2125	807.2125	96	853.3875	808.3875
3	851.0625	806.0625	50	852.2375	807.2375	97	853.4125	808.4125
4	851.0875	806.0875	51	852.2625	807.2625	98	853.4375	808.4375
5	851.1125	806.1125	52	852.2875	807.2875	99	853.4625	808.4625
6	851.1375	806.1375	53	852.3125	807.3125	100	853.4875	808.4875
7	851.1625	806.1625	54	852.3375	807.3375	101	853.5125	808.5125
8	851.1875	806.1875	55	852.3625	807.3625	102	853.5375	808.5375
9	851.2125	806.2125	56	852.3875	807.3875	103	853.5625	808.5625
10	851.2375	806.2375	57	852.4125	807.4125	104	853.5875	808.5875
11	851.2625	806.2625	58	852.4375	807.4375	105	853.6125	808.6125
12	851.2875	806.2875	59	852.4625	807.4625	106	853.6375	808.6375
13	851.3125	806.3125	60	852.4875	807.4875	107	853.6625	808.6625
14	851.3375	806.3375	61	852.5125	807.5125	108	853.6875	808.6875
15	851.3625	806.3625	62	852.5375	807.5375	109	853.7125	808.7125
16	851.3875	806.3875	63	852.5625	807.5625	110	853.7375	808.7375
17	851.4125	806.4125	64	852.5875	807.5875	111	853.7625	808.7625
18	851.4375	806.4375	65	852.6125	807.6125	112	853.7875	808.7875
19	851.4625	806.4625	66	852.6375	807.6375	113	853.8125	808.8125
20	851.4875	806.4875	67	852.6625	807.6625	114	853.8375	808.8375
21	851.5125	806.5125	68	852.6875	807.6875	115	853.8625	808.8625
22	851.5375	806.5375	69	852.7125	807.7125	116	853.8875	808.8875
23	851.5625	806.5625	70	852.7375	807.7375	117	853.9125	808.9125
24	851.5875	806.5875	71	852.7625	807.7625	118	853.9375	808.9375
25	851.6125	806.6125	72	852.7875	807.7875	119	853.9625	808.9625
26	851.6375	806.6375	73	852.8125	807.8125	120	853.9875	808.9875
27	851.6625	806.6625	74	852.8375	807.8375	121	854.0125	809.0125
28	851.6875	806.6875	75	852.8625	807.8625	122	854.0375	809.0375
29	851.7125	806.7125	76	852.8875	807.8875	123	854.0625	809.0625
30	851.7375	806.7375	77	852.9125	807.9125	124	854.0875	809.0875
31	851.7625	806.7625	78	852.9375	807.9375	125	854.1125	809.1125
32	851.7875	806.7875	79	852.9625	807.9625	126	854.1375	809.1375
33	851.8125	806.8125	80	852.9875	807.9875	127	854.1625	809.1625
34	851.8375	806.8375	81	853.0125	808.0125	128	854.1875	809.1875
35	851.8625	806.8625	82	853.0375	808.0375	129	854.2125	809.2125
36	851.8875	806.8875	83	853.0625	808.0625	130	854.2375	809.2375
37	851.9125	806.9125	84	853.0875	808.0875	131	854.2625	809.2625
38	851.9375	806.9375	85	853.1125	808.1125	132	854.2875	809.2875
39	851.9625	806.9625	86	853.1375	808.1375	133	854.3125	809.3125
40	851.9875	806.9875	87	853.1625	808.1625	134	854.3375	809.3375
41	852.0125	807.0125	88	853.1875	808.1875	135	854.3625	809.3625
42	852.0375	807.0375	89	853.2125	808.2125	136	854.3875	809.3875
43	852.0625	807.0625	90	853.2375	808.2375	137	854.4125	809.4125
44	852.0875	807.0875	91	853.2625	808.2625	138	854.4375	809.4375
45	852.1125	807.1125	92	853.2875	808.2875	139	854.4625	809.4625
46	852.1375	807.1375	93	853.3125	808.3125	140	854.4875	809.4875
47	852.1625	807.1625	94	853.3375	808.3375	141	854.5125	809.5125

[1] Do not use the FCC channel number to program a channel. Use the channel number from the channel table selected by pressing F6 in the Main Radio Parameters screen (see Section 4.7.2).



## 800 MHz Channels

FCC Chan. No. [1]	Mobile Rx Freq.	Mobile Tx Freq	FCC Chan. No. [1]	Mobile Rx Freq.	Mobile Tx Freq	FCC Chan. No. [1]	Mobile Rx Freq	Mobile Tx Freq
142	854.5375	809.5375	189	855.7125	810.7125	236	856.8875	811.8875
143	854.5625	809.5625	190	855.7375	810.7375	237	856.9125	811.9125
144	854.5875	809.5875	191	855.7625	810.7625	238	856.9375	811.9375
145	854.6125	809.6125	192	855.7875	810.7875	239	856.9625	811.9625
146	854.6375	809.6375	193	855.8125	810.8125	240	856.9875	811.9875
147	854.6625	809.6625	194	855.8375	810.8375	241	857.0125	812.0125
148	854.6875	809.6875	195	855.8625	810.8625	242	857.0375	812.0375
149	854.7125	809.7125	196	855.8875	810.8875	243	857.0625	812.0625
150	854.7375	809.7375	197	855.9125	810.9125	244	857.0875	812.0875
151	854.7625	809.7625	198	855.9375	810.9375	245	857.1125	812.1125
152	854.7875	809.7875	199	855.9625	810.9625	246	857.1375	812.1375
153	854.8125	809.8125	200	855.9875	810.9875	247	857.1625	812.1625
154	854.8375	809.8375	201	856.0125	811.0125	248	857.1875	812.1875
155	854.8625	809.8625	202	856.0375	811.0375	249	857.2125	812.2125
156	854.8875	809.8875	203	856.0625	811.0625	250	857.2375	812.2375
157	854.9125	809.9125	204	856.0875	811.0875	251	857.2625	812.2625
158	854.9375	809.9375	205	856.1125	811.1125	252	857.2875	812.2875
159	854.9625	809.9625	206	856.1375	811.1375	253	857.3125	812.3125
160	854.9875	809.9875	207	856.1625	811.1625	254	857.3375	812.3375
161	855.0125	810.0125	208	856.1875	811.1875	255	857.3625	812.3625
162	855.0375	810.0375	209	856.2125	811.2125	256	857.3875	812.3875
163	855.0625	810.0625	210	856.2375	811.2375	257	857.4125	812.4125
164	855.0875	810.0875	211	856.2625	811.2625	258	857.4375	812.4375
165	855.1125	810.1125	212	856.2875	811.2875	259	857.4625	812.4625
166	855.1375	810.1375	213	856.3125	811.3125	260	857.4875	812.4875
167	855.1625	810.1625	214	856.3375	811.3375	261	857.5125	812.5125
168	855.1875	810.1875	215	856.3625	811.3625	262	857.5375	812.5375
169	855.2125	810.2125	216	856.3875	811.3875	263	857.5625	812.5625
170	855.2375	810.2375	217	856.4125	811.4125	264	857.5875	812.5875
171	855.2625	810.2625	218	856.4375	811.4375	265	857.6125	812.6125
172	855.2875	810.2875	219	856.4625	811.4625	266	857.6375	812.6375
173	855.3125	810.3125	220	856.4875	811.4875	267	857.6625	812.6625
174	855.3375	810.3375	221	856.5125	811.5125	268	857.6875	812.6875
175	855.3625	810.3625	222	856.5375	811.5375	269	857.7125	812.7125
176	855.3875	810.3875	223	856.5625	811.5625	270	857.7375	812.7375
177	855.4125	810.4125	224	856.5875	811.5875	271	857.7625	812.7625
178	855.4375	810.4375	225	856.6125	811.6125	272	857.7875	812.7875
179	855.4625	810.4625	226	856.6375	811.6375	273	857.8125	812.8125
180	855.4875	810.4875	227	856.6625	811.6625	274	857.8375	812.8375
181	855.5125	810.5125	228	856.6875	811.6875	275	857.8625	812.8625
182	855.5375	810.5375	229	856.7125	811.7125	276	857.8875	812.8875
183	855.5625	810.5625	230	856.7375	811.7375	277	857.9125	812.9125
184	855.5875	810.5875	231	856.7625	811.7625	278	857.9375	812.9375
185	855.6125	810.6125	232	856.7875	811.7875	279	857.9625	812.9625
186	855.6375	810.6375	233	856.8125	811.8125	280	857.9875	812.9875
187	855.6625	810.6625	234	856.8375	811.8375	281	858.0125	813.0125
188	855.6875	810.6875	235	856.8625	811.8625	282	858.0375	813.0375

[1] Do not use the FCC channel number to program a channel. Use the channel number from the channel table selected by pressing F6 in the Main Radio Parameters screen (see Section 4.7.2).

## 800 MHz Channels

FCC Chan. No. [1]	Mobile Rx Freq.	Mobile Tx Freq	FCC Chan. No. [1]	Mobile Rx Freq.	Mobile Tx Freq	FCC Chan. No. [1]	Mobile Rx Freq	Mobile Tx Freq
283	858.0625	813.0625	330	859.2375	814.2375	377	860.4125	815.4125
284	858.0875	813.0875	331	859.2625	814.2625	378	860.4375	815.4375
285	858.1125	813.1125	332	859.2875	814.2875	379	860.4625	815.4625
286	858.1375	813.1375	333	859.3125	814.3125	380	860.4875	815.4875
287	858.1625	813.1625	334	859.3375	814.3375	381	860.5125	815.5125
288	858.1875	813.1875	335	859.3625	814.3625	382	860.5375	815.5375
289	858.2125	813.2125	336	859.3875	814.3875	383	860.5625	815.5625
290	858.2375	813.2375	337	859.4125	814.4125	384	860.5875	815.5875
291	858.2625	813.2625	338	859.4375	814.4375	385	860.6125	815.6125
292	858.2875	813.2875	339	859.4625	814.4625	386	860.6375	815.6375
293	858.3125	813.3125	340	859.4875	814.4875	387	860.6625	815.6625
294	858.3375	813.3375	341	859.5125	814.5125	388	860.6875	815.6875
295	858.3625	813.3625	342	859.5375	814.5375	389	860.7125	815.7125
296	858.3875	813.3875	343	859.5625	814.5625	390	860.7375	815.7375
297	858.4125	813.4125	344	859.5875	814.5875	391	860.7625	815.7625
298	858.4375	813.4375	345	859.6125	814.6125	392	860.7875	815.7875
299	858.4625	813.4625	346	859.6375	814.6375	393	860.8125	815.8125
300	858.4875	813.4875	347	859.6625	814.6625	394	860.8375	815.8375
301	858.5125	813.5125	348	859.6875	814.6875	395	860.8625	815.8625
302	858.5375	813.5375	349	859.7125	814.7125	396	860.8875	815.8875
303	858.5625	813.5625	350	859.7375	814.7375	397	860.9125	815.9125
304	858.5875	813.5875	351	859.7625	814.7625	398	860.9375	815.9375
305	858.6125	813.6125	352	859.7875	814.7875	399	860.9625	815.9625
306	858.6375	813.6375	353	859.8125	814.8125	400	860.9875	815.9875
307	858.6625	813.6625	354	859.8375	814.8375	401	861.0125	816.0125
308	858.6875	813.6875	355	859.8625	814.8625	402	861.0375	816.0375
309	858.7125	813.7125	356	859.8875	814.8875	403	861.0625	816.0625
310	858.7375	813.7375	357	859.9125	814.9125	404	861.0875	816.0875
311	858.7625	813.7625	358	859.9375	814.9375	405	861.1125	816.1125
312	858.7875	813.7875	359	859.9625	814.9625	406	861.1375	816.1375
313	858.8125	813.8125	360	859.9875	814.9875	407	861.1625	816.1625
314	858.8375	813.8375	361	860.0125	815.0125	408	861.1875	816.1875
315	858.8625	813.8625	362	860.0375	815.0375	409	861.2125	816.2125
316	858.8875	813.8875	363	860.0625	815.0625	410	861.2375	816.2375
317	858.9125	813.9125	364	860.0875	815.0875	411	861.2625	816.2625
318	858.9375	813.9375	365	860.1125	815.1125	412	861.2875	816.2875
319	858.9625	813.9625	366	860.1375	815.1375	413	861.3125	816.3125
320	858.9875	813.9875	367	860.1625	815.1625	414	861.3375	816.3375
321	859.0125	814.0125	368	860.1875	815.1875	415	861.3625	816.3625
322	859.0375	814.0375	369	860.2125	815.2125	416	861.3875	816.3875
323	859.0625	814.0625	370	860.2375	815.2375	417	861.4125	816.4125
324	859.0875	814.0875	371	860.2625	815.2625	418	861.4375	816.4375
325	859.1125	814.1125	372	860.2875	815.2875	419	861.4625	816.4625
326	859.1375	814.1375	373	860.3125	815.3125	420	861.4875	816.4875
327	859.1625	814.1625	374	860.3375	815.3375	421	861.5125	816.5125
328	859.1875	814.1875	375	860.3625	815.3625	422	861.5375	816.5375
329	859.2125	814.2125	376	860.3875	815.3875	423	861.5625	816.5625

[1] Do not use the FCC channel number to program a channel. Use the channel number from the channel table selected by pressing F6 in the Main Radio Parameters screen (see Section 4.7.2).

## 800 MHz Channels

FCC Chan. No. [1]	Mobile Rx Freq.	Mobile Tx Freq	FCC Chan. No. [1]	Mobile Rx Freq.	Mobile Tx Freq	FCC Chan. No. [1]	Mobile Rx Freq	Mobile Tx Freq
424	861.5875	816.5875	471	862.7625	817.7625	518	863.9375	818.9375
425	861.6125	816.6125	472	862.7875	817.7875	519	863.9625	818.9625
426	861.6375	816.6375	473	862.8125	817.8125	520	863.9875	818.9875
427	861.6625	816.6625	474	862.8375	817.8375	521	864.0125	819.0125
428	861.6875	816.6875	475	862.8625	817.8625	522	864.0375	819.0375
429	861.7125	816.7125	476	862.8875	817.8875	523	864.0625	819.0625
430	861.7375	816.7375	477	862.9125	817.9125	524	864.0875	819.0875
431	861.7625	816.7625	478	862.9375	817.9375	525	864.1125	819.1125
432	861.7875	816.7875	479	862.9625	817.9625	526	864.1375	819.1375
433	861.8125	816.8125	480	862.9875	817.9875	527	864.1625	819.1625
434	861.8375	816.8375	481	863.0125	818.0125	528	864.1875	819.1875
435	861.8625	816.8625	482	863.0375	818.0375	529	864.2125	819.2125
436	861.8875	816.8875	483	863.0625	818.0625	530	864.2375	819.2375
437	861.9125	816.9125	484	863.0875	818.0875	531	864.2625	819.2625
438	861.9375	816.9375	485	863.1125	818.1125	532	864.2875	819.2875
439	861.9625	816.9625	486	863.1375	818.1375	533	864.3125	819.3125
440	861.9875	816.9875	487	863.1625	818.1625	534	864.3375	819.3375
441	862.0125	817.0125	488	863.1875	818.1875	535	864.3625	819.3625
442	862.0375	817.0375	489	863.2125	818.2125	536	864.3875	819.3875
443	862.0625	817.0625	490	863.2375	818.2375	537	864.4125	819.4125
444	862.0875	817.0875	491	863.2625	818.2625	538	864.4375	819.4375
445	862.1125	817.1125	492	863.2875	818.2875	539	864.4625	819.4625
446	862.1375	817.1375	493	863.3125	818.3125	540	864.4875	819.4875
447	862.1625	817.1625	494	863.3375	818.3375	541	864.5125	819.5125
448	862.1875	817.1875	495	863.3625	818.3625	542	864.5375	819.5375
449	862.2125	817.2125	496	863.3875	818.3875	543	864.5625	819.5625
450	862.2375	817.2375	497	863.4125	818.4125	544	864.5875	819.5875
451	862.2625	817.2625	498	863.4375	818.4375	545	864.6125	819.6125
452	862.2875	817.2875	499	863.4625	818.4625	546	864.6375	819.6375
453	862.3125	817.3125	500	863.4875	818.4875	547	864.6625	819.6625
454	862.3375	817.3375	501	863.5125	818.5125	548	864.6875	819.6875
455	862.3625	817.3625	502	863.5375	818.5375	549	864.7125	819.7125
456	862.3875	817.3875	503	863.5625	818.5625	550	864.7375	819.7375
457	862.4125	817.4125	504	863.5875	818.5875	551	864.7625	819.7625
458	862.4375	817.4375	505	863.6125	818.6125	552	864.7875	819.7875
459	862.4625	817.4625	506	863.6375	818.6375	553	864.8125	819.8125
460	862.4875	817.4875	507	863.6625	818.6625	554	864.8375	819.8375
461	862.5125	817.5125	508	863.6875	818.6875	555	864.8625	819.8625
462	862.5375	817.5375	509	863.7125	818.7125	556	864.8875	819.8875
463	862.5625	817.5625	510	863.7375	818.7375	557	864.9125	819.9125
464	862.5875	817.5875	511	863.7625	818.7625	558	864.9375	819.9375
465	862.6125	817.6125	512	863.7875	818.7875	559	864.9625	819.9625
466	862.6375	817.6375	513	863.8125	818.8125	560	864.9875	819.9875
467	862.6625	817.6625	514	863.8375	818.8375	561	865.0125	820.0125
468	862.6875	817.6875	515	863.8625	818.8625	562	865.0375	820.0375
469	862.7125	817.7125	516	863.8875	818.8875	563	865.0625	820.0625
470	862.7375	817.7375	517	863.9125	818.9125	564	865.0875	820.0875

[1] Do not use the FCC channel number to program a channel. Use the channel number from the channel table selected by pressing F6 in the Main Radio Parameters screen (see Section 4.7.2).

## 800 MHz Channels

FCC Chan. No. [1]	Mobile Rx Freq.	Mobile Tx Freq	FCC Chan. No. [1]	Mobile Rx Freq.	Mobile Tx Freq	FCC Chan. No. [1]	Mobile Rx Freq	Mobile Tx Freq
565	865.1125	820.1125	610	866.1375	821.1375	655	866.7250	821.7250
566	865.1375	820.1375	611	866.1500	821.1500	656	866.7375	821.7375
567	865.1625	820.1625	612	866.1625	821.1625	657	866.7500	821.7500
568	865.1875	820.1875	613	866.1750	821.1750	658	866.7625	821.7625
569	865.2125	820.2125	614	866.1875	821.1875	659	866.7750	821.7750
570	865.2375	820.2375	615	866.2000	821.2000	660	866.7875	821.7875
571	865.2625	820.2625	616	866.2125	821.2125	661	866.8000	821.8000
572	865.2875	820.2875	617	866.2250	821.2250	662	866.8125	821.8125
573	865.3125	820.3125	618	866.2375	821.2375	663	866.8250	821.8250
574	865.3375	820.3375	619	866.2500	821.2500	664	866.8375	821.8375
575	865.3625	820.3625	620	866.2625	821.2625	665	866.8500	821.8500
576	865.3875	820.3875	621	866.2750	821.2750	666	866.8625	821.8625
577	865.4125	820.4125	622	866.2875	821.2875	667	866.8750	821.8750
578	865.4375	820.4375	623	866.3000	821.3000	668	866.8875	821.8875
579	865.4625	820.4625	624	866.3125	821.3125	669	866.9000	821.9000
580	865.4875	820.4875	625	866.3250	821.3250	670	866.9125	821.9125
581	865.5125	820.5125	626	866.3375	821.3375	671	866.9250	821.9250
582	865.5375	820.5375	627	866.3500	821.3500	672	866.9375	821.9375
583	865.5625	820.5625	628	866.3625	821.3625	673	866.9500	821.9500
584	865.5875	820.5875	629	866.3750	821.3750	674	866.9625	821.9625
585	865.6125	820.6125	630	866.3875	821.3875	675	866.9750	821.9750
586	865.6375	820.6375	631	866.4000	821.4000	676	866.9875	821.9875
587	865.6625	820.6625	632	866.4125	821.4125	-	867.0000	822.0000
588	865.6875	820.6875	633	866.4250	821.4250	677	867.0125	822.0125
589	865.7125	820.7125	634	866.4375	821.4375	-	867.0250	822.0250
590	865.7375	820.7375	635	866.4500	821.4500	678	867.0375	822.0375
591	865.7625	820.7625	636	866.4625	821.4625	679	867.0500	822.0500
592	865.7875	820.7875	637	866.4750	821.4750	680	867.0625	822.0625
593	865.8125	820.8125	638	866.4875	821.4875	681	867.0750	822.0750
594	865.8375	820.8375	-	866.5000	821.5000	682	867.0875	822.0875
595	865.8625	820.8625	639	866.5125	821.5125	683	867.1000	822.1000
596	865.8875	820.8875	-	866.5250	821.5250	684	867.1125	822.1125
597	865.9125	820.9125	640	866.5375	821.5375	685	867.1250	822.1250
598	865.9375	820.9375	641	866.5500	821.5500	686	867.1375	822.1375
599	865.9625	820.9625	642	866.5625	821.5625	687	867.1500	822.1500
600	865.9875	820.9875	643	866.5750	821.5750	688	867.1625	822.1625
-	866.0000	821.0000	644	866.5875	821.5875	689	867.1750	822.1750
601	866.0125	821.0125	645	866.6000	821.6000	690	867.1875	822.1875
-	866.0250	821.0250	646	866.6125	821.6125	691	867.2000	822.2000
602	866.0375	821.0375	647	866.6250	821.6250	692	867.2125	822.2125
603	866.0500	821.0500	648	866.6375	821.6375	693	867.2250	822.2250
604	866.0625	821.0625	649	866.6500	821.6500	694	867.2375	822.2375
605	866.0750	821.0750	650	866.6625	821.6625	695	867.2500	822.2500
606	866.0875	821.0875	651	866.6750	821.6750	696	867.2625	822.2625
607	866.1000	821.1000	652	866.6875	821.6875	697	867.2750	822.2750
608	866.1125	821.1125	653	866.7000	821.7000	698	867.2875	822.2875
609	866.1250	821.1250	654	866.7125	821.7125	699	867.3000	822.3000

[1] Do not use the FCC channel number to program a channel. Use the channel number from the channel table selected by pressing F6 in the Main Radio Parameters screen (see Section 4.7.2).

## 800 MHz Channels

FCC Chan. No. [1]	Mobile Rx Freq.	Mobile Tx Freq	FCC Chan. No. [1]	Mobile Rx Freq.	Mobile Tx Freq	FCC Chan. No. [1]	Mobile Rx Freq	Mobile Tx Freq
700	867.3125	822.3125	745	867.9000	822.9000	790	868.4875	823.4875
701	867.3250	822.3250	746	867.9125	822.9125	791	868.5000	823.5000
702	867.3375	822.3375	747	867.9250	822.9250	792	868.5125	823.5125
703	867.3500	822.3500	748	867.9375	822.9375	793	868.5250	823.5250
704	867.3625	822.3625	749	867.9500	822.9500	794	868.5375	823.5375
705	867.3750	822.3750	750	867.9625	822.9625	795	868.5500	823.5500
706	867.3875	822.3875	751	867.9750	822.9750	796	868.5625	823.5625
707	867.4000	822.4000	752	867.9875	822.9875	797	868.5750	823.5750
708	867.4125	822.4125	-	868.0000	823.0000	798	868.5875	823.5875
709	867.4250	822.4250	753	868.0125	823.0125	799	868.6000	823.6000
710	867.4375	822.4375	-	868.0250	823.0250	800	868.6125	823.6125
711	867.4500	822.4500	754	868.0375	823.0375	801	868.6250	823.6250
712	867.4625	822.4625	755	868.0500	823.0500	802	868.6375	823.6375
713	867.4750	822.4750	756	868.0625	823.0625	803	868.6500	823.6500
714	867.4875	822.4875	757	868.0750	823.0750	804	868.6625	823.6625
-	867.5000	822.5000	758	868.0875	823.0875	805	868.6750	823.6750
715	867.5125	822.5125	759	868.1000	823.1000	806	868.6875	823.6875
-	867.5250	822.5250	760	868.1125	823.1125	807	868.7000	823.7000
716	867.5375	822.5375	761	868.1250	823.1250	808	868.7125	823.7125
717	867.5500	822.5500	762	868.1375	823.1375	809	868.7250	823.7250
718	867.5625	822.5625	763	868.1500	823.1500	810	868.7375	823.7375
719	867.5750	822.5750	764	868.1625	823.1625	811	868.7500	823.7500
720	867.5875	822.5875	765	868.1750	823.1750	812	868.7625	823.7625
721	867.6000	822.6000	766	868.1875	823.1875	813	868.7750	823.7750
722	867.6125	822.6125	767	868.2000	823.2000	814	868.7875	823.7875
723	867.6250	822.6250	768	868.2125	823.2125	815	868.8000	823.8000
724	867.6375	822.6375	769	868.2250	823.2250	816	868.8125	823.8125
725	867.6500	822.6500	770	868.2375	823.2375	817	868.8250	823.8250
726	867.6625	822.6625	771	868.2500	823.2500	818	868.8375	823.8375
727	867.6750	822.6750	772	868.2625	823.2625	819	868.8500	823.8500
728	867.6875	822.6875	773	868.2750	823.2750	820	868.8625	823.8625
729	867.7000	822.7000	774	868.2875	823.2875	821	868.8750	823.8750
730	867.7125	822.7125	775	868.3000	823.3000	822	868.8875	823.8875
731	867.7250	822.7250	776	868.3125	823.3125	823	868.9000	823.9000
732	867.7375	822.7375	777	868.3250	823.3250	824	868.9125	823.9125
733	867.7500	822.7500	778	868.3375	823.3375	825	868.9250	823.9250
734	867.7625	822.7625	779	868.3500	823.3500	826	868.9375	823.9375
735	867.7750	822.7750	780	868.3625	823.3625	827	868.9500	823.9500
736	867.7875	822.7875	781	868.3750	823.3750	828	868.9625	823.9625
737	867.8000	822.8000	782	868.3875	823.3875	829	868.9750	823.9750
738	867.8125	822.8125	783	868.4000	823.4000	830	868.9875	823.9875
739	867.8250	822.8250	784	868.4125	823.4125	-	869.0000	824.0000
740	867.8375	822.8375	785	868.4250	823.4250	-	869.0125	824.0125
741	867.8500	822.8500	786	868.4375	823.4375	-	869.0250	824.0250
742	867.8625	822.8625	787	868.4500	823.4500	-	869.0375	824.0375
743	867.8750	822.8750	788	868.4625	823.4625	-	869.0500	824.0500
744	867.8875	822.8875	789	868.4750	823.4750	-	869.0625	824.0625

[1] Do not use the FCC channel number to program a channel. Use the channel number from the channel table selected by pressing F6 in the Main Radio Parameters screen (see Section 4.7.2).

## 800 MHz Channels

FCC Chan. No. [1]	Mobile Rx Freq.	Mobile Tx Freq
----------------------	--------------------	-------------------

-	869.0750	824.0750
-	869.0875	824.0875
-	869.1000	824.1000
-	869.1125	824.1125
-	869.1250	824.1250
-	869.1375	824.1375
-	869.1500	824.1500
-	869.1625	824.1625
-	869.1750	824.1750
-	869.1875	824.1875
-	869.2000	824.2000
-	869.2125	824.2125
-	869.2250	824.2250
-	869.2375	824.2375
-	869.2500	824.2500
-	869.2625	824.2625
-	869.2750	824.2750
-	869.2875	824.2875
-	869.3000	824.3000
-	869.3125	824.3125
-	869.3250	824.3250
-	869.3375	824.3375
-	869.3500	824.3500
-	869.3625	824.3625
-	869.3750	824.3750

FCC Chan. No. [1]	Mobile Rx Freq.	Mobile Tx Freq
----------------------	--------------------	-------------------

-	869.3875	824.3875
-	869.4000	824.4000
-	869.4125	824.4125
-	869.4250	824.4250
-	869.4375	824.4375
-	869.4500	824.4500
-	869.4625	824.4625
-	869.4750	824.4750
-	869.4875	824.4875
-	869.5000	824.5000
-	869.5125	824.5125
-	869.5250	824.5250
-	869.5375	824.5375
-	869.5500	824.5500
-	869.5625	824.5625
-	869.5750	824.5750
-	869.5875	824.5875
-	869.6000	824.6000
-	869.6125	824.6125
-	869.6250	824.6250
-	869.6375	824.6375
-	869.6500	824.6500
-	869.6625	824.6625
-	869.6750	824.6750
-	869.6875	824.6875

FCC Chan. No. [1]	Mobile Rx Freq	Mobile Tx Freq
----------------------	-------------------	-------------------

-	869.7000	824.7000
-	869.7125	824.7125
-	869.7250	824.7250
-	869.7375	824.7375
-	869.7500	824.7500
-	869.7625	824.7625
-	869.7750	824.7750
-	869.7875	824.7875
-	869.8000	824.8000
-	869.8125	824.8125
-	869.8250	824.8250
-	869.8375	824.8375
-	869.8500	824.8500
-	869.8625	824.8625
-	869.8750	824.8750
-	869.8875	824.8875
-	869.9000	824.9000
-	869.9125	824.9125
-	869.9250	824.9250
-	869.9375	824.9375
-	869.9500	824.9500
-	869.9625	824.9625
-	869.9750	824.9750
-	869.9875	824.9875

[1] Do not use the FCC channel number to program a channel. Use the channel number from the channel table selected by pressing F6 in the Main Radio Parameters screen (see Section 4.7.2).

## 900 MHz Channels

FCC Chan. No. [1]	Mobile Rx Freq.	Mobile Tx Freq	FCC Chan. No. [1]	Mobile Rx Freq.	Mobile Tx Freq	FCC Chan. No. [1]	Mobile Rx Freq	Mobile Tx Freq
1	935.0125	896.0125	48	935.6000	896.6000	95	936.1875	897.1875
2	935.0250	896.0250	49	935.6125	896.6125	96	936.2000	897.2000
3	935.0375	896.0375	50	935.6250	896.6250	97	936.2125	897.2125
4	935.0500	896.0500	51	935.6375	896.6375	98	936.2250	897.2250
5	935.0625	896.0625	52	935.6500	896.6500	99	936.2375	897.2375
6	935.0750	896.0750	53	935.6625	896.6625	100	936.2500	897.2500
7	935.0875	896.0875	54	935.6750	896.6750	101	936.2625	897.2625
8	935.1000	896.1000	55	935.6875	896.6875	102	936.2750	897.2750
9	935.1125	896.1125	56	935.7000	896.7000	103	936.2875	897.2875
10	935.1250	896.1250	57	935.7125	896.7125	104	936.3000	897.3000
11	935.1375	896.1375	58	935.7250	896.7250	105	936.3125	897.3125
12	935.1500	896.1500	59	935.7375	896.7375	106	936.3250	897.3250
13	935.1625	896.1625	60	935.7500	896.7500	107	936.3375	897.3375
14	935.1750	896.1750	61	935.7625	896.7625	108	936.3500	897.3500
15	935.1875	896.1875	62	935.7750	896.7750	109	936.3625	897.3625
16	935.2000	896.2000	63	935.7875	896.7875	110	936.3750	897.3750
17	935.2125	896.2125	64	935.8000	896.8000	111	936.3875	897.3875
18	935.2250	896.2250	65	935.8125	896.8125	112	936.4000	897.4000
19	935.2375	896.2375	66	935.8250	896.8250	113	936.4125	897.4125
20	935.2500	896.2500	67	935.8375	896.8375	114	936.4250	897.4250
21	935.2625	896.2625	68	935.8500	896.8500	115	936.4375	897.4375
22	935.2750	896.2750	69	935.8625	896.8625	116	936.4500	897.4500
23	935.2875	896.2875	70	935.8750	896.8750	117	936.4625	897.4625
24	935.3000	896.3000	71	935.8875	896.8875	118	936.4750	897.4750
25	935.3125	896.3125	72	935.9000	896.9000	119	936.4875	897.4875
26	935.3250	896.3250	73	935.9125	896.9125	120	936.5000	897.5000
27	935.3375	896.3375	74	935.9250	896.9250	121	936.5125	897.5125
28	935.3500	896.3500	75	935.9375	896.9375	122	936.5250	897.5250
29	935.3625	896.3625	76	935.9500	896.9500	123	936.5375	897.5375
30	935.3750	896.3750	77	935.9625	896.9625	124	936.5500	897.5500
31	935.3875	896.3875	78	935.9750	896.9750	125	936.5625	897.5625
32	935.4000	896.4000	79	935.9875	896.9875	126	936.5750	897.5750
33	935.4125	896.4125	80	936.0000	897.0000	127	936.5875	897.5875
34	935.4250	896.4250	81	936.0125	897.0125	128	936.6000	897.6000
35	935.4375	896.4375	82	936.0250	897.0250	129	936.6125	897.6125
36	935.4500	896.4500	83	936.0375	897.0375	130	936.6250	897.6250
37	935.4625	896.4625	84	936.0500	897.0500	131	936.6375	897.6375
38	935.4750	896.4750	85	936.0625	897.0625	132	936.6500	897.6500
39	935.4875	896.4875	86	936.0750	897.0750	133	936.6625	897.6625
40	935.5000	896.5000	87	936.0875	897.0875	134	936.6750	897.6750
41	935.5125	896.5125	88	936.1000	897.1000	135	936.6875	897.6875
42	935.5250	896.5250	89	936.1125	897.1125	136	936.7000	897.7000
43	935.5375	896.5375	90	936.1250	897.1250	137	936.7125	897.7125
44	935.5500	896.5500	91	936.1375	897.1375	138	936.7250	897.7250
45	935.5625	896.5625	92	936.1500	897.1500	139	936.7375	897.7375
46	935.5750	896.5750	93	936.1625	897.1625	140	936.7500	897.7500
47	935.5875	896.5875	94	936.1750	897.1750	141	936.7625	897.7625

[1] Do not use the FCC channel number to program a channel. Use the channel number from the channel table selected by pressing F6 in the Main Radio Parameters screen (see Section 4.7.2).

## 900 MHz Channels

FCC Chan. No. [1]	Mobile Rx Freq.	Mobile Tx Freq	FCC Chan. No. [1]	Mobile Rx Freq.	Mobile Tx Freq	FCC Chan. No. [1]	Mobile Rx Freq	Mobile Tx Freq
142	936.7750	897.7750	189	937.3625	898.3625	236	937.9500	898.9500
143	936.7875	897.7875	190	937.3750	898.3750	237	937.9625	898.9625
144	936.8000	897.8000	191	937.3875	898.3875	238	937.9750	898.9750
145	936.8125	897.8125	192	937.4000	898.4000	239	937.9875	898.9875
146	936.8250	897.8250	193	937.4125	898.4125	240	938.0000	899.0000
147	936.8375	897.8375	194	937.4250	898.4250	241	938.0125	899.0125
148	936.8500	897.8500	195	937.4375	898.4375	242	938.0250	899.0250
149	936.8625	897.8625	196	937.4500	898.4500	243	938.0375	899.0375
150	936.8750	897.8750	197	937.4625	898.4625	244	938.0500	899.0500
151	936.8875	897.8875	198	937.4750	898.4750	245	938.0625	899.0625
152	936.9000	897.9000	199	937.4875	898.4875	246	938.0750	899.0750
153	936.9125	897.9125	200	937.5000	898.5000	247	938.0875	899.0875
154	936.9250	897.9250	201	937.5125	898.5125	248	938.1000	899.1000
155	936.9375	897.9375	202	937.5250	898.5250	249	938.1125	899.1125
156	936.9500	897.9500	203	937.5375	898.5375	250	938.1250	899.1250
157	936.9625	897.9625	204	937.5500	898.5500	251	938.1375	899.1375
158	936.9750	897.9750	205	937.5625	898.5625	252	938.1500	899.1500
159	936.9875	897.9875	206	937.5750	898.5750	253	938.1625	899.1625
160	937.0000	898.0000	207	937.5875	898.5875	254	938.1750	899.1750
161	937.0125	898.0125	208	937.6000	898.6000	255	938.1875	899.1875
162	937.0250	898.0250	209	937.6125	898.6125	256	938.2000	899.2000
163	937.0375	898.0375	210	937.6250	898.6250	257	938.2125	899.2125
164	937.0500	898.0500	211	937.6375	898.6375	258	938.2250	899.2250
165	937.0625	898.0625	212	937.6500	898.6500	259	938.2375	899.2375
166	937.0750	898.0750	213	937.6625	898.6625	260	938.2500	899.2500
167	937.0875	898.0875	214	937.6750	898.6750	261	938.2625	899.2625
168	937.1000	898.1000	215	937.6875	898.6875	262	938.2750	899.2750
169	937.1125	898.1125	216	937.7000	898.7000	263	938.2875	899.2875
170	937.1250	898.1250	217	937.7125	898.7125	264	938.3000	899.3000
171	937.1375	898.1375	218	937.7250	898.7250	265	938.3125	899.3125
172	937.1500	898.1500	219	937.7375	898.7375	266	938.3250	899.3250
173	937.1625	898.1625	220	937.7500	898.7500	267	938.3375	899.3375
174	937.1750	898.1750	221	937.7625	898.7625	268	938.3500	899.3500
175	937.1875	898.1875	222	937.7750	898.7750	269	938.3625	899.3625
176	937.2000	898.2000	223	937.7875	898.7875	270	938.3750	899.3750
177	937.2125	898.2125	224	937.8000	898.8000	271	938.3875	899.3875
178	937.2250	898.2250	225	937.8125	898.8125	272	938.4000	899.4000
179	937.2375	898.2375	226	937.8250	898.8250	273	938.4125	899.4125
180	937.2500	898.2500	227	937.8375	898.8375	274	938.4250	899.4250
181	937.2625	898.2625	228	937.8500	898.8500	275	938.4375	899.4375
182	937.2750	898.2750	229	937.8625	898.8625	276	938.4500	899.4500
183	937.2875	898.2875	230	937.8750	898.8750	277	938.4625	899.4625
184	937.3000	898.3000	231	937.8875	898.8875	278	938.4750	899.4750
185	937.3125	898.3125	232	937.9000	898.9000	279	938.4875	899.4875
186	937.3250	898.3250	233	937.9125	898.9125	280	938.5000	899.5000
187	937.3375	898.3375	234	937.9250	898.9250	281	938.5125	899.5125
188	937.3500	898.3500	235	937.9375	898.9375	282	938.5250	899.5250

[1] Do not use the FCC channel number to program a channel. Use the channel number from the channel table selected by pressing F6 in the Main Radio Parameters screen (see Section 4.7.2).



## 900 MHz Channels

FCC Chan. No. [1]	Mobile Rx Freq.	Mobile Tx Freq	FCC Chan. No. [1]	Mobile Rx Freq.	Mobile Tx Freq	FCC Chan. No. [1]	Mobile Rx Freq	Mobile Tx Freq
283	938.5375	899.5375	330	939.1250	900.1250	377	939.7125	900.7125
284	938.5500	899.5500	331	939.1375	900.1375	378	939.7250	900.7250
285	938.5625	899.5625	332	939.1500	900.1500	379	939.7375	900.7375
286	938.5750	899.5750	333	939.1625	900.1625	380	939.7500	900.7500
287	938.5875	899.5875	334	939.1750	900.1750	381	939.7625	900.7625
288	938.6000	899.6000	335	939.1875	900.1875	382	939.7750	900.7750
289	938.6125	899.6125	336	939.2000	900.2000	383	939.7875	900.7875
290	938.6250	899.6250	337	939.2125	900.2125	384	939.8000	900.8000
291	938.6375	899.6375	338	939.2250	900.2250	385	939.8125	900.8125
292	938.6500	899.6500	339	939.2375	900.2375	386	939.8250	900.8250
293	938.6625	899.6625	340	939.2500	900.2500	387	939.8375	900.8375
294	938.6750	899.6750	341	939.2625	900.2625	388	939.8500	900.8500
295	938.6875	899.6875	342	939.2750	900.2750	389	939.8625	900.8625
296	938.7000	899.7000	343	939.2875	900.2875	390	939.8750	900.8750
297	938.7125	899.7125	344	939.3000	900.3000	391	939.8875	900.8875
298	938.7250	899.7250	345	939.3125	900.3125	392	939.9000	900.9000
299	938.7375	899.7375	346	939.3250	900.3250	393	939.9125	900.9125
300	938.7500	899.7500	347	939.3375	900.3375	394	939.9250	900.9250
301	938.7625	899.7625	348	939.3500	900.3500	395	939.9375	900.9375
302	938.7750	899.7750	349	939.3625	900.3625	396	939.9500	900.9500
303	938.7875	899.7875	350	939.3750	900.3750	397	939.9625	900.9625
304	938.8000	899.8000	351	939.3875	900.3875	398	939.9750	900.9750
305	938.8125	899.8125	352	939.4000	900.4000	399	939.9875	900.9875
306	938.8250	899.8250	353	939.4125	900.4125	400	940.0000	901.0000
307	938.8375	899.8375	354	939.4250	900.4250	401	940.0125	901.0125
308	938.8500	899.8500	355	939.4375	900.4375	402	940.0250	901.0250
309	938.8625	899.8625	356	939.4500	900.4500	403	940.0375	901.0375
310	938.8750	899.8750	357	939.4625	900.4625	404	940.0500	901.0500
311	938.8875	899.8875	358	939.4750	900.4750	405	940.0625	901.0625
312	938.9000	899.9000	359	939.4875	900.4875	406	940.0750	901.0750
313	938.9125	899.9125	360	939.5000	900.5000	407	940.0875	901.0875
314	938.9250	899.9250	361	939.5125	900.5125	408	940.1000	901.1000
315	938.9375	899.9375	362	939.5250	900.5250	409	940.1125	901.1125
316	938.9500	899.9500	363	939.5375	900.5375	410	940.1250	901.1250
317	938.9625	899.9625	364	939.5500	900.5500	411	940.1375	901.1375
318	938.9750	899.9750	365	939.5625	900.5625	412	940.1500	901.1500
319	938.9875	899.9875	366	939.5750	900.5750	413	940.1625	901.1625
320	939.0000	900.0000	367	939.5875	900.5875	414	940.1750	901.1750
321	939.0125	900.0125	368	939.6000	900.6000	415	940.1875	901.1875
322	939.0250	900.0250	369	939.6125	900.6125	416	940.2000	901.2000
323	939.0375	900.0375	370	939.6250	900.6250	417	940.2125	901.2125
324	939.0500	900.0500	371	939.6375	900.6375	418	940.2250	901.2250
325	939.0625	900.0625	372	939.6500	900.6500	419	940.2375	901.2375
326	939.0750	900.0750	373	939.6625	900.6625	420	940.2500	901.2500
327	939.0875	900.0875	374	939.6750	900.6750	421	940.2625	901.2625
328	939.1000	900.1000	375	939.6875	900.6875	422	940.2750	901.2750
329	939.1125	900.1125	376	939.7000	900.7000	423	940.2875	901.2875

[1] Do not use the FCC channel number to program a channel. Use the channel number from the channel table selected by pressing F6 in the Main Radio Parameters screen (see Section 4.7.2).

## 900 MHz Channels

FCC Chan. No. [1]	Mobile Rx Freq.	Mobile Tx Freq
----------------------	--------------------	-------------------

FCC Chan. No. [1]	Mobile Rx Freq.	Mobile Tx Freq
----------------------	--------------------	-------------------

FCC Chan. No. [1]	Mobile Rx Freq	Mobile Tx Freq
----------------------	-------------------	-------------------

424	940.3000	901.3000	443	940.5375	901.5375	462	940.7750	901.7750
425	940.3125	901.3125	444	940.5500	901.5500	463	940.7875	901.7875
426	940.3250	901.3250	445	940.5625	901.5625	464	940.8000	901.8000
427	940.3375	901.3375	446	940.5750	901.5750	465	940.8125	901.8125
428	940.3500	901.3500	447	940.5875	901.5875	466	940.8250	901.8250
429	940.3625	901.3625	448	940.6000	901.6000	467	940.8375	901.8375
430	940.3750	901.3750	449	940.6125	901.6125	468	940.8500	901.8500
431	940.3875	901.3875	450	940.6250	901.6250	469	940.8625	901.8625
432	940.4000	901.4000	451	940.6375	901.6375	470	940.8750	901.8750
433	940.4125	901.4125	452	940.6500	901.6500	471	940.8875	901.8875
434	940.4250	901.4250	453	940.6625	901.6625	472	940.9000	901.9000
435	940.4375	901.4375	454	940.6750	901.6750	473	940.9125	901.9125
436	940.4500	901.4500	455	940.6875	901.6875	474	940.9250	901.9250
437	940.4625	901.4625	456	940.7000	901.7000	475	940.9375	901.9375
438	940.4750	901.4750	457	940.7125	901.7125	476	940.9500	901.9500
439	940.4875	901.4875	458	940.7250	901.7250	477	940.9625	901.9625
440	940.5000	901.5000	459	940.7375	901.7375	478	940.9750	901.9750
441	940.5125	901.5125	460	940.7500	901.7500	479	940.9875	901.9875
442	940.5250	901.5250	461	940.7625	901.7625			

[1] Do not use the FCC channel number to program a channel. Use the channel number from the channel table selected by pressing F6 in the Main Radio Parameters screen (see Section 4.7.2).

## SECTION 5 CIRCUIT DESCRIPTION

### 5.1 GENERAL TRANSCEIVER DESCRIPTION

#### 5.1.1 INTRODUCTION

*NOTE: A block diagram of the audio and data processing circuitry on the audio/logic board is located in Figure 5-3, and block diagrams of the RF boards are located in Figures 5-4 and 5-7.*

The 9800-series transceivers contain the PC board assemblies listed below. Components are mounted on only the top side of all boards. Therefore, most components can be changed without removing the board from the chassis.

**Audio/Logic** - Control logic and audio processing.

**Display** - With low tier models, this board contains LED display and driver, key switches, and encoder. With high tier models, it contains the LCD display and controller and interface microcontroller.

**Interface** - This small board is used in high tier models only. It provides the electrical connections between the display and audio/logic boards, and contains the front panel rotary controls and microphone jack.

**RF Board** - Receiver, synthesizer, and exciter.

**PA Board** - Transmitter power amplifier.

General descriptions of the main sections such as the receiver, synthesizer, and exciter follow, and detailed descriptions are located in later sections.

#### 5.1.2 CIRCUIT PROTECTION (FUSES)

Circuit protection is provided by a 15-ampere in-line power cable fuse, 4-ampere fuse F500 on the RF board (in the unswitched battery supply line from the PA board), and by voltage regulators which automatically limit current. The 15-ampere power cable fuse protects the power amplifier module and final stages on the power amplifier board, and the 4-ampere fuse protects the remainder of the circuitry. In addition, there are two fuses on the audio/logic board. One fuse

(F100, 2A) limits the current of the switched battery supply fed to accessory connector J101, the microphone jack, and also the display board (mid/high tier only). The other fuse (F300, 0.6A) limits the current of the 8-volt supply fed to modem jack J301. For information on power distribution and switching, refer to Section 5.2.

#### 5.1.3 SYNTHESIZER

The synthesizer output signal is the transmit frequency in the transmit mode and the receive first injection frequency in the receive mode. The synthesizer also provides the receiver second injection signal by tripling the TCXO frequency.

Channels are selected by programming the main divider in synthesizer integrated circuit U804 to divide by a certain number. This programming is provided by microcontroller U101 on the audio/logic board. The minimum frequency resolution is 6.25 or 10 kHz. The frequency stability of the synthesizer is determined by the stability of TCXO U806 (Temperature Compensated Crystal Oscillator). The TCXO has a frequency stability of  $\pm 2.0$  PPM (UHF) or  $\pm 1.5$  PPM (800/900 MHz) from  $-22^{\circ}$  to  $+140^{\circ}$  F ( $-30$  to  $+60^{\circ}$  C).

#### 5.1.4 AUDIO/LOGIC BOARD

Microcontroller U101 on the audio/logic board provides transceiver control functions including synthesizer programming, system and group scan, data encoding and decoding, squelch, and gating of audio and data signals. The audio/logic board also has analog circuitry which provides filtering, amplification, and other processing of the audio, data, and Call Guard signals.

The U101 operating program is stored in Flash EPROM U108. This type of memory can be reprogrammed in the field using the standard programming setup and special programming software. This allows the operating software to be easily updated without the need to change a microprocessor or EPROM. Flash EPROM memory devices retain data indefinitely without the need for battery backup, and can be reprogrammed many times.

## POWER DISTRIBUTION (ALL MODELS)

Parameters which change from transceiver to transceiver such as programmed system and groups and option key programming are also stored in the Flash EPROM and also EEPROM U102 which is used only in high tier and data models. This information is programmed when data is downloaded to the transceiver by the programming software described in Section 4.

With high tier models, a second microcontroller (U2) on the display board controls the front panel display and tri-color indicator and also detects the option switch, Select switch, and microphone on/off hook state. Control information is exchanged between U101 and this microcontroller via a serial bus. The use of a second microcontroller minimizes the number of interconnections that are required between the audio/logic and display boards. The operating program for this microcontroller is permanently stored on the chip and cannot be changed.

### 5.1.5 RECEIVER

The receiver is a double conversion type with the following intermediate frequencies:

- UHF Models - 45 MHz and 450 kHz
- 800 MHz Models - 52.950 MHz and 450 kHz
- 900 MHz Models - 45 MHz and 450 kHz

Two bandpass filters in the front end attenuate the image, half IF, injection, and other frequencies outside the selected receive band. Receiver selectivity is enhanced by a four-pole crystal filter and two 450 kHz ceramic filters.

### 5.1.6 TRANSMITTER

The transmitter amplifies the synthesizer signal to produce a power output of up to either 25 or 40 watts (UHF) or 15 or 30 watts (800/900 MHz) at the antenna jack. Frequency modulation of the transmit signal is performed by modulating the synthesizer TCXO and VCO frequencies. A control circuit senses forward power to maintain constant power output. It also senses final amplifier current and cuts back power if it becomes excessive. The use of a digital potentiometer allows the power output to be set from the front panel when the test mode is selected and also allows two different power levels to be programmed

for each system. The microcontroller also monitors power amplifier ambient temperature and voltage and cuts back power or disables the transmitter if either are excessive.

## 5.2 POWER DISTRIBUTION AND SWITCHING

### 5.2.1 POWER SWITCHING CONTROL

A diagram of the power distribution and switching circuits is shown in Figure 5-1. The main power switching is performed on the RF board by Q510 and other transistors. This switch is controlled by the front panel power switch, the ignition sense input, and the microcontroller as shown in Figure 5-2. For the front panel on-off switch to be detected, Q109 must be turned on by a high signal applied through R170 or from the ignition switch. R170 is installed if the ignition switch is not used to control power. Q107 and Q108 provide power switch on and ignition on signals to the microcontroller so that it can sense those conditions.

Q110 allows the microcontroller to hold power on for a time after it has been turned off by the power or ignition switch. For example, when the microcontroller senses that power was switched off by the front panel switch, it holds power on for a short time so that switch settings can be saved to memory. It also holds power on when a power-off delay is used. Once power turns off, power is also removed from the microcontroller. Therefore, power can be turned on only by the power and ignition switches.

*NOTE: The front panel power switch of low tier models is a momentary push-button type, and the power switch of high tier models is a push on, push off type (pressing it toggles between open and closed). It is not a momentary switch like low tier models.*

### 5.2.2 SUPPLY SWITCHING

#### Low Tier On-Off Toggle

Since low tier models have a momentary-type power switch, a latch is required to hold power on after the switch is released. When the power switch is pressed, the base of Q113 on the audio/logic board is

POWER DISTRIBUTION (ALL MODELS)

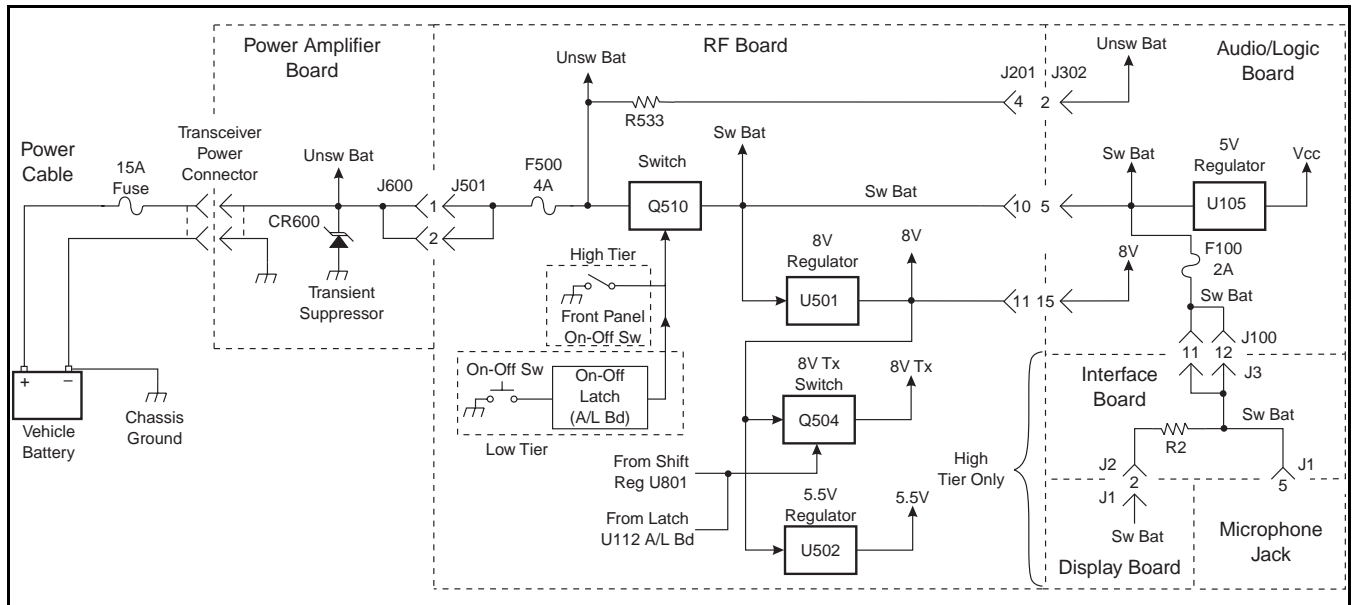

Figure 5-1 Power Distribution and Switching

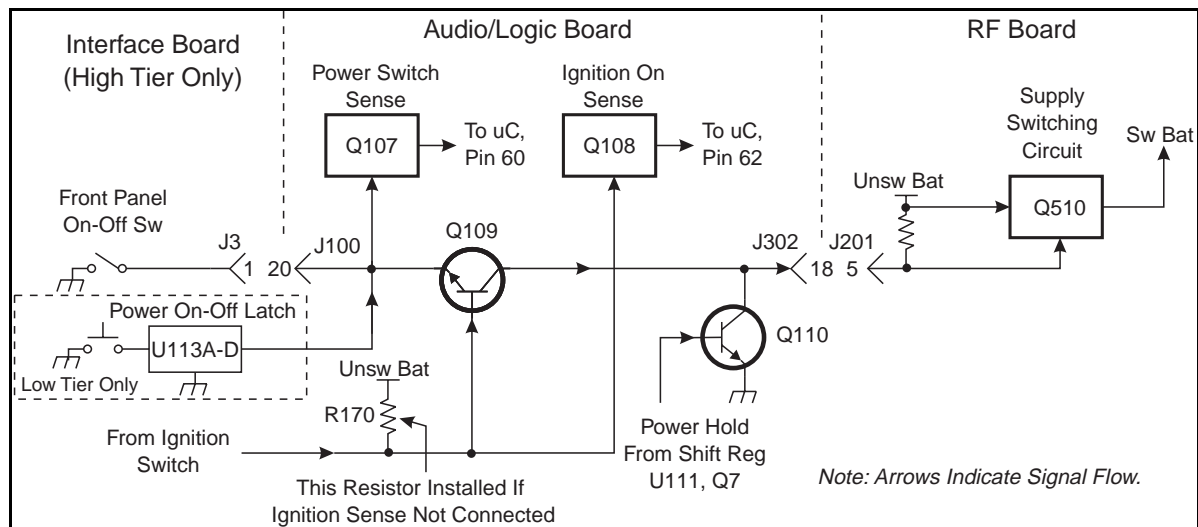

Figure 5-2 Power On-Off Control Circuit

grounded which turns that transistor on. C125 then charges through R185 and applies a high pulse to pins 2 and 4 of NAND gate U113. Then when the switch is released, Q113 turns off and C125 discharges through R183-R185.

The latch is formed by NAND gates U113A-D. The outputs of gates U113C and U113D are always the opposite state and are fed back to an input of U113A

and U113B (pins 1 and 5). Therefore, pins 1 and 5 are always the opposite state. When the power switch is pressed, the output of the gate with a logic high applied goes low (the other gate does not change states). This toggles the outputs of U113C and U113D. When power is turned on, the output on pin 8 goes high and Q309 is turned on by the current flowing through R189. Q114 then turns on and grounds the emitter of Q109. When power is turned off, the opposite occurs.

## AUDIO/LOGIC DESCRIPTION (ALL MODELS)

RC networks R186/C124 and R187/C126 have a longer time constant than R185/C125 so that the new logic level applied to pins 1 and 5 is delayed for at least the duration of the high pulse applied to pins 2 and 4. This prevents oscillation. Q112 provides a 5-volt supply to the latch. C123 stores enough power to provide supply voltage to the latch for up to a week. Therefore, if power is removed from the transceiver, such as by a relay used to switch power, the on-off mode is the same mode when power is reapplied.

### Supply Switching on RF Board

When power is turned on by the front panel power switch, the base of Q514 on the RF board is grounded through Q109 on the audio/logic board by Q114 (low tier) or the power switch (high tier). Q514 then turns on which also turns on the Darlington amplifier formed by Q511 and Q512. These transistors are turned on by a 13.6-volt signal applied through R535. Series-pass transistor Q510 is then turned on and 13 volts appears on its collector. The diodes in CR505 and CR506 become forward biased only if the 8-volt supply applied to the collector of Q514 becomes shorted. This provides current limiting which prevents damage to the transistors.

Q513 controls the Q511 base current in order to maintain approximately a 0.8-volt drop across the emitter and collector of Q510. This provides noise filtering of the 13.6-volt supply. The emitter of Q513 is biased at about 4.5 volts by R538 and R542 (with a battery voltage of 13.6 volts). CR504 mirrors the base-emitter voltage of Q513, and the voltage across R541 is the same as the voltage across R542 when the voltage applied to R536 is approximately 12.8 volts.

Noise pulses less than 1.6 volt P-P then do not appear on the output of Q510 because of the emitter voltage filtering provided by C565. This reduces the amount of noise applied to circuits powered by the switched 13.6-volt supply such as audio power amplifier U306. Additional filtering of the switched and unswitched battery supplies is provided by C548-C553. Resistor R534 turns Q514 off when power is turned off.

## 5.3 AUDIO/LOGIC BOARD DIGITAL CIRCUIT

### 5.3.1 MICROCONTROLLER (U101)

#### General

The control logic is based on an MC68HC11F1 eight-bit microcontroller (U101). This device has an internal 1K-byte static RAM and 512-byte EEPROM but no internal ROM or EEPROM. Therefore, all program memory is contained in the external flash memory device (U108). In addition, the microcontroller has several general purpose input and output pins, an eight-channel A/D converter, and synchronous (SPI) and asynchronous (SCI) serial ports. The A/D converter port allows analog signals to be monitored such as the power amplifier temperature, RSSI signal, and vehicle battery voltage.

Separate buses are used for data and memory addressing. The data bus consists of D0-D7, and the address bus consists of A0-A15. The operating speed of the microcontroller is set by crystal Y100. The 9.38 MHz frequency of this crystal is divided by an internal divider to produce a lower internal operating frequency.

#### Memory

The operating program and most of the personality information used by the microcontroller is stored in 128K x 8 Flash EPROM U108. The use of a Flash memory device allows the program to be conveniently updated using the standard programming setup and special Flash programming software. This eliminates the need to replace the microcontroller or a memory device such as an EPROM. To reprogram the Flash device, the microcontroller is placed in a special bootstrap mode by turning power on with the MODA/MODB inputs pulled low. This is done by the RPI by applying 20 volts to the PTT pin of the microphone jack.

Radio tuning information is stored in the 512-byte EEPROM in microcontroller U101. External 4K x 8 EEPROM U102 is used in high tier and data models to store additional personality information. An EEPROM can be programmed many times, does not require a constant power supply, and retains data indefinitely.

## AUDIO/LOGIC DESCRIPTION (ALL MODELS)

Temporary data storage is provided by an internal 1K x 8 RAM in microcontroller U101 and with high tier and data models, by external 8K x 8 RAM U107. These devices are used as a “scratchpad” during program execution.

### Reset

The microcontroller resets when power is turned on and also when the 5-volt supply drops below the normal range. Reset clears several internal registers and restarts the operating program. This prevents improper operation which may result during low - voltage conditions.

The microcontroller resets itself automatically for 4064 clock cycles when power is applied to the VCC input. Low-voltage reset is triggered by low-voltage sensor U100. When the 5-volt supply drops to approximately 4.25 volts, the RESET output goes low. This resets the microcontroller and also inhibits operation for as long as it is low. The microcontroller also has internal reset circuits which trigger reset if problems occur with the clock signal, illegal op codes, or the watchdog timer circuit.

Reset is also triggered when the transceiver is Flash programmed. A low pulse is created by C363 and R421 when the MODA/MODB inputs of the microcontroller are pulled low to initiate this programming. This automatically places the microcontroller in the flash programming mode. However, reset does not occur when flash programming is complete, so power must be turned off and then on again to resume normal operation.

### Data Bus

A bi-directional data bus consisting of D0-D7 is used to transfer data in and out of the microcontroller. It is used to transfer parallel data in and out of memory chips U107 (high tier only) and U108, and also program latches U110-U112. The logic level on the R/W pin determines the direction of data on the data bus. If it is high, data is read into U101, and if it is low, data is written out. The E output goes high to indicate when data on the data bus is valid or when an external device can place data on the data bus.

### Address Bus

The address bus consisting of A0-A15 is used for addressing the memory location in U107 or U108 that data is being written to or read from. In addition, it provides chip select signals to latches U110-U112. Refer to Section 5.3.2 for more information on memory and I/O addressing.

### A/D Converter Inputs

**VRH/VRL** - These inputs provide the reference voltages for the A/D converter circuitry. R115 and C105 attenuate noise present in the 5-volt supply applied to VRH.

**PE0** - RSSI (Receive Signal Strength Indicator) input from limiter/detector U201 in the receiver. This signal is used along with the squelch signal to determine when valid data may be present and when to unmute the receive audio.

**PE1** - Battery voltage input. The switched 13.6-volt supply is divided down by R161 and R168 to provide a 0-5 volt input. If the battery voltage is excessively high, the transmitter is disabled.

**PE2** - Power amplifier temperature input from thermistor R601 on the PA board. The DC voltage of this signal decreases as temperature increases.

**PE3** - Lock detect input from synthesizer IC U804. If this signal is high (near 5 volts) the synthesizer is locked on frequency (see Section 5.7.6).

**PE4** - Power switch sense input. This input is high when the power switch is on and low when it is off. When the off condition is sensed, the microcontroller saves the current settings and then powers down the transceiver by turning Q110 off (see Section 5.2.1).

**PE5** - Ignition switch sense input. This input is low when the ignition switch is on and high when it is off. The microcontroller senses the ignition switch to control such features as the power-off delay and horn alert.

**PE6** - This input senses the voltage on the IN2 pin of data modem connector J301 and Option 2 slot wire-out W311.

## AUDIO/LOGIC DESCRIPTION (ALL MODELS)

**PE7** - This input senses the voltage on the IN3 pin of Option 1 slot wire-out W301.

### Serial Peripheral Interface Port (SPI), OR Gate (U103)

This serial port is formed by the MOSI, MISO, and SCK pins (31, 30, 32) of the microcontroller. It is a synchronous port which means that a clock signal is used to indicate when data on the data line is valid. This port has both master and slave configurations and in this application, the master configuration is always used. In the master configuration the microcontroller generates the clock and other signals.

**MOSI (Master Out, Slave In)** - This is the serial data output for the port.

**MISO (Master In, Slave Out)** - This is the serial data input for this port.

**SCK** - Serial clock output. This pin provides the clock signal to all devices served by this port.

This port provides two-way serial data communication with EEPROM U102 (high tier and data models) and microcontroller U2 on the display board (high tier only). In addition, it provides programming data to the RF board for shift registers U800 and U801, digital potentiometer U802, and synthesizer IC U804 (see Section 5.7.8). It also provides programming data to shift register U305 (on the audio/logic board) which controls the squelch level.

OR gates U103A-D provide routing of the serial port signals to the RF and display boards. When the PD5 output (pin 33) of the microcontroller goes low, U103A and U103B route the data and clock signals to the RF board and shift register U305. Then when the Q4 output (pin 15) of latch U110 goes low, U103D routes the clock signal to the display board and U103C routes the display board data signal to the MISO pin. When communicating with the display board, PD5 goes high to block the data path through U103A and U103B.

### Asynchronous Serial Communications Interface (SCI)

This is a full duplex serial port formed by the RxD (data input) and TxD (data output) pins (28, 29) of the microcontroller. This port uses a standard non-

return-to-zero (NRZ) format consisting of one start bit, eight or nine data bits, and one stop bit.

This port is used to provide data communication with the computer used to program the transceiver. Connection is made via the front panel microphone connector. Another use for this port is data communication with an external data device such as a modem. Connection is made via connector J301. Communication cannot occur simultaneously over both of these paths.

### Other General Purpose Inputs and Outputs

The PA0-PA7 pins are used for general purpose inputs and outputs as follows:

**PA0** - Input for PTT signal from the microphone jack and W302/W312 option slot wire-outs. This signal is low when the transmitter is keyed.

**PA1** - Input for the receive LTR or Call Guard data signal.

**PA2** - Service request input from microcontroller U2 on the display board. This tells U101 that it has data to send on the SPI bus described previously.

**PA3** - Input from the Option 1 pin of modem connector J301.

**PA4/PA5** - Transmit LTR/Call Guard data output. These two outputs are used to create a pseudo sine-wave signal. See Section 5.5.4 for more information.

**PA6** - Output for supervisory tones generated by the microcontroller such as busy and out-of-range.

**PA7** - Input from the squelch circuit (see Section 5.4.4). When the received signal strength increases to the squelch threshold level, this input goes high. The microcontroller uses this information to determine when receive data is valid and to control audio muting.

## 5.3.2 MEMORY AND LATCH PROGRAMMING

### RAM U107 (High Tier and Data Models)

When a data read or write to U107 occurs, the location in U107 is selected by address lines A0-A12,



## AUDIO/LOGIC DESCRIPTION (ALL MODELS)

and the data appears on data bus lines D0-D7. Chip select is performed by pulling the CE1 input (pin 20) low. The CE2 input is always pulled high by R114. The A13 and A14 address lines can be connected by changing jumpers if a 16K or 32K part is required. Data is read from U107 by pulling the OE input (pin 22) low. Likewise, data is written by pulling the WE input (pin 27) low. See the U104 description which follows for more information.

### Flash EPROM (U108)

As described in Section 5.3.1, U108 can store up to 128K bytes of data. The memory space is arranged as 32K of common code space and twelve 8K blocks of bank code space. The A15 line of the microcontroller determines if common or bank code space is selected. When A15 is high, common space is selected, and when it is low, bank space is selected.

The A15 line controls the four two-input multiplexers in U109. When A15 is low, the A input is connected to Y which routes the PG0-PG3 outputs of the microcontroller to U108. PG0-PG3 then select the desired bank. Then when A15 is high, the B input is routed to Y and the A13-A15 address lines of the microcontroller are routed to U108.

Therefore, when a data read or write to U108 occurs, the lower 13 bits of the address are specified by address lines A0-A12 and the rest of the address is specified as just described. The data appears on data bus lines D0-D7. Data is read from U108 by pulling the  $\overline{OE}$  input (pin 24) low, and data is written by pulling the  $\overline{WE}$  input (pin 31) low. Refer to the following U104 description for more information. Chip select is provided by pulling the  $\overline{CE}$  input (pin 22) low.

### Read/Write Strobe Select (U104A-D)

NAND gates U104C and U104B select the read and write signals applied to U107 and U108. When a memory read occurs, the  $R/\overline{W}$  output of the microcontroller goes high. This signal is inverted by U104C and applied to the  $\overline{OE}$  of U108. When a memory write operation occurs, the  $R/\overline{W}$  output of the microcontroller goes low. U104B is then enabled by the high output of U104C, and the high E signal is inverted by U104B and applied to the  $\overline{WE}$  pin of U107 and to U104D.

NAND gates U104A and U104D provide gating of the write signal to U108. Data is written to this device only during Flash programming. Therefore, when Flash programming occurs, the Q3 output (pin 16) of shift register U111 goes high which enables U104A. A double inversion of the write signal then occurs and it is applied to the  $\overline{WE}$  input of U108.

### Latch Programming (U106, U110-U112)

Decoder U106 provides chip select to octal latches U110, U111, and U112. When data is written to U106 address space, a low signal is applied to chip select input  $\overline{G2A}$  (pin 4) and a high signal is applied to chip select input G1 (pin 6). The three address bits applied to the A, B, and C inputs of U106 select one of the eight outputs. When an output is selected, it goes low.

Data is latched by U110-U112 on a rising edge of a clock signal from U106. Therefore, when the U106 output is disabled, data is latched. The outputs of the latches are enabled when the  $\overline{OC}$  input (pin 1) is low, and the outputs are a high impedance state when it is high.

## 5.4 RECEIVE AUDIO/DATA PROCESSING

*NOTE: A block diagram of the audio and data processing circuitry is shown in Figure 5-3.*

### 5.4.1 AMPLIFIER (U301B)

The demodulated receive audio/data signal from limiter/detector U201 in the receiver is applied to amplifier U301B. The gain of this amplifier is controlled by analog switch U307B. The gain is higher for narrow-band (12.5 kHz) channels to compensate for the lower detected signal level that results from the lower deviation used with those channels. The gain is approximately four with narrowband channels and two with wideband (25 kHz) channels.

The control input of U307B (pin 5) is low for narrowband channels and high for wideband channels. When it is high, the switch is closed and R327 is switched into the circuit. This adds more feedback which decreases the gain. The control signal comes from the Q0 output (pin 19) of latch U111. Transistor Q305 inverts this signal and also provides level

## AUDIO/LOGIC DESCRIPTION (ALL MODELS)

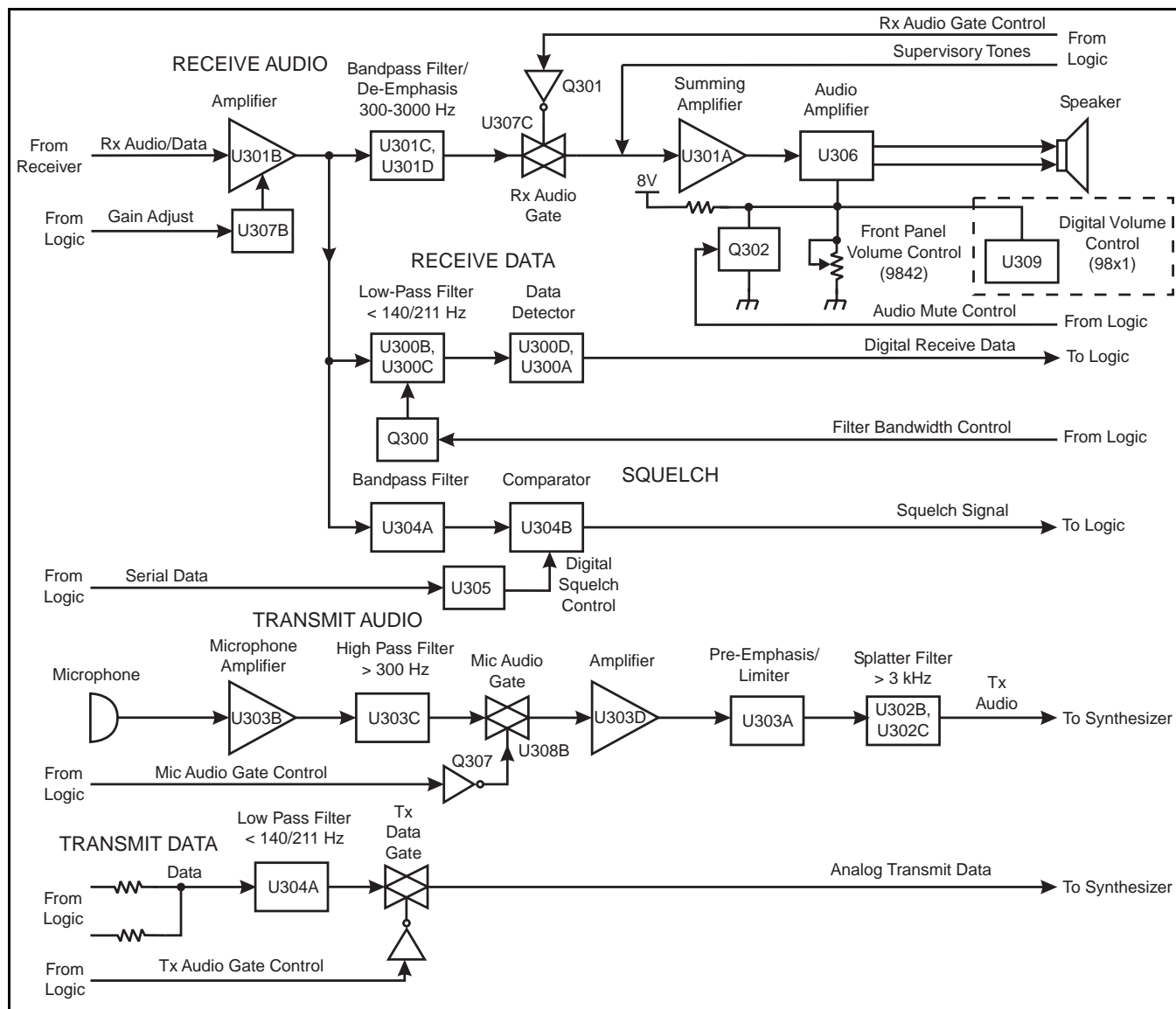

**Figure 5-3 Audio and Data Processing Circuitry Block Diagram**

translation from 5-volt logic levels of U111 to the 8-volt logic levels of U307B.

From U301B the receive audio/data signal is fed to audio, data, and squelch circuits. Refer to the following descriptions for more information.

#### 5.4.2 RECEIVE AUDIO PROCESSING

##### Bandpass Filter (U301C, U301D)

U301C and U301D form a bandpass filter which passes frequencies in the 300-3000 Hz range. This

attenuates frequencies below 300 Hz such as LTR data and Call Guard signaling, and frequencies above 3 kHz such as noise. These stages also provide 6 dB per octave de-emphasis to remove the pre-emphasis that was added to the signal when it was transmitted.

##### Mute Gate (U307C), Summing Amplifier (U301A)

The receive audio signal is then routed via the option wireouts to mute gate U307C. This gate mutes the signal when no carrier is being received or if the message is intended for someone else. It is controlled by the Q5 output (pin 14) of latch U110. When the

## AUDIO/LOGIC DESCRIPTION (ALL MODELS)

audio signal is muted, this output is high. This signal is then inverted by Q301 resulting in a low signal on the control input (pin 6) of gate U307C.

U301A is a summing amplifier which combines the supervisory tone signal from microcontroller pin 36 (PA6) with the receive audio signal. Supervisory tones include the busy and intercept tones and other beeps that are heard by the user. C320 provides additional feedback of the higher frequencies present in the square-wave output of the microcontroller. C323 and R352 also provide shaping of this signal.

### Audio Power Amplifier (U306)

The output signal from U301A is fed to the microphone connector through C321 and to audio power amplifier U306. This is a 5-watt (with an 8-ohm load) bridge-type amplifier. Therefore, both outputs are connected directly to the speaker and neither speaker terminal is grounded. This device is internally protected from damage resulting from shorting either output to ground or B+, or shorting across the outputs.

Pin 5 is the input of an internal gain control stage. Gain increases in proportion to increases in the DC voltage on this pin. With the low tier models, volume control is provided by a D/A converter formed by shift register U309 and several resistors. The six-bit output controls the volume in 64 steps. U309 is programmed by the SPI bus described in Section 5.3.1. With the mid and high tier models, the front panel volume control is part of a voltage divider which includes R356 and R426.

If the voltage on pin 5 falls below approximately 0.4 volt DC, the output is muted. Speaker muting is controlled by the Q7 output (pin 12) of latch U110. When this output goes high, inverter/level translator Q302 turns on which grounds the volume control input of U306 and mutes the speaker.

### 5.4.3 RECEIVE DATA PROCESSING

The receive audio/data signal from amplifier U301B is applied to a low-pass filter formed by U300B and U300C. This filter attenuates voice and harmonic frequencies occurring above the data band.

The passband of this filter is controlled by the Q1 output (pin 18) of latch U111. When LTR or digital Call Guard data or low-frequency Call Guard tones are received, this output goes high which turns Q300 on. This switches additional capacitance into the circuit and the filter cut-off frequency decreases to approximately 150 Hz. Then when high-frequency Call Guard tones are received, the output goes low and turns Q300 off. This increases the cut-off frequency to approximately 220 Hz.

From U300C the data signal is fed to a DC restoration circuit formed by U300D and U300A. This circuit converts it from an analog signal floating at half supply to a digital signal at 0 and 5 volt levels that can be detected by the microcontroller. U300D is a standard noninverting amplifier with a gain set by R308, R316, and R317 (R317 is AC grounded by C309).

Two attenuation levels are selected by gate U307D similar to gate U307B described in Section 5.4.1. When wideband (25 kHz) channels are selected, the control input (pin 12) of U307D is high and R317 is effectively shorted which increases gain. The gain of U300D is approximately 3 with wideband channels and 2 with narrow-band channels. This compensates for excess amplification of the data signal in the narrowband mode by U301B.

The CR301 diodes charge and discharge C309 to establish a DC reference on pin 2 of comparator U300A. This reference voltage is the average of the positive and negative alternations of the data signal. When pin 3 of U300A rises above the reference on pin 2, the output goes high (8 volts) and vice versa. Voltage divider R304/R311 provides the 5-volt level required by the microcontroller.

### 5.4.4 SQUELCH CIRCUIT (U304A, U304B)

The microcontroller uses the output from the squelch circuit and also the RSSI output of the limiter/detector (see Section 5.8.4) to determine when to mute and unmute the receive audio and also when valid data may be present. The squelch circuit is controlled by the amount of noise present in the receive audio signal. When no signal or a weak signal is being received, there is a large amount of noise present. Conversely, when a strong signal is received, there is very little noise present.

## AUDIO/LOGIC DESCRIPTION (ALL MODELS)

The receive audio, data, and noise signal from amplifier U301B is applied to a bandpass filter and amplifier formed by U304A and other components. This stage attenuates voice frequencies and LTR and Call Guard signaling so that only noise frequencies in the range of approximately 7-8 kHz are passed. The output signal of U304A is applied across a resistor network which sets the input level to a rectifier. Thermistor R318 provides temperature compensation of this network.

C304 charges through the forward biased diode in CR300 and discharges through R306. C303 discharges through the other diode in CR300. When the voltage on pin 6 of comparator U304B rises above the reference on pin 5, the output goes low. For example, when received signal strength is low, more noise is rectified which causes the voltage on pin 6 of U304B to increase and the output on pin 7 to go low (squelled condition). A voltage divider formed by R416 and R417 reduces the 8-volt output of U304B to the 5-volt level required by the microcontroller.

The squelch threshold level is set by a D/A converter formed by shift register U305 and several resistors. The eight-bit output of U305 can control the reference voltage applied to U304B in 256 steps. U305 is programmed by the SPI serial port described in Section 5.3.1. R310 provides hysteresis to the threshold level to prevent intermittent squelching when receiving a weak or fading signal.

### 5.5 TRANSMIT AUDIO/DATA PROCESSING

*NOTE: A block diagram of the audio and data processing circuitry is shown in Figure 5-3.*

#### 5.5.1 MICROPHONE AMPLIFIER (U303B), HIGH-PASS FILTER (U303C)

The microphone audio signal is coupled by C349 to amplifier U303B which provides a gain of approximately two. R410, R414, and C354 provide a bias voltage of approximately 3.2 volts on the noninverting input. An 8-volt supply voltage to the microphone amplifier is provided by R401, C348, and R406.

From U303B the microphone signal is coupled by C350 to a high-pass filter formed by U303C and

several other components. This filter attenuates frequencies below 300 Hz that could cause interference with LTR data and Call Guard signals.

Gate U308B blocks the microphone signal when microphone audio is not transmitted such as during the data handshake to set up the call. A high signal on pin 5 closes the gate and passes the signal. This gate is controlled by the Q6 output (pin 13) of latch U110. Transistor Q307 functions as an inverter and level translator.

#### 5.5.2 SUMMING AMPLIFIER (U303D), PRE-EMPHASIS/LIMITER (U303A)

U303D amplifies the transmit audio signal and also the transmit data signal from an optional modem if one is used. Jumper R398 is installed to route the modem signal to U303D and the filtering circuitry, or jumper R399 is installed to route a wideband signal directly to the synthesizer so that it bypasses the filtering circuitry. U308A closes when wideband (25 kHz) channels are selected. This bypasses R403 which provides a higher deviation level with those channels.

*NOTE: If the wideband data input is used, the external device must provide FCC-approved modulation limiting and splatter filter circuitry and a stable DC level.*

The output signal from U303D is then routed via the option wireouts to U303A which provides limiting and 6 dB per octave pre-emphasis. This stage is an amplifier which limits by saturating. Limiting prevents over-modulation caused by high-level input signals. R370 and R378 set the input level to the next stage, and C334 provides DC blocking.

#### 5.5.3 SPLATTER FILTER (U302B, U302C)

U302B and U302C form a five-pole, low-pass splatter filter which attenuates frequencies above 3 kHz. This prevents adjacent channel interference. Frequencies over 3 kHz may be produced if limiting occurs in the limiter stage just described. The signal is then fed to digital potentiometer U802 on the RF board which sets the deviation level. Refer to Section 5.7.4 for more information.

## DISPLAY DESCRIPTION

### 5.5.4 TRANSMIT DATA CIRCUIT (U302D, U302A)

The transmit LTR data and Call Guard tone/data signals are generated by the microcontroller on pins 37 and 38. The four logic combinations possible with these two outputs are applied to a resistor network consisting of R389, R392, R386, and R395. This network creates a four-step pseudo sine wave from the digital outputs. This signal is applied to a low-pass filter formed by U302D and U302A. This filter attenuates harmonics present in the signal which provides smoothing of the stepped sine wave.

The passband of this filter is controlled by Q306 which switches additional capacitance into the circuit. When LTR or digital Call Guard data or low-frequency tone Call Guard signaling is being transmitted, Q306 is turned on and the cut-off frequency decreases to approximately 150 Hz. Then when a high-frequency tone Call Guard signal is being transmitted, Q306 is turned off and the cut-off frequency increases to approximately 220 Hz. Q306 is controlled by the same signal used to control Q300 in the receive data circuit (see Section 5.4.3).

U308C provides gating of the transmit data signal. When the control input (pin 6) is high, the gate is closed and the signal is passed. Test gate U307A is used in the test mode to bypass the data filter to provide the wideband data signal required for setting modulation balance. Q303 and Q308 provide level translation and inversion. The transmit data signal is then fed to digital potentiometer U802 on the RF board which sets the data deviation level. Refer to Section 5.7.4 for more information.

## 5.6 DISPLAY BOARDS

### Low Tier Display Board

The low tier display board contains a 1.5-digit LED display and driver circuit and also circuitry which converts key press information into serial data. Display DS1 is a standard seven-segment display with decimal point. Display DS2 has only “b” and “c” segments to display “1” and also decimal point, “+”, and “-” indicators. The common cathode of the internal LEDs is pins 1 and 6.

Display driver U2 controls displays DS1 and DS2 and also LEDs CR1-CR3. Display data is loaded into U2 serially on the Data line (pin 5). It is clocked in by a high-to-low transition on the Clock line (pin 15). The data is latched when the Enable line (pin 14) goes high.

Since several devices are controlled by the same output lines of U2, the display is multiplexed which means that DS2, DS1, and CR1-CR3 are enabled individually by a high pulse on digital enable outputs II, III, and IV (I is not used). A non-overlapping clock enables each output in succession. Therefore, each is enabled one-fourth of the time. The frequency of this clock is determined by C6, and the refresh rate is made high enough to ensure that no flickering is noticed.

Encoder U1 produces a three-bit output code which indicates which of the eight switches on the inputs are pressed. For example, if input D0 is pulled high by pressing the AUX2 switch, 001 appears on the Q2-Q0 outputs. The three-bit parallel output of U1 is then converted to serial data by parallel-serial converter U3 so that it can be read by the microcontroller using the SPI serial bus. The microphone hanger signal is applied to the D6 input of U3 and read with the switch information.

### High Tier Display Board

Control of most display board functions is provided by microcontroller U2. This device contains a 2K byte ROM and 128 byte RAM and has 20 I/O lines. It communicates with microcontroller U101 on the audio/logic board via the SPI serial bus consisting of SCK, MOSI, and MISO lines (see Section 5.3.1). When there is data to send to the audio/logic board, such as if an option switch is pressed, U2 issues a service request on the Service Request Out line (J1, pin 6).

The functions controlled by U2 are as follows:

- Display controller U1 programming
- Backlight control
- Transmit/Busy indicator CR4 control
- Front panel option switch detection
- Front panel Select switch detection
- Microphone hanger off-hook detection.

## UHF SYNTHESIZER DESCRIPTION

The use of a separate microcontroller on the display board minimizes the number of interconnections required with the audio/logic board because separate lines are not required for each of the preceding functions.

When the front panel Select switch is pressed, the two PBNO lines are shorted together. Then when it is rotated clockwise, low pulses appear on the CW line, and when it is rotated counterclockwise, low pulses appear on the CCW line. The contrast and viewing angle of the display are set by potentiometer R46.

### 5.7 SYNTHESIZER CIRCUIT DESCRIPTION (UHF MODELS)

#### 5.7.1 INTRODUCTION

The synthesizer block diagram is part of the RF/PA board diagram shown in Figure 5-4. The synthesizer output signal is produced by a VCO (Voltage Controlled Oscillator) located in a separate module attached to the RF board. The frequency of the VCO is controlled by a DC voltage from the phase detector in synthesizer integrated circuit U804.

The phase detector senses the phase and frequency difference between a highly stable signal from the reference oscillator ( $f_R$ ) and a frequency produced by dividing down the VCO signal ( $f_V$ ). When the signal from the VCO is the same as the reference frequency, the VCO is on the correct frequency. If the VCO-derived signal is not the same, the VCO control voltage increases or decreases to change the VCO frequency until they are the same. The VCO is then “locked” on frequency.

The reference input ( $f_R$ ) to the phase detector is produced by dividing down the signal from reference oscillator U806. The  $f_R$  input is 50 kHz for all UHF channels. Therefore, the reference divider in U804 divides the 14.850 MHz reference oscillator signal by 297. The TCXO frequency stability is 2.0 PPM, so this is also the stability of the synthesizer (and the second injection signal which is derived from the TCXO frequency).

The VCO-derived input to the phase detector ( $f_V$ ) is the VCO frequency divided down by programmable dividers in synthesizer U804. The prescaler and main

divider are programmed for each channel to produce an input frequency to the phase detector ( $f_V$ ) that is the same as the 50 kHz reference frequency ( $f_R$ ) when the VCO is oscillating on the correct frequency. Refer to Section 5.7.5 for more information on U804 operation.

#### 5.7.2 VOLTAGE-CONTROLLED OSCILLATOR

##### Introduction

The VCO module is a separate assembly that is soldered directly to the RF board and covered by a metal shield. It uses a ceramic substrate that can easily be damaged by excessive heat; therefore, it is recommended that modules which have been removed using a standard soldering iron not be reused. In addition, the VCO center frequency is set by laser tuning ceramic resonator L101. Therefore, it is not possible to adjust this frequency if it changes as the result of changing a part. For these reasons, the VCO is considered not field serviceable.

##### Oscillator (Q102)

The VCO is formed by bipolar transistor Q102, ceramic resonator L101, and several capacitors and varactor diodes. It oscillates at the transmit frequency in the transmit mode and 45 MHz below the receive frequency in the receive mode (the first injection frequency).

Biasing of Q102 is provided by R108 and R112, and stabilization is provided by R114. Inductor L102 functions as an RF choke, and an AC voltage divider formed by C112, C115, and C119 starts and maintains oscillation and matches Q102 to the tank circuit.

The tank circuit consists of laser tuned inductor L101, varactor diodes CR101, CR103-CR106, and several capacitors. Inductor L101 is laser trimmed to set the VCO to the center of the operating band when the control voltage is at its midpoint.

The output signal on the collector of Q102 is coupled by C108 to a cascode buffer amplifier formed by Q100 and Q101. This is a shared-bias amplifier which provides amplification and also isolation between the VCO and stages which follow. C113 provides impedance matching on the input, and the

UHF SYNTHESIZER DESCRIPTION

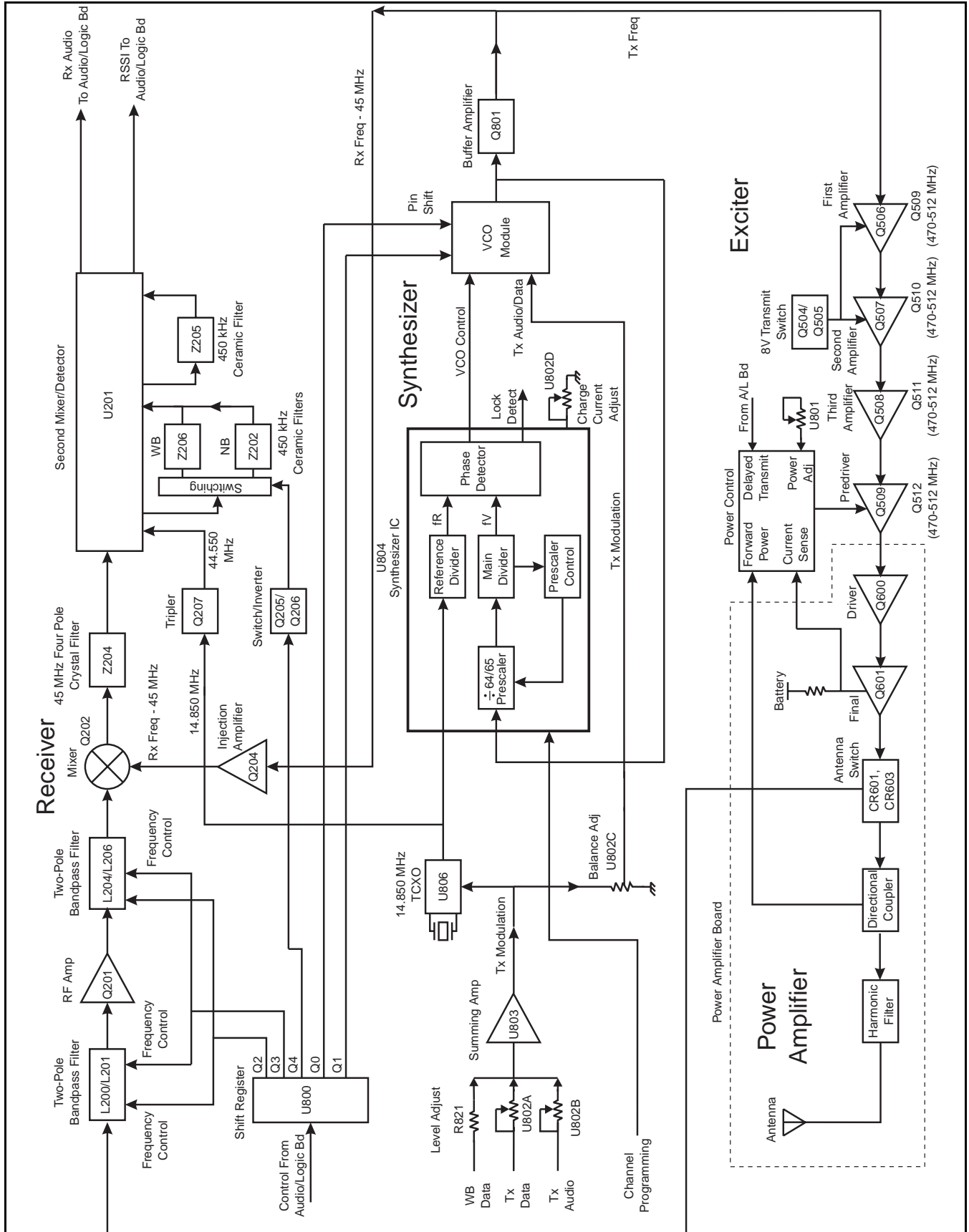

Figure 5-4 RF Block Diagram (UHF Models)

## UHF SYNTHESIZER DESCRIPTION

resistors in the circuit provide biasing and stabilization (R100 also provides current limiting). C100, C101, and C106 are RF decoupling capacitors, and C105 provides an AC ground on the base of Q100.

The output signal on the collector of Q101 is directly coupled to the emitter of Q100. Impedance matching on the output of Q100 is provided by L100, C102, and C103. Resistor R102 lowers the Q of L100 to make it less frequency selective. The VCO signal is then fed to buffer Q801 and synthesizer chip U804 on the RF board.

### VCO Frequency Shifting

In a particular UHF band, the VCO must be capable of producing frequencies from the receiver first injection frequency for the lowest channel up to the transmit frequency for the highest channel. Since the first injection frequency is 45 MHz below the receive frequency and the frequency band could be up to approximately 42 MHz wide, this results in a required VCO frequency spread of up to 87 MHz. If this large frequency shift was achieved only by varying the VCO control voltage, the VCO gain would be undesirably high. Instead, capacitance is switched in and out of the tank circuit to provide a coarse shift in frequency and fine shift is provided by the control voltage.

This switching is provided by PIN diodes CR104 and CR105 and controlled by a logic signal from the Q0 and Q1 outputs (pins 4 and 5) of shift register U800. When a PIN diode is forward biased, it presents a very low impedance to RF signals. Conversely, when it is reverse biased, it presents a very high impedance to RF signals.

Forward biasing one of these PIN diodes adds capacitance to the tank circuit which lowers its resonant frequency. Capacitance is added to the circuit when the control signal is low. Therefore, the lowest frequency is selected when both control lines are low, and the highest frequency is selected when both are high.

For example, when Shift 1 goes low, CR104 is forward biased by current flowing through R103 and L105. Capacitor C111, which is part of the tank circuit, is then effectively AC grounded through

CR104 and C107/C123. The control line is isolated from tank circuit RF by choke L105 and decoupling capacitor C104. The Shift 1 and Shift 2 logic signals for each band segment are listed in Section 6.3.3.

### Frequency Control and Modulation

Fine VCO frequency control is performed by varying the DC voltage across varactor diodes CR103 and CR106 (coarse control is provided as described in the preceding description). As the DC voltage applied to a reverse-biased varactor diode increases, its capacitance decreases. Therefore, the VCO frequency increases as the control voltage increases and vice versa. The amount of frequency change produced by CR103 is set by series capacitor C118 and varactor diode CR106. The control line is isolated from tank circuit RF by L103 and C122.

The VCO is frequency modulated in a similar manner. Another capacitance leg of the tank circuit is formed by C116 and CR101. The audio and data modulation signal is applied across varactor diode CR101, and a fixed bias from a voltage divider formed by R853 and R854 is applied through R851 to pin 5. Isolation and filtering of this DC supply is provided by C838, C839, C840, and R852. Refer to Section 5.7.4 for more information on modulation.

### 5.7.3 ACTIVE FILTER (Q800), BUFFER AMPLIFIER (Q801)

Q800 functions as a capacitance multiplier to provide a filtered 5.5-volt supply to the VCO. Resistor R827 provides bias, and C814 provides the capacitance that is multiplied. CR800 decreases the time required to charge C814 when power is turned on. If a noise pulse or other voltage change appears on the collector, the base voltage does not change significantly because of C814. Therefore, base current does not change and the voltage on the emitter remains constant.

Part of the VCO output signal is fed out of the VCO on pin 2 and applied to a second harmonic filter formed by C842 and L802. A 50-ohm load is provided by R855, with C841 providing impedance matching.

Part of the VCO signal is also fed out of the VCO on pin 1 and applied to a 50-ohm, 3 dB pad formed by



## UHF SYNTHESIZER DESCRIPTION

R842, R839, and R843. The signal is then fed to buffer amplifier Q801. Impedance matching is provided by C822, C826, and L801, and temperature-compensated bias is provided by R830, R833, R844, and CR801. Transistor Q801 provides isolation and also amplifies the signal to produce an output level of approximately 0 dBm. Capacitors C817 and C813 decouple RF signals, and L800, C818, C827, R836, R837, and R847 provide impedance matching and the proper signal levels to the receiver and exciter. R832 lowers the Q of L800 to make it less frequency selective.

### 5.7.4 VCO AND TCXO MODULATION

*NOTE: If the wideband data input is used, the external device must provide FCC-approved modulation limiting and splatter filter circuitry and a stable 2.5 VDC reference level.*

Both the reference oscillator and VCO are modulated in order to provide the required frequency response. If only the VCO was modulated, the phase detector in U804 would sense the frequency change and change the control voltage to counteract the change, especially at the lower audio frequencies. If only the reference oscillator was modulated, the VCO frequency would not change fast enough, especially at the higher audio frequencies. By modulating both, a relatively flat response is provided to all modulation frequencies.

Separate audio, data, and wideband data modulation signals are applied to the synthesizer on J201, pins 18, 17, and 16, respectively. The data signal includes LTR and Call Guard signaling, while the wideband data signal comes directly from an external device such as a modem without passing through the limiting and filtering circuitry.

The levels of the audio and data signals are set by digitally controlled variable resistors in U802. These resistors are adjusted in 256 steps by serial data from the microcontroller (see Section 5.3.1). The transmit audio signal is applied to pins 2 and 4 which are the wiper and one leg of a potentiometer. It is fed out on pin 3 which is the other leg of the potentiometer (see Figure 5-4). Likewise, the data signal is fed in on pins 22 and 24 and out on pin 23.

These variable resistors set the modulation level of the audio and data signals and also allow the microcontroller to provide frequency compensation. This compensation is required because modulation tends to increase as the VCO frequency increases (tank circuit capacitance decreases).

The output signals on pins 23 and 3 of U802 are then combined with the wideband data signal and applied to summing amplifier U803. The output signal from U803 is then applied to the reference oscillator on pin 1 and also to a potentiometer on pin 19 of U802. The output on pin 18 of U802 is applied to the VCO on pin 5. This modulates both the reference oscillator and VCO, and the potentiometer in U802 adjusts the balance of these signals.

### 5.7.5 SYNTHESIZER INTEGRATED CIRCUIT (U804)

#### Introduction

A block diagram of synthesizer IC U804 is shown in Figure 5-5. This integrated circuit contains the following stages. The basic operation of U804 is described in Section 5.7.1.

- Reference divider
- Main divider
- Prescaler ( $\div 64/65$ )
- Phase and lock detectors
- Charge pump and divider programming circuitry.

#### Channel Programming

Channels are selected by programming the main divider in U804 to divide by a certain number. This programming is performed by the microcontroller over the SPI serial data bus which consists of CLOCK, DATA, and STROBE lines (see Section 5.3.1). As previously described, this divider is programmed so that when the VCO is oscillating on the correct frequency, the fR and fV inputs to the phase detector are the same frequency.

#### Operation

As stated in Section 5.7.1, the fR input to the main phase detector is 50 kHz for all channels (either 6.25 or 10 kHz channel spacing). The 14.850 MHz

## UHF SYNTHESIZER DESCRIPTION

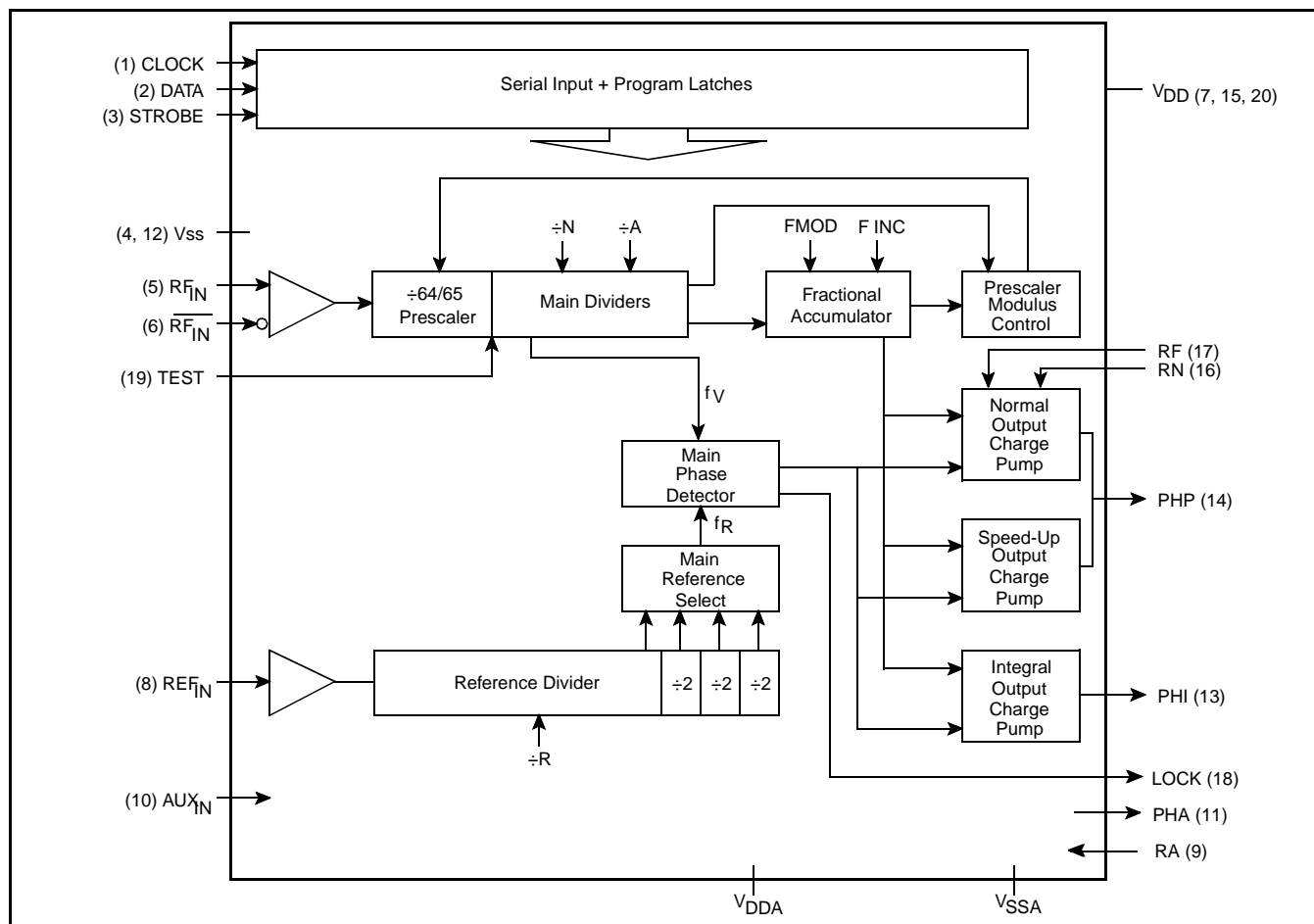

Figure 5-5 Synthesizer Chip U804 Block Diagram

reference oscillator frequency is divided by 297 to produce this signal. Fractional-N division with modulo 5 or 8 selection allows the loop frequency to be 5 or 8 times the channel spacing. Modulo 8 is used to allow 6.25 kHz (12.5 kHz) channel spacing.

The  $f_V$  input is produced by dividing down the VCO frequency applied to the RF IN input. The first divider is a prescaler which is a special counter capable of operating at relatively high frequencies. This counter divides by 64 and 65 in this application. This divides a signal in the 400 MHz range down to approximately 6 MHz. For each main divider output pulse, the prescaler divides by 65 for a certain number of pulses and then 64 for an additional number of pulses. The number counted in each mode is determined by the programming of the “N” and “A” divide numbers. The basic operation is as follows:

The main divider begins counting down from the “A” number. Then when zero is reached, it begins counting down from the “N” number until zero is reached. The cycle then repeats. While it is counting down the “A” number, the prescaler divides by 65, and while it is counting down the “N” number, it divides by 64.

To illustrate the operation of these dividers, an example will be used. Assume a transmit frequency of 450.750 MHz is selected. Since the VCO oscillates on the transmit frequency in the transmit mode, this is the frequency that must be produced by the VCO. To produce this frequency, the “N” and “A” divide numbers are programmed as follows:

$$N = 83 \qquad A = 55$$

## UHF SYNTHESIZER DESCRIPTION

To determine the overall divide number of the prescaler and main divider, the number of input pulses required to produce one main divider output pulse can be determined. Although the programmed “N” number is 83 in this example, the divide number is always two higher (85) because of reset cycles and other effects. Therefore, the prescaler divides by 65 for  $55 \times 65$  or 3575 input pulses. It then divides by 64 for  $85 \times 64$  or 5440 input pulses. The overall divide number K is therefore  $3575 + 5440$  or 9015. The VCO frequency of 450.750 MHz divided by 9015 equals 50 kHz which is the fR input to the phase detector.

If the VCO frequency is not evenly divisible by 50 kHz, there is also a fractional-N number programmed that provides the required fractional divide number. Refer to the 800/900 MHz description in Section 5.10.6 for more information.

*NOTE: The formulas for calculating the N and A divide numbers are described in Section 6.3.5.*

### 5.7.6 LOCK DETECT

When the synthesizer is locked on frequency, the LOCK output of U804 (pin 18) is a logic high voltage. Then when the synthesizer is unlocked, this voltage is low. A locked condition exists when the phase difference at the TCXO input is less than one cycle.

### 5.7.7 CHARGE PUMP

The charge pump circuit in U804 charges and discharges C833-C836 in the loop filter to produce the VCO control voltage. Resistors connected to the RN and RF pins set the charge current. The RF pin resistance is set by a digitally controlled potentiometer in U802. This resistance changes with the frequency band in order to minimize fractional-N spurious signals. The loop filter provides low-pass filtering which controls synthesizer stability and lockup time and suppresses the loop reference frequency (50 kHz).

### 5.7.8 SHIFT REGISTER (U800, U801) AND DIGITAL POTENTIOMETER (U802) PROGRAMMING

Shift register U800 functions as an I/O port expander, and shift register U801 functions as a D/A converter to provide a 256-step output voltage for

adjusting transmitter power. In addition, the Q7 output of U801 provides the transmit/receive signal. U802 contains four digitally controlled potentiometers that are also adjustable in 256 steps.

These devices are cascaded together on the serial bus so that data is shifted out of one device into another. Programming is performed using the SPI serial port of the microcontroller described in Section 5.3.1. The input to the internal shift register of these devices is the DATA pin (U800/U801) or SDI pin (U802), and the output of the last shift register stage in U800 and U801 is the  $\overline{QS}$  pin. Therefore, serial data on the Data line from the audio/logic board (J201, pin 14) is first shifted into U801, then U800, and then U802.

Data is clocked through the devices by the CLOCK signal (J201, pin 13) when the STROBE input (J201, pin 12) is high and latched when it goes low. Synthesizer IC U804 is also programmed by the SPI port. However, data does not pass through the other devices, and it is controlled by different STROBE signal (J201, pin 1).

## 5.8 RECEIVER CIRCUIT DESCRIPTION (UHF MODELS)

*NOTE: The receiver block diagram is shown in Figure 5-4.*

### 5.8.1 FRONT END FILTER

The receive signal is fed from the antenna switch circuit on the PA board to the receiver front end on the RF board. The signal is fed through a section of microstrip that is part of a quarter-wave line for the antenna switch. Also part of the antenna switch circuit is C201, CR200, and R200. Refer to Section 5.9.4 for more antenna switch information.

The receive signal is applied to a two-pole band-pass filter formed by ceramic resonators L200 and L201, several capacitors, and PIN diodes CR201 and CR202. The function of this filter is to attenuate frequencies outside the receive band such as the first injection, image, and half IF frequencies. The pass-band frequency of the filter is shifted in four steps using PIN diodes. These diodes are controlled by microcontroller through the Q2 and Q3 outputs of shift

## UHF RECEIVER DESCRIPTION

register U800. The control signals for each of four band segments are listed in Section 6.4.

The PIN diodes present a very low impedance at RF frequencies when forward biased and a very high impedance when reverse biased. This allows them to be used to switch capacitance in and out of the filter. For example, when the lowest segment of the frequency band is selected, both control signals are high and the diodes are forward biased by current flowing through R201-R204. Therefore, C207, C208, C218, and C219 are effectively connected to ground through CR201 and CR202 which lowers the passband frequency of the filter.

Ceramic resonators L200 and L201 have a very high Q and therefore cause very little receive signal loss. Capacitors on the input and output of the filter provide impedance matching with the adjoining stages.

### 5.8.2 RF AMPLIFIER (Q201)

RF amplifier Q201 improves and stabilizes receiver sensitivity and also recovers filter losses. Several capacitors on the input and also L202 provide impedance matching. CR203 protects the base-emitter junction of Q201 from damage caused by high level input signals.

The bias current of Q201 is fixed at a constant level by Q200. The collector current of Q201 flows through R207. The voltage drop across that resistor (and therefore the current) is set by R205 and R206. For example, if current through R207 attempts to increase, the emitter voltage of Q200 decreases. Q200 then conducts less and turns Q201 off slightly to maintain a constant bias current. This provides a stable bias over changes in temperature.

The output signal of Q201 is fed to another two-pole bandpass filter similar to the one on the input of Q201 as described in the preceding section. Impedance matching with the filter is provided by L203, C227, C228, C234, and C235. Resistor R209 lowers the Q of L203 to make it less frequency selective. C222-C226 decouple various unwanted AC signals from the circuit.

### 5.8.3 FIRST MIXER (Q202), INJECTION AMPLIFIER (Q204)

Q202 is a dual-gate MOSFET mixer. Impedance matching at one gate is provided by C245, R214, and L207. The first injection frequency from the synthesizer is applied to the other gate. Since the first IF is 45 MHz and low-side injection is used, the injection frequency is 45 MHz below the receive frequency.

The signal from the synthesizer is amplified by Q204. A 3 dB pad on the output, consisting of R225-R227, sets the input level to the mixer. A low-pass filter network formed by C262-C264 and L211 attenuates spurious frequencies occurring above the injection frequency band. Q203 provides a stable bias current similar to Q200 described in Section 5.8.2. Temperature compensation is provided by CR206 which mirrors the voltage drop across the base-emitter junction of Q204.

Impedance matching on the output of mixer Q202 is provided at 45 MHz by L208, C251, and C252. The signal is then fed to Z204 which is a four-pole crystal filter with a nominal  $-3$  dB bandwidth of 15 kHz. This filter attenuates wideband noise, adjacent channels, frequencies resulting from intermodulation, and other undesired frequencies. Impedance matching on the input is provided by C251, C252, C266, C268, and L213; impedance matching on the output is provided by C270, C271, C272, L215, and R228.

### 5.8.4 SECOND MIXER/DETECTOR (U201)

#### Second Mixer

U201 contains second mixer, IF amplifier, detector, RSSI, and audio amplifier stages as shown in Figure 5-6. The 45 MHz IF signal is applied to pin 2 which is the input of an internal IF amplifier stage. From the IF amplifier the signal is internally fed to the mixer which combines it with the 44.550 MHz second injection frequency to produce a second IF of 450 kHz.

The 44.550 MHz injection frequency on pin 4 is produced by tripling the 14.850 MHz frequency of reference oscillator U806. To do this, a portion of the reference oscillator signal is applied to Q207 which is an amplifier with the output tuned for the third

## UHF RECEIVER DESCRIPTION

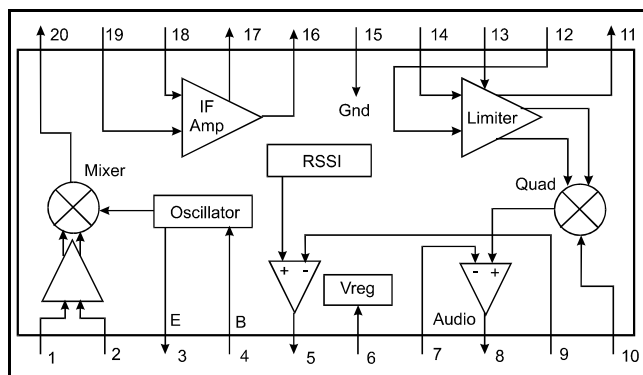

**Figure 5-6 Limiter/Detector U201 Block Diagram**

harmonic of the reference oscillator frequency. This output tuning is provided by a two-pole bandpass filter formed by L219, C287, C288, L217, and C290. The output level of this filter is approximately 0.25 V rms.

#### Ceramic Filters (Z202/Z206, Z205)

The 450 kHz output of the internal mixer is fed out of U201 on pin 20. It is then routed through ceramic filter Z202 for narrow-band (12.5 kHz) channels and through Z206 for wideband (25 kHz) channels. Z202 has a nominal bandwidth at the  $-3$  dB points of 8 kHz, and Z206 has a nominal bandwidth of 15 kHz. The function of this filter is to attenuate wideband noise present in the IF signal.

Routing of the IF signal to the appropriate filter is provided by Q205 and Q206, PIN diodes CR207-CR210, and several resistors and capacitors. It is controlled by the microcontroller through the Q4 output of shift register U800. This output is low for narrow-band channels and high for wideband channels.

If a narrow-band channel is selected, a low signal is applied to the base of Q205. That transistor then turns off and inverter Q206 turns on. CR209/CR210 are then forward biased and CR207/CR208 reverse biased. This routes the 450 kHz IF signal through Z202 and blocks it from Z206. If a wideband channel is selected, the opposite occurs. For more information on the operation of PIN diodes, refer to Section 5.8.1.

The filtered 450 MHz IF signal is then applied to pin 18, amplified by an internal amplifier, and then fed back out on pin 16 and applied to ceramic filter Z205. This filter is identical to Z206 and provides additional

attenuation of wideband noise. The loss introduced by each ceramic filter is approximately 12 dB.

#### Limiter/Detector

The signal from Z205 is applied to an internal limiter connected to pin 14. The limiter amplifies the 450 kHz signal and then limits it to a specific value to remove amplitude variations. From the limiter, the signal is fed internally to the quadrature detector. An external phase shift network connected to pin 10 shifts the phase of one of the detector input signals  $90^\circ$  at 450 kHz (the other input is unshifted in phase). When modulation occurs, the frequency of the IF signal changes at an audio rate as does the phase of the shifted signal. The detector, which has no output with a  $90^\circ$  phase shift, converts this phase shift into an audio signal. Inductor L219 is tuned to provide maximum undistorted output from the detector.

The audio signal is then fed internally to an audio amplifier. The gain of this stage is set at about three by R255 and R256. The audio output signal on pin 8 is then fed to the audio/logic board.

Also in U201 is an RSSI detector which provides a temperature compensated RSSI (Receive Signal Strength Indicator) signal on pin 5. This is a low impedance (2k ohm) output with a dynamic range of 70 dB. It provides an indication of IF signal strength which changes in proportion to changes in signal strength. It is routed to an A/D input of the microcontroller (pin 59) and used along with the squelch signal to determine receive signal strength. R259/C304 and R258/C303 provide low pass filtering, and C305 and C306 decouple RF on the audio and RSSI output lines.

## 5.9 TRANSMITTER CIRCUIT DESCRIPTION (UHF MODELS)

*NOTE: A transmitter block diagram is in Figure 5-4.*

### 5.9.1 FIRST AND SECOND AMPLIFIERS

#### 430-470 MHz Models

The input signal to the exciter is the transmit frequency from buffer amplifier Q801 in the synthesizer. It is at a level of approximately 0 dBm and is applied to first amplifier Q506. Impedance matching

## UHF TRANSMITTER DESCRIPTION

on the input of Q506 is provided by C529, C537, L505, and C530. The input level is set by R528 and R530. Biasing is provided by R520 and R525, and C525/C526 and C520/C521 decouple RF signals. Impedance matching on the output is provided by L502, C570, C531, L506, and C532. Second amplifier Q507 is similar in design to Q506. These stages together produce about 20 dB of gain.

The 8-volt supply to Q506 and Q507 is switched on in the transmit mode by Q505 and Q504. This switch is controlled by the microcontroller through the Q7 output (pin 11) of shift register U801. This output is high in the transmit mode and low in the receive mode. This signal also controls the antenna switch circuit on the PA board described in Section 5.9.4.

This transmit 8V supply is not delayed which allows Q506 and Q507 and the transmitter frequency to stabilize before power is produced. The delayed PTT signal is applied to the RF board on J201, pin 2. This signal controls the power control circuit described in Section 5.9.6. The emitters of Q503 and Q505 are grounded through Q517. That transistor is turned off when the logic is in an undetermined state such as during Flash programming. This ensures that the transmitter is turned off during these times.

### 470-512 MHz Models

The input signal to the exciter is the transmit frequency from buffer amplifier Q801 in the synthesizer. It is at a level of approximately 0 dBm and is applied to first amplifier Q509. Impedance matching on the input of Q509 is provided by C540, C552, L503, C550, C551, and L504. Biasing is provided by R531 and R535, and C526/C527 and C521/C523 decouple RF signals. Impedance matching on the output is provided by L501, C541, C555, and C556. Second amplifier Q510 is similar in design to Q509. These stages together produce about 20 dB of gain. Power to Q509 is switched by Q506 similar to the 430-470 MHz version just described.

## 5.9.2 THIRD AMP AND PREDRIVER

### 430-470 MHz Models

From Q507 the signal is fed to third amplifier Q508 which provides approximately 10 dB of gain.

Impedance matching with Q507 is provided by L503, C571, C533, C538, L504, L507, C579, and C539. Biasing is provided by R5542, R555, and R532.

Impedance matching between Q508 and Q509 is provided by L501, several capacitors, and two sections of microstrip. Microstrip is a form of transmission line with distributed series inductance and shunt capacitance. The characteristic impedance is determined by the width of the microstrip and the PC board material and thickness (distance from ground plane). Resistor R523 lowers the Q of L501 to make it less frequency selective. Q508 is powered by the switched battery supply. AC signals are decoupled from this supply by C517-C519 and ferrite bead EP500.

Predriver Q509 is an RF power MOSFET. The gate is biased at approximately one-half the drain voltage by R519 and R522. Capacitors C512-C516, C522, and C523 provide decoupling of AC signals. R524 and R527 lower the Q of the input matching circuit which improves stability.

Supply voltage to Q509 is from the power control circuit described in Section 5.9.6. This circuit varies the supply voltage to change the power output of Q509 in order to maintain constant transmitter power output. RF choke L500, ferrite bead EP501, and several capacitors isolate the power control circuit from RF signals. Several capacitors and sections of microstrip on the drain of Q509 provide an output impedance of 50 ohms to the power amplifier board. This stage provides a gain of approximately 10 dB, resulting in a power input to the PA board of up to approximately 8 watts.

### 470-512 MHz Models

From Q510 the signal is fed to third amplifier Q511 which is a power MOSFET that provides approximately 10 dB of gain. Impedance matching with Q510 is provided by L502, C542, C557, L505, and C543. Resistors R532 and R534 lower the Q of the input matching circuit which improves stability. The gate of Q511 is biased by R527 and R528. Decoupling of RF signals is provided by C528/C529 and C516/C517.

Supply voltage to Q511 is from the power control circuit described in Section 5.9.6. This circuit varies

## UHF TRANSMITTER DESCRIPTION

the supply voltage to change the power output of Q511 in order to maintain constant transmitter power output.

Impedance matching with between Q511 and predriver Q512 is provided by several capacitors and sections of microstrip (microstrip is described in the preceding section). Class C biasing of Q512 is provided by L506 and ferrite bead EP2. Several more capacitors and sections of microstrip on the output of Q512 provide matching with the 50-ohm input impedance of the power amplifier. This stage provides a gain of approximately 10 dB, resulting in a power input to the PA board of up to approximately 8 watts.

### 5.9.3 DRIVER (Q600), FINAL (Q601)

Driver Q600 on the power amplifier board is used with high power (40 watt) versions only. It is matched to the 50 ohms by several capacitors and sections of microstrip on the input. Class C self bias is provided by L608 and ferrite bead EP603. From Q600 the signal is fed to final amplifier Q601 which is similar in design to Q600. Each stage has a gain of approximately 5 dB, resulting in an output power from Q601 of approximately 55 watts.

The supply voltage to these stages is the unswitched battery supply. Therefore, power is applied even when transceiver power is turned off. Two RF chokes, a ferrite bead, and several capacitors isolate this supply from RF signals. Current to final amplifier Q601 flows through R600, and the power control circuit monitors transmitter current by sensing the voltage drop across it.

### 5.9.4 ANTENNA SWITCH

The antenna switch circuit consists of Q602, CR601, CR603, several other components, and also a section of microstrip and CR200 on the RF board. This circuit switches the antenna to the receiver in the receive mode and the transmitter in the transmit mode.

Switching transistor Q602 is controlled by the transmit signal from the Q7 output (pin 11) of shift register U807. This is the same signal that controls transmit 8-volt supply switch Q506/Q507. This signal is high in the transmit mode and low in the receive mode. Therefore, Q602 turns on in the transmit mode

and current flows from the collector of final amplifier Q601 through L601, CR601/R602, L606, R608/CR603, R609, and R610.

Diodes CR601 and CR603 are PIN diodes like those in the receiver front end (see Section 5.8.1). When a PIN diode is forward biased, it presents a very low impedance. Therefore, the transmit signal has a low-impedance path through CR601 to the directional coupler and C614. With CR603 also forward biased, it effectively connects L606 to AC ground through C652. A parallel resonant circuit is then formed by L606 and C643 which presents a high impedance into the receiver for the transmit signal.

Further receiver isolation in the transmit mode is provided by a grounded quarter-wave line. This quarter-wave line is formed by the section of microstrip connected to C650/C651 and another section on the RF board. The receiver end of this quarter-wave line is AC grounded by PIN diode CR200 on the RF board. This diode is forward biased in the transmit mode by the 8-volt transmit supply applied through R200. When one end of a quarter-wave line is grounded, the other end presents a high impedance to the quarter-wave frequency (the transmit frequency band in this case). C650 and C651 on the PA board provide impedance matching.

In the receive mode, all three PIN diodes are reverse biased. Therefore, CR601 presents a high impedance into the transmitter for the receive signal, L606 presents a low impedance because it is no longer resonant, and the quarter-wave line presents a low impedance because it is no longer grounded by CR200.

### 5.9.5 DIRECTIONAL COUPLER, LOW-PASS FILTER

The transmit signal is fed to a directional coupler formed by adjacent sections of microstrip. The forward component of output power is rectified by CR602 and developed across R607 and fed to the power control circuit. Reverse power is not detected in this transceiver.

From the directional coupler the transmit signal is fed to a low-pass harmonic filter formed by L602-L604 and several capacitors. This filter attenuates

## UHF TRANSMITTER DESCRIPTION

harmonic frequencies occurring above the transmit band. R603 dissipates static buildup on the antenna.

The ambient power amplifier temperature is sensed by thermistor R601. The resistance of a thermistor decreases as temperature increases. R601 and R143 on the audio/logic board form a voltage divider, and the voltage across this divider is monitored by an A/D converter input of the microcontroller (pin 63). If the PA temperature increases above limits set in software, the power is first cut back. Then if it continues to rise, the transmitter is turned off. Refer to Section 3.5.18 for more information.

### 5.9.6 POWER CONTROL (U500A/B, Q500-Q503)

#### Introduction

The power control circuit maintains a constant power output as changes occur in temperature and voltage. It does this by varying the supply voltage to predriver Q509 (430-470 MHz) or third amplifier Q511 (470-512 MHz). This changes the power output of that stage which in turn controls the power output of the transmitter. The power control circuit senses forward power to control power output. The current to final amplifier Q601 is also sensed, but it affects power output only if it becomes excessive. Gradual power shutdown then occurs.

The power output level is set in 127 steps by D/A converter U801 that is controlled by the microcontroller. This allows power to be adjusted from the front panel using the test mode and also different power levels to be programmed for each system. In addition, it allows the microcontroller to cut back power when power amplifier temperature is excessive as just described (see Section 5.9.5).

#### U500A, Q500/Q502 Operation

The forward power signal from the directional coupler is applied to pin 2 of amplifier U500A. This is a DC signal that increases in proportion to forward power. The other input to U500A is a DC voltage from a D/A converter formed by shift register U801 and several resistors. This stage is similar in design to D/A converter U305 described in Section 5.4.4. Programming of U801 is described in Section 5.7.8. The voltage from this D/A converter sets the reference

voltage on pin 3 which sets the power output of the transmitter.

U500A is a difference amplifier which amplifies the difference between the reference voltage on pin 3 and the forward power signal on pin 2. The turn-on time of U500A is controlled by the time constant of C502 and R508. Negative AC feedback to prevent oscillation is also provided by C502. This circuit operates as follows: Assume the output power attempts to increase. The DC voltage applied to U500A, pin 2 then increases which causes the output voltage on pin 1 to decrease. Transistors Q502 and Q500 then turn off slightly which decreases the supply voltage to predriver Q509 (or third amplifier Q511). The output power then decreases to maintain a constant power output. R510 and R513 limit the voltage gain of Q500 and Q503 to approximately two.

#### Delayed PTT

Transistor Q503 is used to delay power output for a short time after the transmitter is keyed. This allows the synthesizer and the exciter to stabilize so that the transmitter does not transmit off-frequency. The signal which controls Q503 is from the Q2 output (pin 17) of latch U111 on the audio/logic board. In the receive mode this output is low, so Q503 is off. Pin 2 of U500A is then pulled high by the 8-volt supply applied through R505 and CR503. This causes the output on pin 1 of U500A to go low which shuts off power to Q509 (or Q511). Then when the transmitter is keyed, the Q503 control signal goes high after a short delay. Q503 then turns on and diode CR503 is reverse biased. Only the forward power signal is then applied to pin 2 of U500A.

#### Over Current Shutdown

Current to final amplifier Q601 on the PA board is monitored by sensing the voltage drop across R680. Pins 5 and 6 of U500B are effectively connected across this resistor. As current increases, the voltage on U500B, pin 6 decreases which causes the output voltage on pin 7 to increase. The gain of each U500B input is set at ten by R509/R504 and R507/R502.

Emitter biasing for Q501 is provided by R506 and R511. Normally, the output voltage of U500B is



800/900 MHz SYNTHESIZER DESCRIPTION

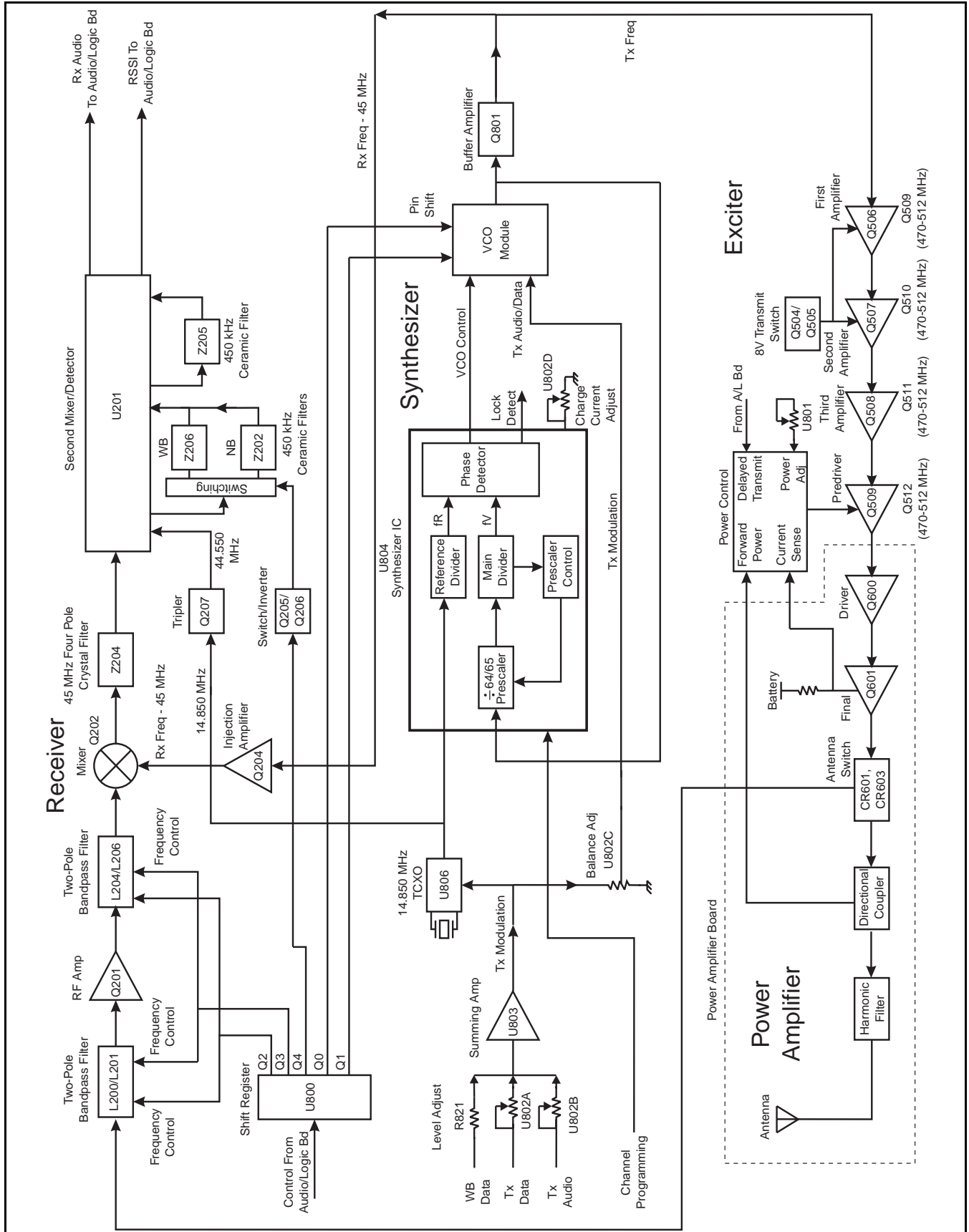

Figure 5-7 RF Block Diagram (800/900 MHz Models)

## 800/900 MHz SYNTHESIZER DESCRIPTION

not high enough to turn on Q501. However, if current becomes excessive, for example because of an antenna mismatch, Q501 begins turning on. This decreases the base voltage of Q502 which turns off Q500 slightly and cuts back power output.

### 5.10 SYNTHESIZER CIRCUIT DESCRIPTION (800/900 MHz MODELS)

#### 5.10.1 INTRODUCTION

The synthesizer block diagram is part of the RF/PA board diagram shown in Figure 5-7. The synthesizer output signal is produced by a VCO (Voltage Controlled Oscillator) located on a separate module attached to the RF board. The frequency of the VCO is controlled by a DC voltage from the phase detector in synthesizer integrated circuit U804.

The phase detector senses the phase and frequency difference between a highly stable signal from the reference oscillator ( $f_R$ ) and a frequency produced by dividing down the VCO signal ( $f_V$ ). When the signal from the VCO is the same as the reference frequency, the VCO is on the correct frequency. If the VCO-derived signal is not the same, the VCO control voltage increases or decreases to change the VCO frequency until they are the same. The VCO is then “locked” on frequency.

The reference input ( $f_R$ ) to the phase detector is produced by dividing down the signal from reference oscillator U806. The  $f_R$  input is 50 kHz for all 800 and 900 MHz channels. Therefore, with 900 MHz models, the reference divider in U804 divides the 14.850 MHz reference oscillator signal by 297, and with 800 MHz models, it divides the 17.500 MHz reference oscillator signal by 350. The TCXO frequency stability is 1.5 PPM, so this is also the stability of the synthesizer (and the second injection signal which is derived from the TCXO frequency).

The VCO-derived input to the phase detector ( $f_V$ ) is the VCO frequency divided down by programmable dividers in synthesizer U804. The prescaler and main divider are programmed for each channel to produce an input frequency to the phase detector ( $f_V$ ) that is the same as the 50 kHz reference frequency ( $f_R$ ) when the VCO is oscillating on the correct frequency. Refer to Section 5.10.6 for more information on U804 operation.

#### 5.10.2 VOLTAGE-CONTROLLED OSCILLATOR

##### Introduction

The VCO module is a separate assembly that is soldered directly to the RF board and covered by a metal shield. It uses a ceramic substrate that can easily be damaged by excessive heat; therefore, it is recommended that modules which have been removed using a standard soldering iron not be reused. In addition, the VCO center frequency is set by laser tuning ceramic resonator L907. Therefore, it is not possible to adjust this frequency if it changes as the result of changing a part. For these reasons, the VCO is considered not field serviceable.

##### Oscillator (Q902)

The VCO is formed by bipolar transistor Q902, ceramic resonator L907, and several capacitors and varactor diodes. It oscillates at the transmit frequency in the transmit mode and 52.950 (800 MHz) or 45 MHz (900 MHz) below the receive frequency in the receive mode (the first injection frequency).

Biasing of Q902 is provided by R906 and R908, and stabilization is provided by R912. Inductor L906 functions as an RF choke, and C924 is an AC bypass capacitor. An AC voltage divider formed by C913, C917, and C921 starts and maintains oscillation and matches Q902 to the tank circuit.

The tank circuit consists of laser tuned inductor L907, varactor diodes CR902-CR904, and several capacitors. Inductor L907 is laser trimmed to set the VCO to the center of the operating band when the control voltage is at its midpoint.

The output signal on the collector of Q902 is coupled by C911 to a buffer amplifier formed by Q901 and Q903. This is a shared-bias amplifier which provides amplification and also isolation between the VCO and stages which follow. C918 provides impedance matching on the input, and the resistors in the circuit provide biasing and stabilization (R913 also provides current limiting). C901, C902, and C908 are RF decoupling capacitors, and C909 and C919 provide an AC ground on the emitters of Q901 and Q903.

The output signal on the collector of Q903 is fed through C914 to synthesizer U804. A 50-ohm load is

## 800/900 MHz SYNTHESIZER DESCRIPTION

provided by R855, and C841, C842, and C849 provide impedance matching. Likewise, the output signal on the collector of Q901 is fed through C904 to buffer amplifier Q801 (see Section 5.10.5). Resistor R902 lowers the Q of L903 to make is less frequency selective.

### VCO Frequency Shifting

In the applicable 800 or 900 MHz band, the VCO must be capable of producing frequencies from the lowest receiver first injection frequency up to the highest talk-around mode transmit frequency. At 800 MHz, the lowest VCO frequency is 798.0625 MHz (52.950 MHz below the lowest receive frequency of 851.0125 MHz) and the highest talk-around frequency is 869.9875 MHz. Therefore, the VCO frequency band spread is approximately 72 MHz. If this large frequency shift was achieved only by varying the VCO control voltage, the VCO gain would be undesirably high. Instead, capacitance is switched in and out of the tank circuit to provide a coarse frequency shift.

This switching is provided by PIN diode CR901 which is controlled by the logic signals from the Q0 and Q1 outputs (pins 4 and 5) of shift register U800. Q803 and Q804 function as inverters and drivers. When a PIN diode is forward biased, it presents a very low impedance to RF signals. Conversely, when it is reverse biased, it presents a very high impedance.

Forward biasing of PIN diode CR901 adds capacitance to the tank circuit which lowers its resonant frequency. The diode is forward biased in the normal mode and reverse biased in the talk-around mode (both 800 and 900 MHz). The logic levels on pins 3 and 4 of the VCO are as follows:

	<b>Pin 3</b>	<b>Pin 4</b>
<b>Normal Mode</b>	H (5.5V)	L (0V)
<b>Talk-Around Mode</b>	L (0V)	H (5.5V)

In the normal mode, CR901 is forward biased by current flowing through R903, L905, CR901, and L902. Capacitors C907 and C912 are then effectively AC grounded through CR901 and C905. The control lines are isolated from tank circuit RF by L902/C903, L905/C906, C811, C812, C823, and C824.

### Frequency Control and Modulation

Fine VCO frequency control is performed by varying the DC voltage across varactor diodes CR903 and CR904 (coarse control is provided as described in the preceding description). As the DC voltage applied across a reverse-biased varactor diode increases, its capacitance decreases. Therefore, the VCO frequency increases as the control voltage increases and vice versa. The amount of frequency change produced by CR903 and CR904 is set by series capacitor C922. A DC ground is provided by L908, and the control line is isolated from tank circuit RF by L909 and C925.

The VCO is frequency modulated in a similar manner. Another capacitance leg of the tank circuit is formed by C915, C920, and varactor diode CR902. The audio and data modulation signal is applied across CR902, and a fixed bias from a voltage divider formed by R853 and R854 is applied through R851 to pin 5. Isolation and filtering of this DC bias is provided by C838, C839, C840, and R852. Refer to the next section for more information on modulation.

### 5.10.3 VCO AND TCXO MODULATION

*NOTE: If the wideband data input is used, the external device must provide FCC-approved modulation limiting and splatter filter circuitry and a stable 2.5 VDC reference level.*

Both the reference oscillator and VCO are modulated in order to provide the required frequency response. If only the VCO was modulated, the phase detector in U804 would sense the frequency difference and change the control voltage to counteract it, especially at the lower audio frequencies. Conversely, if only the reference oscillator was modulated, the VCO frequency would not change fast enough, especially at the higher audio frequencies. By modulating both, a relatively flat response is provided for all modulation frequencies.

Separate audio, data, and wideband data modulation signals are applied to the synthesizer on J201, pins 18, 17, and 16, respectively. The data signal includes LTR and Call Guard signaling, and the wideband data signal (if used) comes directly from an external device such as a modem and does not pass through the limiting and filtering circuitry.

## 800/900 MHz SYNTHESIZER DESCRIPTION

The levels of the audio and data signals are set by digitally controlled variable resistors in U802. These resistors are adjusted in 256 steps by serial data from the microcontroller (see Section 5.3.1). The transmit audio signal is applied to pins 2 and 4 which are the wiper and one end of a potentiometer. It is fed out on pin 3 which is the other end of the potentiometer (see Figure 5-7). Likewise, the data signal is fed in on pins 22 and 24 and out on pin 23. These variable resistors set the modulation level of the audio and data signals and also allow the microcontroller to provide frequency compensation. This compensation is required because modulation tends to increase as the VCO frequency increases (tank circuit capacitance decreases).

The output signals on pin 23 and 3 are then combined with the wideband data signal and applied to summing amplifier U803. The output signal from U803 is then applied to the reference oscillator on pin 1 and also across the potentiometer connected to pin 19 of U802. The output on pin 18 is applied to the VCO on pin 5. This modulates both the reference oscillator and VCO. The resistor across pins 19 and 18 of U802 adjusts the balance of these signals.

### 5.10.4 ACTIVE FILTER (Q800)

Q800 functions as a capacitance multiplier to provide a filtered 7.0-volt supply to the VCO. Resistor R827 provides bias, and C814 provides the capacitance that is multiplied. CR800 decreases the time required to charge C814 when power is turned on. If a noise pulse or other voltage change appears on the collector, the base voltage does not change significantly because of C814. Therefore, base current does not change and the voltage on the emitter remains constant.

### 5.10.5 BUFFER AMPLIFIER (Q801), TX/TX SWITCH (CR801/CR802)

The output signal on pin 2 of the VCO is applied to buffer amplifier Q801. Impedance matching on the input is provided by C822, a section of microstrip, and C826. Microstrip is a form of transmission line with distributed series inductance and shunt capacitance. The characteristic impedance is determined by the width of the microstrip and the PC board material and

thickness (distance from ground plane). This stage provides isolation and also amplifies the signal to produce an output level of approximately 0 dBm.

The bias current of Q801 is fixed at a constant level by Q802. The collector current of Q801 flows through R830. The voltage drop across that resistor (and therefore the current) is set by R836 and R837. For example, if current through R830 attempts to increase, the emitter voltage of Q802 decreases. Q802 then conducts less and turns Q801 off slightly to maintain a constant bias current. This provides a stable bias over changes in temperature.

Capacitors C813, C817, C827, and C844 decouple RF signals, and a section of microstrip and C818 provide impedance matching with the transmit/receive switch. R832 lowers the Q of the microstrip to make it less frequency selective.

The transmit/receive switch formed by CR801, CR802, and several other components switches the VCO signal to the receiver in the receive mode and the transmitter in the transmit mode. CR801 and CR802 are PIN diodes similar to CR901 described in Section 5.10.2. Therefore, they present a very low impedance when forward biased and a very high impedance when reverse biased.

These diodes are controlled by the Q2 signal from shift register U800. This signal is high in the transmit mode and low in the receive mode. Therefore, when the transmitter is keyed, both Q805 and Q806 turn on and CR801 and CR802 are forward biased by the current flowing through Q806, R856, L800, CR801, CR802, R857, and Q805.

This effectively AC grounds the receiver end of the quarter-wave line through CR802 and C847. When one end of a quarter-wave line is grounded, the other end presents a high impedance to the quarter-wave frequency. Therefore, the VCO signal is blocked from the receiver by the quarter-wave line and has a low impedance path through CR801 to the transmitter.

In the receive mode, both diodes are reverse biased. The quarter-wave line is then no longer grounded and provides a low impedance path to the receiver while CR802 provides a high impedance into

## 800/900 MHz SYNTHESIZER DESCRIPTION

the transmitter. L801/C846 and L800/C845 improve isolation by neutralizing the slight capacitance of CR801 and CR802 when they are reverse biased.

### 5.10.6 SYNTHESIZER INTEGRATED CIRCUIT (U804)

#### Introduction

A block diagram of synthesizer IC U804 is shown in Figure 5-5 on page 5-16. This integrated circuit contains the following stages. The basic operation of U804 was described in Section 5.10.1.

- Reference (R) divider
- Main divider
- Prescaler ( $\div 64/65$ )
- Phase and lock detectors
- Charge pump and divider programming circuitry

#### Channel Programming

Channels are selected by programming the main divider in U804 to divide by a certain number. This programming is performed by the microcontroller over the SPI serial data bus which consists of CLOCK, DATA, and STROBE lines (see Section 5.3.1). As previously described, this divider is programmed so that when the VCO is oscillating on the correct frequency, the  $f_R$  and  $f_V$  inputs to the phase detector are the same frequency.

#### Operation

As stated in Section 5.10.1, the  $f_R$  input to the main phase detector is 50 kHz for all channels. The reference oscillator frequency is divided by 350 (800 MHz) or 297 (900 MHz) to produce this signal. Fractional-N division with modulo 5 or 8 selection allows the loop frequency to be 5 or 8 times the channel spacing. With 800 and 900 MHz channels, modulo 8 is used to allow 6.25 kHz (12.5 kHz) channel spacing.

The  $f_V$  input is produced by dividing down the VCO frequency applied to the RF IN input. The first divider which divides this signal is a prescaler which is a special counter capable of operating at relatively high frequencies. The prescaler divides by 64 and 65 which reduces a signal in the 800 MHz range down to approximately 12 MHz. For each main divider output

pulse ( $f_V$ ), the prescaler divides by 65 for a certain number of pulses and then 64 for an additional number of pulses. The number counted in each mode is determined by the programming of the “N” and “A” numbers. The basic operation is as follows:

The main divider begins counting down from the “A” number. Then when zero is reached, it begins counting down from the “N” number until zero is reached. The cycle then repeats. While it is counting down the “A” number, the prescaler divides by 65, and while it is counting down the “N” number, it divides by 64.

To illustrate the operation of these dividers, an example will be used. Assume a transmit frequency of 813.4875 MHz is selected (800 MHz FCC channel 300). Since the VCO oscillates on the transmit frequency in the transmit mode, this is the frequency that must be produced by the VCO. To produce this frequency, the “N” and “A” divide numbers are programmed as follows:

$$N = 239 \qquad A = 13$$

To determine the overall divide number of the prescaler and main divider, the number of prescaler input pulses required to produce one main divider output pulse can be determined. Although the “N” number is 239 in this example, the actual divide number is always two higher (241) because of reset cycles and other effects. Therefore, the prescaler divides by 65 for 13 x 65 or 845 input pulses. It then divides by 64 for 241 x 64 or 15,424 input pulses.

Since the VCO frequency is not evenly divisible by 50 kHz, there is also a fractional-N number programmed that provides the required fractional divide number. In this example the fractional-N increment is  $.75 \times 8$  (modulo N) or 6. This causes the prescaler to divide by 65 for one additional output pulse for 6 of 8 main divider cycles. This produces a divide number that is  $.75$  higher. Therefore, with the preceding example, the overall divide number K is  $845 + 15,424 + .75$  or 16,269.75. The VCO frequency of 813.4875 MHz divided by 16,269.75 equals 50 kHz which is the  $f_R$  input to the phase detector.

*NOTE: The formulas for calculating the “N” and “A” divide numbers are described in Section 6.3.5.*

## 800/900 MHz RECEIVER DESCRIPTION

### 5.10.7 LOCK DETECT

When the synthesizer is locked on frequency, the LOCK output of U804 (pin 18) is a logic high voltage. Then when the synthesizer is unlocked, this voltage is low. A locked condition exists when the phase difference at the TCXO input is less than one cycle.

### 5.10.8 CHARGE PUMP

The charge pump circuit in U804 charges and discharges C833-C837 in the loop filter to produce the VCO control voltage. Resistors connected to the RN and RF pins set the charge current. The RF pin resistance is set by a digitally controlled potentiometer in U802. This resistance changes with the frequency band in order to minimize fractional-N spurious signals. The loop filter provides low-pass filtering which controls synthesizer stability and lockup time and suppresses the loop reference frequency (50 kHz).

### 5.10.9 SHIFT REGISTER (U800, U801) AND DIGITAL POTENTIOMETER (U802) PROGRAMMING

Shift register U800 functions as an I/O port expander, and shift register U801 functions as a D/A converter to provide a 256-step output voltage for adjusting transmitter power. In addition, the Q7 output of U801 provides the delayed transmit signal. U802 contains four digitally controlled potentiometers that are adjustable in 256 steps.

These devices are cascaded together on the serial bus so that data is shifted out of one device into another. Programming is performed using the SPI serial port of the microcontroller described in Section 5.3.1. The input to the internal shift register of these devices is the DATA (U800/U801) or SDI (U802) pin, and the output of the last shift register stage in U800 and U801 is the  $\overline{QS}$  pin. Therefore, serial data on the Data line from the audio/logic board (J201, pin 14) is first shifted into U801, then U800, and then U802.

Data is clocked through the devices by the CLOCK signal (J201, pin 13) when the STROBE input (J201, pin 12) is high and latched when it goes low. Synthesizer IC U804 is also programmed by the SPI port. However, data does not pass through the other devices because it is controlled by a different STROBE signal (J201, pin 1).

### 5.11 RECEIVER CIRCUIT DESCRIPTION (800/900 MHz MODELS)

*NOTE: The receiver block diagram is in Figure 5-7.*

#### 5.11.1 FRONT END FILTER

The receive signal is fed from the antenna switch circuit on the PA board to the receiver front end on the RF board. The signal is fed through a quarter-wave line that is part of the antenna switch as are C202, CR200, and R200. Refer to Section 5.12.3 for more antenna switch information. The receive signal is then applied to bandpass filter Z200. With 800 MHz models, this is a three-pole filter with a center frequency of 860 MHz and a bandwidth of 18 MHz. With 900 MHz models, it is a two-pole filter with a center frequency of 938 MHz and a bandwidth of 6 MHz. This filter attenuates frequencies outside the receive band such as the first injection, image, and half IF frequencies.

#### 5.11.2 RF AMPLIFIER (Q201)

RF amplifier Q201 improves and stabilizes receiver sensitivity and also recovers filter losses. A section of microstrip and C214 provide impedance matching on the input. CR203 protects the base-emitter junction of Q201 from damage caused by high level input signals.

The bias current of Q201 is fixed at a constant level by Q200. The collector current of Q201 flows through R207, and the voltage drop across that resistor (and therefore the current) is set by R205 and R206. For example, if current through R207 attempts to increase, the emitter voltage of Q200 decreases. Q200 then conducts less and turns Q201 off slightly to maintain a constant bias current. This provides a stable bias over changes in temperature.

The output signal of Q201 is fed to another bandpass filter similar to the one on the input described in the preceding section. Impedance matching with the filter is provided by a section of microstrip on the collector and C227. Resistor R209 lowers the Q of the microstrip to make it less frequency selective. C222-C226 decouple various unwanted AC signals from the circuit.

## 800/900 MHz RECEIVER DESCRIPTION

## 5.11.3 FIRST MIXER (Q202), CRYSTAL FILTER (Z204)

The signal from Z201 is then applied to mixer Q202. A 3-dB pad on the output of Z201 formed by R215-R217 sets the input level to the mixer. Impedance matching between the pad and mixer is provided by a section of microstrip and C245.

Q202 is biased by constant current source Q203 similar to Q200 described in the preceding section. The injection signal is applied to the emitter of Q202 and is at a level of approximately 10 dBm. With 800 MHz models, the injection frequency is 52.950 MHz below the receive frequency, and with 900 MHz models, it is 45 MHz below the receive frequency. Filtering of the injection signal is provided by two-pole bandpass filter Z203. With 800 MHz models, it has a center frequency of 807 MHz and a bandwidth of 18 MHz; and with 900 MHz models, it has a center frequency of 893 MHz and a bandwidth of 6 MHz.

The 52.950 or 45.000 MHz output signal of mixer Q202 is then applied to crystal filter Z204. Impedance matching between Q202 and 50-ohm, 3 dB pad R210-R212 is provided by L220, C231, and C232. Resistor R214 lowers the Q of L220 to make it less frequency selective. Matching between the pad and Z204 is provided by C265, C266, C268, and L213.

Z204 is a four-pole crystal filter. With 800 MHz models it has a center frequency of 52.950 MHz and a -3 dB bandwidth of 15 kHz, and with 900 MHz models it has a center frequency of 45 MHz and a -3 dB bandwidth of 7.5 kHz. This filter attenuates wideband noise, adjacent channels, frequencies resulting from intermodulation, and other undesired frequencies. Impedance matching between this filter and U201 is provided by C271, C272, L215, and R228.

## 5.11.4 SECOND MIXER/DETECTOR (U201)

Introduction

U201 contains second mixer, IF amplifier, detector, RSSI, and audio amplifier stages as shown in Figure 5-6 on page 5-19. The IF signal is applied to pin 1 which is the input of an internal IF amplifier stage.

Second Mixer

From the IF amplifier the signal is internally fed to the mixer which combines it with the 52.500 MHz (800 MHz models) or 44.550 MHz (900 MHz models) second injection frequency to produce a second IF of 450 kHz.

The injection frequency on pin 4 is produced by tripling the frequency of reference oscillator U806. To do this, part of the reference oscillator signal is applied to tripler Q207. This stage is an amplifier with the output tuned for the third harmonic of the reference oscillator frequency. This output tuning is provided by a two-pole bandpass filter formed by L219, C287, C288, L217, and C290. The output level of this filter is approximately 0.25 V rms.

Ceramic Filters (Z202/Z206, Z205)

The 450 kHz output of the internal mixer is fed out of U201 on pin 20 and routed to ceramic filter Z202 for all 900 MHz and 800 MHz narrow-band (12.5 kHz) channels, or Z206 for 800 MHz wideband (25 kHz) channels. Z202 has a nominal bandwidth at the -3 dB points of 8 kHz, and Z206 has a bandwidth of 15 kHz. The function of these filters is to attenuate wideband noise present in the IF signal.

Routing of the IF signal to the appropriate filter is provided by Q205 and Q206, PIN diodes CR207-CR210, and several resistors and capacitors. It is controlled by the microcontroller through the Q4 output of shift register U800. This output is low for narrow-band channels and high for wideband channels.

If a narrowband channel is selected, a low signal is applied to the base of Q205. That transistor is then turned off and inverter Q206 turned on. CR209/CR210 are then forward biased and CR207/CR208 reverse biased. This routes the 450 kHz IF signal through Z202 and blocks it from Z206. If a wideband channel is selected, the opposite occurs. For more information on the operation of PIN diodes, refer to Section 5.11.1.

The filtered 450 MHz IF signal is then applied to pin 18, amplified by an internal amplifier, and fed back out on pin 16 and applied to ceramic filter Z205.

## 800/900 MHz RECEIVER DESCRIPTION

This filter is identical to Z206 and provides additional attenuation of wideband noise. The loss introduced by each ceramic filter is approximately 12 dB.

### Limiter/Detector

The signal from Z205 is applied to an internal limiter connected to pin 14. The limiter amplifies the 450 kHz signal and then limits it to a specific value to remove amplitude variations. From the limiter, the signal is fed internally to the quadrature detector. An external phase shift network connected to pin 10 shifts the phase of one of the detector input signals 90° at 450 kHz (the other input is unshifted in phase). When modulation occurs, the frequency of the IF signal changes at an audio rate as does the phase of the shifted signal. The detector, which has no output with a 90° phase shift, converts this phase shift into an audio signal. L218 is tuned to provide maximum undistorted output from the detector.

The audio signal is then fed internally to an audio amplifier. The gain of this stage is set at about three by R255 and R256. The audio signal is then fed out on pin 8 and routed to the audio/logic board.

Also in U201 is an RSSI detector which provides a temperature compensated RSSI (Receive Signal Strength Indicator) signal on pin 5. This is a low impedance (2k ohm) output with a dynamic range of 70 dB. The DC voltage of this output changes in proportion to IF signal strength. This signal is routed to an A/D input of the microcontroller (pin 59) and used along with the squelch signal to determine receive signal strength. R259/C304 and R258/C303 provide low pass filtering of the audio and RSSI signals, and C305 and C306 decouple RF.

## 5.12 TRANSMITTER CIRCUIT DESCRIPTION (800/900 MHz MODELS)

*NOTE: The transmitter block diagram is located in Figure 5-7.*

### 5.12.1 PREDRIVER (Q506), DRIVER (Q507)

The input signal to the exciter is the transmit frequency from buffer amplifier Q801 in the synthe-

sizer. It is at a level of approximately 0 dBm and is applied to predriver Q506. Impedance matching on the input of Q506 is provided by C529, C515, two sections of microstrip (see description in Section 5.10.5), R518, and C516. Biasing is provided by R519, R520, R522, and R523. Various AC signals are decoupled from the DC supply by C520, C525, C526, C528, and C531.

The 8-volt supply voltage to this stage is switched on in the transmit mode by Q505 and Q504. This switch is controlled by the microcontroller through the Q7 output (pin 11) of shift register U801. This output is high in the transmit mode and low in the receive mode. This signal also controls the antenna switch circuit on the PA board described in Section 5.12.3.

This transmit 8V supply is not delayed which allows Q505 and the transmitter frequency to stabilize before power is produced. The delayed PTT signal is applied to the RF board on J201, pin 2. This signal controls the power control circuit described in Section 5.12.5. The emitters of Q503 and Q505 are grounded through Q509. That transistor is turned off when the logic is in an undetermined state such as during Flash programming. This ensures that the transmitter is turned off during these times.

From Q506 the transmit RF output signal is then applied to driver Q507. Impedance matching between Q506 and Q507 is provided by several capacitors and sections of microstrip and L501. Resistor R521 lowers the Q of the parallel microstrip which makes it less frequency selective. Q507 is biased for class C operation by L504 and ferrite bead EP501.

Supply voltage to Q507 is from the power control circuit described in Section 5.12.5. This circuit varies the supply voltage of Q507 which changes its power output to maintain constant transmitter power output. RF chokes L502 and L503, ferrite bead EP502, and several capacitors isolate the power control circuit from RF signals.

A 50-ohm, 3 dB pad formed by R529-R531 provides an output impedance of 50 ohms at the J602. Impedance matching between Q507 and this pad is provided by two sections of microstrip, C524, and C527. Power output at J602 is typically up to 250 milliwatts.



## 800/900 MHz TRANSMITTER DESCRIPTION

### 5.12.2 POWER AMPLIFIER MODULE (U600), FINAL (Q651)

Power amplifier module U600 on the PA board has approximately 19 dB of gain. Pins 2, 3, and 4 of U600 are the supply voltage inputs to three separate gain stages. The supply voltage on pin 2 (VS1) is switched by Q600 and limited to 12 volts by CR601 and R600. Switch Q600 is controlled by the same signal used to control 8V transmit switch Q505/Q504 (see Section 5.12.1).

The supply voltage applied to pins 3 and 4 (VS2/VS3) is the unswitched battery from the power jack fed through R601. Therefore, power is applied to these pins of U800 even when transceiver power is turned off. The power control circuit senses transmitter current by monitoring the voltage drop across R601.

The output signal on U600, pin 5 is then applied to Q651 (30 watt models only). With lower power models, Q651 is not used. Amplifier Q651 provides approximately 5 dB of gain. The output impedance on U600, pin 5 is 50 ohms, and it is matched to Q651 by a section of microstrip, C651, C652, and C653. Class C bias of Q651 is provided by L651. The unswitched battery supply applied to Q651 is isolated from RF by L602, EP601, and several capacitors. Impedance matching is provided on the output by C654-C656, C614, and two sections of microstrip.

### 5.12.3 ANTENNA SWITCH

The antenna switch circuit consists of Q602, CR602, CR604, several other components, and also a quarter-wave section of microstrip and CR200 on the RF board. This circuit switches the antenna to the receiver in the receive mode and the transmitter in the transmit mode.

Switching transistor Q602 is controlled by the transmit signal from the Q7 output (pin 11) of shift register U801. This is the same signal that controls transmit 8-volt supply switch Q505/Q504. This signal is high in the transmit mode and low in the receive mode. Therefore, Q602 turns on in the transmit mode and current flows from the collector of Q601 through R610, R609, CR604, L604, CR602/R602, and L602. In addition, 8 volts is applied through R200 to CR200 located at the input of the receiver on the RF board.

CR200, CR602 and CR604 are PIN diodes like CR901 described in Section 5.10.2. When a PIN diode is forward biased, it presents a very low impedance. Therefore, in the transmit mode the transmit signal has a low-impedance path to the antenna through CR602 and coupling capacitor C621.

The signal is blocked from the receiver by two grounded quarter-wave lines. A discrete quarter-wave line is formed by C635, C622, and L604 is effectively AC grounded on the receiver end by CR604 and C633. When one end of a quarter-wave line is grounded, the other end presents a high impedance to the quarter-wave frequency. Therefore, this line presents a high impedance into the receiver for the transmit signal. Further receiver isolation is provided by another quarter-wave line in the receiver. This line is grounded through C202 by CR200.

In the receive mode, all three PIN diodes are reverse biased. Therefore, CR602 presents a high impedance into the transmitter for the receive signal, and since the two quarter-wave lines into the receiver are no longer grounded, there is a low-impedance path into the receiver. L604 presents a low impedance because it is no longer grounded by CR604, and the quarter-wave line presents a low impedance because it is no longer grounded by CR200. Resistors R602 and R608 improve the isolation provided by CR602 and CR604 when they reverse biased (receive mode).

### 5.12.4 DIRECTIONAL COUPLER, LOW-PASS FILTER

A directional coupler is formed by adjacent sections of microstrip near C621. The forward component of output power is rectified by CR603 and developed across R606 and then fed to the power control circuit. Reverse power is not detected in this transceiver.

From the directional coupler the transmit signal is fed to a low-pass harmonic filter formed by C624-C627 and several sections of microstrip. This filter attenuates harmonic frequencies occurring above the transmit band. R607 dissipates static buildup on the antenna.

The ambient power amplifier temperature is sensed by thermistor R601. The resistance of a ther-

## 800/900 MHz TRANSMITTER DESCRIPTION

mistor decreases as temperature increases. This thermistor forms a voltage divider with R143 on the audio/logic board, and the voltage across this divider is monitored by an A/D converter input of the microcontroller (pin 63). If the PA temperature increases above limits set in software, the power is first cut back. Then if it continues to rise, the transmitter is turned off. Refer to Section 3.5.18 for more information.

### 5.12.5 POWER CONTROL (U500A/B, Q500-Q503)

#### Introduction

The power control circuit maintains a constant power output as changes occur in temperature and voltage. It does this by varying the supply voltage to driver Q507. This changes the power output of that stage which in turn controls the power output of the transmitter.

The primary signal sensed to control power output is forward power from the directional coupler. The current to final amplifier Q601 is also sensed, but it affects power output only if it becomes excessive. Gradual power shutdown then occurs.

The power output level is set in 127 steps by the microcontroller through D/A converter U801. This allows power to be adjusted from the front panel using the test mode and also different power levels to be programmed for each system. In addition, it allows the microcontroller to cut back power when power amplifier temperature or transceiver voltage is excessive as just described in Section 5.12.4.

#### U500A, Q500/Q502 Operation

U500A is a differential amplifier which amplifies the difference between the reference voltage on pin 3 and the forward power signal on pin 2. The forward power signal from the directional coupler is a DC signal that increases in proportion to forward power. The reference input is a DC voltage from the D/A converter formed by shift register U801 and several resistors. This stage is similar to U305 described in Section 5.4.4, and programming of U801 is described in Section 5.10.9. This reference voltage effectively sets the power output of the transmitter.

The turn-on time of U500A is controlled by the time constant of C502 and R508. Negative AC feedback to prevent oscillation is also provided by C502. This circuit operates as follows: Assume the output power attempts to increase. The DC voltage applied to U500A, pin 2 then increases which causes the output voltage on pin 1 to decrease. Transistors Q502 and Q500 then turn off slightly which decreases the supply voltage to driver Q507. The output power then decreases to maintain a constant power output. R510 and R513 limit the voltage gain of Q500 and Q503 to approximately two.

#### Delayed PTT

Transistor Q503 is used to delay power output for a short time after the transmitter is keyed. This allows the synthesizer, Q506 in the exciter, and the first stage of PA module U600 to stabilize so that the transmitter does not transmit off-frequency. The signal which controls Q503 is from the Q2 output (pin 17) of latch U111 on the audio/logic board. In the receive mode, this output is low which turns Q503 off. U500A, pin 2, is then pulled high by 8 volts applied through R505 and CR503. The output of U500A on pin 1 is then low which shuts off power to Q507. Then when the transmitter is keyed, Q503 turns on after a short delay and diode CR503 is no longer forward biased. Only the forward power signal is then applied to pin 2 of U500A.

#### Over Current Shutdown

Current to the second and third amplifier stages in power module U600 on the PA board is monitored by sensing the voltage drop across R601. Pins 5 and 6 of U500B are effectively connected across this resistor. As current increases, the voltage on U500B, pin 6 decreases which causes the output voltage on pin 7 to increase. The gain of each U500B input is set at about ten by R509/R504 and R502/R507.

Emitter biasing for Q501 is provided by R506 and R511. Normally, the output voltage of U500B is not high enough to turn on Q501. However, if current becomes excessive, for example because of an antenna mismatch, Q501 begins turning on. This decreases the base voltage of Q502 which turns off Q500 slightly and cuts back power output. Over-current shutdown is disabled in 15-watt models because CR500 is not used.

## SECTION 6 SERVICING

### 6.1 GENERAL

#### CAUTION

*LTR-Net™ models (see Sections 1.3 and 1.4) may automatically transmit during normal operation and at power off to send registration and de-registration messages. Therefore, to prevent accidental damage to a signal generator attached to these models, be sure to use an adequate isolation pad.*

#### 6.1.1 PERIODIC CHECKS

This transceiver should be placed on a periodic maintenance schedule to ensure that it continues to operate properly. Important checks are receiver sensitivity and transmitter frequency, deviation, and power output. Performance tests are located in Sections 7.4 and 7.5.

#### 6.1.2 SCHEMATIC DIAGRAMS AND COMPONENT LAYOUTS

Schematic diagrams and component layouts for the various PC boards used in this transceiver are located in the back of this manual. Included are RF and audio/logic board and interconnect schematics.

The component layouts permit easy location of components and measurement points. For the RF and audio/logic boards, a component locator guide and grid around the boards are provided to aid in locating components. All boards in this transceiver have components mounted on one side only. Therefore, most servicing can be done without removing the board from the chassis.

#### 6.1.3 REPLACEMENT PARTS

A replacement parts list for this transceiver is located in Section 8. The main listing includes the RF board and chassis parts and another listing includes the audio/logic board parts. Parts are listed alphabetically according to designator. For information on ordering parts, refer to Section 1.9. An exploded view of the transceiver is also included at the end of Section 8 to show the various mechanical parts.

#### 6.1.4 CONFIGURING TRANSCEIVER FOR TESTING

This transceiver has a test mode which can be selected to perform testing. The test mode is described in Section 3.11, and it permits the transceiver to be operated manually. To select the test mode, turn power on with the following option switch(es) pressed. The test mode is especially useful when only LTR operation is programmed because the receiver and transmitter are then inhibited until a handshake is completed with a repeater.

Low Tier Models - Top (A/D) switch

High Tier Models - Top two switches (to right of display)

If adjustments must be made to the various audio and data levels, the programming setup and special Radio Tune software are required as described in Section 1.2.7. The procedure for aligning the transceiver is located in Section 7.

### 6.2 SURFACE MOUNTED DEVICES (SMDs)

#### 6.2.1 SERVICING TECHNIQUES

Most of the components used in this transceiver are the surface mounted type. Since these components and the circuit traces on which they are mounted are very small in size, special care must be used when they are replaced. Multi-leaded components such as integrated circuits must usually be removed using a heat gun or some other type of heat source that heats the entire device. Take care so that nearby components are not damaged. Surface mounted components should not be reused since they may be damaged by the unsoldering process.

#### 6.2.2 IDENTIFYING SMD RESISTORS

The value of resistors is indicated by a number printed on the resistor. A three-digit number is used to identify  $\pm 5\%$  and  $\pm 10\%$  resistors, and a four-digit number is used to identify  $\pm 1\%$  resistors. Refer to the following information.

± 5% And ± 10% Resistors (P.N. 569-0105-xxx)

The three-digit number used to identify ±5% and ±10% resistors corresponds to the last three digits of the EFJohnson part number. This number is derived as follows. For example, “273” indicates a 27k ohm resistor and “339” indicates a 3.3 ohm resistor.

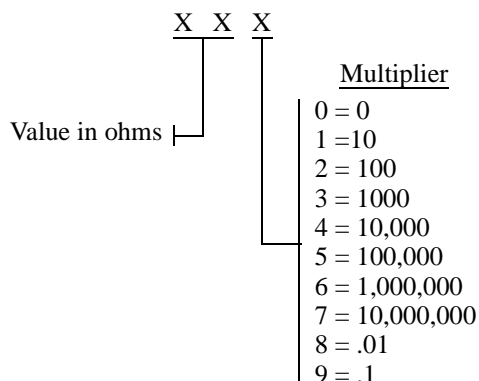

± 1% Resistors (P.N. 569-0111-xxx)

Some resistors with a ±1% tolerance are identified by a four-digit number and others may not have a marking. When identified with a four-digit number, the first three digits are the value and the fourth is the multiplier. For example, “5761” indicates a 5.76k ohm resistor.

6.2.3 SMD CAPACITOR IDENTIFICATION

Ceramic SMD Capacitors (P.N. 510-36xx-xxx)

Ceramic SMD capacitors are identified using either an American or Japanese EIA standard. The American standard uses a single letter or number to indicate the value, and the color of this letter or number to indicate the multiplier. The Japanese standard uses a letter to indicate the value followed by a number to indicate the multiplier. The values for both standards are shown in the following table. For example, if there is a single black “E” on the capacitor, it uses the American standard and its value is 15 pF. The same value is identified with the Japanese standard by “E1”.

The Japanese standard may also utilize a bar to indicate the temperature coefficient. The following

coefficients are indicated by this bar. For example, “A2” indicates a 100 pF NPO capacitor.

$\overline{XX} = \text{NPO}$      $\overline{XX} = \text{N150}$      $\overline{XX} = \text{N220}$

$\underline{XX} = \text{N330}$      $\underline{XX} = \text{N470}$      $\underline{XX} = \text{N750}$

$|XX = \text{X7R}$

Table 6-1 Ceramic SMD Capacitor Identification

American EIA Standard		Japanese EIA Standard	
First Letter/ Number	Value (pF)	First Letter/ Number	Value (pF)
A	10	A	1.0
B	11	B	1.1
C	12	C	1.2
D	13	D	1.3
E	15	E	1.5
H	16	F	1.6
I	18	G	1.8
J	20	H	2.0
K	22	J	2.2
L	24	K	2.4
N	27	L	2.7
O	30	M	3.0
R	33	N	3.3
S	36	P	3.6
T	39	Q	3.9
V	43	R	4.3
W	47	S	4.7
X	51	T	5.1
Y	56	U	5.6
Z	62	V	6.2
3	68	W	6.8
4	75	X	7.5
7	82	Y	8.2
9	91	Z	9.1
Color	Multi-plier	Second Number	Multi-plier
Orange	0.1	0	1
Black	1	1	10
Green	10	2	100
Blue	100	3	1000
Violet	1000	4	10,000
Red	10,000	5	100,000

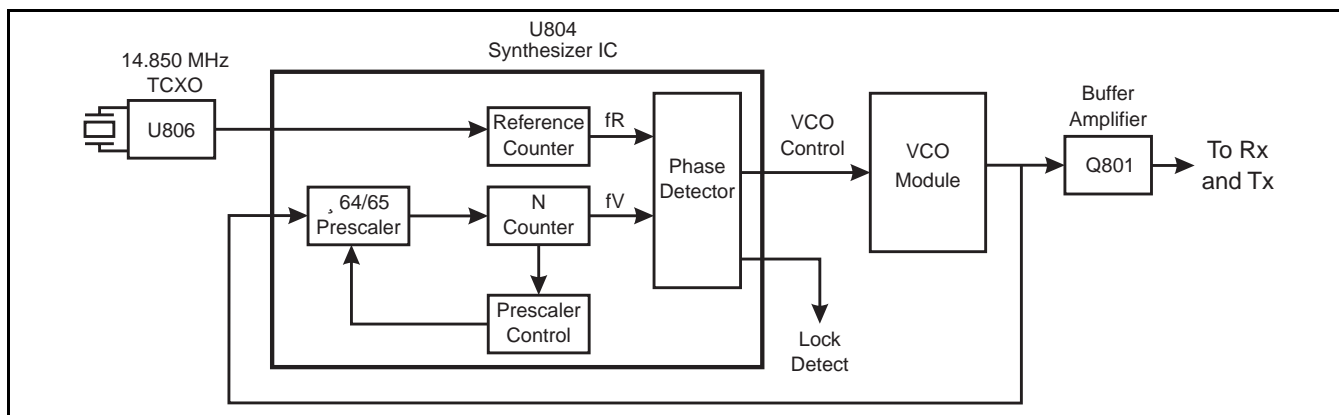

Figure 6-1 Simplified Synthesizer Block Diagram

Tantalum SMD Capacitors (P.N. 510-26xx-xxx)

Tantalum SMD capacitor identification varies with vendor and physical size of the capacitor. The positive (+) end is usually indicated by a colored band or beveled edge. The value and voltage may be indicated by printing on the capacitor or by using a special code.

6.2.4 SMD INDUCTOR IDENTIFICATION

SMD inductors (P.N. 542-9000-xxx) use three colored dots to indicate the value. The two dots on the left side indicate the first and second digits of the value in nanohenries, and the single dot on the right side indicates the multiplier (see Table 6-2). For example, brown, black, and red dots indicate a value of 10 nH x 100 which is 1000 nH (1.0 μH). The last three digits of the part number are also the value and multiplier.

6.2.5 TRANSISTOR/DIODE IDENTIFICATION

Surface mounted transistors and diodes are identified by a special number. Refer to page 9-1 for more information.

6.3 SYNTHESIZER TROUBLESHOOTING

6.3.1 INTRODUCTION

When there is a synthesizer malfunction, the VCO is usually not locked on frequency. When the VCO is unlocked, the LOCK output on U804, pin 18, is low. This is detected by the logic which then displays only the middle segment of the seven-

Table 6-2 SMD Inductor Identification

Color	1st Digit	2nd Digit	Multiplier (Last PN Digit)
Black	0	0	1 (7)
Brown	1	1	10 (8)
Red	2	2	100 (9)
Orange	3	3	1000 (0)
Yellow	4	4	10,000 (1)
Green	5	5	100,000 (2)
Blue	6	6	---
Violet	7	7	---
Gray	8	8	---
White	9	9	0.1 (6)

segment display (low tier) or “OUT-LOCK” (high tier) and disables both the transmitter and receiver.

When the VCO is unlocked, the fR and fV inputs to the phase detector in U804 are usually not the same frequency (see Figure 6-1). The phase detector in U804 then causes the VCO control voltage to go to the high or low end of its operating range. This, in turn, causes the VCO to oscillate at the high or low end of its frequency range.

As shown in Figure 6-1, a loop is formed by the VCO and the prescaler, N counter, and phase detector in U804. Therefore, if any of these components malfunction, improper signals appear throughout the loop. However, correct operation of the counters can still be verified by measuring the input and output frequencies to check the divide number. Proceed as follows:

### 6.3.2 REFERENCE OSCILLATOR (U806)

Check the signal at U806, pin 8. With 800 MHz models, it should be 17.500 MHz, and with UHF and 900 MHz models, 14.850 MHz. The level should be approximately 400 mV rms. If this signal is not present, replace the reference oscillator because it is not serviceable.

Mode	Shift 1 (Pin 4)	Shift 2 (Pin 3)
<b>UHF MODELS</b>		
Rx Mode 430-449 MHz	L	L
449-470 MHz	H	L
470-491 MHz	L	L
491-512 MHz	H	L
Tx Mode 430-449 MHz	L	H
449-470 MHz	H	H
470-491 MHz	L	H
491-512 MHz	H	H
<b>800/900 MHz MODELS</b>		
Normal Mode	H	L
Talk-around Mode	L	H

### 6.3.3 VCO MODULE

The VCO is a separate assembly that is covered by a metal shield and soldered directly to the RF PC board. This module cannot be repaired. One reason for this is that the center frequency is set by laser tuning ceramic resonator L101 (UHF) or L907 (800/900 MHz) and cannot be readjusted if it changes as a result of changing a part. In addition, the VCO has a ceramic substrate that can easily be damaged by excessive heat. It is also recommended that modules that have been removed using a standard soldering iron not be reused.

Perform the following checks on the VCO module to determine if it is defective.

**Supply Voltage** - The supply voltage at pin 15 should be 5.0 VDC (UHF) or 7.0 VDC (800/900 MHz).

**Output Level** - The output level on pins 1 or 2 can be measured with an RF voltmeter or some other type of high-impedance meter. The typical output level at these points should be 0 dBm.

**Control Voltage** - Check the DC voltage on pin 7 with a channel near the middle of the band selected. If the VCO is locked on frequency, it should be a steady voltage between 1.1 and 5.2 volts. If it is not locked on frequency, it should be near the lower (1.1 V) or upper (5.2 V) end of its range.

**Frequency Shift Inputs** - The pin shift signals on pins 4 and 3 should be as follows (L = 0V, H = 5V):

**Frequency** - If the VCO is locked on frequency, in the receive mode the output frequency should be the receive frequency – 52.950 MHz (800 MHz models) or the receive frequency – 45 MHz (UHF and 900 MHz models). In the transmit mode it should be the transmit frequency. If it is not locked on frequency, it should be near the low end of its operating frequency range when the control voltage is low and near the high end of its range when the control voltage is high.

### 6.3.4 SYNTHESIZER IC (U804)

Since U804 does not have output pins from the various counters, their operation cannot be checked. However, the following signals can be checked to verify proper operation of U804.

**Ref Osc In (pin 8)** - Check the reference oscillator output frequency and level as described in Section 6.3.2.

**VCO RF In (pin 6)** - Check the VCO output as described in the preceding section.

**VCO Control Voltage (pins 13, 14)** - If the VCO frequency is too low, the signal on these pins should be high with very narrow negative-going pulses. Conversely, if the VCO frequency is too high, the signal should be low with very narrow positive-going pulses.

**Lock Detect Output (pin 18)** - This output should be high when the synthesizer is locked on frequency and low when it is unlocked.

### 6.3.5 DETERMINING SYNTHESIZER COUNTER DIVIDE NUMBERS

*NOTE: For more information on the operation of the counters in U801, refer to Section 5.7.5.*

**Overall Div No. (K) = VCO freq  $\div$  .050**

Example:  $813.4875 \div .050 = 16,269.75$

**“A” Divide No. = 64 x Fraction (Integer K  $\div$  64)**

Example:  $16,269 \div 64 = 254.20312$   
 Fraction  $254.20312 = 0.20312$   
 $64 \times 0.20312 = 13$

**“N” Divide No. = Integer [K  $\div$  64] – A**

Example: Integer  $254.20312 = 254$   
 $254 - 13 = 241$

**Fractional-N Div No. = (Fraction K) x 8**

Example: Fraction  $16,269.75 = 0.75$   
 $0.75 \times 8 = 6$

### 6.4 RECEIVER SERVICING

To isolate a receiver problem to a specific section, check the DC and RF voltages shown on the schematic diagram.

With UHF models only, the front end filter frequency shift inputs on U800, pins 6 and 7 should be as follows (L = 0V, H = 5V):

Frequency	Shift F1 (Pin 6)	Shift F2 (Pin 7)
430-440 MHz	H	H
440-450 MHz	L	H
450-460 MHz	H	L
460-470 MHz	L	L
470-480 MHz	H	H
480-491 MHz	L	H
491-502 MHz	H	L
502-512 MHz	L	L

### 6.5 TRANSMITTER SERVICING

To isolate a transmitter problem to a specific stage, check the DC and RF voltages shown on the schematic diagram.

### 6.6 AUDIO/LOGIC BOARD SERVICING

#### 6.6.1 DIGITAL CIRCUITS

Because of the complexity and dynamic operation of the digital portion of the audio/logic board, servicing may be difficult. Special test equipment and knowledge of the operating software are usually needed to isolate a problem. Therefore, if a problem is suspected with the digital circuitry, it may be best to first make sure that the proper supply voltages are present and then replace the audio/logic board.

#### 6.6.2 ANALOG CIRCUITS

The analog circuits on the audio/logic board can be checked by measuring the AC and DC voltages shown on the schematic diagram.

## SECTION 7 ALIGNMENT PROCEDURE AND PERFORMANCE TESTS

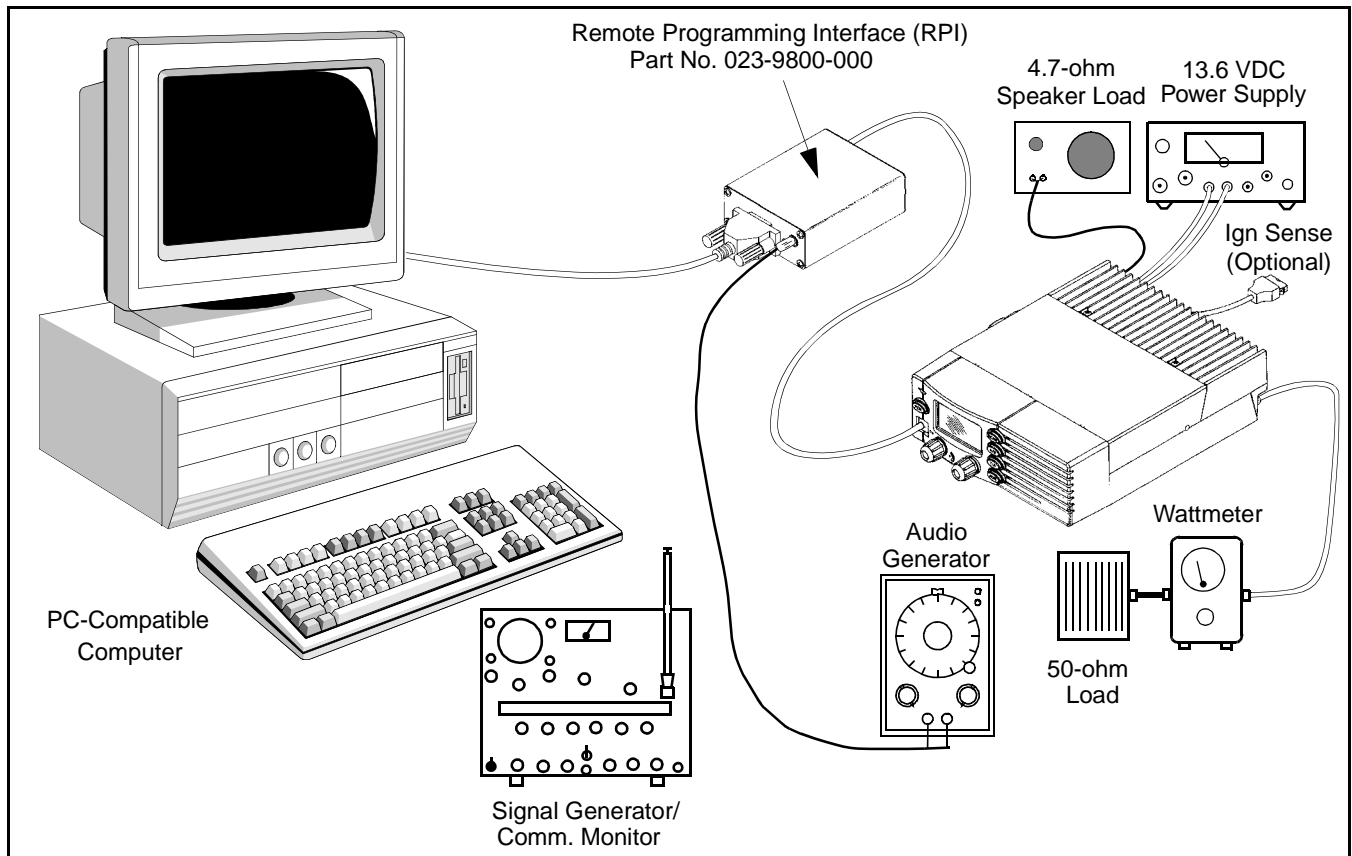

Figure 7-1 Alignment Setup

## 7.1 GENERAL

## 7.1.1 INTRODUCTION

The following alignment should be performed if repairs are made that could affect the factory alignment. In addition, before a transceiver is initially placed in service, the performance tests in Sections 7.4 and 7.5 should be performed.

Depending on the model, there are only two, three, or four adjustments that are made manually. All others are set digitally by the microcontroller and then the settings are stored in memory. Since the manual adjustments seldom need to be reset, the transceiver can usually be aligned without removing the covers.

To perform transceiver alignment, special Tune software (see Section 7.2) and the same basic

computer/RPI setup used to program personality information are required. This equipment is shown in the above illustration and described in Section 4.1. Only Remote Programming Interface, Part No. 023-9800-000, can be used for tuning because it is the only RPI that has the miniature phone jack for injecting the microphone audio signal.

## 7.1.2 TEST MODE

*NOTE: The test mode is required only for the performance tests described in Sections 7.4 and 7.5.*

To select the test mode, turn power on with the following option switch(es) pressed:

Low Tier Models - Top (A/D) switch

High Tier Models - Top two switches (to right of display)



In the test mode, test channels and various modulation signals can be manually selected. The test channels are either default channels or others can be programmed as described in Section 4.6.2. For a complete description of test mode features and operation, refer to Section 3.11.

### 7.1.3 TEST SETUP

Connect the test setup shown in Figure 7-1. The following is additional information on equipment in this setup.

**RF Signal Generator** - When connecting the generator to the antenna jack, use at least a 6 dB pad between the generator and transceiver. This protects the generator in case the transmitter is accidentally keyed and also ensures that a 50-ohm load exists. The generator output levels in the following procedure are input levels into the transceiver, not into a 6 dB pad.

**Power Supply** - It must provide at least 15 amperes with 30 and 40 watt models and 7 amperes with 15 and 25 watt models. The input voltage must be 13.6 VDC at the transceiver.

**Wattmeter/Load** - Must be capable of measuring and dissipating up to 50 watts.

**Audio Generator** - The RPI has a miniature phone jack (similar to the transceiver external speaker jack) for connecting the transmit audio signal.

**Speaker Load** - It should be 4.7 ohms and capable of dissipating at least 5 watts.

*NOTE: The speaker outputs are floating. Therefore, make sure any meter connected across the speaker load has floating inputs. (Although the audio amplifier is internally protected from damage caused by shorting either output to ground or B+, doing so should be avoided.)*

**Ignition Sense** - If the transceiver is equipped with the optional accessory pigtail and senses the ignition switch, the ignition sense input must be connected to 13.6 VDC for the transceiver to operate. Refer to Section 2.4 for more information.

**Computer and RPI** - The RPI is connected to the computer and transceiver as described in Section 4.1.6.

## 7.2 USING TUNE SOFTWARE

### 7.2.1 GENERAL

*NOTE: Tuning software Version 203 or later is required to tune LTR-Net upgradable models running Version 209 or later operating software (the version number is displayed briefly on the opening screen). Refer to Appendix C for more information.*

The special Tune software listed in Table 1-3 of Section 1 is required to perform most adjustments in this section. The only adjustments that could be performed without this software are the manual adjustments described in Sections 7.3.2 and 7.3.8.

The Tune program is a relatively small DOS program and therefore can be run on computers which may have limited memory or processor power (by today's standards). However, at least MS-DOS 5 and a 286 processor are required as described in Section 4.1.2. If your computer is equipped with Windows 3.x, 95, or NT, it may run properly under that operating system. If it does not, run it in the DOS mode.

### 7.2.2 INSTALLATION

The Tune program comes uncompressed on a single floppy disk. The file is called PLATTUNE.EXE and it is about 400K in size. No other files are required with this program. To install this software on your hard drive, use the procedure in Section 4.2.3 as a general guide. The program defaults to serial port 1 (COM1). If the RPI is connected to serial port 2 instead, it must be changed in the program as described in the next section.

### 7.2.3 PROGRAM OPERATION

To start the program from DOS, make the directory of the program the current directory and type PLATTUNE. From Windows 95, double click the shortcut icon for the program if one has been created. The opening screen is shown in Figure 7-2. Use the arrow keys or the indicated number keys to highlight the desired function and then select it by pressing the

Enter key. The following information describes the functions that can be selected.

**1. Radio Serial Number** - Reads the serial number stored in permanent memory of the transceiver. This number cannot be changed and is the same as the identification number described in Section 1.4.

**2. Tune Radio** - Displays the Radio Tuner menu shown in Figure 7-3. Refer to Section 7.2.4 for more information on the functions in this menu.

**3. Change COM Port** - Displays a screen that selects the port that is connected to the RPI. The default is COM1. If this must be changed (COM2 is used instead), this function needs to be used only the first time the program is run. The selected COM port and color mode (see following F9 description) are stored in the RADIOTUN.CFG file which is loaded each time the program is started.

**4. Display Tune Parameters** - Uploads the current tune parameters stored in the transceiver and displays them in a table similar to the one shown below.

Current Tune Settings					
Radio Serial Number					98834A527A00015
Power	High Power	Low Power 1	Low Power 2	Low Power 3	Low Power 4
806.000000	32	11	6	4	3
870.000000	32				
Mod Balance					
806.000000	810.000000	814.000000	817.000000	821.000000	
152	151	150	148	148	
825.000000	851.000000	857.000000	864.000000	870.000000	
146	124	120	116	113	
Deviation	825.000000	870.000000	Receiver Parameters		
Audio WB	201	197	Squelch WB	44	
NB	99	87	Squelch NB	16	
Data WB	207	202	RSSI WB	33	
NB	187	181	RSSI NB	34	
NPSPEC	181				
Press any key to exit.					

**5. Quit** - Exits program.

**F9** - Toggles between the monochrome and color modes.

**ESC** - To exit out of the current menu or function, press the Escape key.

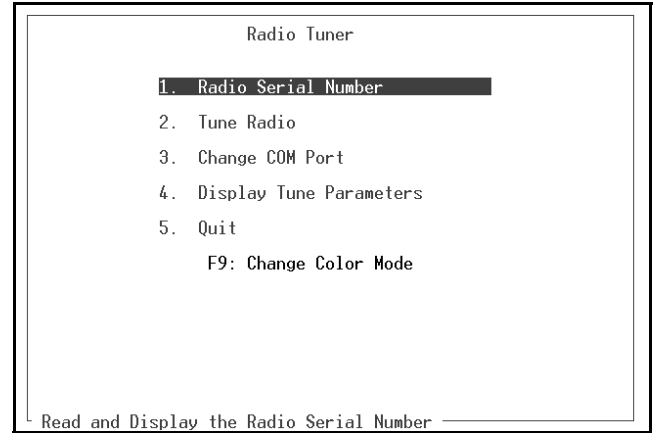

Figure 7-2 Tune Program Opening Screen

### 7.2.4 TUNE RADIO SCREEN

When transceiver alignment is to be performed, “Tune Radio” is selected in the Figure 7-2 screen as described in the preceding section. The screen in Figure 7-3 is then displayed.

If you want to have the program automatically go from one adjustment to the next, select “Radio Tune”. Conversely, if you want to manually select adjustments one at a time, select them individually from items 2-9.

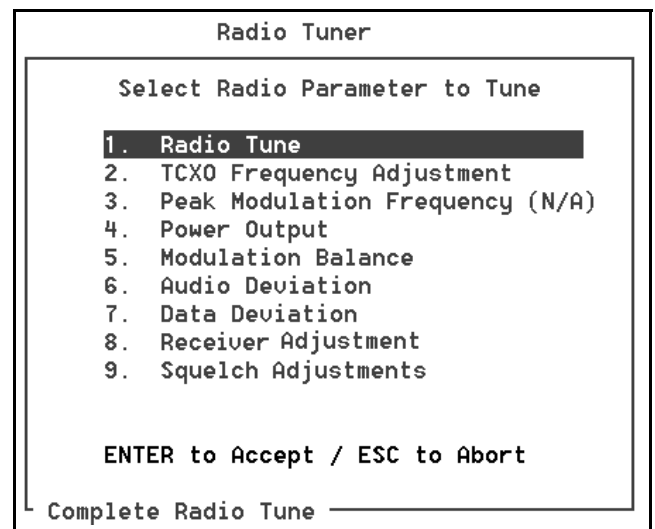

Figure 7-3 Radio Tuner Menu

### 7.3 ADJUSTMENT PROCEDURE

#### 7.3.1 PRELIMINARY

The following adjustments are made with the computer and RPI connected to the transceiver as described in Section 7.1. Proceed as follows:

1. Connect this test setup described in Section 7.1.3, turn transceiver power on, and start the Tune program as described in Section 7.2.3.
2. The opening screen shown in Figure 7-2 is then displayed. From this screen select “Tune Radio” to automatically go from one adjustment to the next, or select the adjustments one at a time.

#### 7.3.2 FREQUENCY AND BIAS ADJUSTMENT

1. Remove the top cover to access the RF board. Connect a 50-ohm load to the antenna jack and monitor the transmit frequency with a communication monitor.
2. Manually select “TCXO Frequency Adjustment” or automatically select “Reference Frequency Adjustment”.
3. Manually adjust the variable capacitor in reference oscillator U806 for the displayed frequency  $\pm 100$  Hz (see Figure 7-4).
4. With UHF 470-512 MHz models only, connect a DC voltmeter to the junction of L505 and C529 (see following illustration). Then adjust R527 for a meter reading of 3.00 volts (with transmitter keyed).

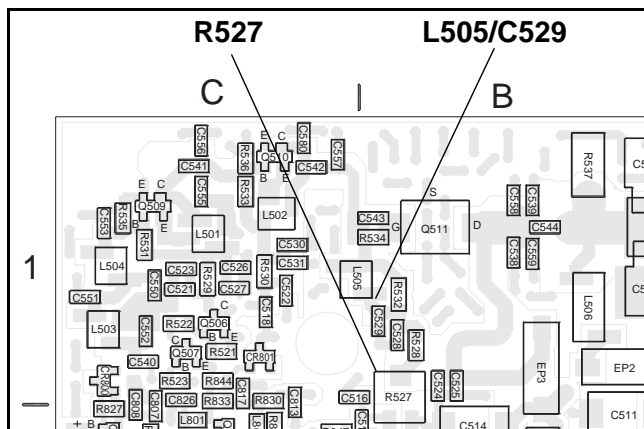

**UHF 470-512 MHz Adjustment Points**

#### 7.3.3 MODULATION PEAK FREQUENCY (UHF MODELS ONLY)

1. Manually select “Peak Modulation Frequency” or automatically select “Tune Modulation Peak Frequency”.
2. Apply a 1 kHz, 1 volt rms, AC coupled signal to the transmit audio input jack of the RPI as shown in Figure 7-1.
3. Monitor the transmit modulation signal with a communications monitor. If applicable, set the monitor high-pass filter for 50 kHz and the low-pass filter for 15 kHz.
4. Follow the instructions on the screen to select the frequency with the highest deviation. Remove the 1 kHz injection signal.

#### 7.3.4 POWER OUTPUT

This adjustment sets the power output selected by the power output setting programmed for each system. With low tier models, high and low settings are available, and with high tier models, high, low 1, low 2, low 3, and low 4 setting are available.

1. Connect a wattmeter and antenna load to the antenna jack as shown in Figure 7-1.
2. Manually select “Power Output” or automatically select “High Power Output”.
3. Follow the instructions on the screen and set the High Power Level on the low and high channels for a value within the range which follows (both channels must be set the same).

Model*	Power Setting Range
25 Watt UHF	2-25 Watts
40 Watt UHF	10-40 Watts
15 Watt 800/900 MHz	2-15 Watts
30 Watt 800/900 MHz	10-30 Watts

\* The transceiver power output is indicated by the fifth digit of the transceiver identification (serial) number as follows: 0/1/4/6/8 = 15 or 25W, 2/3/5/7/9 = 30 or 40W (see Section 1.4).

- Continue with the instructions on the screen to set the Low Power Level for a value within the preceding ranges. One low power level can be programmed with low tier models, and four levels can be programmed with high tier models.

### 7.3.5 MODULATION BALANCE

- Manually select “Modulation Balance” or automatically select “Tune Modulation Balance”.
- Connect a 50-ohm load to the antenna jack and view the transmit modulation waveform on the CRT of a communication monitor. If applicable, set the monitor for de-emphasis off, high-pass filter off, low-pass filter 3 kHz, and FM peak detection active.
- Set the monitor for the indicated frequency and follow the instructions to adjust for the best demodulated square wave with minimum tilt and overshoot. Repeat for the other standard and talk-around frequencies indicated.

### 7.3.6 TRANSMIT AUDIO LIMITING

- Manually select “Audio Deviation” or automatically select “Transmitter Audio Deviation”.
- Apply a 1 kHz, 1 volt rms, AC coupled signal to the transmit audio input jack of the RPI as shown in Figure 7-1.
- Monitor the transmit modulation signal with a communications monitor. If applicable, set the monitor high-pass filter for 50 kHz and the low-pass filter for 15 kHz.
- Follow the instructions on the screen and set wideband (UHF and 800 MHz only) deviation for 3.7 kHz  $\pm$ 50 Hz and narrowband deviation for 1.5 kHz  $\pm$ 50 Hz on the low and high channels. With 800 MHz models, the NPSPAC channel deviation is also set for 2.9 kHz  $\pm$ 50 Hz. Remove the 1 kHz injection signal.

### 7.3.7 TRANSMIT DATA LEVEL

- Manually select “Data Deviation” or automatically select “Transmitter Data Deviation”.

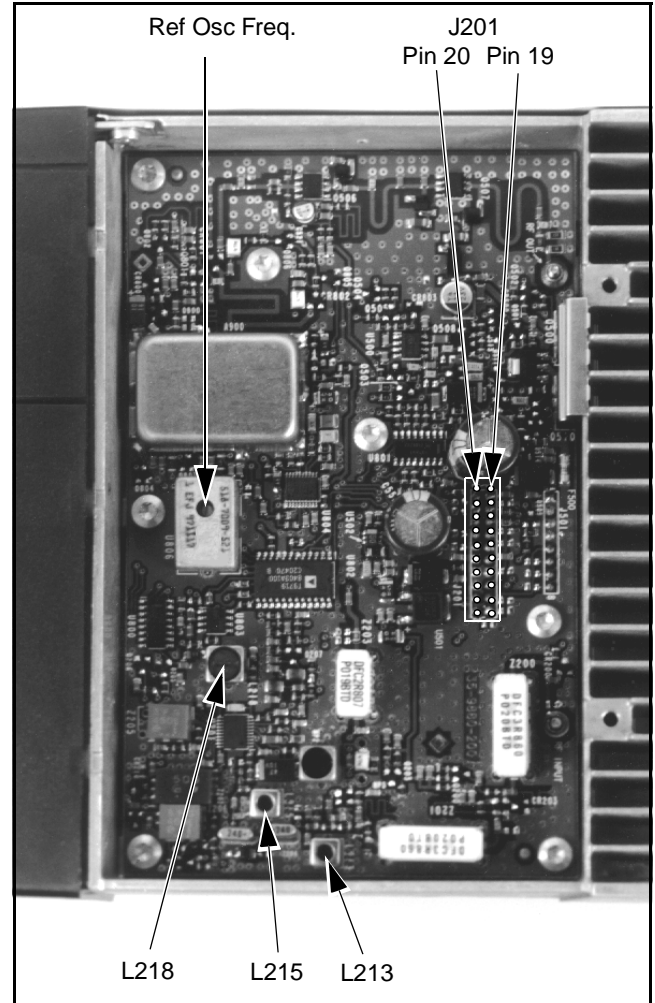

**Figure 7-4 Alignment Points Diagram**

- Continue monitoring the transmit modulation signal with a communications monitor set the same as in the preceding section.
- Follow the instructions on the screen and set the wideband (UHF and 800 MHz only) deviation for 1000 Hz  $\pm$ 50 Hz and the narrowband deviation for 800 Hz  $\pm$ 50 Hz on the low and high channels.

### 7.3.8 RECEIVER IF ADJUSTMENT

- Manually or automatically select “Receiver Adjustment”.
- Connect an RF signal generator to the antenna jack using a 6 dB or greater pad. Set the generator output for the displayed frequency, modulated with 1 kHz at 3 kHz deviation.

3. Remove the top cover. Connect a DC voltmeter to J201, pin 19 (see Figure 7-4).
4. Set the generator output level for  $-80$  dBm ( $22 \mu\text{V}$ ) at the antenna jack. Manually adjust L213 and L215 for a maximum meter reading.
5. Set the generator output level for  $-47$  dBm ( $1.0 \text{ mV}$ ) at the antenna jack. Connect the DC voltmeter to J201, pin 20. Manually adjust L218 for a meter reading of  $2.9 \text{ V} \pm 0.1 \text{ V}$ .
2. Connect an RF signal generator to the antenna jack (see Section 7.1.3). Set the generator output for the displayed frequency, output level, and modulation.
3. Connect a 4.7-ohm speaker load to the external speaker jack as shown in Figure 7-1. Connect a SINAD meter across the load (make sure it has floating inputs).
4. Adjust the volume control to approximately 1/3 of maximum. Adjust the generator output level for SINAD level indicated on the screen.

### 7.3.9 SQUELCH LEVEL ADJUST

The tune software automatically detects if the transceiver has the improved RSSI squelch or standard squelch and then selects the applicable squelch tuning procedure (see “NOTE” in Section 7.2.1). Proceed as follows:

1. Manually select “Squelch Adjustments” or automatically select “Receiver Squelch Setting”.

5. Follow the instructions on the screen to complete the squelch adjustment.

## PERFORMANCE TESTS

*NOTE: The computer and RPI are not required to perform the following tests.*

### 7.4 RECEIVER PERFORMANCE TESTS

1. Connect the RF signal generator to the antenna jack and a 4.7 ohm speaker load to the external speaker jack (see Section 7.1.3 for more test setup information).
2. Select the test mode by turning power on with the A/D switch pressed (low tier) or with the upper two option switches pressed (high tier). Select a channel on the low end of the band, the narrowband mode, and Group 1 for normal carrier squelch operation. Refer to Section 3.11 for more test mode information.
3. Set the generator for the channel frequency with an output level of 1 mV (−47 dbm) modulated with 1 kHz at 1.5 kHz deviation. Adjust the volume control for 4.85 V rms across the 4.7-ohm load. Distortion should be less than 3%.
4. Decrease the generator output to obtain 12 dB SINAD. The generator output should be 0.35  $\mu$ V (−116 dBm) maximum.
5. Also check the channels near the middle and high end of the band. If the transceiver can also be used for wideband channels, change the generator modulation to 3 kHz, select the wideband mode (see Section 3.11), and repeat the preceding tests.

### 7.5 TRANSMITTER PERFORMANCE TESTS

#### 7.5.1 CHECKING POWER OUTPUT

1. Connect the wattmeter and antenna load to the antenna jack. See Section 7.1.3 for additional test setup information.
2. If applicable, select the test mode as described in step 2 of preceding section. Select a channel on the

low end of the band and Group 1 so that no subaudible signaling is generated.

3. Select high power output by pressing the SCAN key (upper option key). High power output is indicated with low tier models when the green LED is off and with high tier models when **P** is not displayed. Key the transmitter and note the power output. It should be the level set as described in Section 7.3.4, step 3, −0 watt, +4 watts.
4. Press the SCAN/upper key to select low power. It should be the low level set as described in Section 7.3.4, step 4, −0 watt, +0.5 watt.
5. Also check power output on middle and high channels.

#### 7.5.2 CHECKING FREQUENCY

Monitor the transmit frequency with a communications monitor. It should be within 1.5 PPM (at room temperature, it should be within  $\pm$  200 Hz). This also checks the receive frequency.

#### 7.5.3 CHECKING DEVIATION

1. Select a channel on the low end of the band, the narrowband mode, and Group 2 to generate 134 Hz data modulation signal (refer to Section 3.11 for more test mode information).
2. Key the transmitter and monitor the deviation with a communications monitor. Deviation should be 800 Hz  $\pm$ 100 Hz. Select the wideband mode (800 MHz only) and deviation should be 1000 Hz  $\pm$ 100 Hz.
3. Reselect Group 1 and speak into the microphone. Typical deviation should be 1.2 kHz  $\pm$ 100 Hz in the narrowband mode and 3.0 kHz  $\pm$ 100 Hz in the wideband mode.
4. Also check deviation on middle and high channels.

## SECTION 8 PARTS LIST

Ref No	Description	Part No.	Ref No	Description	Part No.
<b>FRONT PANEL ASSEMBLY AND MECHANICAL PARTS</b>			DS 002	1-digit LED display (low tier)	549-4002-019
				LED green smd (high tier)	549-4001-145
A 101	Plastic front panel assembly (low tier)	587-9840-101	DS 003	LED green smd	549-4001-145
A 400	Display PC board assembly, complete board (high tier)	585-3000-340	DS 004	LED green smd	549-4001-145
A 475	Display wire harness (all tiers)	023-9800-475	DS 005	LED green smd	549-4001-145
A 700	Plastic front panel assembly (high tier)	See MP700	EP 010	Ferrite noise suppressor (J201/ J302)	515-9034-065
C 001	1.0 $\mu$ F 10V tantalum smd	510-2624-109	HW 001	Screw, 4-40 x 1/4" flt hd (rem hd)	575-8204-008
C 002	0.1 $\mu$ F X7R $\pm$ 10% 50V smd (low tier)	510-3606-104		Nut, RF hex .375 x 24	560-9060-010
	1.0 $\mu$ F 10V tantalum smd (high tier)	510-2624-109	HW002	Screw, #2-56 x 3/4 ss phil ph	575-9902-024
C 003	0.1 $\mu$ F X7R $\pm$ 10% 50V smd (low tier)	510-3606-104	HW003	Screw, 6-32 pan Torx	575-0006-008
	1.0 $\mu$ F 10V tantalum smd (high tier)	510-2624-109	HW004	Screw, No. 4 x 3/16" flt hd zps	575-1204-006
C 004	0.1 $\mu$ F X7R $\pm$ 10% 50V smd (low tier)	510-3606-104	HW005	Screw, 4-40 x 5/16" pan hd zps	575-1604-010
	.01 $\mu$ F X7R $\pm$ 10% 50V smd (high tier)	510-3605-103		Screw, 4-40 x 1/4" pan hd (UHF)	575-1604-008
C 005	.22 $\mu$ F X7R $\pm$ 10% 50V smd (low tier)	510-3606-224	HW006	Insert, 2-56 RF brd	537-2501-031
	10 pF $\pm$ 5% NPO 50V smd (high tier)	510-3615-100	HW007	Lockwasher, No. 2	596-2102-006
C 006	.0068 $\mu$ F X7R $\pm$ 10% 50V (low tier)	510-3605-682	HW008	Washer, split lock No. #4	596-1304-008
	0.1 $\mu$ F X7R $\pm$ 10% 50V smd (high tier)	510-3606-104	HW009	Screw, 6-32 x .1875 rd hd Torx	575-9406-406
C 007	24 pF $\pm$ 5% NPO 50V cer smd	510-3615-240	HW 010	Screw, 4-40 x 1/8 pan hd zps (spkr)	575-1604-004
C 008	.01 $\mu$ F X7R $\pm$ 10% 50V cer smd	510-3605-103		Screw, 4-40 x 1/4" pan hd (low tier)	575-0604-008
CR 001	Green LED	549-4001-203	HW 011	No. 4 washer	596-1104-008
CR 002	Yellow LED	549-4001-202		Screw, 6-32 x 5/16" pan hd Torx	575-0006-010
CR 003	Red LED	549-4001-201	HW 012	No. 4 swage spacer	574-5100-116
CR 004	Switching diode (low tier)	523-1504-002		Screw, 4-40 x 1/4" pan hd	575-0604-008
	LED, dual color, red/grn (included in A400), high tier	549-4001-215	HW 701	Washer, .438 x .274 x .030	596-9410-010
DS 001	7-segment display, .3" (low tier)	549-4002-020	HW 702	Screw, 4-20 x 1/4" (low tier)	575-5604-008
	LED green (high tier)	549-4001-145		Spanner nut, 3/8 x 7mm (high tier)	013-1313-018
			HW 703	Screw, 2-28 x 1/4" ph phil cps	575-5602-008
			J 001	Connector housing, 2-pin (speaker jk)	515-9031-281
				Connector, 12-pin (low/high tier display boards)	515-7111-287
				Connector, 12-pin (display har- ness)	515-7100-928
				Modular jack, 8-pin spec (mic jack)	515-2006-040
			J 002	Connector, 12-pin (interface bd)	515-7100-946
				Connector, 12-pin (display har- ness)	515-7100-928
			J 003	Connector, 20-pin (interface bd)	515-7100-945

## FRONT PANEL ASSEMBLY AND MECHANICAL PARTS (CONT'D)

Ref No	Description	Part No.	Ref No	Description	Part No.
J 701	Connector housing, 2-pin (speaker jk)	515-9031-281	MP 705	Block, acoustic (high tier)	574-3002-141
LS 001	Speaker, 3 x 2 8-ohm (high tier)	589-1015-003		Speaker bracket (low tier)	017-2224-126
LS 701	Speaker, 3 x 2 8-ohm (low tier)	589-1015-003	MP 706	Speaker gasket (low tier)	018-1136-126
MP 001	Chassis, metal (800/900 MHz)	015-0980-002	MP 900	Can-VCO	017-2225-752
	Chassis, metal (UHF)	015-0980-004	P 001	Connector, 2-pin right angle (high tier speaker harness)	515-7100-602
	Display cover (remote head)	017-2227-051	PC 400	PC board, display, incld in A400) (high tier)	035-9800-400
MP 002	Speaker box/bracket	017-2226-024	PC 450	PC board, interface (high tier)	035-9800-450
	1/4 in. coil shield	578-0003-001	Q 001	NPN general purpose	576-0003-658
	Cable housing (remote head)	017-2227-053	Q 002	NPN general purpose	576-0003-658
MP 003	TO-220 clip	017-2226-022	Q 003	NPN general purpose	576-0003-658
	Speaker plate (remote head)	017-2227-055	Q 004	NPN general purpose	576-0003-658
MP 004	Foam mounting pad	018-1134-105	Q 005	NPN general purpose	576-0003-658
MP 005	Mounting bracket, 98xx	017-2229-005	Q 006	NPN general purpose	576-0003-658
MP 006	Acoustic insert	574-3002-140	Q 007	NPN general purpose	576-0003-658
MP 007	Low pass filter shield	017-2229-003	Q 100	NPN UHF low noise	576-0003-651
	Foam mounting pad (remote head)	018-1134-105	R 001	47k ohm $\pm 5\%$ 1/8W smd (low tier)	569-0105-473
MP 008	RF shield, PA cavity (except following)	017-2229-012		Pot 50k ohm w/push-on sw (high tier)	562-0018-075
	RF shield, PA cavity (430-470 MHz, low power only)	017-2229-013	R 002	47k ohm $\pm 5\%$ 1/8W smd (low tier)	569-0105-473
MP 010	Cover, top	017-2227-001		22 ohm $\pm 10\%$ 2W wire-wound (high tier)	569-2004-220
MP 011	Cover, bottom	017-2227-003	R 003	47k ohm $\pm 5\%$ 1/8W smd	569-0105-473
MP 012	Insulator (under RF bd)	018-1132-018	R 004	47k ohm $\pm 5\%$ 1/8W smd	569-0105-473
MP 013	Alum clad foam shield (on cover)	574-3001-035	R 005	47k ohm $\pm 5\%$ 1/8W smd	569-0105-473
MP 014	Alum clad foam pad	574-3001-036	R 006	47k ohm $\pm 5\%$ 1/8W smd	569-0105-473
MP 015	Foam, RF cavity	574-3001-037	R 007	47k ohm $\pm 5\%$ 1/8W smd	569-0105-473
MP 016	RF cavity shield	017-2227-007	R 008	47k ohm $\pm 5\%$ 1/8W smd	569-0105-473
MP 020	Grafoil, .650	018-1007-108	R 009	47k ohm $\pm 5\%$ 1/8W smd	569-0105-473
MP 107	Rubber keypad (low tier)	032-0793-107	R 010	10k ohm $\pm 5\%$ 1/8W smd	569-0105-103
MP 509	Heat sink sleeving (Q509)	016-2229-001	R 011	200 ohm $\pm 5\%$ 1/8W smd (low tier)	569-0105-201
MP 600	Jumper strap	017-2224-340		10k ohm $\pm 5\%$ 1/8W smd (high tier)	569-0105-103
MP 700	Front panel assembly		R 012	200 ohm $\pm 5\%$ 1/8W smd (low tier)	569-0105-201
	Standard plastic for high tier	587-9840-005		10k ohm $\pm 5\%$ 1/8W smd (high tier)	569-0105-103
	Data models	017-2227-010	R 013	200 ohm $\pm 5\%$ 1/8W smd (low tier)	569-0105-201
	Remote mount models	017-2227-059		10k ohm $\pm 5\%$ 1/8W smd (high tier)	569-0105-103
MP 701	Elastomeric key pad (high tier)	032-0793-007	R 014	200 ohm $\pm 5\%$ 1/8W smd (low tier)	569-0105-201
MP 702	Key cap set, LTR (5 caps)	587-9840-001		10k ohm $\pm 5\%$ 1/8W smd (high tier)	569-0105-103
	Key cap set, optional (25 caps)	587-9840-004			
MP 703	Control knob	032-0792-010			
MP 704	Membrane speaker (high tier)	018-1136-124			
	Foam pad, over spkr wires (low tier)	018-1134-135			



## UHF RF AND PA BOARDS

Ref No	Description	Part No.
R 015	200 ohm $\pm 5\%$ 1/8W smd (low tier)	569-0105-201
	10k ohm $\pm 5\%$ 1/8W smd (high tier)	569-0105-103
R 016	200 ohm $\pm 5\%$ 1/8W smd (low tier)	569-0105-201
	10k ohm $\pm 5\%$ 1/8W smd (high tier)	569-0105-103
R 017	200 ohm $\pm 5\%$ 1/8W smd (low tier)	569-0105-201
	10k ohm $\pm 5\%$ 1/8W smd (high tier)	569-0105-103
R 018	200 ohm $\pm 5\%$ 1/8W smd (low tier)	569-0105-201
	10k ohm $\pm 5\%$ 1/8W smd (high tier)	569-0105-103
R 020	10k ohm $\pm 5\%$ 1/8W smd	569-0105-103
R 021	10k ohm $\pm 5\%$ 1/8W smd	569-0105-103
R 023	4.7k ohm $\pm 5\%$ 1/8W smd	569-0105-472
R 024	4.7k ohm $\pm 5\%$ 1/8W smd	569-0105-472
R 025	4.7k ohm $\pm 5\%$ 1/8W smd	569-0105-472
R 026	4.7k ohm $\pm 5\%$ 1/8W smd	569-0105-472
R 027	4.7k ohm $\pm 5\%$ 1/8W smd	569-0105-472
R 029	1.0k ohm $\pm 5\%$ 1/8W smd	569-0105-102
R 030	1.0k ohm $\pm 5\%$ 1/8W smd	569-0105-102
R 031	1.0k ohm $\pm 5\%$ 1/8W smd	569-0105-102
R 032	1.0k ohm $\pm 5\%$ 1/8W smd	569-0105-102
R 033	180 ohm $\pm 5\%$ 1/8W smd	569-0115-181
R 034	180 ohm $\pm 5\%$ 1/8W smd	569-0115-181
R 035	68 ohm $\pm 5\%$ 1/8W smd	569-0115-680
R 036	68 ohm $\pm 5\%$ 1/8W smd	569-0115-680
R 037	22 ohm $\pm 5\%$ 1/8W smd	569-0115-220
R 038	22 ohm $\pm 5\%$ 1/8W smd	569-0115-220
R 039	22 ohm $\pm 5\%$ 1/8W smd	569-0115-220
R 040	22 ohm $\pm 5\%$ 1/8W smd	569-0115-220
R 041	10k ohm $\pm 5\%$ 1/8W smd	569-0105-103
R 042	10k ohm $\pm 5\%$ 1/8W smd	569-0105-103
R 043	Thermistor, 10k ohm $\pm 5\%$	569-3013-007
R 044	95.3k ohm $\pm 1\%$ 1/8W smd	569-0111-495
R 046	4.7k ohm trimmer smd	562-0138-472
R 047	8.06k ohm $\pm 1\%$ 1/8W smd	569-0111-388
R 048	1.0k ohm $\pm 5\%$ 1/8W smd	569-0105-102
R 049	1.0k ohm $\pm 5\%$ 1/8W smd	569-0105-102
R 050	10k ohm $\pm 5\%$ 1/8W smd	569-0105-103
S 001	Switch, rotary and push	583-2042-001
U 001	8-bit priority encoder 4532 (low tier)	544-3016-532

Ref No	Description	Part No.
	LCD controller HD66710 (high tier)	544-2027-014
U 002	7-seg. LED dsply drvr 4499 (low tier)	544-3016-499
	Microcontroller, 68HC705P9 (high tier)	023-9998-401
U 003	8-bit shift register 74HC165 (low tier)	544-3766-165
	Regulator, 5V 1/2A 78M05 (high tier)	544-2003-079
U 004	Scmitt trigger/invtrr TC7S14	544-3123-014
W 001	Rem pigtail cable, control unit 5 ft	597-9800-007
	Data/accessory pigtail cable, 1 ft	597-9800-001
	Data only pigtail cable, 1 ft	597-9800-005
W 003	Rem pigtail cable, transceiver 1 ft	597-9800-011

Ref No.	Description	Part No.
<b>UHF RF AND PA BOARDS</b>		
A 533	Q600 Stabilizer Bd Assembly, 430-470 MHz, 40W only, includes: .01 $\mu$ F X7R $\pm 10\%$ 50V cer smd 33 ohm 1W resistor 33 ohm resistor	023-9800-531 510-3606-103 569-0175-330
A 900	VCO module (430-470 MHz)	023-9840-931
	VCO module (470-512 MHz)	023-9840-951
C 201	33 pF $\pm 5\%$ NPO 50V cer smd (430-470 MHz)	510-3615-330
	27 pF $\pm 5\%$ NPO 50V cer smd (470-512 MHz)	510-3615-270
C 202	100 pF NPO $\pm 5\%$ 50V cer smd	510-3601-101
C 203	5.6 pF $\pm 5\%$ NPO 50V cer smd (430-470 MHz)	510-3615-569
	3.6 pF $\pm 5\%$ NPO 50V cer smd (470-512 MHz)	510-3615-369
C 204	6.8 pF NPO $\pm 5\%$ 50V cer smd (430-470 MHz)	510-3601-689
	5.1 pF NPO $\pm 5\%$ 50V cer smd (470-512 MHz)	510-3615-519
C 205	47 pF NPO $\pm 5\%$ 50V cer smd	510-3601-470

## UHF RF AND PA BOARDS (CONT'D)

Ref No.	Description	Part No.
C 206	(430-470 MHz) 39 pF $\pm 5\%$ NPO 50V cer smd	510-3615-390
	(470-512 MHz) 2.7 pF $\pm 5\%$ NPO 50V cer smd	510-3615-279
	(430-470 MHz) 3.3 pF $\pm 5\%$ NPO 50V cer smd	510-3615-339
C 207	(470-512 MHz) 1.8 pF $\pm 5\%$ NPO 50V cer smd	510-3601-189
	(430-470 MHz) 1.5 pF $\pm 5\%$ NPO 50V cer smd	510-3615-159
C 208	(470-512 MHz) 3.3 pF NPO $\pm 5\%$ 50V cer smd	510-3601-339
	(430-470 MHz) 2.4 pF $\pm 5\%$ NPO 50V cer smd	510-3615-249
C 209	100 pF NPO $\pm 5\%$ 50V cer smd	510-3601-101
C 210	100 pF NPO $\pm 5\%$ 50V cer smd	510-3601-101
C 211	6.8 pF NPO $\pm 5\%$ 50V cer smd	510-3601-689
	(430-470 MHz) 3.6 pF $\pm 5\%$ NPO 50V cer smd	510-3615-369
C 212	(470-512 MHz) 2.2 pF $\pm 5\%$ NPO 50V cer smd	510-3601-229
	(430-470 MHz) 1.6 pF $\pm 5\%$ NPO 50V cer smd	510-3615-169
C 213	(470-512 MHz) 47 pF $\pm 5\%$ NPO 50V cer smd	510-3601-470
	(430-470 MHz) 39 pF $\pm 5\%$ NPO 50V cer smd	510-3615-390
C 214	(470-512 MHz) 6.8 pF NPO $\pm 5\%$ 50V cer smd	510-3601-689
	(430-470 MHz) 5.1 pF $\pm 5\%$ NPO 50V cer smd	510-3615-519
C 215	(470-512 MHz) 5.6 pF $\pm 5\%$ NPO 50V cer smd	510-3615-569
	(430-470 MHz) 3.6 pF $\pm 5\%$ NPO 50V cer smd	510-3615-369
C 216	(470-512 MHz) 6.8 pF NPO $\pm 5\%$ 50V cer smd	510-3601-689
	(430-470 MHz) 4.3 pF $\pm 5\%$ NPO 50V cer smd	510-3615-439
C 217	(470-512 MHz) 2.7 pF $\pm 5\%$ NPO 50V cer smd	510-3615-279

Ref No.	Description	Part No.
C 218	3.3 pF $\pm 5\%$ NPO 50V cer smd	510-3615-339
	(470-512 MHz) 3.3 pF NPO $\pm 5\%$ 50V cer smd	510-3601-339
C 219	(430-470 MHz) 2.4 pF $\pm 5\%$ NPO 50V cer smd	510-3615-249
	(470-512 MHz) 1.8 pF $\pm 5\%$ NPO 50V cer smd	510-3601-189
C 220	(430-470 MHz) 1.5 pF $\pm 5\%$ NPO 50V cer smd	510-3615-159
	(470-512 MHz) 100 pF NPO $\pm 5\%$ 50V cer smd	510-3601-101
C 221	6.8 pF NPO $\pm 5\%$ 50V cer smd	510-3601-689
C 222	.01 $\mu$ F X7R $\pm 10\%$ 50V cer smd	510-3605-103
C 223	.01 $\mu$ F X7R $\pm 10\%$ 50V cer smd	510-3605-103
C 224	100 pF NPO $\pm 5\%$ 50V cer smd	510-3601-101
C 225	.01 $\mu$ F X7R $\pm 10\%$ 50V cer smd	510-3605-103
C 226	100 pF NPO $\pm 5\%$ 50V cer smd	510-3601-101
C 227	22 pF $\pm 5\%$ NPO 50V cer smd	510-3615-220
	(430-470 MHz) 10 pF $\pm 5\%$ NPO 50V cer smd	510-3615-100
C 228	(470-512 MHz) 8.2 pF $\pm 5\%$ NPO 50V cer smd	510-3615-829
	(430-470 MHz) 4.7 pF $\pm 5\%$ NPO 50V cer smd	510-3615-479
C 229	100 pF NPO $\pm 5\%$ 50V cer smd	510-3601-101
C 230	100 pF NPO $\pm 5\%$ 50V cer smd	510-3601-101
C 231	3.0 pF $\pm 5\%$ NPO 50V cer smd	510-3601-309
	(430-470 MHz) 2.4 pF $\pm 5\%$ NPO 50V cer smd	510-3615-249
C 232	(470-512 MHz) 3.3 pF NPO $\pm 5\%$ 50V cer smd	510-3601-339
	(430-470 MHz) 2.4 pF $\pm 5\%$ NPO 50V cer smd	510-3615-249
C 233	(470-512 MHz) 1.8 pF $\pm 5\%$ NPO 50V cer smd	510-3601-189
	(430-470 MHz) 1.6 pF $\pm 5\%$ NPO 50V cer smd	510-3615-169
C 234	(470-512 MHz) 4.3 pF $\pm 5\%$ NPO 50V cer smd	510-3601-439
	(430-470 MHz) 3.3 pF $\pm 5\%$ NPO 50V cer smd	510-3615-339
C 235	(470-512 MHz) 6.8 pF NPO $\pm 5\%$ 50V cer smd	510-3601-689

## UHF RF AND PA BOARDS (CONT'D)

Ref No.	Description	Part No.
C 236	5.6 pF $\pm 5\%$ NPO 50V cer smd (470-512 MHz)	510-3615-569
	22 pF $\pm 5\%$ NPO 50V cer smd (430-470 MHz)	510-3615-220
C 237	18 pF $\pm 5\%$ NPO 50V cer smd (470-512 MHz)	510-3615-180
	10 pF $\pm 5\%$ NPO 50V cer smd (430-470 MHz)	510-3615-100
C 238	7.5 pF $\pm 5\%$ NPO 50V cer smd (470-512 MHz)	510-3615-759
	3.3 pF NPO $\pm 5\%$ 50V cer smd	510-3601-339
C 239	1.8 pF $\pm 5\%$ NPO 50V cer smd (430-470 MHz)	510-3601-189
C 240	1.5 pF $\pm 5\%$ NPO 50V cer smd (470-512 MHz)	510-3615-159
	3.3 pF NPO $\pm 5\%$ 50V cer smd (430-470 MHz)	510-3601-339
	2.7 pF $\pm 5\%$ NPO 50V cer smd (470-512 MHz)	510-3615-279
C 241	22 pF $\pm 5\%$ NPO 50V cer smd (430-470 MHz)	510-3615-220
	18 pF $\pm 5\%$ NPO 50V cer smd (470-512 MHz)	510-3615-180
C 242	6.8 pF NPO $\pm 5\%$ 50V cer smd (430-470 MHz)	510-3601-689
	5.6 pF $\pm 5\%$ NPO 50V cer smd (470-512 MHz)	510-3615-569
C 243	4.3 pF $\pm 5\%$ NPO 50V cer smd (430-470 MHz)	510-3601-439
	3.3 pF $\pm 5\%$ NPO 50V cer smd (470-512 MHz)	510-3615-339
C 244	10 pF $\pm 5\%$ NPO 50V cer smd (430-470 MHz)	510-3615-100
	6.8 pF $\pm 5\%$ NPO 50V cer smd (470-512 MHz)	510-3615-689
C 245	8.2 pF $\pm 5\%$ NPO 50V cer smd (430-470 MHz)	510-3615-829
	5.6 pF $\pm 5\%$ NPO 50V cer smd (470-512 MHz)	510-3615-569
C 246	3.9 pF NPO $\pm 5\%$ 50V cer smd	510-3601-399
C 247	.01 $\mu$ F X7R $\pm 10\%$ 50V cer smd	510-3605-103
C 248	.01 $\mu$ F X7R $\pm 10\%$ 50V cer smd	510-3605-103
C 249	.01 $\mu$ F X7R $\pm 10\%$ 50V cer smd	510-3605-103
C 251	18 pF NPO $\pm 5\%$ 50V cer smd	510-3601-180
C 252	150 pF NPO $\pm 5\%$ 50V cer smd	510-3601-151

Ref No.	Description	Part No.
C 253	.01 $\mu$ F X7R $\pm 10\%$ 50V cer smd	510-3605-103
C 255	100 pF NPO $\pm 5\%$ 50V cer smd	510-3601-101
C 256	6.8 pF NPO $\pm 5\%$ 50V cer smd	510-3601-689
C 258	.01 $\mu$ F X7R $\pm 10\%$ 50V cer smd	510-3605-103
C 259	100 pF NPO $\pm 5\%$ 50V cer smd	510-3601-101
C 260	9.1 pF $\pm 5\%$ NPO 50V cer smd (430-470 MHz)	510-3601-919
	8.2 pF $\pm 5\%$ NPO 50V cer smd (470-512 MHz)	510-3615-829
C 261	9.1 pF $\pm 5\%$ NPO 50V cer smd (430-470 MHz)	510-3601-919
	6.8 pF $\pm 5\%$ NPO 50V cer smd (470-512 MHz)	510-3615-689
C 262	3.3 pF NPO $\pm 5\%$ 50V cer smd	510-3601-339
C 263	2.7 pF $\pm 5\%$ NPO 50V cer smd (430-470 MHz)	510-3615-279
	2.4 pF $\pm 5\%$ NPO 50V cer smd (470-512 MHz)	510-3615-249
C 264	7.5 pF $\pm 5\%$ NPO 50V cer smd	510-3601-759
C 266	27 pF NPO $\pm 5\%$ 50V cer smd	510-3601-270
C 268	150 pF NPO $\pm 5\%$ 50V cer smd	510-3601-151
C 269	5.6 pF $\pm 5\%$ NPO 50V cer smd	510-3615-569
C 270	22 pF $\pm 5\%$ NPO 50V cer smd	510-3615-220
C 271	27 pF NPO $\pm 5\%$ 50V cer smd	510-3601-270
C 272	.01 $\mu$ F X7R $\pm 10\%$ 50V cer smd	510-3605-103
C 274	.001 $\mu$ F X7R $\pm 10\%$ 50V cer smd	510-3605-102
C 275	.01 $\mu$ F X7R $\pm 10\%$ 50V cer smd	510-3605-103
C 276	.01 $\mu$ F X7R $\pm 10\%$ 50V cer smd	510-3605-103
C 277	.01 $\mu$ F X7R $\pm 10\%$ 50V cer smd	510-3605-103
C 278	.01 $\mu$ F X7R $\pm 10\%$ 50V cer smd	510-3605-103
C 281	.01 $\mu$ F X7R $\pm 10\%$ 50V cer smd	510-3605-103
C 282	.01 $\mu$ F X7R $\pm 10\%$ 50V cer smd	510-3605-103
C 283	.01 $\mu$ F X7R $\pm 10\%$ 50V cer smd	510-3605-103
C 284	.01 $\mu$ F X7R $\pm 10\%$ 50V cer smd	510-3605-103
C 285	.01 $\mu$ F X7R $\pm 10\%$ 50V cer smd	510-3605-103
C 286	.01 $\mu$ F X7R $\pm 10\%$ 50V cer smd	510-3605-103
C 287	47 pF NPO $\pm 5\%$ 50V cer smd	510-3601-470
C 288	7.5 pF $\pm 5\%$ NPO 50V cer smd	510-3601-759
C 289	.01 $\mu$ F X7R $\pm 10\%$ 50V cer smd	510-3605-103
C 290	36 pF NPO $\pm 5\%$ 50V cer smd	510-3601-360
C 291	.01 $\mu$ F X7R $\pm 10\%$ 50V cer smd	510-3605-103
C 292	.01 $\mu$ F X7R $\pm 10\%$ 50V cer smd	510-3605-103
C 293	.01 $\mu$ F X7R $\pm 10\%$ 50V cer smd	510-3605-103
C 294	47 $\mu$ F 10V tantalum smd	510-2624-470
C 295	.1 $\mu$ F X7R $\pm 10\%$ 50V cer smd	510-3606-104

## UHF RF AND PA BOARDS (CONT'D)

Ref No.	Description	Part No.
C 296	.01 $\mu$ F X7R $\pm$ 10% 50V cer smd	510-3605-103
C 297	.01 $\mu$ F X7R $\pm$ 10% 50V cer smd	510-3605-103
C 298	.01 $\mu$ F X7R $\pm$ 10% 50V cer smd	510-3605-103
C 299	.01 $\mu$ F X7R $\pm$ 10% 50V cer smd	510-3605-103
C 300	.01 $\mu$ F X7R $\pm$ 10% 50V cer smd	510-3605-103
C 301	10 pF $\pm$ 5% NPO 50V cer smd	510-3602-100
C 302	.01 $\mu$ F X7R $\pm$ 10% 50V cer smd	510-3605-103
C 303	.33 $\mu$ F X7R $\pm$ 10% 16V cer smd	510-3631-334
C 304	.01 $\mu$ F X7R $\pm$ 10% 50V cer smd	510-3605-103
C 305	100 pF NPO $\pm$ 5% 50V cer smd	510-3601-101
C 306	100 pF NPO $\pm$ 5% 50V cer smd	510-3601-101
C 307	3.9 pF NPO $\pm$ 5% 50V cer smd (430-470 MHz)	510-3601-399
	4.3 pF $\pm$ 5% NPO 50V cer smd (470-512 MHz)	510-3615-439
C 500	100 pF NPO $\pm$ 5% 50V cer smd (unrevised 430-470 MHz)	510-3601-101
	.1 $\mu$ F X7R $\pm$ 10% 50V cer smd (all others)	510-3606-104
C 501	.1 $\mu$ F X7R $\pm$ 10% 50V cer smd (unrevised 430-470 MHz)	510-3606-104
	100 pF NPO $\pm$ 5% 50V cer smd (all others)	510-3601-101
C 502	.01 $\mu$ F X7R $\pm$ 10% 50V cer smd (unrevised 430-470 MHz)	510-3605-103
	100 pF NPO $\pm$ 5% 50V cer smd (all others)	510-3601-101
C 503	100 pF NPO $\pm$ 5% 50V cer smd (unrevised 430-470 MHz)	510-3601-101
	.01 $\mu$ F X7R $\pm$ 10% 50V cer smd (all others)	510-3605-103
C 504	.1 $\mu$ F X7R $\pm$ 10% 50V cer smd	510-3606-104
C 505	.01 $\mu$ F X7R $\pm$ 10% 50V cer smd	510-3605-103
C 506	100 pF NPO $\pm$ 5% 50V cer smd	510-3601-101
C 507	100 pF NPO $\pm$ 5% 50V cer smd	510-3601-101
C 508	100 pF NPO $\pm$ 5% 50V cer smd	510-3601-101
C 509	100 pF NPO $\pm$ 5% 50V cer smd	510-3601-101
C 510	100 pF NPO $\pm$ 5% 50V cer smd	510-3601-101
C 511	100 pF NPO $\pm$ 5% 50V cer smd (unrevised 430-470 MHz)	510-3601-101
	6.8 $\mu$ F 35V tantalum smd (all others)	510-2635-689
C 512	10 $\mu$ F 25V tantalum smd (unrevised 430-470 MHz)	510-2627-100

Ref No.	Description	Part No.
	100 pF NPO $\pm$ 5% 50V cer smd (all others)	510-3601-101
C 513	.1 $\mu$ F X7R $\pm$ 10% 50V cer smd (unrevised 430-470 MHz)	510-3606-104
	100 pF NPO $\pm$ 5% 50V cer smd (all others)	510-3601-101
C 514	.1 $\mu$ F X7R $\pm$ 10% 50V cer smd (unrevised 430-470 MHz)	510-3606-104
	10 $\mu$ F 25V tantalum smd (all others)	510-2627-100
C 515	100 pF NPO $\pm$ 5% 50V cer smd (unrevised 430-470 MHz)	510-3601-101
	.1 $\mu$ F X7R $\pm$ 10% 50V cer smd (all others)	510-3606-104
C 516	.01 $\mu$ F X7R $\pm$ 10% 50V cer smd (unrevised 430-470 MHz)	510-3605-103
	100 pF NPO $\pm$ 5% 50V cer smd (all others)	510-3601-101
C 517	10 $\mu$ F 25V tantalum smd (unrevised 430-470 MHz)	510-2627-100
	.01 $\mu$ F X7R $\pm$ 10% 50V cer smd (all others)	510-3605-103
C 518	100 pF NPO $\pm$ 5% 50V cer smd	510-3601-101
C 519	.01 $\mu$ F X7R $\pm$ 10% 50V cer smd	510-3605-103
C 520	100 pF NPO $\pm$ 5% 50V cer smd	510-3601-101
C 521	100 pF NPO $\pm$ 5% 50V cer smd	510-3601-101
C 522	.01 $\mu$ F X7R $\pm$ 10% 50V cer smd	510-3605-103
C 523	100 pF NPO $\pm$ 5% 50V cer smd (unrevised 430-470 MHz)	510-3601-101
	.01 $\mu$ F X7R $\pm$ 10% 50V cer smd (all others)	510-3605-103
C 524	220 pF $\pm$ 5% NPO 50V cer smd (unrevised 430-470 MHz)	510-3615-221
	100 pF NPO $\pm$ 5% 50V cer smd (all others)	510-3601-101
C 525	100 pF NPO $\pm$ 5% 50V cer smd (unrevised 430-470 MHz)	510-3601-101
	.01 $\mu$ F X7R $\pm$ 10% 50V cer smd (all others)	510-3605-103
C 526	.01 $\mu$ F X7R $\pm$ 10% 50V cer smd	510-3605-103
C 527	100 pF NPO $\pm$ 5% 50V cer smd	510-3601-101
C 528	.01 $\mu$ F X7R $\pm$ 10% 50V cer smd (unrevised 430-470 MHz)	510-3605-103
	100 pF NPO $\pm$ 5% 50V cer smd (all others)	510-3601-101

## UHF RF AND PA BOARDS (CONT'D)

Ref No.	Description	Part No.
C 529	12 pF NPO $\pm 5\%$ cer smd (unrevised 430-470 MHz)	510-3601-120
	.01 $\mu$ F X7R $\pm 10\%$ 50V cer smd (all others)	510-3605-103
C 530	39 pF NPO $\pm 5\%$ 50V cer smd (unrevised 430-470 MHz)	510-3601-390
	.01 $\mu$ F X7R $\pm 10\%$ 50V cer smd (all others)	510-3605-103
C 531	5.6 pF $\pm 5\%$ NPO 50V cer smd (unrevised 430-470 MHz)	510-3615-569
	100 pF NPO $\pm 5\%$ 50V cer smd (all others)	510-3601-101
C 532	51 pF $\pm 5\%$ NPO 50V cer smd (unrevised 430-470 MHz)	510-3601-510
	12 pF $\pm 5\%$ NPO 50V cer smd (revised 430-470 MHz)	510-3615-120
	10 pF $\pm 5\%$ NPO 50V cer smd (470-512 MHz)	510-3615-100
C 533	43 pF NPO $\pm 5\%$ 50V cer smd (unrevised 430-470 MHz)	510-3601-430
	12 pF $\pm 5\%$ NPO 50V cer smd (revised 430-470 MHz)	510-3615-120
	10 pF $\pm 5\%$ NPO 50V cer smd (470-512 MHz)	510-3615-100
C 534	56 pF $\pm 5\%$ NPO 50V cer smd (unrevised 430-470 MHz)	510-3615-560
C 535	12 pF 250V mini mica (revised 430-470 MHz)	510-0019-120
	11 pF 250V mini mica (470-512 MHz)	510-0019-110
C 536	100 pF NPO $\pm 5\%$ 50V cer smd (unrevised 430-470 MHz)	510-3601-101
	39 pF 250V mini mica (revised 430-470 MHz)	510-0019-390
	33 pF 250V mini mica (470-512 MHz)	510-0019-330
C 537	10 pF $\pm 5\%$ NPO 50V cer smd (unrevised 430-470 MHz)	510-3615-100
	100 pF $\pm 10\%$ 50V hi Q smd (all others)	510-3663-101
C 538	15 pF $\pm 5\%$ NPO 50V cer smd (unrevised 430-470 MHz)	510-3615-150
	12 pF $\pm 5\%$ NPO 50V cer smd (revised 430-470 MHz)	510-3615-120

Ref No.	Description	Part No.
	10 pF $\pm 5\%$ NPO 50V cer smd (470-512 MHz)	510-3615-100
C 539	6.8 pF NPO $\pm 5\%$ 50V cer smd (unrevised 430-470 MHz)	510-3601-689
	12 pF $\pm 5\%$ NPO 50V cer smd (revised 430-470 MHz)	510-3615-120
	10 pF $\pm 5\%$ NPO 50V cer smd (470-512 MHz)	510-3615-100
C 540	3.9 pF $\pm 5\%$ NPO 50V cer smd (unrevised 430-470 MHz)	510-3615-399
	100 pF NPO $\pm 5\%$ 50V cer smd (all others)	510-3601-101
C 541	24 pF $\pm 5\%$ NPO 50V cer smd (unrevised 430-470 MHz)	510-3602-240
	16 pF $\pm 5\%$ NPO 50V cer smd (revised 430-470 MHz)	510-3615-160
	15 pF $\pm 5\%$ NPO 50V cer smd (470-512 MHz)	510-3615-150
C 542	20 pF $\pm 5\%$ NPO 50V cer smd (unrevised 430-470 MHz)	510-3615-200
	10 pF $\pm 5\%$ NPO 50V cer smd (revised 430-470 MHz)	510-3615-100
	8.2 pF $\pm 5\%$ NPO 50V cer smd (470-512 MHz)	510-3615-829
C 543	22 pF $\pm 5\%$ NPO 50V cer smd (unrevised 430-470 MHz)	510-3615-220
	100 pF $\pm 5\%$ NPO 50V cer smd (all others)	510-3615-101
C 544	30 pF $\pm 5\%$ NPO 50V cer smd (unrevised 430-470 MHz)	510-3615-300
	100 pF $\pm 5\%$ NPO 50V cer smd (all others)	510-3615-101
C 545	24 pF $\pm 5\%$ NPO 50V cer smd (unrevised 430-470 MHz)	510-3602-240
	12 pF 250V mini mica (revised 430-470 MHz)	510-0019-120
	11 pF 250V mini mica (470-512 MHz)	510-0019-110
C 546	24 pF $\pm 5\%$ NPO 50V cer smd (unrevised 430-470 MHz)	510-3602-240
	12 pF $\pm 5\%$ NPO 50V cer smd (revised 430-470 MHz)	510-3615-120
	10 pF $\pm 5\%$ NPO 50V cer smd (470-512 MHz)	510-3615-100

## UHF RF AND PA BOARDS (CONT'D)

Ref No.	Description	Part No.
C 547	24 pF $\pm 5\%$ NPO 50V cer smd (unrevised 430-470 MHz)	510-3602-240
	12 pF $\pm 5\%$ NPO 50V cer smd (revised 430-470 MHz)	510-3615-120
	10 pF $\pm 5\%$ NPO 50V cer smd (470-512 MHz)	510-3615-100
C 548	10 $\mu$ F 25V tantalum smd (unrevised 430-470 MHz)	510-2627-100
	5.1 pF $\pm 5\%$ NPO 50V cer smd (revised 430-470 MHz)	510-3615-519
	4.7 pF $\pm 5\%$ NPO 50V cer smd (470-512 MHz)	510-3615-479
C 549	470 $\mu$ F 25V electrolytic (unrevised 430-470 MHz)	510-4064-471
	7.5 pF $\pm 5\%$ NPO 50V cer smd (revised 430-470 MHz)	510-3615-759
	6.8 pF $\pm 5\%$ NPO 50V cer smd (470-512 MHz)	510-3615-689
C 550	.01 $\mu$ F X7R $\pm 10\%$ 50V cer smd (unrevised 430-470 MHz)	510-3605-103
	13 pF $\pm 5\%$ NPO 50V cer smd (revised 430-470 MHz)	510-3615-130
	12 pF $\pm 5\%$ NPO 50V cer smd (470-512 MHz)	510-3615-120
C 551	100 pF NPO $\pm 5\%$ 50V cer smd (unrevised 430-470 MHz)	510-3601-101
	13 pF $\pm 5\%$ NPO 50V cer smd (revised 430-470 MHz)	510-3615-130
	12 pF $\pm 5\%$ NPO 50V cer smd (470-512 MHz)	510-3615-120
C 552	10 $\mu$ F 25V tantalum smd (unrevised 430-470 MHz)	510-2627-100
	13 pF $\pm 5\%$ NPO 50V cer smd (revised 430-470 MHz)	510-3615-130
	12 pF $\pm 5\%$ NPO 50V cer smd (470-512 MHz)	510-3615-120
C 553	470 $\mu$ F 25V electrolytic (unrevised 430-470 MHz)	510-4064-471
C 554	100 pF NPO $\pm 5\%$ 50V cer smd (unrevised 430-470 MHz)	510-3601-101
	43 pF 250V mini mica (revised 430-470 MHz)	510-0019-430
	33 pF 250V mini mica (470-512 MHz)	510-0019-330

Ref No.	Description	Part No.
C 555	100 pF NPO $\pm 5\%$ 50V cer smd (unrevised 430-470 MHz)	510-3601-101
	5.1 pF $\pm 5\%$ NPO 50V cer smd (revised 430-470 MHz)	510-3615-519
	4.7 pF $\pm 5\%$ NPO 50V cer smd (470-512 MHz)	510-3615-479
C 556	4.7 $\mu$ F 10V tantalum smd (unrevised 430-470 MHz)	510-2624-479
	5.1 pF $\pm 5\%$ NPO 50V cer smd (revised 430-470 MHz)	510-3615-519
	4.7 pF $\pm 5\%$ NPO 50V cer smd (470-512 MHz)	510-3615-479
C 557	.01 $\mu$ F X7R $\pm 10\%$ 50V cer smd (unrevised 430-470 MHz)	510-3605-103
	2.0 pF $\pm 5\%$ NPO 50V cer smd (revised 430-470 MHz)	510-3615-209
	1.0 pF $\pm 5\%$ NPO 50V cer smd (470-512 MHz)	510-3615-109
C 558	100 pF NPO $\pm 5\%$ 50V cer smd (unrevised 430-470 MHz)	510-3601-101
	10 pF $\pm 5\%$ NPO 50V cer smd (all others)	510-3615-100
C 559	100 pF NPO $\pm 5\%$ 50V cer smd (unrevised 430-470 MHz)	510-3601-101
	12 pF $\pm 5\%$ NPO 50V cer smd (revised 430-470 MHz)	510-3615-120
	10 pF $\pm 5\%$ NPO 50V cer smd (470-512 MHz)	510-3615-100
C 560	100 pF NPO $\pm 5\%$ 50V cer smd (unrevised 430-470 MHz)	510-3601-101
	10 $\mu$ F 25V tantalum smd (all others)	510-2627-100
C 561	4.7 $\mu$ F 10V tantalum smd (unrevised 430-470 MHz)	510-2624-479
	470 $\mu$ F 25V electrolytic (all others)	510-4064-471
C 562	100 pF NPO $\pm 5\%$ 50V cer smd (unrevised 430-470 MHz)	510-3601-101
	.01 $\mu$ F X7R $\pm 10\%$ 50V cer smd (all others)	510-3605-103
C 563	.01 $\mu$ F X7R $\pm 10\%$ 50V cer smd (unrevised 430-470 MHz)	510-3605-103
	100 pF NPO $\pm 5\%$ 50V cer smd (all others)	510-3601-101

## UHF RF AND PA BOARDS (CONT'D)

Ref No.	Description	Part No.
C 564	100 pF NPO $\pm 5\%$ 50V cer smd (unrevised 430-470 MHz)	510-3601-101
	10 $\mu$ F 25V tantalum smd (all others)	510-2627-100
C 565	10 $\mu$ F 25V tantalum smd (unrevised 430-470 MHz)	510-2627-100
	470 $\mu$ F 25V electrolytic (all others)	510-4064-471
C 566	.01 $\mu$ F X7R $\pm 10\%$ 50V cer smd (unrevised 430-470 MHz)	510-3605-103
	100 pF NPO $\pm 5\%$ 50V cer smd (all others)	510-3601-101
C 567	33 pF $\pm 5\%$ NPO 50V cer smd (unrevised 430-470 MHz)	510-3615-330
	100 pF NPO $\pm 5\%$ 50V cer smd (all others)	510-3601-101
C 568	15 pF $\pm 5\%$ NPO 50V cer smd (unrevised 430-470 MHz)	510-3602-150
	4.7 $\mu$ F 10V tantalum smd (all others)	510-2624-479
C 569	15 pF $\pm 5\%$ NPO 50V cer smd (unrevised 430-470 MHz)	510-3602-150
	.01 $\mu$ F X7R $\pm 10\%$ 50V cer smd (all others)	510-3605-103
C 570	2.7 pF $\pm 5\%$ NPO 50V cer smd (unrevised 430-470 MHz)	510-3615-279
	100 pF NPO $\pm 5\%$ 50V cer smd (all others)	510-3601-101
C 571	1.5 pF $\pm 5\%$ NPO 50V cer smd (unrevised 430-470 MHz)	510-3601-159
	100 pF NPO $\pm 5\%$ 50V cer smd (all others)	510-3601-101
C 572	20 pF $\pm 5\%$ NPO 50V cer smd (unrevised 430-470 MHz)	510-3615-200
	100 pF NPO $\pm 5\%$ 50V cer smd (all others)	510-3601-101
C 573	24 pF $\pm 5\%$ NPO 50V cer smd (unrevised 430-470 MHz)	510-3615-240
	4.7 $\mu$ F 10V tantalum smd (all others)	510-2624-479
C 574	22 pF $\pm 5\%$ NPO 50V cer smd (unrevised 430-470 MHz)	510-3615-220
	100 pF NPO $\pm 5\%$ 50V cer smd (all others)	510-3601-101
C 575	10 pF $\pm 5\%$ NPO 50V cer smd (unrevised 430-470 MHz)	510-3615-100

Ref No.	Description	Part No.
	.01 $\mu$ F X7R $\pm 10\%$ 50V cer smd (all others)	510-3605-103
C 576	15 pF $\pm 5\%$ NPO 50V cer smd (unrevised 430-470 MHz)	510-3602-150
	100 pF NPO $\pm 5\%$ 50V cer smd (all others)	510-3601-101
C 577	15 pF $\pm 5\%$ NPO 50V cer smd (unrevised 430-470 MHz)	510-3602-150
	10 $\mu$ F 25V tantalum smd (all others)	510-2627-100
C 578	15 pF $\pm 5\%$ NPO 50V cer smd (unrevised 430-470 MHz)	510-3615-150
	.01 $\mu$ F X7R $\pm 10\%$ 50V cer smd (all others)	510-3605-103
C 579	100 pF NPO $\pm 5\%$ 50V cer smd (unrevised 430-470 MHz)	510-3601-101
	7.5 pF $\pm 5\%$ NPO 50V cer smd (revised 430-470 MHz)	510-3615-759
	6.8 pF $\pm 5\%$ NPO 50V cer smd (470-512 MHz)	510-3615-689
C 581	0.1 $\mu$ F X7R $\pm 10\%$ 50V cer smd	510-3605-104
C 600	.01 $\mu$ F X7R $\pm 10\%$ 50V cer smd	510-3605-103
C 601	470 pF X7R $\pm 10\%$ 50V cer smd	510-3605-471
C 602	68 pF $\pm 5\%$ NPO 50V cer smd	510-3601-680
C 603	.01 $\mu$ F X7R $\pm 10\%$ 50V cer smd	510-3605-103
C 604	68 pF $\pm 5\%$ NPO 50V cer smd	510-3601-680
C 605	6.8 $\mu$ F 35V tantalum smd (470-512 MHz, 40 watt)	510-2635-689
C 606	100 pF $\pm 5\%$ NPO 50V cer smd (470-512 MHz, 40 watt)	510-3601-101
C 607	6.8 $\mu$ F 35V tantalum smd	510-2635-689
C 608	100 pF $\pm 5\%$ NPO 50V cer smd	510-3601-101
C 609	.01 $\mu$ F X7R $\pm 10\%$ 50V cer smd (40 watt)	510-3605-103
	4.7 pF $\pm 5\%$ NPO 50V cer smd (25 watt)	510-3615-479
C 610	100 pF $\pm 5\%$ NPO 50V cer smd	510-3601-101
C 611	68 pF $\pm 5\%$ NPO 50V cer smd	510-3601-680
C 612	.01 $\mu$ F X7R $\pm 10\%$ 50V cer smd	510-3605-103
C 613	100 pF $\pm 5\%$ NPO 50V cer smd	510-3601-101
C 614	100 pF $\pm 10\%$ 50V hi Q cer smd	510-3663-101
C 615	56 pF 250V mini mica (430-470 MHz)	510-0019-560
	47 pF 250V mini mica (470-512 MHz)	510-0019-470

## UHF RF AND PA BOARDS (CONT'D)

Ref No.	Description	Part No.
C 616	33 pF $\pm 5\%$ NPO 50V cer smd (430-470 MHz, 25 watt)	510-3615-330
	24 pF $\pm 5\%$ NPO 50V cer smd (430-470 MHz, 40 watt)	510-3615-240
	47 pF $\pm 5\%$ NPO 50V cer smd (470-512 MHz, 25 watt)	510-3615-470
	24 pF $\pm 5\%$ NPO 50V cer smd (470-512 MHz, 40 watt)	510-3615-240
C 617	47 pF 250V mini mica	510-0019-470
C 618	5.6 pF $\pm 5\%$ NPO 50V cer smd (430-470 MHz)	510-3615-569
	4.3 pF $\pm 5\%$ NPO 50V cer smd (470-512 MHz)	510-3615-439
C 619	5.1 pF $\pm 5\%$ NPO 805 smd (430-470 MHz)	510-3615-519
	4.3 pF $\pm 5\%$ NPO 50V cer smd (470-512 MHz)	510-3615-439
C 620	2.7 pF $\pm 5\%$ NPO 50V cer smd	510-3615-279
C 621	2.7 pF $\pm 5\%$ NPO 50V cer smd (430-470 MHz)	510-3615-279
C 622	5.1 pF $\pm 5\%$ NPO 50V cer smd (430-470 MHz)	510-3615-519
	3.3 pF $\pm 5\%$ NPO 50V cer smd (470-512 MHz)	510-3615-339
C 623	4.7 pF $\pm 5\%$ NPO 50V cer smd (430-470 MHz)	510-3615-479
	3.3 pF $\pm 5\%$ NPO 50V cer smd (470-512 MHz)	510-3615-339
C 624	4.7 pF $\pm 5\%$ NPO 50V cer smd (430-470 MHz)	510-3615-479
	3.3 pF $\pm 5\%$ NPO 50V cer smd (470-512 MHz)	510-3615-339
C 625	2.7 pF $\pm 5\%$ NPO 50V cer smd	510-3615-279
C 626	5.6 pF $\pm 5\%$ NPO 50V cer smd (430-470 MHz)	510-3615-569
	4.3 pF $\pm 5\%$ NPO 50V cer smd (470-512 MHz)	510-3615-439
C 627	33 pF $\pm 5\%$ NPO 50V cer smd (430-470 MHz, 25 watt)	510-3615-330
	27 pF $\pm 5\%$ NPO 50V cer smd (430-470 MHz, 40 watt)	510-3615-270
	47 pF $\pm 5\%$ NPO 50V cer smd (470-512 MHz, 25 watt)	510-3615-470
	27 pF $\pm 5\%$ NPO 50V cer smd (470-512 MHz, 40 watt)	510-3615-270

Ref No.	Description	Part No.
C 628	3.9 pF $\pm 5\%$ NPO 50V cer smd (430-470 MHz)	510-3615-399
	3.0 pF $\pm 5\%$ NPO 50V cer smd (470-512 MHz)	510-3615-309
C 629	3.9 pF $\pm 5\%$ NPO 50V cer smd (430-470 MHz)	510-3615-399
	3.0 pF $\pm 5\%$ NPO 50V cer smd (470-512 MHz)	510-3615-309
C 630	2.2 pF $\pm 5\%$ NPO 50V cer smd (430-470 MHz)	510-3615-229
	1.5 pF $\pm 5\%$ NPO 50V cer smd (470-512 MHz)	510-3615-159
C 631	33 pF $\pm 5\%$ NPO 50V cer smd	510-3615-330
C 632	56 pF 250V mini mica (430-470 MHz, 40 watt)	510-0019-560
	27 pF 250V mini mica (470-512 MHz, 40 watt)	510-0019-270
C 633	47 pF 250V mini mica (430-470 MHz, 40 watt)	510-0019-470
	43 pF 250V mini mica (470-512 MHz, 40 watt)	510-0019-430
C 634	2.2 pF $\pm 5\%$ NPO 50V cer smd (430-470 MHz)	510-3615-229
	2.7 pF $\pm 5\%$ NPO 50V cer smd (470-512 MHz)	510-3615-279
C 635	3.3 pF $\pm 5\%$ NPO 50V cer smd (430-470 MHz)	510-3615-339
	2.7 pF $\pm 5\%$ NPO 50V cer smd (470-512 MHz)	510-3615-279
C 636	3.3 pF $\pm 5\%$ NPO 50V cer smd (430-470 MHz)	510-3615-339
C 637	18 pF 250V mini mica (430-470 MHz, 40W)	510-0019-180
	15 pF 250V mini mica (470-512 MHz, 40W)	510-0019-150
C 638	56 pF 250V mini mica (430-470 MHz)	510-0019-560
	47 pF 250V mini mica (470-512 MHz)	510-0019-470
C 640	47 pF 250V mini mica	510-0019-470
C 641	33 pF $\pm 5\%$ NPO 50V cer smd	510-3615-330
C 642	6.8 pF $\pm 5\%$ NPO 50V cer smd (430-470 MHz, 25 watt)	510-3615-689
	56 pF 250V mini mica (430-470 MHz, 40 watt)	510-0019-560



## UHF RF AND PA BOARDS (CONT'D)

Ref No.	Description	Part No.
	4.7 pF $\pm 5\%$ NPO 50V cer smd (470-512 MHz, 25 watt)	510-3615-479
	27 pF 250V mini mica (470-512 MHz, 40 watt)	510-0019-270
C 643	3.9 pF $\pm 5\%$ NPO 50V cer smd (430-470 MHz)	510-3615-399
	2.7 pF $\pm 5\%$ NPO 50V cer smd (470-512 MHz)	510-3615-279
C 644	12 pF $\pm 5\%$ NPO 50V cer smd (430-470 MHz, 40 watt)	510-3615-120
	6.8 pF $\pm 5\%$ NPO 50V cer smd (470-512 MHz, 40 watt)	510-3615-689
C 645	47 pF 250V mini mica (430-470 MHz, 40 watt)	510-0019-470
	39 pF 250V mini mica (470-512 MHz, 40 watt)	510-0019-390
C 646	10 pF $\pm 5\%$ NPO 50V cer smd (430-470 MHz, 25 watt)	510-3615-100
	43 pF 250V mini mica (430-470 MHz, 40 watt)	510-0019-430
	27 pF 250V mini mica (470-512 MHz, 25 watt)	510-0019-270
	27 pF 250V mini mica (470-512 MHz, 40 watt)	510-0019-270
C 647	12 pF $\pm 5\%$ NPO 50V cer smd	510-3615-120
C 648	100 pF $\pm 5\%$ NPO 50V cer smd	510-3615-101
C 649	68 pF $\pm 5\%$ NPO 50V cer smd	510-3601-680
C 650	12 pF $\pm 5\%$ NPO 50V cer smd (25 watt)	510-3615-120
	22 pF $\pm 5\%$ NPO 50V cer smd (40 watt)	510-3615-220
C 651	2.2 pF $\pm 5\%$ NPO 50V cer smd	510-3615-229
C 652	30 pF $\pm 5\%$ NPO 50V cer smd	510-3615-300
C 653	68 pF $\pm 5\%$ NPO 50V cer smd	510-3601-680
C 655	3.3 pF $\pm 5\%$ NPO 50V cer smd (430-470 MHz)	510-3615-339
	3.0 pF $\pm 5\%$ NPO 50V cer smd (470-512 MHz)	510-3615-309
C 657	15 pF $\pm 10\%$ 50V hi Q cer smd (430-470 MHz, 40W)	510-3663-150
	7.5 pF $\pm 5\%$ NPO 50V cer smd (470-512 MHz, 40W)	510-3615-759
C 658	4.7 pF $\pm 5\%$ NPO 50V cer smd (470-512 MHz, 40W)	510-3601-479
C 800	100 pF NPO $\pm 5\%$ 50V cer smd	510-3601-101

Ref No.	Description	Part No.
C 801	100 pF NPO $\pm 5\%$ 50V cer smd	510-3601-101
C 802	100 pF NPO $\pm 5\%$ 50V cer smd	510-3601-101
C 803	100 pF NPO $\pm 5\%$ 50V cer smd	510-3601-101
C 804	100 pF NPO $\pm 5\%$ 50V cer smd	510-3601-101
C 805	100 pF NPO $\pm 5\%$ 50V cer smd	510-3601-101
C 807	.01 $\mu$ F X7R $\pm 10\%$ 50V cer smd	510-3605-103
C 808	100 pF NPO $\pm 5\%$ 50V cer smd	510-3601-101
C 809	150 pF NPO $\pm 5\%$ 50V cer smd	510-3601-151
C 810	100 pF NPO $\pm 5\%$ 50V cer smd	510-3601-101
C 811	.01 $\mu$ F X7R $\pm 10\%$ 50V cer smd	510-3605-103
C 812	100 pF NPO $\pm 5\%$ 50V cer smd	510-3601-101
C 813	.01 $\mu$ F X7R $\pm 10\%$ 50V cer smd	510-3605-103
C 814	4.7 $\mu$ F 10V tantalum smd	510-2624-479
C 815	.01 $\mu$ F X7R $\pm 10\%$ 50V cer smd	510-3605-103
C 816	.001 $\mu$ F X7R $\pm 10\%$ 50V cer smd	510-3605-102
C 817	100 pF NPO $\pm 5\%$ 50V cer smd	510-3601-101
C 818	9.1 pF $\pm 5\%$ NPO 50V cer smd (430-470 MHz)	510-3601-919
	8.2 pF $\pm 5\%$ NPO 50V cer smd (470-512 MHz)	510-3615-829
C 819	1.0 $\mu$ F 10V tantalum smd	510-2624-109
C 820	100 pF NPO $\pm 5\%$ 50V cer smd	510-3601-101
C 821	.001 $\mu$ F X7R $\pm 10\%$ 50V cer smd	510-3605-102
C 822	100 pF NPO $\pm 5\%$ 50V cer smd	510-3601-101
C 823	.01 $\mu$ F X7R $\pm 10\%$ 50V cer smd	510-3605-103
C 824	100 pF NPO $\pm 5\%$ 50V cer smd	510-3601-101
C 825	1.0 $\mu$ F 10V tantalum smd	510-2624-109
C 826	6.8 pF NPO $\pm 5\%$ 50V cer smd	510-3601-689
C 827	9.1 pF $\pm 5\%$ NPO 50V cer smd (430-470 MHz)	510-3601-919
	6.8 pF $\pm 5\%$ NPO 50V cer smd (470-512 MHz)	510-3615-689
C 828	.01 $\mu$ F X7R $\pm 10\%$ 50V cer smd	510-3605-103
C 829	100 pF NPO $\pm 5\%$ 50V cer smd	510-3601-101
C 830	.01 $\mu$ F X7R $\pm 10\%$ 50V cer smd	510-3605-103
C 831	1.0 $\mu$ F 10V tantalum smd	510-2624-109
C 832	.01 $\mu$ F X7R $\pm 10\%$ 50V cer smd	510-3605-103
C 833	100 pF NPO $\pm 5\%$ 50V cer smd	510-3601-101
C 834	.22 $\mu$ F X7R $\pm 10\%$ 50V cer smd	510-3607-224
C 835	.01 $\mu$ F NPO $\pm 2\%$ 50V cer smd	510-3617-103
C 836	4700 pF NPO $\pm 2\%$ 50V cer smd	510-3616-472
C 837	.01 $\mu$ F NPO $\pm 2\%$ 50V cer smd	510-3617-103
C 838	4.7 $\mu$ F 10V tantalum smd	510-2624-479
C 839	100 pF NPO $\pm 5\%$ 50V cer smd	510-3601-101
C 840	.01 $\mu$ F X7R $\pm 10\%$ 50V cer smd	510-3605-103

## UHF RF AND PA BOARDS (CONT'D)

Ref No.	Description	Part No.
C 841	.001 $\mu$ F X7R $\pm$ 10% 50V cer smd	510-3605-102
C 842	3.9 pF $\pm$ 5% NPO 50V cer smd (revised 430-470 MHz)	510-3615-399
	8.2 pF $\pm$ 5% NPO 50V cer smd (all others)	510-3615-829
CR 200	Pin switching diode	523-1504-001
CR 201	Band switching diode	523-1504-035
CR 202	Band switching diode	523-1504-035
CR 203	Switching diode SOT-23	523-1504-002
CR 204	Band switching diode	523-1504-035
CR 205	Band switching diode	523-1504-035
CR 206	Switching diode SOT-23	523-1504-002
CR 207	Pin switching diode	523-1504-001
CR 208	Pin switching diode	523-1504-001
CR 209	Pin switching diode	523-1504-001
CR 210	Pin switching diode	523-1504-001
CR 211	Dual switching diode SOT-23	523-1504-023
CR 212	Dual switching diode SOT-23	523-1504-023
CR 500	Switching diode SOT-23	523-1504-002
CR 501	Dual switching diode SOT-233	523-1504-023
CR 502	Dual switching diode SOT-23	523-1504-023
CR 503	Switching diode SOT-23	523-1504-002
CR 504	Switching diode SOT-23 (unrevised 430-470 MHz) 5.1V zener SOT-23 (revised 430-470 MHz) 4.7V zener SOT-23 (470-512 MHz, 40W only)	523-2016-519 523-2016-479
CR 505	Dual switching diode SOT-23 (470-512 MHz)	523-1504-023
CR 506	Switching diode SOT-23 (470-512 MHz)	523-1504-002
CR 507	Dual switching diode SOT-23 (470-512 MHz)	523-1504-023
CR 600	Transient suppressor	523-2906-001
CR 601	Pin diode	523-1504-032
CR 602	HC diode	523-1504-016
CR 603	Pin diode	523-1504-032
CR 800	Switching diode SOT-23	523-1504-002
CR 801	Switching diode SOT-23	523-1504-002
CR 802	5.1V zener SOT-23 (unrevised 430-470 MHz)	523-2016-519
EP 001	Transistor ground tab	017-2225-527

Ref No.	Description	Part No.
EP 001	Ferrite bead smd (470-512 MHz)	517-2503-010
EP 002	Ferrite bead smd (470-512 MHz)	517-2503-010
EP 003	Ferrite bead smd (470-512 MHz)	517-2503-010
EP 200	Mini crystal pin insulator	010-0345-280
EP 500	Ferrite bead smd (430-470 MHz)	517-2503-001
EP 501	Ferrite bead smd (430-470 MHz)	517-2503-010
EP 501	.055 ID x .015 teflon tubing	058-0053-515
EP 600	Ferrite bead smd	517-2503-010
EP 601	Ferrite bead smd	517-2503-010
EP 602	Ferrite bead smd	517-2503-010
EP 603	Ferrite bead smd	517-2503-010
EP 606	Ferrite bead, .296 x.296	517-2002-006
F 500	4 amp fuse smd very fast blow	534-5000-140
J 201	Connector, 2 x 10 pin male (RF bd)	515-7100-944
J 501	Connector 1 x 8 pin male (RF bd)	515-7100-942
J 600	Connector, 8-pin female	515-7102-115
J 601	Antenna jack, right angle	515-3011-020
L 200	0.5in long smd resonator	542-9004-005
L 201	0.5in long smd resonator	542-9004-005
L 202	15 nH inductor (430-470 MHz)	542-9003-157
	12 nH inductor (470-512 MHz)	542-9003-127
L 203	12 nH inductor	542-9003-127
L 204	0.5in long smd resonator	542-9004-005
L 205	47 nH inductor (430-470 MHz)	542-9003-477
	56 nH inductor (470-512 MHz)	542-9003-567
L 206	0.5in long smd resonator	542-9004-005
L 207	15 nH inductor	542-9003-157
L 208	.68 $\mu$ H smd inductor	542-9000-688
L 209	12 nH inductor	542-9003-127
L 210	22 nH inductor	542-9003-227
L 211	12 nH inductor	542-9003-127
L 213	.68 $\mu$ H smd inductor	542-9000-688
L 215	.68 $\mu$ H smd inductor	542-9000-688

## UHF RF AND PA BOARDS (CONT'D)

Ref No.	Description	Part No.
L 217	.27 $\mu$ H $\pm$ 5% smd inductor	542-9000-278
L 218	455 kHz variable with cap	542-1012-010
L 219	.22 $\mu$ H $\pm$ 5% smd	542-9000-228
L 220	Smd inductor	542-9003-277
L 500	5T 18.5 nH smd air core inductor (unrevised 430-470 MHz)	542-0030-005
	6T 17.5 nH smd air core inductor (all others)	542-0030-006
L 501	5T 18.5 nH smd air core inductor (unrevised 430-470 MHz)	542-0030-005
	3T 24 AWG .080 id inductor (revised 430-470 MHz)	542-0030-003
	2T 24 AWG .080 id inductor (470-512 MHz)	542-0030-002
L 502	12.5 nH smd air core inductor (unrevised 430-470 MHz)	542-0030-004
	3T 24 AWG .080 id inductor (revised 430-470 MHz)	542-0030-003
	2T 24 AWG .080 id inductor (470-512 MHz)	542-0030-002
L 503	9T 35.5 nH smd air core inductor (unrevised 430-470 MHz)	542-0030-009
	2T 24 AWG .080 id inductor (all others)	542-0030-002
L 504	1T 2.5 nH smd air core inductor	542-0030-001
L 505	8.0 nH smd air core inductor (unrevised 430-470 MHz)	542-0030-003
	2T 24 AWG .080 id inductor (all others)	542-0030-002
L 506	8.0 nH smd air core inductor (unrevised 430-470 MHz)	542-0030-003
	9T 35.5 nH smd air core inductor (all others)	542-0030-009
L 507	8.0 nH smd air core inductor (430-470 MHz)	542-0030-003
L 600	4T .1 ID inductor	542-0020-044
L 601	4T .1 ID inductor	542-0020-044
L 602	4T .080 ID inductor	542-0020-034
L 603	3T .060 ID inductor (430-470 MHz)	542-0020-013
	3T .1 ID inductor (470-512 MHz)	542-0020-043
L 604	3T .1 ID inductor (430-470 MHz)	542-0020-043

Ref No.	Description	Part No.
	3T .12 ID inductor (470-512 MHz)	016-0020-053
L 605	4T .1 ID inductor	542-0020-044
L 606	3T .1 ID inductor	542-0020-043
L 607	7T 35.5 nH air core inductor (430-470 MHz, 40W)	542-0030-007
	9T 35.5 nH air core inductor (all others)	542-0030-009
L 608	9T 35.5 nH air core inductor	542-0030-009
L 800	22 nH inductor	542-9003-227
L 801	12 nH inductor	542-9003-127
L 802	39 nH inductor	542-9003-397
MP 013	.120 isodamp foam	018-1132-019
MP 131	Shim substrate	010-0345-450
MP 208	1/4 in. coil shield	578-0003-001
MP 213	1/4 in. coil shield	578-0003-001
MP 215	1/4 in. coil shield	578-0003-001
MP 509	Heat sink sleeving (430-470 MHz)	016-2229-001
MP 900	Can, VCO	017-2225-752
P 001	Power connector assembly, dual	023-4110-012
PC 200	PC board, RF Unrevised 430-470 MHz	035-9840-200
	All others	035-9840-250
PC 600	PC board, PA 430-470 MHz, 25 watt	035-9843-500
	470-512 MHz, 25 watt	035-9843-550
	All 40 watt	035-9844-520
Q 200	PNP general purpose	576-0003-612
Q 201	NPN low noise medium power	576-0003-636
Q 202	N-channel dual MOSFET	576-0006-234
Q 203	PNP general purpose	576-0003-612
Q 204	NPN low noise med power amp	576-0003-636
Q 205	NPN digital w/resistors	576-0003-616
Q 206	NPN digital w/resistors	576-0003-616
Q 207	VHF/UHF amp	576-0003-634
Q 500	PNP power Darlington (unrevised 430-470 MHz)	576-0007-013
	NPN low noise amp (all others)	576-0001-300

## UHF RF AND PA BOARDS (CONT'D)

Ref No.	Description	Part No.
Q 501	NPN general purpose (unrevised 430-470 MHz)	576-0003-658
	PNP power Darlington (all others)	576-0007-013
Q 502	NPN general purpose	576-0003-658
Q 503	NPN general purpose (unrevised 430-470 MHz)	576-0003-658
	PNP general purpose (all others)	576-0003-612
Q 504	PNP general purpose (unrevised 430-470 MHz)	576-0003-612
	NPN general purpose (all others)	576-0003-658
Q 505	NPN general purpose	576-0003-658
Q 506	NPN low noise amp (unrevised 430-470 MHz)	576-0003-618
	PNP general purpose (all others)	576-0003-612
Q 507	NPN low noise amp (unrevised 430-470 MHz)	576-0003-618
	NPN general purpose (all others)	576-0003-658
Q 508	NPN UHF 1.5W amp (unrevised 430-470 MHz)	576-0004-401
	NPN gernal purpose (all others)	576-0003-658
Q 509	N-channel FET UHF 7W amp (unrevised 430-470 MHz)	576-0006-120
	NPN low noise amp (all others)	576-0003-618
Q 510	PNP med power switch (unrevised 430-470 MHz)	576-0002-057
	NPN low noise amp (all others)	576-0003-618
Q 511	N-channel RF power MOSFET (470-512 MHz)	576-0006-450
Q 512	NPN high current amp (unrevised 430-470 MHz)	576-0006-027
	NPN UHF 10W amp (all others)	576-0002-070
Q 513	NPN low noise amp (unrevised 430-470 MHz)	576-0001-300
	PNP med power switch (all others)	576-0002-057

Ref No.	Description	Part No.
Q 514	PNP general purpose (unrevised 430-470 MHz)	576-0003-612
	NPN low noise amp (all others)	576-0001-300
Q 515	NPN low noise amp (unrevised 430-470 MHz)	576-0001-300
	NPN high current amp (all others)	576-0006-027
Q 516	PNP general purpose (unrevised 430-470 MHz)	576-0003-612
	NPN low noise amp (all others)	576-0001-300
Q 517	NPN general purpose (unrevised 430-470 MHz)	576-0003-658
	PNP general purpose (all others)	576-0003-612
Q 600	NPN 50W amplifier	576-0004-402
Q 601	NPN 50W amplifier	576-0004-402
Q 602	NPN general purpose amp	576-0003-658
Q 800	NPN low noise amp	576-0001-300
Q 801	NPN low noise med power amp	576-0003-636
R 200	1.0k ohm $\pm 5\%$ 1/8W smd	569-0105-102
R 201	10k ohm $\pm 5\%$ 1/8W smd	569-0105-103
R 202	10k ohm $\pm 5\%$ 1/8W smd	569-0105-103
R 203	10k ohm $\pm 5\%$ 1/8W smd	569-0105-103
R 204	10k ohm $\pm 5\%$ 1/8W smd	569-0105-103
R 205	1.0k ohm $\pm 5\%$ 1/8W smd	569-0105-102
R 206	3.9k ohm $\pm 5\%$ 1/8W smd	569-0105-392
R 207	100 ohm $\pm 5\%$ 1/8W smd	569-0105-101
R 208	4.7k ohm $\pm 5\%$ 1/8W smd	569-0105-472
R 209	470 ohm $\pm 5\%$ 1/8W smd	569-0105-471
R 210	10k ohm $\pm 5\%$ 1/8W smd	569-0105-103
R 211	10k ohm $\pm 5\%$ 1/8W smd	569-0105-103
R 212	10k ohm $\pm 5\%$ 1/8W smd	569-0105-103
R 213	10k ohm $\pm 5\%$ 1/8W smd	569-0105-103
R 214	330 ohm $\pm 5\%$ 1/8W smd (430-470 MHz)	569-0105-331
	270 ohm $\pm 5\%$ 1/8W smd (470-512 MHz)	569-0105-271
R 215	10k ohm $\pm 5\%$ 1/8W smd	569-0105-103
R 216	390 ohm $\pm 5\%$ 1/8W smdl	569-0105-391
R 217	47k ohm $\pm 5\%$ 1/8W smd	569-0105-473
R 218	10k ohm $\pm 5\%$ 1/8W smd	569-0105-103

## UHF RF AND PA BOARDS (CONT'D)

Ref No.	Description	Part No.
R 219	100 ohm $\pm 5\%$ 1/8W smd	569-0105-101
R 220	100 ohm $\pm 5\%$ 1/8W smd	569-0105-101
R 221	1.0k ohm $\pm 5\%$ 1/8W smd	569-0105-102
R 222	3.3k ohm $\pm 5\%$ 1/8W smd	569-0105-332
R 223	4.7k ohm $\pm 5\%$ 1/8W smd	569-0105-472
R 224	1.0k ohm $\pm 5\%$ 1/8W smd	569-0105-102
R 225	270 ohm $\pm 5\%$ 1/8W smd	569-0105-271
R 226	18 ohm $\pm 5\%$ 1/8W smd	569-0105-180
R 227	270 ohm $\pm 5\%$ 1/8W smd	569-0105-271
R 228	8.2k ohm $\pm 5\%$ 1/8W smd	569-0105-822
R 229	Zero ohm $\pm 5\%$ 1/8W smd	569-0105-001
R 231	4.7k ohm $\pm 5\%$ 1/8W smd	569-0105-472
R 232	4.7k ohm $\pm 5\%$ 1/8W smd	569-0105-472
R 233	22k ohm $\pm 5\%$ 1/8W smd	569-0105-223
R 234	22k ohm $\pm 5\%$ 1/8W smd	569-0105-223
R 237	20k ohm $\pm 5\%$ 1/8W smd	569-0105-203
R 238	20k ohm $\pm 5\%$ 1/8W smd	569-0105-203
R 239	510 ohm $\pm 5\%$ 1/8W smd	569-0105-511
R 240	510 ohm $\pm 5\%$ 1/8W smd	569-0105-511
R 241	20k ohm $\pm 5\%$ 1/8W smd	569-0105-203
R 242	20k ohm $\pm 5\%$ 1/8W smd	569-0105-203
R 243	10 ohm $\pm 5\%$ 1/8W smd	569-0105-100
R 244	15k ohm $\pm 5\%$ 1/8W smd	569-0105-153
R 245	680 ohm $\pm 5\%$ 1/8W smd	569-0105-681
R 246	390 ohm $\pm 5\%$ 1/8W smd	569-0105-391
R 247	4.7k ohm $\pm 5\%$ 1/8W smd	569-0105-472
R 248	180 ohm $\pm 5\%$ 1/8W smd	569-0105-181
R 249	47 ohm $\pm 5\%$ 1/8W smd	569-0105-470
R 250	390 ohm $\pm 5\%$ 1/8W smd	569-0105-391
R 251	100 ohm $\pm 5\%$ 1/8W smd	569-0105-101
R 252	100 ohm $\pm 5\%$ 1/8W smd	569-0105-101
R 253	3.3k ohm $\pm 5\%$ 1/8W smd	569-0105-332
R 254	2.2k ohm $\pm 5\%$ 1/8W smd	569-0105-222
R 255	56k ohm $\pm 5\%$ 1/8W smd	569-0105-563
R 256	27k ohm $\pm 5\%$ 1/8W smd	569-0105-273
R 257	62k ohm $\pm 5\%$ 1/8W smd	569-0105-623
R 258	10k ohm $\pm 5\%$ 1/8W smd	569-0105-103
R 259	330 ohm $\pm 5\%$ 1/8W smd	569-0105-331
R 260	100 ohm $\pm 5\%$ 1/8W smd (430-470 MHz)	569-0115-101
R 261	10 ohm $\pm 5\%$ 1/8W smd (430-470 MHz)	569-0115-100
R 500	2.2k ohm $\pm 5\%$ 1/8W smd	569-0105-222
R 501	10k ohm $\pm 5\%$ 1/8W smd	569-0105-103

Ref No.	Description	Part No.
R 502	10k ohm $\pm 5\%$ 1/8W smd	569-0105-103
R 503	10k ohm $\pm 5\%$ 1/8W smd (430-470 MHz)	569-0105-103
R 504	1.0k ohm $\pm 5\%$ 1/8W smd (430-470 MHz)	569-0105-102
	10k ohm $\pm 5\%$ 1/8W smd (470-512 MHz)	569-0105-103
R 505	10k ohm $\pm 5\%$ 1/8W smd	569-0105-103
R 506	1.0k ohm $\pm 5\%$ 1/8W smd (unrevised 430-470 MHz)	569-0105-102
	10k ohm $\pm 5\%$ 1/8W smd (all others)	569-0105-103
R 507	1.0k ohm $\pm 5\%$ 1/8W smd	569-0105-102
R 508	220k ohm $\pm 5\%$ 1/8W smd (unrevised 430-470 MHz)	569-0105-224
	10k ohm $\pm 5\%$ 1/8W smd (all others)	569-0105-103
R 509	10k ohm $\pm 5\%$ 1/8W smd	569-0105-103
R 510	1.2k ohm $\pm 5\%$ 1/8W smd (unrevised 430-470 MHz)	569-0105-122
	10k ohm $\pm 5\%$ 1/8W smd (all others)	569-0105-103
R 511	120 ohm $\pm 5\%$ 1/8W smd (unrevised 430-470 MHz)	569-0105-121
	680 ohm $\pm 5\%$ 1/8W smd (all others)	569-0105-681
R 512	47k ohm $\pm 5\%$ 1/8W smd (unrevised 430-470 MHz)	569-0105-473
	1.0k ohm $\pm 5\%$ 1/8W smd (all others)	569-0105-102
R 513	1.0k ohm $\pm 5\%$ 1/8W smd (unrevised 430-470 MHz)	569-0105-102
	220k ohm $\pm 5\%$ 1/8W smd (all others)	569-0105-224
R 514	47k ohm $\pm 5\%$ 1/8W smd (unrevised 430-470 MHz)	569-0105-473
R 515	10k ohm $\pm 5\%$ 1/8W smd	569-0105-103
R 516	4.7k ohm $\pm 5\%$ 1/8W smd (unrevised 430-470 MHz)	569-0105-472
	1.2k ohm $\pm 5\%$ 1/8W smd (all others)	569-0105-122
R 517	10k ohm $\pm 5\%$ 1/8W smd (unrevised 430-470 MHz)	569-0105-103
	120 ohm $\pm 5\%$ 1/8W smd (all others)	569-0105-121

## UHF RF AND PA BOARDS (CONT'D)

Ref No.	Description	Part No.
R 518	100 ohm $\pm 5\%$ 1/8W smd (unrevised 430-470 MHz)	569-0105-101
	47k ohm $\pm 5\%$ 1/8W smd (all others)	569-0105-473
R 519	2.7k ohm $\pm 5\%$ 1/8W smd (unrevised 430-470 MHz)	569-0105-272
	1.0k ohm $\pm 5\%$ 1/8W smd (all others)	569-0105-102
R 520	47 ohm $\pm 5\%$ 1/8W smd (unrevised 430-470 MHz)	569-0105-470
	47k ohm $\pm 5\%$ 1/8W smd (all others)	569-0105-473
R 521	47 ohm $\pm 5\%$ 1/8W smd (unrevised 430-470 MHz)	569-0105-470
	4.7k ohm $\pm 5\%$ 1/8W smd (all others)	569-0105-472
R 522	1.2k ohm $\pm 5\%$ 1/8W smd (unrevised 430-470 MHz)	569-0105-122
	4.7k ohm $\pm 5\%$ 1/8W smd (all others)	569-0105-472
R 523	270 ohm $\pm 5\%$ 1/8W smd (unrevised 430-470 MHz)	569-0105-271
	10k ohm $\pm 5\%$ 1/8W smd (all others)	569-0105-103
R 524	47 ohm $\pm 5\%$ 1/8W smd (unrevised 430-470 MHz)	569-0105-470
	47k ohm $\pm 5\%$ 1/8W smd (all others)	569-0105-473
R 525	10k ohm $\pm 5\%$ 1/8W smd (unrevised 430-470 MHz)	569-0105-103
	47k ohm $\pm 5\%$ 1/8W smd (all others)	569-0105-473
R 526	10k ohm $\pm 5\%$ 1/8W smd (unrevised 430-470 MHz)	569-0105-103
	3.3k ohm $\pm 5\%$ 1/8W smd (all others)	569-0105-332
R 527	10 ohm $\pm 5\%$ 1/8W smd (unrevised 430-470 MHz)	569-0105-100
	5k ohm smd top adj (all others)	562-0135-502
R 528	47 ohm $\pm 5\%$ 1/8W smd (unrevised 430-470 MHz)	569-0105-470
	10k ohm $\pm 5\%$ 1/8W smd (all others)	569-0105-103

Ref No.	Description	Part No.
R 529	10 ohm $\pm 5\%$ 1/8W smd (unrevised 430-470 MHz)	569-0105-100
	68 ohm $\pm 5\%$ 1/8W smd (all others)	569-0115-680
R 530	1.8k ohm $\pm 5\%$ 1/8W smd (unrevised 430-470 MHz)	569-0105-182
	68 ohm $\pm 5\%$ 1/8W smd (all others)	569-0115-680
R 531	1.8k ohm $\pm 5\%$ 1/8W smd (unrevised 430-470 MHz)	569-0105-182
	10k ohm $\pm 5\%$ 1/8W smd (all others)	569-0105-103
R 532	18 ohm $\pm 5\%$ 1/8W smd (unrevised 430-470 MHz)	569-0105-180
	15 ohm $\pm 5\%$ 1/8W smd (all others)	569-0115-150
R 533	510 ohm $\pm 5\%$ 1/8W smd (unrevised 430-470 MHz)	569-0105-511
	10k ohm $\pm 5\%$ 1/8W smd (all others)	569-0105-103
R 534	100k ohm $\pm 5\%$ 1/8W smd (unrevised 430-470 MHz)	569-0105-104
	33 ohm $\pm 5\%$ 1/8W smd (all others)	569-0105-330
R 535	100k ohm $\pm 5\%$ 1/8W smd (unrevised 430-470 MHz)	569-0105-104
	1.5k ohm $\pm 5\%$ 1/8W smd (all others)	569-0105-152
R 536	100k ohm $\pm 1\%$ 1/8W smd (unrevised 430-470 MHz)	569-0111-501
	1.2k ohm $\pm 5\%$ 1/8W smd (all others)	569-0105-122
R 537	1.0k ohm $\pm 5\%$ 1/8W smd (unrevised 430-470 MHz)	569-0105-102
	51 ohm $\pm 5\%$ 1W smd (all others)	569-0175-510
R 538	17.8k ohm $\pm 1\%$ 1/8W smd (unrevised 430-470 MHz)	569-0111-425
	510 ohm $\pm 5\%$ 1/8W smd (all others)	569-0105-511
R 539	42.2k ohm $\pm 1\%$ 1/8W smd (unrevised 430-470 MHz)	569-0111-461
	100k ohm $\pm 5\%$ 1/8W smd (all others)	569-0105-104

## UHF RF AND PA BOARDS (CONT'D)

Ref No.	Description	Part No.
R 540	10k ohm $\pm 5\%$ 1/8W smd (unrevised 430-470 MHz)	569-0105-103
	100k ohm $\pm 5\%$ 1/8W smd (all others)	569-0105-104
R 541	54.9k ohm $\pm 1\%$ 1/8W smd (unrevised 430-470 MHz)	569-0111-472
	100k ohm $\pm 1\%$ 1/8W smd (all others)	569-0111-501
R 542	7.5k ohm $\pm 1\%$ 1/8W smd (unrevised 430-470 MHz)	569-0111-385
	100 ohm $\pm 5\%$ 1/8W smd (all others)	569-0115-101
R 543	12.1k ohm $\pm 1\%$ 1/8W smd (unrevised 430-470 MHz)	569-0111-409
	1.0k ohm $\pm 5\%$ 1/8W smd (all others)	569-0105-102
R 544	10 ohm $\pm 5\%$ 1/8W smd	569-0115-100
R 545	17.8k ohm $\pm 1\%$ 1/8W smd	569-0111-425
R 546	100 ohm $\pm 5\%$ 1/8W smd (unrevised 430-470 MHz)	569-0105-101
	42.2k $\pm 1\%$ 1/8W smd (all others)	569-0111-461
R 547	10k ohm $\pm 5\%$ 1/8W smd	569-0105-103
R 548	54.9k ohm $\pm 1\%$ 1/8W smd	569-0111-472
R 549	7.5k ohm $\pm 1\%$ 1/8W smd	569-0111-385
R 550	10k ohm $\pm 5\%$ 1/8W smd (unrevised 430-470 MHz)	569-0105-103
	12.1k ohm $\pm 1\%$ 1/8W smd (all others)	569-0111-409
R 551	10k ohm $\pm 5\%$ 1/8W smd (unrevised 430-470 MHz)	569-0105-103
R 552	10k ohm $\pm 5\%$ 1/8W smd (unrevised 430-470 MHz)	569-0105-103
R 553	10k ohm $\pm 5\%$ 1/8W smd (unrevised 430-470 MHz)	569-0105-103
R 554	150 ohm $\pm 5\%$ 1/8W smd (unrevised 430-470 MHz)	569-0105-151
R 555	180 ohm $\pm 5\%$ 1/8W smd (unrevised 430-470 MHz)	569-0105-181
R 556	47k ohm $\pm 5\%$ 1/8W smd (unrevised 430-470 MHz)	569-0105-473
R 557	47k ohm $\pm 5\%$ 1/8W smd (unrevised 430-470 MHz)	569-0105-473
R 558	2.2k ohm $\pm 5\%$ 1W smd (unrevised 430-470 MHz)	569-0175-222

Ref No.	Description	Part No.
R 559	2.2k ohm $\pm 5\%$ 1W smd (unrevised 430-470 MHz)	569-0175-222
R 600	.030 ohm $\pm 5\%$ 2W WW smd	569-2019-307
R 601	10k ohm $\pm 5\%$ thermistor	569-3013-007
R 602	220k ohm $\pm 5\%$ 1/8W smd	569-0105-224
R 603	220k ohm $\pm 5\%$ 1/8W smd	569-0105-224
R 604	100 ohm $\pm 5\%$ .75W smd	569-0135-101
R 605	330 ohm $\pm 5\%$ 1/8W smd	569-0105-331
R 606	100k ohm $\pm 5\%$ 1/8W smd (430-470 MHz, 40W)	569-0105-104
	68k ohm $\pm 5\%$ 1/8W smd (all others)	569-0105-683
R 607	100k ohm $\pm 5\%$ 1/8W smd (all 25W)	569-0105-104
	75k ohm $\pm 5\%$ 1/8W smd (430-470 MHz 40W)	569-0105-753
	56k ohm $\pm 5\%$ 1/8W smd (470-512 MHz 40W)	569-0105-563
R 608	220k ohm $\pm 5\%$ 1/8W smd	569-0105-224
R 609	100 ohm $\pm 5\%$ .75W smd	569-0135-101
R 610	100 ohm $\pm 5\%$ .75W smd	569-0135-101
R 611	4.7k ohm $\pm 5\%$ 1/8W smd	569-0105-472
R 612	330 ohm $\pm 5\%$ 1W smd (430-470 MHz 40W)	569-0175-331
	100 ohm $\pm 5\%$ 1W smd (470-512 MHz 40W)	569-0175-101
R 613	470 ohm $\pm 5\%$ 1W smd (25 watt and 470-512 MHz 40W)	569-0175-471
	100 ohm $\pm 5\%$ 1W smd (430-470 MHz 40 watt)	569-0175-101
R 614	330 ohm $\pm 5\%$ 1W smd (430-470 MHz 40 watt)	569-0175-331
R 615	330 ohm $\pm 5\%$ 1W smd (430-470 MHz 40 watt)	569-0175-331
R 616	330 ohm $\pm 5\%$ 1W smd (430-470 MHz 40 watt)	569-0175-331
R 800	20k ohm $\pm 5\%$ 1/8W smd	569-0105-203
R 801	20k ohm $\pm 5\%$ 1/8W smd	569-0105-203
R 802	10k ohm $\pm 5\%$ 1/8W smd	569-0105-103
R 803	20k ohm $\pm 5\%$ 1/8W smd	569-0105-203
R 804	4.7k ohm $\pm 5\%$ 1/8W smd	569-0105-472
R 805	10k ohm $\pm 5\%$ 1/8W smd	569-0105-103
R 806	20k ohm $\pm 5\%$ 1/8W smd	569-0105-203

## 800/900 MHz RF AND PA BOARDS

Ref No.	Description	Part No.
R 807	4.7k ohm $\pm 5\%$ 1/8W smd	569-0105-472
R 808	10k ohm $\pm 5\%$ 1/8W smd	569-0105-103
R 809	20k ohm $\pm 5\%$ 1/8W smd	569-0105-203
R 810	4.7k ohm $\pm 5\%$ 1/8W smd	569-0105-472
R 811	10k ohm $\pm 5\%$ 1/8W smd	569-0105-103
R 812	20k ohm $\pm 5\%$ 1/8W smd	569-0105-203
R 813	10k ohm $\pm 5\%$ 1/8W smd	569-0105-103
R 814	20k ohm $\pm 5\%$ 1/8W smd	569-0105-203
R 815	10k ohm $\pm 5\%$ 1/8W smd	569-0105-103
R 816	20k ohm $\pm 5\%$ 1/8W smd	569-0105-203
R 817	10k ohm $\pm 5\%$ 1/8W smd	569-0105-103
R 818	10k ohm $\pm 5\%$ 1/8W smd	569-0105-103
R 819	Zero ohm $\pm 5\%$ 1/8W smd	569-0105-001
R 820	Zero ohm $\pm 5\%$ 1/8W smd	569-0105-001
R 821	Zero ohm $\pm 5\%$ 1/8W smd	569-0105-001
R 822	10k ohm $\pm 5\%$ 1/8W smd	569-0105-103
R 823	33k ohm $\pm 5\%$ 1/8W smd	569-0105-333
R 824	Zero ohm $\pm 5\%$ 1/8W smd	569-0105-001
R 825	100 ohm $\pm 5\%$ 1/8W smd	569-0105-101
R 826	10k ohm $\pm 5\%$ 1/8W smd	569-0105-103
R 827	4.7k ohm $\pm 5\%$ 1/8W smd	569-0105-472
R 828	Zero ohm $\pm 5\%$ 1/8W smd	569-0105-001
R 829	4.7k ohm $\pm 5\%$ 1/8W smd	569-0105-472
R 830	100 ohm $\pm 5\%$ 1/8W smd	569-0105-101
R 831	100 ohm $\pm 5\%$ 1/8W smd	569-0105-101
R 832	1.0k ohm $\pm 5\%$ 1/8W smd	569-0105-102
R 833	15k ohm $\pm 5\%$ 1/8W smd	569-0105-153
R 834	12k ohm $\pm 5\%$ 1/8W smd	569-0105-123
R 835	100 ohm $\pm 5\%$ 1/8W smd	569-0105-101
R 836	18 ohm $\pm 5\%$ 1/8W smd	569-0105-180
R 837	68 ohm $\pm 5\%$ 1/8W smd	569-0105-680
R 838	24k ohm $\pm 5\%$ 1/8W smd	569-0105-243
R 839	39 ohm $\pm 5\%$ 1/8W smd	569-0105-390
R 840	10k ohm $\pm 5\%$ 1/8W smd	569-0105-103
R 841	10k ohm $\pm 5\%$ 1/8W smd	569-0105-103
R 842	150 ohm $\pm 5\%$ 1/8W smd	569-0105-151
R 843	150 ohm $\pm 5\%$ 1/8W smd	569-0105-151
R 844	1.0k ohm $\pm 5\%$ 1/8W smd	569-0105-102
R 845	10 ohm $\pm 5\%$ 1/8W smd	569-0105-100
R 846	5.6k ohm $\pm 5\%$ 1/8W smd	569-0105-562
R 847	18 ohm $\pm 5\%$ 1/8W smd	569-0105-180
R 848	18k ohm $\pm 5\%$ 1/8W smd	569-0105-183
R 849	470k ohm $\pm 5\%$ 1/8W smd	569-0105-474
R 850	100 ohm $\pm 5\%$ 1/8W smd	569-0105-101
R 851	47k ohm $\pm 5\%$ 1/8W smd	569-0105-473

Ref No.	Description	Part No.
R 852	1.0k ohm $\pm 5\%$ 1/8W smd	569-0105-102
R 853	10k ohm $\pm 5\%$ 1/8W smd	569-0105-103
R 854	10k ohm $\pm 5\%$ 1/8W smd	569-0105-103
R 855	150 ohm $\pm 5\%$ 1/8W smd	569-0105-151
	(revised 430-470 MHz)	
	47 ohm $\pm 5\%$ 1/8W smd	569-0105-470
	(all others)	
R 856	82 ohm $\pm 5\%$ 1/8W smd	569-0105-820
U 201	FM IF system SA676DK	544-2002-037
U 500	Op amp, dual 2904	544-2019-004
U 501	Regulator, 8V 0.5A 78M08	544-2003-081
U 502	Regulator, adj 180mA TK11900	544-2603-093
U 800	Shift register, 8-stage 4094	544-3016-094
U 801	Shift register, 8-stage 4094	544-3016-094
U 802	Potentiometer, 4-chnl AD8403	544-0004-211
U 803	Op amp, dual 2904	544-2019-004
U 804	Synthesizer SA7025	544-3954-027
U 806	TCXO, 14.85 MHz $\pm 2.0$ ppm	518-7009-523
Z 202	450 kHz 9 kHz bw ceramic filter	532-2006-034
Z 204	45 MHz 4-pole crystal filter	532-0009-027
Z 205	450 khz, 20 kHz bw ceramic filter	532-2004-013
Z 206	450 khz, 20 kHz bw ceramic filter	532-2004-013

Ref No	Description	Part No.
<b>800/900 MHz RF AND PA BOARDS</b>		
A 020	Pwr connector assembly includes: .001 $\mu$ F 500V feedthrough Contact (2) Shield Connector body 13 AWG tinned copper wire	510-3151-102 515-9033-006 017-2227-031 515-9033-012 597-0271-013
A 533	Stabilization board, Q651 (800/900 MHz, 30W only) includes: .01 $\mu$ F X7R $\pm 10\%$ 50V cer smd .01 $\mu$ H smd inductor 33 ohm resistors	023-9884-531 510-3606-103 542-9001-107
A 900	VCO module, 800 MHz VCO module, 900 MHz	023-9880-901 023-9890-901



## 800/900 MHz RF AND PA BOARDS (CONT'D)

Ref No	Description	Part No.	Ref No	Description	Part No.
C 202	12 pF NPO $\pm 5\%$ cer smd (800 MHz models)	510-3601-120	C 271	15 pF NPO $\pm 5\%$ 50V cer smd (800 MHz models)	510-3601-150
	10 pF $\pm 5\%$ NPO 50V cer smd (900 MHz models)	510-3615-100		27 pF NPO $\pm 5\%$ 50V cer smd (900 MHz models)	510-3601-270
C 214	8.2 pF $\pm 5\%$ NPO 50V cer smd	510-3615-829	C 272	100 pF NPO $\pm 5\%$ 50V cer smd (800 MHz models)	510-3601-101
C 222	.01 $\mu$ F X7R $\pm 10\%$ 50V cer smd	510-3605-103		.01 $\mu$ F X7R $\pm 10\%$ 50V cer smd (900 MHz models)	510-3605-103
C 223	.01 $\mu$ F X7R $\pm 10\%$ 50V cer smd	510-3605-103	C 274	.001 $\mu$ F X7R $\pm 10\%$ 50V cer smd	510-3605-102
C 224	39 pF $\pm 5\%$ NPO 50V cer smd	510-3615-390	C 275	.01 $\mu$ F X7R $\pm 10\%$ 50V cer smd	510-3605-103
C 225	.01 $\mu$ F X7R $\pm 10\%$ 50V cer smd	510-3605-103	C 276	.01 $\mu$ F X7R $\pm 10\%$ 50V cer smd	510-3605-103
C 226	39 pF $\pm 5\%$ NPO 50V cer smd	510-3615-390	C 277	.01 $\mu$ F X7R $\pm 10\%$ 50V cer smd	510-3605-103
C 227	1.8 pF $\pm 5\%$ NPO 50V cer smd (800 MHz models)	510-3615-189	C 278	.01 $\mu$ F X7R $\pm 10\%$ 50V cer smd	510-3605-103
	2.2 pF $\pm 5\%$ NPO 50V cer smd (900 MHz models)	510-3615-229	C 280	.01 $\mu$ F X7R $\pm 10\%$ 50V cer smd	510-3605-103
C 231	39 pF NPO $\pm 5\%$ 50V cer smd	510-3601-390	C 281	.01 $\mu$ F X7R $\pm 10\%$ 50V cer smd	510-3605-103
C 232	56 pF NPO $\pm 5\%$ 50V cer smd	510-3601-560	C 282	.01 $\mu$ F X7R $\pm 10\%$ 50V cer smd	510-3605-103
C 244	.01 $\mu$ F X7R $\pm 10\%$ 50V cer smd	510-3605-103	C 283	.01 $\mu$ F X7R $\pm 10\%$ 50V cer smd	510-3605-103
C 245	100 pF $\pm 5\%$ NPO 50V cer smd	510-3615-101	C 284	.01 $\mu$ F X7R $\pm 10\%$ 50V cer smd	510-3605-103
C 246	30 pF $\pm 5\%$ NPO 50V cer smd (800 MHz models)	510-3615-300	C 285	.01 $\mu$ F X7R $\pm 10\%$ 50V cer smd	510-3605-103
	16 pF NPO $\pm 5\%$ 50V cer smd (900 MHz models)	510-3601-160	C 286	.01 $\mu$ F X7R $\pm 10\%$ 50V cer smd	510-3605-103
C 247	39 pF $\pm 5\%$ NPO 50V cer smd	510-3615-390	C 287	33 pF NPO $\pm 5\%$ 50V cer smd (800 MHz models)	510-3601-330
C 248	.01 $\mu$ F X7R $\pm 10\%$ 50V cer smd	510-3605-103		47 pF NPO $\pm 5\%$ 50V cer smd (900 MHz models)	510-3601-470
C 249	39 pF $\pm 5\%$ NPO 50V cer smd	510-3615-390	C 288	7.5 pF $\pm 5\%$ NPO 50V cer smd	510-3601-759
C 250	.01 $\mu$ F X7R $\pm 10\%$ 50V cer smd	510-3605-103	C 289	.01 $\mu$ F X7R $\pm 10\%$ 50V cer smd	510-3605-103
C 255	100 pF NPO $\pm 5\%$ 50V cer smd	510-3601-101	C 290	24 pF NPO $\pm 5\%$ 50V cer smd (800 MHz models)	510-3601-240
C 264	3.9 pF NPO $\pm 5\%$ 50V cer smd (800 MHz models)	510-3601-399		36 pF NPO $\pm 5\%$ 50V cer smd (900 MHz models)	510-3601-360
	3.3 pF NPO $\pm 5\%$ 50V cer smd (900 MHz models)	510-3601-339	C 291	.01 $\mu$ F X7R $\pm 10\%$ 50V cer smd	510-3605-103
C 265	47 pF NPO $\pm 5\%$ 50V cer smd	510-3601-470	C 292	.01 $\mu$ F X7R $\pm 10\%$ 50V cer smd	510-3605-103
C 266	11 pF NPO $\pm 5\%$ 50V cer smd (800 MHz models)	510-3601-110	C 293	.01 $\mu$ F X7R $\pm 10\%$ 50V cer smd	510-3605-103
	30 pF NPO $\pm 5\%$ 50V cer smd (900 MHz models)	510-3601-300	C 294	47 $\mu$ F 10V tantalum smd	510-2624-470
C 268	39 pF NPO $\pm 5\%$ 50V cer smd (800 MHz models)	510-3601-390	C 295	.1 $\mu$ F X7R $\pm 10\%$ 50V cer smd	510-3606-104
	150 pF NPO $\pm 5\%$ 50V cer smd (900 MHz models)	510-3601-151	C 296	.01 $\mu$ F X7R $\pm 10\%$ 50V cer smd	510-3605-103
C 269	15 pF NPO $\pm 5\%$ 50V cer smd (900 MHz models only)	510-3601-150	C 297	.01 $\mu$ F X7R $\pm 10\%$ 50V cer smd	510-3605-103
C 270	6.8 pF NPO $\pm 5\%$ 50V cer smd (800 MHz models)	510-3601-689	C 298	.01 $\mu$ F X7R $\pm 10\%$ 50V cer smd	510-3605-103
	27 pF NPO $\pm 5\%$ 50V cer (900 MHz models)	510-3601-270	C 299	.01 $\mu$ F X7R $\pm 10\%$ 50V cer smd	510-3605-103
			C 300	.01 $\mu$ F X7R $\pm 10\%$ 50V cer smd	510-3605-103
			C 301	10 pF $\pm 5\%$ NPO 50V cer smd	510-3602-100
			C 302	.01 $\mu$ F X7R $\pm 10\%$ 50V cer smd	510-3605-103
			C 303	.33 $\mu$ F X7R $\pm 10\%$ 16V cer smd	510-3631-334
			C 304	.01 $\mu$ F X7R $\pm 10\%$ 50V cer smd	510-3605-103
			C 305	100 pF NPO $\pm 5\%$ 50V cer smd	510-3601-101
			C 306	100 pF NPO $\pm 5\%$ 50V cer smd	510-3601-101

## 800/900 MHz RF AND PA BOARDS (CONT'D)

Ref No	Description	Part No.	Ref No	Description	Part No.
C 500	39 pF NPO $\pm 5\%$ 50V cer smd	510-3601-390	C 599	.047 $\mu$ F X7R $\pm 10\%$ 50V cer smd	510-3605-473
C 501	.1 $\mu$ F X7R $\pm 10\%$ 50V cer smd	510-3606-104	C 600	.018 $\mu$ F X7R $\pm 10\%$ cer smd	510-3605-183
C 502	.01 $\mu$ F X7R $\pm 10\%$ 50V cer smd	510-3605-103	C 601	39 pF $\pm 5\%$ NPO 50V cer smd	510-3615-390
C 503	39 pF NPO $\pm 5\%$ 50V cer smd	510-3601-390	C 603	1 $\mu$ F $\pm 10\%$ 16V 50V cer smd	510-3606-105
C 504	.1 $\mu$ F X7R $\pm 10\%$ 50V cer smd	510-3606-104	C 604	39 pF $\pm 5\%$ NPO 50V cer smd	510-3615-390
C 505	.01 $\mu$ F X7R $\pm 10\%$ 50V cer smd	510-3605-103	C 605	.018 $\mu$ F X7R $\pm 10\%$ 50V cer smd	510-3605-183
C 511	39 pF NPO $\pm 5\%$ 50V cer smd	510-3601-390	C 606	1 $\mu$ F $\pm 10\%$ 16V 50V cer smd	510-3606-105
C 513	.1 $\mu$ F X7R $\pm 10\%$ 50V cer smd	510-3606-104	C 607	39 pF $\pm 5\%$ NPO 50V cer smd	510-3615-390
C 514	39 pF NPO $\pm 5\%$ 50V cer smd	510-3601-390	C 608	.018 $\mu$ F X7R $\pm 10\%$ 50V cer smd	510-3605-183
C 515	5.6 pF NPO $\pm 5\%$ 50V cer smd	510-3601-569	C 609	39 pF $\pm 5\%$ NPO 50V cer smd	510-3615-390
C 516	16 pF NPO $\pm 5\%$ 50V cer smd	510-3601-160	C 610	.018 $\mu$ F X7R $\pm 10\%$ 50V cer smd	510-3605-183
C 517	39 pF NPO $\pm 5\%$ 50V cer smd	510-3601-390	C 611	1 $\mu$ F $\pm 10\%$ 16V 50V cer smd	510-3606-105
C 518	1.6 pF $\pm 5\%$ NPO 50V cer smd	510-3615-169	C 612	.01 $\mu$ F X7R $\pm 10\%$ 50V cer smd	510-3605-103
C 519	6.8 pF NPO $\pm 5\%$ 50V cer smd	510-3615-689	C 613	56 pF $\pm 10\%$ 50V high q smd	510-3653-560
C 520	39 pF NPO $\pm 5\%$ 50V cer smd	510-3601-390	C 614	4 pF 250V mini mica (30W 800/900 MHz models)	510-0019-409
C 522	4.3 pF NPO $\pm 5\%$ 50V cer smd	510-3615-439	C 615	1 $\mu$ F $\pm 10\%$ 16V 50V cer smd	510-3606-105
C 523	10 pF NPO $\pm 5\%$ 50V cer smd	510-3601-100	C 619	1 $\mu$ F $\pm 10\%$ 16V 50V cer smd	510-3606-105
C 524	39 pF NPO $\pm 5\%$ 50V cer smd	510-3601-390	C 620	1.0 pF $\pm 5\%$ NPO 50V cer smd	510-3615-109
C 525	39 pF NPO $\pm 5\%$ 50V cer smd	510-3601-390	C 621	56 pF $\pm 10\%$ 50V high q smd	510-3653-560
C 526	.01 $\mu$ F X7R $\pm 10\%$ 50V cer smd	510-3605-103	C 622	1.8 pF $\pm 5\%$ NPO 50V cer smd	510-3615-189
C 527	1.6 pF $\pm 5\%$ NPO 50V cer smd	510-3615-169	C 623	12 pF $\pm 5\%$ NPO 50V cer smd	510-3615-120
C 528	.01 $\mu$ F X7R $\pm 10\%$ 50V cer smd	510-3605-103	C 624	3.9 pF $\pm 10\%$ 50V high q smd	510-3653-399
C 529	39 pF NPO $\pm 5\%$ 50V cer smd	510-3601-390	C 625	7.5 pF $\pm 10\%$ 50V high q smd	510-3663-759
C 530	39 pF NPO $\pm 5\%$ 50V cer smd	510-3601-390	C 626	7.5 pF $\pm 10\%$ 50V high q smd	510-3663-759
C 531	1 $\mu$ F $\pm 10\%$ 50V X7R cer smd	510-3606-105	C 627	3.9 pF $\pm 10\%$ 50V high q smd	510-3653-399
C 532	1 $\mu$ F 16V tantalum smd	510-2625-109	C 628	39 pF $\pm 5\%$ NPO 50V cer smd	510-3615-390
C 547	.01 $\mu$ F X7R $\pm 10\%$ 50V cer smd	510-3605-103	C 629	.01 $\mu$ F X7R $\pm 10\%$ 50V cer smd	510-3605-103
C 548	10 $\mu$ F 25V tantalum smd	510-2627-100	C 630	39 pF $\pm 5\%$ NPO 50V cer smd	510-3615-390
C 549	470 $\mu$ F 25V electrolytic	510-4064-471	C 631	39 pF $\pm 5\%$ NPO 50V cer smd	510-3615-390
C 550	.01 $\mu$ F X7R $\pm 10\%$ 50V cer smd	510-3605-103	C 632	39 pF $\pm 5\%$ NPO 50V cer smd	510-3615-390
C 551	39 pF NPO $\pm 5\%$ 50V cer smd	510-3601-390	C 633	10 pF $\pm 5\%$ NPO 50V cer smd (15W 800 MHz/30W 900 MHz)	510-3615-100
C 552	10 $\mu$ F 25V tantalum smd	510-2627-100		12 pF $\pm 5\%$ NPO 50V cer smd (15W 900 MHz)	510-3615-120
C 553	470 $\mu$ F 25V electrolytic	510-4064-471		56 pF $\pm 10\%$ 50V high q smd (30W, 800 MHz)	510-3653-560
C 554	39 pF NPO $\pm 5\%$ 50V cer smd	510-3601-390	C 634	39 pF $\pm 5\%$ NPO 50V cer smd	510-3615-390
C 555	39 pF NPO $\pm 5\%$ 50V cer smd	510-3601-390	C 635	1.8 pF $\pm 5\%$ NPO 50V cer smd	510-3615-189
C 556	4.7 $\mu$ F 10V tantalum smd	510-2624-479	C 636	39 pF $\pm 5\%$ NPO 50V cer smd	510-3615-390
C 557	.01 $\mu$ F X7R $\pm 10\%$ 50V cer smd	510-3605-103	C 637	.018 $\mu$ F X7R k50V cer smd	510-3605-183
C 558	39 pF NPO $\pm 5\%$ 50V cer smd	510-3601-390	C 638	39 pF $\pm 5\%$ NPO 50V cer smd	510-3615-390
C 559	39 pF NPO $\pm 5\%$ 50V cer smd	510-3601-390	C 639	3.6 pF $\pm 5\%$ NPO 50V cer smd	510-3615-369
C 561	4.7 $\mu$ F 10V tantalum smd	510-2624-479	C 640	2.2 $\mu$ F 16V tantalum smd	510-2625-229
C 562	39 pF NPO $\pm 5\%$ 50V cer smd	510-3601-390			
C 563	.01 $\mu$ F X7R $\pm 10\%$ 50V cer smd	510-3605-103			
C 564	39 pF NPO $\pm 5\%$ 50V cer smd	510-3601-390			
C 565	10 $\mu$ F 25V tantalum smd	510-2627-100			
C 566	.01 $\mu$ F X7R $\pm 10\%$ 50V cer smd	510-3605-103			

## 800/900 MHz RF AND PA BOARDS (CONT'D)

Ref No	Description	Part No.	Ref No	Description	Part No.
C 651	3.0 pF $\pm 5\%$ NPO 50V cer smd	510-3615-309	C 833	39 pF $\pm 5\%$ NPO 50V cer smd	510-3615-390
C 652	10 pF 250V mini mica	510-0019-100	C 834	0.1 $\mu$ F X7R $\pm 5\%$ 50V cer smd	510-3610-104
C 653	12 pF 250V mini mica	510-0019-120	C 835	.01 $\mu$ F NPO $\pm 2\%$ 50V cer smd	510-3617-103
C 654	18 pF 250V mini mica (30W, 800 MHz)	510-0019-180	C 836	4700 pF NPO $\pm 2\%$ 50V cer smd	510-3616-472
	12 pF 250V mini mica (30W, 900 MHz)	510-0019-120	C 838	4.7 $\mu$ F 10V tantalum smd	510-2624-479
C 655	18 pF 250V mini mica (30W, 800 MHz)	510-0019-180	C 839	39 pF $\pm 5\%$ NPO 50V cer smd	510-3615-390
	15 pF 250V mini mica (30W, 900 MHz)	510-0019-150	C 840	.01 $\mu$ F X7R $\pm 10\%$ 50V cer smd	510-3605-103
C 656	1.0 to 4.5 pF smd var	512-1008-001	C 841	.001 $\mu$ F X7R $\pm 10\%$ 50V cer smd	510-3605-102
C 657	3.3 pF $\pm 10\%$ 50V high q smd (800 MHz models only)	510-3653-339	C 842	39 pF $\pm 5\%$ NPO 50V cer smd (800 MHz models)	510-3615-390
C 807	.01 $\mu$ F X7R $\pm 10\%$ 50V cer smd	510-3605-103		27 pF $\pm 5\%$ NPO 50V cer smd (900 MHz models)	510-3601-270
C 808	100 pF NPO $\pm 5\%$ 50V cer smd	510-3601-101	C 843	5.6 pF NPO $\pm 5\%$ 50V cer smd	510-3601-569
C 809	330 pF NPO $\pm 5\%$ 50V cer smd (800 MHz models)	510-3601-331	C 844	.01 $\mu$ F X7R $\pm 10\%$ 50V cer smd	510-3605-103
	150 pF NPO $\pm 5\%$ 50V cer smd (900 MHz models)	510-3601-151	C 845	10 pF NPO $\pm 5\%$ 50V cer smd	510-3601-100
C 811	.01 $\mu$ F X7R $\pm 10\%$ 50V cer smd	510-3605-103	C 846	10 pF NPO $\pm 5\%$ 50V cer smd	510-3601-100
C 812	100 pF NPO $\pm 5\%$ 50V cer smd	510-3601-101	C 847	4.7 pF NPO $\pm 5\%$ 50V cer smd	510-3601-479
C 813	.01 $\mu$ F X7R $\pm 10\%$ 50V cer smd	510-3605-103	C 848	39 pF $\pm 5\%$ NPO 50V cer smd	510-3615-390
C 814	10 $\mu$ F 16V tantalum smd	510-2625-100	C 849	47 pF NPO $\pm 5\%$ 50V cer smd (800 MHz models)	510-3601-470
C 815	.01 $\mu$ F X7R $\pm 10\%$ 50V cer smd	510-3605-103		27 pF $\pm 5\%$ NPO 50V cer smd (900 MHz models)	510-3601-270
C 816	.001 $\mu$ F X7R $\pm 10\%$ 50V cer smd	510-3605-102	C 850	39 pF $\pm 5\%$ NPO 50V cer smd	510-3615-390
C 817	100 pF NPO $\pm 5\%$ 50V cer smd	510-3601-101	CR 200	PIN switching diode	523-1504-001
C 818	5.6 pF NPO $\pm 5\%$ 50V cer smd	510-3601-569	CR 203	Switching diode SOT-23	523-1504-002
C 819	1.0 $\mu$ F 10V tantalum smd	510-2624-109	CR 207	PIN switching diode	523-1504-001
C 820	100 pF NPO $\pm 5\%$ 50V cer smd	510-3601-101	CR 208	PIN switching diode	523-1504-001
C 821	.001 $\mu$ F X7R $\pm 10\%$ 50V cer smd	510-3605-102	CR 209	PIN switching diode	523-1504-001
C 822	39 pF $\pm 5\%$ NPO 50V cer smd	510-3615-390	CR 210	PIN switching diode	523-1504-001
C 823	.01 $\mu$ F X7R $\pm 10\%$ 50V cer smd	510-3605-103	CR 500	Switching diode SOT-23 (30W models only)	523-1504-002
C 824	100 pF NPO $\pm 5\%$ 50V cer smd	510-3601-101	CR 501	Switching diode SOT-23	523-1504-002
C 825	1.0 $\mu$ F 10V tantalum smd	510-2624-109	CR 502	Switching diode SOT-23	523-1504-002
C 826	12 pF NPO $\pm 5\%$ cer smd (800 MHz models)	510-3601-120	CR 503	Switching diode SOT-23	523-1504-002
	5.6 pF NPO $\pm 5\%$ 50V cer smd (900 MHz models)	510-3601-569	CR 504	Switching diode SOT-23	523-1504-002
C 827	39 pF $\pm 5\%$ NPO 50V cer smd	510-3615-390	CR 505	Dual sw diode SOT-23	523-1504-023
C 828	.01 $\mu$ F X7R $\pm 10\%$ 50V cer smd	510-3605-103	CR 506	Dual sw diode SOT-23	523-1504-023
C 829	39 pF $\pm 5\%$ NPO 50V cer smd	510-3615-390	CR 600	Transient suppressor	523-2906-001
C 830	.01 $\mu$ F X7R $\pm 10\%$ 50V cer smd	510-3605-103	CR 601	Zener diode 12V	523-2016-120
C 831	1.0 $\mu$ F 10V tantalum smd	510-2624-109	CR 602	PIN diode	523-1504-032
C 832	.01 $\mu$ F X7R $\pm 10\%$ 50V cer smd	510-3605-103	CR 603	HC diode	523-1504-016
			CR 604	PIN diode	523-1504-032
			CR 603	PIN diode	523-1504-032
			CR 800	Switching diode SOT-23	523-1504-002

## 800/900 MHz RF AND PA BOARDS (CONT'D)

Ref No	Description	Part No.	Ref No	Description	Part No.
CR 801	PIN switching diode	523-1504-001		(15W models)	
CR 802	PIN switching diode	523-1504-001		8T 22 AWG .090 ID inductor	542-0016-008
CR 803	5.1V zener SOT-23	523-2016-519		(30W models)	
EP 010	Ferrite noise suppressor (J201/J302)	515-9034-065	L 603	.033 $\mu$ H smd inductor	542-9001-337
EP 200	Crystal pin insulator	010-0345-280	L 604	8.0 nH smd inductor	542-0030-003
EP 500	.055" x .015" teflon tubing	058-0053-515	L 651	8T 22 AWG .090 ID inductor	542-0016-008
EP 501	Ferrite bead	517-2503-002	L 800	.047 $\mu$ H smd inductor	542-9001-477
EP 502	.03" teflon tubing	058-0053-510	L 801	.047 $\mu$ H smd inductor	542-9001-477
EP 502	Ferrite bead	517-2503-002	MP 002	1/4 in. coil shield	578-0003-001
EP 600	Ferrite bead smd	517-2503-010	MP 509	Heat sink sleeving (Q509)	016-2229-001
EP 601	Ferrite bead smd	517-2503-010	MP 600	Jumper strap	017-2224-340
F 500	Fuse, 4A smd very fast blow	534-5000-140	MP 601	RF shield (900 MHz)	537-5001-008
J 201	Connector, 2 x 10 pin male (RF bd)	515-7100-944	P 001	Power connector, dual	See A020
J 501	Connector 1 x 8 pin male (RF bd)	515-7100-942	PC 200	PC board, RF	
J 600	Connector, 8-pin female (PA bd)	515-7102-115		800 MHz models (rev 2)	035-9880-200
J 601	Antenna jack, right angle	515-3011-020		900 MHz models (rev 2)	035-9890-200
L 200	12 nH smd inductor (800 MHz models only)	542-9003-127	PC 500	PC board, power amp	
L 201	39 $\mu$ H smd inductor (800 MHz models only)	542-9003-397		800/900 MHz 15W (rev 2)	035-9882-500
L 207	.047 $\mu$ H smd inductor	542-9001-477		800/900 MHz 30W (rev 3)	035-9884-500
L 213	Variable inductor (800 MHz models)	542-1012-015	Q 200	PNP switching	576-0003-612
	.68 $\mu$ H smd inductor (900 MHz models)	542-9000-688	Q 201	NPN low noise high freq	576-0003-618
L 214	3.9 $\mu$ H inductor (800 MHz models)	542-9000-399	Q 202	NPN low noise high freq	576-0003-618
L 215	Variable inductor (800 MHz models)	542-1012-015	Q 203	PNP switching	576-0003-612
	.68 $\mu$ H smd inductor (900 MHz models)	542-9000-688	Q 205	NPN digital w/resistors	576-0003-616
L 217	.27 $\mu$ H smd inductor	542-9000-278	Q 206	NPN digital w/resistors	576-0003-616
L 218	455 kHz variable w/cap	542-1012-010	Q 207	VHF/UHF amp	576-0003-634
L 219	.22 $\mu$ H inductor	542-9000-228	Q 500	PNP power Darlington	576-0007-013
L 220	0.39 $\mu$ H smd inductor	542-9001-398	Q 501	NPN general purpose	576-0003-658
L 501	8 nH smd inductor	542-0030-003	Q 502	NPN general purpose	576-0003-658
L 502	8 nH smd inductor	542-0030-003	Q 503	NPN general purpose	576-0003-658
L 503	9T 35.5 nH inductor	542-0030-009	Q 504	PNP switching	576-0003-612
L 504	12.5 nH smd inductor	542-0030-004	Q 505	NPN general purpose	576-0003-658
L 601	9T 35.5 nH inductor	542-0030-009	Q 506	NPN low noise amp	576-0003-604
L 602	.033 $\mu$ H smd inductor	542-9001-337	Q 507	NPN 750 mW UHF/800 MHz amp	576-0004-098
			Q 508	PNP switching	576-0003-612
			Q 509	NPN general purpose	576-0003-658
			Q 510	PNP med power amp/switch	576-0002-057
			Q 511	NPN low noise amp	576-0001-300
			Q 512	NPN high current	576-0006-027
			Q 513	NPN low noise amp	576-0001-300
			Q 514	PNP switching	576-0003-612
			Q 600	PNP switching xstr	576-0003-612

## 800/900 MHz RF AND PA BOARDS (CONT'D)

Ref No	Description	Part No.	Ref No	Description	Part No.
Q 602	NPN general purpose	576-0003-658	R 234	22k ohm $\pm 5\%$ 1/8W smd	569-0105-223
Q 651	NPN 806-870 MHz 45W amp	576-0004-817	R 237	20k ohm $\pm 5\%$ 1/8W smd	569-0105-203
Q 800	NPN low noise amp	576-0001-300	R 238	20k ohm $\pm 5\%$ 1/8W smd	569-0105-203
Q 801	NPN low noise high freq	576-0003-618	R 239	510 ohm $\pm 5\%$ 1/8W smd	569-0105-511
Q 802	PNP switching	576-0003-612	R 240	510 ohm $\pm 5\%$ 1/8W smd	569-0105-511
Q 803	NPN digital w/resistors	576-0003-616	R 241	20k ohm $\pm 5\%$ 1/8W smd	569-0105-203
Q 804	NPN digital w/resistors	576-0003-616	R 242	20k ohm $\pm 5\%$ 1/8W smd	569-0105-203
Q 805	NPN digital w/resistors	576-0003-616	R 243	10 ohm $\pm 5\%$ 1/8W smd	569-0105-100
Q 806	PNP switching	576-0003-612	R 244	15k ohm $\pm 5\%$ 1/8W smd	569-0105-153
R 200	1.0k ohm $\pm 5\%$ 1/8W smd	569-0105-102	R 245	680 ohm $\pm 5\%$ 1/8W smd	569-0105-681
R 205	4.7k ohm $\pm 5\%$ 1/8W smd	569-0105-472	R 246	390 ohm $\pm 5\%$ 1/8W smd	569-0105-391
R 206	10k ohm $\pm 5\%$ 1/8W smd	569-0105-103	R 247	4.7k ohm $\pm 5\%$ 1/8W smd	569-0105-472
R 207	100 ohm $\pm 5\%$ 1/8W smd	569-0105-101	R 248	180 ohm $\pm 5\%$ 1/8W smd	569-0105-181
R 208	4.7k ohm $\pm 5\%$ 1/8W smd	569-0105-472	R 249	47 ohm $\pm 5\%$ 1/8W smd	569-0105-470
R 209	220 ohm $\pm 5\%$ 1/8W smd	569-0105-221	R 250	390 ohm $\pm 5\%$ 1/8W smd	569-0105-391
R 210	18 ohm $\pm 5\%$ 1/8W smd	569-0105-180	R 251	100 ohm $\pm 5\%$ 1/8W smd	569-0105-101
R 211	270 ohm $\pm 5\%$ 1/8W smd	569-0105-271	R 252	100 ohm $\pm 5\%$ 1/8W smd	569-0105-101
R 212	270 ohm $\pm 5\%$ 1/8W smd	569-0105-271	R 253	3.3k ohm $\pm 5\%$ 1/8W smd	569-0105-332
R 213	4.7k ohm $\pm 5\%$ 1/8W smd	569-0105-472	R 254	2.2k ohm $\pm 5\%$ 1/8W smd	569-0105-222
R 214	560 ohm $\pm 5\%$ 1/8W smd	569-0105-561	R 255	56k ohm $\pm 5\%$ 1/8W smd	569-0105-563
R 215	150 ohm $\pm 5\%$ 1/8W smd (800 MHz models)	569-0105-151	R 256	27k ohm $\pm 5\%$ 1/8W smd	569-0105-273
	270 ohm $\pm 5\%$ 1/8W smd (900 MHz models)	569-0105-271	R 257	62k ohm $\pm 5\%$ 1/8W smd (800 MHz models)	569-0105-623
R 216	39 ohm $\pm 5\%$ 1/8W smd (800 MHz models)	569-0105-390		47k ohm $\pm 5\%$ 1/8W smd (900 MHz models)	569-0105-473
	18 ohm $\pm 5\%$ 1/8W smd (900 MHz models)	569-0105-180	R 258	10k ohm $\pm 5\%$ 1/8W smd	569-0105-103
R 217	150 ohm $\pm 5\%$ 1/8W smd (800 MHz models)	569-0105-151	R 259	330 ohm $\pm 5\%$ 1/8W smd	569-0105-331
	270 ohm $\pm 5\%$ 1/8W smd (900 MHz models)	569-0105-271	R 500	2.2k ohm $\pm 5\%$ 1/8W smd	569-0105-222
R 218	180 ohm $\pm 5\%$ 1/8W smd (800 MHz models)	569-0105-181	R 501	10k ohm $\pm 5\%$ 1/8W smd	569-0105-103
	100 ohm $\pm 5\%$ 1/8W smd (900 MHz models)	569-0105-101	R 502	11.0k ohm $\pm 1\%$ 1/8W smd (800 MHz models)	569-0101-405
R 219	100 ohm $\pm 5\%$ 1/8W smd	569-0105-101		10.0k ohm $\pm 1\%$ 1/8W smd (900 MHz models)	569-0101-401
R 221	2.2k ohm $\pm 5\%$ 1/8W smd	569-0105-222	R 503	10k ohm $\pm 5\%$ 1/8W smd	569-0105-103
R 222	4.7k ohm $\pm 5\%$ 1/8W smd	569-0105-472	R 504	1.15k ohm $\pm 1\%$ 1/8W smd	569-0101-307
R 226	Zero ohm jumper	569-0105-001	R 505	10k ohm $\pm 5\%$ 1/8W smd	569-0105-103
R 228	8.2k ohm $\pm 5\%$ 1/8W smd	569-0105-822	R 506	1.0k ohm $\pm 5\%$ 1/8W smd	569-0105-102
R 229	Zero ohm jumper	569-0105-001	R 507	1.15k ohm $\pm 1\%$ 1/8W smd	569-0101-307
R 231	4.7k ohm $\pm 5\%$ 1/8W smd	569-0105-472	R 508	220k ohm $\pm 5\%$ 1/8W smd	569-0105-224
R 232	4.7k ohm $\pm 5\%$ 1/8W smd	569-0105-472	R 509	11.0k ohm $\pm 1\%$ 1/8W smd (800 MHz models)	569-0101-405
R 233	22k ohm $\pm 5\%$ 1/8W smd	569-0105-223		10.0k ohm $\pm 1\%$ 1/8W smd (900 MHz models)	569-0101-401
			R 510	1.2k ohm $\pm 5\%$ 1/8W smd	569-0105-122

## 800/900 MHz RF AND PA BOARDS (CONT'D)

Ref No	Description	Part No.
R 511	56 ohm $\pm 5\%$ 1/8W smd (800 MHz models)	569-0105-560
	120 ohm $\pm 5\%$ 1/8W smd (900 MHz models)	569-0105-121
R 512	47k ohm $\pm 5\%$ 1/8W smd	569-0105-473
R 513	1.0k ohm $\pm 5\%$ 1/8W smd	569-0105-102
R 514	47k ohm $\pm 5\%$ 1/8W smd	569-0105-473
R 515	4.7k ohm $\pm 5\%$ 1/8W smd	569-0105-472
R 516	4.7k ohm $\pm 5\%$ 1/8W smd	569-0105-472
R 517	10k ohm $\pm 5\%$ 1/8W smd	569-0105-103
R 518	51 ohm $\pm 5\%$ 1/8W smd	569-0105-510
R 519	5.1k ohm $\pm 5\%$ 1/8W smd	569-0105-512
R 520	1.2k ohm $\pm 5\%$ 1/8W smd	569-0105-122
R 521	100 ohm $\pm 5\%$ 1/8W smd	569-0105-101
R 522	100 ohm $\pm 5\%$ 1/8W smd	569-0105-101
R 523	100 ohm $\pm 5\%$ 1/8W smd	569-0105-101
R 524	10k ohm $\pm 5\%$ 1/8W smd	569-0105-103
R 525	10k ohm $\pm 5\%$ 1/8W smd	569-0105-103
R 526	100 ohm $\pm 5\%$ 1/8W smd	569-0115-101
R 527	10 ohm $\pm 5\%$ 1/8W smd	569-0115-100
R 528	100 ohm $\pm 5\%$ 1/8W smd	569-0115-101
R 529	680 ohm $\pm 5\%$ 1/8W smd	569-0115-681
R 530	10 ohm $\pm 5\%$ 1/8W smd	569-0115-100
R 531	680 ohm $\pm 5\%$ 1/8W smd	569-0115-681
R 533	510 ohm $\pm 5\%$ 1/8W smd	569-0105-511
R 534	100k ohm $\pm 5\%$ 1/8W smd	569-0105-104
R 535	100k ohm $\pm 5\%$ 1/8W smd	569-0105-104
R 536	100k ohm $\pm 1\%$ 1/8W smd	569-0111-501
R 537	1.0k ohm $\pm 5\%$ 1/8W smd	569-0105-102
R 538	17.8k ohm $\pm 1\%$ 1/8W smd	569-0111-425
R 539	42.2k ohm $\pm 1\%$ 1/8W smd	569-0111-461
R 540	10k ohm $\pm 5\%$ 1/8W smd	569-0105-103
R 541	54.9k ohm $\pm 1\%$ 1/8W smd	569-0111-472
R 542	7.5k ohm $\pm 1\%$ 1/8W smd	569-0111-385
R 543	12.1k ohm $\pm 1\%$ 1/8W smd	569-0111-409
R 546	47k ohm $\pm 5\%$ 1/8W smd	569-0105-473
R 547	47k ohm $\pm 5\%$ 1/8W smd	569-0105-473
R 548	1.0k ohm $\pm 5\%$ 1/8W smd	569-0105-102
R 549	1.0k ohm $\pm 5\%$ 1/8W smd	569-0105-102
R 600	470 ohm $\pm 5\%$ 1/8W smd	569-0115-471
R 601	.030 ohm 2W $\pm 5\%$ smd ww (all 15W, 800 MHz 30W)	569-2019-307
	.015 ohm 2W $\pm 5\%$ smd ww (900 MHz, 30W)	569-2019-157

Ref No	Description	Part No.
R 602	220k ohm $\pm 5\%$ 1/8W smd	569-0105-224
R 603	330 ohm $\pm 5\%$ 1/8W smd	569-0105-331
R 604	100 ohm $\pm 5\%$ .75W smd	569-0135-101
R 605	100k ohm $\pm 5\%$ 1/8W smd	569-0105-104
R 606	220k ohm $\pm 5\%$ 1/8W smd	569-0105-224
R 607	220k ohm $\pm 5\%$ 1/8W smd	569-0105-224
R 608	220k ohm $\pm 5\%$ 1/8W smd	569-0105-224
R 609	100 ohm $\pm 5\%$ .75W smd	569-0135-101
R 610	100 ohm $\pm 5\%$ .75W smd	569-0135-101
R 611	4.7k ohm $\pm 5\%$ 1/8W smd	569-0105-472
R 612	1k ohm $\pm 5\%$ 1/8W smd	569-0115-102
R 613	10k ohm $\pm 5\%$ 1/8W smd	569-0115-103
R 614	330 ohm $\pm 5\%$ 1W smd	569-0175-331
R 615	100 ohm $\pm 5\%$ 1/8 smd (15W models)	569-0105-101
	2k ohm $\pm 5\%$ 1W smd (30W models)	569-0175-202
R616	100 ohm $\pm 5\%$ 1/8 smd	569-0105-101
R617	430 ohm $\pm 5\%$ 1/8 smd	569-0115-431
R618	10 ohm $\pm 5\%$ 1/8 smd	569-0115-100
R619	430 ohm $\pm 5\%$ 1/8 smd	569-0115-431
R 800	20k ohm $\pm 5\%$ 1/8W smd	569-0105-203
R 801	20k ohm $\pm 5\%$ 1/8W smd	569-0105-203
R 802	10k ohm $\pm 5\%$ 1/8W smd	569-0105-103
R 803	20k ohm $\pm 5\%$ 1/8W smd	569-0105-203
R 804	4.7k ohm $\pm 5\%$ 1/8W smd	569-0105-472
R 805	10k ohm $\pm 5\%$ 1/8W smd	569-0105-103
R 806	20k ohm $\pm 5\%$ 1/8W smd	569-0105-203
R 807	4.7k ohm $\pm 5\%$ 1/8W smd	569-0105-472
R 808	10k ohm $\pm 5\%$ 1/8W smd	569-0105-103
R 809	20k ohm $\pm 5\%$ 1/8W smd	569-0105-203
R 810	4.7k ohm $\pm 5\%$ 1/8W smd	569-0105-472
R 811	10k ohm $\pm 5\%$ 1/8W smd	569-0105-103
R 812	20k ohm $\pm 5\%$ 1/8W smd	569-0105-203
R 813	10k ohm $\pm 5\%$ 1/8W smd	569-0105-103
R 814	20k ohm $\pm 5\%$ 1/8W smd	569-0105-203
R 815	10k ohm $\pm 5\%$ 1/8W smd	569-0105-103
R 816	20k ohm $\pm 5\%$ 1/8W smd	569-0105-203
R 817	10k ohm $\pm 5\%$ 1/8W smd	569-0105-103
R 818	10k ohm $\pm 5\%$ 1/8W smd	569-0105-103
R 819	Zero ohm jumper	569-0105-001
R 820	Zero ohm jumper	569-0105-001
R 821	Zero ohm jumper	569-0105-001

## AUDIO/LOGIC BOARD

Ref No	Description	Part No.	Ref No	Description	Part No.
R 822	4.7k ohm $\pm 5\%$ 1/8W smd (800 MHz models)	569-0105-472	R 854	10k ohm $\pm 5\%$ 1/8W smd	569-0105-103
	100k ohm $\pm 5\%$ 1/8W smd (900 MHz models)	569-0105-104	R 855	47 ohm $\pm 5\%$ 1/8W smd	569-0105-470
R 823	100k ohm $\pm 5\%$ 1/8W smd	569-0105-104	R 856	1.0k ohm $\pm 5\%$ 1/8W smd	569-0105-102
R 824	Zero ohm jumper	569-0105-001	R 857	1.0k ohm $\pm 5\%$ 1/8W smd	569-0105-102
R 825	560 ohm $\pm 5\%$ 1/8W smd	569-0115-561	R 858	4.7k ohm $\pm 5\%$ 1/8W smd	569-0105-472
R 826	4.7k ohm $\pm 5\%$ 1/8W smd (800 MHz models)	569-0105-472	R 859	10k ohm $\pm 5\%$ 1/8W smd	569-0105-103
	10k ohm $\pm 5\%$ 1/8W smd (900 MHz models)	569-0105-103	R 860	4.7k ohm $\pm 5\%$ 1/8W smd	569-0105-472
R 827	4.7k ohm $\pm 5\%$ 1/8W smd	569-0105-472	R 861	15 ohm $\pm 5\%$ 1/8W smd (800 MHz models)	569-0105-150
R 828	Zero ohm jumper	569-0105-001		0 ohm jumper (900 MHz models)	569-0105-001
R 829	15k ohm $\pm 5\%$ 1/8W smd (800 MHz models)	569-0105-153	R 862	22k ohm $\pm 5\%$ 1/8W smd	569-0105-223
	10k ohm $\pm 5\%$ 1/8W smd (900 MHz models)	569-0105-103	R 863	22k ohm $\pm 5\%$ 1/8W smd	569-0105-223
R 830	100 ohm $\pm 5\%$ 1/8W smd	569-0105-101	RT 601	10k ohm $\pm 5\%$ thermistor	569-3013-007
R 831	100 ohm $\pm 5\%$ 1/8W smd	569-0105-101	S 001	Switch, rotary and push	583-2042-001
R 832	180 ohm $\pm 5\%$ 1/8W smd	569-0105-181	U 201	FM IF system SA676DK	544-2002-037
R 833	15k ohm $\pm 5\%$ 1/8W smd	569-0105-153	U 500	Op amp, dual 2904	544-2019-004
R 834	12k ohm $\pm 5\%$ 1/8W smd	569-0105-123	U 501	Regulator, 8V 0.7A 78M08	544-2003-081
R 835	560 ohm $\pm 5\%$ 1/8W smd	569-0115-561	U 502	Regulator, adjust 180 mA	544-2603-093
R 836	33k ohm $\pm 5\%$ 1/8W smd	569-0105-333	U 600	Power module, 20W 870 MHz (800 MHz models)	544-4001-127
R 837	68k ohm $\pm 5\%$ cer smd	569-0105-683		Power module, 18W 900 MHz (900 MHz models)	544-4001-008
R 838	27k ohm $\pm 5\%$ 1/8W smd (800 MHz models)	569-0105-273	U 800	Shift register, 8-stage 4094	544-3016-094
	24k ohm $\pm 5\%$ 1/8W smd (900 MHz models)	569-0105-243	U 801	Shift register, 8-stage 4094	544-3016-094
R 839	Zero ohm jumper	569-0105-001	U 802	Potentiometer, 4-ch AD8403	544-0004-211
R 840	10k ohm $\pm 5\%$ 1/8W smd	569-0105-103	U 803	Op amp, dual 2904	544-2019-004
R 841	10k ohm $\pm 5\%$ 1/8W smd	569-0105-103	U 804	Synthesizer SA7025	544-3954-027
R 845	10 ohm $\pm 5\%$ 1/8W smd	569-0105-100	U 806	17.5 MHz TCXO $\pm 1.5$ ppm (800 MHz models)	518-7009-521
R 846	10k ohm $\pm 5\%$ 1/8W smd (800 MHz models)	569-0105-103		14.85MHz TCXO $\pm 1.0$ ppm (900 MHz models)	518-7009-524
	11k ohm $\pm 5\%$ 1/8W smd (900 MHz models)	569-0105-113	Z 200	860 MHz 20 MHz bw 3-p filter (800 MHz models)	532-2007-011
R 848	15k ohm $\pm 5\%$ 1/8W smd	569-0105-153		938 MHz 6 MHz bw 3-p filter (900 MHz models)	532-2007-012
R 849	470k ohm $\pm 5\%$ 1/8W smd	569-0105-474	Z 201	860 MHz 20 MHz bw 3-p (800 MHz models)	532-2007-011
R 850	100 ohm $\pm 5\%$ 1/8W smd	569-0105-101		938 MHz 6 MHz bw 3-p filter (900 MHz models)	532-2007-012
R 851	100k ohm $\pm 5\%$ 1/8W smd (800 MHz models)	569-0105-104	Z 202	450 kHz 9 kHz bw ceramic filter	532-2006-034
	47k ohm $\pm 5\%$ 1/8W smd (900 MHz models)	569-0105-473	Z 203	807 MHz 18 MHz bw 2-p filter (800 MHz models)	532-2006-011
R 852	1.0k ohm $\pm 5\%$ 1/8W smd	569-0105-102			
R 853	10k ohm $\pm 5\%$ 1/8W smd	569-0105-103			

## AUDIO/LOGIC BOARD (CONT'D)

Ref No	Description	Part No.
Z 204	888 MHz 3-pole ceramic filter (900 MHz models)	532-2006-042
	52.95 MHz 15 kHz bw 4-p filter (800 MHz models)	532-0009-009
Z 205	45 MHz 7.5 kHz bw 4-p filter (900 MHz models)	532-0009-028
	450 kHz 9 kHz bw ceramic filter	532-2006-034
Z 206	450 kHz ceramic filter	532-2004-016

Ref No	Description	Part No.
<b>AUDIO/LOGIC BOARD (ALL MODELS)</b>		
C 100	.01 $\mu$ F X7R $\pm$ 10% 50V cer smd	510-3605-103
C 101	470 pF NPO $\pm$ 5% cer smd	510-3601-471
C 102	22 pF NPO $\pm$ 5% cer smd	510-3601-220
C 103	22 pF NPO $\pm$ 5% cer smd	510-3601-220
C 104	.1 $\mu$ F X7R $\pm$ 10% 50V cer smd	510-3606-104
C 105	.1 $\mu$ F X7R $\pm$ 10% 50V cer smd	510-3606-104
C 106	.22 $\mu$ F X7R $\pm$ 10% 50V cer smd	510-3606-224
C 107	.1 $\mu$ F X7R $\pm$ 10% 50V cer smd	510-3606-104
C 108	.1 $\mu$ F X7R $\pm$ 10% 50V cer smd	510-3606-104
C 109	470 pF NPO $\pm$ 5% 50V cer smd	510-3601-471
C 110	.01 $\mu$ F X7R $\pm$ 10% 50V cer smd	510-3605-103
C 111	10 $\mu$ F 16V tantalum smd	510-2625-100
C 112	10 $\mu$ F 16V tantalum smd	510-2625-100
C 113	.1 $\mu$ F X7R $\pm$ 10% 50V cer smd	510-3606-104
C 114	.1 $\mu$ F X7R $\pm$ 10% 50V cer smd	510-3606-104
C 115	.1 $\mu$ F X7R $\pm$ 10% 50V cer smd	510-3606-104
C 116	.1 $\mu$ F X7R $\pm$ 10% 50V cer smd	510-3606-104
C 117	.1 $\mu$ F X7R $\pm$ 10% 50V cer smd	510-3606-104
C 118	.1 $\mu$ F X7R $\pm$ 10% 50V cer smd	510-3606-104
C 119	.1 $\mu$ F X7R $\pm$ 10% 50V cer smd	510-3606-104
C 120	.1 $\mu$ F X7R $\pm$ 10% 50V cer smd	510-3606-104
C 121	.1 $\mu$ F X7R $\pm$ 10% 50V cer smd	510-3606-104
C 122	.1 $\mu$ F X7R $\pm$ 10% 50V cer smd	510-3606-104
C 123	47000 $\mu$ F 5.5V	510-4056-001
C 124	.047 $\mu$ F X7R $\pm$ 10% 50V cer smd	510-3605-473
C 125	.047 $\mu$ F X7R $\pm$ 10% 50V cer smd	510-3605-473
C 126	.047 $\mu$ F X7R $\pm$ 10% 50V cer smd	510-3605-473
C 127	.01 $\mu$ F X7R $\pm$ 10% 50V cer smd	510-3605-103

Ref No	Description	Part No.
C 128	220 $\mu$ F X7R $\pm$ 10% 50V cer smd	510-3606-224
C 300	.0012 $\mu$ F X7R $\pm$ 10% 50V cer smd	510-3605-122
C 301	.01 $\mu$ F X7R $\pm$ 10% 50V cer smd	510-3605-103
C 302	.0012 $\mu$ F X7R $\pm$ 10% cer smd	510-3605-122
C 303	.01 $\mu$ F X7R $\pm$ 10% 50V cer smd	510-3605-103
C 304	.033 $\mu$ F X7R $\pm$ 10% 50V cer smd	510-3606-333
C 305	.1 $\mu$ F X7R $\pm$ 10% 50V cer smd	510-3606-104
C 306	.01 $\mu$ F X7R $\pm$ 10% 50V cer smd	510-3605-103
C 307	.0033 $\mu$ F X7R $\pm$ 10% 50V cer smd	510-3605-332
C 308	.01 $\mu$ F X7R $\pm$ 10% 50V cer smd	510-3605-103
C 309	4.7 $\mu$ F 16V tantalum smd	510-2625-479
C 310	.0022 $\mu$ F X7R $\pm$ 10% 50V smd	510-3605-222
C 311	820 pF NPO $\pm$ 5% 50V cer smd	510-3601-821
C 312	.039 $\mu$ F X7R $\pm$ 10% 50V cer smd	510-3605-393
C 313	.01 $\mu$ F X7R $\pm$ 10% 50V cer smd	510-3605-103
C 314	.01 $\mu$ F X7R $\pm$ 10% 50V cer smd	510-3605-103
C 315	4.7 $\mu$ F 10V tantalum smd	510-2624-479
C 316	.0018 $\mu$ F X7R $\pm$ 10% 50V cer smd	510-3605-182
C 317	.01 $\mu$ F X7R $\pm$ 10% 50V cer smd	510-3605-103
C 318	.01 $\mu$ F X7R $\pm$ 10% 50V cer smd	510-3605-103
C 319	1.0 $\mu$ F 35V tantalum smd	510-2628-109
C 320	680 pF $\pm$ 5% NPO 50V cer smd	510-3601-681
C 321	.047 $\mu$ F X7R $\pm$ 10% 50V cer smd	510-3605-473
C 322	4.7 $\mu$ F 16V tantalum smd	510-2625-479
C 323	.047 $\mu$ F X7R $\pm$ 10% 50V cer smd	510-3605-473
C 324	4.7 $\mu$ F 16V tantalum smd	510-2625-479
C 325	.047 $\mu$ F X7R $\pm$ 10% 50V cer smd	510-3605-473
C 326	220 $\mu$ F 25V electrolytic	510-4425-221
C 327	.1 $\mu$ F X7R $\pm$ 10% 50V cer smd	510-3606-104
C 328	1.0 $\mu$ F 35V tantalum smd	510-2628-109
C 329	.047 $\mu$ F X7R $\pm$ 10% 50V cer smd	510-3605-473
C 330	.1 $\mu$ F X7R $\pm$ 10% 50V cer smd	510-3606-104
C 331	.0033 $\mu$ F X7R $\pm$ 10% 50V cer smd	510-3605-332
C 332	.0047 $\mu$ F X7R $\pm$ 10% 50V cer smd	510-3605-472
C 333	.0068 $\mu$ F X7R $\pm$ 10% 50V cer smd	510-3605-682
C 334	4.7 $\mu$ F 16V tantalum smd	510-2625-479
C 335	4.7 $\mu$ F 16V tantalum smd	510-2625-479
C 336	560 pF NPO $\pm$ 5% 50V cer smd	510-3601-561
C 337	.047 $\mu$ F X7R $\pm$ 10% 50V cer smd	510-3605-473
C 338	56 pF NPO $\pm$ 5% 50V cer smd	510-3601-560
C 339	4.7 $\mu$ F 16V tantalum smd	510-2625-479
C 340	.01 $\mu$ F X7R $\pm$ 10% 50V cer smd	510-3605-103
C 341	.1 $\mu$ F X7R $\pm$ 10% 50V cer smd	510-3606-104
C 342	.0033 $\mu$ F X7R $\pm$ 10% 50V cer smd	510-3605-332



## AUDIO/LOGIC BOARD (CONT'D)

Ref No	Description	Part No.	Ref No	Description	Part No.
C 343	.01 $\mu$ F X7R $\pm$ 10% 50V cer smd	510-3605-103	CR 122	18V zener SOT-23	523-2016-180
C 344	.0022 $\mu$ F X7R $\pm$ 10% 50V cer smd	510-3605-222	CR 123	18V zener SOT-23	523-2016-180
C 345	470 pF NPO $\pm$ 5% 50V cer smd	510-3601-471	CR 124	5.6V zener SOT-23	523-2016-569
C 346	.22 $\mu$ F X7R $\pm$ 10% 50V cer smd	510-3606-224	CR 125	5.6V zener SOT-23	523-2016-569
C 347	.01 $\mu$ F X7R $\pm$ 10% 50V cer smd	510-3605-103	CR 126	Switching diode SOT-23	523-1504-002
C 348	4.7 $\mu$ F 16V tantalum smd	510-2625-479	CR 127	5.6V zener SOT-23	523-2016-569
C 349	.047 $\mu$ F X7R $\pm$ 10% 50V cer smd	510-3605-473	CR 128	Switching diode SOT-23	523-1504-002
C 350	.01 $\mu$ F X7R $\pm$ 10% 50V cer smd	510-3605-103	CR 129	5.6V zener SOT-23	523-2016-569
C 351	.01 $\mu$ F X7R $\pm$ 10% 50V cer smd	510-3605-103	CR 300	Dual sw diode SOT-23	523-1504-023
C 352	.22 $\mu$ F X7R $\pm$ 10% 50V cer smd	510-3606-224	CR 301	Dual sw diode SOT-23 (early versions)	523-1504-023
C 353	.22 $\mu$ F X7R $\pm$ 10% 50V cer smd	510-3606-224		Switching diode SOT-23 (later versions w/separate diodes)	523-1504-012
C 354	4.7 $\mu$ F 16V tantalum smd	510-2625-479	CR 302	3.3V zener SOT-23 (early versions)	523-2016-339
C 355	.1 $\mu$ F X7R $\pm$ 10% 50V cer smd	510-3606-104		Switching diode SOT-23 (later versions)	523-1504-012
C 356	.1 $\mu$ F X7R $\pm$ 10% 50V cer smd	510-3606-104	CR 303	18V zener SOT-23	523-2016-180
C 357	.1 $\mu$ F X7R $\pm$ 10% 50V cer smd	510-3606-104	CR 304	Switching diode SOT-23	523-1504-002
C 358	.1 $\mu$ F X7R $\pm$ 10% 50V cer smd	510-3606-104	CR 305	Dual diodes-com anodes	523-1504-024
C 359	.1 $\mu$ F X7R $\pm$ 10% 50V cer smd	510-3606-104	DS 003	LED, green	549-4003-011
C 360	.1 $\mu$ F X7R $\pm$ 10% 50V cer smd	510-3606-104	DS 004	LED, red	549-4003-012
C 361	.1 $\mu$ F X7R $\pm$ 10% 50V cer smd	510-3606-104	F 100	Fuse, 2.0 A smd	534-5001-009
C 362	.1 $\mu$ F X7R $\pm$ 10% 50V cer smd	510-3606-104	F 300	Fuse, 0.6A smd	534-5001-002
C 363	.1 $\mu$ F X7R $\pm$ 10% 50V cer smd	510-3606-104	J 100	Connector, 12-pin (low tier)	515-7111-287
C 364	470 pF X7R $\pm$ 10% 50V cer smd	510-3605-471		Connector, 20-pin (high tier)	515-7111-286
C 365	.1 $\mu$ F X7R $\pm$ 10% 50V cer smd	510-3606-104	J 101	Connector, 6-pin male	515-7111-255
CR 100	18V zener SOT-23	523-2016-180	J 301	Connector, 13-pin male	515-7111-262
CR 101	5.6V zener SOT-23	523-2016-569	J 302	Connector, 20-pin female	515-7111-230
CR 102	5.6V zener SOT-23	523-2016-569	J 303	3.6mm spkr jack enclosed	515-2001-011
CR 103	5.6V zener SOT-23	523-2016-569	J 304	Modular jack, 8-pin spec (mic jk)	515-2006-040
CR 104	5.6V zener SOT-23	523-2016-569	J 305	Connector, 2-pin speaker (low tier)	515-9031-201
CR 105	5.6V zener SOT-23	523-2016-569	MP 101	Isodamp foam	018-1132-019
CR 106	Switching diode SOT-23	523-1504-002	MP 450	Shim substrate	010-0345-450
CR 107	5.6V zener SOT-23	523-2016-569	PC 100	PC board, audio/logic	
CR 108	5.6V zener SOT-23	523-2016-569		Low tier models	035-9800-120
CR 109	5.6V zener SOT-23	523-2016-569		High tier models	035-9800-100
CR 110	5.6V zener SOT-23	523-2016-569	Q 100	N-channel MOSFET DPAK	576-0006-114
CR 111	5.6V zener SOT-23	523-2016-569	Q 101	NPN general purpose	576-0003-658
CR 112	5.6V zener SOT-23	523-2016-569			
CR 113	5.6V zener SOT-23	523-2016-569			
CR 114	Switching diode SOT-23	523-1504-002			
CR 115	5.6V zener SOT-23	523-2016-569			
CR 116	5.6V zener SOT-23	523-2016-569			
CR 118	Switching diode SOT-23	523-1504-002			
CR 119	5.6V zener SOT-23	523-2016-569			
CR 120	Switching diode SOT-23	523-1504-002			
CR 121	Switching diode SOT-23	523-1504-002			

## AUDIO/LOGIC BOARD (CONT'D)

Ref No	Description	Part No.	Ref No	Description	Part No.
Q 102	NPN general purpose	576-0003-658		47k ohm $\pm 5\%$ 1/8W smd (high tier)	569-0105-473
Q 103	PNP low noise amp	576-0003-657	R 120	4.7k ohm $\pm 5\%$ 1/8W smd	569-0105-472
Q 104	NPN digital, w/resistors	576-0003-616	R 121	10k ohm $\pm 5\%$ 1/8W smd	569-0105-103
Q 105	PNP low noise amp	576-0003-657	R 122	10k ohm $\pm 5\%$ 1/8W smd	569-0105-103
Q 106	NPN digital w/resistors	576-0003-616	R 123	47k ohm $\pm 5\%$ 1/8W smd	569-0105-473
Q 107	PNP low noise amp	576-0003-657	R 124	10k ohm $\pm 5\%$ 1/8W smd	569-0105-103
Q 108	NPN general purpose	576-0003-658	R 125	47k ohm $\pm 5\%$ 1/8W smd	569-0105-473
Q 109	NPN general purpose	576-0003-658	R 126	1M ohm $\pm 5\%$ 1/8W smd	569-0105-105
Q 110	NPN general purpose	576-0003-658	R 127	10k ohm $\pm 5\%$ 1/8W smd	569-0105-103
Q 111	NPN digital, w/resistors	576-0003-616	R 128	1.0k ohm $\pm 5\%$ 1/8W smd	569-0105-102
Q 112	NPN general purpose	576-0003-658	R 129	10k ohm $\pm 5\%$ 1/8W smd	569-0105-103
Q 113	PNP low noise amp	576-0003-657	R 130	47k ohm $\pm 5\%$ 1/8W smd	569-0105-473
Q 114	NPN general purpose	576-0003-658	R 131	10k ohm $\pm 5\%$ 1/8W smd	569-0105-103
Q 115	NPN general purpose	576-0003-658	R 132	10k ohm $\pm 5\%$ 1/8W smd	569-0105-103
Q 300	NPN general purpose	576-0003-658	R 133	47k ohm $\pm 5\%$ 1/8W smd	569-0105-473
Q 301	NPN digital, w/resistors	576-0003-616	R 134	47k ohm $\pm 5\%$ 1/8W smd	569-0105-473
Q 302	NPN digital, w/resistors	576-0003-616	R 135	47k ohm $\pm 5\%$ 1/8W smd	569-0105-473
Q 303	NPN digital, w/resistors	576-0003-616	R 136	10k ohm $\pm 5\%$ 1/8W smd	569-0105-103
Q 304	NPN digital, w/resistors	576-0003-616	R 137	470 ohm $\pm 5\%$ 1/8W smd	569-0105-471
Q 305	NPN digital, w/resistors	576-0003-616	R 138	10k ohm $\pm 5\%$ 1/8W smd	569-0105-103
Q 306	NPN general purpose	576-0003-658	R 139	47k ohm $\pm 5\%$ 1/8W smd	569-0105-473
Q 307	NPN digital, w/resistors	576-0003-616	R 140	47k ohm $\pm 5\%$ 1/8W smd (low tier)	569-0105-473
Q 308	NPN digital, w/resistors	576-0003-616		470 ohm $\pm 5\%$ 1/8W smd (high tier)	569-0105-471
Q 309	NPN general purpose	576-0003-658	R 141	10k ohm $\pm 5\%$ 1/8W smd	569-0105-103
R 100	1.0k ohm $\pm 5\%$ 1/8W smd	569-0105-102	R 142	10k ohm $\pm 5\%$ 1/8W smd	569-0105-103
R 101	47k ohm $\pm 5\%$ 1/8W smd	569-0105-473	R 143	2.7k ohm $\pm 5\%$ 1/8W smd	569-0105-272
R 102	10k ohm $\pm 5\%$ 1/8W smd	569-0105-103	R 144	1.0k ohm $\pm 5\%$ 1/8W smd	569-0105-102
R 103	1.0k ohm $\pm 5\%$ 1/8W smd	569-0105-102	R 145	10k ohm $\pm 5\%$ 1/8W smd	569-0105-103
R 104	47k ohm $\pm 5\%$ 1/8W smd	569-0105-473	R 146	470 ohm $\pm 5\%$ 1/8W smd	569-0105-471
R 105	10k ohm $\pm 5\%$ 1/8W smd	569-0105-103	R 147	47k ohm $\pm 5\%$ 1/8W smd	569-0105-473
R 106	4.7k ohm $\pm 5\%$ 1/8W smd	569-0105-472	R 148	10k ohm $\pm 5\%$ 1/8W smd	569-0105-103
R 107	47k ohm $\pm 5\%$ 1/8W smd	569-0105-473	R 149	10k ohm $\pm 5\%$ 1/8W smd	569-0105-103
R 108	680k ohm $\pm 5\%$ 1/8W smd	569-0105-684	R 150	470 ohm $\pm 5\%$ 1/8W smd	569-0105-471
R 109	47k ohm $\pm 5\%$ 1/8W smd	569-0105-473	R 151	470 ohm $\pm 5\%$ 1/8W smd	569-0105-471
R 110	1M ohm $\pm 5\%$ 1/8W smd	569-0105-105	R 152	470 ohm $\pm 5\%$ 1/8W smd	569-0105-471
R 111	10k ohm $\pm 5\%$ 1/8W smd	569-0105-103	R 153	10k ohm $\pm 5\%$ 1/8W smd	569-0105-103
R 112	10k ohm $\pm 5\%$ 1/8W smd	569-0105-103	R 154	470 ohm $\pm 5\%$ 1/8W smd	569-0105-471
R 113	10k ohm $\pm 5\%$ 1/8W smd	569-0105-103	R 155	10k ohm $\pm 5\%$ 1/8W smd	569-0105-103
R 114	Zero ohm smd jumper	569-0105-001	R 156	470 ohm $\pm 5\%$ 1/8W smd	569-0105-471
R 115	10k ohm $\pm 5\%$ 1/8W smd	569-0105-103	R 157	47k ohm $\pm 5\%$ 1/8W smd	569-0105-473
R 116	47k ohm $\pm 5\%$ 1/8W smd	569-0105-473	R 158	470 ohm $\pm 5\%$ 1/8W smd	569-0105-471
R 117	47k ohm $\pm 5\%$ 1/8W smd	569-0105-473	R 159	10k ohm $\pm 5\%$ 1/8W smd	569-0105-103
R 118	470 ohm $\pm 5\%$ 1/8W smd	569-0105-471	R 160	10k ohm $\pm 5\%$ 1/8W smd	569-0105-103
R 119	10k ohm $\pm 5\%$ 1/8W smd (low tier)	569-0105-103	R 161	24.3k ohm $\pm 1\%$ 1/8W smd	569-0111-438
			R 162	10k ohm $\pm 5\%$ 1/8W smd	569-0105-103

## AUDIO/LOGIC BOARD (CONT'D)

Ref No	Description	Part No.
R 164	10k ohm $\pm 5\%$ 1/8W smd	569-0105-103
R 165	47k ohm $\pm 5\%$ 1/8W smd	569-0105-473
R 166	10k ohm $\pm 5\%$ 1/8W smd	569-0105-103
R 167	47k ohm $\pm 5\%$ 1/8W smd	569-0105-473
R 168	3.40k ohm $\pm 1\%$ 1/8W smd	569-0111-352
R 169	22k ohm $\pm 5\%$ 1/8W smd	569-0105-223
R 170	4.7k ohm $\pm 5\%$ 1/8W smd	569-0115-472
R 171	10k ohm $\pm 5\%$ 1/8W smd	569-0105-103
R 172	22k ohm $\pm 5\%$ 1/8W smd	569-0105-223
R 173	22k ohm $\pm 5\%$ 1/8W smd	569-0105-223
R 174	4.7k ohm $\pm 5\%$ 1/8W smd	569-0105-472
R 175	4.7k ohm $\pm 5\%$ 1/8W smd	569-0105-472
R 176	10k ohm $\pm 5\%$ 1/8W smd	569-0105-103
R 177	100 ohm $\pm 5\%$ 1/8W smd	569-0105-101
R 178	47k ohm $\pm 5\%$ 1/8W smd	569-0105-473
R 179	100 ohm $\pm 5\%$ 1/8W smd	569-0115-101
R 180	100 ohm $\pm 5\%$ 1/8W smd	569-0115-101
R 181	10k ohm $\pm 5\%$ 1/8W smd	569-0105-103
R 182	10k ohm $\pm 5\%$ 1/8W smd	569-0105-103
R 183	4.7k ohm $\pm 5\%$ 1/8W smd	569-0105-472
R 184	4.7k ohm $\pm 5\%$ 1/8W smd	569-0105-472
R 185	4.7k ohm $\pm 5\%$ 1/8W smd	569-0105-472
R 186	20k ohm $\pm 5\%$ 1/8W smd	569-0105-203
R 187	20k ohm $\pm 5\%$ 1/8W smd	569-0105-203
R 189	100k ohm $\pm 5\%$ 1/8W smd	569-0105-104
R 190	10k ohm $\pm 1\%$ 1/8W smd	569-0101-401
R 191	470 ohm $\pm 5\%$ 1/8W smd	569-0105-471
R 192	1k ohm $\pm 5\%$ 1/8W smd	569-0105-102
R 193	4.7k ohm $\pm 5\%$ 1/8W smd	569-0105-472
R 194	10k ohm $\pm 5\%$ 1/8W smd	569-0105-103
R 196	10k ohm $\pm 5\%$ 1/8W smd	569-0105-103
R 197	10k ohm $\pm 5\%$ 1/8W smd (high tier)	569-0115-103
	1.0k ohm $\pm 5\%$ 1/8W smd (low tier)	569-0105-102
R 198	Zero ohm smd jumper	569-0105-001
R 199	10k ohm $\pm 5\%$ 1/8W smd	569-0115-103
R 200	1.0k ohm $\pm 5\%$ 1/8W smd	569-0105-102
R 300	6.8k ohm $\pm 5\%$ 1/8W smd	569-0105-682
R 301	4.7k ohm $\pm 5\%$ 1/8W smd	569-0105-472
R 302	620 ohm $\pm 5\%$ 1/8W smd	569-0105-621
R 303	100k ohm $\pm 5\%$ 1/8W smd	569-0105-104
R 304	10k ohm $\pm 5\%$ 1/8W smd	569-0105-103
R 305	390k ohm $\pm 5\%$ 1/8W smd	569-0105-394
R 306	180k ohm $\pm 5\%$ 1/8W smd	569-0105-184
R 307	5.6k ohm $\pm 5\%$ 1/8W smd	569-0105-562

Ref No	Description	Part No.
R 308	100k ohm $\pm 5\%$ 1/8W smd (early versions)	569-0105-104
	150k ohm $\pm 5\%$ 1/8W smd (later versions)	569-0105-154
R 310	150k ohm $\pm 5\%$ 1/8W smd	569-0105-154
R 311	20k ohm $\pm 5\%$ 1/8W smd	569-0105-203
R 312	47k ohm $\pm 5\%$ 1/8W smd	569-0105-473
R 313	47k ohm $\pm 5\%$ 1/8W smd	569-0105-473
R 314	100k ohm $\pm 5\%$ 1/8W smd	569-0105-104
R 315	100k ohm $\pm 5\%$ 1/8W smd	569-0105-104
R 316	47k ohm $\pm 5\%$ 1/8W smd	569-0105-473
R 317	27k ohm $\pm 5\%$ 1/8W smd	569-0105-273
R 318	Thermistor, 10k ohm $\pm 5\%$	569-3013-007
R 319	330k ohm $\pm 5\%$ 1/8W smd	569-0105-334
R 320	62k ohm $\pm 5\%$ 1/8W smd	569-0105-623
R 321	470 ohm $\pm 5\%$ 1/8W smd	569-0105-471
R 322	10k ohm $\pm 5\%$ 1/8W smd	569-0105-103
R 323	62k ohm $\pm 5\%$ 1/8W smd	569-0105-623
R 324	33k ohm $\pm 5\%$ 1/8W smd	569-0105-333
R 325	5.6k ohm $\pm 5\%$ 1/8W smd	569-0105-562
R 326	33k ohm $\pm 5\%$ 1/8W smd	569-0105-333
R 327	33k ohm $\pm 5\%$ 1/8W smd	569-0105-333
R 328	62k ohm $\pm 5\%$ 1/8W smd	569-0105-623
R 329	33k ohm $\pm 5\%$ 1/8W smd	569-0105-333
R 330	62k ohm $\pm 5\%$ 1/8W smd	569-0105-623
R 331	33k ohm $\pm 5\%$ 1/8W smd	569-0105-333
R 332	47k ohm $\pm 5\%$ 1/8W smd	569-0105-473
R 333	62k ohm $\pm 5\%$ 1/8W smd	569-0105-623
R 334	390k ohm $\pm 5\%$ 1/8W smd	569-0105-394
R 335	33k ohm $\pm 5\%$ 1/8W smd	569-0105-333
R 336	62k ohm $\pm 5\%$ 1/8W smd	569-0105-623
R 337	33k ohm $\pm 5\%$ 1/8W smd	569-0105-333
R 338	62k ohm $\pm 5\%$ 1/8W smd	569-0105-623
R 339	10k ohm $\pm 5\%$ 1/8W smd	569-0105-103
R 340	47k ohm $\pm 5\%$ 1/8W smd	569-0105-473
R 341	47k ohm $\pm 5\%$ 1/8W smd	569-0105-473
R 342	33k ohm $\pm 5\%$ 1/8W smd	569-0105-333
R 343	27k ohm $\pm 5\%$ 1/8W smd	569-0105-273
R 344	560k ohm $\pm 5\%$ 1/8W smd	569-0105-564
R 345	62k ohm $\pm 5\%$ 1/8W smd	569-0105-623
R 346	62k ohm $\pm 5\%$ 1/8W smd	569-0105-623
R 347	10k ohm $\pm 5\%$ 1/8W smd	569-0105-103
R 348	150k ohm $\pm 5\%$ 1/8W smd	569-0105-154
R 349	1.5k ohm $\pm 5\%$ 1/8W smd	569-0105-152
R 350	5.6k ohm $\pm 5\%$ 1/8W smd	569-0105-562

Ref No	Description	Part No.
R 351	1.0k ohm $\pm$ 5% 1/8W smd	569-0105-102
R 352	820k ohm $\pm$ 5% 1/8W smd	569-0105-824
R 353	18k ohm $\pm$ 5% 1/8W smd	569-0105-183
R 354	Zero ohm smd jumper	569-0115-001
R 355	100k ohm $\pm$ 5% 1/8W smd	569-0105-104
R 356	180k ohm $\pm$ 5% 1/8W smd	569-0105-184
R 357	Zero ohm smd jumper	569-0115-001
R 358	4.7k ohm $\pm$ 5% 1/8W smd	569-0105-472
R 359	4.7k ohm $\pm$ 5% 1/8W smd	569-0105-472
R 360	470 ohm $\pm$ 5% 1/8W smd	569-0105-471
R 362	Zero ohm smd jumper	560-0105-001
R 363	Zero ohm smd jumper	560-0105-001
R 364	Zero ohm smd jumper	560-0105-001
R 365	470k ohm $\pm$ 5% 1/8W smd	569-0105-474
R 366	Zero ohm smd jumper	560-0105-001
R 367	470k ohm $\pm$ 5% 1/8W smd	569-0105-474
R 368	Zero ohm smd jumper	560-0105-001
R 369	5.6k ohm $\pm$ 5% 1/8W smd	569-0105-562
R 370	470 ohm $\pm$ 5% 1/8W smd	569-0105-471
R 371	39k ohm $\pm$ 5% 1/8W smd	569-0105-393
R 372	82k ohm $\pm$ 5% cer smd	569-0105-823
R 373	3.3k ohm $\pm$ 5% 1/8W smd	569-0105-332
R 374	68k ohm $\pm$ 5% cer smd	569-0105-683
R 375	150k ohm $\pm$ 5% 1/8W smd	569-0105-154
R 376	Zero ohm smd jumper	560-0105-001
R 377	4.7k ohm $\pm$ 5% 1/8W smd	569-0105-472
R 378	470 ohm $\pm$ 5% 1/8W smd	569-0105-471
R 379	6.8k ohm $\pm$ 5% 1/8W smd	569-0105-682
R 380	1.0k ohm $\pm$ 5% 1/8W smd	569-0105-102
R 381	1.0k ohm $\pm$ 5% 1/8W smd	569-0105-102
R 382	4.7k ohm $\pm$ 5% 1/8W smd	569-0105-472
R 383	Zero ohm smd jumper	569-0115-001
R 384	4.7k ohm $\pm$ 5% 1/8W smd	569-0105-472
R 385	4.7k ohm $\pm$ 5% 1/8W smd	569-0105-472
R 386	27k ohm $\pm$ 5% 1/8W smd	569-0105-273
R 387	47k ohm $\pm$ 5% 1/8W smd	569-0105-473
R 388	47k ohm $\pm$ 5% 1/8W smd	569-0105-473
R 389	82k ohm $\pm$ 5% cer smd	569-0105-823
R 390	100k ohm $\pm$ 5% 1/8W smd	569-0105-104
R 391	100k ohm $\pm$ 5% 1/8W smd	569-0105-104
R 392	330k ohm $\pm$ 5% 1/8W smd	569-0105-334
R 393	330k ohm $\pm$ 5% 1/8W smd	569-0105-334
R 394	10k ohm $\pm$ 5% 1/8W smd	569-0105-103
R 395	27k ohm $\pm$ 5% 1/8W smd	569-0105-273
R 397	10k ohm $\pm$ 5% 1/8W smd	569-0105-103

Ref No	Description	Part No.
R 399	Zero ohm smd jumper	569-0115-001
R 400	20k ohm $\pm$ 5% 1/8W smd	569-0105-203
R 401	620 ohm $\pm$ 5% 1/8W smd	569-0105-621
R 402	330k ohm $\pm$ 5% 1/8W smd	569-0105-334
R 403	20k ohm $\pm$ 5% 1/8W smd	569-0105-203
R 404	120k ohm $\pm$ 5% 1/8W smd	569-0105-124
R 405	10k ohm $\pm$ 5% 1/8W smd	569-0105-103
R 406	620 ohm $\pm$ 5% 1/8W smd	569-0105-621
R 407	10k ohm $\pm$ 5% 1/8W smd	569-0105-103
R 408	150k ohm $\pm$ 5% 1/8W smd	569-0105-154
R 409	10k ohm $\pm$ 5% 1/8W smd	569-0105-103
R 410	6.8k ohm $\pm$ 5% 1/8W smd	569-0105-682
R 411	22k ohm $\pm$ 5% 1/8W smd	569-0105-223
R 412	1.0k ohm $\pm$ 5% 1/8W smd	569-0105-102
R 413	1.0k ohm $\pm$ 5% 1/8W smd	569-0105-102
R 414	4.7k ohm $\pm$ 5% 1/8W smd	569-0105-472
R 415	10k ohm $\pm$ 5% 1/8W smd	569-0105-103
R 416	10k ohm $\pm$ 5% 1/8W smd	569-0105-103
R 417	27k ohm $\pm$ 5% 1/8W smd	569-0105-273
R 418	10k ohm $\pm$ 5% 1/8W smd	569-0105-103
R 419	10k ohm $\pm$ 5% 1/8W smd	569-0105-103
R 420	10k ohm $\pm$ 5% 1/8W smd	569-0105-103
R 421	10k ohm $\pm$ 5% 1/8W smd	569-0105-103
R 422	1.0k ohm $\pm$ 5% 1/8W smd	569-0105-102
R 423	4.7k ohm $\pm$ 5% 1/8W smd	569-0105-472
R 424	1.0k ohm $\pm$ 5% 1/8W smd	569-0105-102
R 425	4.7k ohm $\pm$ 5% 1/8W smd	569-0105-472
R 426	7.5k ohm $\pm$ 5% 1/8W smd	569-0105-752
R 427	820k ohm $\pm$ 5% 1/8W smd	569-0105-824
R 428	10k ohm $\pm$ 5% 1/8W smd	569-0105-103
R 429	100k ohm $\pm$ 5% 1/8W smd	569-0105-104
R 430	10k ohm $\pm$ 5% 1/8W smd	569-0105-103
R 431	4.7k ohm $\pm$ 5% 1/8W smd	569-0105-472
R 432	10k ohm $\pm$ 5% 1/8W smd	569-0105-103
R 433	4.7k ohm $\pm$ 5% 1/8W smd	569-0105-472
R 434	10k ohm $\pm$ 5% 1/8W smd	569-0105-103
R 435	4.7k ohm $\pm$ 5% 1/8W smd	569-0105-472
R 436	10k ohm $\pm$ 5% 1/8W smd	569-0105-103
R 437	4.7k ohm $\pm$ 5% 1/8W smd	569-0105-472
R 438	10k ohm $\pm$ 5% 1/8W smd	569-0105-103
R 439	33k ohm $\pm$ 5% 1/8W smd	569-0105-333
R 440	10k ohm $\pm$ 5% 1/8W smd	569-0105-103
R 441	4.7k ohm $\pm$ 5% 1/8W smd	569-0105-472
R 442	10k ohm $\pm$ 5% 1/8W smd	569-0105-103
R 443	820k ohm $\pm$ 5% 1/8W smd	569-0105-824

Ref No	Description	Part No.
RT 301	10k ohm thermistor	569-3013-007
U 100	Low volt sensor MC33164D	544-2003-074
U 101	Microcomputer, MC68HC11	544-5001-018
U 102	4k x 8 bit serial EEPROM X25320	544-5001-416
U 103	OR, 2-input quad 74HC32	544-3766-032
U 104	NAND, 2-input quad 74HC00	544-3766-000
U 105	Regulator, 5V .5A 78M05	544-2003-079
U 106	Demux, 10 of 8 74HC138	544-3766-138
U 107	8k x 8 CMOS static RAM AT3864	544-5002-115
U 108	EPROM, Flash 128k x 8 AT29C010	544-5001-211
U 109	Mux, 2-input quad 74HC157	544-3766-157
U 110	D-flip flop octal 74HC574	544-3766-574
U 111	D-flip flop octal 74HC574	544-3766-574
U 112	D-flip flop octal 74HC574	544-3766-574
U 113	2-input NAND, quad 74HC00	544-3766-000
U 300	Op amp, quad MC3303	544-2020-008
U 301	Op amp, quad MC3303	544-2020-008
U 302	Op amp, quad MC3303	544-2020-008
U 303	Op amp, quad MC3303	544-2020-008
U 304	Op amp, dual 2904	544-2019-004
U 305	Shift reg. 8-stage MC4094	544-3016-094
U 306	Audio amp, 3W w/vol control	544-2006-025
U 307	Bilateral switch, quad MC4066	544-3016-066
U 308	Bilateral switch, quad MC4066	544-3016-066
U 309	Shift register, 8-stage 4094	544-3016-094
Y 100	9.8304 MHz crystal	521-0009-830

Ref No	Description	Part No.
<b>9800-SERIES RADIO MOUNTING KIT PART NO. 023-9800-030</b>		
HW001	Screw, No. 10 self drilling (4)	575-9077-545
MP001	Tri knob (2)	547-0016-008
<b>9800-SERIES REMOTE MOUNTING KIT PART NO. 023-9800-040</b>		
HW001	Screw, No. 10 self drilling (4)	575-9077-545
HW002	Flat washer, vulcanized (2)	596-6400-030
MP004	Mounting bracket, rem ctrl unit	017-2227-057
MP001	Tri knob (2)	547-0016-008

Ref No	Description	Part No.
<b>DC POWER CABLE AND HARDWARE KIT PART NO. 023-9800-410 (10 Ft) PART NO. 023-9800-422 (22 Ft)</b>		
A 001	Mic clip ground wire assembly	023-7171-911
EP101	Power connector contact (2)	515-9033-006
EP104	Ring term, 3/8" 10-12 AWG (1)	586-0001-019
EP105	Ring term, 3/4" 10-12 AWG (1)	586-0001-036
F 201	Fuse kit, 15A and 7A	534-0003-100
FH101	Fuseholder assembly includes: Body Knob w/washer Contact, 14-16 AWG (2) Spring	534-1004-031 534-1004-032 534-1004-037 534-1004-035
HW201	Screw, 4-24 x 5/16" sheet metal (3)	575-3604-010
MP201	HD mic clip	023-3514-001
P 101	Power connector housing, dual	515-9033-012
W 101	Wire, 12 AWG stranded red	597-7021-202
W 103	Wire, 12 AWG stranded blue	597-7021-206
<b>ACCESSORY WIRE KIT PART NO. 023-9750-011</b>		
F 001	Fuse, 1A 250V FB AGC	534-0003-020
FH001	Fuseholder includes: Fuse contact, 16-20 AWG (2) Body Knob Spring	586-9004-001 534-1004-031 534-1004-032 534-1004-035
HW001	Crimp pin contact (7)	515-1501-055
P 100	Receptacle housing, 8-pin (2)	515-1501-050
<b>AMPLIFIED DYNAMIC MICROPHONE PART NO. 250-0740-300</b>		
C 001	3.3 $\mu$ F 16V tantalum chip	510-2625-339
C 002	220 pF $\pm$ 5% NPO 50V cer chip	510-3602-221
EP001	Contact .038" diameter	586-9008-100
EP002	Mic cord w/mod connector	597-2002-113
EP004	Terminal (on hanger)	022-0069-011
HW001	Screw 4-20 x 3/8	575-5604-012
HW004	Screw 2-56 x 3/8	575-1602-012
MK001	Dynamic mic cartridge	589-1011-003
MP001	Case front black	032-0426-100
MP002	Case back black	032-0427-100

Ref No	Description	Part No.
MP003	Actuator black	032-0428-050
MP004	Cartridge gasket	032-0429-075
MP005	Blast filter	018-1033-002
MP006	Switch bracket	017-1885-030
MP007	Hanger button	013-1216-005
MP008	Crimp retainer	017-2222-005
MP009	Rubber bumper	018-0798-009
MP010	Backing plate	015-0876-026
MP011	Strain relief, mic cord	032-0429-085
MP012	Shim support, rubber bumper	017-2222-007
MP020	Foam support	018-0798-012
NP001	Nameplate	559-0039-026
PC001	PC board, amplifier	035-0441-020
Q 001	NPN amplifier SOT-23	576-0003-658
R 001	51k ohm $\pm 5\%$ 1/8W chip	569-0115-513
R 002	18 ohm $\pm 5\%$ 1/8W chip	569-0115-180
S 001	Leaf switch SPST	583-1004-031
<b>15 WATT, 4.7-OHM SPEAKER (BLACK)</b>		
<b>PART NO. 250-0151-010</b>		
HW000	Screw, self-drilling	575-9077-543
HW001	Strain relief (in case back)	574-0003-008
HW003	Screw, 4-20 x 1/2 pan head	575-5604-016
HW005	Foam gasket	018-1126-001
HW006	Retaining washer	596-9210-012
LS001	Speaker, 5" 15W 4.7 ohm	589-1016-004
MP000	Mounting bracket (black)	032-0760-004
MP000	Tri knob 10-32	547-0016-004
MP001	Case front (black)	032-0758-004
MP002	Case back (black)	032-0759-004
NP001	Overlay, speaker front	559-0072-010
P 001	Miniature phone plug	515-0020-003
W 001	Cable, 2-cond 18 AWG	597-2006-100

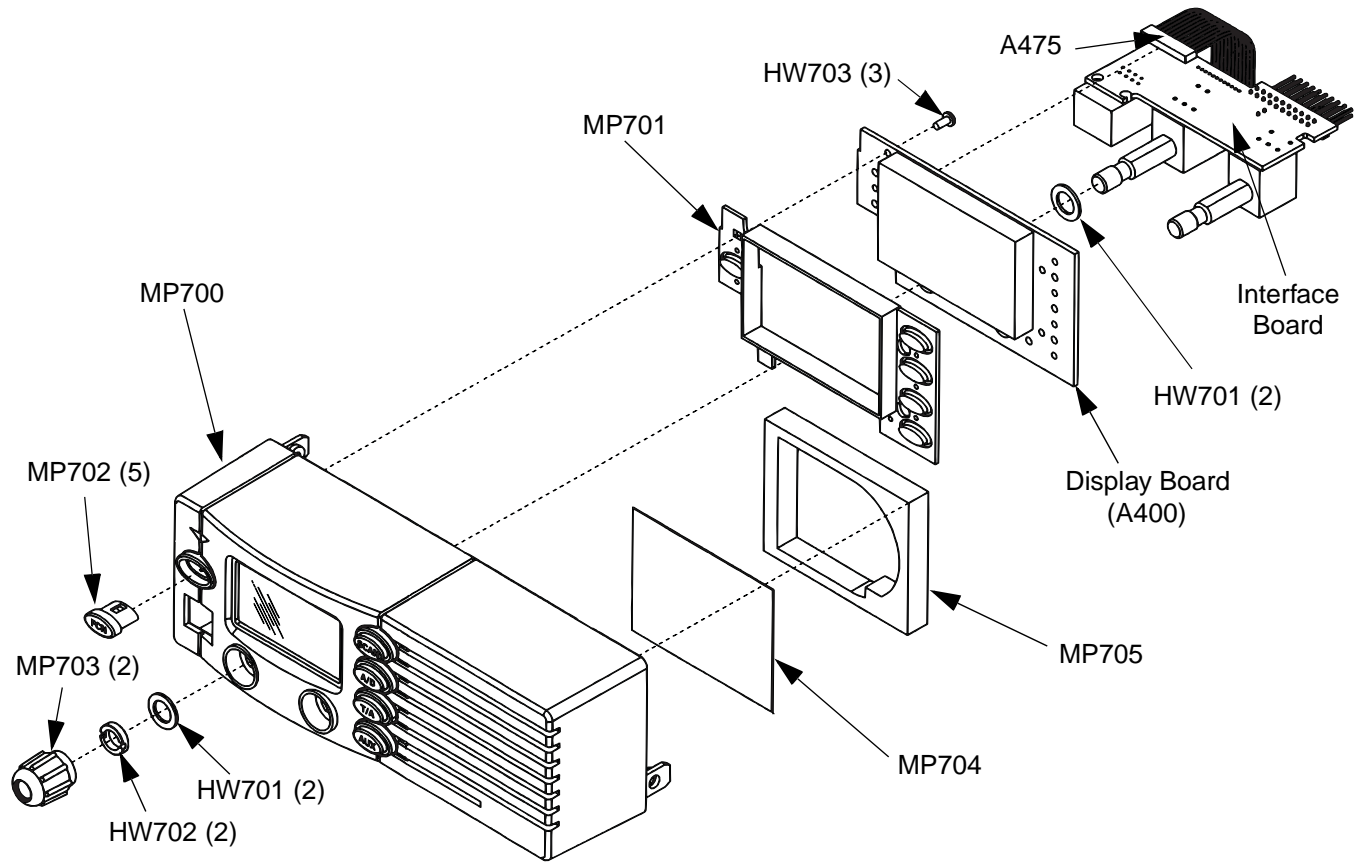

**HIGH TIER FRONT PANEL EXPLODED VIEW**

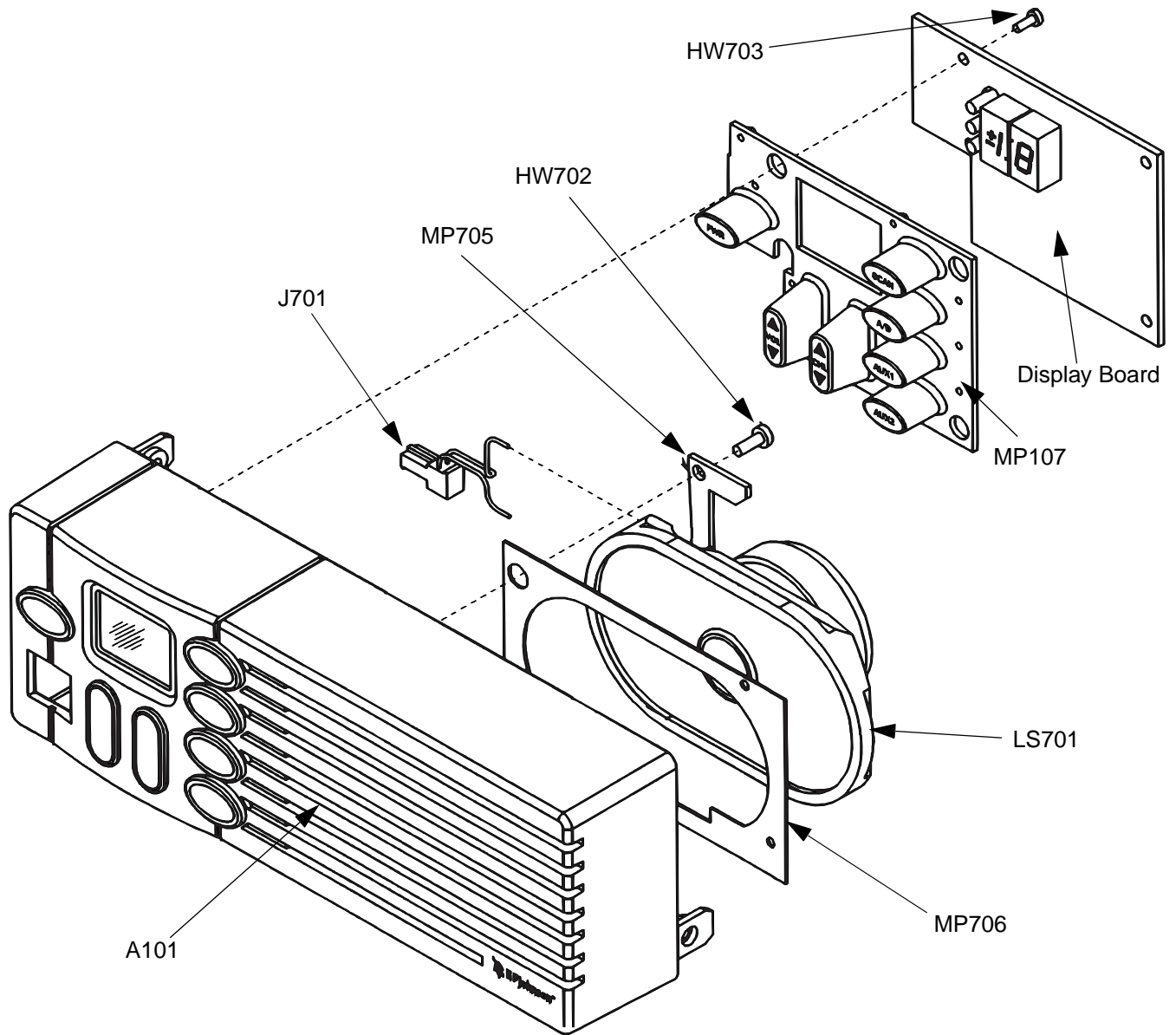

LOW TIER FRONT PANEL EXPLODED VIEW



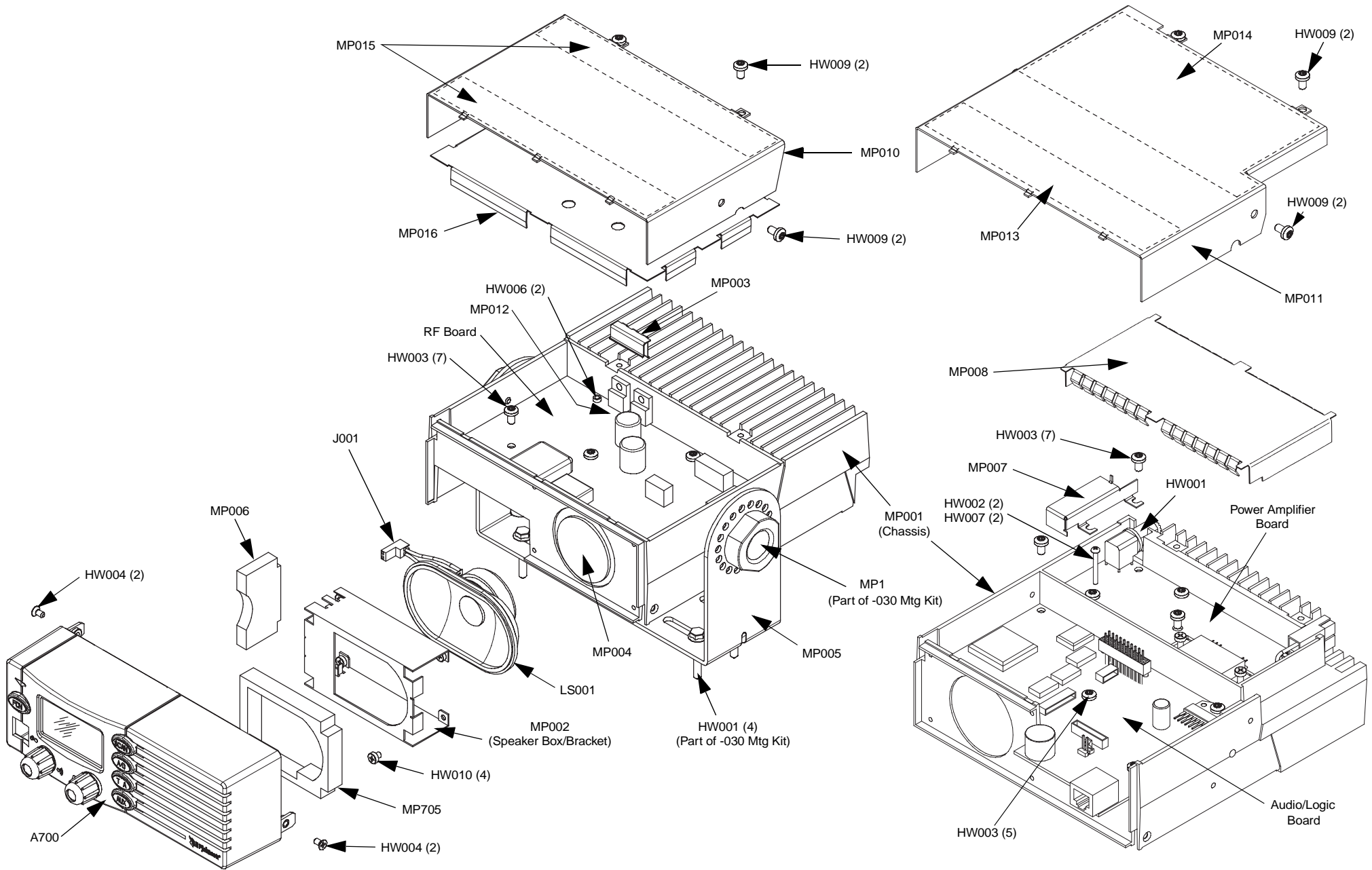

**FRONT AND TOP MECHANICAL PARTS**

**BOTTOM MECHANICAL PARTS**

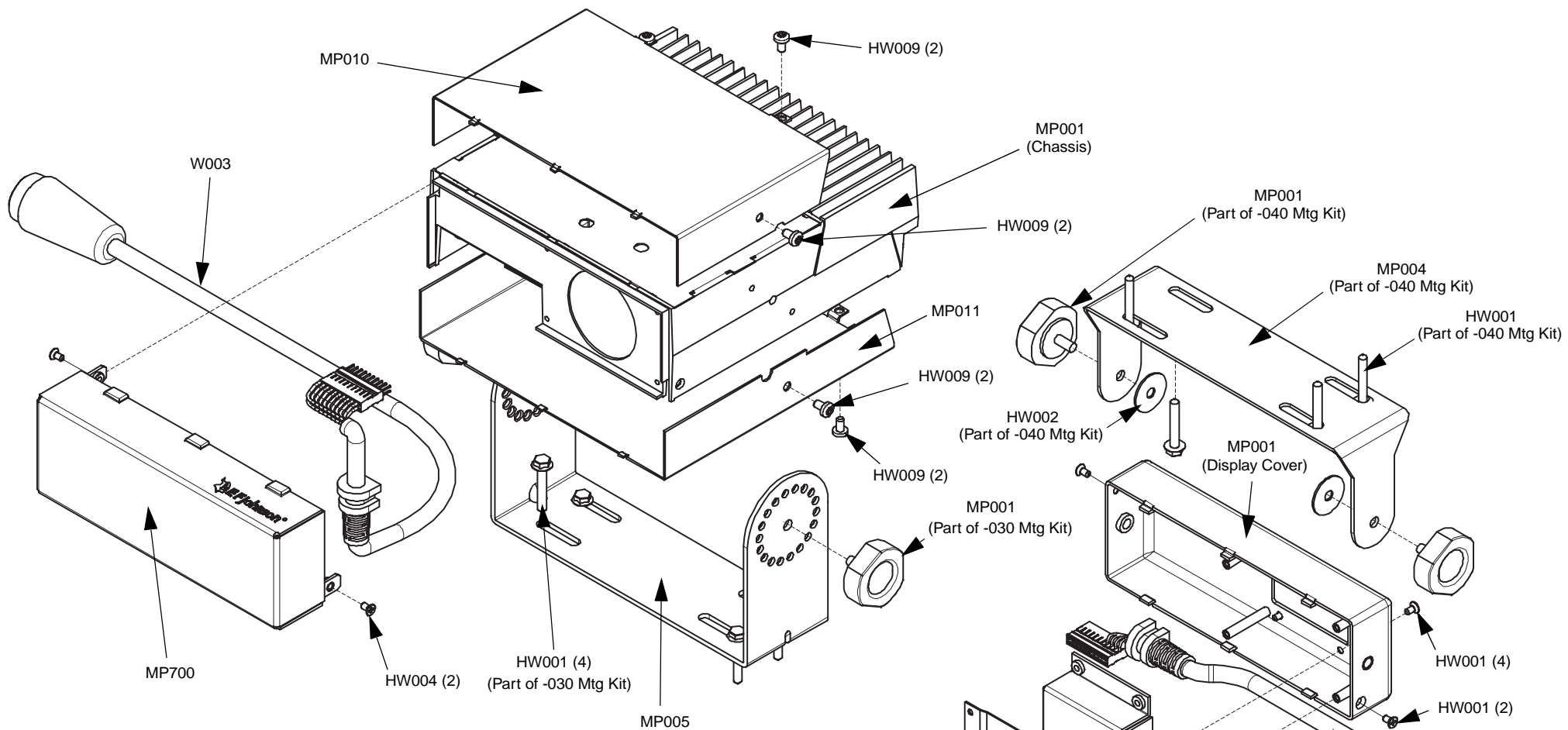

**REMOTE TRANSCEIVER MECHANICAL PARTS**

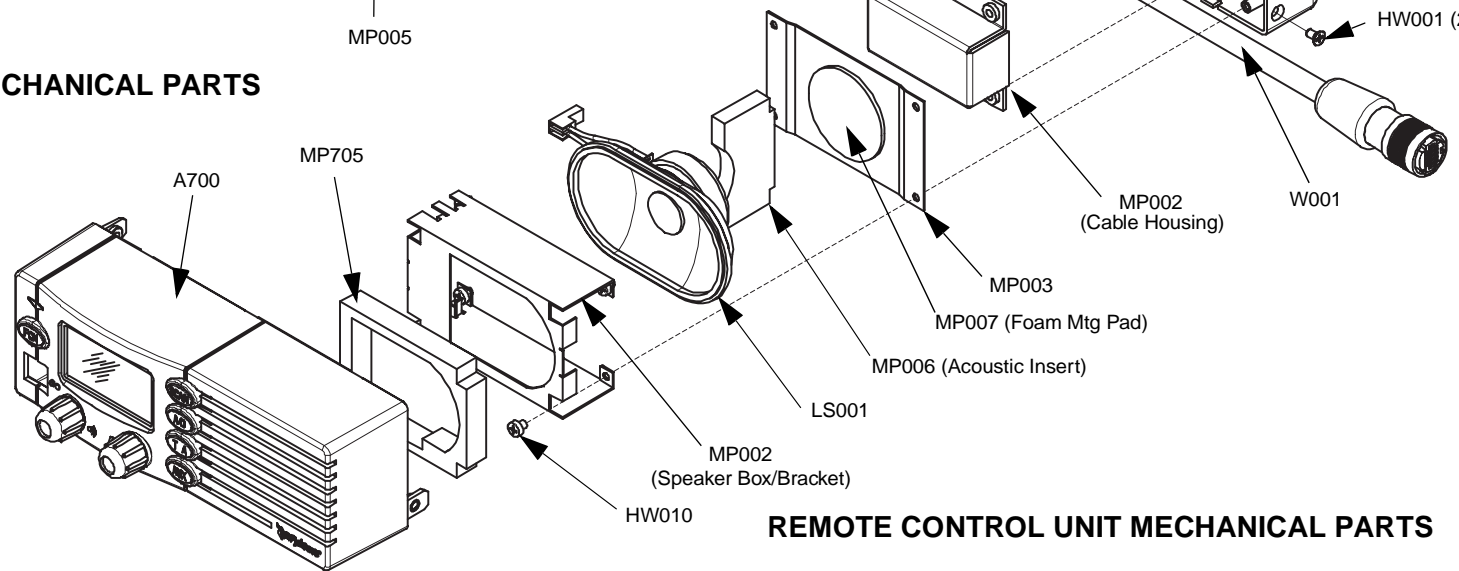

**REMOTE CONTROL UNIT MECHANICAL PARTS**

SECTION 9 SCHEMATIC DIAGRAMS AND COMPONENT LAYOUTS

TRANSISTOR AND DIODE BASING DIAGRAMS

TRANSISTORS		
Part Number	Basing Diagram	Identification
576-0001-300	1	1R
576-0002-057	2	-
576-0002-070	3	-
576-0003-604	4	3604
576-0003-612	1	2T
576-0003-616	1	26
576-0003-618	5	10
576-0003-634	1	3B
576-0003-636	1	R25
576-0003-651	1	24
576-0003-657	1	2A
576-0003-658	1	1A
576-0004-098	4	-
576-0004-401	6	-
576-0004-402	7	-
576-0004-817	8	-
576-0006-027	9	-
576-0006-114	10	-
576-0006-120	11	-
576-0006-234	12	MO
576-0006-450	11	-
576-0007-013	2	-

DIODES		
Part Number	Basing Diagram	Identification
523-1504-001	-	4D
523-1504-002	-	5A
523-1504-016	-	5F
523-1504-023	-	A7
523-1504-024	-	A1
523-1504-032	-	-
523-1504-035	-	AS
523-2016-120	-	Y2
523-2016-180	-	Y6
523-2016-339	-	W6 or Z14
523-2016-519	-	Z2
523-2016-569	-	Z3

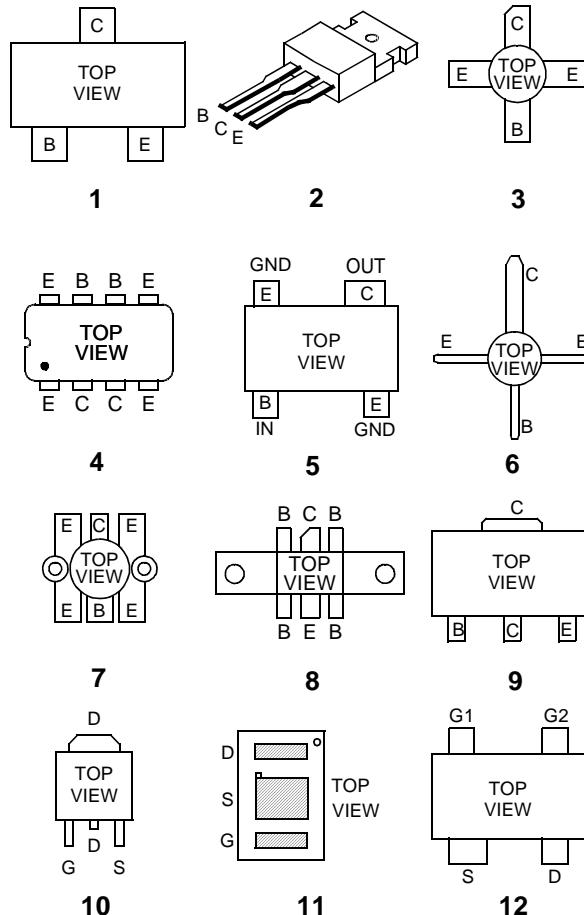

Number on Schematic —

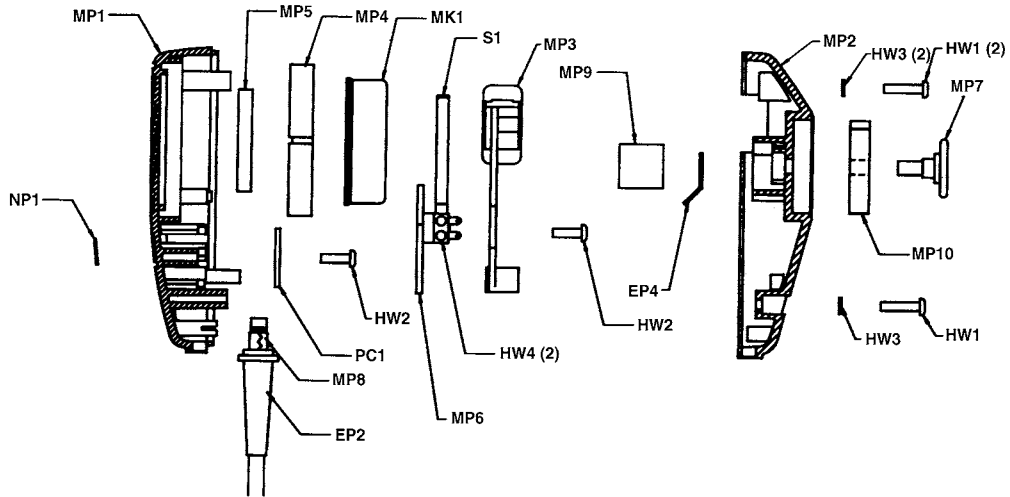
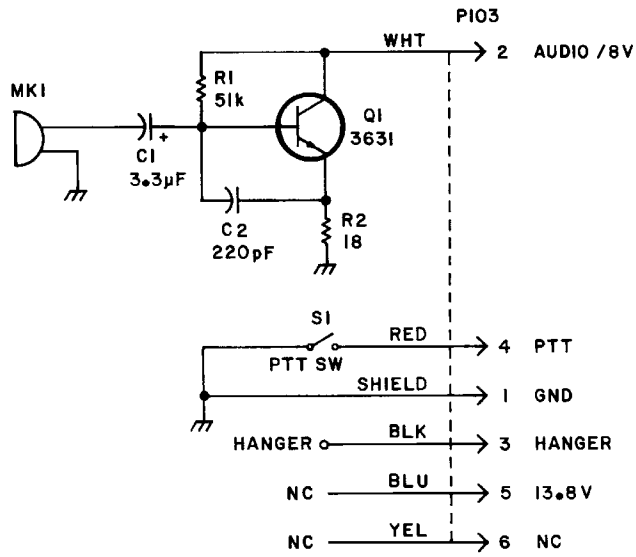

**AMPLIFIED DYNAMIC MICROPHONE SCHEMATIC AND MECHANICAL PARTS**  
**Part No. 250-0740-300**

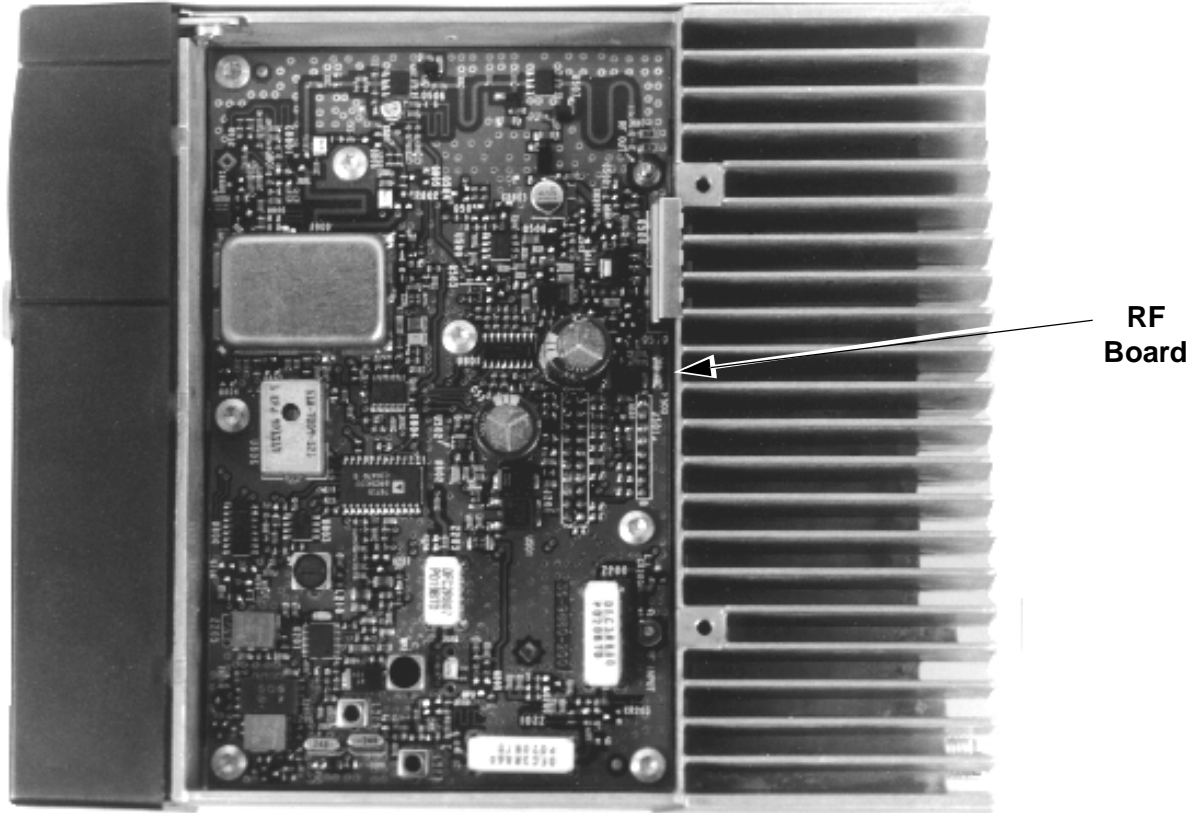

**TRANSCEIVER TOP PHOTO (800 MHZ SHOWN)**

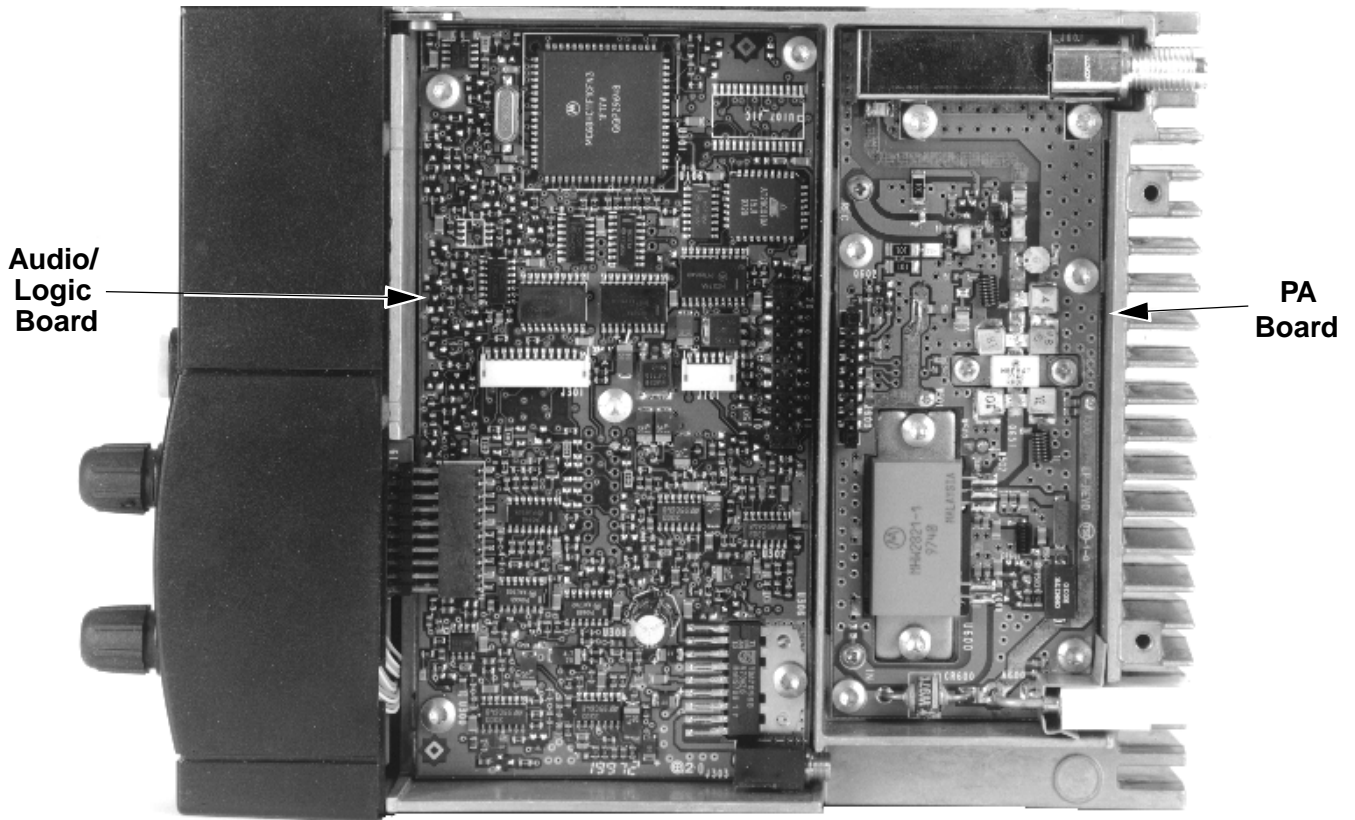

**TRANSCEIVER BOTTOM PHOTO (800 MHZ, 30W SHOWN)**

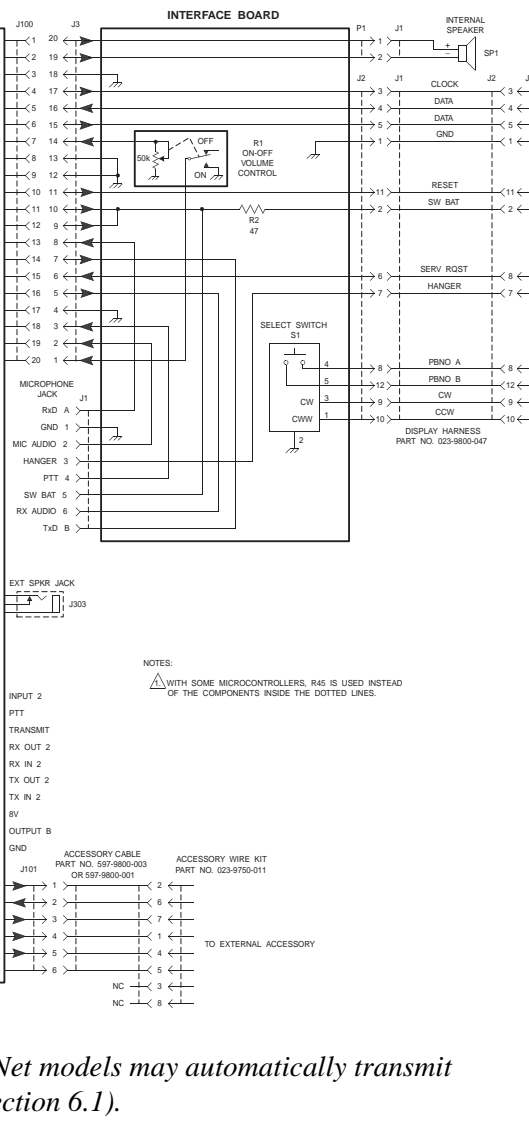
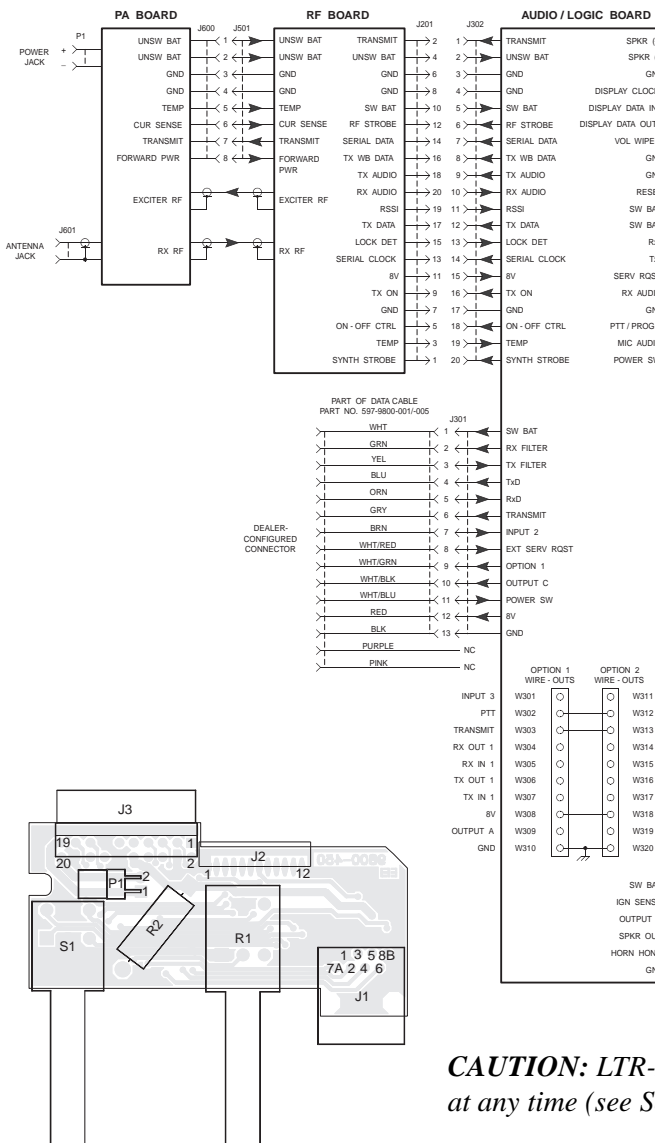

**CAUTION:** LTR-Net models may automatically transmit at any time (see Section 6.1).

HIGH TIER INTERFACE BOARD LAYOUT

HIGH TIER INTERCONNECT SCHEMATIC



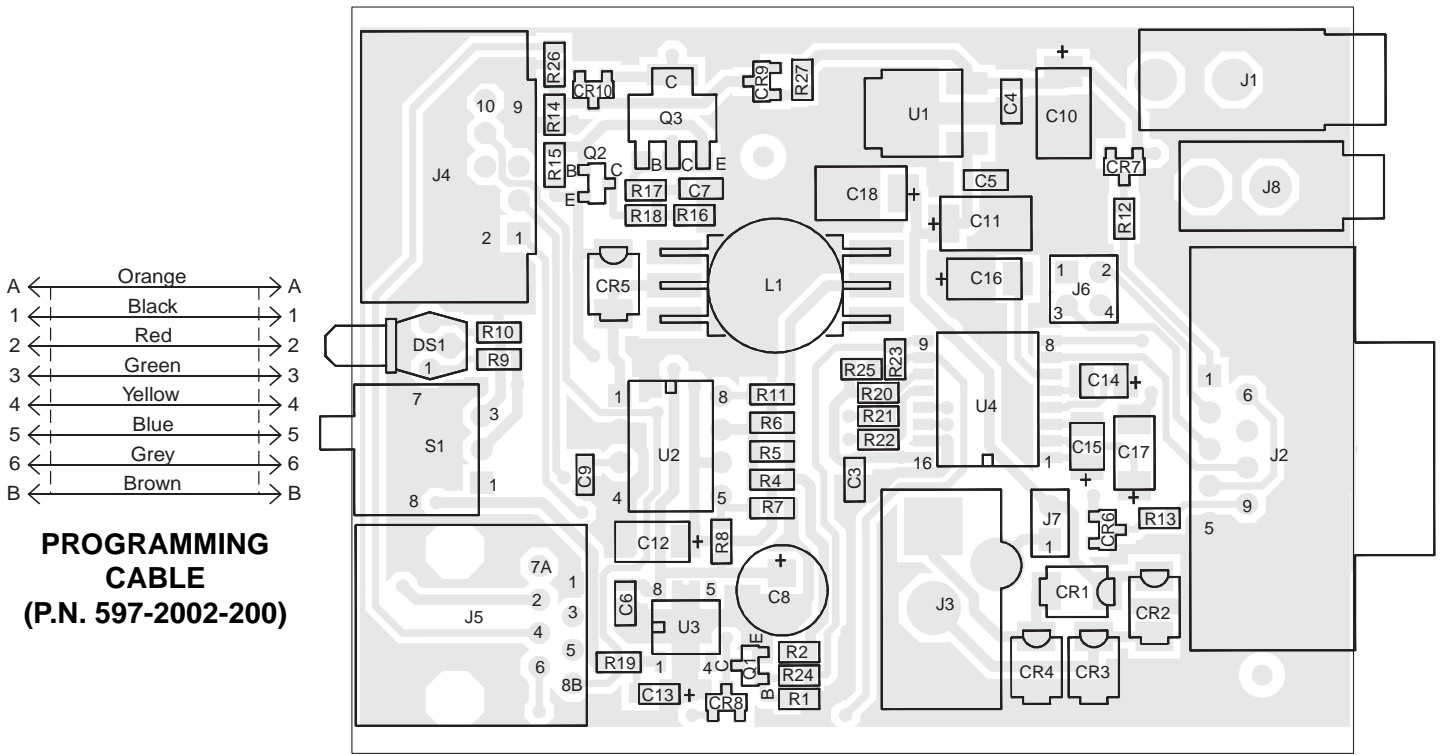

**RPI (P.N. 023-9800-000) BOARD LAYOUT**

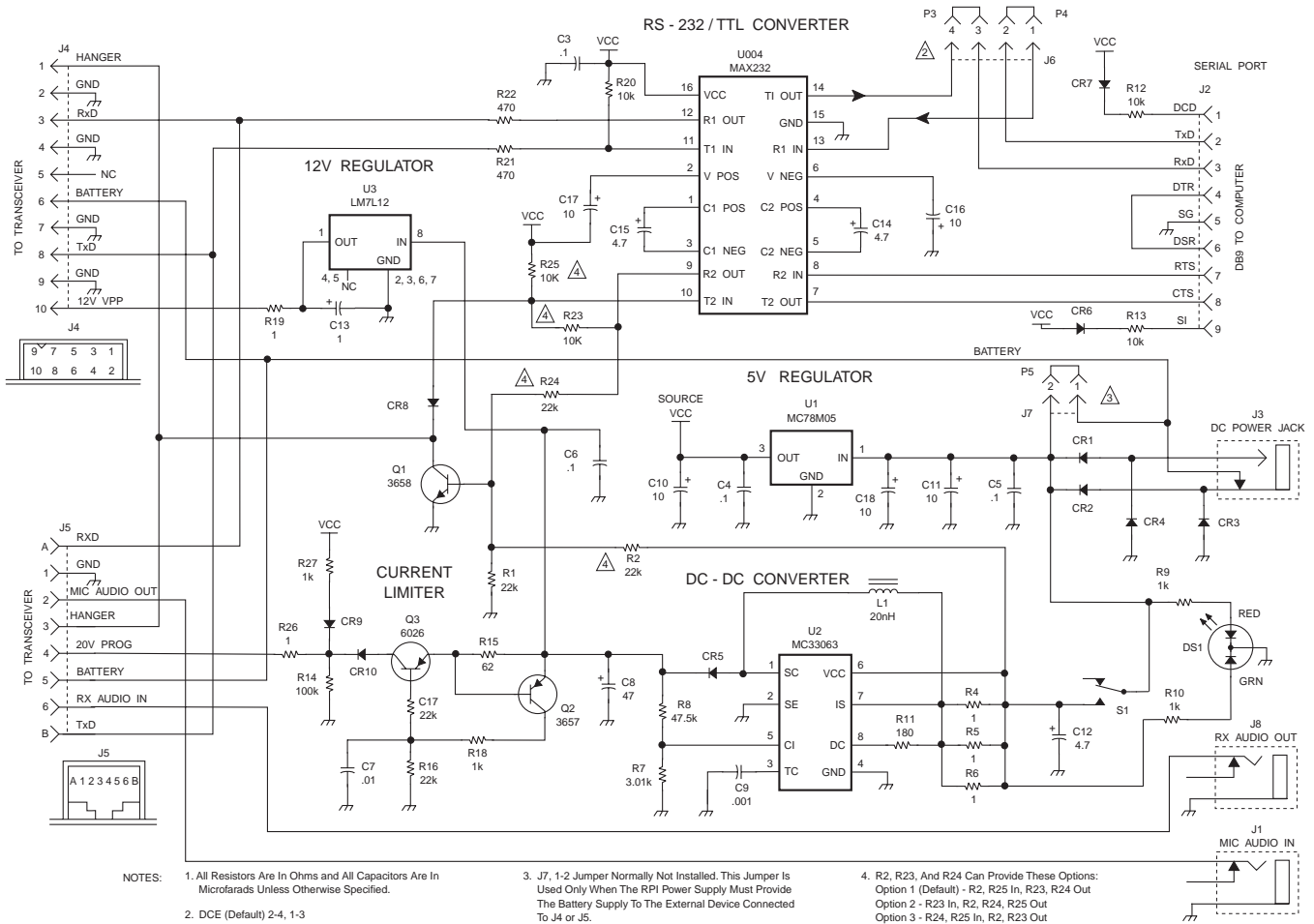

- NOTES:
- All Resistors Are In Ohms and All Capacitors Are In Microfarads Unless Otherwise Specified.
  - DCE (Default) 2-4, 1-3 DTE - 1-2, 3-4
  - J7, 1-2 Jumper Normally Not Installed. This Jumper Is Used Only When The RPI Power Supply Must Provide The Battery Supply To The External Device Connected To J4 or J5.
  - R2, R23, And R24 Can Provide These Options:  
 Option 1 (Default) - R2, R25 In, R23, R24 Out  
 Option 2 - R23 In, R2, R24, R25 Out  
 Option 3 - R24, R25 In, R2, R23 Out

**RPI (P.N. 023-9800-000) SCHEMATIC**



## RF BOARD COMPONENT LOCATOR GUIDE (UHF)

The following guide can be used to locate components on the 430-470 and 470-512 MHz RF board layouts on pages 9-16 and 9-21. Refer to the grid around the board to determine the approximate location of a component.

*NOTE: When the location of a component is different on the board unrevised 430-470 MHz board, the location on the unrevised board is listed first and the location on the revised 430-512 MHz board is listed second.*

Comp.	Location	Comp.	Location	Comp.	Location	Comp.	Location
A 900	C2	C 241	B5	C 290	C4	C 523	A1/C1
C 201	A4	C 242	B5	C 291	C5	C 524	A1/B1
C 202	A5	C 243	B5	C 292	B4	C 525	C1/B1
C 203	A4	C 244	B5	C 293	C5	C 526	C1
C 204	A4	C 245	B5	C 294	B5	C 527	C1
C 205	A4	C 246	B5	C 295	C5	C 528	C1/B1
C 206	A4	C 247	B5	C 296	C5	C 529	C1/B1
C 207	A4	C 248	B5	C 297	C5	C 530	C1
C 208	A4	C 249	B4	C 298	C5	C 531	C1
C 209	A4	C 251	B5	C 299	C4	C 532	C1/A1
C 210	A4	C 252	B5	C 300	C4	C 533	C1/A1
C 211	A4	C 253	B5	C 301	C4	C 534	B1/A1
C 212	A4	C 255	B4	C 302	C4	C 535	A1
C 213	A4	C 256	B4	C 303	B4	C 536	B1
C 214	A4	C 258	B4	C 304	B5	C 537	C1/A1
C 215	A4	C 259	B4	C 305	A3	C 538	C1/B1
C 216	A4	C 260	B4	C 306	A3	C 539	B1
C 217	A4	C 261	B4	C 307	B5	C 540	B1/C1
C 218	A4	C 262	B4	C 500	B2	C 541	B2/C1
C 219	A4	C 263	B4	C 501	A2/B2	C 542	B1/C1
C 220	A5	C 264	B4	C 502	B2	C 543	B1
C 221	A5	C 266	B5	C 503	A2	C 544	B1
C 222	A5	C 268	B5	C 504	A2	C 545	A1
C 223	A5	C 269	C5	C 505	A2	C 546	A1
C 224	A5	C 270	C5	C 506	A3	C 547	A1
C 225	A5	C 271	C5	C 507	A4	C 548	A3A1
C 226	A5	C 272	C5	C 508	A4	C 549	A3/A1
C 227	A5	C 274	C5	C 509	A3	C 550	A3/C1
C 228	A5	C 275	C4	C 510	A4	C 551	A3/C1
C 229	B5	C 276	C4	C 511	A3/B2	C 552	B3/C1
C 230	B5	C 277	C4	C 512	A1/A4	C 553	B3/C1
C 231	A5	C 278	C5	C 513	A2/A3	C 554	A3/B1
C 232	A5	C 281	C5	C 514	B1/B2	C 555	A3/C1
C 233	A5	C 282	C5	C 515	A1/B2	C 556	B4/C1
C 234	B5/A5	C 283	B4	C 516	A1/C1	C 557	B4/C1
C 235	B5	C 284	C4	C 517	B1/B2	C 558	B4/B1
C 236	B5	C 285	B4	C 518	B1/C1	C 559	A4/B1
C 237	B5	C 286	C4	C 519	B1/A1	C 560	A3
C 238	B5	C 287	C4	C 520	C1/A1	C 561	B4/A3
C 239	B5	C 288	B4	C 521	C1	C 562	B3/A3
C 240	B5	C 289	C5	C 522	A1/C1	C 563	B3/A3

## UHF RF BOARD COMPONENT LOCATOR GUIDE (CONT'D)

Comp.	Location	Comp.	Location	Comp.	Location	Comp.	Location
C 564	B3	C 831	B2	J 501	A3	Q 506	C1
C 565	A2/B3	C 832	B3			Q 507	C1
C 566	B3/A3	C 833	B3	L 200	A4	Q 508	B1/A3
C 567	B1/A3	C 834	B2	L 201	B4	Q 509	A1/C1
C 568	A1/B4	C 835	B2	L 202	A5	Q 510	A2/C1
C 569	A1/B4	C 836	B2	L 203	A5	Q 511	A2/B1
C 570	C1/B4	C 837	B2	L 204	A5	Q 512	A2/A1
C 571	C1A3	C 838	B2	L 205	B5	Q 513	A2
C 572	B1/A3	C 839	B2	L 206	B5	Q 514	A2
C 573	B1/B4	C 840	B2	L 207	B5	Q 515	A2
C 574	B1/B3	C 841	B3	L 208	B5	Q 516	A2
C 575	B1/B3	C 842	C3	L 209	B4	Q 517	A3/A2
C 576	A1/B3	CR200	A5	L 210	B4	Q 800	C2
C 577	A1/A2	CR201	A4	L 211	B4	Q 801	C2
C 578	B1/B3	CR202	A4	L 213	B5		
C 579	B1/A1	CR203	B5	L 215	C5	R 200	A4
		CR204	A5	L 217	C4	R 201	A4
C 800	A3	CR205	B5	L 218	C4	R 202	A4
C 801	A3	CR206	B4	L 219	B4	R 203	A4
C 802	A3	CR207	C5	L 220	B5	R 204	A4
C 803	A4	CR208	C5	L 500	A1	R 205	A5
C 805	A3	CR209	C5	L 501	B1/C1	R 206	A5
C 807	C2	CR210	C5	L 502	C1	R 207	A5
C 808	C2	CR211	A3	L 503	C1	R 208	A5
C 809	C4	CR212	A2	L 504	C1	R 209	A5
C 810	A3	CR500	A2	L 505	C1	R 210	B5
C 811	C3	CR501	A2	L 506	C1/B1	R 211	A5
C 812	C3	CR502	A2	L 507	B1	R 212	B5
C 813	C1	CR503	B2	L 800	C2	R 213	B5
C 814	C2	CR504	A2	L 801	C2	R 214	B5
C 815	B3	CR505	A3	L 802	C3	R 215	B5
C 816	C3	CR506	A2			R 216	B5
C 817	C1	CR507	A2	Q 200	A5	R 217	B5
C 818	C2	CR800	C1	Q 201	A5	R 218	B5
C 819	C3	CR801	C1	Q 202	B5	R 219	B4
C 820	C4	CR802	B2	Q 203	B4	R 220	B4
C 821	B3			Q 204	B4	R 221	B4
C 822	C2	EP001	A2	Q 205	C4	R 222	B4
C 823	C3	EP002	B1	Q 206	C4	R 223	B4
C 824	C3	EP003	B1	Q 207	B4	R 224	B4
C 825	C4	EP500	B1	Q 500	A2	R 225	B4
C 826	C2/C1	EP501	A1	Q 501	A2	R 226	B4
C 827	C2			Q 502	A2	R 227	B4
C 828	C3	F 500	A3	Q 503	B2/A2	R 228	C5
C 829	C3			Q 504	C1/A2	R 229	C5
C 830	B3	J 201	A3	Q 505	C1/B2	R 231	C4

## UHF RF BOARD COMPONENT LOCATOR GUIDE (CONT'D)

Comp.	Location	Comp.	Location	Comp.	Location	Comp.	Location
R 232	C4	R 512	B2/A2	R 552	A2	R 834	C4
R 233	C5	R 513	A2/B2	R 553	A2	R 835	C3
R 234	C5	R 514	B2/A2	R 554	B1	R 836	C2
R 237	C5	R 515	C1/B2	R 555	B1	R 837	C2
R 238	C5	R 516	C1/A2	R 556	A3	R 838	B3
R 239	C5	R 517	C1/A2	R 557	A3	R 839	C2
R 240	C5	R 518	A1/B2	R 800	B2	R 840	C4
R 241	C5	R 519	B1/A2	R 801	A2	R 841	C4
R 242	C5	R 520	C1/B2	R 802	B2	R 842	C2
R 243	B4	R 521	C1	R 803	B2	R 843	C2
R 244	B4	R 522	B1/C1	R 804	A2	R 844	C1
R 245	C4	R 523	B1/C1	R 805	B2	R 845	B3
R 246	C4	R 524	B1/A3	R 806	B2	R 846	B3
R 247	C4	R 525	C1/A3	R 807	A2	R 847	C2
R 248	C4	R 526	C1/B2	R 808	B2	R 848	B3
R 249	B4	R 527	B1	R 809	B2	R 849	B2
R 250	B4	R 528	C1/B1	R 810	A2	R 850	C4
R 251	B4	R 529	C1	R 811	B3	R 851	B2
R 252	C5/B5	R 530	C1	R 812	A3	R 852	B2
R 253	C5	R 531	C1	R 813	B3	R 853	B2
R 254	C5	R 532	B1	R 814	B3	R 854	B2
R 255	C5	R 533	A3/C1	R 815	B3	R 855	B3
R 256	C4/B5	R 534	A3/B1	R 816	B3	R 856	B2
R 257	C4	R 535	A2/C1	R 817	C4		
R 258	C4	R 536	A2/C1	R 818	C3	U 201	C5
R 259	B4	R 537	A2/A1	R 819	C4	U 500	B2
R 260	A2	R 538	A2/A3	R 820	A3	U 501	B4
R 261	A2	R 539	B3	R 821	C4	U 502	B3
R 500	B2	R 540	B3/A2	R 822	A3	U 800	C4
R 501	A2/B2	R 541	A2	R 823	B3	U 801	B3
R 502	A2	R 542	A2	R 824	C4	U 802	B4
R 503	B2	R 543	B3/A2	R 825	C3	U 803	C4
R 504	A2	R 544	B2	R 826	C4	U 804	B3
R 505	B2/A2	R 545	A2	R 827	C2	U 806	C3
R 506	A2/B2	R 546	C1/B3	R 828	A3		
R 507	A2/B2	R 547	B3	R 829	B3	Z 202	C5
R 508	B2/A2	R 548	A2	R 830	C1	Z 204	C5
R 509	B2/A2	R 549	A2	R 831	C3	Z 205	C5
R 510	A2/B2	R 550	A2/B3	R 832	C2	Z 206	C5
R 511	A2	R 551	A2	R 833	C1		

## RF BOARD COMPONENT LOCATOR GUIDE (800/900 MHZ)

The following guide can be used to locate components on the 800 MHz RF board layout on page 9-28 and the 900 MHz RF board layout on page 9-29. Refer to the grid around the board to determine the approximate location of a component.

Comp.	Location	Comp.	Location	Comp.	Location	Comp.	Location
A 900	A2	C 287	B4	C 522	B1	C 809	A4
C 202	C4	C 288	B4	C 523	B1	C 810	C3
C 214	C5	C 289	A5	C 524	C1	C 811	A3
C 222	C5	C 290	B4	C 525	B1	C 812	A3
C 223	B5	C 291	A5	C 526	B1	C 813	A1
C 224	C5	C 292	B4	C 527	C1	C 814	A2
C 225	C5	C 293	A5	C 528	B1	C 815	B3
C 226	C5	C 294	B5	C 529	A1	C 816	B3
C 227	C5	C 295	A5	C 530	C1	C 817	A1
C 228	C5	C 296	A5	C 531	B1	C 818	A1
C 231	B5	C 297	A5	C 532	C1	C 819	B3
C 232	B5	C 298	A5	C 537	A1	C 820	A4
C 244	B5	C 299	A4	C 547	B2	C 821	B3
C 245	B5	C 300	A4	C 548	C3	C 822	A2
C 246	B5	C 301	A4	C 549	C3	C 823	A3
C 247	B5	C 302	A4	C 550	C3	C 824	A3
C 248	B5	C 303	B4	C 551	C3	C 825	A4
C 249	B5	C 304	B4	C 552	B3	C 826	A2
C 250	B5	C 305	C3	C 553	B3	C 827	A1
C 255	B4	C 306	C3	C 554	C3	C 828	A3
C 264	B5	C 500	B2	C 555	C3	C 829	A3
C 265	B5	C 501	C2	C 556	B4	C 830	B3
C 266	B5	C 502	B2	C 557	B4	C 831	B2
C 267	B5	C 503	C2	C 558	B4	C 832	B3
C 268	B5	C 504	C2	C 559	C3	C 833	B3
C 269	A5	C 505	C2	C 560	C3	C 834	B2
C 270	A5	C 506	C3	C 561	B4	C 835	B2
C 271	A5	C 507	C4	C 562	B3	C 836	B2
C 272	A5	C 508	C4	C 563	B3	C 837	B2
C 273	A5	C 509	C3	C 564	B3	C 838	B2
C 274	A5	C 510	C4	C 565	C2	C 839	B2
C 275	A4	C 511	C3	C 566	B3	C 840	B2
C 276	A4	C 512	C2	C 599	C2	C 841	A3
C 277	A4	C 513	C1	C 800	C3	C 842	A3
C 278	A5	C 514	C1	C 801	C3	C 843	A3
C 280	A5	C 515	A1	C 802	C3	C 844	A1
C 281	A5	C 516	B1	C 803	C4	C 845	A1
C 282	A5	C 517	B1	C 804	C3	C 846	B1
C 283	B4	C 518	B1	C 805	C3	C 847	B1
C 284	B4	C 519	B1	C 806	C3	C 848	A1
C 285	B4	C 520	B1	C 807	A1	C 849	A3
C 286	B4	C 521	B1	C 808	A1	C 850	A2

## 800/900 MHz RF BOARD COMPONENT LOCATOR GUIDE (CONT'D)

Comp.	Location	Comp.	Location	Comp.	Location	Comp.	Location
CR 200	C4	Q 205	A4	R 229	A5	R 518	B1
CR 203	C5	Q 206	A4	R 230	A5	R 519	B1
CR 207	A5	Q 207	B4	R 231	A4	R 520	B1
CR 208	A5	Q 500	C2	R 232	A4	R 521	B1
CR 209	A5	Q 501	C2	R 233	A5	R 522	B1
CR 210	A5	Q 502	C1	R 234	A5	R 523	B1
CR 500	C2	Q 503	B2	R 237	A5	R 524	C2
CR 501	C2	Q 504	B1	R 238	A5	R 525	C2
CR 502	C2	Q 505	B2	R 239	A5	R 526	C2
CR 503	B2	Q 506	B1	R 240	A5	R 527	C2
CR 504	C2	Q 507	C1	R 241	A5	R 528	B1
CR 505	C2	Q 508	C2	R 242	A5	R 529	C1
CR 506	C2	Q 509	C3	R 243	B4	R 530	C1
CR 800	A1	Q 510	C2	R 244	B4	R 531	C1
CR 801	A1	Q 511	C2	R 245	B4	R 533	C3
CR 802	B2	Q 512	C2	R 246	B4	R 534	C3
CR 803	B2	Q 513	C2	R 247	B4	R 535	C2
EP 501	B1	Q 514	C3	R 248	B4	R 536	C2
EP 502	C1	Q 800	A2	R 249	B4	R 537	C3
F 500	C3	Q 801	A1	R 250	B4	R 538	C2
J 201	C3	Q 802	A1	R 251	B4	R 539	B3
J 501	C3	Q 803	A3	R 252	B5	R 540	B3
L 200	C4	Q 804	A3	R 253	A5	R 541	C2
L 201	B4	Q 805	B1	R 254	A5	R 542	C2
L 207	B5	Q 806	B1	R 255	B5	R 543	B3
L 213	B5	R 200	C4	R 256	B5	R 544	C2
L 214	A5	R 205	C5	R 257	A4	R 545	C2
L 215	A5	R 206	C5	R 258	A4	R 546	C3
L 217	B4	R 207	C5	R 259	B4	R 547	C3
L 218	A4	R 208	C5	R 500	B2	R 548	B1
L 219	B4	R 209	C5	R 501	C2	R 549	C1
L 220	B5	R 210	B5	R 502	C2	R 800	B2
L 501	B1	R 211	B5	R 503	B2	R 801	C2
L 502	C1	R 212	B5	R 504	C2	R 802	B2
L 503	C1	R 213	B5	R 505	B2	R 803	B2
L 504	B1	R 214	B5	R 506	C2	R 804	C2
L 800	A1	R 215	B5	R 507	C2	R 805	B2
L 801	B2	R 216	B5	R 508	B2	R 806	B2
Q 200	C5	R 217	B5	R 509	B2	R 807	C2
Q 201	C5	R 218	B5	R 510	C2	R 808	B2
Q 202	B5	R 219	B5	R 511	C2	R 809	B2
Q 203	B5	R 221	B5	R 512	B2	R 810	C2
		R 222	B5	R 513	C1	R 811	B3
		R 225	B4	R 514	B2	R 812	C3
		R 226	B4	R 515	B1	R 813	B3
		R 228	A5	R 516	B1	R 814	B3
				R 517	B2	R 815	B3

800/900 MHz RF BOARD COMPONENT LOCATOR GUIDE (CONT'D)

Comp.	Location
R 816	B3
R 817	A4
R 818	A3
R 819	A4
R 820	C3
R 821	A4
R 822	C3
R 823	B3
R 824	A4
R 825	A3
R 826	A4
R 827	A2
R 828	C3
R 829	B3
R 830	A1
R 831	A3
R 832	A1

Comp.	Location
R 833	A1
R 834	A4
R 835	A3
R 836	A1
R 837	A1
R 838	B3
R 839	A2
R 840	A4
R 841	A4
R 842	A2
R 843	A2
R 845	B3
R 846	B3
R 848	B3
R 849	B2
R 850	A4
R 851	B2

Comp.	Location
R 852	B2
R 853	B2
R 854	B2
R 855	B3
R 856	A1
R 857	B1
R 858	B1
R 859	B1
R 860	A1
R 861	A1
R 862	A1
R 863	B1
U 201	A4
U 500	B2
U 501	B4
U 502	B3

Comp.	Location
U 800	A4
U 801	B3
U 802	B3
U 803	A4
U 804	B3
U 806	A3
Z 200	C5
Z 201	C5
Z 202	A5
Z 203	B4
Z 204A	B5
Z 204B	A5
Z 205	A4
Z 206	A5

**AUDIO/LOGIC BOARD COMPONENT LOCATOR GUIDE**

The following guide can be used to locate components on the audio/logic board layout on pages 9-34 and 9-37. Refer to the grid around the board to determine the approximate location of a component.

Comp.	Location
C 100	A3
C 101	C1
C 102	C1
C 103	C1
C 104	A1
C 105	C1
C 106	C1
C 107	A1
C 108	C2
C 109	C2
C 110	C1
C 111	A2
C 112	B2
C 113	C1
C 114	C2
C 115	B2
C 116	A1
C 117	A2
C 118	B2
C 119	A2
C 120	B2
C 121	B3

Comp.	Location
C 122*	D4
C 123*	D4
C 124*	D4
C 125*	D4
C 126*	D5
C 127*	D4
C 128*	D5
C 300	C4
C 301	C4
C 302	C4
C 303	C5
C 304	C5
C 305	C5
C 306	C5
C 307	C5
C 308	C5
C 309	C5
C 310	C5
C 311	B5
C 312	B5
C 313	B5
C 314	B5

Comp.	Location
C 315	B5
C 316	B5
C 317	B5
C 318	C4
C 319	B5
C 320	B5
C 321	B5
C 322	B5
C 323	B5
C 324	B5
C 325	C4
C 326	B4
C 327	A4
C 328	B5
C 329	C3
C 330	B5
C 331	A4
C 332	A4
C 333	A3
C 334	A4
C 335	A4
C 336	A4

Comp.	Location
C 337	A4
C 338	A4
C 339	A3
C 340	A4
C 341	A4
C 342	A3
C 343	A4
C 344	A3
C 345	A4
C 346	B4
C 347	B4
C 348	B3
C 349	B4
C 350	B4
C 351	B4
C 352	B4
C 353	A4
C 354	B3
C 355	C5
C 356	B5
C 357	A4
C 358	A4

\* Used in low tier models only.

## AUDIO/LOGIC BOARD COMPONENT LOCATOR GUIDE (CONT'D)

Comp.	Location	Comp.	Location	Comp.	Location	Comp.	Location
C 359	C5			R 110	A1	R 158	C2
C 360	B4	J 100	C4	R 111	A2	R 159	C3
C 361	B4	J 101	A3	R 112	A2	R 160	C2
C 362	B4	J 301	C3	R 113	A2	R 161	C1
C 363	C1	J 302	A3	R 114	A1	R 162	C2
C 364	A4	J 303	A5	R 115	C2	R 163	C1
C 365*	C3	J 304*	D5	R 116	B2	R 164	C2
		J 305	C4	R 117	B2	R 165	C3
CR100	C1	P 001*	C4	R 118	C2	R 166	C3
CR101	A2			R 119	B2	R 167	C3
CR102	C2	Q 100	A2	R 120	B2	R 168	C1
CR103	C1	Q 101	C1	R 121	A2	R 169	C3
CR104	C1	Q 102	C1	R 122	C1	R 170	C2
CR105	A1	Q 103	B4	R 123	B4	R 171	C3
CR106	C2	Q 104	B4	R 124	C1	R 172	C3
CR107	A1	Q 105	B4	R 125	A1	R 173	C3
CR108	C3	Q 106	B4	R 126	A1	R 174	C2
CR109	C2	Q 107	C3	R 127	B2	R 175	C3
CR110	A3	Q 108	C3	R 128	B4	R 176	C3
CR111	C2	Q 109	C3	R 129	C1	R 177	B3
CR112	C2	Q 110	C3	R 130	B2	R 178*	D4
CR113	C2	Q 111	A3	R 131	C1	R 179*	D4
CR114	C3	Q 112	D4	R 132	B4	R 180*	D4
CR115	C2	Q 113	D4	R 133	B2	R 181*	D4
CR116	C2	Q 114	D5	R 134	B2	R 182*	D4
CR117	C1	Q 115	D5	R 135	B2	R 183*	D4
CR118	C3			R 136	A1	R 184*	D4
CR119	C2	Q 300	C5	R 137	A1	R 185*	D4
CR120	C3	Q 301	C4	R 138	A1	R 186*	D4
CR121	C2	Q 302	A4	R 139	B4	R 187*	D5
CR122	C2	Q 303	B2	R 140	A1	R 189*	D5
CR123	C3	Q 304	B3	R 141	C2	R 190*	D5
CR124*	D4	Q 305	B4	R 142	C2	R 191*	D5
CR125*	D5	Q 306	A3	R 143	A2	R 192*	D5
CR126*	D4	Q 307	B4	R 144	B4	R 193*	A2
CR127*	D5	Q 308	C5	R 145	B4	R 194*	D5
CR128*	C3	Q 309	D5	R 146	C3	R 196*	D5
CR129	C3			R 147	C2	R 197	C2 (HT) D5 (LT)
CR300	C5	R 100	A3	R 148	C2	R 198	D5
CR301	C5	R 101	A3	R 149	B2	R 199	C2
CR302	A4	R 102	C1	R 150	C2	R 200	D5
CR303	C1	R 103	C1	R 151	C2	R 300	C4
CR304	C2	R 104	C1	R 152	B2	R 301	C5
CR305	C2	R 105	C2	R 153	C2	R 302	C4
DS003	D5	R 106	C1	R 154	A3	R 303	B5
DS004	D5	R 107	B2	R 155	C2	R 304	C5
F 100	A3	R 108	C1	R 156	C2	R 305	C4
F 300	B3	R 109	C1	R 157	C2		

\* Used in low tier models only.

AUDIO/LOGIC BOARD COMPONENT LOCATOR GUIDE (CONT'D)

Comp.	Location	Comp.	Location	Comp.	Location	Comp.	Location
R 306	C5	R 353	B5	R 401	B3	U 103	C2
R 307	C5	R 354	B3	R 402	B4	U 104	B2
R 308	C5	R 355	B5	R 403	B4	U 105	B3
R 309	C4	R 356	A4	R 404	B4	U 106	A2
R 310	C5	R 357	C3	R 405	A4	U 107	A1
R 311	C5	R 358	C4	R 406	B4	U 108	A2
R 312	C5	R 359	B5	R 407	B4	U 109	B2
R 313	C5	R 360	A4	R 408	B4	U 110	A2
R 314	C5	R 361	C3	R 409	A4	U 111	B2
R 315	C5	R 362	B3	R 410	B4	U 112	B2
R 316	C5	R 363	B3	R 411	B4	U 113*	D5
R 317	C5	R 364	B3	R 412	B4	U 300	C5
R 318	C5	R 365	A3	R 413	A4	U 301	B5
R 319	C5	R 366	B3	R 414	B3	U 302	A4
R 320	C3	R 367	A3	R 415	B4	U 303	A4
R 321	C3	R 368	B4	R 416	C5	U 304	C5
R 322	C5	R 369	A3	R 417	C5	U 305	C4
R 323	C4	R 370	A3	R 418	A4	U 306	A4
R 324	C3	R 371	A3	R 419	C5	U 307	C4
R 325	B5	R 372	A4	R 420	B4	U 308	B4
R 326	C3	R 373	A4	R 421	C1	U 309*	C4
R 327	B5	R 374	A4	R 422	C1		
R 328	C4	R 375	A4	R 423	C2	W 100	B2
R 329	C3	R 376	B4	R 424	C3	W 101	B2
R 330	C4	R 377	B4	R 425	B5	W 102	B2
R 331	C4	R 378	A3	R 426	A4	W 103	B2
R 332	B5	R 379	B3	R 427	C4	W 301	B3
R 333	C4	R 380	A4	R 428*	D3	W 302	B3
R 334	B5	R 381	A4	R 429*	D4	W 303	B3
R 335	C4	R 382	A3	R 430*	D4	W 304	B3
R 336	C4	R 383	B3	R 431*	D3	W 305	B4
R 337	B2	R 384	B4	R 432*	D4	W 306	B4
R 338	C4	R 385	B3	R 433*	D4	W 307	B4
R 339	B5	R 386	A4	R 434*	D4	W 308	B4
R 340	B5	R 387	A4	R 435*	D4	W 309	B4
R 341	B5	R 388	A3	R 436*	D4	W 310	B4
R 342	C4	R 389	A4	R 437*	D4	W 311	B3
R 343	B5	R 390	A4	R 438*	D4	W 312	B3
R 344	B5	R 391	A4	R 439*	D4	W 313	B3
R 345	C4	R 392	A4	R 440*	D4	W 314	B3
R 346	C4	R 393	A3	R 441*	D4	W 315	B4
R 347	B5	R 394	B4	R 442*	C4	W 316	B4
R 348	B5	R 395	A4	R 443	C4	W 317	B4
R 349	B5	R 397	A3			W 318	B4
R 350	B5	R 398	C3	U 100	C1	W 319	B4
R 351	B5	R 399	C3	U 101	B1	W 320	B4
R 352	B5	R 400	B4	U 102	C2	Y 100	C1

\* Used in low tier models only.



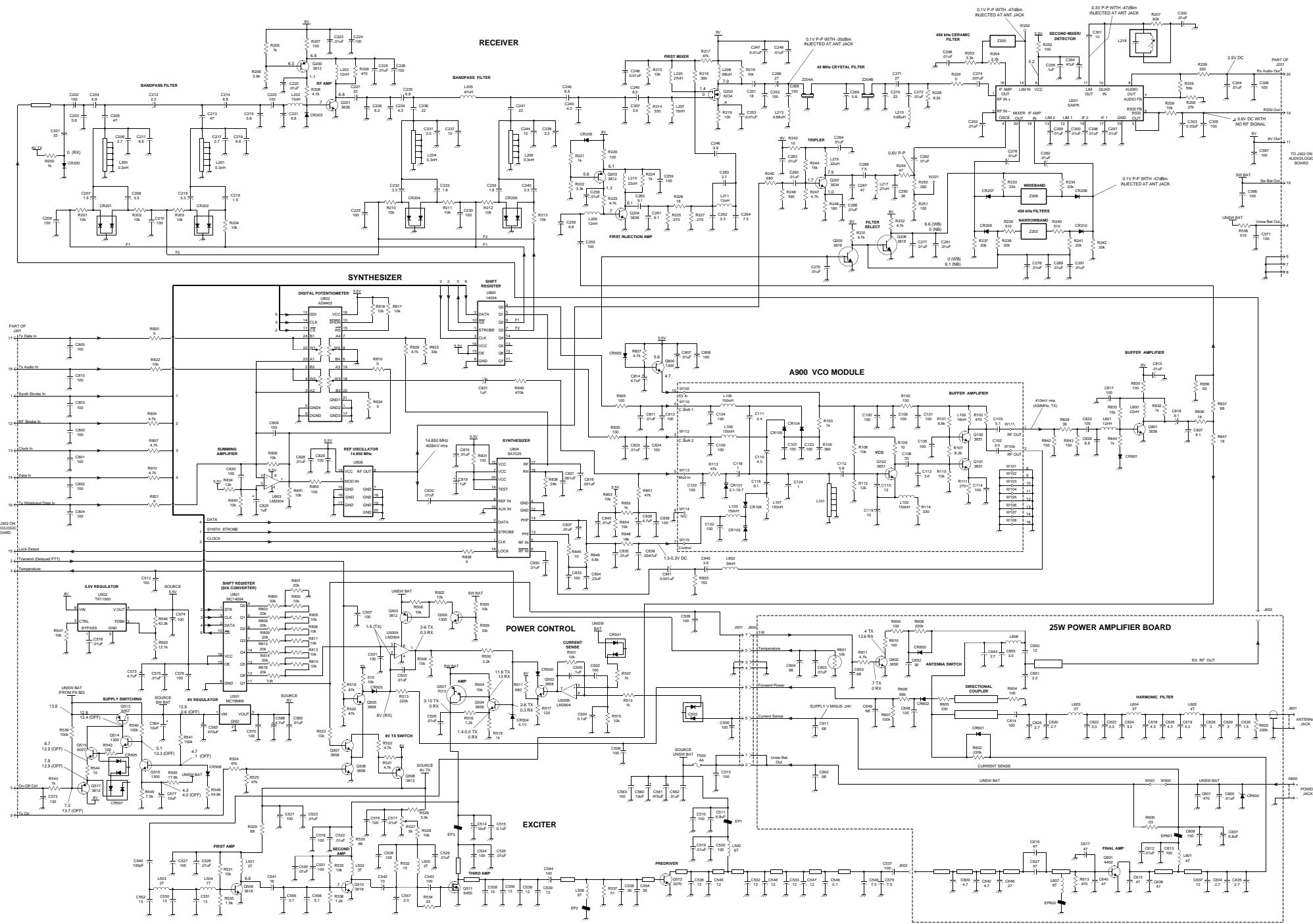

NOTES:  
 1. ALL RESISTORS ARE IN OHMS AND ALL CAPACITORS ARE IN PICOFARADS UNLESS OTHERWISE SPECIFIED.

**RF BOARD SCHEMATIC (REVISED 430-470 MHZ)**

**PA BOARD SCHEMATIC (25W, 430-470 MHZ)**





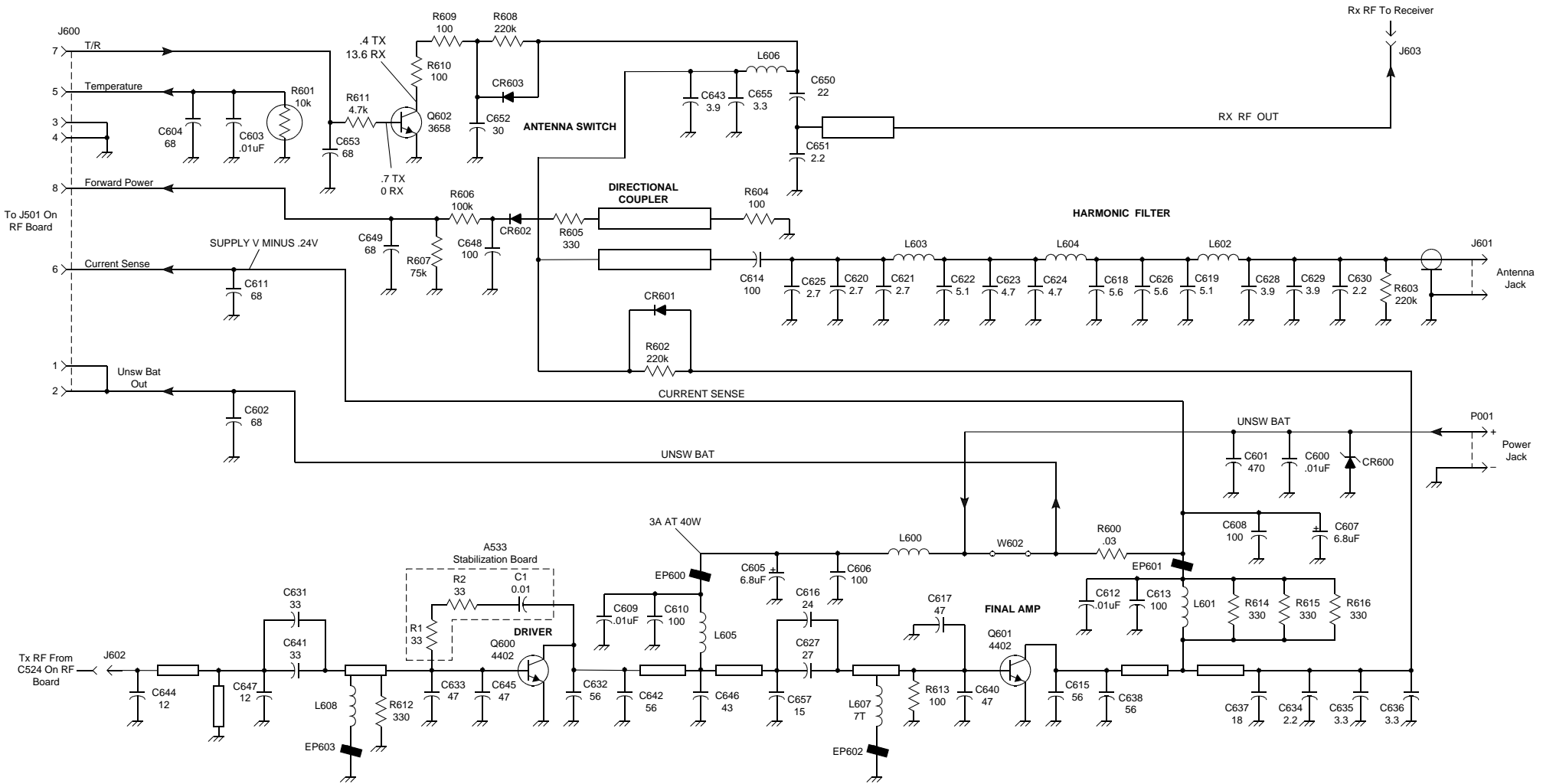

**PA BOARD SCHEMATIC (40W, 430-470 MHZ)**

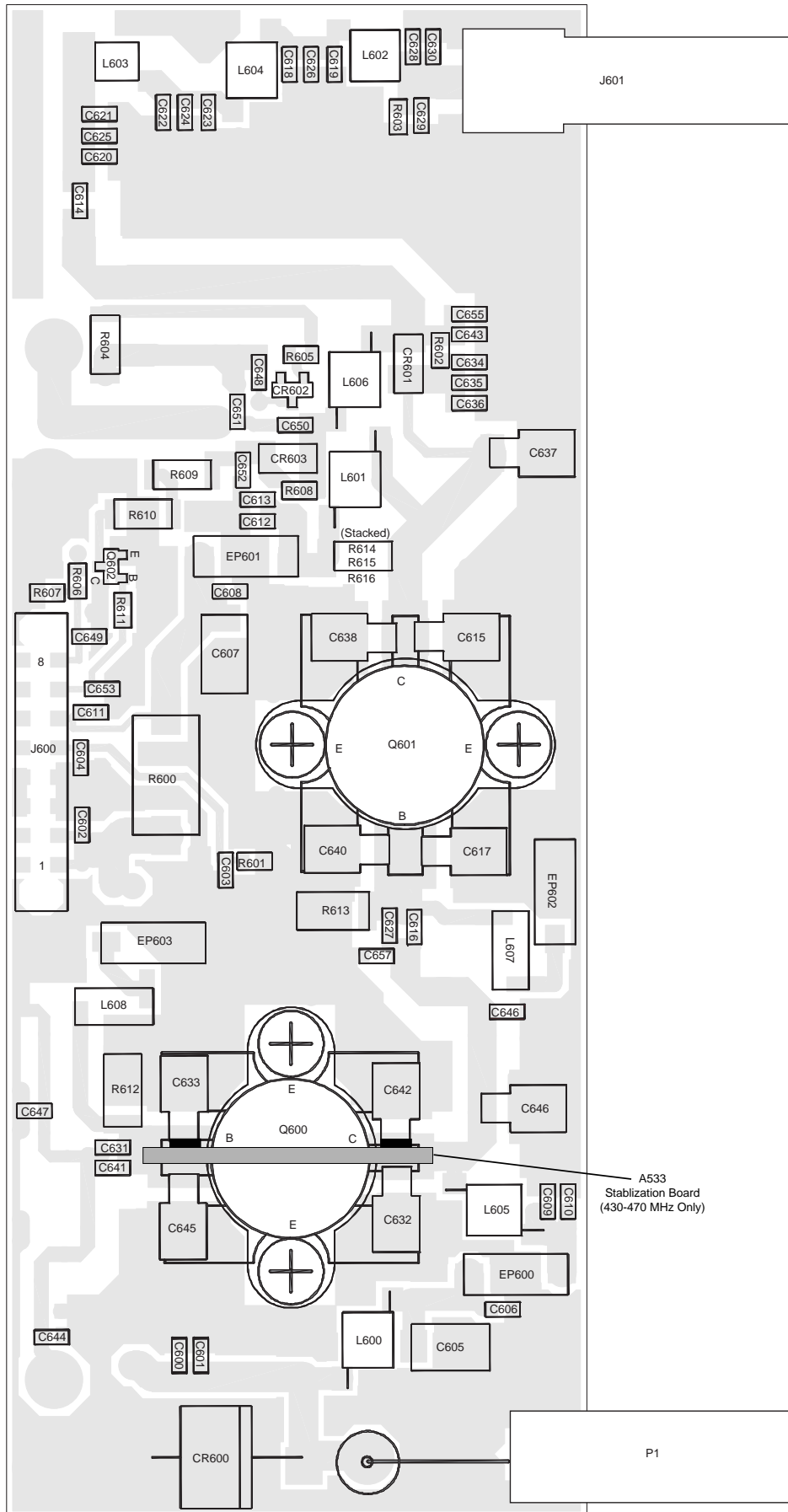

**PA BOARD LAYOUT (40W, 430-512 MHz)**

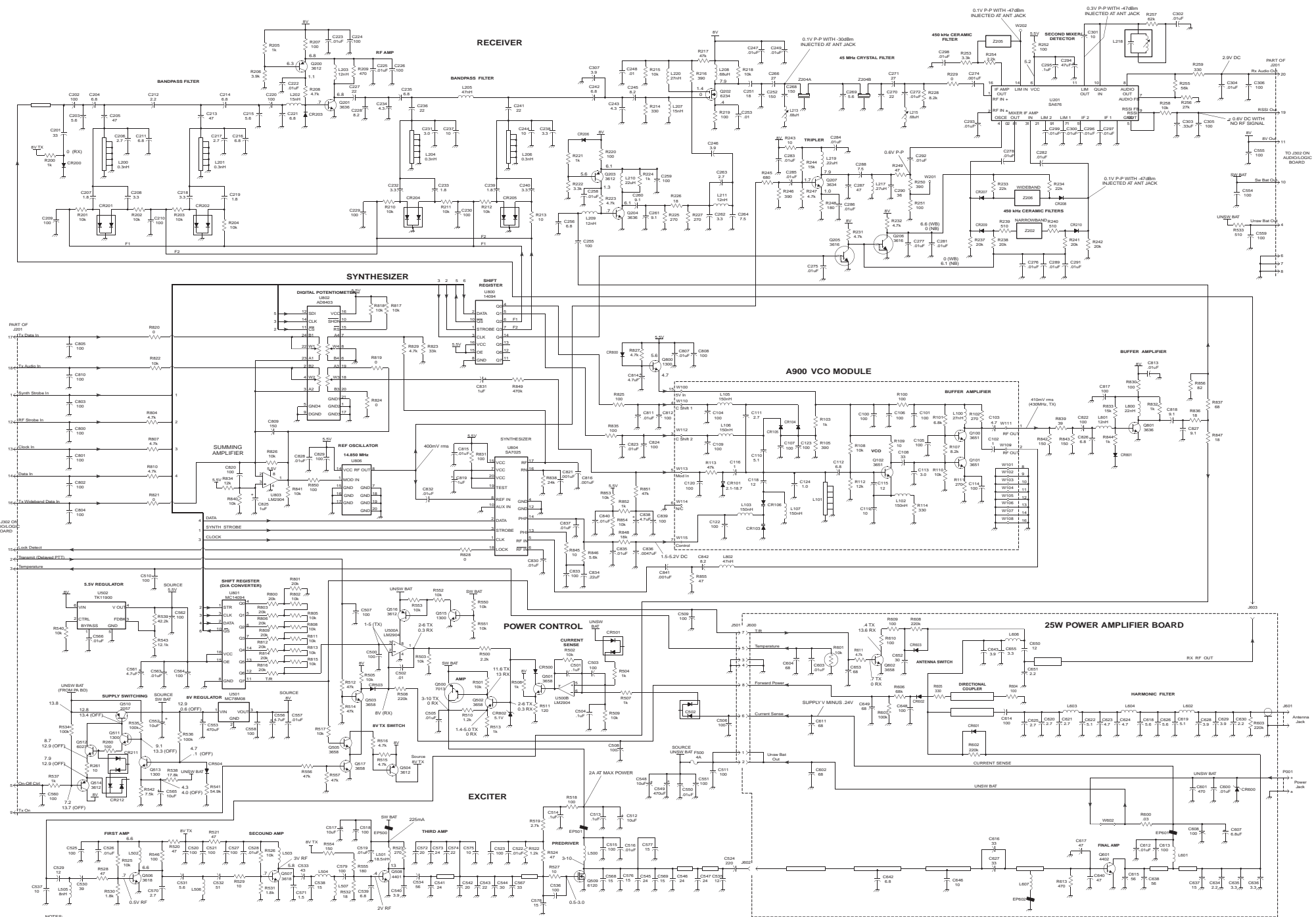

NOTES:  
 1. ALL RESISTORS ARE IN OHMS AND ALL CAPACITORS ARE IN PICOFARADS UNLESS OTHERWISE SPECIFIED.

### RF BOARD SCHEMATIC (UNREVISED 430-470 MHZ)

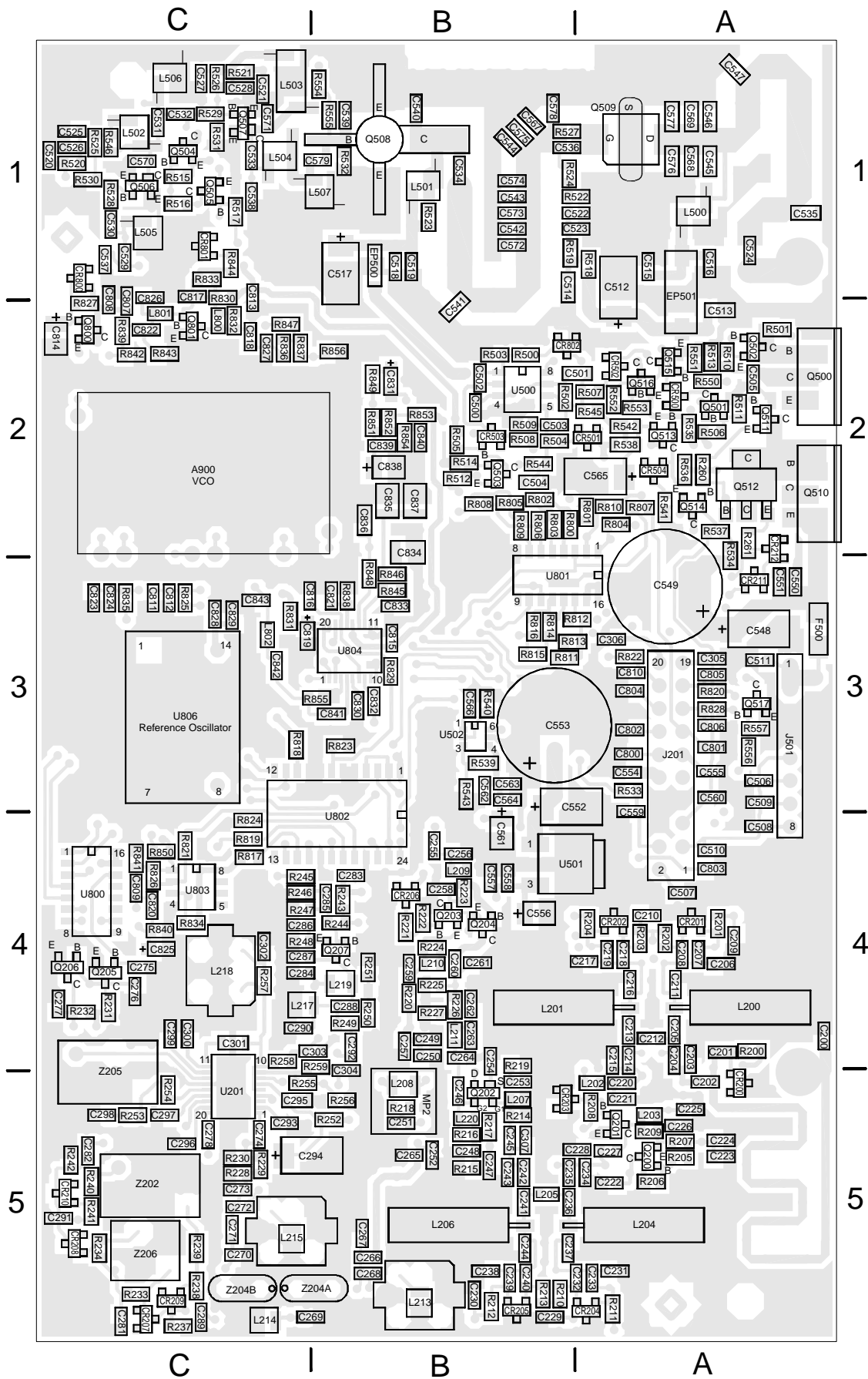

RF BOARD LAYOUT (UNREVISED 430-470 MHZ)

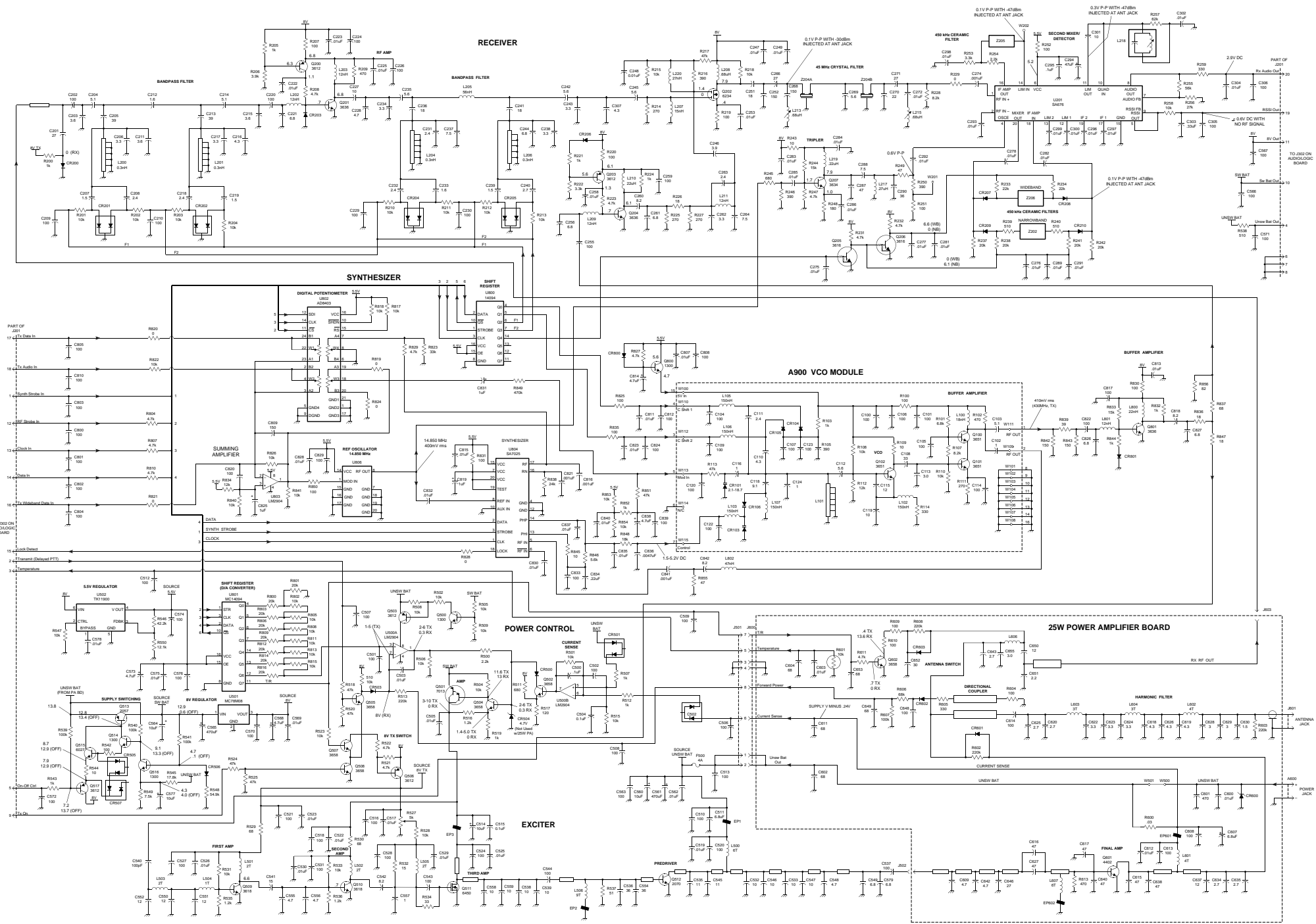

NOTES:  
 1. ALL RESISTORS ARE IN OHMS AND ALL CAPACITORS ARE IN PICOFARADS UNLESS OTHERWISE SPECIFIED.

**RF BOARD SCHEMATIC (470-512 MHZ)**

**PA BOARD SCHEMATIC (25W, 470-512 MHZ)**









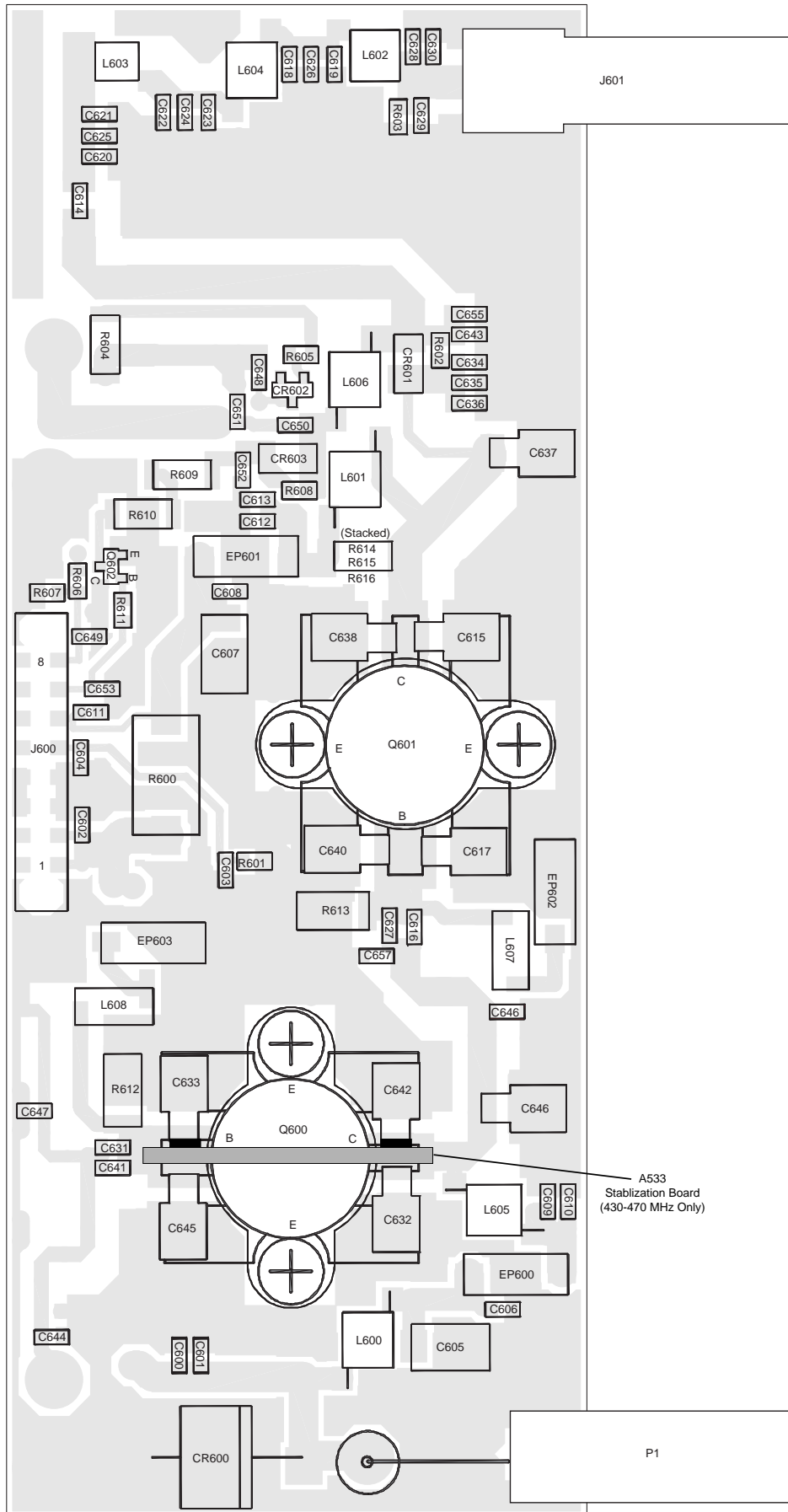

**PA BOARD LAYOUT (40W, 430-512 MHZ)**







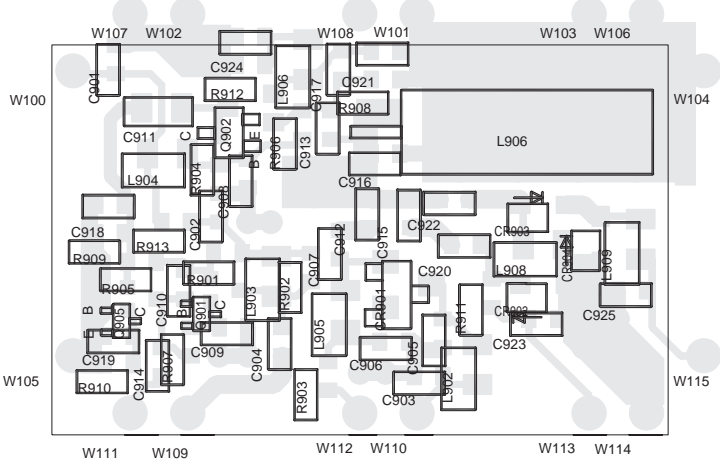
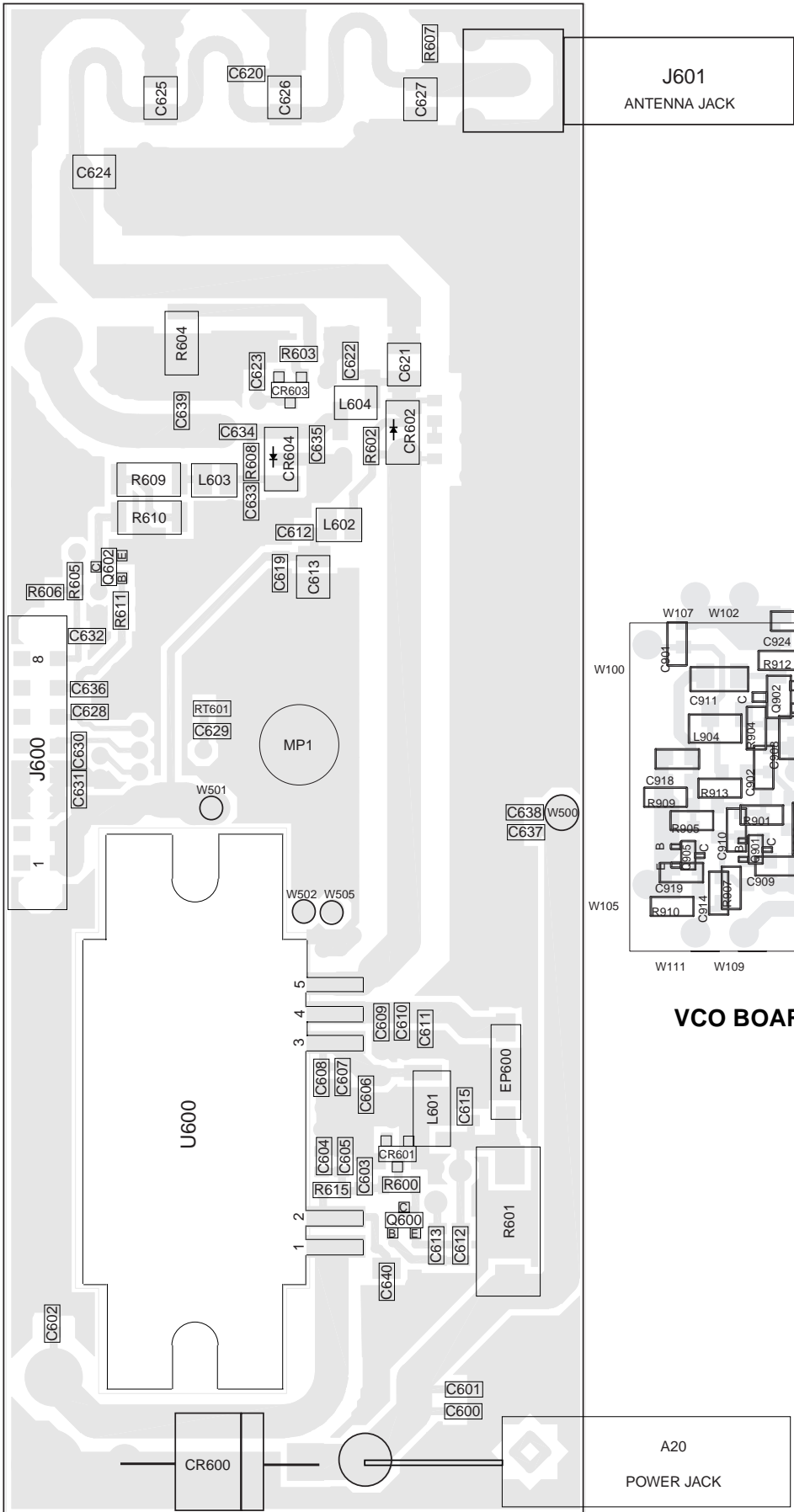

VCO BOARD LAYOUT (800/900 MHZ)

PA BOARD LAYOUT (15W, 800/900 MHZ)











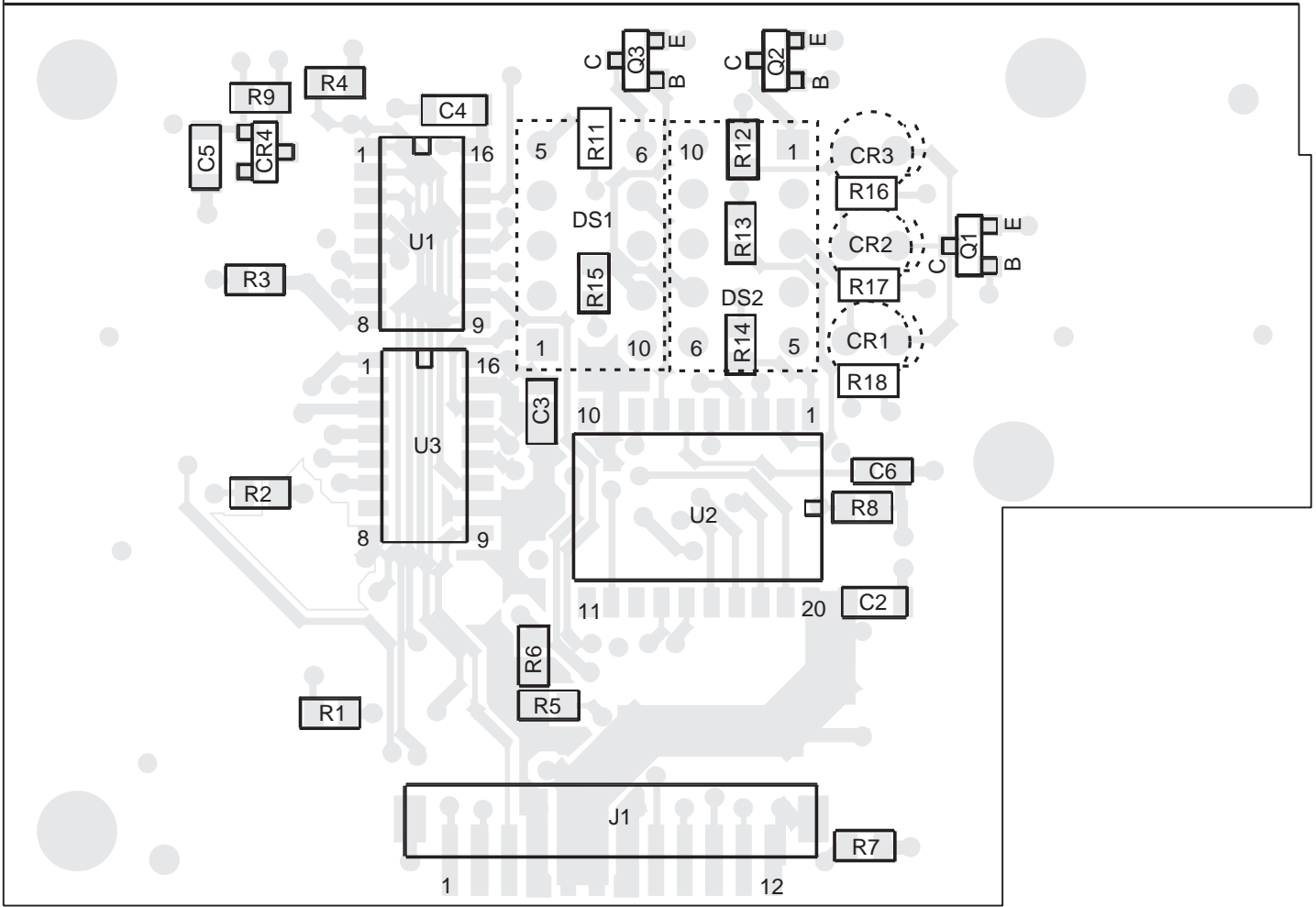

**LOW TIER DISPLAY BOARD (BACK VIEW)**

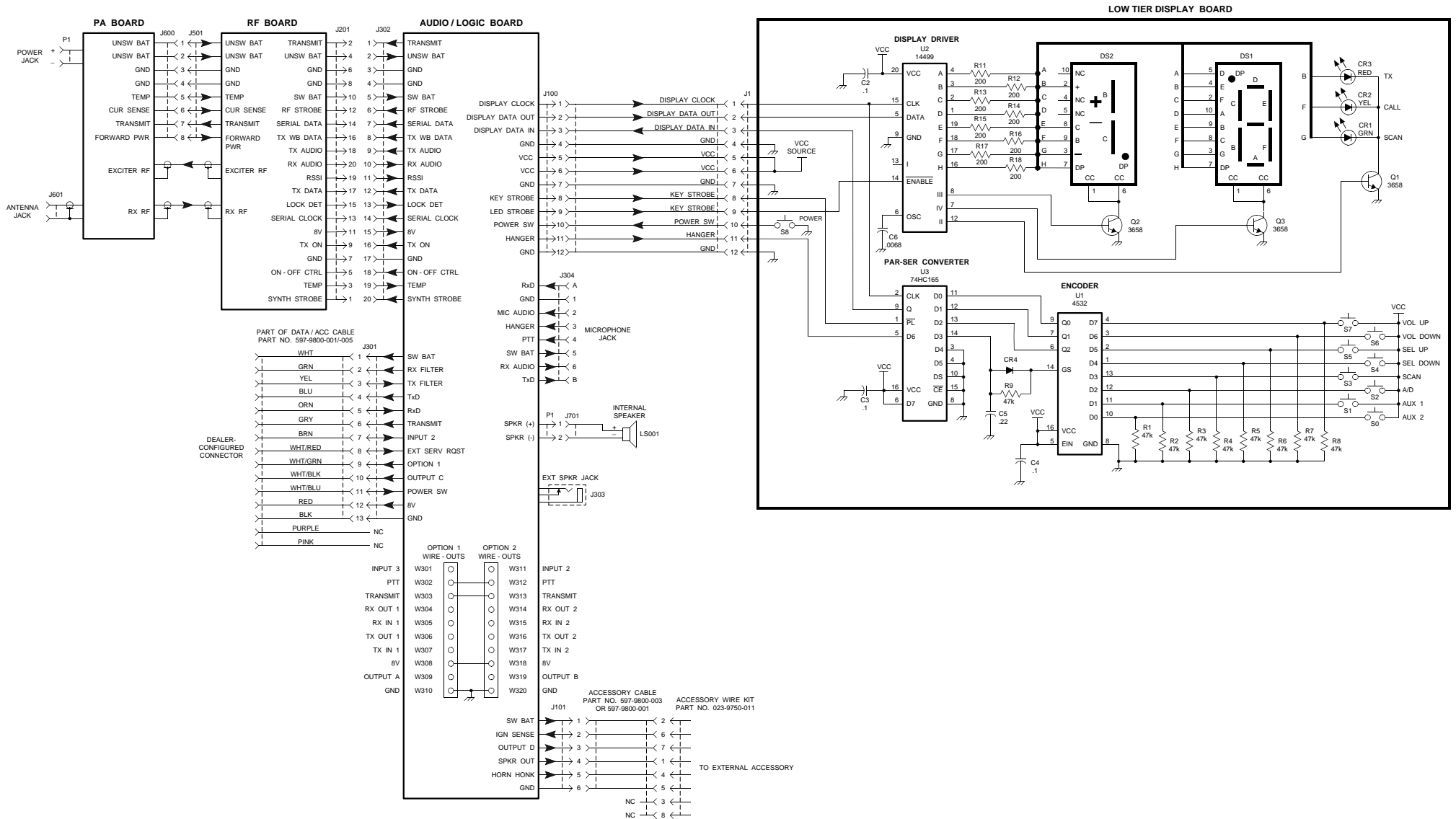

**LOW TIER INTERCONNECT SCHEMATIC**



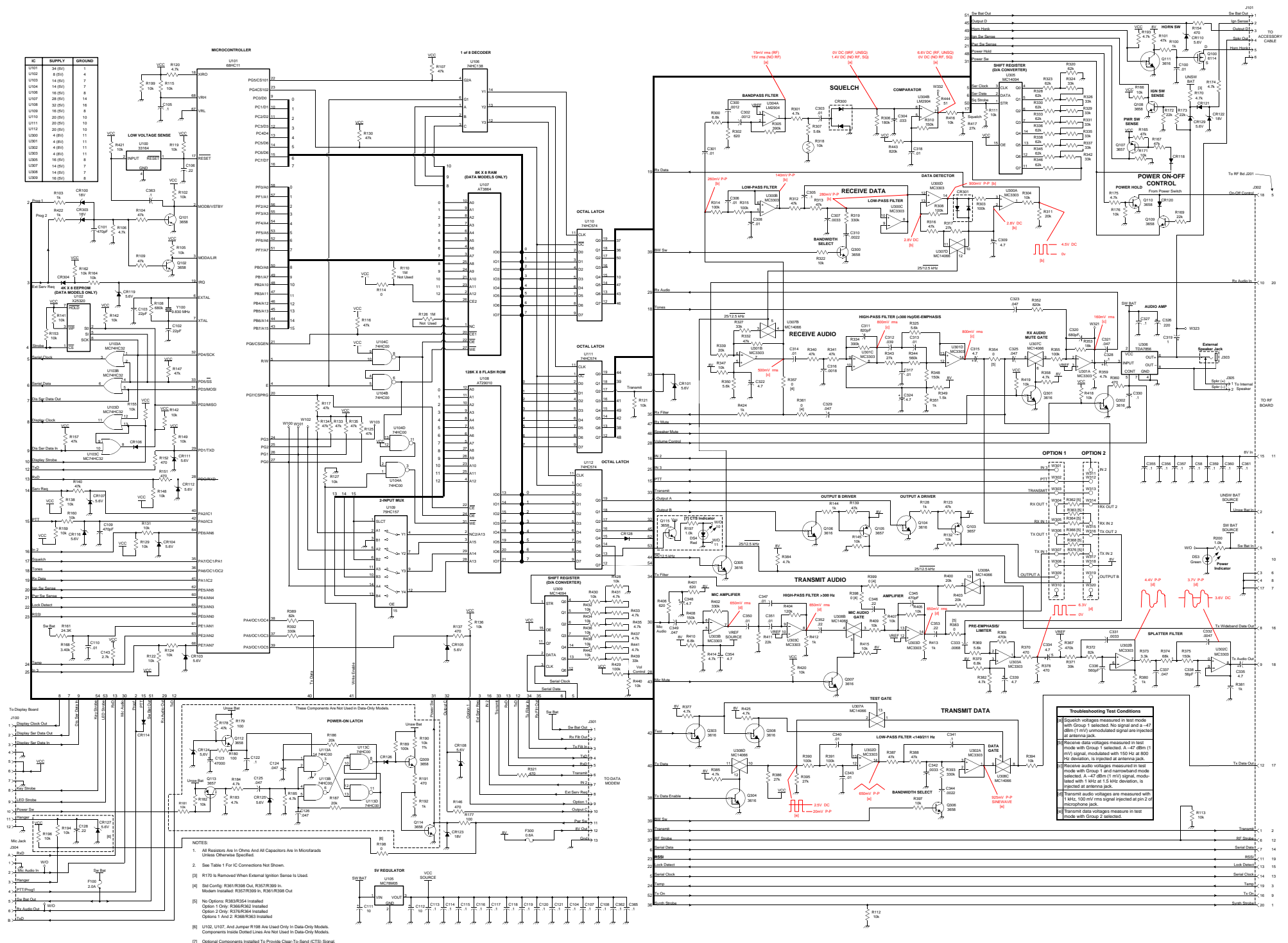

- NOTES:
- All Resistors Are in Ohms And All Capacitors Are in Microfarads Unless Otherwise Specified.
  - See Table 1 For IC Connections Not Shown.
  - R170 Is Removed When External Ignition Sense Is Used.
  - Set Config: R361R368 Out, R357R369 In. Modern Installed: R357R369 In, R361R368 Out.
  - No Options: R368R364 Installed. Option 1 Only: R368R362 Installed. Option 2 Only: R376R364 Installed. Option 1 And 2: R368R363 Installed.
  - U102, U107, And Jumper R198 Are Used Only in Data-Only Models. Components Inside Dotted Lines Are Not Used in Data-Only Models.
  - Optional Components Installed To Provide Clear-To-Send (CTS) Signal.

Test Point	Test Condition
Squelch	Squelch voltages measured in test mode with Group 1 selected. No signal and a -47 dBm (-1 mV) unmodulated signal are rejected at antenna jack.
Receive data	Receive data voltages measured in test mode with Group 1 selected. A -47 dBm (-1 mV) signal, modulated with 100 Hz at 800 Hz deviation, is injected at antenna jack.
Receive audio	Receive audio voltages measured in test mode with Group 1 and narrowband mode selected. A -47 dBm (-1 mV) signal, modulated with 1 kHz at 1.5 kHz deviation, is injected at antenna jack.
Transmit audio	Transmit audio voltages are measured with 1 kHz, 100 mV rms signal injected at pin 2 of microphone jack.
Transmit data	Transmit data voltages measured in test mode with Group 2 selected.



## APPENDIX A DATA INTERFACE DESCRIPTION

### A.1 GENERAL INFORMATION

#### A.1.1 INTRODUCTION

This appendix describes the interface signals provided by 98xx-series low, mid, and high tier and data transceivers for controlling an external modem or other accessories such as encoder, decoder, compandor, and encryption modules.

The interface signals include the data path signal, data control functions, and power sources. Some signal lines have optional functions that are selected by programming as described in \*. I/O lines are programmed on a radio-wide basis which means the I/O functions are the same for all systems and groups. Individual systems and groups cannot be programmed with unique I/O functions.

#### A.1.2 SOFTWARE VERSION REQUIRED

The interface signals described in this appendix are available with all 98xx-series transceivers which

have transceiver (Flash) software Version 204 or later. The software version can be determined by selecting the test mode as described in Section 3.11.2.

Programming software Version 204 or later is required to program the interface signals. The software version number is displayed on the top of most programming screens.

*NOTE: When an external accessory such as an external decoder or compandor module is installed, be sure to program the control line used by the accessory (see Section 4.9.3) as well as enabling it on the applicable systems or groups.*

### A.2 ELECTRICAL SPECIFICATIONS

The electrical characteristics of the various power supply, receive audio, transmit audio, and control signals are summarized in Table A-1.

**Table A-1 Data Interface Line Electrical Specifications**

Name	Origin	Description
<b>Power Supply Lines</b>		
The following power sources are shared with Data Interface connector J301 and internal Option Slots 1 and 2. Therefore, when determining the total supply current requirement, be sure to consider all options installed in these locations.		
Sw Bat Out	J301-1	Standard battery voltage output switched by the transceiver power switch. Maximum source current = 300 mA.
8V Out	J301-12	Regulated 8 VDC $\pm 5\%$ output. Maximum source current = 300 mA.
Ground	J301-13	Transceiver chassis ground.
Pwr Sw	J301-11	This input allows external control of transceiver power. Pulling this line low turns power on and returning it to a floating condition turns power off (if the front panel power switch is off).
<b>Serial Data Bus Signals</b>		
With high tier and data models, the serial data bus can be accessed by intelligent external devices for the purpose of controlling various transceiver functions. The Serial Bus Protocol is described in Appendix B. This bus is also accessed via the microphone jack to perform personality programming and transceiver alignment. Those are the only two serial bus functions available with low and mid tier models.		
TxD	J301-4	Serial transmit data output at TTL levels (unbuffered).
RxD	J301-5	Serial receive data input at TTL levels (unbuffered).

Table A-1 Data Interface Line Electrical Specifications (Continued)

Name	Origin	Description
<b>Receive Audio Signals</b>		
The two receive audio signals which follow are selected by installing either R357 or R361 on the audio/logic board. Only one resistor can be installed at a time. The receive audio line is called "Rx Filt Out" on the schematic.		
Rx Filt Out	J301-2	This output signal is selected by installing R361 and removing R357. It provides a bandpass filtered and de-emphasized receive audio signal that is shared with the internal option slots. Its characteristics are as follows: AC coupled 300 to 3000 Hz TIA, Output Impedance = 1k ohms, Level = 1.7 V p-p at 60% system deviation.
Rx Demod Out	J301-2	This output signal is selected by installing R357 and removing R361. It provides a buffered unfiltered discriminator output signal that is shared with the internal option slots. Its characteristics are as follows: DC coupled (2.8 VDC reference) DC to 5 kHz +1 -3 dB, Output Impedance = 1k ohms, Level = 1 V p-p at 60% system deviation.
<b>Transmit Audio Signals</b>		
The two transmit audio signals which follow are selected by installing either R398 or R399 on the audio/logic board. Only one resistor can be installed at a time. The transmit audio line is called "Tx Filt In" on the schematic.		
Tx Filt In	J301-3	This input signal is selected by installing R398 and removing R399. It bypasses the high-pass filter but still goes through the low-pass splatter filter and undergoes pre-emphasis and deviation limiting. The device producing this signal must provide a means of adjusting deviation externally. The characteristics of this signal are as follows: AC coupled 4 Hz to 3 kHz, Input Impedance = Greater than 10k ohms, Level = 1 V p-p typical for 60% system deviation.
Tx WB In	J301-3	This input signal is selected by installing R399 and removing R398. It bypasses splatter filtering, pre-emphasis, and deviation limiting circuitry, and so provides a direct modulation port. The device producing this signal must provide a means of adjusting deviation externally. In addition, it must provide FCC approved deviation limiting and splatter filter circuitry. <b>The user assumes responsibility for FCC approval when this line is used.</b> The characteristics of this signal are as follows: DC coupled 0 Hz to 4800 Hz, Input Impedance = Greater than 10k ohms, Level = 1 V p-p typical for 60% system deviation, DC coupling requires 2.5 VDC $\pm$ 2% reference.
<b>Input Control Signals</b>		
All of the following input control lines are CMOS inputs that are pulled high internally (to 5V) with 10k-ohm resistors. None of these inputs are equipped for switch debounce, so that must be provided if applicable. All except Ext Serv Req can be programmed either active high or low. These lines are programmed as described in Section 4.9 for the functions described in Table A-2.		
In 2	J301-7	Programmable input.
In 3	W301	Programmable input.
Ext Serv Req	J301-8	This line is not programmable and is always active low.
PTT	W302/W312	This line is not programmable and is always active low (low state keys transmitter).
Option 1	J301-9	Programmable as either an input or output. When programmed as an input and a state change occurs, microprocessor interrupts are produced. All I/O lines are then checked for state changes. This allows a signal such as "Data PTT" to get a rapid response.
<b>Output Control Signals</b>		
Unless noted otherwise, all of the following input control lines are 5-volt CMOS outputs with a 470-ohm output impedance and capable of sourcing 10 mA maximum. All, except when noted otherwise, can be programmed either active high or low. These lines are programmed as described in Section 4.9 for the functions described in Table A-2.		
Output A	W309	Programmable output.
Output B	W319	Programmable output.
Output C	J301-10	Programmable output.
Output D	J101-3	Programmable output.

**Table A-1 Data Interface Line Electrical Specifications (Continued)**

Name	Origin	Description
Output E	U112-14	Not programmable and always the “Rx Data Call” function and active high (not available with data and low tier models).
Output F	U112-13	Not programmable and always the “Data CTS” function and active high (not available w/low tier).
Option 1	J301-9	Programmable as either an input or output.
Transmit	W303/W313	This line is not programmable and is active high (high = transmitter keyed indication).

### A.3 SIGNAL FUNCTIONS

#### A.3.1 INTRODUCTION

Most of the input and output lines described in the preceding section can be programmed for the functions indicated in Table A-2. Low and mid tier models have fewer functions available for each line than high tier and data models. The programming of these input/output lines is described in Section 4.9.

#### A.3.2 DEFINITIONS

The following terms are used frequently in this section:

**Asserted** - The state of an electrical signal when it is active. The signal is “asserted” with active high lines when the signal is high, and with active low lines when it is low.

**Released** - The state of an electrical signal when it is inactive. The signal is “released” with active high lines when the signal is low, and with active low lines when it is high.

#### A.3.3 INPUT FUNCTIONS

The following are descriptions of the input functions listed in Table A-2.

**AUDIO MUTE** - This input forces the radio to mute microphone and speaker audio when it is asserted.

**CALL GUARD** - Conventional groups may be programmed to utilize an external decoder. This signal must be asserted to receive a call on one of these groups.

**CALL GUARD DISABLE** - The asserted condition disables both receive and transmit Call Guard squelch on the selected system/group. Operation is the same as when the CG Disable option switch is pressed (see Section 3.9.5).

**DATA ARQ** - This signal is used in conjunction with the DATA PTT signal to perform rapid channel turnaround. Refer to Section A.4 for more information on DATA ARQ operation.

**DATA PTT** - This input signal indicates that the external device wants to access a data system and group. The data group access function is performed (a data group is found) and the system is accessed. If the DATA ARQ function is programmed, it is used in conjunction with the DATA PTT signal as described in Section A.4.

When the transmission is complete (DATA PTT released), the radio remains on the data system and group until a normal operation causes it to move to another system and group. Examples of normal operations include when scanning resumes due to the call timer expiring and when the user manually changes system or group. Note that once DATA PTT is asserted, the normal microphone PTT signal is inhibited until DATA PTT is released. In addition, the high tier emergency function takes precedence over DATA PTT.

**DATA PTT REVERT** - This input signal operates the same as the preceding DATA PTT function except as follows: As soon as the DATA PTT REVERT is released, the radio immediately returns to the system and group it was on when the DATA PTT REVERT was first asserted. This function may delay data access time.

**EMERGENCY** - Asserting this signal causes the radio to act as if the “Emergency” switch has been pressed.

**EXT SERV REQ** - Normally, all input lines are polled on a regular basis (approximately every 40 ms) to detect changes. Under certain conditions, such as to improve response time or to make sure a transition is not missed, it is desirable to force a check of the input lines. This is done by asserting the EXT SERV REQ line (applying a high to low transition). This line is a main microprocessor interrupt that when asserted, causes the radio software to immediately check and then process any input state changes on In 2 and In 3.

**HORN** - When asserted, this signal initiates a horn honk event (see Section 3.5.10). The alert sounds for the fixed or programmed number of cycles and then returns to the disabled state. For the alert to sound again, this signal must be released and re-asserted.

**PTT** - When this signal is asserted, it is treated as a normal microphone (voice) PTT signal. While it is asserted, DATA PTT (and DATA PTT REVERT) are inhibited. The high tier Emergency function takes precedence over this PTT signal. Data and voice group hunting are inhibited, so access occurs on the current revert system and group.

**PTT INHIBIT** - This signal prevents any action from being taken in response to user or control unit PTT signals. DATA PTT operation is not affected when this line is asserted.

### A.3.4 OUTPUT FUNCTIONS

The following are descriptions of the output functions listed in Table A-2.

**ACCESSORY OPTION** - This is the output signal for the option select function that is toggled by an option switch or the menu OPTION parameter (see Section 3.5.11). The asserted condition = option enabled.

**AUDIO ENABLE** - When this output is asserted, either microphone or speaker audio is enabled, depending on whether the transmit or receive mode is active.

**BUSY** - When transmitting, the asserted condition indicates that an attempt to transmit failed because the channel or system was busy. When receiving, it indicates that the current channel or system/group is busy.

**CALL GUARD** - If the conventional group is programmed for Call Guard squelch, the asserted condition indicates that the correct Call Guard code is being detected. If the conventional group is not programmed for Call Guard squelch, this line is asserted when unsquelched (audio enabled) and released when squelched.

**CALL INDICATOR** - The asserted condition indicates that the call indicator is active.

**CLEAR TO SEND** - The asserted condition indicates that the radio has completed all channel access activity and is ready for the external device to begin sending audio or data.

**COMPAND** - The asserted condition indicates that companding should be activated for the transmit and receive modes.

**DATA CTS** - The asserted condition indicates that the radio has completed all channel access activity on a data group/channel and is ready for the external device to begin sending data.

**ENCRYPT** - The asserted condition indicates that all transmitted audio should be encrypted. This is controlled with a combination of group programming and a menu parameter or option switch (see Section 3.5.7).

**MONITOR HANGER** - This output mirrors the “logical” microphone hanger status. It is asserted when an on-hook condition is indicated by the local microphone and also all control units (if applicable).

**PTT PRESSED** - The asserted condition indicates that the user PTT switch is pressed in at least one location such as the local microphone or a control unit.

**RSSI** - The asserted condition indicates a “fast” carrier detect condition. On early models, it uses the received signal strength indication (RSSI), and on later models with the faster noise squelch circuit, it uses the squelch circuit output.

**RX CALL** - The asserted condition indicates that a call is being received (either voice or data).

**RX DATA GROUP** - The asserted condition indicates that a call is being received on a data group.

**SEND CALL GUARD** - The asserted condition indicates to an external device when the radio is transmitting that it should send the transmit tone or other signaling.

**TX FAIL** - The asserted condition indicates that an attempted PTT or DATA PTT channel access has failed. Possible reasons for this failure on a trunking system are an out of range or system busy condition. On a conventional channel it usually means the channel is busy. This signal is also asserted when a transmitter time-out occurs or an over voltage condition exists. It is not released until all "PTT" signals have been released.

**Table A-2 Input/Output Line Programmable Functions**

Line Name	Origin	Direction	Functions		
			Low Tier	Mid Tier	High Tier & Data
Sw Bat Out	J301-1	Out	Fixed	Fixed	Fixed
Rx Filt Out	J301-2	Out	Fixed	Fixed	Fixed
Tx Filt In	J301-3	In	Fixed	Fixed	Fixed
TxD	J301-4	Out	Fixed	Fixed	Fixed
RxD	J301-5	In	Fixed	Fixed	Fixed
Transmit	J301-6	Out	Fixed	Fixed	Fixed
Pwr Sw	J301-11	In	Fixed	Fixed	Fixed
8V Out	J301-12	Out	Fixed	Fixed	Fixed
Ground	J301-13	N/A	Fixed	Fixed	Fixed
Ext Serv Req	J301-8	In	Ext Serv Req	Ext Serv Req	Ext Serv Req
In 2	J301-7	In	Data PTT Data PTT Revert PTT	Call Guard Disable Data PTT Data PTT Revert PTT	Audio Mute Call Guard Call Guard Disable Data ARQ Data PTT Data PTT Revert Emergency Ext Call Guard Horn PTT PTT Inhibit
In 3	W301	In	Ext Call Guard	Audio Mute Call Guard Call Guard Disable Ext Call Guard Data ARQ	Audio Mute Call Guard Call Guard Disable Data ARQ Data PTT Data PTT Revert Emergency Ext Call Guard Horn PTT PTT Inhibit

Table A-2 Input/Output Line Programmable Functions (Continued)

Line Name	Origin	Direction	Functions		
			Low Tier	Mid Tier	High Tier & Data
Option 1	J301-9	In	Audio Mute Data ARQ Data PTT Revert PTT	Data ARQ Rx Data Group	Audio Mute Call Guard Call Guard Disable Data ARQ Data PTT Data PTT Revert Emergency Horn PTT PTT Inhibit
		Out	Rx Call Rx Data Group	Accessory Option Audio Enable Audio Mute PTT Inhibit Rx Call	Accessory Option Audio Enable Busy Call Guard Call Indicator Clear To Send Compand Data CTS Encrypt Monitor Hanger PTT Pressed RSSI Rx Call Rx Data Group Send Call Guard Tx Fail
Output A	W309	Out	Encrypt Send Call Guard Monitor Hanger	Encrypt Send Call Guard Monitor Hanger	Accessory Option Audio Enable Busy Call Guard Call Indicator Clear To Send Compand Data CTS Encrypt Monitor Hanger PTT Pressed RSSI Rx Call Rx Data Group Send Call Guard Tx Fail

Table A-2 Input/Output Line Programmable Functions (Continued)

Line Name	Origin	Direction	Functions		
			Low Tier	Mid Tier	High Tier & Data
Output B	W319	Out	Compend Send Call Guard Monitor Hanger	Compend Send Call Guard Monitor Hanger	Accessory Option Audio Enable Busy Call Guard Call Indicator Clear To Send Compend Data CTS Encrypt Monitor Hanger PTT Pressed RSSI Rx Call Rx Data Group Send Call Guard Tx Fail
Output C	J301-10	Out	Clear To Send Data CTS Tx Fail	Audio Enable Busy Clear To Send Data CTS Tx Fail	Accessory Option Audio Enable Busy Call Guard Call Indicator Clear To Send Compend Data CTS Encrypt Monitor Hanger PTT Pressed RSSI Rx Call Rx Data Group Send Call Guard Tx Fail
Output D	J101-3	Out	Accessory Option	Accessory Option	Accessory Option Audio Enable Busy Call Guard Call Indicator Clear To Send Compend Data CTS Encrypt Monitor Hanger PTT Pressed RSSI Rx Call Rx Data Group Send Call Guard Tx Fail
Output E	U112-14	Out	N/A	Rx Data Call	Rx Data Call
Output F	U112-13	Out	N/A	Data CTS	Data CTS

## A.4 DATA MODEM OPERATION

### A.4.1 DATA GROUP SUPPORT

The 9800-series radio includes support for data groups. A group programmed as a data group has the following properties:

#### Muting

Whenever the radio is on a group flagged as a data group, both the speaker audio and microphone audio are muted. This prevents the user from hearing or interfering with data transmissions.

#### Data Group Hunt

When the radio detects a DATA PTT or DATA PTT REVERT, it “hunts” for a data group to transmit on. The hunt procedure is as follows:

1. If the current revert (currently or last selected) group is a data group, transmission occurs on that group.
2. If the current revert group is not a data group, the revert system is checked for a data group starting with the first assigned group. If one is found, transmission occurs on that group.
3. If the current revert system has no data groups, the current bank is checked for a data system and group. If a data system and group are programmed, transmission occurs on that group.
4. If all of the above fail, the error tone sounds and “U” (low tier models) or “NO DT GP” (mid and high tier models) is displayed.

#### Voice Group Revert

If the radio is on a data group when a normal microphone PTT is detected, it attempts to revert to a voice group using the following procedure:

1. If the revert (currently or last selected) system and group are a voice group, transmission occurs on that group.
2. If the revert system and group are a data group, transmission occurs on the last user selected system and group.

3. If the last user selected system and group are a data group, the radio sounds the error tone and displays “U” (low tier) or “DATA GRP” (mid/high tier).

### A.4.2 DATA ARQ MODE

#### Introduction

Data ARQ, as used in a trunked radio system, is a method of rapidly changing between the transmit and receive modes without handshaking. This allows data devices that send short messages and expect immediate acknowledgments to get these acknowledgments without experiencing normal trunking delays.

#### Modem Initiated Transmission:

1. The modem initiates a “Data” transmission by asserting the DATA PTT line followed by asserting the DATA ARQ line. The DATA PTT line must remain asserted for the entire data transmission and acknowledge session.
2. After a successful access of the channel/system, the modem must release the DATA ARQ line as it transmits the data.
3. The modem must assert the DATA ARQ line for reception of any ACKs or NACKs. During this time the radio does not decode any subaudible data.
4. For all subsequent assert to release transitions on the DATA ARQ line, the radio transmits with subaudible data.
5. For all subsequent release to assert transitions on the DATA ARQ line, the radio receives without decoding subaudible data.
6. The data session is completed by the release of the DATA PTT line. At this time the mobile transmits the turnoff code and returns to the idle state.

#### Modem Initiated Reception:

1. The modem initiates a “Data” reception by asserting the DATA ARQ line during the reception of a “call” on a “Data Group”. The DATA ARQ line must remain asserted for the entire data transmission and acknowledge session.



2. The modem must assert the DATA PTT line for transmission of any ACKs or NACKs. During this time the radio does not encode any subaudible data.
3. The modem must release the DATA PTT line for the reception of any more data. During this time the radio decodes subaudible data.
4. For all subsequent release-to-assert transitions on the DATA PTT line, the radio transmits without encoding sub-audible data.
5. For all subsequent assert to release transitions on the DATA PTT line, the radio receives and decodes subaudible data.
6. The data session is completed by the release of the DATA ARQ line.



## APPENDIX B EXTERNAL SERIAL CONTROL PROTOCOL

### B.1 INTRODUCTION

#### B.1.1 GOALS OF THIS PROTOCOL

The goals of this protocol are as follows:

- To use a standard type of signaling that is supported by typical embedded microprocessors (or their support chips).
- To support single- or multi-drop operation.
- To provide a method of verifying message integrity.

These goals are realized in the protocol by using “packets” (or “messages”) that use EIA232 protocol (at TTL voltage levels) and contain the following:

- Framing characters
- Source and destination addressing
- A checksum

#### B.1.2 PROTOCOL LAYERS

The protocol has the following three “layers”:

Application Command
Message Framing
Physical Signaling

- The Physical Signaling layer is not covered in this document. It may vary somewhat depending on the hardware implementation.
- Message Framing is discussed in the next section.
- The Application Commands comprise the rest of the document.

*NOTE: While the protocol has been designed to operate in a multi-drop environment, the current platform radio software does not support multi-drop operation.*

### B.2 MESSAGE FRAMING AND FORMATTING

#### B.2.1 FRAME FORMAT

- The message (packet) level information exchange protocol uses a variable length message format.
- The protocol uses a SYNC character to indicate the start of a frame and an ESCape character to signal the end of a frame.
- A DLE character and a replacement character from Table B-1 are used when the message byte contains an embedded SYNC, ESCape, or DLE character.
- SYNC and ESCape patterns are not permitted at any time within the message.
- On transmission, embedded control characters are detected and replaced with an index character.
- On reception, the replacement character is restored by using the replacement value as an index into a replacement table.

**Table B-1 Control Character Replacement Index**

Control Character	Replacement Index
SYNC (0xba)	0x00
ESCape (0x7e)	0x01
DLE (0x10)	0x02

The format of the messages is shown in Table B-2.

Table B-2 Message Format

Sync	Source Address	Destination Address	Opcode	Data	Checksum	Escape
1 byte	1 byte	1 byte	1 byte	0-n bytes	1 byte	1 byte
0xba	0x0?	0x0?	0x??	0x??	0x??	0x7e

**Sync** - The first character of each message.

**Source Address** - The originating device.

**Destination Address** - The intended receive device (only the subscriber unit may use 0xff to broadcast messages).

**Opcode** - Indicates what message is being sent.

**Data** - Opcode data, if needed.

**Checksum** - Two's complement of the sum of the original characters in the message excluding initial SYNC, final ESCAPE, and inserted DLE/replacement characters. The checksum is implemented as a single byte, with all overflow ignored.

**Escape** - The last character of each message.

### B.2.2 FRAME ENCODING/DECODING EXAMPLES

#### No Embedded Special Characters

Sample Data Packet:

Source Address	Destination Address	Opcode	Data
0x01	0x02	0x37	0x02

Formatted data string:

0xba, 0x01, 0x02, 0x37, 0x02, 0xc4, 0x7e

#### Embedded Sync Character

Sample Data Packet:

Source Address	Destination Address	Opcode	Data
0x01	0x02	0x37	0xba

Formatted data string:

0xba, 0x01, 0x02, 0x37, 0x10, 0x00, 0x0c, 0x7e

#### Embedded Escape Character

Sample data packet:

Source Address	Destination Address	Opcode	Data
0x01	0x02	0x37	0x7E

Formatted data string:

0xba, 0x01, 0x02, 0x37, 0x10, 0x01, 0x48, 0x7e

#### Embedded DLE Character

Sample data packet:

Source Address	Destination Address	Opcode	Data
0x01	0x02	0x37	0x10

Formatted data string:

0xba, 0x01, 0x02, 0x37, 0x10, 0x02, 0xb6, 0x7e

#### Multiple Embedded Characters

Sample data packet:

Source Address	Destination Address	Opcode	Data
0x01	0x02	0x37	0x10, 0x33, 0xFF, 0xba, 0xba

Table B-3 Opcode Summary

Opcode	Page No.	Function
0x00	B-7	INFO BUS ACCESS PERMITTED
0x01	-	-reserved-
0x02	B-7	EVENT POWER ON REQUEST
0x03	B-7	CMD POWER UP
0x04	B-8	EVENT POWER OFF REQUEST
0x05	B-8	EVENT POWER OFF
0x06	B-17	EVENT OUTPUT
0x07	B-14	EVENT DISPLAY UPDATE
0x08	-	-reserved-
0x09	B-18	EVENT PTT PRESSED
0x0a	B-18	EVENT PTT RELEASED
0x0b	B-17	EVENT INPUT
0x0c	B-16	EVENT HOOK SWITCH
0x0d	B-19	EVENT VOLUME SET
0x0e	B-5	NAK
0x0f	B-5	ACK
0x10	B-1	DLE
0x11 - 0x1F	-	-reserved-
0x20	B-16	EVENT GROUP SELECT
0x21	B-26	CMD ENTER REMOTE MODE
0x22	B-26	CMD EXIT REMOTE MODE
0x23	B-26	CMD REMOTE NOTIFICATIONS
0x24	B-26	CMD SET CALL GUARD
0x25	B-27	CMD SET FREQ
0x26	B-28	CMD SET IF BANDWIDTH
0x27	B-28	CMD SET POWER LEVEL
0x28	B-21	CMD SET USER SQUELCH
0x29	B-28	CMD START TX
0x2a	B-28	CMD STOP TX
0x2b	-	-reserved-
0x2c	-	-reserved-
0x2d	-	-reserved-
0x2e	-	-reserved-
0x2f	B-28	CMD SET SQUELCH CIRCUIT
0x30	-	-reserved-
0x31	-	-reserved-
0x32	B-10	CMD RESET WARM
0x33	-	-reserved-
0x34	B-10	CMD RESET POWER UP
0x35	-	-reserved-
0x36	B-10	CMD REQUEST BANK NAMES
0x37	B-10	CMD REQUEST GROUP NAMES
0x38	B-11	CMD REQUEST SYSTEM NAMES

Table B-3 Opcode Summary (Continued)

Opcode	Page No.	Function
0x39	B-11	CMD REQUEST SOFTWARE VERSION
0x3a	B-11	CMD REQUEST SYSTEM GROUP
0x3b	B-11	CMD UI NOTIFICATIONS
0x3c	B-21	CMD BLOCK DECODE
0x3d	B-21	CMD CLEAR LOCKOUT GID
0x3e	B-22	CMD GET LOCKOUT GID
0x3f	B-17	EVENT KEYPAD
0x40	B-11	EVENT AUDIO GATE
0x41	B-13	EVENT BANK SELECT
0x42	B-13	EVENT DATA ARQ ASSERTED
0x43	B-13	EVENT DATA ARQ RELEASED
0x44	B-13	EVENT DATA PTT PRESSED
0x45	B-13	EVENT DATA PTT RELEASED
0x46	B-18	EVENT SOUND
0x47	B-18	EVENT SYSTEM SELECT
0x48	B-23	EVENT CALL
0x49	B-23	EVENT SCAN
0x4a	B-24	EVENT TRANSMIT
0x4b - 0x4f	-	-reserved-
0x50	B-18	EVENT Rotary
0x51	B-22	CMD RADIO NOTIFICATIONS
0x52	B-22	CMD GET RADIO STATUS
0x53	B-22	CMD SET LOCKOUT GID
0x54	B-23	CMD SET GID
0x55 - 0x5f	-	-reserved-
0x60	B-19	INFO BANK NAME
0x61	B-19	INFO GROUP NAME
0x62	B-20	INFO SOFTWARE VERSION
0x63	B-20	INFO SYSTEM GROUP
0x64	B-21	INFO SYSTEM NAME
0x65	B-25	INFO LOCKOUT GID
0x66	B-23	INFO RADIO STATUS
0x67 - 0x7d	-	-reserved-
0x7e	B-1	ESCAPE
0x7f - 0xb9	-	-reserved-
0xba	B-1	SYNC
0xbb - 0xff	-	-reserved-

Formatted data string:

0xba, 0x01, 0x02, 0x37, 0x10, 0x02, 0x33, 0xFF,  
0x10, 0x00, 0x10, 0x00, 0x10, 0x02, 0x7e

*NOTE: The checksum is 0x10 and it is also followed by an ESC character.*

### B.2.3 FRAME ADDRESSING

All devices attached to the bus must be addressable via a broadcast address and a unique address. The addresses are allocated as follows:

Address	Addressee
0x00	Reserved
0x01	Subscriber Unit
0x02	External Device 1
0x03	External Device 2
0x04	External Device 3
0x05	External Device 4
...	External Device ...
0x07	External Device 6
0x08-0xA9	Reserved
0xAA	Broadcast Address
0xAB-0xFF	Reserved

The broadcast address is used by the Subscriber Unit at power-up to determine what devices are currently residing on the bus and to assign their respective addresses. The Subscriber Unit must select the lowest valid device address field (0x01) when it powers up.

### B.2.4 FRAME TYPES

The three frame types used in this protocol are as follows:

#### Command Frames

Command frames are used to directly command or request the destination to perform a specific function or operation. Commands include items such as setting protocol options, powering on or off, and changing operating modes.

Command frames are always responded to by an ACK or NAK message from the receiver and they cannot contain a broadcast destination address.

#### Event Frames

Event frames are used to indicate that certain events or conditions have occurred. The subscriber unit is the arbitrator of events. An event sent to the subscriber unit is a notification that the external device has had that event occur and the subscriber unit should take appropriate action. Events broadcast from the subscriber unit are notifications that the event has occurred and been arbitrated.

Event frames with a non-broadcast source and destination address are always responded to by an ACK or NAK message from the receiver. Broadcast event frames are never responded to by an ACK or NAK message.

#### Information Frames

Information frames contain non-event related data. These frames are generally sent by the subscriber unit and usually in response to an external device command frame.

Information frames are never responded to by an ACK or NAK message. If the message contains general radio state information, it has a broadcast destination address. If the message contains information relating to one or more parameters included in the command requesting the information, it has a specific destination address.

Note that with a command that is both responded to by an ACK message and causes an information frame to be generated, message ordering is arbitrary (the information frame may be sent before or after the ACK message).

### B.2.5 FRAME ACKNOWLEDGMENT

Only frames indicated can be acknowledged via the acknowledgment opcode. The acknowledgment must be received by the destination device within 500 milliseconds of reception. If the source device does not receive any response within the defined time, the source must retransmit the last message.

There are conditions under which a Command or Event message cannot be properly processed. In these cases, all devices must do one of the following:

- If the destination address was broadcast or was not the device's address, ignore the message.
- If the frame is an Information frame, ignore the message.
- If the frame is undefined or unsupported and the destination is the subscriber unit, respond with a NAK message containing the proper error code.
- If the frame is undefined or unsupported and the destination is an external device, ignore the message.
- If the frame is supported but processing it causes an error, respond with a NAK message containing the proper error code.

**ACK MESSAGE**

Function: This opcode is used by the destination device to signal the source device that the last transmission has been received and processed.

Destination Address Action: The last directed message transmitted may be deleted from the transmit buffer.

Origin: Any device on the bus.

Format:

<b>Opcode</b>
8 bits
0x0f

Data: None

**NAK MESSAGE**

Function: This opcode is used by the destination device to signal the source device that the last directed frame has been received and some type of problem has occurred.

Destination Address Action: The last directed message transmitted may be re-sent if the retry flag is on. If the retry flag is off, the message should be deleted from the transmit buffer and not retried.

Origin: Any device on bus

Format:

Opcode	Retry	Error Code	Rx Error
8 bits	1 bit	7 bits	8 bits
0x0e			

Data:

Retry:

- 0x0 The message should not be re-sent
- 0x1 The message may be re-sent

Error Code:

- 0x00 Message unsupported or undefined. See Rx Error which follows.
- 0x01 Bad parameter format
- 0x02 Parameter out of range
- 0x03 Unknown/unprogrammed bank, system or group
- 0x04 Feature disabled
- 0x05 Hardware failure detected
- 0x06 Power off denied
- 0x07 Table full
- 0x08 Table empty
- 0x09 Table entry not found
- 0x0a In wrong mode

Receive Error

This field is included only when the error code is 0x00. A zero value indicates an invalid opcode, and a non-zero value indicates that a receiver character error occurred and that the message was ignored.

**B.2.6 PACKET COLLISION**

This specification does not deal with packet collision recovery. In a multi-drop environment, the hardware or low level software drivers must prevent or detect collisions.

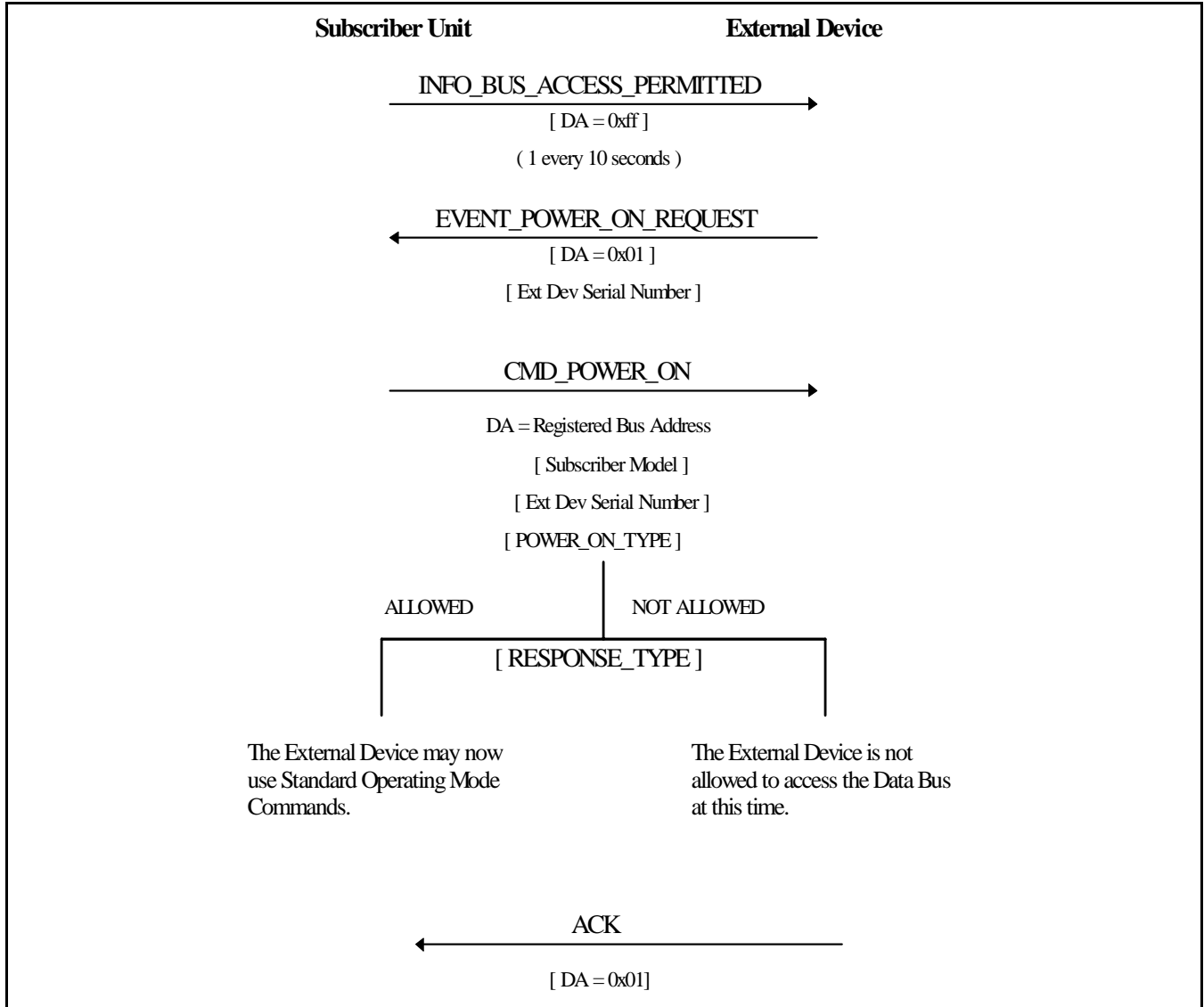

**Figure B-1 External Device Access To Subscriber Logic Controller**

### B.2.7 ERROR HANDLING

If any device on the control bus decodes a packet with an invalid checksum, the packet must be ignored. This protocol does not guarantee delivery of packets except where stated. It only guarantees that detectable corruption did not occur in the delivered packets.

### B.2.8 MULTIPLE FRAME SUPPORT

This protocol does not support multiple outstanding frames between the subscriber unit and any one external device. When a frame is sent that requires an ACK or NAK response, the source device should not send another until the first frame is prop-

erly acknowledged. However, each external device can have an outstanding ACK or NAK frame with the subscriber unit. Broadcast frames can be sent between directed frames in either direction.

## B.3 UNREGISTERED MODE

### B.3.1 INTRODUCTION

The “Unregistered” mode is the initial operating mode entered upon power up reset. When this mode is active, only a very limited set of messages are available. All external devices must negotiate with the subscriber logic controller before entering another mode.



The diagram in Figure B-1 shows the message flow for an external device to gain access to the subscriber logic controller.

### B.3.2 MESSAGE FORMATS

#### INFO BUS ACCESS PERMITTED

**Function:** This opcode is used to signal to External Devices that they may request access to the bus. After power up it is sent periodically over the data bus until an external device has registered. This is always a broadcast message.

**External Device Action:** If the External Device is UNREGISTERED:  
Upon reception of a BUS ACCESS PERMITTED, the External Device must respond with a POWER ON REQUEST message.

Otherwise, the message is ignored.

**Origin:** Subscriber unit

**Format:**

Opcode
1 byte
0x00

**Data:** None

#### EVENT POWER ON REQUEST

**Function:** This opcode is a request from the External Device for service from the Subscriber Unit in response to an INFO BUS ACCESS PERMITTED message. This message is valid only while the External Device is in the UNREGISTERED mode. For this message the source address is the broadcast address. The response to this message is CMD POWER ON and contains an assigned unit address. This message is one of the directed events that does not get acknowledged.

**Origin:** External Device

**Serial Number:** A variable length serial number that is returned in the CMD POWER ON.

**Format:**

Opcode	Serial Number
1 byte	0 to 16 bytes
0x02	

#### CMD POWER ON

**Function:** This opcode is sent from the Subscriber Unit in response to the EVENT POWER ON REQUEST made by an External Device.

**External Device Action:** Upon reception of a CMD POWER ON message, the unit must act as follows:

If Response Type = not allowed:

The External Device must remain in the “Unregistered Mode” and must wait until the next INFO BUS ACCESS PERMITTED message before attempting another EVENT POWER ON REQUEST message;

Otherwise, if Response Type = allowed:

the External Device must enter the “Standard Command Mode” and begin normal operation. The Response Type, if granted, indicates the radio configuration and assigns the external device’s bus address. **The External Device must transmit an acknowledge message upon reception.**

**Origin:** Subscriber Unit

**Format:**

Opcode	Response Type	Radio Model	Serial Number
1 byte	1 byte	8 bytes	0 to 16 bytes
0x03			

**Data:**

Response Type:

0x00 - Power On not allowed at this time  
0x01 - Power On allowed

**Radio Model:**

Eight printable ASCII bytes indicating the model identification. This is provided only when power on is allowed.

**Serial Number:**

A variable length serial number that was sent in the EVENT POWER ON REQUEST message. This is sent by data and high tier models, but not low or mid tier models.

**B.4 POWER DOWN MODE****B.4.1 INTRODUCTION**

The external device enters the Power Down mode when it needs to disconnect or power off. The subscriber logic controller also switches to this mode when it needs to power down or force the external device to shut down

The flowcharts of the various power-down events are as follows:

Event	Flowchart
Request Accepted	Figure B-2
Request Denied	Figure B-4
Broadcast Power Down	Figure B-3
Addressed Power Off	Figure B-5

**B.4.2 MESSAGE FORMATS****EVENT POWER OFF REQUEST**

**Function:** This is a request from an External Device to de-register and optionally power down the subscriber unit or from the subscriber unit to an external device to force a power down or disconnect. When the reason for power off is the power switch or idle time out, the subscriber unit de-registers the external unit and begins bus access messages. The subscriber unit does not power down. For any other reason, the subscriber unit only de-registers the requesting device and otherwise remains operational.

**Origin:** External device

**Format:**

Opcode	Reason
1 byte	1 byte
0x04	

**Data:****Reason:**

- 0x00 - Power switch
- 0x01 - Power down or idle time out
- 0x02 - Unit failure
- 0x03 - Disconnecting

**EVENT POWER OFF**

**Function:** This message from the subscriber unit logic board is used to tell the External Device if it can power down. This opcode can also be used to force a power down of the specified device/devices.

*NOTE: Reception of an EVENT POWER OFF may occur without a corresponding EVENT POWER OFF REQUEST such as when the user presses the power off button. It also may be a delayed power off as in the case of ignition sense time out.*

**External Device Action:** Upon reception of a properly addressed EVENT POWER OFF, if the External Device requested this through a power off request or the subscriber unit is powering down (see Action field in message), the External device must power down. If this is unsolicited, (a forced power-down) the External Device must become non-functional, and move to its unregistered mode. The unit may attempt registration again upon reception of an INFO BUS ACCESS PERMITTED message.

**Origin:** Subscriber unit logic board

**Format:**

Opcode	Action
1 byte	1 byte
0x05	



Data:

Action:

0x00 - Subscriber unit powering down

0x01 - Subscriber unit remaining operational

## B.5 STANDARD COMMAND MODE

### B.5.1 INTRODUCTION

This is the normal operating mode for the radio and external devices. There are two primary types of messages that are used in this mode. User Interface Messages control user displays or simulate user actions. These messages are used by a device such as a simple remote control unit.

The other type of messages are Operational Control messages. These messages directly control primary radio operations.

### B.5.2 USER INTERFACE MESSAGES

#### CMD RESET POWER UP

Function: This opcode indicates the receiving unit should execute a “power-up reset” including device registration.

Device Action: Initialize and disable all display fields to a power up default condition, change control state to UNREGISTERED.

Origin: Any device on bus

Format:

<b>Opcode</b>
8 bits
0x34

Data: None

#### CMD RESET WARM

Function: This opcode indicates that the receiving unit should execute a “warm reset” (soft reset).

Device Action: Initialize all display fields to active-idle and field controls to default settings. The control state remains REGISTERED.

Origin: Any device on bus

Format:

<b>Opcode</b>
8 bits
0x32

Data: None

#### CMD REQUEST BANK NAMES

Function: This opcode requests that the subscriber unit send a series of INFO BANK NAME messages enumerating all of the programmed bank names.

Origin: External device

Format:

<b>Opcode</b>
8 bits
0x36

Data: None

#### CMD REQUEST GROUP NAMES

Function: This opcode requests the subscriber unit to send a series of INFO GROUP NAME messages (see page B-19) enumerating all of the programmed groups in the current system.

Origin: External device

Format:

<b>Opcode</b>
8 bits
0x37

Data: None

**CMD REQUEST SOFTWARE VERSION**

Function: This opcode requests the subscriber unit to send an INFO SOFTWARE VERSION message indicating the current subscriber unit software version (see page B-20).

Origin: External device

Format:

<b>Opcode</b>
8 bits
0x39

Data: None

**CMD REQUEST SYSTEM GROUP**

Function: This opcode requests the subscriber unit to send an INFO SYSTEM GROUP message indicating the current subscriber unit bank, system, and group selections. If the subscriber unit is actively scanning, the returned information identifies the revert system and group.

Origin: External device

Format:

<b>Opcode</b>
8 bits
0x3a

Data: None

**CMD REQUEST SYSTEM NAMES**

Function: This opcode requests that the subscriber unit send a series of INFO SYSTEM NAME messages (see page B-21) indicating all of the programmed systems in the current bank.

Origin: External device

Format:

<b>Opcode</b>
8 bits
0x38

Data: None

**CMD UI NOTIFICATIONS**

Function: Directs the subscriber unit to asynchronously broadcast or not broadcast user interface notifications. This allows an external device that is acting as a remote control head to keep up-to-date with changes in the user interface display and user interactions with the subscriber unit.

Format:

Opcode	Flags
8 bits	2 bytes
0x3b	

Data:

**Flags:** Bit flags indicating the external device either wants the notification type (bit = 1) or does not want the notification type (bit = 0). On Subscriber Unit reset, all notifications are disabled. Refer to Table B-4 for more information.

**EVENT AUDIO GATE**

Function: This message requests the destination address to perform the requested audio muting or enabling specified in the message. Note that in the subscriber unit, muting and enabling are two separate logical gates (one physical gate) that maintain a request count. Muting has a higher priority than enabling, so if any mute requests are outstanding, the gate is muted.

When the mute request count goes to zero with any enable requests outstanding, the gate is unmuted. The subscriber unit arbitrates the mute and unmute requests so that when it sends an EVENT AUDIO GATE message, it only sends

Enable Gate (active/inactive) and not send Mute Gate events (see Data information which follows).

Origin: Subscriber unit or external device

Subscriber Unit Action: The indicated audio gate request count is modified and gate status may be changed.

Format:

Opcode	Enable	Gate
1 byte	1 bit	7 bits
0x40		

External Device Action: The indicated audio gate should be enabled or disabled.

**Table B-4 Command UI Notifications Flags**

Byte	Bit	Name	Events
1	7 (MSB)	AUDIO EVENTS	EVENT AUDIO GATE
	6	CHARACTER EVENTS	EVENT DISPLAY UPDATE - CLEAR CHARACTER FIELD LOAD CHARACTER FIELD WRITE CHARACTER FIELD
	5	CURSOR EVENTS	EVENT DISPLAY UPDATE - CURSOR POSITION CONTROL CURSOR UNDERLINE CONTROL SCANNING CURSOR INDICATOR
	4	DATA EVENTS	EVENT DATA ARQ ASSERTED EVENT DATA ARQ RELEASED EVENT DATA PTT PRESSED EVENT DATA PTT RELEASED
	3	DISPLAY EVENTS	EVENT DISPLAY UPDATE - DISPLAY ON DISPLAY OFF
	2	HOOK EVENTS	EVENT HOOK SWITCH
	1	ICON EVENTS	EVENT DISPLAY UPDATE - WRITE ICON FIELD WRITE BLINKING ICON FIELD
	0 (LSB)	INDICATOR EVENTS	EVENT DISPLAY UPDATE - WRITE INDICATOR FIELD
2	7 (MSB)	INPUT EVENTS	EVENT INPUT
	6	KEYPAD EVENTS	EVENT KEYPAD
	5	OUTPUT EVENTS	EVENT OUTPUT
	4	PTT EVENTS	EVENT PTT PRESSED EVENT PTT RELEASED
	3	ROTARY EVENTS	EVENT ROTARY
	2	SELECT EVENTS	EVENT BANK SELECT EVENT GROUP SELECT EVENT SYSTEM SELECT
	1	SOUND EVENTS	EVENT SOUND
	0 (LSB)	[reserved]	[set to zero]

Data:

Enable:

- 0x00 - Request gate to go inactive
- 0x01 - Request gate to go active

Gate:

- 0x00 - Mic Audio Mute Gate
- 0x01 - Mic Audio Enable Gate
- 0x02 - Rx Audio Mute Gate
- 0x03 - Rx Audio Enable Gate
- 0x04 - Speaker Audio Mute Gate
- 0x05 - Speaker Audio Enable Gate

**EVENT BANK SELECT**

Function: Directs subscriber unit to go to the indicated bank. The subscriber unit goes to the last selected system and group in that bank.

Format:

Opcode	Bank
8 bits	1 byte
0x41	

Data:

Bank:

Any valid bank index number obtained from an INFO BANK NAME message (see page B-19).

**EVENT DATA ARQ ASSERTED**

Function: This indicates that the Data ARQ signal is now asserted.

Origin: External Device

Format:

Opcode
1 byte
0x42

Data: None

**EVENT DATA ARQ RELEASED**

Function: Indicates that the Data ARQ signal is now released.

Origin: External Device

Format:

Opcode
1 byte
0x43

Data: None

**EVENT DATA PTT PRESSED**

Function: Indicates that the data PTT is currently asserted.

Origin: External Device

Format:

Opcode	Revert
1 byte	1 Byte
0x44	

Data:

- 0x00 = Same as DATA PTT input line
- 0x01 = Same as DATT PTT REVERT input line (see Section A.3.3).

**EVENT DATA PTT RELEASED**

Function: Indicates that the data PTT has been negated.

Origin: External Device

Format:

Opcode	Revert
1 byte	1 byte
0x45	

Data:

0x00 = Same as DATA PTT input line  
 0x01 = Same as DATA PTT REVERT input line  
 (see Section A.3.3).

**EVENT DISPLAY UPDATE**

Function: This is a command to update the current user interface indicators (LCD icons and LED indicators) and alpha display lines. Embedded subcodes control alphabet, scroll, and blinking modifiers.

External Device/Subscriber Unit Action: The indicated display field or field control must be updated on the display of the destination device. Some device displays may not be capable of particular subcodes. Such messages are then ignored.

Origin: Any device on bus

Data:

**Message structure:** The DISPLAY UPDATE opcode is followed by a one byte subcode field and 0 or more bytes of data. Each update message can contain only one subcode instruction.

Opcode	Subcode	Data Field
1 byte	1 byte	Variable bytes
0x07		

CLEAR CHARACTER FIELD

Function: This message clears the image in one specific ASCII field.

Device Action: Clear the indicated display field.

Format:

Subcode	Data
Clear Character Field	0x01/0x02
0x20	

Data:

0x01 - blank alpha line 1  
 0x02 - blank alpha line 2  
 0x00, 0x03-0xff - reserved

CURSOR POSITION CONTROL

Function: This message controls movement and application of the cursor character on the alpha-numeric display.

Device Action: Update the cursor location or on/off status.

Format:

Subcode	Data
Cursor Position	0x01 - 0x10
0x11	

Data:

0x00 - reserved  
 0x01 - 0x10 position cursor at the indicated character position 1-16 (position 1 = line 1 left most character, 16 = line 2 right most character)  
 0x11 - 0xff - reserved

CURSOR UNDERLINE CONTROL

Function: This message controls application of the underline cursor on the alpha display.

Device Action: Turn ON or OFF the underline cursor status.

Format:

Subcode	Data
Underline Action	0x00 - 0x01
0x12	

Data:

0x00 - disable underline cursor  
 0x01 - enable underline cursor  
 0x02 - 0xff - reserved



DISPLAY OFF

Function: This message disables the device display.

Device Action: Turn off the LCD display and all indicators.

Format:

<b>Subcode</b>
Display Off
0x00

Data: None

DISPLAY ON

Function: This message enables the device display.

Device Action: Enable the display and indicators. If a display image is present it is displayed.

Format:

<b>Subcode</b>
Display On
0x01

Data: None

LOAD CHARACTER FIELD

Function: This message updates the image to display in one specific ASCII field.

Device Action: Load the custom character bit map.

Subcode	Character	Data
Load character field	8-bit character number	Eight 8-bit map rows for character number
0x25		

Character: Eight custom characters may be defined. Character numbers are mapped from 0x00 to 0x07 and are repeated from 0x08 to 0x0f.

Data: The first data field is the top row of the 5 x 8 character block, the second field is the second row and so on.

SCANNING CURSOR INDICATOR

Function: This message controls the underline cursor which can be scanned across the alpha display line 1.

Device Action: Update the underline running cursor status.

Format:

Subcode	Data
Underline action	0x00 - 0x01
0x15	

Data:

0x00 - disable underline running cursor  
0x01 - enable underline running cursor

WRITE BLINKING ICON FIELD

Function: This message updates the icon field of the display device. Icons are bit mapped. A “1” in the bit map turns ON the blinking function for that icon, and a “0” turns OFF the blinking but leaves the icon ON.

Device Action: Modify the status of an icon by turning ON or OFF the BLINKING function for that icon using the bit map.

Format:

Subcode	Data
Write icon field	ICON MAP
0x31	16 bits

Data: Icon bit map (follows the LCD icon mapping artwork).

WRITE CHARACTER FIELD

Function: This message updates the image to display in one specific ASCII field.

Device Action: Write to the indicated display field the ASCII text.

Subcode	Data
Write character field	8 ASCII characters
Line1/Line2 0x21/0x22	

Data: Eight ASCII characters. Characters are mapped first character out to left most display position and fill to the right. Characters written past the right most display area are truncated. A single character written to the middle of the display area must be left justified with spaces by the subscriber unit.

### WRITE ICON FIELD

Function: This message updates the icon field of the display device. Icons are bit mapped. A “1” in the bit map indicates an active icon, and a “0” indicates an inactive icon.

Device Action: Modify the displayed icons.

Format:

Subcode	Data
Write Icon field	ICON MAP
0x30	16 bits

Data: Icon bit map (follows the LCD icon mapping artwork).

### WRITE INDICATOR FIELD

Function: This message updates the indicator field of the display device. Indicators have the property of color or intensity encoded in two bits.

Device Action: Modify the indicator field using the INDICATOR ACTION and bit map. The low two bits of the data field contain the indicator property (color or intensity).

Format:

Subcode	Data
Write indicator field	INDICATOR color/intensity
0x4x	8 bits

Subcode:

0x40 - Backlight (intensity)  
 0x41/0x43 - reserved (intensity)  
 0x45 - TX/BUSY indicator (color)  
 0x46 - 0x4f reserved

Data:

The bit pair assignment for color: 00 = off,  
 01 = Red, 10 = Green, 11 = Orange  
 The bit pair assignment for intensity: 00 = off,  
 01 = dim, 10 = mid, 11 = bright

### **EVENT GROUP SELECT**

Function: Directs subscriber unit to go to the indicated group in the currently selected system or notify external devices of a new group.

Format:

Opcode	Group
8 bits	1 byte
0x20	

Group: Any valid group index obtained from an INFO GROUP NAME message (see page B-19). Be sure to use the Group Index number and not the Group Display number or ID.

### **EVENT HOOK SWITCH**

Function: This indicates if the microphone is on-hook or off-hook.

Origin: Any device on bus

Format:

Opcode	On-Off
1 byte	1 byte
0x0c	

On-Off:

0x00 - off-hook  
0xFF - on-hook

**EVENT INPUT**

Function: This message indicates that one of the input lines has changed status. The data field indicates the current state of the lines. Some of the input lines are interrupt driven while others are polled. Therefore, depending on which line changes, not all transitions may be detected. A “1” indicates that the programmed input is in the active condition.

Origin: Subscriber unit

Format:

Opcode	Status
8 bits	8 bits
0x0b	

Status:

Input Line	Bit Set
Option 1	0
Input 2	1
Input 3	2

**EVENT KEYPAD**

Function: Indicates that the referenced button is pressed or released. The External Device must encode a valid debounced key pressed as well as a valid key release before indicating the next key down (n-key roll over not supported).

Origin: External Device

Format:

Opcode	Status	Event ID
8 bits	1 bit	7 bits variable
0x3f		

Data:

Status:

0x0 - key pressed  
0x1 - key released

Event ID:

0x00 - 0x0F Key/button event  
0x11 - 0x7F reserved

**EVENT OUTPUT**

Function: This message indicates that one of the output lines has changed status. The data field indicates that a state change has occurred on the line, not the current status of the line.

*NOTE: If Option 1 is programmed as an input, it does not appear in an Event Output message.*

Origin: Subscriber unit

Format:

Opcode	Status
8 bits	1 byte
0x06	

Status:

Output Line	Status Set	Status Clear
Option 1	01	00
Output A	A1	A0
Output B	B1	B0
Output C	C1	C0
Output D	D1	D0
Output E	E1	E0
Output F	F1	F0

**EVENT PTT PRESSED**

Function: This indicates that the PTT is currently asserted. The event input to generate this message is design specific.

Origin: External Device

Format:

Opcode
1 byte
0x09

Data: None

**EVENT PTT RELEASED**

Function: Indicates that the PTT has been negated. The event input to generate this message is design specific.

Origin: External Device

Format:

Opcode
1 byte
0x0a

Data: None

**EVENT ROTARY**

Function: This indicates that the rotary switch has had its value changed.

Origin: Any device on bus.

Format:

Opcode	Type
8 bits	1 byte
0x50	

Type:

Relative:

0 through 63: 0x00 through 0x3f  
-1 through -64: 0x7f through 0x40

0x80 through 0xff are reserved

**EVENT SOUND**

Function: This indicates that the destination unit should provide the specified audio alert sound. There are several internal conditions that can cause the subscriber unit to internally stop a sound or honk cycle. Only those events that stop a continuous operation are sent as event notifications from the subscriber unit.

Origin: Any device on bus.

Format:

Opcode	Type
8 bits	1 byte
0x46	

Type:

0x00 - Stop any active sound or horn honk  
0x01 - Start intercept tone  
0x02 - Start busy tone  
0x03 - Start horn honk cycle  
0x04 - Sound ring tone once  
0x05 - Sound beep tone once  
0x06 - Sound loud beep tone once

**EVENT SYSTEM SELECT**

Function: Directs the subscriber unit to go to the system indicated by the system index number of the currently selected bank. This message also notifies the external device when a new system is selected. The subscriber unit goes to the last selected group in that system.

Origin: Any device on the bus.

Format:

Opcode	System
8 bits	1 byte
0x47	

System: Any valid system index number in the currently selected bank. This number is from the INFO SYSTEM NAME message described on page B-21.

## EVENT VOLUME SET

*NOTE: This function is available only with data models of this transceiver.*

Function: Sets and stores the volume level to the specified value or returns the current volume setting. A number of 0-63 sets the volume level, and a number of 128 or greater returns the current setting.

Origin: Any device on the bus.

Format:

Opcode	Volume
1 byte	1 byte
0x0d	0-63

Volume:

Set: 0 = minimum, 63 = maximum  
Return Current Level: 128 or greater

## INFO BANK NAME

Function: This message is sent in response to the CMD REQUEST BANK NAMES message described on page B-10. It indicates the displayed alpha tag of one of the programmed banks. One message is sent for each programmed bank.

Origin: Subscriber unit

Format:

Opcode	Bank Index No.	Total No. of Banks	Display Alpha Tag
8 bits	1 byte	1 byte	8 bytes
0x60			

Data:

Bank Index: Indicates the bank number in the series. For example, if there are four banks total, four messages are sent with index numbers 1-4.

Total Banks: Total number of banks programmed.

Name: Alpha tag assigned to this bank (space padded on right).

## INFO GROUP NAME

Function: This message is sent in response to the CMD REQUEST GROUP NAMES message described on page B-10. It indicates the display number and alpha tag of each group programmed in the current system. One message is sent for each programmed group.

Format:

Opcode	Group Index No.	Total No. of Groups	Display No.	Display Alpha Tag
8 bits	1 byte	1 byte	1 byte	8 bytes
0x61				

Data:

Group Index No.: Indicates the group number in the series. For example, if there are four groups total in the current system, four messages are sent with index numbers 1-4.

Total Number of groups: Number of groups programmed in the current system.

Display No.: The number that is displayed when the group is selected.

Display Alpha Tag: The alpha tag that is displayed when the group is selected (space padded on right).

**INFO SOFTWARE VERSION**

Function: This message is sent in response to the CMD REQUEST SOFTWARE VERSION message described on page B-11. It indicates the current software version of the subscriber unit.

Format:

Opcode	Major	Minor	Alpha
8 bits	1 byte	1 byte	8 bytes
0x62			

Data:

Major: The software version is indicated as “2xx” with “xx” the revision number. The Major No. should always be “2”.

Minor: This is the “xx” number just described.

Alpha: This is the “003x2xx0” number displayed when the test mode is selected (see Section 3.12.4).

**INFO SYSTEM GROUP**

Function: This message is sent in response to the CMD REQUEST SYSTEM GROUP message described on page B-11. It indicates the bank, system, and group currently selected by the subscriber unit. If the subscriber unit is actively scanning, the returned information reflects the revert system and group. The Options field indicates the options programmed for the group. These options may be enabled or disabled by the menu mode or a front panel option switch.

Origin: Subscriber unit

Format:

Opcode	Bank Index No.	System Index No.	Group Index No.
8 bits	1 byte	1 byte	1 byte
0x63			

Encode ID	Decode ID	Group Options	Alpha Tag
1 byte	1 byte	1 byte	8 bytes

Data:

Bank Index No.: The series number of the current bank (see preceding INFO BANK NAME message).

System Index No.: The series number of the current system (see following INFO SYSTEM NAME message).

Group Index: The series number of the current group number within the system (see preceding INFO GROUP NAME message).

Encode ID: The group encode ID when group is from a trunked (Multi-Net/LTR) system. This field is zero when group is from a conventional system.

Decode ID: The group decode ID when group is from a trunked system. This field is zero when group is from a conventional system.

Options: The current group options from a bit field as follows:

Bit	Description
7 (MSB) - 5	[reserved]
4	Trunking System
3	Voice Group
2	Encrypted
1	Call Light
0 (LSB)	Horn Honk

Alpha Tag: The programmed group alpha tag (if any), space padded on right.

**INFO SYSTEM NAME**

Function: This message is sent in response to the CMD REQUEST SYTEM NAMES message described on page B-11. It indicates the display number and alpha tag of each system programmed in the current bank. One message is sent for each system in the bank.

Format:

Opcode	System Index No.	Total No. of Systems	Display No.	Display Alpha Tag
8 bits	1 byte	1 byte	1 byte	8 bytes
0x64				

Data:

System Index No.: Indicates the system number in the series. For example, if there are four systems total in the current bank, four messages are sent with index numbers 1-4.

Total No. of Systems: Total number of systems programmed in the current bank.

Display No.: The number that is displayed when the system is selected.

Display Alpha Tag: The alpha tag that is displayed when the system is selected.

**B.5.3 OPERATIONAL CONTROL MESSAGES**

**CMD SET USER SQUELCH**

Function: Requests the current squelch level or sets the subscriber unit squelch to the specified level. Squelch levels may vary from 1 to as high as 255. The command is NAKed if the subscriber unit is scanning or not currently using conventional signaling.

Format:

Opcode	Squelch
1 byte	1 byte
0x28	

Squelch:

0 = Requests that the subscriber unit user squelch setting be returned. The subscriber unit returns this setting as a broadcast message and also ACKs the request. The order of the ACK and returned broadcast message is not guaranteed.

1-255 - Sets the subscriber unit squelch to this level. An ACK is returned if the value is within the limits determined by information that was stored in the transceiver during tuning. Otherwise, it is NAKed. The change is saved in memory in the Standard Command Mode, but not in the Remote Command Mode described in Section B.6.

**CMD BLOCK DECODE**

Function: Directs the subscriber unit to enable or disable block decode. Note that this is a radio-wide operation, not system specific. On subscriber unit reset, block decode is enabled.

Format:

Opcode	Enable
1 byte	1 byte
0x3c	

Data:

Enable:

- 0x00 - Disable block decoding
- 0x01 - Enable block decoding

**CMD CLEAR LOCKOUT GID**

Function: Directs the subscriber unit to clear a “locked out” block decode system and group ID code. Note that if only a system number is specified, all lockouts in that system are cleared. If no system and group are specified, all lockouts are cleared.

Format:

Opcode	System	Group
1 byte	1 byte	1 byte
0x3d		

Data: See CMD SET LOCKOUT GID which follows for the format.

**CMD GET LOCKOUT GID**

Function: Directs the subscriber unit to return an INFO LOCKOUT GID message containing all currently “locked out” block decode system and group IDs.

Format:

<b>Opcode</b>
1 byte
0x3e

Data: None

**CMD RADIO NOTIFICATIONS**

Function: Directs the subscriber unit to asynchronously broadcast or not broadcast radio control notifications. This allows an external device that is sending or receiving data over-the-air to keep up-to-date with changes in the subscriber unit state.

Format:

Opcode	Flags
8 bits	Bits
0x51	

Data:

Flags: Bit flags indicate if the external device wants the notification type (bit = 1) or does not want the notification type (bit = 0). On Subscriber Unit reset, all notifications are disabled.

Bit	Name	Description
7 (MSB)	CALL EVENTS	EVENT CALL
6	SCAN EVENTS	EVENT SCAN
5	TRANSMIT EVENTS	EVENT TRANSMIT
4 - 0 (LSB)	Reserved	Must be zero

**CMD GET RADIO STATUS**

Function: Direct subscriber unit to send an INFO RADIO STATUS message.

Format:

<b>Opcode</b>
1 byte
0x52

Data: None

**CMD SET LOCKOUT GID**

Function: Directs the subscriber unit to “lock out” a block decode system and group ID. When block decoding is active and a block decode call is received on the specified system and group, the call is ignored. Note that on a change of banks, all lockouts are cleared. Up to 16 system/group combinations may be locked out at any time.

Format:

Opcode	System Index No.	Group Index No.
1 byte	1 byte	1 byte
0x53		

Data:

System Index No.  
 0x00 - Reserved  
 0x01 to 0x81 - System index number in current bank  
 0x82 to 0xFE - Reserved  
 0xFF - Any system (lockout the group in any system in bank)

Group Index No.  
 0x00 - Reserved  
 0x01 to 0xFE - Group decode ID to lockout  
 0xFF - Lockout all block decode IDs in specified system



**CMD SET GID**

**Function:** Overrides the current group encode and decode IDs and changes them to the values in the data field. On a trunking system (LTR or Multi-Net), this sets the over-the-air IDs. On a conventional system, it is ignored.

**Format:**

Opcode	Tx ID	Rx ID
1 byte	1 byte	1 byte
0x54		

**Data:**

**Tx ID** - Sets the transmit encode ID; zero releases the override

**Rx ID** - Sets the receive decode ID; zero releases the override

**EVENT CALL**

*NOTE: This message is supported only by transceivers which have revision 208 or later Flash software.*

**Function:** Provides a notification from subscriber unit that the specified call event has occurred.

**Format:**

Opcode	Event	System Index No.	Group Index No.	Unique ID
1 byte	1 byte	1 byte	1 byte	2 bytes
0x48				

**Data:**

**Event:**

Bit	Description
7 (MSB) - 6	[reserved]
5	Call Start (1 = call received, 0 = call ended)
4	Voice (1= voice call, 2=data call)

Bit	Description
3	Trunked (1= trunked call, 0 = conventional call)
2 - 0 (LSB)	Priority: 0x0 = block decode (trunked only) 0x1 = group scan 0x2 = [reserved] 0x3 = last selected 0x4 = [reserved] 0x5 = priority 2 0x6 = priority 1 0x7 = all call (Multi-Net only)

**System Index No.:**

System index number on which the call was received (only sent when a valid call is received). *NOTE: Refer to INFO SYSTEM NAME message description on page B-21 for more information on system index numbers.*

**Group Index No.:**

For call end - Not sent

For voice or data call - Conventional = Index of group on which the call was received;  
Trunked = group decode ID.

For block decode - Group decode ID

*NOTE: Refer to INFO GROUP NAME message description on page B-19 for more information on group index numbers.*

**Unique ID:**

Included on Multi-Net systems only, for any call received event

**EVENT SCAN**

**Function:** Provides a notification from the subscriber unit that the specified scan event has occurred. In addition, if the message is from the external unit, it provides commands that set the scanning type. Group scanning may be disabled on a per system basis by personality programming. Therefore, setting the scan type may not enable scanning. The scan type cannot be changed while the subscriber unit is scanning.

Format:

Opcode	Event
1 byte	1 byte
0x49	

Data - Event:

Event	Description
0x00	Scanning has stopped or set scan type to "None"
0x01	Group scanning started or set scan type to "Group Only".
0x02	System and group scanning started or set scan type to "System and Group".

## EVENT TRANSMIT

Function: Provides a notification from the subscriber unit that the specified transmit event has occurred.

Format:

Opcode	Event
1 byte	1 byte
0x4a	

Data - Event:

0x00 - End transmit  
 0x01 - Start voice transmit  
 0x02 - Start data transmit  
 0x03 - Transmit failed - channel busy  
 0x04 - Transmit failed - out of range  
 0x05 - Transmit failed - disabled

**Table B-5 INFO RADIO STATUS Conditions**

Byte	Bits	Name	Description
0	7 (MSB)	SCAN ENABLED	Scanning is enabled
	6	ENCRYPT ENABLED	Encryption is enabled
	5	COMPAND ENABLED	Companding is enabled
	4	TRANSMIT	Radio is transmitting
	3	PHONE GROUP	Radio is on an interconnect group
	2	HANDSHAKE	Radio is attempting system access
	1,0 (LSB)	SCAN TYPE	Type of scanning (when enabled): 0x0 = Disabled 0x1 = Group Only 0x2 = System/Group
1	7 (MSB)	RX DATA CALL	Radio is receiving a valid data call
	6	RX VOICE CALL	Radio is receiving a valid voice call
	5	TRUNKED	Radio is on a trunked system
	4	SCAN SELECT	System scan select type: 0x0 = Single Site 0x1 = Multi Site
	3	SPEAKER AUDIO ENABLED	Speaker gate is active
	2	RX AUDIO ENABLED	Rx Audio gate is active
	1	MIC AUDIO ENABLED	Mic Audio gate is active
0		[reserved]	

## INFO LOCKOUT GID

**Function:** Contains a list of the “locked out” block decode system and group IDs.

### Format

Opcode	System	Group	---	System	Group
1 byte	1 byte	1 byte	---	1 bytes	1 byte
0x48					

**Data:** Variable length list of system and group numbers. See CMD SET LOCKOUT GID description on page B-22 for a definition of system and group values.

## INFO RADIO STATUS

**Function:** Contains a summary of the current radio status. System and group bytes are sent only if the subscriber unit is active in a receive or transmit call.

### Format:

Opcode	Flags	System Index No.	Group Index No.
1 byte	Bits	1 byte	1 byte
0x66			

### Data:

Flags: See Table B-5.

#### System Index No.:

Index number of the revert system or the system on which the call was received (this is sent only when a valid call is received). *NOTE: Refer to INFO SYSTEM NAME message description on page B-21 for more information on system index numbers.*

#### Group Index No.:

For call end - Not sent  
 For voice or data call - Conventional = Index of revert group or the group on which the call was received; Trunked = Group decode ID.  
 For block decode - Group decode ID

*NOTE: Refer to INFO GROUP NAME message description on page B-19 for more information on group index numbers.*

## B.6 REMOTE COMMAND MODE

### B.6.1 INTRODUCTION

The Remote Command Mode is a method by which a single external device can take almost complete control of the subscriber unit. This mode disables most subscriber unit processing and then forces the subscriber unit into a “conventional” mode with parameters set by the external device. Personality programming also has the option of forcing the subscriber unit into this mode at start-up.

Remote Command Mode does not support multi-drop operation and it is the responsibility of the external device to not send commands that cause the subscriber unit to violate FCC rules and regulations.

The following is a list of Standard Command Mode messages that are also valid in Remote Command Mode. The page on which each of these commands is described is indicated in parentheses.

CMD SET USER SQUELCH (B-21)  
 CMD REQUEST SOFTWARE VERSION (B-11)  
 CMD RESET WARM (B-10)  
 CMD RESET POWER UP (B-10)  
 EVENT AUDIO GATE (B-11)  
 EVENT DISPLAY UPDATE (B-14)  
 EVENT SOUND (B-18)  
 EVENT TRANSMIT (B-24)  
 EVENT VOLUME SET (B-19)  
 INFO SOFTWARE VERSION (B-20)

The following list of Standard Command Mode events may be generated by the subscriber unit but not by the remote control unit when in Remote Command Mode:

EVENT KEYPAD (B-17)  
 EVENT ROTARY (B-18)

In remote command mode all EVENT MESSAGES from the subscriber unit are sent as broadcast events and therefore are not acknowledged by the external device.

## B.6.2 COMMAND MESSAGES

### CMD ENTER REMOTE MODE

**Function:** Requests that the subscriber unit switch to the remote command mode. No other external devices should be connected or registered when this message is sent. If any are or if the external bus is in multi-drop mode, a NAK message response is sent.

If the subscriber unit is personality programmed for “remote mode only” operation, this message is sent as a broadcast (unacknowledged) message when subscriber unit start-up is completed. The remote device does not have to register and should just assume device address 0x02.

**Format:**

Opcode
1 byte
0x21

**Data:** None

### CMD EXIT REMOTE MODE

**Function:** Requests that the subscriber unit switch to the standard command mode. The subscriber unit will attempt to resume normal operation. This command causes a “warm” restart of the subscriber unit. On restart, no external devices are considered to be registered. If this command is sent and the subscriber unit has been programmed for “remote command mode” only operation, a power on reset is performed and remote command mode is restarted.

**Format:**

Opcode
1 byte
0x22

**Data:** None

### CMD REMOTE NOTIFICATIONS

**Function:** Requests that the subscriber unit switch to the remote command mode. All other external devices are commanded to perform a directed power down disconnect before this message is acknowledged. If the subscriber unit is personality programmed for “remote mode only” operation, this message is sent as a broadcast (unacknowledged) message when subscriber unit start-up is complete.

**Format:**

Opcode	Flags	Conv Rate
1 byte	1 byte	1 byte
0x23		

**Data:**

**Flags:**

Bit flags indicating the external device wants the notification type (bit = 1) or does not want the notification type (bit = 0). On Subscriber Unit reset, all notifications are disabled (see Table B-6).

**Conv Rate:** Analog to Digital conversion rate. Set the time between INFO A TO D messages in ~250 millisecond intervals. If set to zero, INFO A TO D messages are not sent.

### CMD SET CALL GUARD

**Function:** Commands the subscriber unit to set the requested Call Guard code. Call Guard values are octal encoded. Digital Call Guard settings are already encoded this way. For tone Call Guard squelch, the Call Guard table entry number (see Call Guard table at end of Section 4), must be converted into an octal number.

**Format:**

Opcode	Tx Call Guard Code	Rx Call Guard Code
1 byte	1 byte	1 byte
0x24		

**Table B-6 COMMAND REMOTE NOTIFICATIONS Flags**

Bit	Name	Events
7 (MSB)	REMOTE CALL EVENTS	EVENT CALL DETECTED EVENT CALL LOST
6	REMOTE TRANSMIT EVENTS	EVENT TRANSMIT
5	REMOTE AUDIO EVENTS	EVENT AUDIO GATE
4	REMOTE DISPLAY EVENTS	EVENT DISPLAY UPDATE
3	REMOTE KEYPAD EVENTS	EVENT KEYPAD
2	REMOTE SOUND EVENTS	EVENT SOUND
1	REMOTE ROTARY EVENTS	EVENT ROTARY
0 (LSB)	[reserved]	must be zero

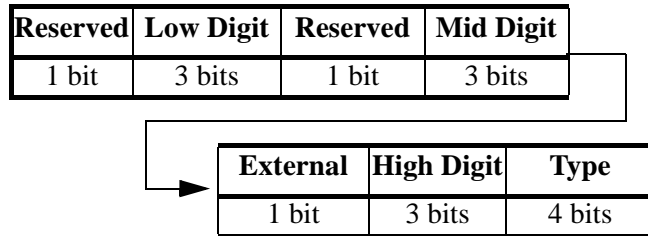
Call Guard Byte Format:Data:

## Call Guard type:

- 0x00 - No Call Guard squelch
- 0x01 - Tone Call Guard squelch
- 0x02 - Digital Call Guard squelch
- 0x03 - Inverted digital Call Guard squelch
- 0x04 - 0x0f - reserved, do not use

High Digit: High order octal digit of Call Guard value

External: Indicates if external Call Guard line must also be detected

Mid Digit: Middle octal digit of Call Guard value

Ext Active: Indicates external Call Guard squelch active state (high or low)

Low Digit: Low order octal digit of Call Guard value

Reserved: Reserved, must be set to zero

**CMD SET FREQ**

Function: Requests that the subscriber unit switch to the requested transmit and receive frequencies. The frequency value is expressed in 1.25 KHz units and can be calculated as follows:

$$\text{Desired Frequency (in Hz)} \div 1250$$

The current platform is only capable of locking on 6.25 KHz channels. Therefore, attempting to set a frequency that is not divisible by 6.25 KHz causes a parameter error to be returned.

Format:

Opcode	Tx Freq	Rx Freq
1 byte	4 bytes	4 bytes
0x25		

Data: Tx & Rx Freq - Transmit and receive frequencies in 1.25 kHz units. Send MSB first.

**CMD SET IF BANDWIDTH**

Function: Requests that the subscriber unit select the requested I/F bandwidth. The protocol supports two bandwidth settings; however, some units may only allow one.

Format:

Opcode	Bandwidth
1 byte	1 byte
0x26	

Bandwidth: I/F bandwidth:

- 0x00 - Narrow
- 0x01 - Wide

### CMD SET POWER LEVEL

Function: Requests that the subscriber unit select the requested RF power level. The protocol supports five power settings; however, some units may only allow two in which case all “low” settings are the same. The exact power level for each is set by radio tuning.

Format:

Opcode	Power
1 byte	1 byte
0x27	

Power: RF Power Level-

- 0x00 - High
- 0x01 - Low Power Setting 1
- 0x02 - Low Power Setting 2
- 0x03 - Low Power Setting 3
- 0x04 - Low Power Setting 4

### CMD START TX

Function: Requests that the subscriber unit begin transmitting. If the TRANSMIT EVENTS notification is enabled, an EVENT TRANSMIT message is sent. Normally, the subscriber unit does not transmit on a busy channel (squelch is open). However, a transmit condition may be forced by setting the force option on.

Format:

Opcode	Force
1 byte	1 byte
0x29	

Force transmit:

- 0x00 - Transmit only if channel is not busy (squelch closed)
- 0x01 - Transmit always

### CMD STOP TX

Function: Requests that the subscriber unit stop transmitting.

Format:

Opcode
1 byte
0x2a

Data: None

### CMD SET SQUELCH CIRCUIT

Function: Sets the value that is output to shift register U305 to control the trip point of a comparator in the squelch circuit. Squelch levels may vary from 1 to as high as 255. The command is NAKed if the subscriber unit is scanning or not currently using conventional signaling. The change is not saved in memory.

Format:

Opcode	Squelch Circuit
1 byte	1 byte
0x2f	

Squelch Circuit:

0 = This is an invalid level. The command is NAKed if it is used.

1-255 - Valid squelch circuit levels. The command is ACKed.

## APPENDIX C REVISION SUMMARY

### C.1 OPERATING SOFTWARE REVISIONS

The operating (Flash) software version can be determined as described in Section 3.12.4. The following is a summary of changes made for recent revisions:

#### Version 210 - Released 9/99 For Low/Mid/High/Data Tier Models

- With high and data tier models, corrected an error in a serial interface message relating to display information.
- With low and mid tier models, corrected a problem with displaying the software revision number.

#### Version 209 - Released 8/99 For Low/Mid/High/Data Tier Models

- Change squelch operation to use RSSI signal as well as noise signal (similar to LTR-Net models). This capability is available only with versions that have the revised squelch circuit (see Section C.4). The software automatically detects a revised transceiver from a marker in the logic that indicates that the radio has the change. If this marker is not present, it is assumed that it has the unrevised squelch circuit and the standard squelch algorithm is used.
- Made serial interface updates and enhancements
- Added support for channel tables 2 and 3 in LTR and conventional systems (high and data tier only)

#### Version 208 - Released 6/99 For Low Tier Models Only

- Increased squelch adjust range during conventional operation
- Corrected minor problems

#### Version 207 - Released 5/99 For Low/Mid/High/Data Tier Models

- Changed lamp test to display software version (low tier only)
- Corrected several serial/data interface problems
- Corrected other minor problems

*NOTE: A 128K Flash ROM (U108) is required to run Version 207 or later software. All models are equipped with this device except some early mid tier models*

#### Version 206 - Released 9/98

- Corrected several minor problems

### C.2 PROGRAMMING SOFTWARE REVISIONS

*NOTE: If possible, always use the latest programming software available.*

Recent revisions to the programming software described in Section 4 are as follows. The version number is indicated on the top of most screens.

#### Version 209 - Released 8/99

- Added capability to set the volume level of data models
- Changed ignition sense delay default to “Forever”
- Added warning messages in “Edit Banks” screen

#### Version 208 - Released 6/99

- Added capability to program data models
- Added function to display electronic warranty information by pressing the F7 key (see Section 4.5.1)
- Added function to display tier and software version information during upload (see Section 4.5.5)
- Corrected minor problems

#### Version 206 - Released 5/99 (207 was skipped)

- Added ability to program LTR-Net upgradable transceivers. Previous versions of the programmer returned a type error when attempting to program one of those models. Refer to Section C.4 for more information on LTR-Net upgradability.
- Corrected minor problems

#### Version 205 - Released 2/99

- Added capability to program 470-512 MHz UHF models

### C.3 TUNING SOFTWARE REVISIONS

The operation of the tune software is described in Section 7. Recent revisions to this software are as follows:

**Version 203** - Released 8/99

- Added the capability to tune the RSSI-enhanced squelch used by transceivers having the upgraded squelch circuit and running Version 209 or later software (see Sections C.1 and C.4).

*NOTE: This version or later must be used to tune upgraded transceivers running operating software Version 209 or later (see Sections C.1 and C.3)*

**Version 202** - Released 3/98

- Added capability to tune 800 and 900 MHz models

### C.4 REVISION LETTER CHANGES

#### 3.4.1 GENERAL

The transceiver revision letter is changed whenever a major hardware or software change occurs. The revision letter is part of the transceiver identification number described in Section 1.4. Each 98xx model can have a unique revision letter, and the part numbers used to identify the various models are described in Section 1.3.

#### 3.4.2 SQUELCH CHANGE

Table C-1 lists the revision letter change that occurred when hardware and logic changes were made that allowed an improved squelch algorithm to be used. This algorithm utilizes both noise and RSSI signals similar to LTR-Net models, and is used if the transceiver has these hardware changes and Version 209 or later operating software (see Section C.1).

*NOTE: To tune an upgraded transceiver running Version 209 or later operating software, tuning software Version 203 or later, must be used (see Section C.3).*

The following are the squelch and RSSI circuit changes that occurred when the revision letter change in Table C-1 occurred:

#### Audio/Logic Board Changes

- C304 - .22μF to .033μF
- R300 - 15k to 6.8k
- R301 - 10k to 4.7k
- R302 - 1k to 680
- R305 - 270k to 390k
- R307 - 10k to 5.6k
- R310 - 270k to 150k
- R143 - 1k to 2.7k
- R161 - 10.5k to 24.3k
- R197 - 10k (added)

#### RF Board Changes

- R258 - 3.3k to 10k
- C303 - .01μF to .33μF

### 3.4.3 LTR-NET UPGRADABLE MODELS

With high tier models only, the revision letter change in Table C-1 also indicates which transceivers are field upgradable to LTR-Net operation. Earlier models can also be upgraded, but they must be returned to the factory for the squelch circuit and logic changes. Field upgrading is performed using special software and keys purchased from the E.F. Johnson Company. Low tier models are not capable of LTR-Net operation and therefore are not field upgradable.

**Table C-1 Revision Letter of Upgraded Models**

Model	Revision Letter	Model	Revision Letter
9841-232	J	9881-203	D
9841-233	F	9881-802	C
9841-252	J	9883-202	E
9843-232	D	9883-203	E
9843-233	D	9894-202	D
9843-252	K	9894-203	D
9843-253	J	9896-202	D
9881-202	D	9896-203	D

**NOTES:**  
 1. The model is indicated by the last seven digits of the transceiver part number (see Section 1.3).  
 2. Models with the above revision letter or later have been upgraded.



### C.5 ADDITIONAL CHANGES MADE SINCE LAST PRINTING

The following is a summary of the main changes that have been made to this manual since the last printing in September 1999.

#### 2.8 KEY CAP KITS

The key cap kits have changed to the following:

Key Cap Kit, Part No. 587-9840-001, is standard with each LTR transceiver and includes the five caps indicated below.

<b>FCN</b>	<b>SCAN</b>	<b>A/D</b>	<b>TA</b>	<b>AUX</b>
------------	-------------	------------	-----------	------------

An optional key cap kit, Part No. 587-9840-004, is also available which includes all of the caps in the following list:

<b>FCN*</b>	<b>SCAN*</b>	<b>A/D*</b>	<b>ROAM*</b>	<b>TEL*</b>
<b>TA</b>	<b>AUX</b>	<b>HOME</b>	<b>PAGE</b>	<b>HORN</b>
<b>C/G</b>	<b>PRI</b>	<b>USR1</b>	<b>USR2</b>	<b>MON</b>
<b>CPND</b>	<b>MHNG</b>	<b>STLH</b>	<b>MICPA</b>	<b>BANK</b>
<b>EMER</b>	<b>ENCPT</b>	<b>Rx PA</b>	<b>CALL</b>	
<b>(Blank)</b>	<b>(Blank)</b>			

To remove a key cap, insert a tool with a sharp tip in the slot on the bottom of the cap and carefully pry against the front panel to release the cap.

### SECTION 3 OPERATION

#### 3.4.5 SELECTING SYSTEMS AND GROUPS

The last sentence in this section was changed to read:

When "0" is programmed, the transceiver remains in the last selected mode until power is cycled. The default mode is then selected.

#### 3.8 LTR FEATURES

##### Receive-Only Groups

Receive-only groups are available with LTR operation as well as conventional operation. To

program a receive-only LTR group, simply select an encode ID of "0".

#### 3.8.3 RECEIVE PRIORITY ID CODES

##### Transmit Disable On Block IDs

Each bank can now be programmed so that transmitting is inhibited while a call is being received on a block ID code. This operation is selected on the Create/Edit Bank screen by programming "Inhibit Transmit During Block Decode = Yes". The transmitter can be keyed immediately after the call is complete (there is no 5-second delay as with the transmit inhibit feature). When this parameter is programmed "No", the transmitter can be keyed while receiving a call on a block ID. This feature is available with operating (Flash) software Version 211 or later, and programming software version 210 or later.

### SECTION 4 PROGRAMMING

#### TABLE 4-1 Main Radio Parameters Screen (Page 4-19)

##### New Volume Set Parameter

A new "Digital Volume" parameter has been added under the status definitions. TABLE 4-2 Create/Edit Bank Screen Parameters Screen (Page 4-21)

##### New Inhibit Transmit On Block IDs Parameter

A new parameter has been added to automatically disable the transmitter while receiving a call on a block ID. This parameter is called "Inhibit Tx During Block Decode" on the Create/Edit Bank screen. Refer to Section 3.8.3 for more information.

### SECTION 7/8 PARTS LIST/SCHEMATICS

##### New 430-470 MHz RF Board

A revised 430-470 MHz RF board is now shipping. This new board has the same parts layout as the 470-512 MHz version. However, there are many part value changes, so a new parts list and schematic diagram are included.

430-470 MHz 40W PA Board Changes

The following changes have been made to this board. A new revised schematic is included.

- Added a stabilization module, Part No. 023-9800-531, across the base-collector of Q600. This module contains the following components:
 

C1	0.01 $\mu$ F X7R $\pm$ 10% 50V	510-3606-103)
R1	33 ohm $\pm$ 5% 1W smd	569-0175-330
R2	33 ohm $\pm$ 5% 1W smd	569-0175-330
- Changed:
  - C617 from 43 to 47 pF (510-0019-470)
  - C637 from 15 to 18 pF (510-0019-180)
  - C657 from 7.5 to 15 pF (510-3663-150)
  - L607 from 9T to 7T (542-0030-007)
  - R606 from 68k to 100k (569-0105-104)
  - R607 from 100k to 75k (569-0105-753)
  - R612 from 51 to 330 (569-0175-331)
- Added across L601:
  - R614, 330 ohm (569-0175-331)
  - R615, 330 ohm (569-0175-331)
  - R616, 330 ohm (569-0175-331)

470-512 MHz 40W PA Board Changes

The following changes have been made to this board.

- Changed C615 from 56 to 47 pF (510-0019-470)
- Added across C644, C658, 4.7 pF (510-3601-479)

800/900 RF Board Changes

The following changes have been made to this board.

- On the schematic, the part number under “Q508” (left center) was incorrect. Changed “1300” to “3612”.
- With 800 MHz versions only, C202 has changed from 11 to 12 pF (510-3615-120).

900 MHz 15W and 30W PA Board Changes

The following changes have been made to these boards.

- With 30W models, the last three digits of the part number for Stabilization Board A533 have changed from -533 to -531.
- Added across C603/C604, C640, 2.2  $\mu$ F (510-2245-229).
- Added RF shield 537-5001-008 on bottom of PC board near C604/C605.

800 MHz 30W PA Board Changes

The following changes have been made to this board.

- Changed C633 from 12 to 56 pF (510-3653-560)
- Changed R601 from 0.015 to 0.030 ohm (569-2019-307)
- Added across base-emitter of Q651, R614, 100 ohm (569-0175-101)
- Added across L602, R615, 330 ohm (569-0175-331)

Audio/Logic Board Changes

The following change is being made to the receive data circuit of these boards located on pages 9-14 to 9-17 of the -200 manual.

- Changed CR301 to separate diodes CR301/CR302 (523-1504-012).
- Changed R308 from 100k to 150k (569-0105-154).
- Added in series with R308, 10k-ohm thermistor RT301 (569-3013-007).

**APPENDIX B CHANGES**

On page A-6 of Appendix A, in Table A-2 the following functions have been added to the Option 1, In, Low Tier box: Data ARQ, Data PTT Revert, PTT.



Part Number 001-9800-203  
4-01hph Printed in U.S.A.