

UNREVISED POWER CONTROL BOARD COMPONENT LAYOUT  
(SOLDER SIDE VIEW)

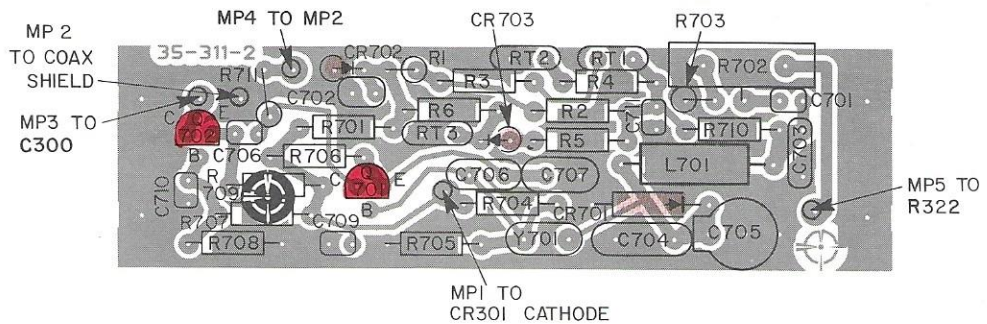

TCXO BOARD COMPONENT LAYOUT  
(SOLDER SIDE VIEW)

NOTE: THE TCXO IS NOT FIELD REPAIRABLE SINCE  
COMPONENT REPLACEMENT REQUIRES FACTORY RECALIBRATION

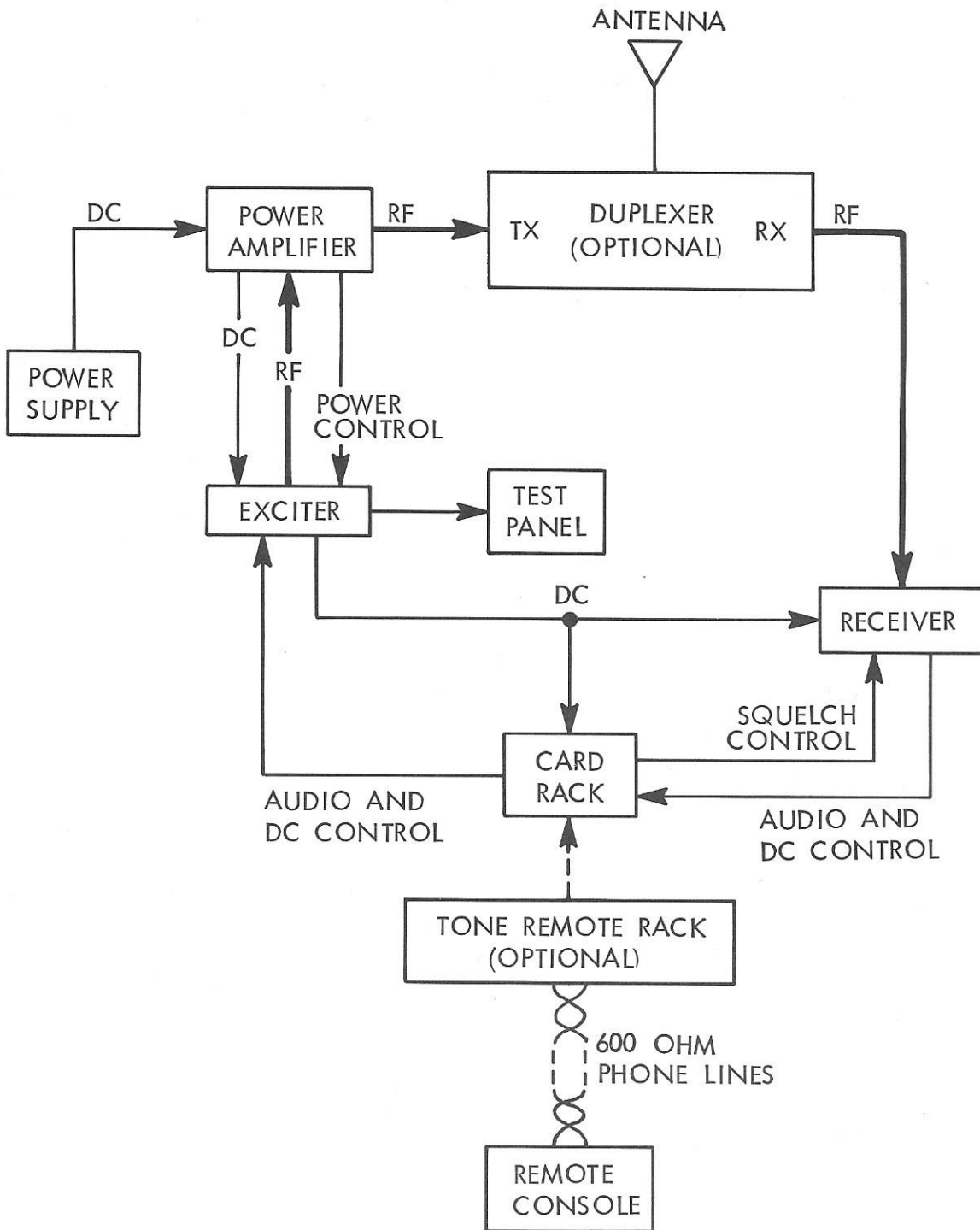

REPEATER BLOCK DIAGRAM



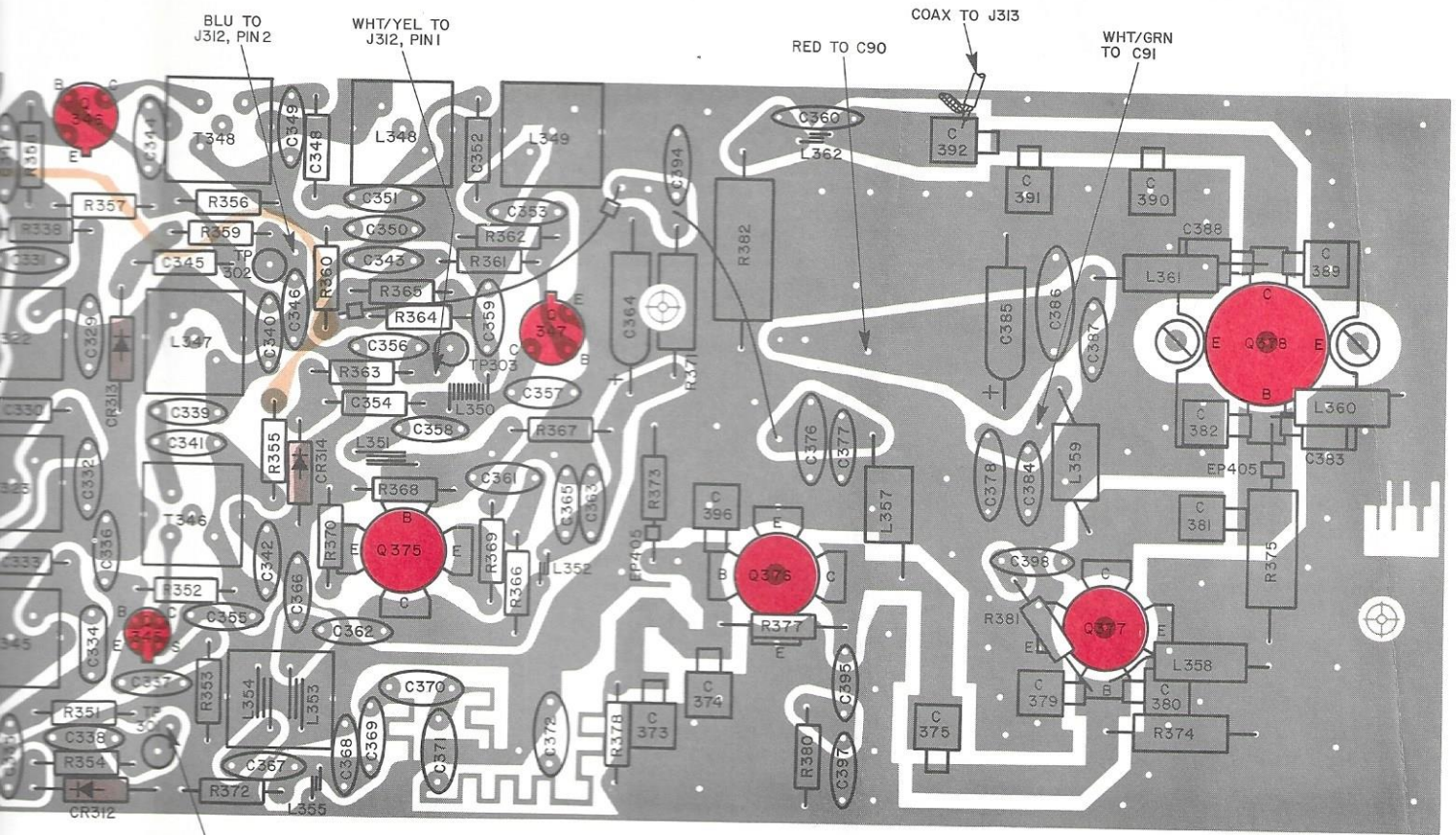

MP3  
P2] WHT TO J312, PIN 8  
CENTER BOARD COMPONENT LAYOUT  
(SOLDER SIDE VIEW)

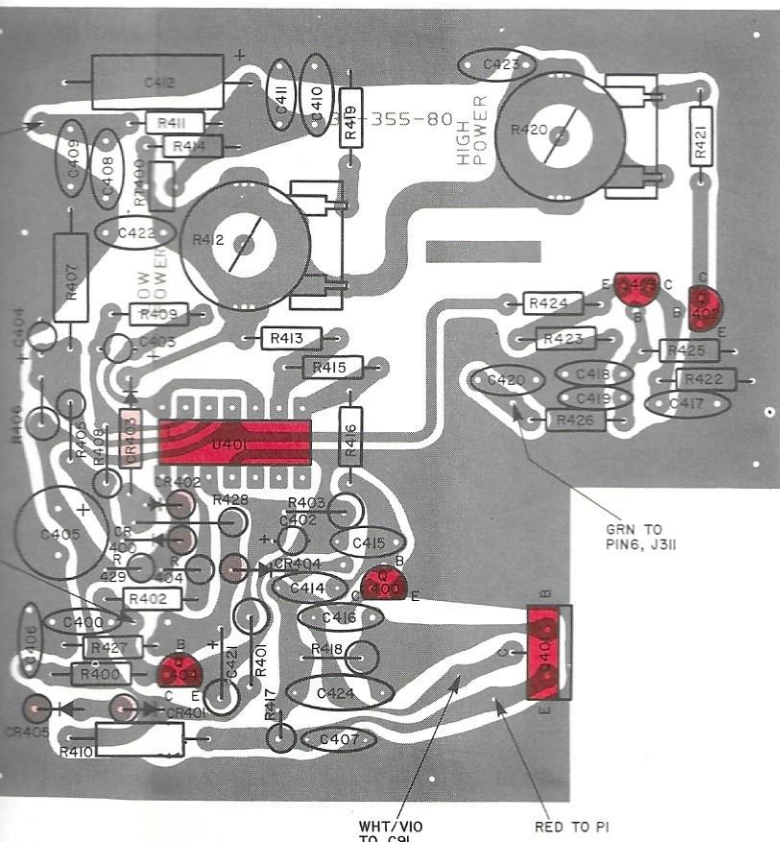

REVISED POWER CONTROL BOARD COMPONENT LAYOUT  
(SOLDER SIDE VIEW)

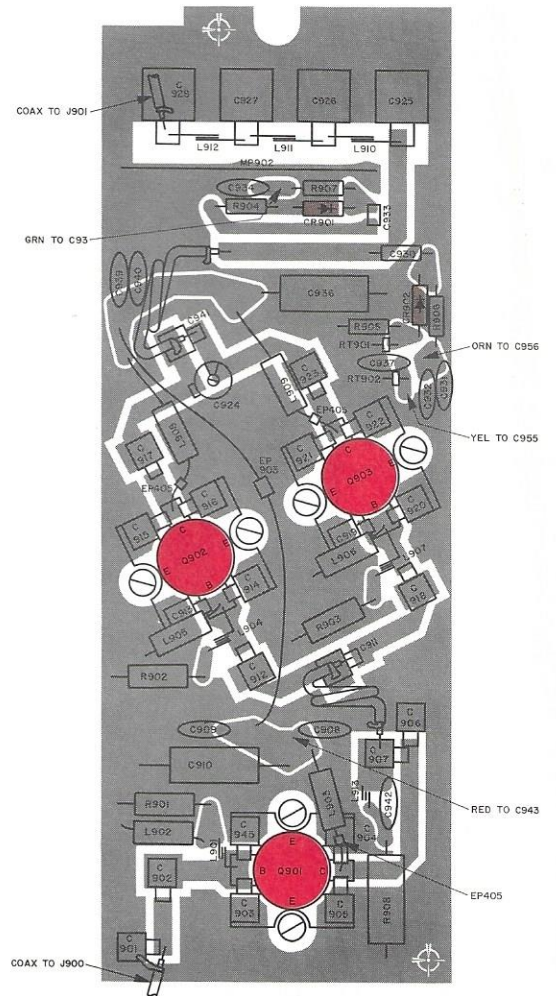

POWER AMPLIFIER BOARD COMPONENT LAYOUT  
(COMPONENT SIDE VIEW)





REPEATER WIRE HARNESS

(USED WITH TONE REMOTE)

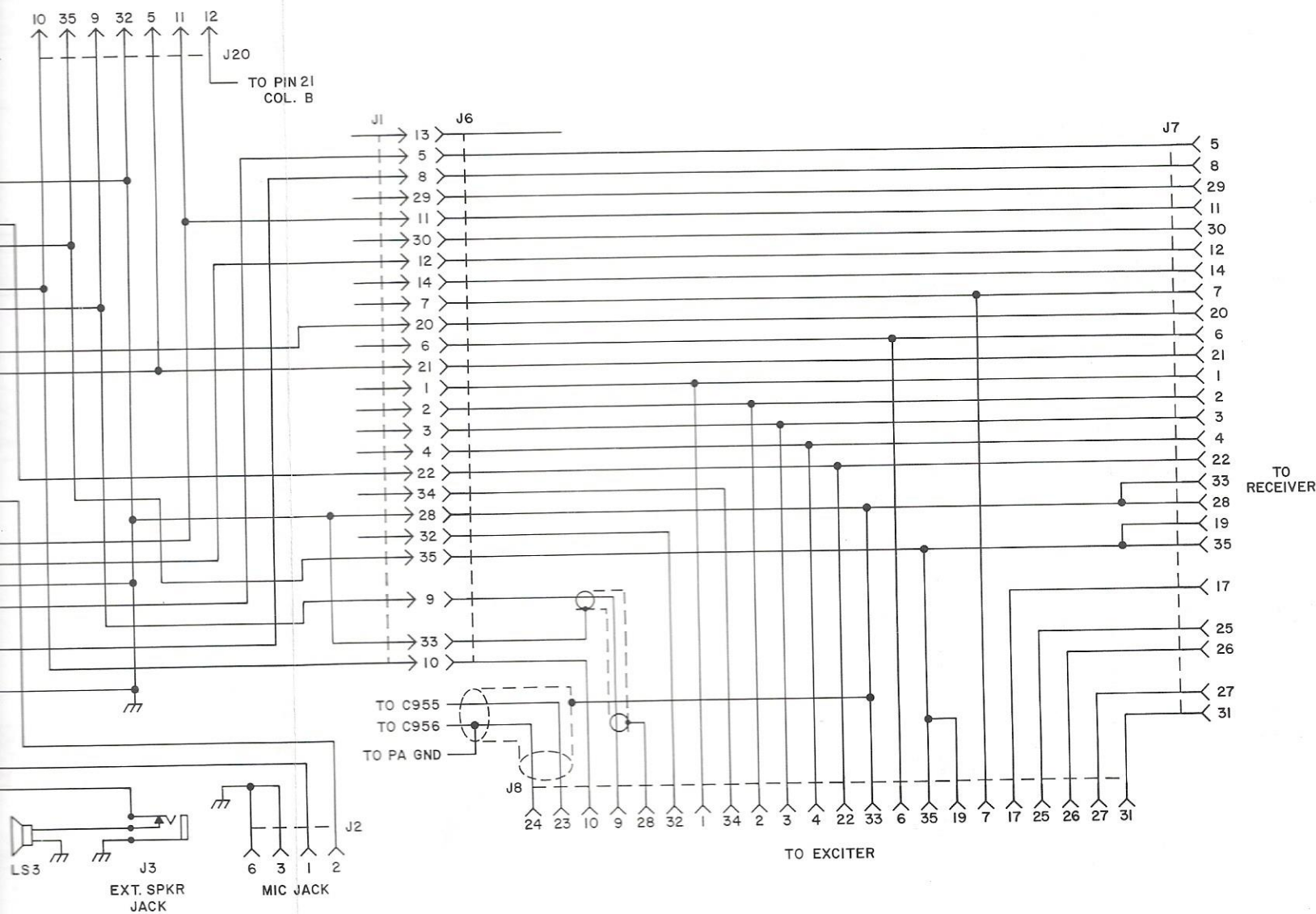

CARD RACK SCHEMATIC DIAGRAM



CARD RACK

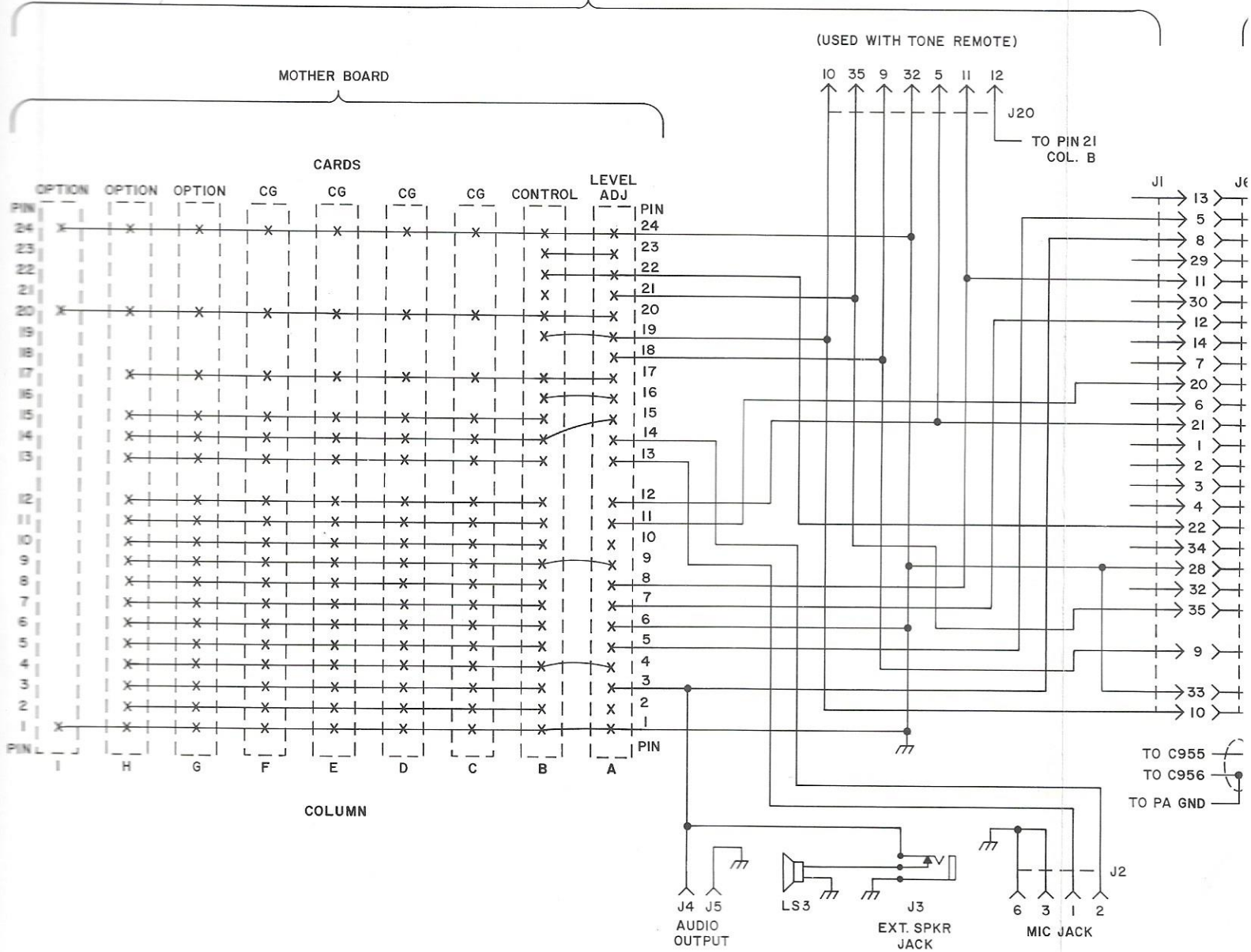

CARD RACK SCHEMATIC DIAGRAM

OLDOUT

**CONTROL CARD**

**CALL GUARD CARD**

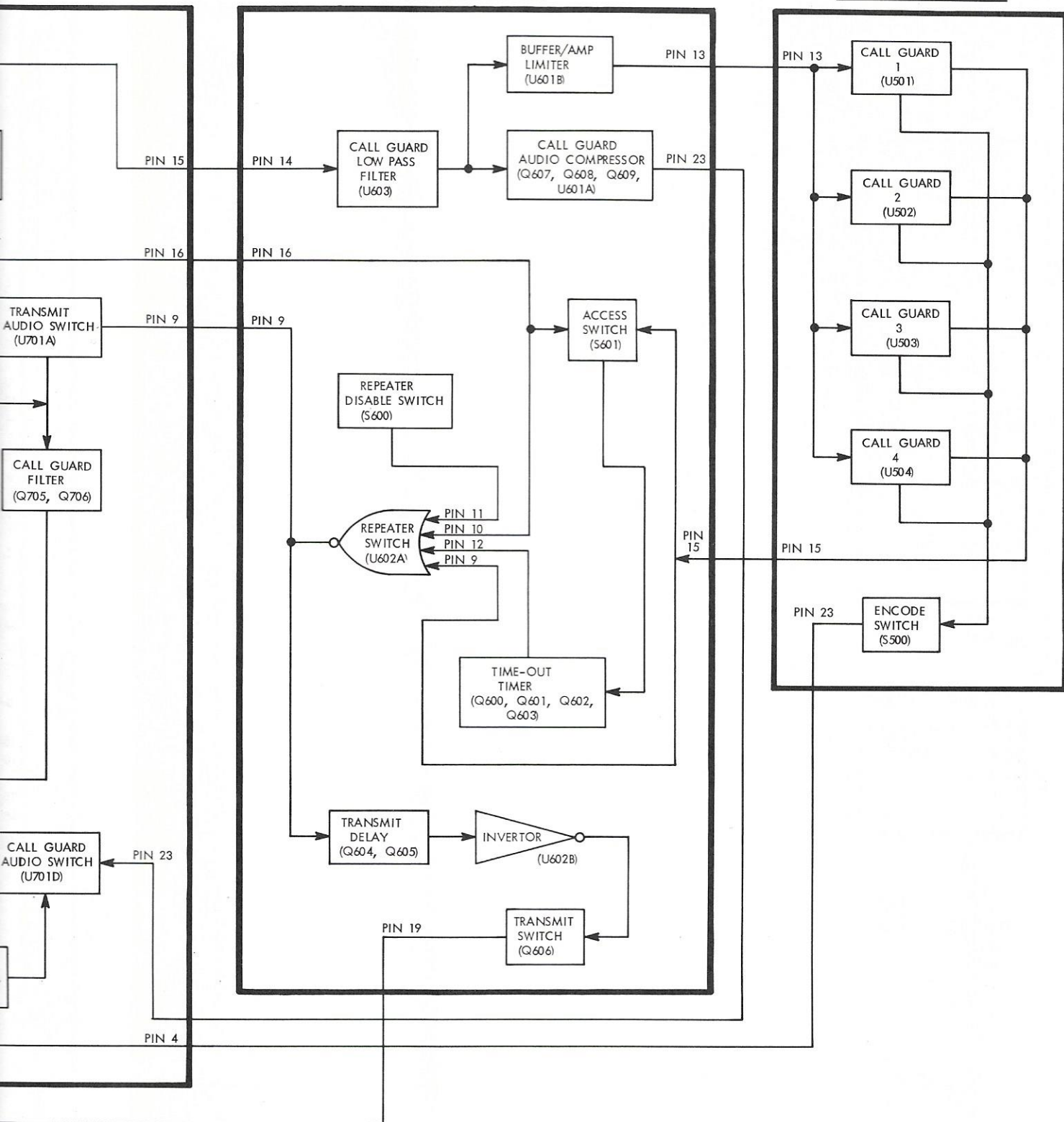

CARD RACK BLOCK DIAGRAM





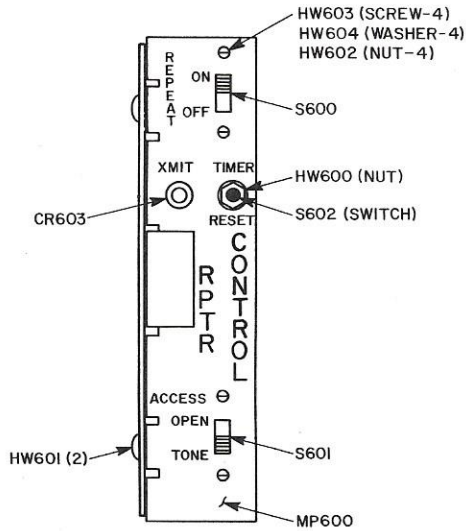

CONTROL CARD FRONT PANEL

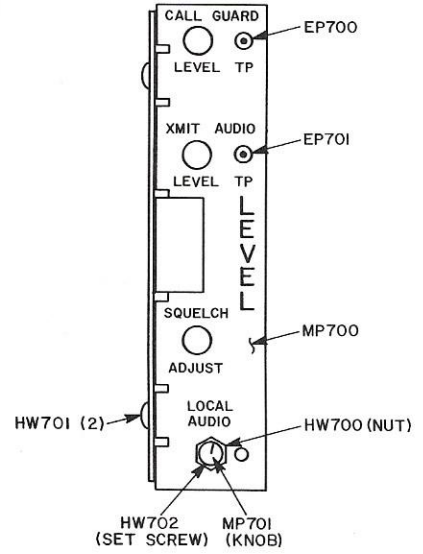

LEVEL ADJUST CARD FRONT PANEL

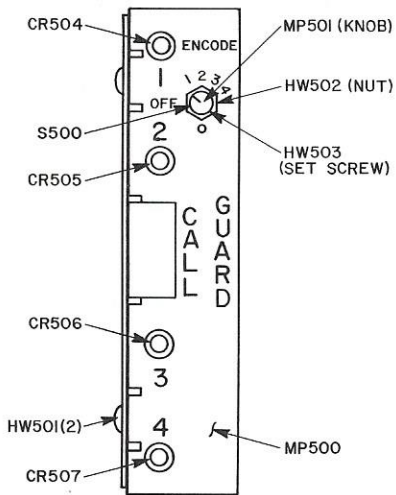

CALL GUARD CARD FRONT PANEL

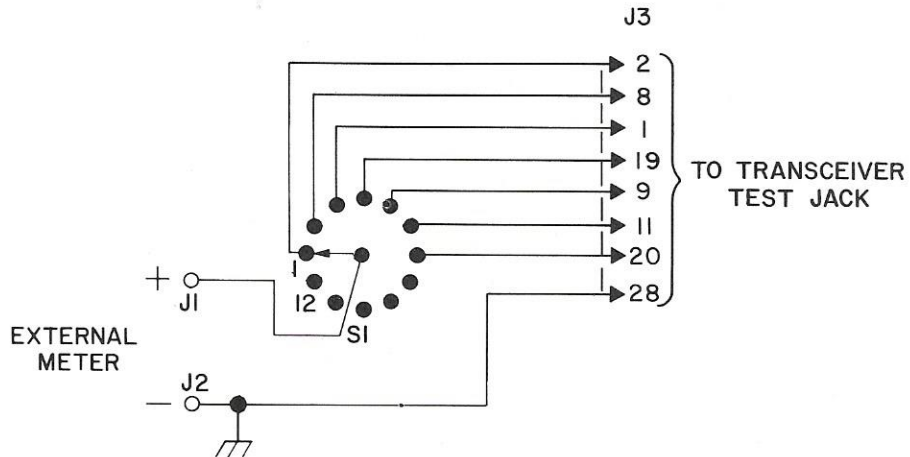

TEST PANEL SCHEMATIC DIAGRAM

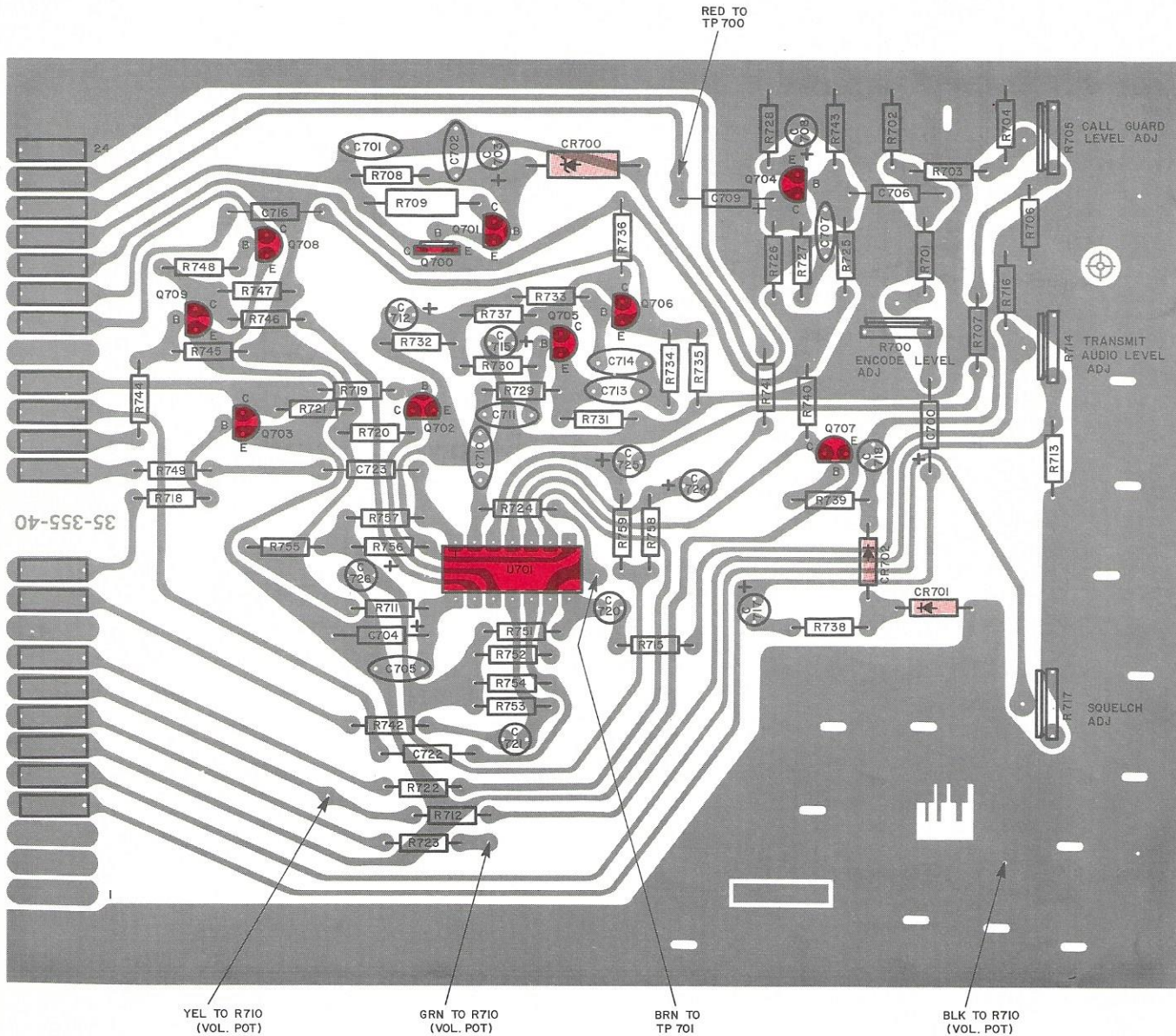

LEVEL ADJUST CARD COMPONENT LAYOUT  
(SOLDER SIDE VIEW)