

IC-125

VHF RADIO TELEPHONE

INSTRUCTION MANUAL

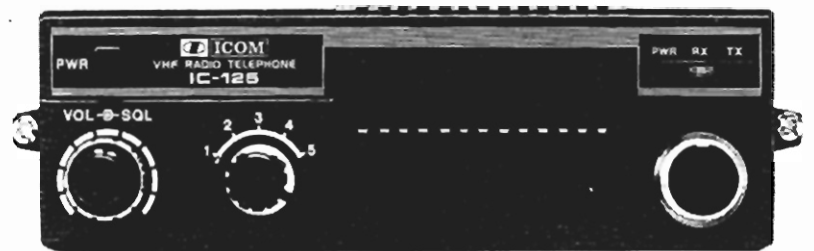

TABLE OF CONTENTS

I. SPECIFICATIONS	1
II. INSTALLATION	2
III. CONTROL FUNCTIONS.....	5
IV. OPERATION	7
V. FREQUENCY PROGRAMMING.....	8

SECTION I SPECIFICATIONS

GENERAL:

Number of Semiconductors	:	Transistors	24
		FET	9
		IC	9
		Diode	30 (not including diodes on the matrix board)
Frequency Coverage	:	One of the following segments	
		150MHz ~ 158MHz	
		155MHz ~ 163MHz	
		161MHz ~ 168MHz	
		166MHz ~ 174MHz	
Operation	:	Simplex/Semi-duplex	
Antenna Impedance	:	50 Ohms unbalanced	
Power Supply Requirements	:	DC 13.8V \pm 15% Negative Ground 6.0A Max.	
Current Drain	:	Transmitting:	Approx. 5.5A
		Receiving:	At Max. Audio. Approx. 1.0A
			Squelched Approx. 0.3A
Operating Temperature	:	-10°C to +50°C	
Dimensions	:	50mm(H) x 150mm(W) x 180mm(D)	
Net Weight	:	1.5Kg	

TRANSMITTER:

Transmitting Frequency	:	5 Channels
Channel Spread	:	2.5MHz maximum
Channel Spacing	:	25KHz spacing (15KHz or 12.5KHz available)
Frequency Stability	:	\pm 0.0005%
Emission Mode	:	16F ₃
Output Power	:	25W
Max. Frequency Deviation	:	5KHz
Modulation System	:	Variable reactance phase modulation
Spurious Emission	:	More than 70dB below carrier
Microphone	:	Impedance: 600 Ohms
		Input level: 10mV typical
		Dynamic or optional Electret condenser microphone

RECEIVER:

Receiving Frequency	:	5 Channels
Channel Spread	:	2.5MHz maximum
Modulation Acceptance	:	16F ₃
Receiving System	:	Double superheterodyne
Intermediate Frequency	:	First IF 21.4MHz
		Second IF 455KHz
Sensitivity	:	Less than 0.3 μ V for 12dB SINAD
Squelch Sensitivity	:	Less than 0.3 μ V
Spurious Response Rejection Ratio	:	More than 80dB
Adjacent Channel Rejection Ratio	:	More than 80dB
Intermodulation Rejection Ratio	:	More than 75dB
Selectivity	:	\pm 6KHz at the -6dB point
		\pm 12.5KHz at the -70dB point
Squelch	:	Dual: Noise compensated squelch
		Continuous Sub-audio Tone squelch option
Audio Output Power	:	More than 2 Watts with less than 10% distortion
Audio Output Impedance	:	4 ~ 8 Ohms

SECTION II INSTALLATION

UNPACKING

Carefully remove your transceiver from the packing carton and examine it for signs of shipping damage. Should any be apparent, notify the delivering carrier or dealer immediately, stating the full extent of the damage. It is recommended you keep the shipping cartons. In the event storage, moving, or reshipment becomes necessary, they come in handy. Accessory hardware, cables, etc., are packed with the transceiver. Make sure you have not overlooked anything.

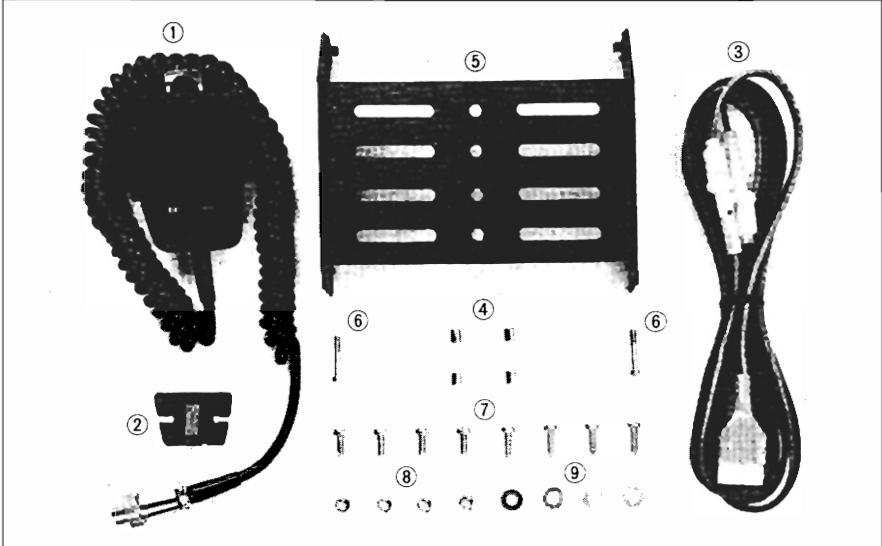

- | | | | |
|--|---|--|---|
| 1. Microphone (dynamic type) | 1 | 6. Mounting bracket retaining screws | 2 |
| 2. Microphone hook | 1 | 7. Mounting screws | 8 |
| 3. Power cord. | 1 | 8. Mounting screw's nuts | 4 |
| 4. Spare fuses. | 2 | 9. Flat washers. | 4 |
| 5. Mounting bracket | 1 | | |

LOCATION

Where you place the transceiver in your automobile is not critical and should be governed by convenience and accessibility. Since the unit is so compact, many mobile possibilities present themselves. In general, the mobile mounting bracket will provide you with some guide as to placement. Any place where it can be mounted with metal screws, bolts, or pop-rivets will work. For fixed station use, a power supply should be designed to produce 6 amps for the transceiver.

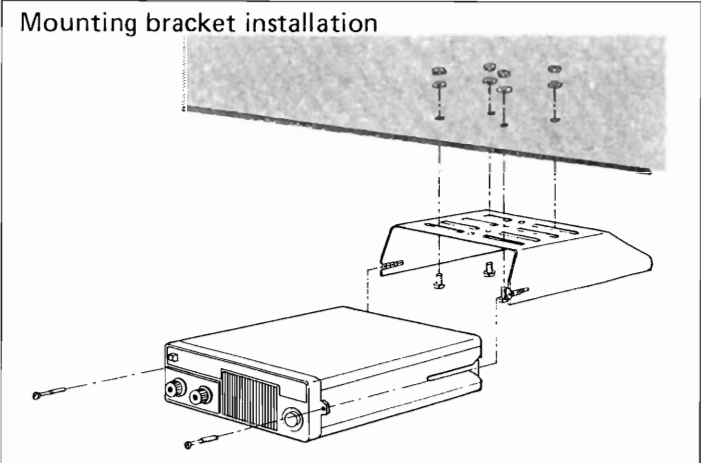

POWER REQUIREMENTS

The transceiver is supplied ready to operate from any regulated 13.8V DC, 6 ampere negative ground source. An automobile 12 volt, negative ground, system is usually more than adequate. Some note must be taken, however, of the condition of the vehicle's electrical system. Items such as low battery, worn generator/alternator, poor voltage regulator, etc., will impair operation of your transceiver as well as the vehicle. High noise generation or low voltage delivery can be traced to these deficiencies. If an AC power supply is used with your transceiver, make certain it is adequately regulated for both voltage and current. Low voltage while under load will not produce satisfactory results from your transceiver. Receiver gain and transmitter output will be greatly impaired. Caution against catastrophic failure of the power supply should be observed.

CAUTION: Excessive Voltage (above 15V DC) will cause damage to your transceiver. Be sure to check source voltage before plugging in the power cord.

Included with your transceiver is a DC power cable with plug attached. The Red Wire is positive (+), the Black, negative (-). If your mobile installation permits, it is best to connect these directly to the battery terminals. This arrangement eliminates random noise and transient spikes sometimes found springing from automotive accessory wiring. If such an arrangement is not possible, then any convenient B+ lead in the interior of the vehicle and the negative frame can be utilized. Remember, the unit operates on a negative ground system only; it cannot be used in a positive ground automobile. After making your connections, simply insert the plug into your transceiver.

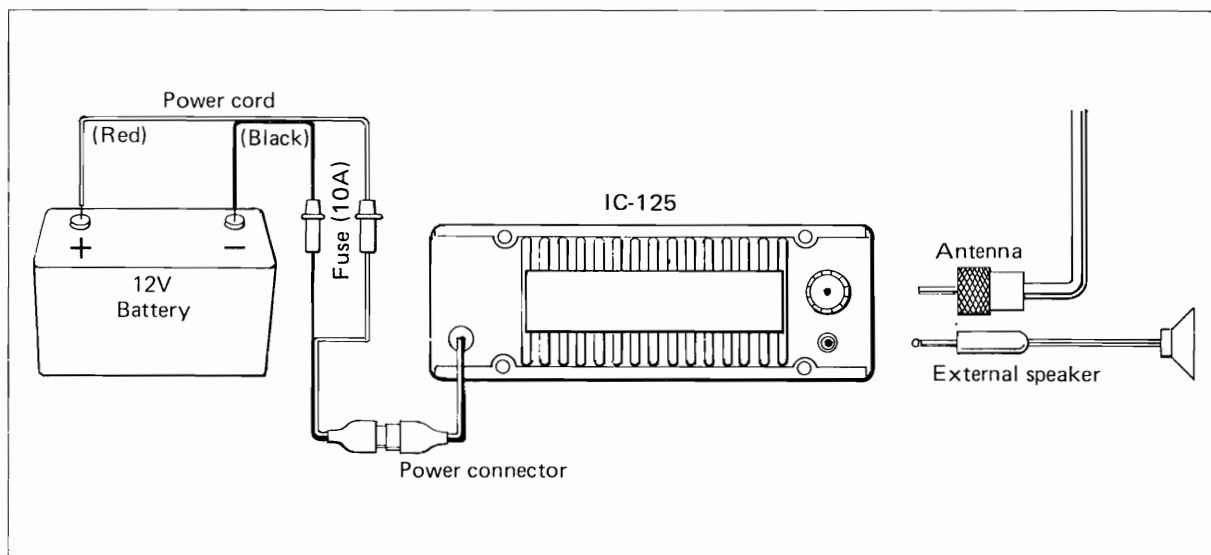

ANTENNA

The most important single item that will influence the performance of any communication system is the antenna. For that reason, a good, high-quality, gain antenna of 50 ohms impedance is recommended, fixed or mobile. In VHF as well as the low bands, every watt of ERP makes some difference. Therefore, 25 watts average output plus 3dB of gain antenna equals 50 watts ERP, presuming low VSWR of course. The few extra dollars invested in a gain type antenna is well worth it. When adjusting your antenna, whether mobile or fixed, by all means follow the manufacturer's instructions. There are some pitfalls to be aware of. For example, do not attempt to adjust an antenna for lowest VSWR when using a diode VSWR meter not engineered for VHF applications. Such readings will invariably have an error of 40% or more. Instead, use an in line watt meter similar to the Bird Model 43 or Sierra Model 164B with a cartridge for the operating frequency range. Furthermore, when adjusting a mobile antenna, do so with the motor running preferably above normal idling speed. This will insure proper voltage level to the transceiver.

The RF coaxial connector on the rear chassis mates with a standard PL-259 connector. Some models may have metric threads. In any event, the RF connector will mate with almost any PL-259 connector if care is taken to seat it properly.

MICROPHONE

A high quality dynamic microphone is supplied with your transceiver. Merely plug it into the proper receptacle on the front panel. Should you wish to use a different microphone, make certain it has a proper hook up. Particular care should be exercised in wiring also, as the internal electric switching system is dependent upon it. See the schematic for the proper hook up.

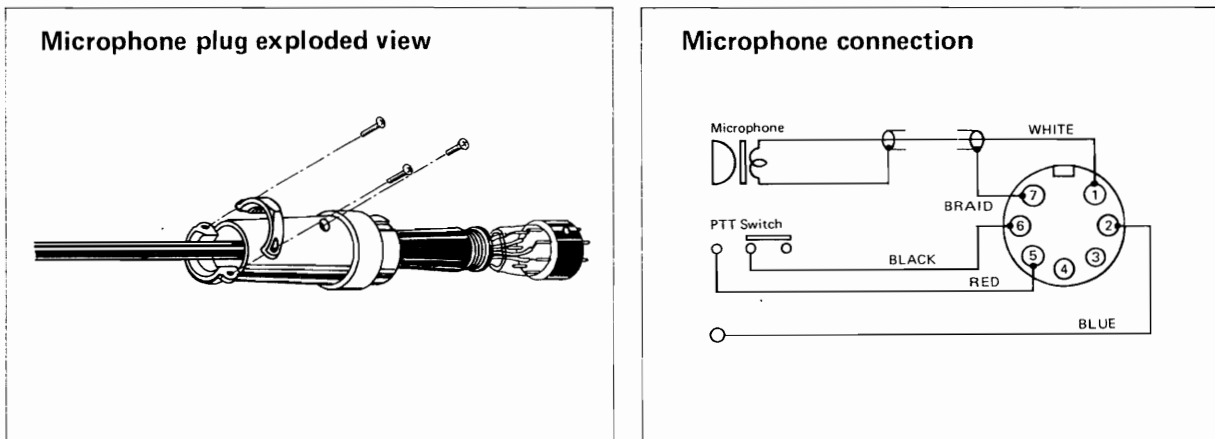

EXTERNAL SPEAKER

An external speaker jack and plug is supplied with your unit in the event another speaker is desirable. The external speaker impedance should be 4 ~ 8 ohms, and when used, will disable the internal speaker. An 8 ohm headset can be utilized as well.

SECTION III CONTROL FUNCTIONS

FRONT PANEL

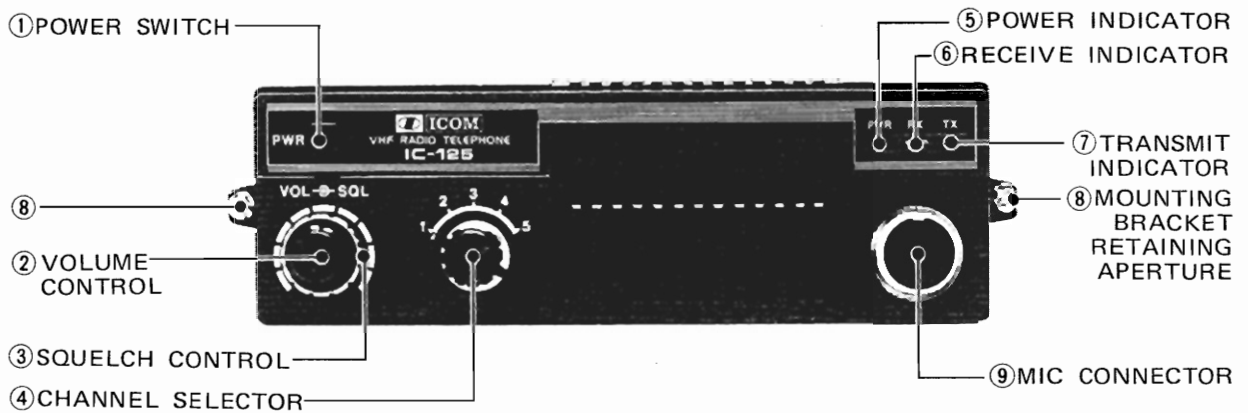

1. POWER SWITCH

A push lock type ON/OFF switch controls the supplied power to the set. Push the switch IN (lock position) to apply power to the set.

2. VOLUME CONTROL

Controls the audio output level in the receive mode. Clockwise rotation increases audio output.

3. SQUELCH CONTROL

Sets the squelch threshold level. To turn OFF the squelch function, rotate this control completely counterclockwise. To set the threshold level higher, turn the control clockwise.

4. CHANNEL SELECTOR

This switch selects the operating frequency.

5. POWER ON INDICATOR

When the set is turned ON, this indicator is lit.

6. RECEIVE INDICATOR

Illuminates when the squelch is opened in the receive mode.

7. TRANSMIT INDICATOR

When your set is in the transmit mode this indicator is lit.

8. MOUNTING BRACKET RETAINING APERTURE

9. MIC CONNECTOR

Connect the supplied microphone or optional microphone to this jack. The IC-SM3 stand-type Electret microphone or IC-HS1 hand set can also be used. If you wish to use a microphone other than one of these, refer to the drawing on page 4.

REAR PANEL

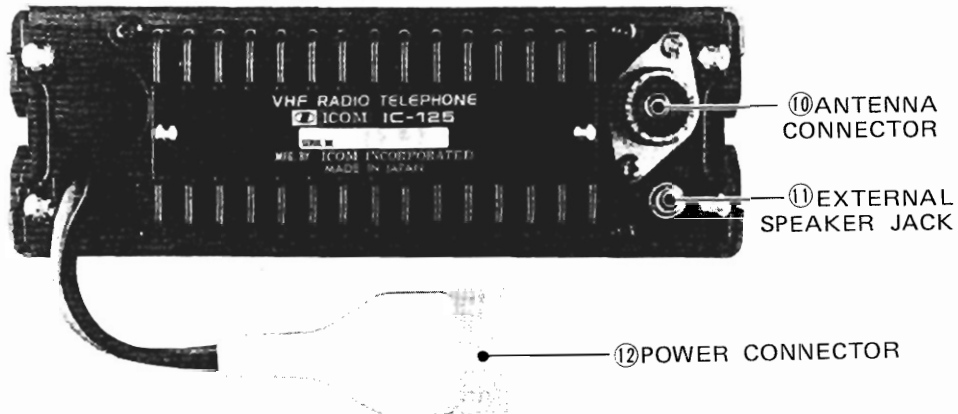

10. ANTENNA CONNECTOR

This is used to connect the antenna to the set. Its impedance is 50 ohms and connects with a PL-259 connector.

11. EXTERNAL SPEAKER JACK

When an external speaker is used, connect it to this jack. Use a speaker with an impedance of 4 ~ 8 ohms. When the external speaker is connected, the built-in speaker does not function.

12. POWER CONNECTOR

Connect the supplied power cord to this connector.

SECTION IV OPERATION

INITIAL PREPARATIONS:

Make sure the power switch is in the OFF position, then connect the power supply cord to the power connector. The red lead should be connected to the positive side of the power source and the black lead to the negative side. In the event that these leads are improperly connected, the transceiver will not function. Reversing polarity will blow out the fuse in the power supply cord due to actuation of the protective circuit.

Connect the microphone to the mic connector.

Connect the antenna to the antenna connector. Make sure the coaxial line is of the correct impedance (50 ohms) and is neither shorted nor opened.

OPERATION:

Turn the volume and squelch controls to the fully counterclockwise position.

Switch the channel selector to the desired channel.

Lift the microphone from the microphone hook. (With the installed Continuous Tone Coded Squelch System, CTCSS, only.)

Push and lock the power switch, and the power ON indicator and receive indicator will illuminate.

RECEPTION:

Adjust the volume control to a comfortable listening level of noise, if no signal is present.

Carefully adjust the squelch control clockwise until the noise just disappears, and the receive indicator goes out. This is the proper squelch threshold setting and must be done when no signal is present. Your transceiver will now remain silent until an in-coming signal is received which opens the squelch and lights the receive indicator. If the squelch is unstable due to the reception of weak or mobile stations, adjust the squelch control further until the proper threshold is obtained.

With the CTCSS installed, hang the microphone on the microphone hook, then you can hear a signal only from a station that has the same frequency CTCSS installed.

TRANSMITTING:

Push the PTT (push to talk) button on the microphone and the transceiver will transmit. At the same time the transmit indicator will be illuminated red. Hold the microphone about three inches from your mouth and speak in a normal voice. The microphone is of the dynamic type and provides good pickup for all voice levels.

To receive again, just release the PTT button. This will also switch off the transmit light.

With the CTCSS installed, when the microphone is removed from the microphone hook, you can hear the other stations that may be using the same channel but do not have a CTCSS frequency the same as the station you wish to communicate with.

Avoid interference with those other stations, and talk only when they have concluded their transmissions using the same procedure described above.

When communication has ended, hang the microphone on the microphone hook as before.

SECTION V FREQUENCY PROGRAMMING

The transceiver has 5 channels, both transmit and receive. The channel selector switch selects one transmit and one receive channel in each of its 5 positions.

The amount of frequency spread between any two receiving or any two transmitting frequencies should not exceed 2.5MHz. Since the receiver and transmitter are independent of each other, you may have any practical amount of frequency separation you wish here. Only two or more widely spaced frequencies for the receiver alone or for the transmitter alone need be considered under the 2.5MHz limitation.

Desired operating frequency can be programmed by mounting certain diode(s) on the MATRIX board.

1. Calculate the "N" number of the desired operating frequency, using the programming formula for each version shown below. ("N" is divided number of the programmable divider in the Phase Locked Loop, and is determined by the BCD code.)

For F1 (150MHz ~ 158MHz) version:

$$N = \frac{\text{Desired Frequency (MHz)} - 21.4 - 126.875}{0.005^*}$$

For F2 (155MHz ~ 163MHz) version:

$$N = \frac{\text{Desired Frequency (MHz)} - 21.4 - 132.1}{0.005^*}$$

For F3 (161MHz ~ 168MHz) version:

$$N = \frac{\text{Desired Frequency (MHz)} - 21.4 - 137.1}{0.005^*}$$

For F4 (166MHz ~ 174MHz) version:

$$N = \frac{\text{Desired Frequency (MHz)} - 21.4 - 142.65}{0.005^*}$$

* If your transceiver is a 12.5KHz channel spacing version, use "0.00625" instead of "0.005".

2. Convert each digit of the "N" number to BCD, using the conversion table shown below.

N	BCD	N	BCD
1	0001	6	0110
2	0010	7	0111
3	0011	8	1000
4	0100	9	1001
5	0101	0	0000

Example: If N = 1259, BCD = 1 0010 0101 1001

3. Mount diodes corresponding to the chosen channel, using the BCD number, when "1" = diode mounted, and "0" = diode not mounted. The first digit of the BCD corresponds to the first row (N = 1), where is next to the 10-pin connector on the MATRIX board, the second digit of the BCD corresponds to the second row (N = 2), the third digit, to the third row (N = 4), and so on.

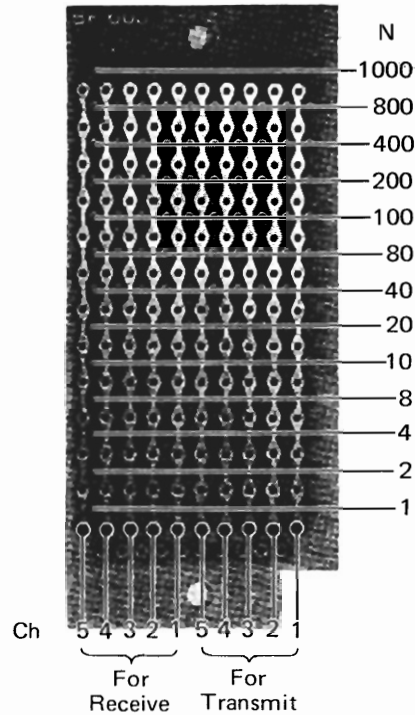

4. Complete programming for additional desired channels in the same manner. The receive and transmit frequencies must be programmed individually, even if the both frequencies are the same.



ICOM INCORPORATED
1-6-19, KAMI KURATSUKURI, HIRANO-KU,
OSAKA JAPAN