

500-Watt, 900-MHz Power Amplifier

USER MANUAL

PN 9110.00162 (old part number =916-8600-004)

REV D

RELEASED

Specifications subject to change without notice

Copyright © 1996 Glenayre

All rights reserved. No part of this work may be reproduced or copied in any form or by any means—graphic, electronic, or mechanical, including photocopying, recording, taping, or information-retrieval system—without written permission of Glenayre.

Document Change Record

Revision: B
Date: 02/01/96
Changes: new format

Issue: Rev C
Date: 05/24/96
Changes: new RF output specifications

Issue: Rev. D
Date: 05/30/96
Changes: new RF output specifications

Table of Contents

1	GENERAL	1-1
1.1	Manual Scope	1-1
1.2	Applicable Documents	1-1
1.3	Manual Sections	1-1
2	SPECIFICATIONS	2-1
3	DESCRIPTION	3-1
3.1	Introduction	3-1
3.2	Physical Description	3-1
3.2.1	Mounting Provisions	3-1
3.2.2	PA Front	3-1
3.2.2.1	Driver Board	3-2
3.2.2.2	Combiner Board	3-2
3.2.2.3	Metering Board	3-2
3.2.3	PA Rear	3-2
3.2.3.1	Isolator	3-2
3.2.3.2	PA Boards	3-5
3.2.3.3	Equipment Connectors	3-5
3.3	Functional Description	3-5
3.3.1	RF Amplifier	3-5
3.3.2	Isolator	3-5
3.3.3	Metering	3-5
4	INSTALLATION AND SETUP	4-1
4.1	Precautions and Hazards	4-1
4.2	Test Equipment and Tools Required	4-1
4.3	Installation	4-1
4.3.1	Rack Positioning	4-1
4.3.2	Rack Grounding	4-2
4.3.3	Equipment Inspection	4-2
4.3.4	Equipment Cabling	4-2
4.3.5	Equipment Mounting	4-2
4.3.6	Ultimate Disposition	4-2
4.4	Setup	4-3
5	OPERATION	5-1
5.1	Controls and Indicators	5-1
5.2	Operation	5-1

- 5.2.1 Turn PA On and Off 5-1
- 5.2.2 Turn Fan On and Off 5-1
- 5.2.3 Key and Unkey PA 5-1
- 6 THEORY OF OPERATION 6-1**
- 6.1 Power Distribution 6-1
 - 6.1.1 Primary Power 6-1
 - 6.1.1.1 Metering Board +25V Signal Flow. 6-1
 - 6.1.1.2 Power Amplifiers +25V Signal Flow. 6-1
 - 6.1.2 Secondary Power 6-2
 - 6.1.2.1 Metering Board +13.5V Signal Flow. 6-2
 - 6.1.2.2 Preamplifier Module +13.5V Signal Flow 6-2
 - 6.1.3 Fan Power. 6-2
- 6.2 RF Distribution 6-3
 - 6.2.1 Driver Board RF Flow 6-3
 - 6.2.2 PA Board RF Flow 6-4
 - 6.2.3 Combiner Board RF Flow 6-4
 - 6.2.4 Isolator RF Flow 6-4
- 6.3 Control Distribution 6-5
 - 6.3.1 AGC Signal Flow. 6-5
 - 6.3.2 Multiplexer Control Signal Flow 6-5
- 6.4 Status Distribution 6-5
 - 6.4.1 Mux Analog Status Signal Flow 6-6
 - 6.4.2 PA Fault Signal Flow. 6-6
- 7 MAINTENANCE 7-1**
- 8 CHECKOUT AND TROUBLESHOOTING 8-1**
- 9 REMOVAL AND REINSTALLATION 9-1**
- 9.1 PA Chassis Removal and Reinstallation 9-1
- 9.2 PA RF Module Removal and Reinstallation 9-1
- 9.3 Metering Board Removal and Reinstallation 9-1

List of Figures

Figure 3-1	500-Watt, 900-MHz Power Amplifier Front View	3-3
Figure 3-2	500-Watt, 900-MHz Power Amplifier Rear View	3-4
Figure 3-3	Simplified Block Diagram	3-6
Figure 5-1	Front-Panel View with Cover Removed	5-2
Figure 6-1	500-Watt PA Interconnection Diagram.	6-8
Figure 6-2	500-Watt PA Functional Diagram	6-9
Figure 6-3	500-Watt PA Detailed Functional Diagram	6-10
Figure 6-4	Metering Board Functional Diagram	6-12
Figure 9-1	PA Removal and Reinstallation.	9-2
Figure 9-2	PA RF Module Removal and Reinstallation	9-4
Figure 9-3	Metering Board Removal and Reinstallation	9-6

List of Tables

Table 1-1	Applicable Documents	1-1
Table 1-2	Manual Sections	1-2
Table 2-1	Power Amplifier Specifications.	2-1
Table 3-1	PA Circuit Boards.	3-1
Table 4-1	Test Equipment Required.	4-1
Table 6-1	Multiplexer Analog Status Inputs.	6-7

1 GENERAL

1.1 Manual Scope

This manual provides information for the 500-watt, 900-MHz Gold Line power amplifier, part number 265-0082-013. Also included is information for the optional triple isolator, part number 7914.00010.

1.2 Applicable Documents

This manual is incomplete without additional Gold Line manuals. Refer to *Table 1-1* for a listing and function of these manuals.

Table 1-1 Applicable Documents

document	part number	function
GL-T8500/T8600 system manual	9110.00163	describes fully racked-up Gold Line transmitter
VDT manual	9110.00164	describes PA control software installed in exciter
exciter manual	9110.00172	describes exciter/PA control equipment in transmitter
500-watt PA	9110.00162	this manual
power supply manual	9110.00159	describes 50A/90A power supply equipment in transmitter

1.3 Manual Sections

Table 1-2 lists the sections of this manual with a summary of their contents.

Table 1-2 Manual Sections

section	contents
1. general	introduction and purpose of manual
2. specifications	significant measurements of power amplifier
3. description	introduction and principal characteristics of power amplifier
4. installation and setup	initial installation and activation of power amplifier
5. operation	operation of power amplifier
6. theory of operation	detailed functional description of circuitry within power amplifier
7. maintenance	procedures to be performed on specific intervals to maintain optimum performance of power amplifier
8. checkout and troubleshooting	verification of proper operation, correction to proper operation of power amplifier
9. removal and reinstallation	replacement procedures for power amplifier and selected subassemblies

2 SPECIFICATIONS

Table 2-1 lists the significant equipment-level specifications for the Gold Line power amplifier.

Table 2-1 Power Amplifier Specifications

measurement	specification
height	8.75 in (22.23 cm)
width	19 in (48.3 cm)
depth	8 in (20.3 cm)
weight	26 lb (12 kg)
RF output power	200 - 600 watts
RF bandwidth	900 - 960 MHz
RF input power	200 - 400 mW
RF impedance	50 ohms
operating voltages	25 vdc, 25 Vdc, 13.5 Vdc
PA 25 Vdc current	72 mA - 33 A
fan 25 Vdc current	750 mA
13.5 Vdc current	3.3 A
ambient temperature	-30° - +70° C
humidity	0 - 95% noncondensing
altitude	to 10,000 ft (3050 m)

3 DESCRIPTION

3.1 Introduction

Figure 3-1, 500-Watt, 900-MHz Power Amplifier Front View, and Figure 3-2, 500-Watt, 900-MHz Power Amplifier Rear View, show the Gold Line power amplifier (PA). This is a 500-watt PA intended for use in a GL-T8600 paging transmitter with an RF of 900 MHz nominal. This PA is characterized by integrated monitoring devices that supply critical status information to a Gold Line exciter/PA control (exciter). This exciter contains diagnostic software that can detect and report a faulty PA circuit board.

3.2 Physical Description

3.2.1 Mounting Provisions

The PA is mounted to the front of most standard 19-inch equipment racks by means of eight screws. The front panel of the PA may be removed while the PA is mounted in the rack. Two quarter-turn fasteners secure the front panel to the PA. Most PA circuit boards may be replaced while the PA is mounted in the rack.

3.2.2 PA Front

Figure 5-1, Front-Panel View with Cover Removed, shows the front view of the PA with the front panel removed. This exposes the RF and shielded compartments, which contain the PA circuit boards. *Table 3-1* lists the PA circuit boards.

Table 3-1 PA Circuit Boards

nomenclature	part number	location
driver board	263-0082-008	RF compartment
PA1 board	263-0082-007	RF compartment
PA2 board	263-0082-007	RF compartment
PA3 board	263-0082-007	RF compartment
PA4 board	263-0082-007	RF compartment
combiner board	263-0082-009	RF compartment
metering board	263-0082-003	shielded compartment

3.2.2.1 Driver Board

The driver board contains the preamp module, the intermediate PA (IPA), and the PA drivers (driver-1, driver-2, driver-3, and driver-4). These devices, in addition to one resistor, are mounted directly on the PA heat sink. The driver board contains three connectors: two on the front (J1 and J2) and one on the back (J3). Two RG316-type cables (not shown) are attached to the front of the board.

heat sink. Connectors J1 and J3 and an RG142-type cable (not shown) are attached to the front of each board.

3.2.2.2 Combiner Board

The combiner board combines the outputs of the PA boards. The combiner board contains a resistor, mounted directly on the PA heat sink. Connectors J1, J2, J3, and J4 are on the front of the board. An RG393-type cable is attached to the back of the board. This cable terminates with a type-N connector and extends through the rear of the PA.

3.2.2.3 Metering Board

The metering board contains the monitoring circuits for the PA. A bank of nine automotive spade-type fuses protect the PA. A transistor is mounted directly on the PA heat sink. The metering board contains connectors J1, J2, J3, J4, J5, and P1 on the front. The board contains one LED (DC POWER).

3.2.3 PA Rear

Figure 3-2 shows the back view of the PA. The PA back panel conceals the fan compartment. The isolator and fan are mounted on the back panel. The PA equipment connectors terminate on cables that are routed through grommets holes in the back panel.

3.2.3.1 Isolator

The standard isolator (shown) improves the intermodulation performance of the PA by 25 dB. This isolator is mounted on its own heat sink, which extends into the fan compartment. The optional triple isolator (not shown) improves the intermodulation performance of the PA by 75 dB, and is mounted on the PA. Both isolators contains three connectors: two type-N and one BNC.

v0072.hgl

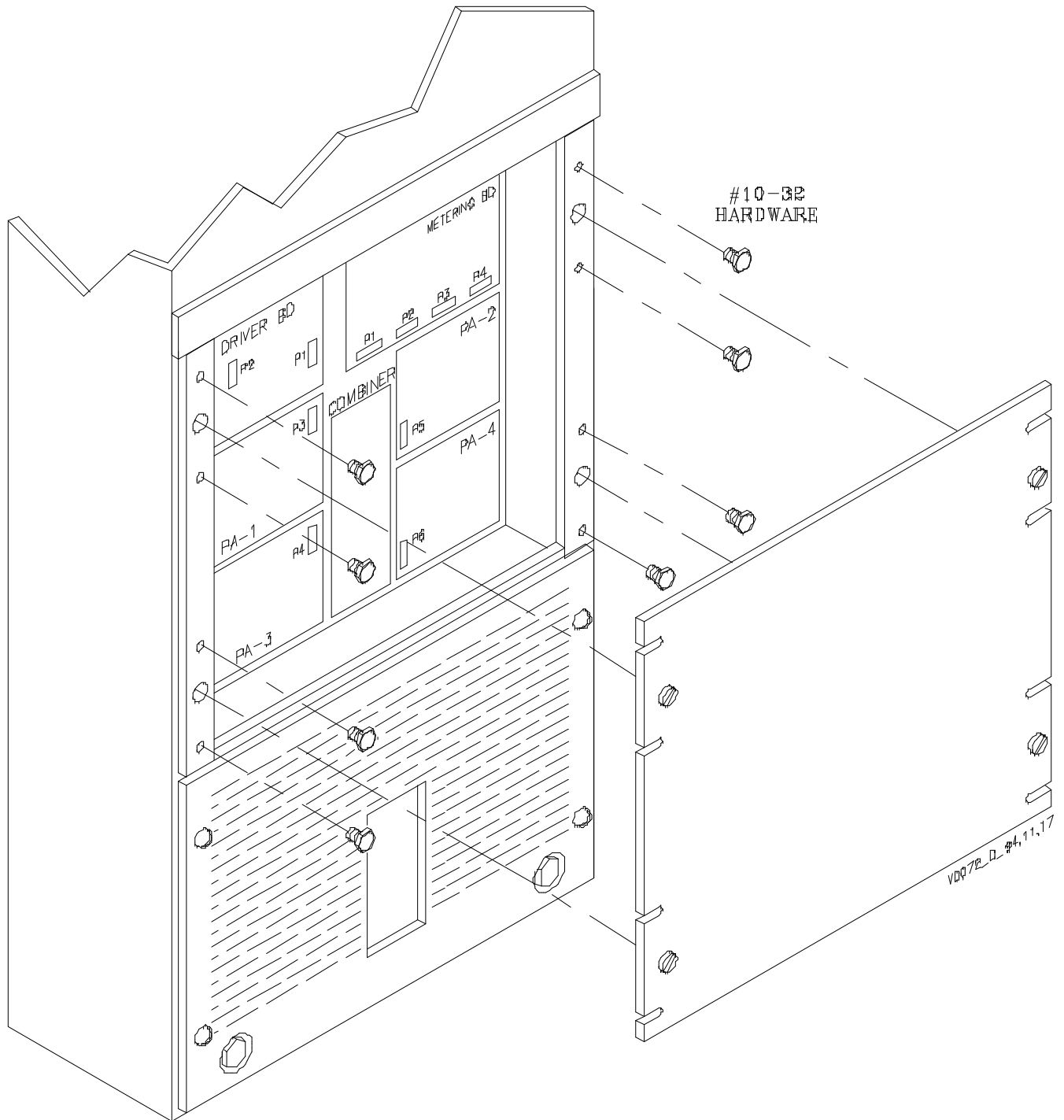

Figure 3-1 500-Watt, 900-MHz Power Amplifier
Front View

v0082.hgl

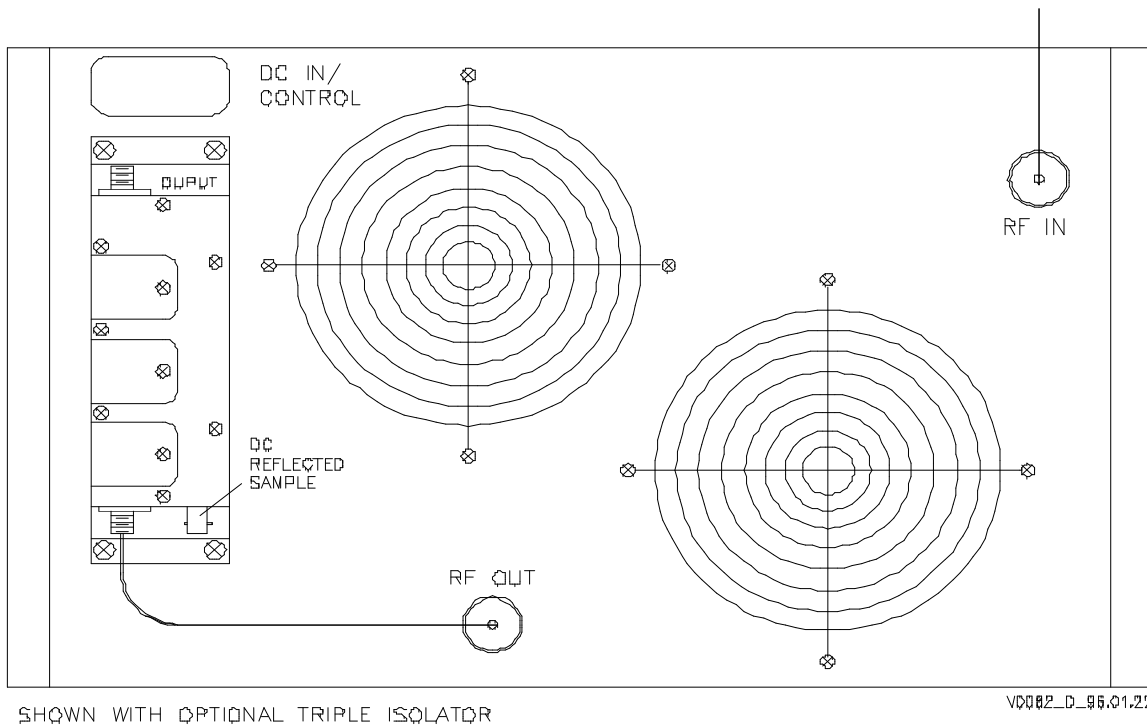

Figure 3-2 500-Watt, 900-MHz Power Amplifier
Rear View

3.2.3.2 PA Boards

Four PA boards, PA1, PA2, PA3, and PA4, contain the power amplifiers. The PA boards are identical but are mounted with different orientations. Each PA board contains an A and a B pair of power amplifiers. These amplifiers and six resistors are mounted directly on the PAFan

Two fans provide cooling for the PA and standard isolator. The fan is located within the fan compartment and is covered by a finger guard. The fan runs continuously whenever power is applied by the power supply equipment.

3.2.3.3 Equipment Connectors

There are five equipment connectors in addition to those on the isolator. Two 1/4-inch ring lugs are designated as plus (red) and minus (black). A 9-pin plug-and-socket connector is designated as P2. A DB15-type connector is designated as PA CONTROL. A BNC connector is designated as P3.

3.3 Functional Description

Figure 3.3.1 shows a simplified, functional diagram of the PA. The driver, combiner, and PA boards constitute the RF amplifier circuitry of the PA. Monitoring and controlling this RF amplifier is the metering board. *Figure 3-1* shows the RF amplifier, isolator, and metering circuitry within the PA.

3.3.1 RF Amplifier

The RF amplifier receives its RF input through the BNC connector P3. A detector circuit in the RF amplifier monitors this RF input. The RF input is amplified by means of four amplifier stages. Each amplifier stage receives its dc input power through the metering circuit. Power detectors at critical locations throughout the RF amplifier provide sample voltages to the metering circuit. The amplified output of the RF amplifier is applied to the input type-N connector on the isolator.

3.3.2 Isolator

The isolator prevents intermodulation of the RF signal that may occur from nearby transmissions. The RF signal is routed through input and output type N connectors. A detector circuit in the isolator monitors the reflected power (VSWR) present at the output type-N connector. A sample voltage representing the VSWR level is output through the BNC connector. The optional triple isolator functions identically to the standard isolator except with a higher level of intermodulation prevention.

3.3.3 Metering

The metering board performs control and status reporting for the PA. The metering board accepts a 25-Vdc power input through the 1/4-inch lugs and a 13.5-Vdc power input through connector P2. These voltages are regulated and distributed.

v0045.tbl

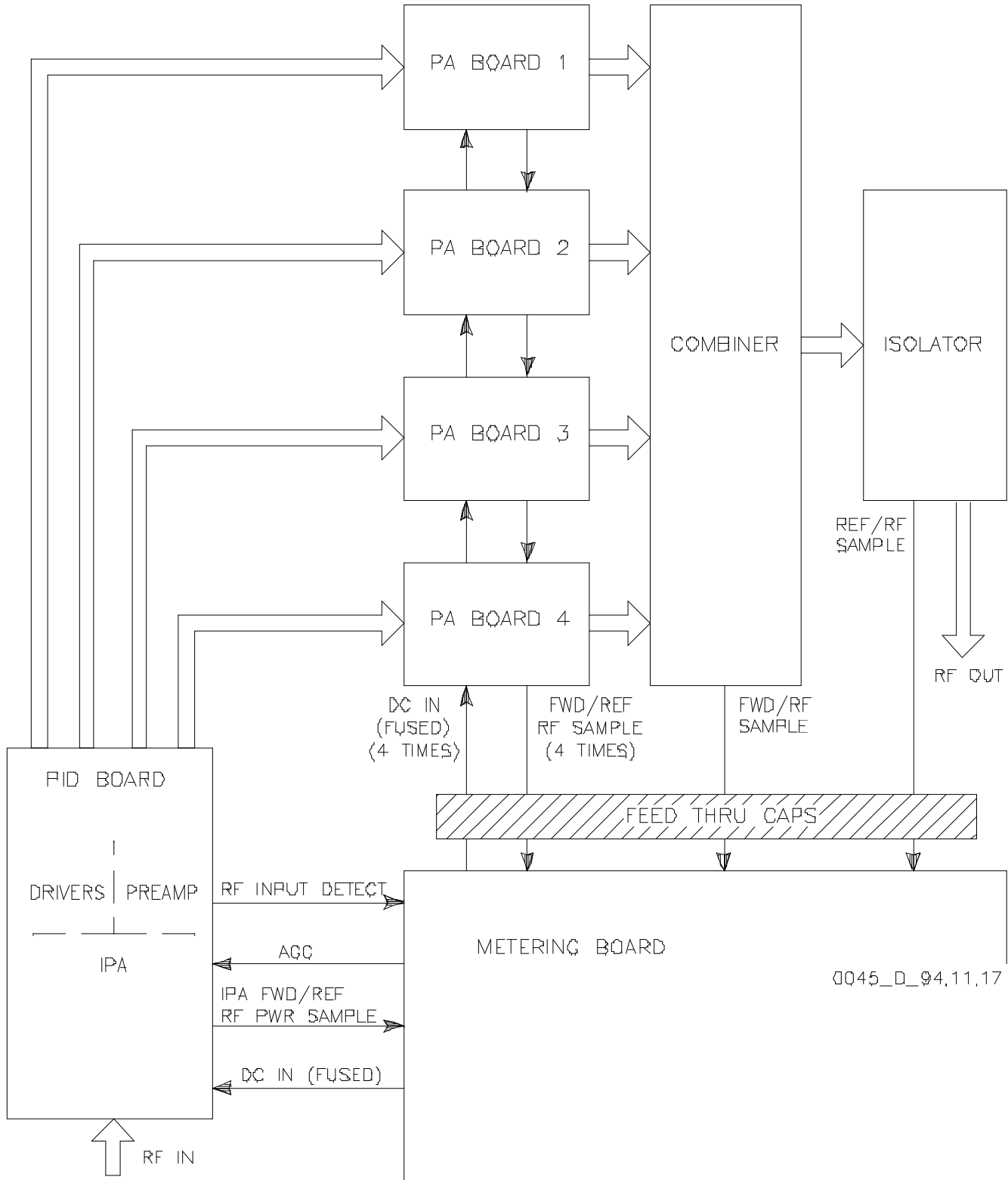

Figure 3-3 Simplified Block Diagram

4 INSTALLATION AND SETUP

4.1 Precautions and Hazards

Caution

Pc boards within this assembly use static-sensitive components. Follow IC-handling precautions.

DANGER

The PA chassis is not protected by interlocks. Disconnect ac power before removing any covers.

4.2 Test Equipment and Tools Required

Refer to *Figure 4-1*. Equipment listed by brand name may be substituted with equivalent. Common hand tools are required for assembly and disassembly. An RFI-immune voltmeter is required for voltage measurement.

Table 4-1 Test Equipment Required

item	description
tuning tool	Johanson 8777 or equivalent
RF power meter	Bird model 8327 or equivalent with appropriate RF adapters
voltmeter	Fluke model 77 DVM or equivalent
RF dummy load	50-ohm load
screwdriver	Phillips

4.3 Installation

The PA is shipped already installed in a cabinet. To remove or reinstall the PA, refer to Section 9.

4.3.1 Rack Positioning

Rackup variations are generally not possible. Cooling and cabling restraints require that equipment pieces remain racked as shown. Detailed descriptions or equipment mounting and installation procedures are given in the various equipment user manuals.

The equipment rack can be placed with its back or sides close to another object since it ventilates through the front and top. However, to gain reasonable access to the back, 30 inches of free space should be allowed. The top and front of the rack should have at least ten inches of free space. The cabinet should be placed as close as possible to the transmitting antenna, and to the primary power source as a secondary consideration.

Caution

Never place the rack where moisture, steam, condensation, or standing water, can come in contact with it. The host room may need to be air conditioned or additionally ventilated to remove excess heat generated by this equipment.

4.3.2 Rack Grounding

The rack cabinet must be connected to a reliable earth ground. Connect the earth ground point to a ground point provided in the rack; use four-gauge or larger copper conductor.

4.3.3 Equipment Inspection

Inspect the equipment to be certain that the equipment rack is complete. Compare items received to the packing list. Report shipping loss or damage to carrier within 15 days of receipt. Remove any packing material from the rack and check each assembly. Pay particular attention to the power supply; check it closely and remove any foreign material in the chassis. Be certain to disconnect primary power from the power supply before removing any equipment covers.

4.3.4 Equipment Cabling

Refer to section four in PN 9110.00163, GL-T8500/GL-T8600 System Manual, for equipment cabling information.

4.3.5 Equipment Mounting

Refer to *Figure 3-1* for information on mounting the PA assembly to the equipment rack.

4.3.6 Ultimate Disposition

Caution

This equipment may contain hazardous materials. Check with the local EPA or other environmental authority before disposing of this equipment.

4.4 Setup

Setup of the PA is performed at the system level using an exciter/PA control unit. Refer to the GL-T8600 system manual. The system manual includes instructions for these applicable setup procedures:

- adjust forward power
- set low power alarm
- calibrate reflected power

5 OPERATION

5.1 Controls and Indicators

The PA has one indicator and no controls. Figure 5-1, Front-Panel View with Cover Removed, shows the location of the PA indicator LED1.

5.2 Operation

5.2.1 Turn PA On and Off

The PA does not contain an on/off switch, but turns on and off whenever the power supply equipment is turned on and off. When the PA is on, it remains in a standby condition until keyed. Refer to the power supply manual for turn-on and turn-off procedures.

5.2.2 Turn Fan On and Off

The fan does not contain an on/off switch, but turns on and off whenever the power supply equipment is turned on and off. The fan runs continuously whenever the power supply equipment is on. Refer to the power supply manual for turn-on and turn-off procedures.

5.2.3 Key and Unkey PA

The PA does not contain a key switch, but is keyed and unkeyed by the exciter/PA control equipment. This exciter must be keyed and unkeyed remotely through transmitter controller, or locally through a video display terminal (VDT). Refer to the controller manual for remote key and unkey instructions, or to the VDT manual for local key and unkey instructions.

v0424.hgl

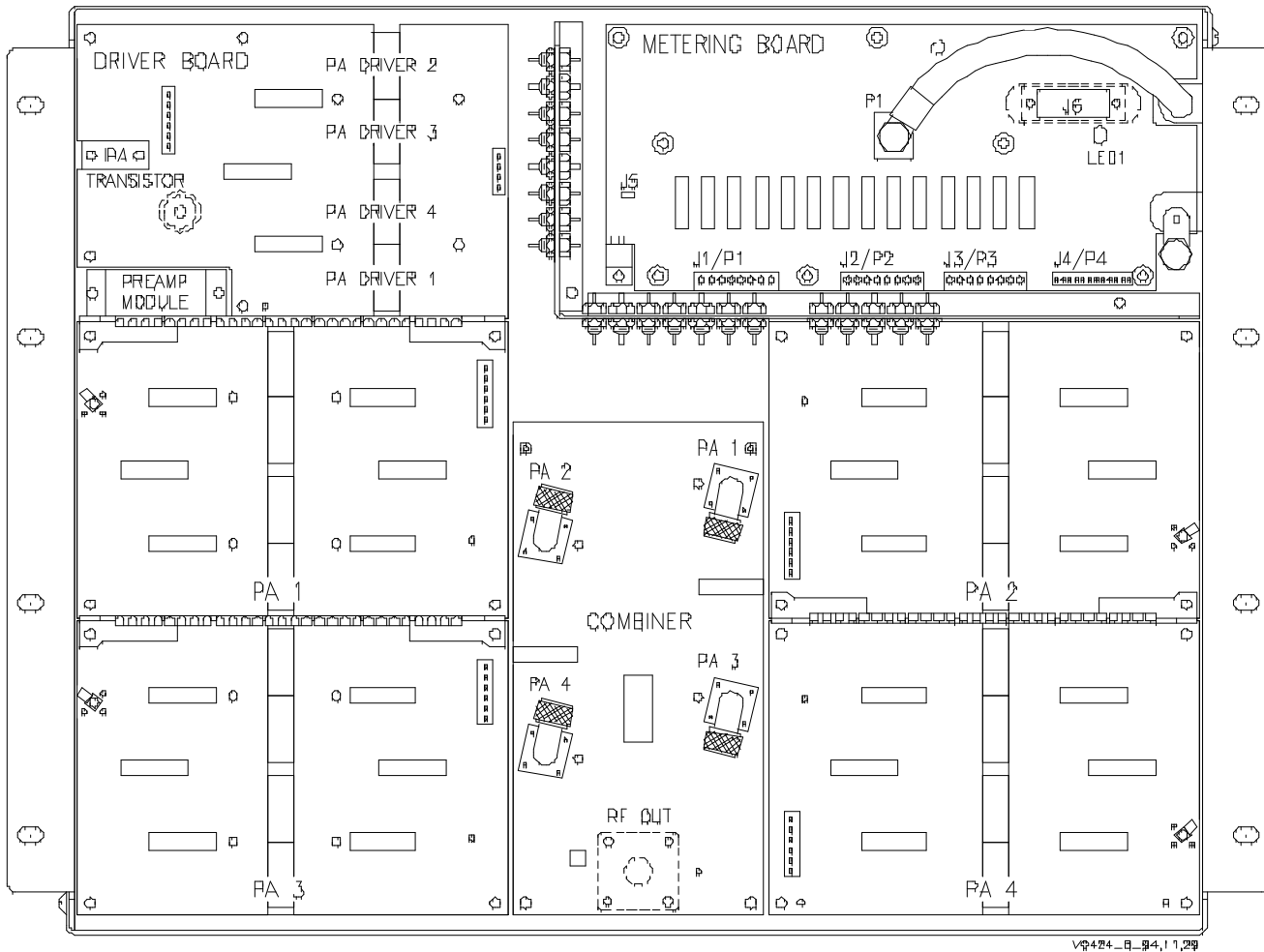

Figure 5-1 Front-Panel View with Cover Removed

6 THEORY OF OPERATION

6.1 Power Distribution

The PA requires three separate power inputs: primary 25-volt dc power, secondary 13.5-volt dc power, and fan 25-volt dc power. All power inputs are normally provided by the Gold Line power supply.

6.1.1 Primary Power

Refer to *Figure 6-2*. Primary 25-volt dc operating power is received through the power cables terminating with 1/4-inch ring lugs. The (-) input (black cable) is bolted directly to PA chassis ground. The (+) input (red cable) is bolted to P1 on the metering board. P1 powers the +25V power bus on the metering board. This bus distributes primary power to the metering board and to each common-base collector (CBC) power amplifier in the PA.

6.1.1.1 Metering Board +25V Signal Flow

Refer to *Figure 6-4*. +25 volts from the power bus is supplied through fuse F13 to these places on the metering board: LED1, +25V components, divider circuitry, +5V regulator and divider circuitry, and +1.2V regulator circuitry.

- LED1 activates to illuminate the DC POWER indicator on the front of the PA.
- +25V components receive operating power. These components include the current detector amplifiers.
- Divider circuit reduces the input to a sample voltage, which determines the PA 25V metering.
- +5V regulator/divider circuitry generates +5V operating power for the metering board +5V components. A portion of this +5V is reduced to a sample voltage, which determines the PA 5V metering.
- +1.2V regulator circuitry generates the compensation voltage for the current detector amplifiers.

6.1.1.2 Power Amplifiers +25V Signal Flow

Refer to *Figure 6-1*. +25 volts operating power from the power bus is paralleled through seven resistors. These resistors are a component of a current detection circuit.

Current-Detection Theory

Current-detection monitoring occurs on the metering board. The monitored current is routed through a small resistor, resulting in a slight voltage drop across the resistor. This voltage drop is amplified by a current detector amplifier, which generates an output voltage proportional to the current flowing through the resistor. This output voltage is the current sample for the monitored current.

The seven monitored +25-volt signals are individually fused before leaving the metering board. The signals provide operating power for power amplifiers located on the driver and PA boards. Each signal is routed through a dc bias network.

Dc-Bias Network Theory

Dc bias networks are located on the driver board and PA boards. +25-volt operating power from the metering board is applied to the power amplifiers through a dc bias network. The network is tuned and filtered to cause a high impedance to signals from dc to above operating frequency. This prevents RF from transmitting backwards into the metering board.

6.1.2 Secondary Power

Secondary 13.5-volt dc power for the PA is externally fused, at the power supply equipment. Refer to *Figure 6-1*. Secondary power is received through connector P2, which mates with J2 on the system interconnect harness. Secondary power is connected to J5 on the metering board. The +13.5 input from J5 is distributed to the metering board and the preamp module.

6.1.2.1 Metering Board +13.5V Signal Flow

Refer to *Figure 6-2*. +13.5-volt power from J5 is paralleled to these places on the metering board: +13.5V components, divider circuitry, and heat sink temperature transducer U17.

- +13.5V components receive operating power. These components include those within the AGC integrator circuit.
- Divider circuit reduces the input to a sample voltage, which determines the system PA 13.5V metering.
- Heat-sink-temperature transducer U17 generates a voltage proportional to the temperature of the PA heat sink, which determines the temperature metering.

6.1.2.2 Preamp Module +13.5V Signal Flow

Refer to *Figure 6-2*. +13.5-volt power from J5 is routed through a resistor, a component of a current-detection circuit. The sample provided by this circuit determines the preamplifier current metering. The +13.5-volt power through the resistor is fused by F4 before distribution to the metering board and preamplifier module, on the driver board.

6.1.3 Fan Power

25-volt dc fan power is fused externally at the power supply equipment. Refer to *Figure 6-1*. Fan power is received through connector P2, which mates with J2 on the system interconnect harness. Fan power is applied directly to the fan via a quick-release jack (not shown).

6.2 RF Distribution

Refer to *Figure 6-1*. The PA RF input is received through a BNC connector, which mates with J3 on the exciter/PA control. This RF input signal (at a nominal 350 mW) is split and amplified into two RF signals (at a nominal 40 watts) by the driver board. Each RF signal is amplified (to a nominal 150 watts) by a PA board. These RF signals are combined into one RF signal (at a nominal 550 watts) by the combiner board. This is the PA RF output, and is applied to an isolator. The isolator RF output (at a nominal 500 watts for standard) is supplied to an antenna for transmission. All power levels given here and in the following paragraphs are typical; actual power levels will vary from those given.

6.2.1 Driver Board RF Flow

The driver board splits and amplifies a 350-mW RF input into four 40-watt RF outputs. Refer to *Figure 6-3*. The RF input to the driver board is applied to the preamplifier module (Q1). A portion of the RF input is applied to an RF-detection circuit on the board. This circuit rectifies and filters the RF input into an OK signal. Loss of the RF input and the OK signal results in an exciter output fault.

The preamplifier module is a three-stage RF power amplifier on a single IC. The first and third stages are powered by an AGC signal. These are the variable gain stages, and control the forward power output of the PA. The first and third stages of the preamp module are powered by an AGC signal, generated on the metering board. AGC signal voltage is monitored for status only. The second stage of the preamplifier module is a nonvariable-gain stage, powered by +13.5-volt power. The current drawn by the AGC and +13.5-volt power signals contributes to the preamplifier current metering.

The amplified RF output from the preamp module is applied to the IPA (Q2). The current drawn from the IPA's +25-volt power source is monitored to determine the IPA current metering. The amplified RF output from the IPA is monitored for forward and reflected power levels. The power samples detected at this location determine the IPA forward - and reflected-power metering.

Power-Monitoring Theory

Power-monitor circuits are located on the driver board, PA boards, and combiner board. A microstrip line parallel to the RF signal path couples a small portion of the ac signal across a rectifier and filtering circuit. The ac signal may be rectified to detect either the forward or reflected power. After filtering, a dc sample voltage is available that is proportional to the power detected at the monitored location.

After monitoring, the amplified RF output from the IPA is split in four by means of an RF splitter, commonly known as a Wilkinson splitter. The four split RF signals are applied to driver-1 (Q3), driver-2 (Q4), driver-3 (Q5), and driver-4 (Q6). The current drawn from each

driver's +25-volt power source is monitored to determine the driver-1, driver-2, driver-3, and driver-4 current metering. The amplified RF outputs from the four drivers are the driver board's 40-watt RF outputs.

Wilkinson Splitter/Combiner Theory

Wilkinson splitter and combiner networks are located in the RF signal path on the driver board, PA boards, and combiner board. A waster resistor is located a precise distance from the signal junction. This resistor dissipates any out-of-phase imbalance or amplifier imbalance that may exist between the RF signals being split or combined, resulting in a more stable amplifier.

6.2.2 PA Board RF Flow

Each PA board amplifies a 40-watt RF input into a 150-watt RF output. Refer to *Figure 6-3*. The RF input to the PA board is split into four signals by means of three Wilkinson splitters. Each RF signal drives a power amplifier, for a total of four amplifiers (Q1, Q2, Q3, and Q4). Q1 and Q2 receive operating power from a common +25-volt power source. The current drawn by this source is monitored to determine the PA board's A-pair current. Likewise, the current drawn by Q3 and Q4 common +25-volt power source is monitored to determine the PA board's B-pair current.

The amplified RF outputs from the four power amplifiers are combined into one by means of three Wilkinson combiners. The RF signal from the last Wilkinson combiner is monitored for forward and reflected power levels. The power samples detected at this location determine the PA board's forward and reflected power metering. The combined and monitored RF signal is the PA board's 150-watt RF output.

6.2.3 Combiner Board RF Flow

The combiner board combines four 150-watt RF inputs into a single 550-watt RF output. Refer to *Figure 6-3*. The four RF inputs are combined by a Wilkinson combiner. The combined RF is monitored for forward power level. The power sample detected at this location determines the total forward power metering. The combined and monitored signal is the combiner board's 550-watt RF output.

6.2.4 Isolator RF Flow

The isolator conducts its 550-watt RF input only in the forward direction, suppressing any intermodulation or VSWR present at its RF output. Refer to *Figure 6-3*. The RF input is applied through a circulator. The optional triple isolator RF input is applied through three circulators.

Circulator Theory

A circulator consists of several circular layers of copper, ferrite, and a magnetic material that biases the ferrite. The circulator has three inputs/outputs. The biased ferrite conducts electricity only in one direction, outputting the signal applied at its previous input. Each circulator provides 25 dB of isolation.

The circulator RF output is applied through a notch filter to remove the second harmonics generated by the circulator. This filtered RF is the isolator's RF output. This RF output is typically 500 watts for a standard isolator. Any reflected power present at the isolator RF output is conducted back through the circulator to a rectifier and filtering circuit. This circuit generates a dc sample voltage proportional to the VSWR present at the isolator RF output. The sample voltage determines the total reflected-power metering.

6.3 Control Distribution

Refer to *Figure 6-1*. The PA control inputs are received through a DB15 connector, which mates with J6 on the exciter/PA control. Two types of control inputs are received: AGC reference and multiplexer.

6.3.1 AGC Signal Flow

The metering board compares the AGC reference signal (from the exciter) with the total forward power sample (from the combiner board) to create an AGC signal (to the driver board). Refer to *Figure 6-2*. The AGC reference signal and the total forward power sample are applied to an integrator circuit, which generates the AGC signal. An increase in the AGC reference signal or a decrease in the total forward power sample causes an increase in the AGC signal. This AGC signal provides operating power for the first and third amplifier stages of the preamplifier. Divider circuitry reduces a portion of the AGC signal to a sample voltage, which determines the AGC metering.

6.3.2 Multiplexer Control Signal Flow

Analog Multiplexer Theory

Three analog multiplexers are located on the metering board. Each multiplexer receives as many as eight analog inputs, at a sample voltage which represents a PA parameter or status. Control lines from the exciter command the multiplexer to connect one of the inputs to a common output, which is measured by the exciter. The multiplexer is switched quickly between the analog inputs, resulting in a multiplexed analog output.

Refer to *Figure 6-2*. The exciter controls each multiplexer by four control lines: three address lines and a latch. The address lines (0, 1, and 2) are binary signals with a total of eight possible states. The address lines sequence through the eight states in about 360 microseconds. As each state occurs, the latch line is toggled, selecting the analog input corresponding to that address state. The voltage present at the multiplexer common output is the most recently latched analog input.

6.4 Status Distribution

Refer to *Figure 6-1*. The PA status outputs are supplied through the same DB15-type connector as the PA control inputs, which mates with J6 on the exciter/PA control. Two types of status outputs are supplied: multiplexed (mux) analog and PA fault.

6.4.1 Mux Analog Status Signal Flow

Mux analog status signals consist of dc voltages that represent a parameter or fault within the PA. These signals are generated by current detectors, power monitors, and metering dividers, which supply a status voltage proportional to the level of parameter it is representing, or the existence of the fault it is representing. Refer to *Figure 6-2*. These status voltages are applied to one of the three multiplexers located on the metering board. The multiplexers route the appropriate status voltage to the exciter in the form of mux analog. *Table 6-1* lists all status voltage nomenclature, the multiplexer that routes that voltage, and the control address that directs the multiplexer to route that voltage.

6.4.2 PA Fault Signal Flow

A PA fault signal is activated when a reflected power threshold is exceeded by the PA1, PA2, PA3, and PA4 board. Refer to *Figure 6-2*. A portion of the PA1, PA2, PA3, and PA4 board reflected power status voltages are applied to a comparator and switching circuit. When either status exceeds a voltage representing about 20 watts, the switch is activated. The switch applies a PA fault to the exciter, which shuts down the transmitter.

Table 6-1 Multiplexer Analog Status Inputs

addr	multiplexer 1	multiplexer 2	multiplexer 3	multiplexer 4
000	PA1-A current	PA1 forward power	+13.5V voltage level	AGC voltage level
001	PA1-B current	PA1 reflected power	IPA current	(no input)
010	PA2-A current	PA2 forward power	driver-1 current	IPA forward power
011	PA2-B current	PA2 reflected power	driver-2 current	IPA reflected power
100	PA3-A current	PA3 forward power	driver-3 current	(no input)
101	PA3-B current	PA3 reflected power	driver-4 current	(no input)
110	PA4-A current	PA4 forward power	exciter output fault	(no input)
111	PA4-B current	PA4 reflected power	AGC voltage level	(no input)

v0412.bgl

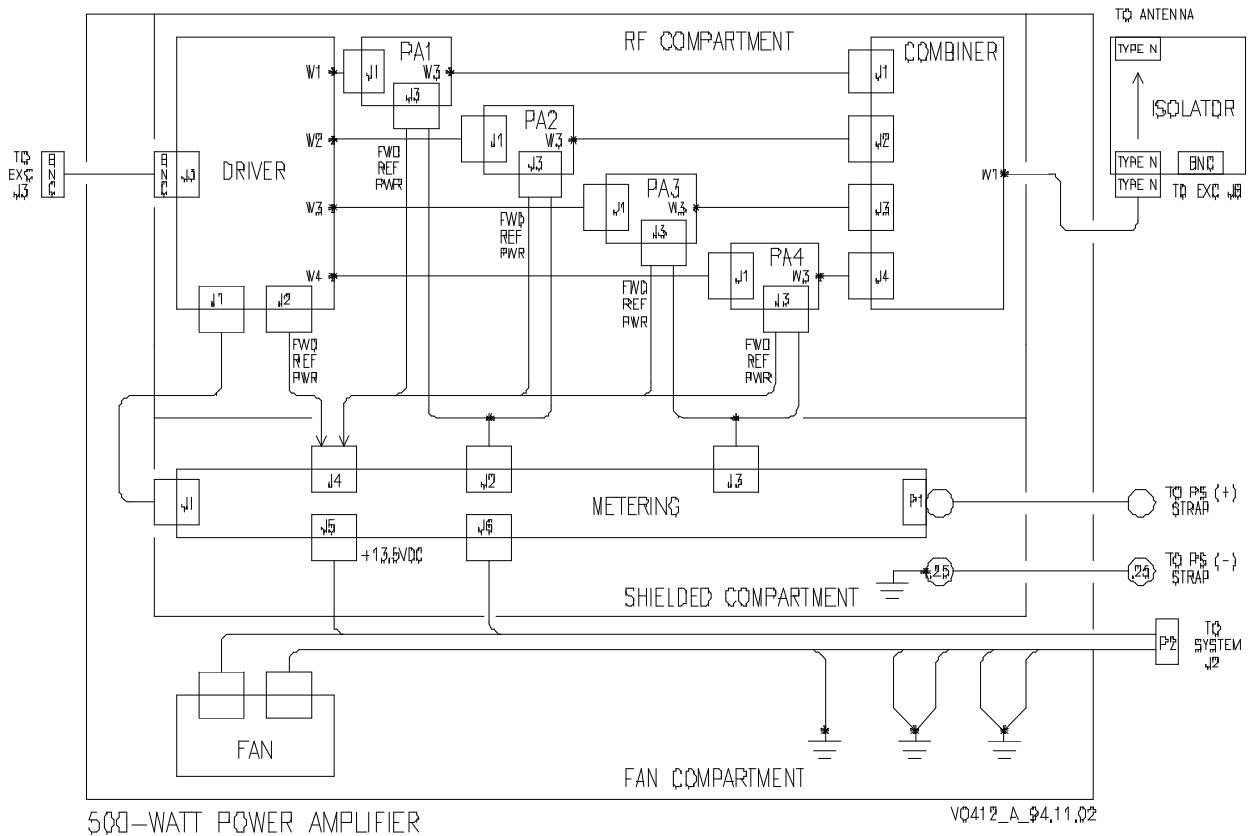

Figure 6-1 500-Watt PA Interconnection Diagram

v0411.hgl

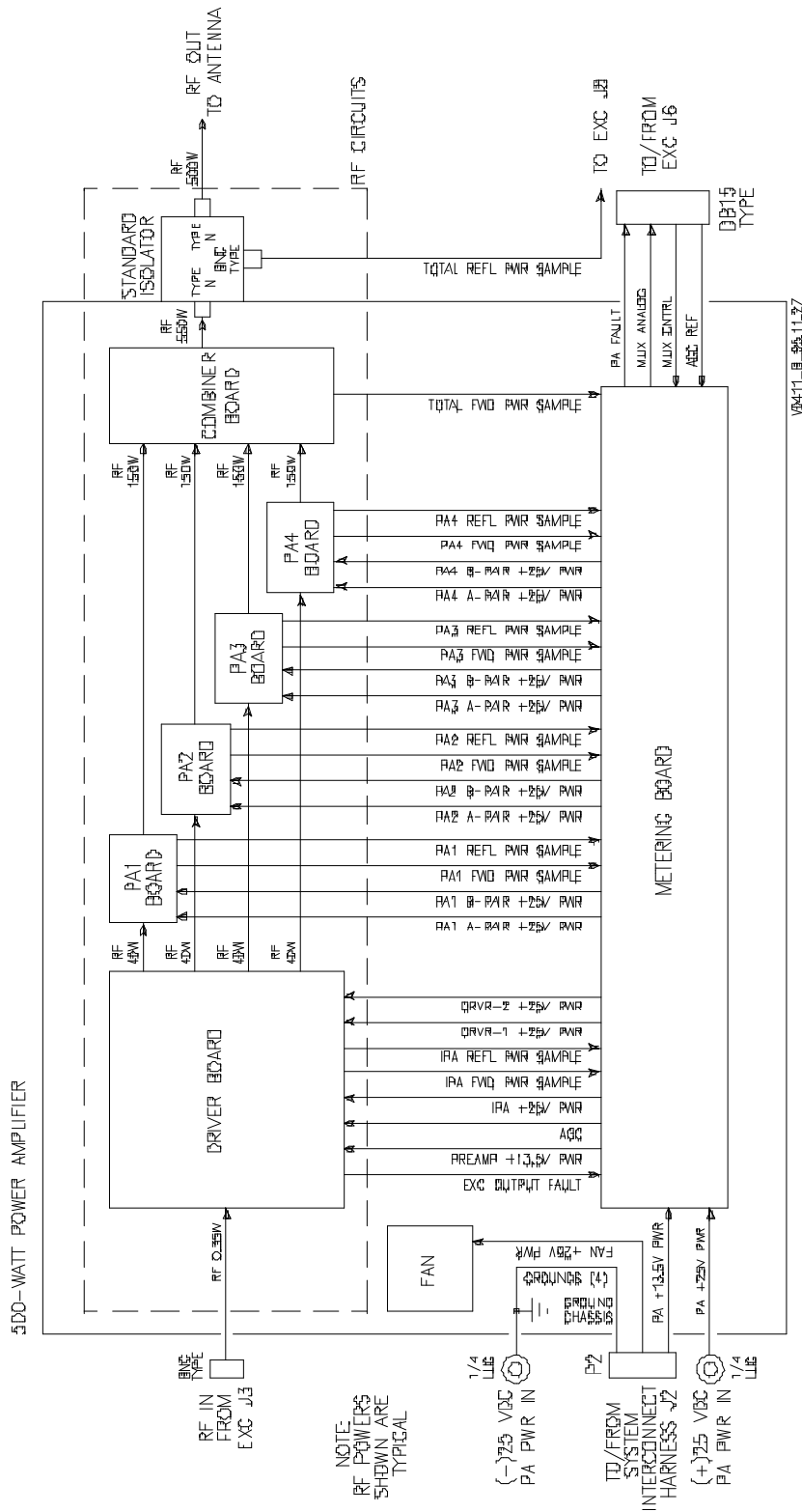

Figure 6-2 500-Watt PA Functional Diagram

v04101.hgl

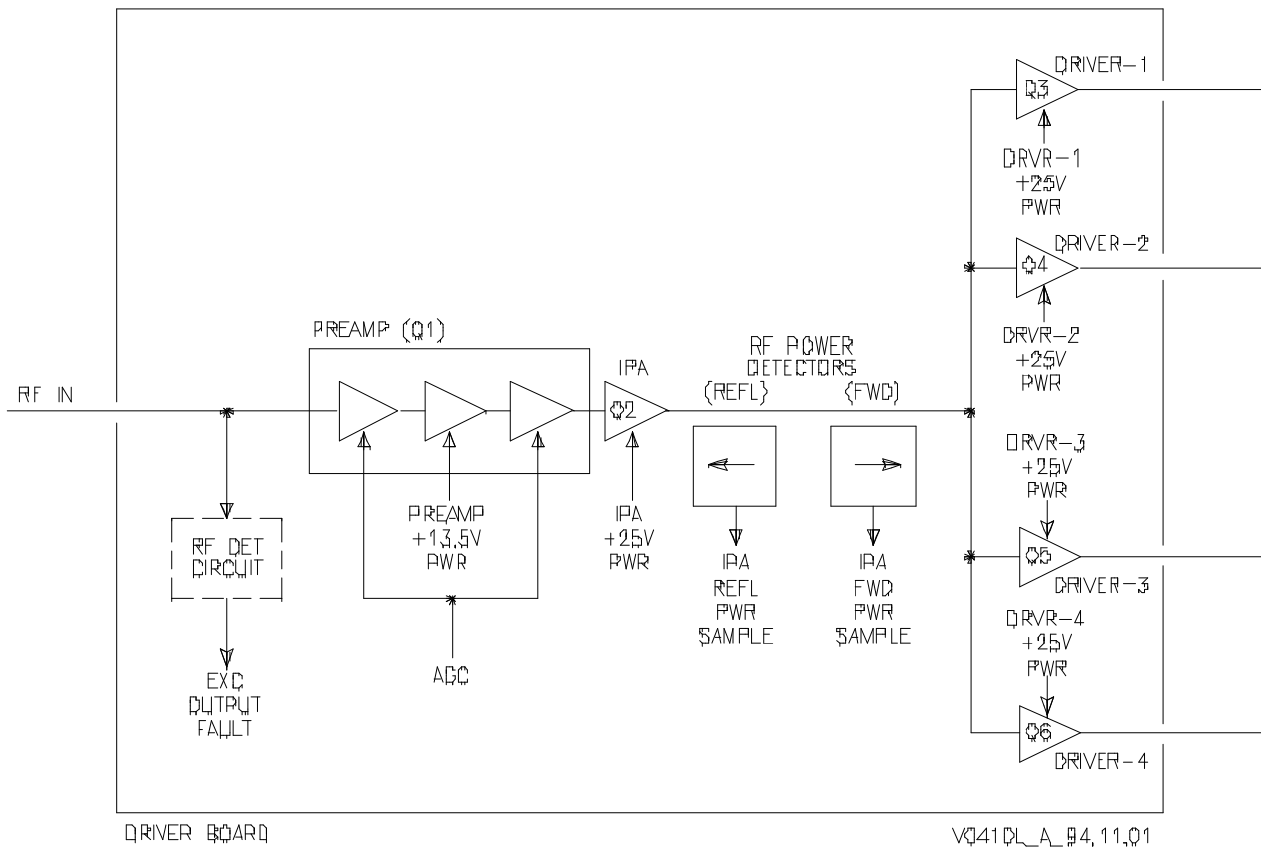

Figure 6-3 500-Watt PA Detailed Functional Diagram

v0410r.hgt

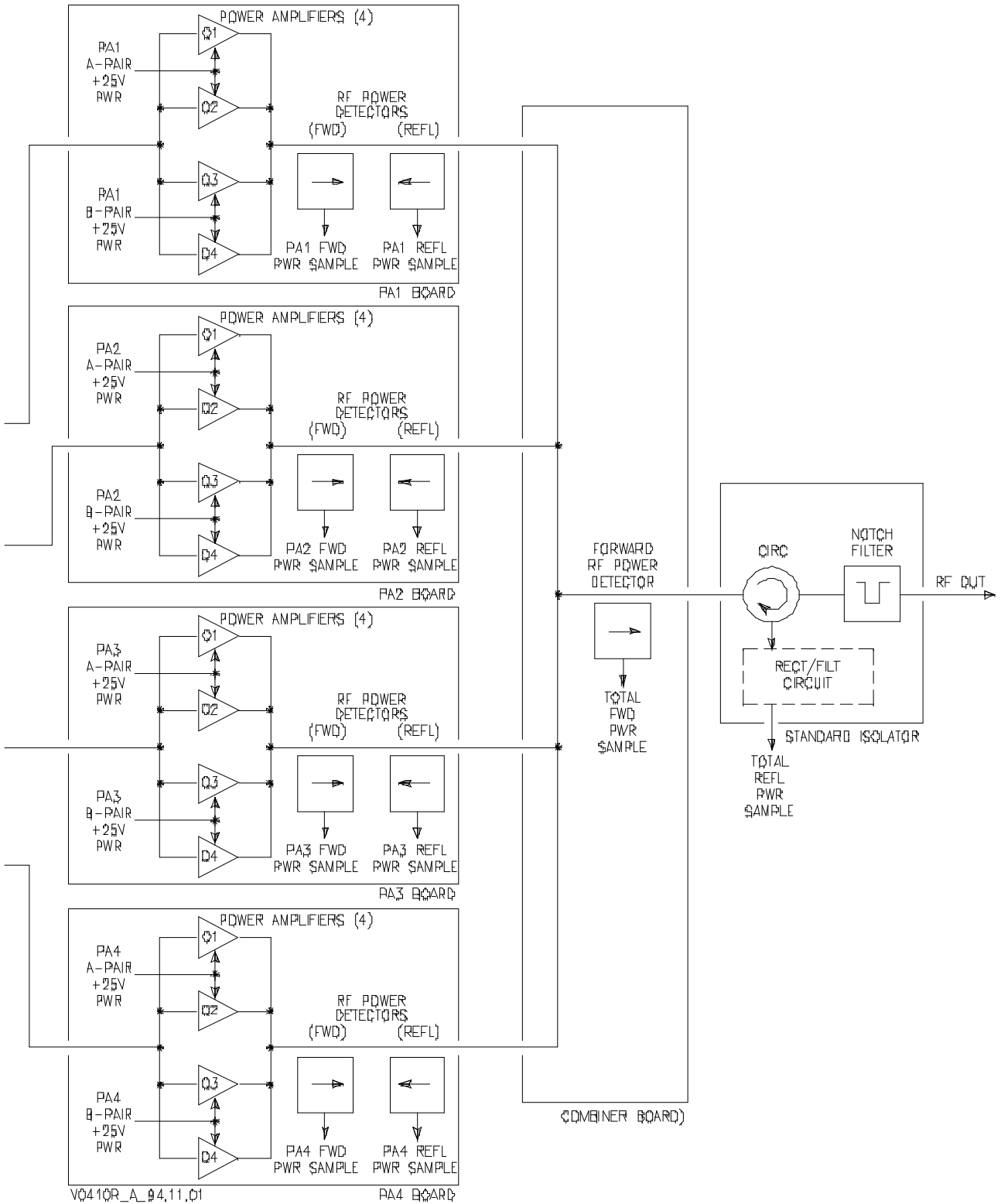

Figure 6-3 500-Watt PA Detailed Functional Diagram (continued)

v0057.bgl

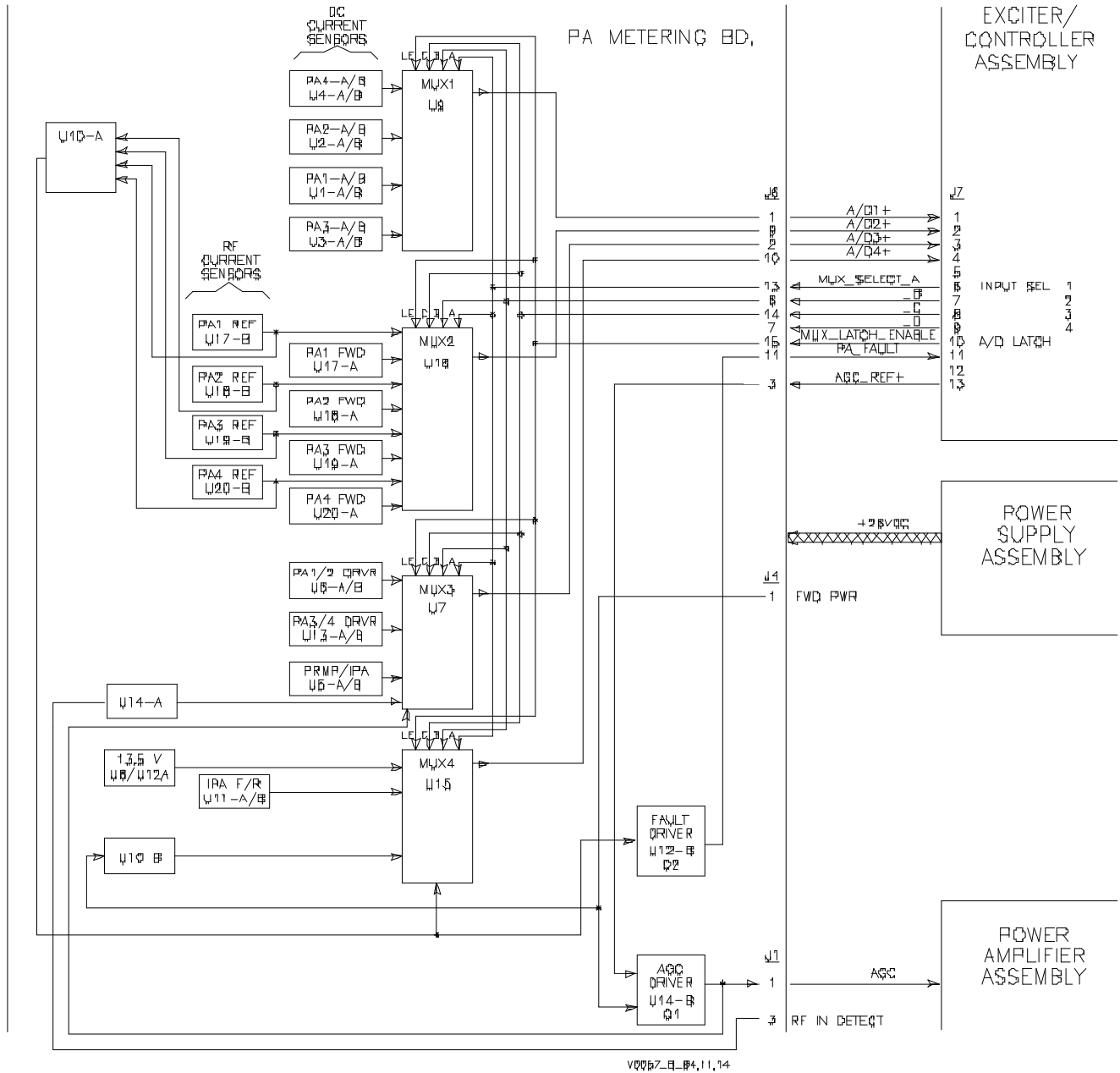

Figure 6-4 Metering Board Functional Diagram

7 MAINTENANCE

Refer to the system and VDT manuals.

8 CHECKOUT AND TROUBLESHOOTING

Refer to the system and VDT manuals.

9 REMOVAL AND REINSTALLATION

9.1 PA Chassis Removal and Reinstallation

Figure 9-1 shows details of removing and reinstalling the chassis. Calibration of forward and reflected power is required after reinstallation.

9.2 PA RF Module Removal and Reinstallation

Figure 9-2 shows details of removing and reinstalling PA RF modules.

9.3 Metering Board Removal and Reinstallation

Figure 9-3 shows details of removing and reinstalling the metering board.

v0223.hgl

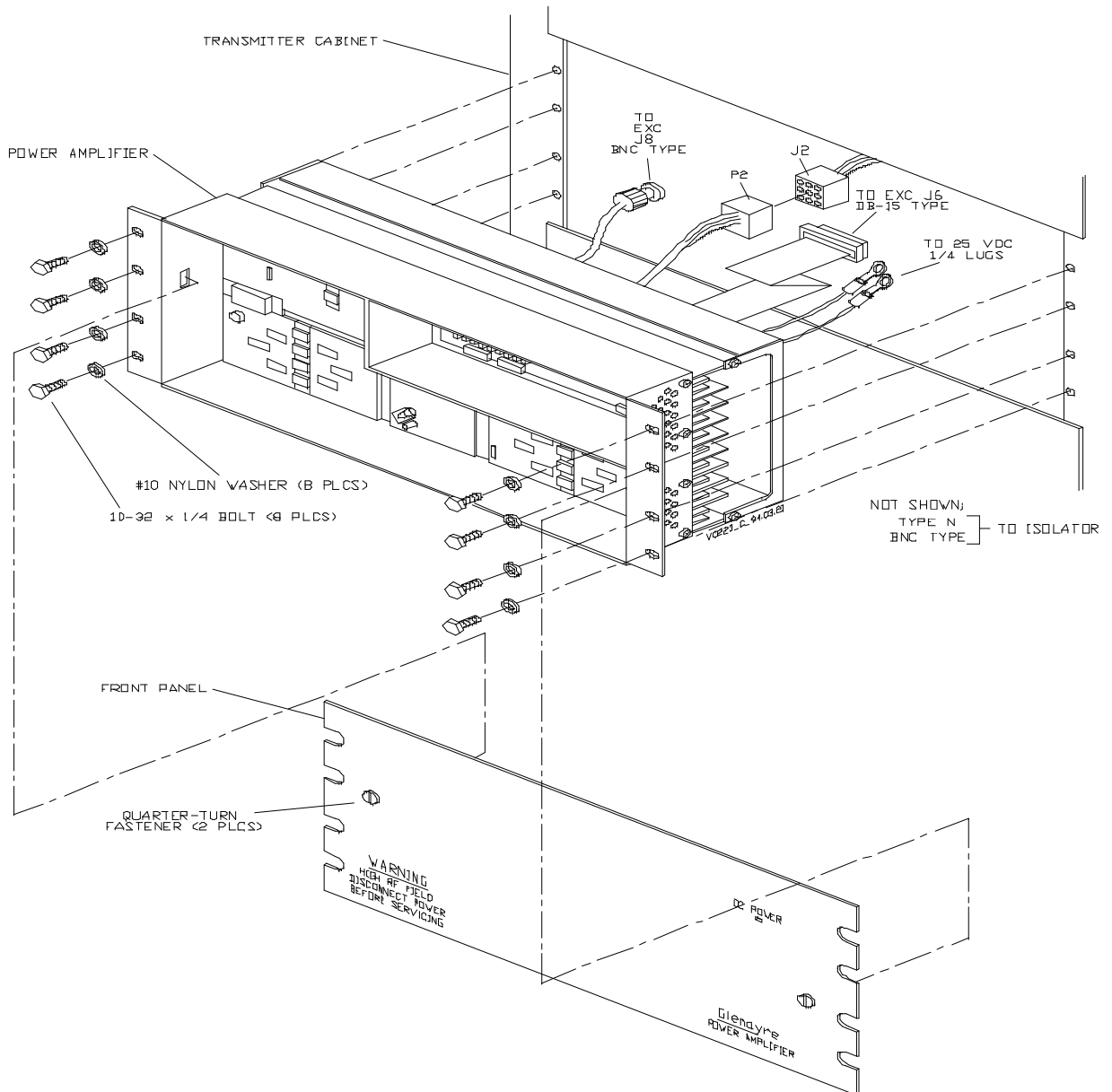

Figure 9-1 PA Removal and Reinstallation

v0225.hgt

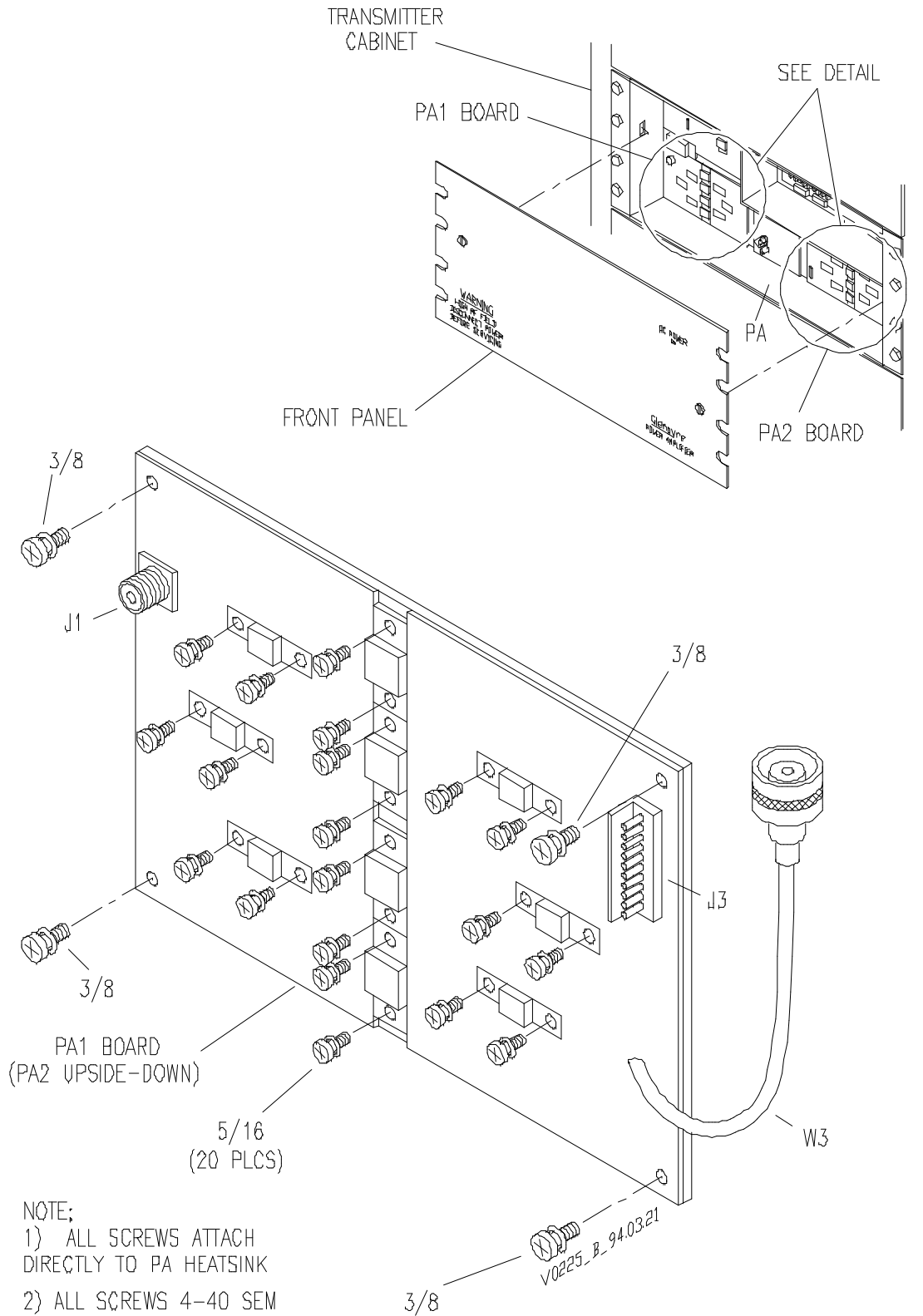
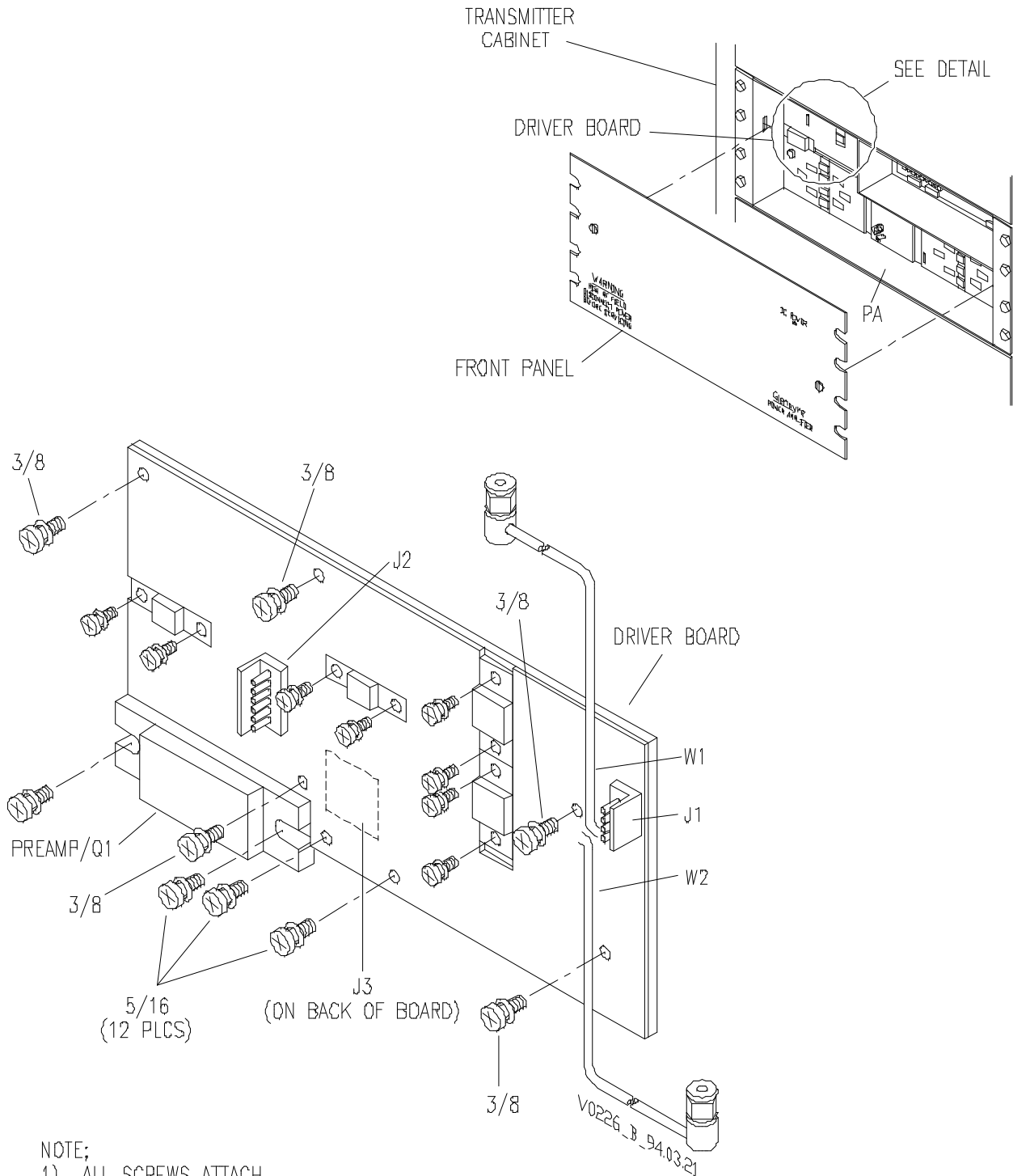

Figure 9-2 PA RF Module Removal and Reinstallation



NOTE;
1) ALL SCREWS ATTACH
DIRECTLY TO PA HEATSINK
2) ALL SCREWS 4-40 SEM

Figure 9-2 PA RF Module Removal and Reinstallation (continued)

v0228.hgl

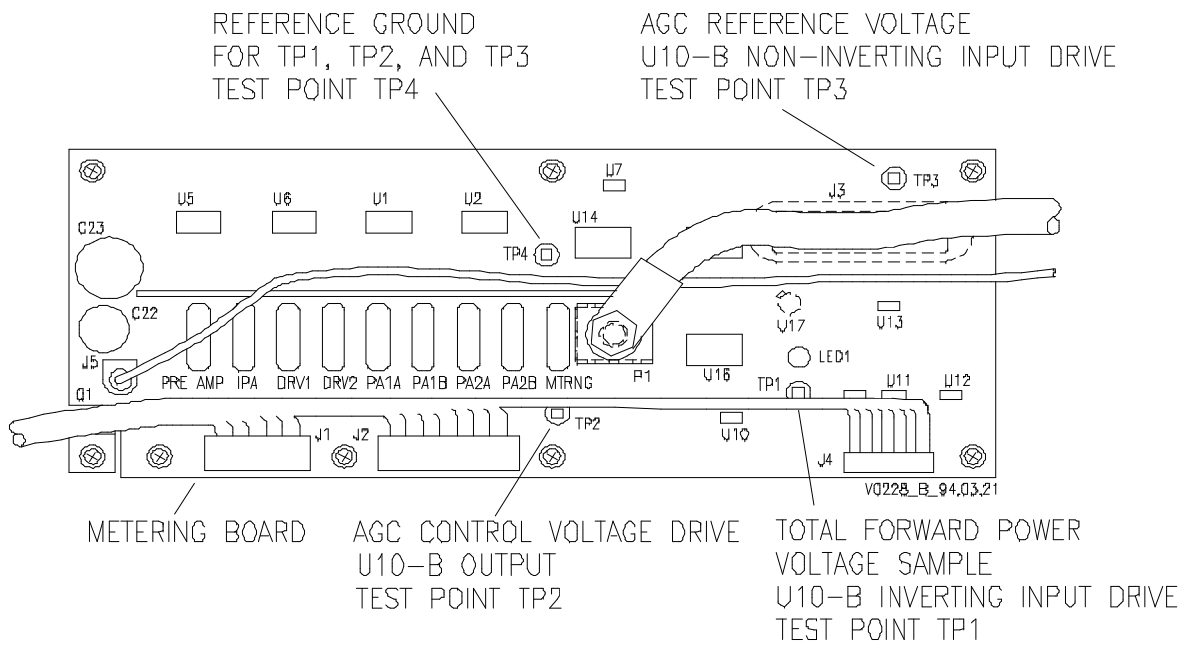
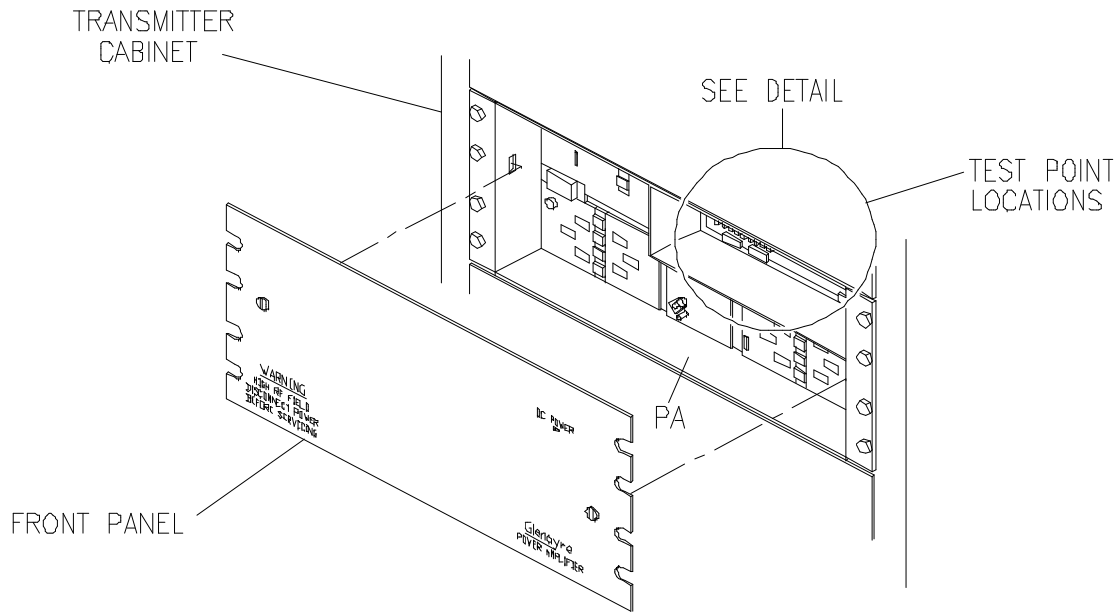
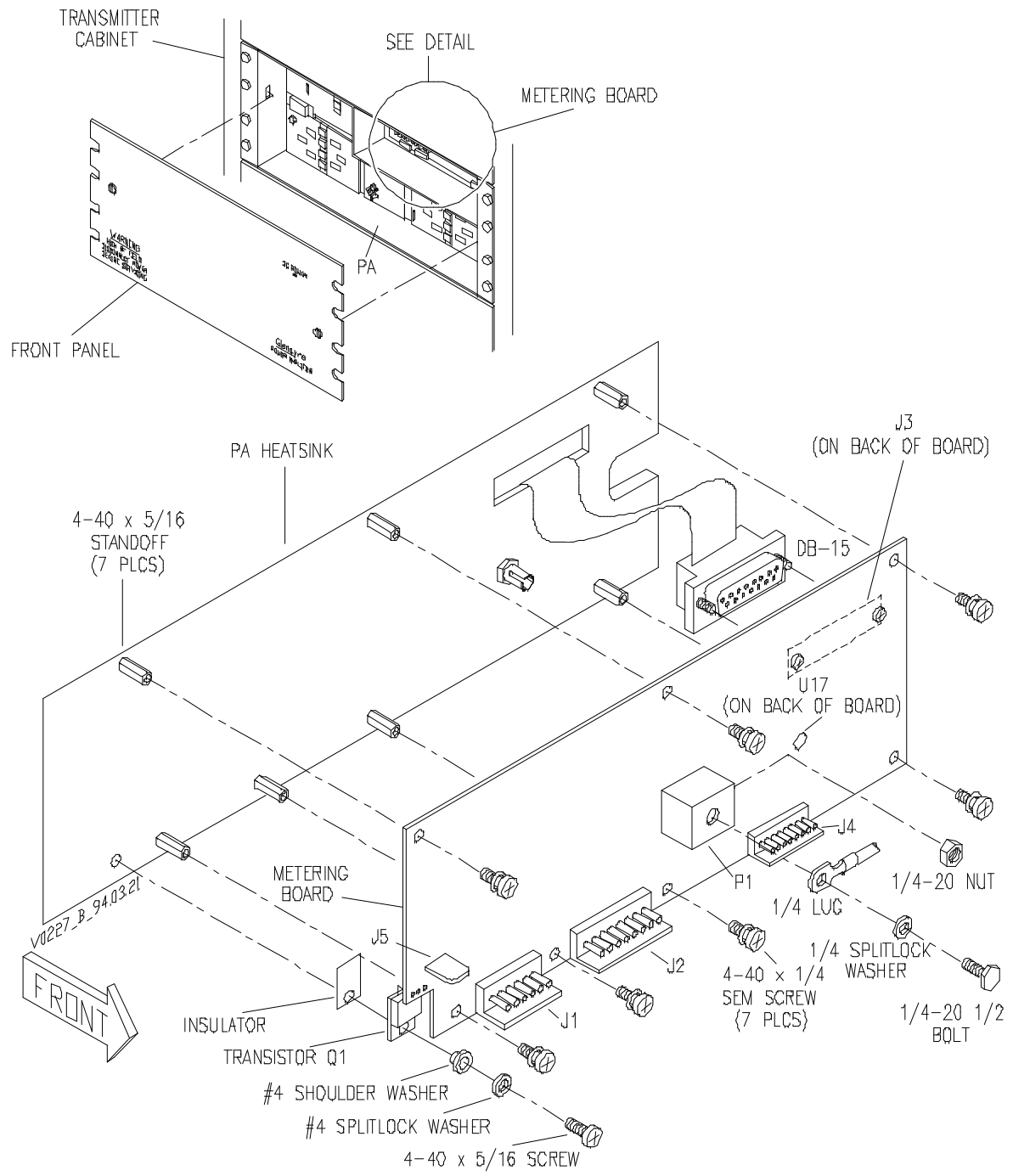

Figure 9-3 Metering Board Removal and Reinstallation

v0227.hgl



Metering Board Removal and Reinstallation (continued)