



VHF ENHANCED TRANSMITTER INSTRUCTION MANUAL

VHF 29 - 50 MHz

Covers Models:

VT-3H035-SXA300

VT-3H045-SXA300

Copyright © 2007 Daniels Electronics Ltd. All rights reserved. No part of this publication may be reproduced, stored in a retrieval system or transmitted in any form or by any means, electronic, mechanical, photocopying, recording or otherwise, without the prior written consent of Daniels Electronics Ltd.

The stylized "Daniels Electronics Ltd." and "DE" logo are registered Canadian and US trademarks of Daniels Electronics Ltd.

The stylized "Daniels Electronics Ltd." and "DE" logo are trademarks of Daniels Electronics Ltd.

Module Manuals included:

IM20-MT3TXMN Transmitter Main Board

IM20-VT3040AMP Transmitter Amplifier

IM10-OS3AH MT-3 Synthesizer

IM20-VT3H040CT Channel Designation Table

Document Number:
Revision:
Revision Date:

IM20-VT3H040
1-1-2
July 2008

Daniels Electronics Ltd.
Victoria, BC
PRINTED IN CANADA

DOCUMENT CONTROL | This document has been produced, verified and controlled in accordance with Daniels Electronics' Quality Management System requirements.

Please report any errors or problems to Daniels Electronics' Customer Service Department.

DOCUMENT REVISION DEFINITION | Daniels Electronics Ltd. utilizes a three-level revision system. This system enables Daniels to identify the significance of a revision. Each element of the revision number signifies the scope of change as described in the diagram below.

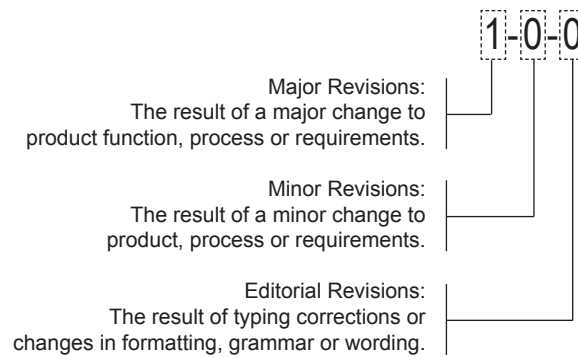

Three-level revision numbers start at 1-0-0 for the first release. The appropriate element of the revision number is incremented by 1 for each subsequent revision, causing any digits to the right to be reset to 0.

For example:

If the current revision = 2-1-1 Then the next major revision = 3-0-0

If the current revision = 4-3-1 Then the next minor revision = 4-4-0

If the current revision = 3-2-2 Then the next editorial revision = 3-2-3

The complete revision history is provided at the back of the document.

NOTE | The user's authority to operate this equipment could be revoked through any changes or modifications not expressly approved by Daniels Electronics Ltd.

The design of this equipment is subject to change due to continuous development. This equipment may incorporate minor changes in detail from the information contained in this manual.

Contents

| | |
|--|----|
| General Information | 1 |
| Introduction | 1 |
| Manual Organization | 2 |
| VT-3H040 Transmitter Family Models..... | 2 |
| Performance Specifications | 3 |
| Audio Specifications..... | 4 |
| Physical Specifications | 4 |
| System Overview | 5 |
| Transmitter Operation | 5 |
| Frequency Selection | 6 |
| Transmitter Assembly and Adjustment..... | 7 |
| Complete Transmitter Alignment | 7 |
| Frequency Change | 7 |
| Output Power Adjustment..... | 8 |
| Deviation Setting | 8 |
| Setting RF Alarm Thresholds..... | 8 |
| Recommended Test Equipment List | 8 |
| Repair Note..... | 8 |
| Illustrations and Schematics | 9 |
| VHF Enhanced Transmitter Front Panel | 10 |
| VHF Enhanced Transmitter Case Removal | 10 |
| VHF Enhanced Transmitter Block Diagram | 11 |
| Parts Lists | 13 |
| Mechanical Parts List..... | 13 |
| Revision History | 15 |



GENERAL INFORMATION

INTRODUCTION

The VT-3H040 transmitter is a low power, synthesized FM transmitter capable of operating in 20 kHz or 25 kHz channels and within one of two bands: 29 MHz to 38 MHz or 38 MHz to 50 MHz. The transmitter is rated for continuous duty at an RF output power of 3.0 W. The RF output power level is preset at the factory. A modular design allows each of the transmitter's modules; MT-3 Transmitter Main Board, MT-3 Audio Processor, VT-3H040 Amplifier and OS-3H040 Synthesizer to be individually assembled and tested. This facilitates construction, tuning, maintenance as well as troubleshooting procedures. The synthesizer module can be programmed to have up to 16 channels exclusive to one frequency band.

The VT-3H040 Transmitter is designed to interface with Daniels Electronics' MT-3 Repeater System while maintaining MT-2 System compatibility. Both radio Systems are characterized by dependable, low maintenance performance under the most severe environmental conditions.

MANUAL ORGANIZATION

The organization of this manual reflects the modular makeup of the VT-3 product line. Each module is fully described within its respective submanual, all of which are contained within this document. In general, each submanual contains:

- 1) A functional description and specification summary
- 2) A detailed technical description (Theory of Operation)
- 3) Assembly, setup and alignment procedures relevant to that particular module.

Note: Material presented in a given “sub-manual” may include information related to other module versions not directly applicable to the VT-3H040 Transmitter family (eg, the OS-3H Synthesizer Instruction Manual covers models from 29 MHz to 512 MHz).

The module manuals are as follows;

Transmitter Manual:

This manual provides an overview of the complete transmitter, manual organization and assembly in terms of the other modules.

MT-3 Transmitter Main Board:

This manual pertains to the audio processor module, transmitter Main Board and Front Panel Board. Most of the user selectable options are accessed within the Transmitter Main Board module, including channel selection. Since all external connections (including power and signal lines) are made to the Transmitter Main Board, most of the material pertaining to transmitter operation and installation is found here.

VT-3H040 VHF Amplifier:

The amplifier module provides the final stages of RF power amplification and harmonic filtering for the transmitter. This manual is intended primarily as a reference since the amplifier module is adjusted at the factory.

OS-3H040 Synthesizer:

This manual pertains to the synthesizer module. Channel selection is described in the ‘Transmitter Main Board’ Manual.

VT-3H040 Channel Designation Table:

This document relates operating frequency to the transmitter channel number.

VT-3H040 TRANSMITTER FAMILY MODELS

The VT-3H040 line of transmitters has a single RF power output rating of 0.5 - 3.0 Watt, with wide band FM (20 kHz or 25 kHz channels) and employs synthesizer based frequency generation. The two basic (i.e. no options added) band specific models of the transmitter are as follows:

VT-3H035-SXA300: 29 MHz to 38 MHz

VT-3H045-SXA300: 38 MHz to 50 MHz

The frequency is determined by the model of synthesizer and by the lowpass filter that is installed in the amplifier module (refer to the VT-3H040 VHF Amplifier manual for details). A group of channels spanning 38 MHz can be accommodated by one of the models providing that the frequency span does not exceed 1.0 MHz. Model VT-3H035-SXA300 can operate at frequencies up to 38.5 MHz and is the preferred choice when spanning 38 MHz. Consult Daniels Electronics Ltd. for further information regarding operation around this frequency.

PERFORMANCE SPECIFICATIONS

The following is a general set of specifications for the generic VT-3H040 transmitter. Additional specifications, specific to individual modules may be found in their respective submanuals.

| | |
|--|---|
| Type: | MT-3 Series Transmitter |
| Family: | VT-3H040 |
| Compatibility: | MT-2 Series and MT-3 Series Radio Systems |
| Frequency Range: | <ul style="list-style-type: none"> • 29.0 MHz to 38.0 MHz • 38.0 MHz to 50.0 MHz |
| RF Power Output: | 0.5 to 3.0 W (± 1.5 dB with temperature and supply voltage) |
| System Impedance: | 50 Ω ; Type N connector |
| Duty Cycle: | 100%: Continuous operation from -30°C to +60°C (optional -40°C to +60°C) |
| Harmonic Emissions: | More than 90 dB below carrier |
| Spurious Emissions: | More than 80 dB below carrier |
| Transmitter Mismatch Protection: | 20:1 VSWR at all phase angles |
| Transmitter Alarm: | Forward power sense and reverse VSWR <ul style="list-style-type: none"> • open collector output (separate or 'OR'ed) • linear output (separate lines only) |
| Modulation: | 16K0F3E |
| Synthesizer Reference Frequency: | 9.600000 MHz or 10.000000 MHz; selectable. |
| Channel Spacing: | 20 / 25 kHz |
| Frequency Stability: | Standard: ± 1 ppm, -30°C to +60°C; optional -40°C to +60°C Provision for external 10.0 MHz reference input. |
| Channel Selection: | In 5 kHz or 6.25 kHz increments selected through four internal BCD rotary switches. Preset capability for 16 channel memory selectable through external control. |
| Standby Current and rise time: | 95% RF power, 95% system deviation within; |
| (Also see Transmitter Main Board Instruction Manual) | <ul style="list-style-type: none"> • 10 ms: typical 185 mA (Mode 4); • 25 ms: typical 160 mA (Mode 2) • 50 ms: typical 15 mA (Mode 1) • Mode 3 not used in Synthesized Transmitters |
| DOC Type Approval | RSS119 TBA, RSS122 TBA |
| FCC Type Acceptance: | H4J-VT-3H040-S |
| Operating Temperature Range: | -30°C to +60°C, optional -40°C temperature test |
| Operating Humidity: | 95% RH (non-condensing) at +25°C |
| Operating Voltage: | +13.8 VDC Nominal (range +11 to +16 VDC) +9.5 VDC Regulated. |
| Total Transmit Current: | 0.8 A typical; 1.2 A maximum |
| Front Panel Controls: | NORM (repeat mode), OFF, and KEY TX (Tx on) |
| PTT Activation: | <ul style="list-style-type: none"> • Active to ground with or without time-out timer • Microphone activated with or without time-out timer • Front Panel switch: KEY TX - without time-out timer; NORM - with or without time-out-timer; Isolated (optional relay) with or without time-out timer. |
| PTT Time Out Timer: | Selectable from 1 sec. to 8 hrs. (factory set 5 min). |

AUDIO SPECIFICATIONS

| | |
|-----------------------------------|---|
| Audio Input: | Balanced 600 ohm or unbalanced (optional) Input level sensitivity, -25 dBm to 0 dBm |
| Audio Response: | Pre-emphasis (6 dB per octave) +1.0 to -2.0 dB from 300 Hz to 3 kHz |
| Flat Audio Response: | +1 to -1 dB from 100 Hz to 3 kHz |
| Audio Deviation: | Preset to ± 3.0 kHz with a 1 kHz tone |
| Subtone Audio Input 1: | 0.5 Vpp at 200 Hz for ± 500 Hz deviation (internally adjustable) |
| Subtone Audio Input 1 Freq range: | 60 Hz to 300 Hz |
| Subtone Audio Input 2: | 0.5 Vpp at 100 Hz for ± 500 Hz deviation (internally adjustable) |
| Subtone Audio Input 2 Freq range: | DC to 150 Hz |
| Direct Modulation Input: | 0.5 Vrms at 1 kHz or ± 3 kHz deviation |
| Direct Modulation Freq range: | DC to 5 kHz |
| Audio Distortion: | Less than 2.5% THD; 1 kHz tone at 1.5 kHz or 3 kHz deviation (-40°C to +60°C) |
| Hum and Noise: | Better than 55 dB (test receiver band limited: 400 Hz to 30 kHz). |

PHYSICAL SPECIFICATIONS

| | | | |
|-----------------------|--|------------------------------|--------------------------|
| Physical Dimensions: | Width: 7.1 cm (2.8 in) | Height: 12.8 cm (5.05 in) | Depth: 19 cm (7.5 in) |
| Module Weight: | 1.5 kg (3.3 lbs) | | |
| Corrosion Prevention: | Anodized aluminum construction. Stainless steel hardware. Selectively conformal coated glass epoxy 2 and 4 layer printed circuitboards. Gold plated module connectors. | | |
| Module Design: | Compact Eurostandard modular design. Plug-in modules mate with Daniels standard M3 repeater subrack. Subracks / modules comply with IEEE 1101, DIN 41494 and IEC 297-3 (mechanical size / modular arrangement). | | |
| External Connections: | RF Connection: type N connector located on the transmitter module front panel. Motherboard Connections (Audio, Power, and Control) are made through a 48 pin, gold plated, type F connector on the rear of the transmitter module. User connection made through mated "mother board" assembly of the repeater subrack. Type F standard connector complies with DIN 41612 Level 2 (200 mating cycles, 4 day 10 ppm SO ₂ gas test with no functional impairment and no change in contact resistance). | | |
| Handle Text Colour: | Orange | | |



SYSTEM OVERVIEW

TRANSMITTER OPERATION

Several modules are integrated by the VT-3H040 Transmitter Main board to provide the complete transmitter. The Transmitter Main Board, Front Panel Board and Audio Processor are generic in that they apply to both transmitter models. The Front Panel Board and Audio Processor are soldered directly to the Transmitter Main Board and are treated collectively in the Transmitter Main Board Manual. The operating frequency range is determined by the choice of Amplifier and Frequency Synthesizer, both of which plug in to the Transmitter Main Board and can be changed with minimal effort. Circuitry and jumpers on the Transmitter Main Board control the operation of all modules and the operation of the transmitter, overall. Technical details and a complete description of transmitter operation can be found in the Transmitter Main Board Manual.

The VT-3H040 transmitter requires two power supplies; a regulated +9.5 VDC supply and a +13.8 VDC supply, the latter of which is connected only to the Amplifier Module. The (nominally) +13.8 VDC supply's range is +11 VDC to +16 VDC. The current drawn from the +13.8 VDC supply (while transmitting at the rated power) varies between 450 mA to 1000 mA with temperature, operating frequency and power supply voltage. The current drawn by the 13.8 VDC line should not exceed 1100 mA. The +9.5 VDC current drawn by the transmitter during the inactive (PTT off) state depends on what modules are enabled.

This aspect of transmitter operation is controlled by jumper settings on the Transmitter Main Board (refer to the Transmitter Main Board Manual). The minimum +9.5 VDC quiescent current is typically 15 mA and occurs when the Synthesizer and Audio Processor are disabled while the transmitter is off (Mode 1). If Synthesizer and Audio Processor operation is maintained continuously (Mode 4), the +9.5 VDC quiescent current is approximately 185 mA. Maintaining continuous operation of some modules dramatically decreases the turn on time of the transmitter.

The front panel has a DPDT toggle switch (mounted on the Front Panel Board; see the Transmitter Main Board Manual) which controls the operation of the VT-3H040 Transmitter. When in the 'OFF' position, the transmitter is turned off; however, the +13.8 VDC remains on the Transmitter Main Board terminals and on the Amplifier Module. When in the 'KEYED' position, +9.5 VDC is supplied to the transmitter circuitry and the transmitter is continuously transmitting. When this switch is in the 'NORM' position, +9.5 VDC is supplied to the transmitter circuitry although the transmitter does not transmit until keyed from one of several Push-To-Talk (PTT) inputs. The red indicator LED is illuminated during transmit.

Microphone, RF output and optional reference input are mounted on the front panel; power and other signal connections are provided by a type 'F' connector at the rear of Transmitter Main Board. Details on their function can be found in the Transmitter Main Board Manual.

FREQUENCY SELECTION

The operating frequency is determined by the synthesizer channel number selected. The relation between channel number and operating frequency is, in general, specific to the family and model of transmitter. In the case of both the VT-3H035 and VT-3H045 transmitter models, each channel corresponds to either a 5 kHz or 6.25 kHz increment in frequency, depending on whether the channel number is below 5000 or above 4999 respectively; beginning at a base frequency of 29.0 MHz. Refer to the following equations or the Channel Designation Table (IM20-VT3H040CT) for simplified channel number and frequency information.

BCD switch settings from 0000 to 4999

Subtract the base frequency from the Transmitter frequency, then divide the result by channel increment.

Example:

Base frequency = 29.0 MHz.

Transmitter frequency = 46.025 MHz.

$$((46.025 \text{ MHz} - 29 \text{ MHz}) / 5 \text{ kHz}) = 3405$$

The channel number = 3405

To determine the frequency for channel number 3405:

$$(3405 \times 5 \text{ kHz}) + 29 \text{ MHz} = 46.025 \text{ MHz}$$

BCD switch settings from 5000 to 9999

Subtract the base frequency from the Transmitter frequency, then divide the result by channel increment and add 5000.

Example:

Base frequency = 29.0 MHz.

Transmitter frequency = 48.575 MHz.

$$((48.575 \text{ MHz} - 29 \text{ MHz}) / 6.25 \text{ kHz}) + 5000 = 8132$$

The channel number = 8132.

To determine the frequency for channel number 8132:

$$((8132 - 5000) \times 6.25 \text{ kHz}) + 29 \text{ MHz} = 48.575 \text{ MHz}$$

A channel can be selected from a set of 15 (maximum possible) factory programmed channels by the four channel select lines available at the rear 'F' connector on the Transmitter Main Board. A single user selectable channel is set by switches located on the Transmitter Main Board. Refer to the Transmitter Main Board Manual for details.

TRANSMITTER ASSEMBLY AND ADJUSTMENT

All modules are mounted on the Transmitter Main Board which then forms a single assembly. An enclosure is formed by an extruded aluminum shell that slides over the Transmitter Main Board. This shell also serves as a heatsink to remove heat from the Amplifier module and for this reason, it is important that the four screws that bond the shell to the amplifier module be installed before prolonged operation of the transmitter. Moreover, the surface of the Amplifier module that contacts the shell should be clean and free of foreign material. The enclosure is completed by the installation of front and rear plates which are fastened to the Transmitter Main Board (refer to the Transmitter Main Board Manual for parts lists).

Transmitter alignment is performed on a module by module basis and detailed steps are provided in the respective manuals. Alignment is simplified by using an SR-3 Sub rack, SM-3 System Monitor, and RF extender cable to provide transmitter power and signal interconnection. Alternatively, +9.5 VDC and +13.8 VDC, as well as any required test signals, may be applied directly to the individual modules. Refer to the corresponding manuals for details.

Complete Transmitter Alignment

A complete Transmitter Alignment is performed at the factory and should not be required under normal circumstances. A large change in operating frequency, as discussed in the next section, may require a complete realignment operation. This operation requires that all the transmitter modules be aligned on a per module basis in the following order.

| Step | Module | Manual Reference |
|------|------------------------|--|
| 1) | Transmitter Main Board | Frequency selection section of this manual or the Transmitter Main Board Manual. |
| 2) | Synthesizer | Synthesizer Manual |
| 3) | Amplifier | Amplifier Manual |
| 4) | Audio Processor | Transmitter Main Board Manual |

Frequency Change

The transmitter is initially aligned at the factory for the frequency stamped on the 'Factory Set Operating Frequency' label. This label should list the frequency at which the last complete transmitter alignment was performed. For a small frequency change, a simple channel change may be all that is required. A larger frequency change may involve the realignment of other modules. The frequency change in question is the accumulated frequency change in relation to the frequency stamped on the label. For example, if the frequency is changed by 0.5 MHz from that stamped on the label, then a second frequency change of 1 MHz in the same direction would result in a total change of 1.5 MHz. The action taken would be on the basis of the 1.5 MHz value. Failure to perform a realignment after a large frequency change could result in unreliable transmitter operation or transmitter operation that does not conform to the published specifications. The allowable frequency change is summarized below.

Note: It is advisable to confirm these frequency ranges with the individual module manuals, notably the amplifier and synthesizer, as they are subject to change with updated versions. The values in the module manuals take precedent over those tabulated.

| Size of Frequency Change | Modules to be Aligned |
|-------------------------------------|---|
| less than ± 0.2 MHz | <ul style="list-style-type: none"> • Transmitter Main Board (Channel Change) |
| between ± 0.2 and ± 0.5 MHz | <ul style="list-style-type: none"> • Transmitter Main Board (Channel Change), • Audio Processor |
| between ± 0.5 and ± 1.0 MHz | <ul style="list-style-type: none"> • Transmitter Main Board (Channel Change), • Audio Processor • Synthesizer (VT-3H035 only) • * Check RF Alarm Thresholds |
| ± 1.0 MHz or greater | Complete alignment |

* May not be applicable to all installations.

Output Power Adjustment

The RF power output of the amplifier is set to its rated value of 3.0 Watts at the factory. This should not require adjustment under normal circumstances. However, should it be necessary to correct the output power, the 'Output Power Adjustment' which is described in the Amplifier Manual can be adjusted accordingly. If the Synthesizer module is replaced, it is strongly recommended that the amplifier undergo a realignment as described in the Amplifier Module, unless it is confirmed that the original and replacement synthesizer have identical output power (within ± 0.5 dBm).

Deviation Setting

The transmitter maximum deviation range is set by jumpers at the factory to ± 5.0 kHz for the VT-3H040 transmitter. However, under some conditions such as a large change in transmitter operating frequency, the deviation control may need adjustment. The transmitter deviation is dependent on the operating frequency and this dependency is likely to be more severe at the band edges. For frequency changes exceeding ± 0.5 MHz, especially at the band edges, the deviation should at least be checked and corrected if necessary. Refer to the Audio Processor section of the Transmitter Main Board Manual for details on setting the transmitter deviation.

Note: The adjustment of the balance compression levels, which is also discussed in the Audio Processor alignment section, is not required as this adjustment should not be affected by a change in frequency or deviation settings.

Setting RF Alarm Thresholds

The VSWR and Forward Power Alarms are factory preset to give alarm conditions for a 3:1 VSWR and 50% forward power respectively. The Amplifier Manual describes how to adjust these settings, should different levels be required. If the alarm thresholds are critical to operation of a particular installation and if the transmitter undergoes a large change in frequency, the threshold alarm levels, particularly

the VSWR alarm, should be checked.

RECOMMENDED TEST EQUIPMENT LIST

Alignment of the transmitter requires the following test equipment or its equivalent.

| |
|---|
| Dual Power Supply: Regulated +9.5 VDC at 2 A. |
| Regulated +13.8 VDC at 2 A: Topward TPS-4000 |
| Oscilloscope / Multimeter: Fluke 97 Scopemeter |
| Current Meter: Fluke 75 multimeter |
| Radio communications test set : Marconi Instruments 2955R |
| VSWR 3:1 mismatch load: JFW 50T-035-3.0:1 |
| Alignment Tool: Johanson 4192 |

It is recommended that the radio communications test set be frequency locked to an external reference (WWVH, GPS, Loran C) so that the high stability oscillator may be accurately set to within its ± 1 ppm frequency tolerance.

REPAIR NOTE

The transmitter is mainly made up of surface mount devices which should not be removed or replaced using an ordinary soldering iron. Removal and replacement of surface mount components should be performed only with specifically designed surface mount rework and repair stations complete with Electrostatic Discharge (ESD) protection.

When removing Surface Mount Solder Jumpers, it is recommended to use solder braid in place of manual vacuum type desoldering tools when removing jumpers. This will help prevent damage to the circuit boards.



ILLUSTRATIONS AND SCHEMATICS

PRINTED CIRCUIT BOARD NUMBERING CONVENTION

Daniels Electronics Ltd. has adopted a printed circuit board (PCB) numbering convention in which the last two digits of the circuit board number represent the circuit board version. All PCB's manufactured by Daniels Electronics Ltd. are identified by one of the following numbering conventions:

| | |
|------------|---|
| PCB number | 43-9120 <u>10</u> Indicates circuit board version 1.0 |
| PCB number | 50002- <u>02</u> Indicates circuit board version 2 (no decimal version) |

VHF ENHANCED TRANSMITTER FRONT PANEL

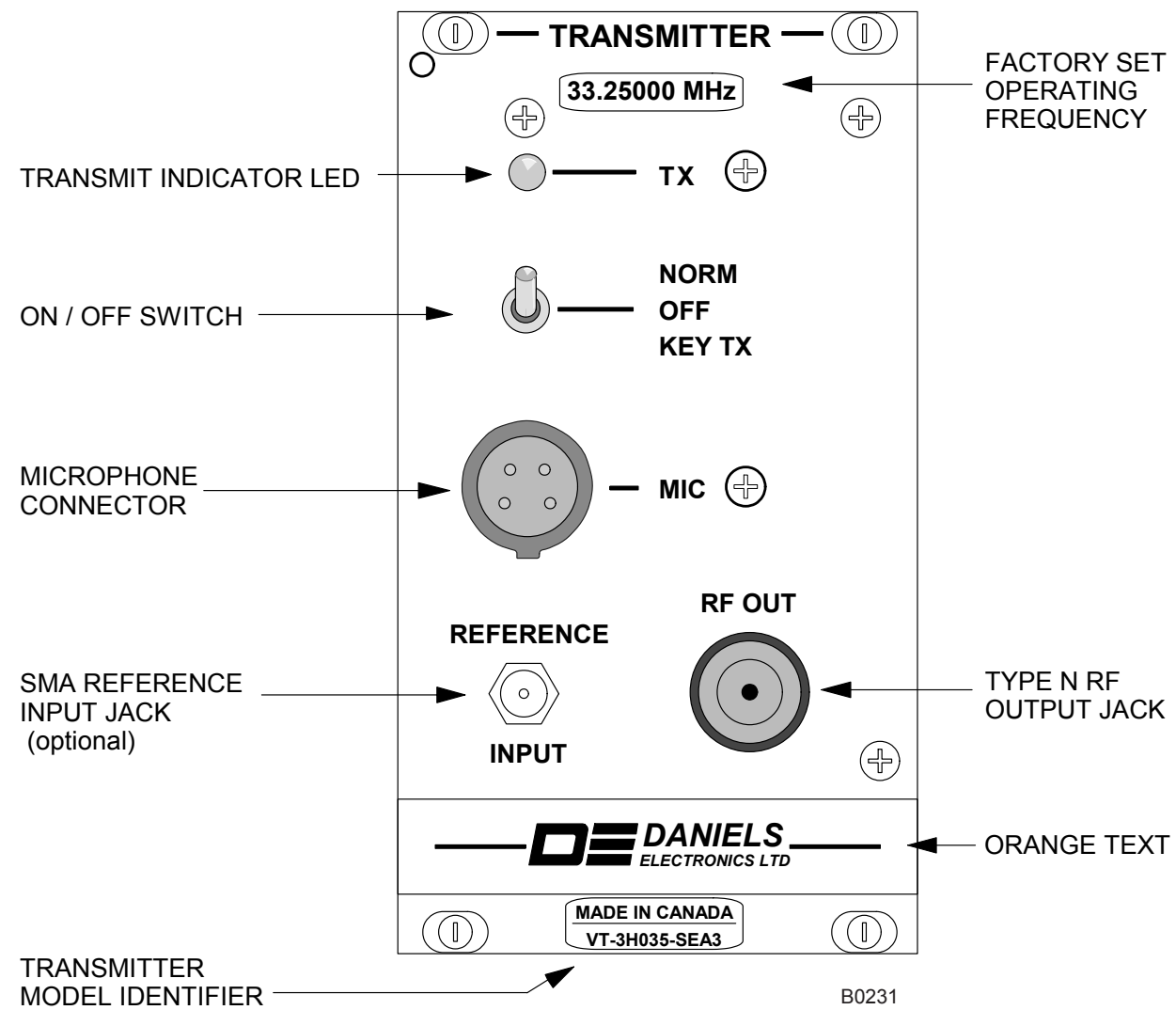

VHF ENHANCED TRANSMITTER CASE REMOVAL

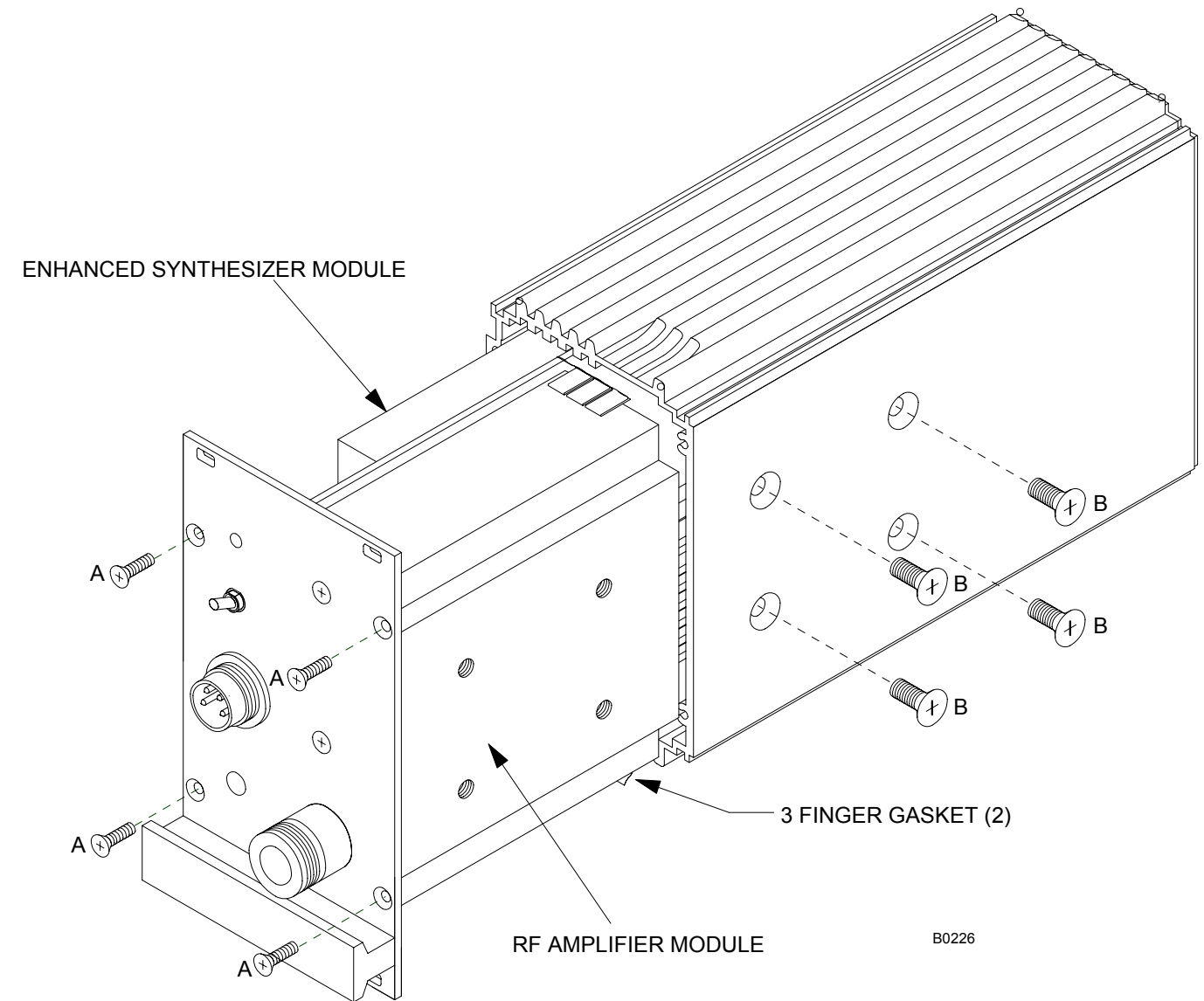

Instructions

1. Remove the four screws (A) in the Front panel.
2. Remove the four screws (B) on the side of the Transmitter Case.

VHF ENHANCED TRANSMITTER BLOCK DIAGRAM

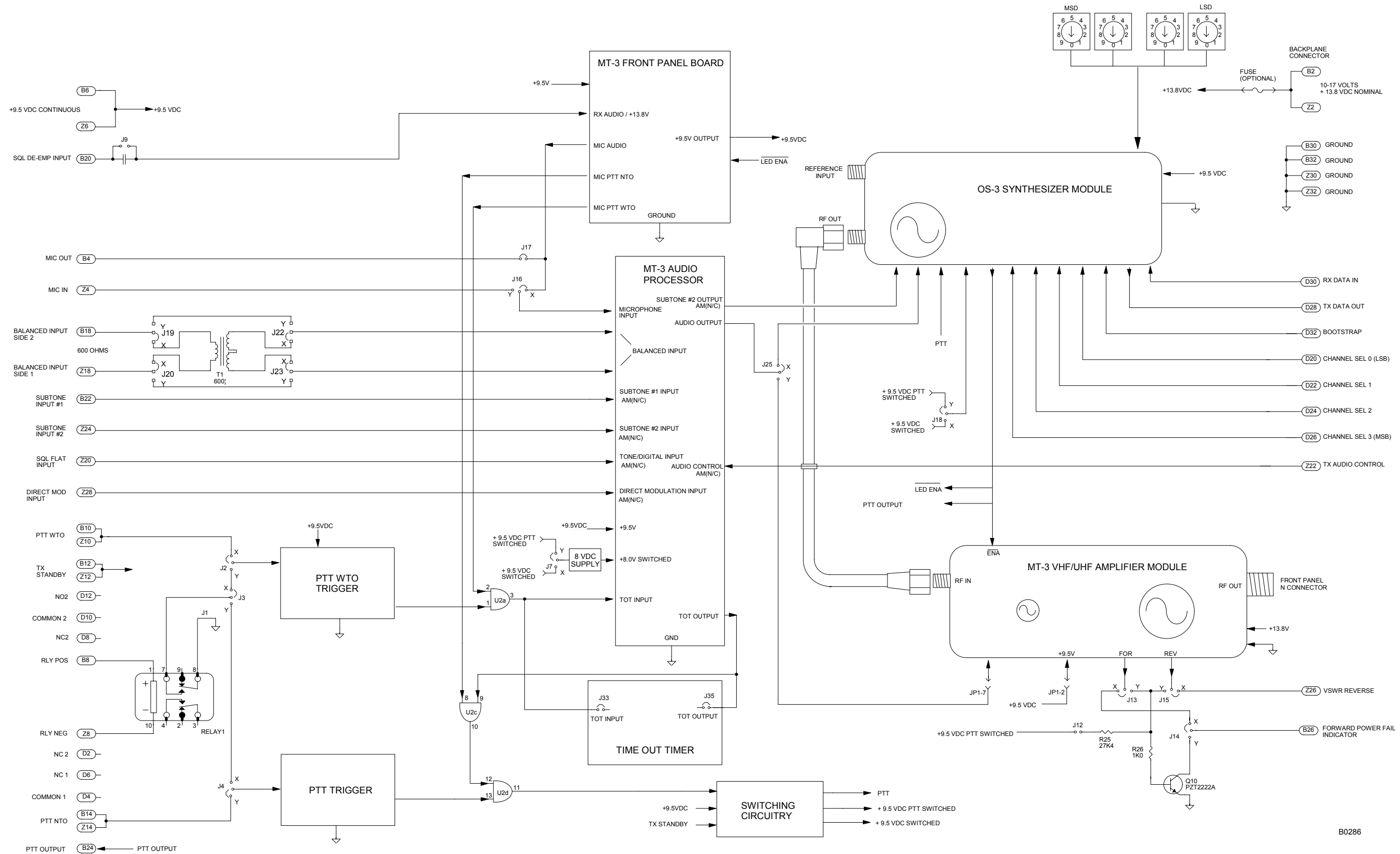

B0286



PARTS LISTS

MECHANICAL PARTS LIST

| Description | Part Number | Qty |
|---------------------------------|---------------|-----|
| CASE, 14HP RF PLUG-IN, MT-3 TX | 3702-62502010 | 1 |
| CONNECTOR, MIC., 4 PIN, MALE | 5040-114ST0BK | 1 |
| FASTENER, QUICK RELEASE, GRAY | 3702-10000120 | 4 |
| GASKET, BeCu,3FINGER,.71",CLIP | 5630-12023250 | 2 |
| HANDLE, FRONT PANEL, 14HP,GREY | 3702-10000614 | 1 |
| HOLE PLUG, .250" HOLE,NYL.,BLK | 5671-250N062B | 1 |
| LABEL SET, FOIL,RF MODULE INFO | 3501-27101000 | 1 |
| LABEL/LEXAN, 14HP, VHF: ORANGE | 3536-10101405 | 1 |
| LOCKWASHER, M3, SPLIT,A2 STEEL | 5814-3M0LK00S | 4 |
| NAMEPLATE, BLANK, 14HP, ALUM. | 3702-10001214 | 1 |
| NUT, M2.5, SQUARE-5mm, ZINC | 5813-2M5SQ50Z | 2 |
| PANEL, REAR,POS.4,14HP EXTRSN. | 3702-63002101 | 1 |
| PANEL/FRNT,W/IDENT:TX-EXTR.VER | 3802-61002101 | 1 |
| SCREW, M2.5 x 14 FLAT/PHIL, A2 | 5812-2M5FP14S | 2 |
| SCREW, M3 X 6, PAN/PHILLIPS,A2 | 5812-3M0PP06S | 4 |
| SCREW, M3 x 6, OVAL C/S/PHIL,A2 | 5812-3M0VP06S | 2 |
| SCREW, M3 x 8, PAN/PHIL, BLACK | 5812-3M0PP08T | 4 |
| SCREW, M3 x 8, OVAL C/S/PHIL,A2 | 5812-3M0VP08S | 2 |
| SCREW, M3 x10, OVAL C/S/PHIL,A2 | 5812-3M0VP10S | 2 |
| SCREW, M5 x 8, FLAT/PHIL., A2 | 5812-5M0FP08S | 4 |



REVISION HISTORY

| Revision | Date | CO | Description |
|----------|---------|-----|--|
| 1 | June 97 | --- | First Issue |
| 1A | Sept 98 | --- | • Corrected part number for this manual |
| | Jan 99 | --- | • Corrected RF Power Output to read 0.5 to 3.0W instead of 3.0 W fixed |
| 1-1-0 | Feb 04 | --- | • Updated document to new format |
| 1-1-1 | Apr 07 | --- | <ul style="list-style-type: none"> • Corrected Module Manual Reference IM20-VT3H040CT, was missing the 'H'. • Minor formatting updates, © Date and ™ Statement updated. • Top level hardware added to Parts Lists, the previous list was incomplete. • B0231 Front Panel illustration updated to show new Freq. and Model ID labels. |
| 1-1-2 | July 08 | --- | • Editorial Updates |

