

ENHANCED FRONT END INSTRUCTION MANUAL

FE3H 29 - 50 MHz

Covers Models:

A10-FE3H035

A10-FE3H045

Copyright © 2004 Daniels Electronics Ltd. All rights reserved. No part of this publication may be reproduced, stored in a retrieval system or transmitted in any form or by any means, electronic, mechanical, photocopying, recording or otherwise, without the prior written consent of Daniels Electronics Ltd.

DE™ is a registered trademark of Daniels Electronic Ltd. registered in the U.S. Patent and Trademark Office.

DOCUMENT CONTROL

This document has been produced, verified and controlled in accordance with Daniels Electronics' Quality Management System requirements. Please report any errors or problems to Daniels Electronics' Customer Service Department.

NOTE

The user's authority to operate this equipment could be revoked through any changes or modifications not expressly approved by Daniels Electronics Ltd. The design of this equipment is subject to change due to continuous development. This equipment may incorporate minor changes in detail from the information contained in this manual.

Contents

General Information	1
Introduction	1
Performance Specifications	2
Theory of Operation	3
General	3
Power and Interconnection	4
Preselector Filter	4
RF Amplifier	4
Image Rejection Filter	4
Local Oscillator Filter	4
Double Balanced Mixer	4
Enhanced Front End Alignment	5
Repair Note	5
General	5
Recommended Test Equipment	6
Check Points	6
Preferred Tuning Procedure	7
Alternate Tuning Procedure	7
Enhanced Front End Removal and Installation	7
Circuit Board Removal	7
Illustrations and Schematics	9
Enhanced Front End Block Diagram	10
Enhanced Front End Tuning Diagram	10
Bandpass Filter Component Layout	11
Bandpass Filter Schematic Diagram	11
Enhanced Front End Component Layout	12
Enhanced Front End Schematic Diagram	13
Parts Lists	15
Enhanced Front End Board Electrical Parts List	15
Bandpass Filter Board Electrical Parts List	17
Mechanical Parts List	18
Revision History	19



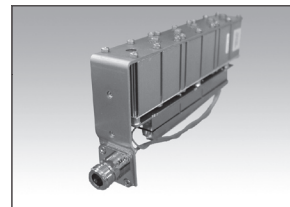

GENERAL INFORMATION

INTRODUCTION

The FE3H040 Enhanced Front End is a highly integrated, frequency selective, down converter used in Daniels Electronics standard MT-3 Low Band VHF FM receiver product line. The FE3H040 Front End connects to the 21.4 MHz IF / Audio Main Board and the enhanced Synthesizer to form a complete receiver..

PERFORMANCE SPECIFICATIONS

Frequency Range:	29.0 MHz - 38.5 MHz (FE3H035) 37.5 MHz - 50.0 MHz (FE3H045)
IF Frequency:	21.4 MHz
3 dB Bandwidth:	> 5 MHz (Preselector Filter)
Conversion Gain:	12.5 dB
Third Order Intercept Point:	> +18 dBm
Image Rejection:	> 100 dB
Impedance:	50 Ω at RF, LO, and IF ports
Temperature Range:	-30°C To +60°C (Optional -40°C To +60°C)
Power Requirements:	+9.5 Vdc @ 160 mA

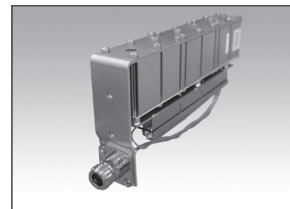

THEORY OF OPERATION

GENERAL

The Enhanced Front End amplifies and down converts the RF signal to the IF frequency of 21.4 MHz. The FE3H035 and FE3H045 Front Ends use high side injection. Power is supplied by a regulated +9.5 volts and draws typically 160 mA. The Enhanced Front End consists of the following:

-
- Five Section L-C coupled Bandpass Filter
-
- Single Stage Low Noise RF Amplifier
-
- Image Rejection Filter
-
- Local Oscillator Low Pass Filter
-
- Double Balanced Active Mixer
-

All terminations are 50 Ω impedance.

POWER AND INTERCONNECTION

The FE3H Enhanced Front End operates from +9.5 Vdc applied via a short red wire connected to supply point J6-2 on the receiver main IF/audio board. Ground return is supplied via direct mounting to the receiver chassis and coaxial cable interconnections. The FE3H Front End draws approximately 160 mA from the IF/audio board's +9.5 Vdc supply.

The RF input signal connected to the receiver front panel type N connector is fed to the Front End SMB input connector (J1) by a short coaxial cable. The FE3H Front End's local oscillator input and IF output are respectively routed by coaxial cable from the local oscillator module and to SMB connector J7 on the main IF/audio board.

PRESELECTOR FILTER

The received RF signal is filtered by a five section L-C coupled band pass filter. This filter provides front end selectivity and attenuates any potential internally generated spurious signals. The filter has an operational bandwidth of 5 MHz and a typical insertion loss of 2 dB. The filter is tunable (L1 through L5) in the following ranges :

• FE3H035	29.0 MHz - 38.5 MHz
• FE3H045	37.5 MHz - 50.0 MHz

Every Enhanced Front End has an identification label indicating one of two operating frequency bands.

RF AMPLIFIER

The output from the preselector filter is coupled through DC blocking capacitor C8 to the base of RF amplifier Q2. The RF amplifier stage is supplied by the regulated +9.5 Vdc line and typically draws 60 mA of collector current. It provides a high third order intercept point and low noise figure. Transistor Q1 actively regulates the bias to RF transistor Q2. The output signal is coupled to an image rejection filter via DC blocking capacitor C10. Typically, the RF amplifier stage has a gain of 16 dB.

IMAGE REJECTION FILTER

The amplified RF signal is followed by an image rejection filter. This filter rejects image noise after amplification. The low pass filter consists of C11 through C14, and L3 through L5. It is a low pass filter designed to pass the desired frequency range of 29.0 MHz - 50.0 MHz and reject the image band of 71.8 MHz - 92.8 MHz. Typical insertion loss is 1.5 dB.

LOCAL OSCILLATOR FILTER

The local oscillator filter is a low pass filter consisting of C34 through C37, and L10 through L12. Typical insertion loss is 1.5 dB. Input level to the local oscillator filter is typically +5 dBm. Following the filter is an attenuation network with an insertion loss of 7.5 dB.

DOUBLE BALANCED MIXER

The Double Balanced Mixer consists of active mixer M1. The received RF signal in the 29.0 MHz - 50.0 MHz range is down converted to the 21.4 MHz first conversion IF frequency by the use of high side injection. The mixer is driven by an LO signal of typically -4 dBm. Typical current draw for the mixer is 100 mA. Typical conversion loss is 0 dB.

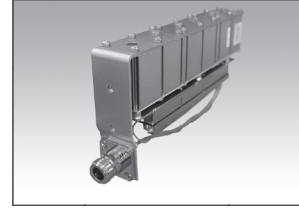

ENHANCED FRONT END ALIGNMENT

REPAIR NOTE

The Enhanced Front End module is mainly made up of surface mount devices that should not be removed or replaced using an ordinary soldering iron. Removal and replacement of surface mount components should be performed only with specifically designed surface mount rework and repair stations complete with Electrostatic Discharge (ESD) protection.

When removing Surface Mount Solder Jumpers, it is recommended to use solder braid in place of manual vacuum type desoldering tools. This will help prevent damage to the circuit boards.

GENERAL

Alignment for the FE3H040 Enhanced Front End consists of tuning the five section bandpass filter only. No tuning is required for frequency changes within the 3 dB bandwidth (5 MHz) of its originally tuned frequency. However, without tuning at the 3 dB band edges, the receivers sensitivity will be degraded. Normally, no tuning is required for small frequency changes. For Large frequency changes use the tuning procedure below.

RECOMMENDED TEST EQUIPMENT

Alignment of the Enhanced Front End requires the following test equipment or its equivalent:

• Power supply	Regulated +9.5 Vdc at 1 A. Phillips PM 2811
• Spectrum Analyzer with Tracking Generator	
• Alignment Tool	Coilcraft 37-1409

CHECK POINTS

Vsupply	+ 9.5 Vdc @ 160 mA
Bandpass Filter Loss	2 dB
RF Amplifier Gain	16 dB
Image Rejection Filter Loss	1.5 dB
First Mixer Conversion Loss	0 dB
Vb of Q1	+ 7 Vdc
Vc of Q2	+ 7.5 Vdc
Vp of M1	+ 9.3 Vdc
Local Oscillator Frequency	RF Frequency + 21.4 MHz
Local Oscillator Filter Loss	1.5 dB
Local Oscillator Attenuator Loss	7.5 dB

PREFERRED TUNING PROCEDURE

The preferred method of tuning the Enhanced Front End is to use a Spectrum Analyzer with a Tracking Generator. With the Local Oscillator absent, the frequency response of the Preselector Filter can be seen at the IF port. Use the following procedure for swept frequency tuning:

-
- Supply +9.5 Vdc to the Enhanced Front End.
-
- Connect the Tracking Generator output with -10 dBm or less to the RF input.
-
- Connect the IF output to the Spectrum Analyzer input. Center the spectrum analyzer at the desired RF frequency. Adjust L1 through L5 for a uniformly flat response at a level typically -30 dBc, centered at the desired RF frequency (Refer to Enhanced Front End Tuning Diagram).
-

ALTERNATE TUNING PROCEDURE

The alternate method of tuning the Enhanced Front End is to use a complete receiver and monitor receiver SINAD. Use the following procedure for tuning:

-
- Inject the desired RF signal to the RF IN connector at a level of -20 dBm.
-
- Inject the desired LO signal to the LO IN cable at a level of +5 dBm (LO freq.=RF+21.4 MHz).
-
- Connect the IF OUT to the IF/RF IN connector on the IF/Audio Board. Adjust L1 through L5 and tune for best receiver SINAD (> -118 dBm).
-

ENHANCED FRONT END REMOVAL AND INSTALLATION

The Enhanced Front End is fastened to the main board (MT-3 Receiver IF/Audio Board) with a single Phillips screw and fastened to the front panel with two countersunk Phillips screws. Remove these screws and disconnect the IF, LO, and power cables to remove the Enhanced Front End. Installation of the Enhanced Front End is the reverse of the above procedure.

CIRCUIT BOARD REMOVAL

Removal of the circuit boards is accomplished by removing all 18 Phillips screws and lockwashers. To separate the two circuit boards from each other, the small piece of semi-rigid coax must be desoldered. Follow a reverse procedure to re-assemble.



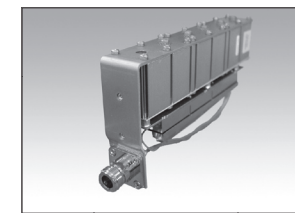

ILLUSTRATIONS AND SCHEMATICS

PRINTED CIRCUIT BOARD NUMBERING CONVENTION

Daniels Electronics Ltd. has adopted a printed circuit board (PCB) numbering convention in which the last two digits of the circuit board number represent the circuit board version. All PCB's manufactured by Daniels Electronics Ltd. are identified by one of the following numbering conventions:

PCB number	<u>43-912010</u> Indicates circuit board version 1.0
PCB number	<u>50002-02</u> Indicates circuit board version 2 (no decimal version)

ENHANCED FRONT END BLOCK DIAGRAM

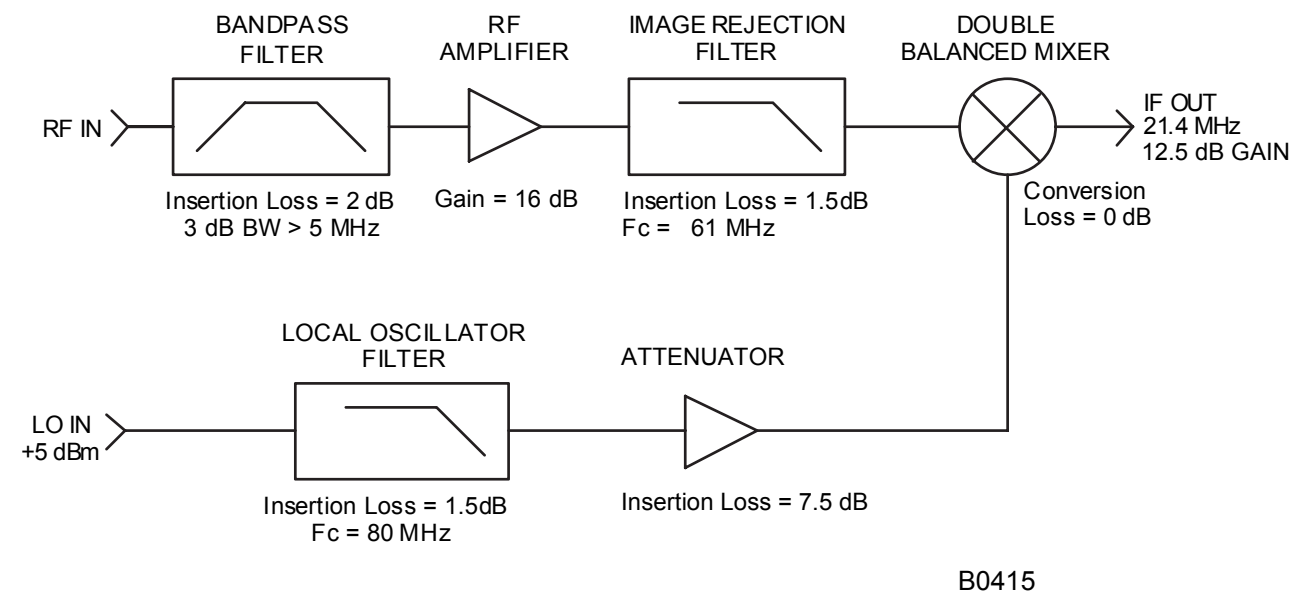

ENHANCED FRONT END TUNING DIAGRAM

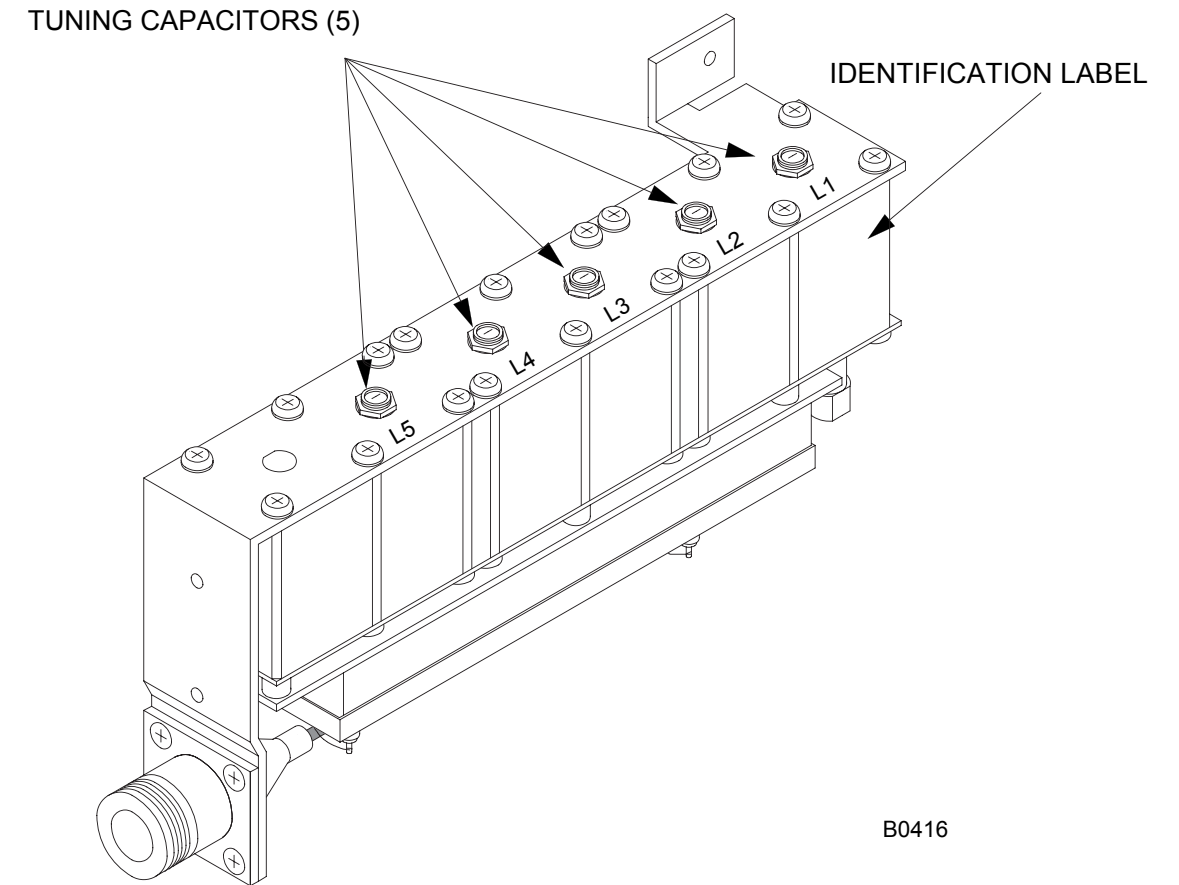

BANDPASS FILTER COMPONENT LAYOUT

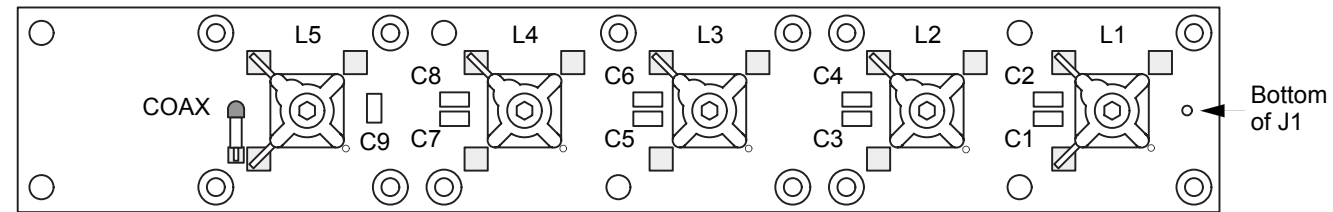

Designator	FE3H035 29.0 - 38.5 MHz	FE3H045 37.5 - 50.0 MHz
C1	82 pF	68 pF
C2	15 pF	10 pF
C3	68 pF	56 pF
C4	12 pF	8.2 pF
C5	82 pF	68 pF
C6	12 pF	8.2 pF
C7	68 pF	56 pF
C8	15 pF	10 pF
C9	82 pF	68 pF

Designator	Low Band (Blue)	High Band (Green)
L1	193-306 nH (Tapped)	162-252 nH (Tapped)
L2	193-306 nH	162-252 nH
L3	193-306 nH	162-252 nH
L4	193-306 nH	162-252 nH
L5	193-306 nH (Tapped)	162-252 nH (Tapped)

		1 2 3 4 5 6 7 8 9 10 11 12 13 14 15 16 17 18 19 20 21 22 23 24 25 26 27 28 29 30									
		TITLE: ENHANCED FRONT END BANDPASS FILTER BOARD DATE: 6 JANUARY 1997 BOARD NO: 50034-01 DWG No: 01-T-01-01 REV DATE: 6 JUNE 2003									

BANDPASS FILTER SCHEMATIC DIAGRAM

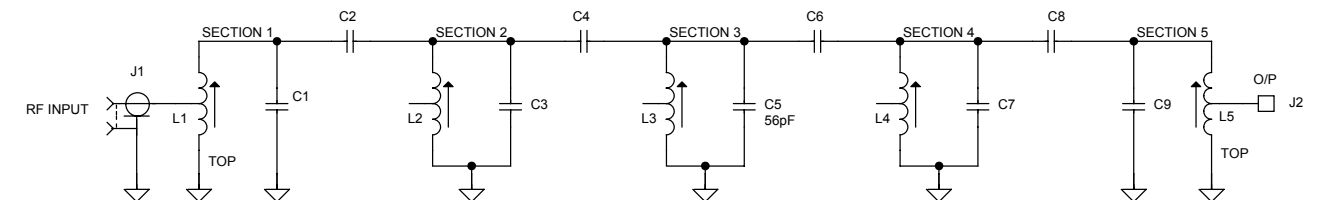

Designator	FE3H035 29-38.5 MHz	FE3H045 37.5-50 MHz
C1	82 pF	68 pF
C2	15 pF	10 pF
C3	68 pF	56 pF
C4	12 pF	8.2 pF
C5	82 pF	68 pF
C6	12 pF	8.2 pF
C7	68 pF	56 pF
C8	15 pF	10 pF
C9	82 pF	68 pF
L1	193-306 nH	162-252 nH
L2	193-306 nH	162-252 nH
L3	193-306 nH	162-252 nH
L4	193-306 nH	162-252 nH
L5	193-306 nH	162-252 nH

HIGHEST REFERENCE DESIGNATORS		
C9	L5	----
----	----	----
----	----	----



UNUSED REFERENCE DESIGNATORS		
----	----	----
----	----	----
----	----	----

		VICTORIA BC.	
		TITLE: ENHANCED FRONT END BANDPASS FILTER BOARD SCHEMATIC DIAGRAM	
DATE: 6 FEBRUARY 1997	DWN BY: ROBERT FICHTNER	APRVD:	
DWG No.: 01-S-01-01	REVISED BY: NIKKI BEREKOFF		
BOARD No.: 50034-01	REV: 01	DWG REV DATE: 9 JUNE 2003	

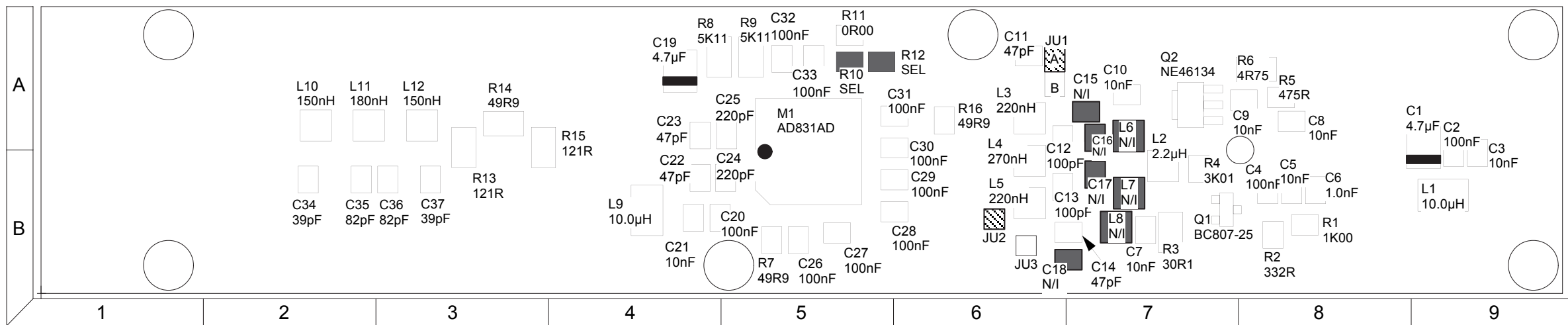
ENHANCED FRONT END COMPONENT LAYOUT



COMPONENT LOCATION TABLE							
DES	LC	DES	LC	DES	LC	DES	LC
C1	A9	C21	B4	JU3	B6	R1	B8
C2	B9	C22	B4			R2	B8
C3	B9	C23	A4	L1	B9	R3	B7
C4	B8	C24	B5	L2	B7	R4	B7
C5	B8	C25	A5	L3	A6	R5	A8
C6	B8	C26	B5	L4	B6	R6	A6
C7	B7	C27	B5	L5	B6	R7	B5
C8	A8	C28	B6	L6	A7	R8	A4
C9	A8	C29	B6	L7	B7	R9	A5
C10	A7	C30	A6	L8	B7	R10	A5
C11	A6	C31	A6	L9	B4	R11	A5
C12	A6	C32	A5	L10	A2	R12	A5
C13	B6	C33	A5	L11	A2	R13	A3
C14	B7	C34	B2	L12	A3	R14	A3
C15	A7	C35	B2			R15	A3
C16	A7	C36	B3	M1	A5	R16	A6
C17	B7	C37	B3				
C18	B7			Q1	B7		
C19	A4	JU1	A6	Q2	A7		
C20	B4	JU2	B6				

 - INSTALL JUMPERS
 - NOT INSTALLED

		<table border="1"> <tr> <td>A</td><td>A</td><td>A</td><td>A</td><td>A</td><td>A</td><td>A</td><td>A</td><td>A</td><td>A</td><td>A</td> </tr> <tr> <td>11</td><td>12</td><td>13</td><td>14</td><td>15</td><td>16</td><td>17</td><td>18</td><td>19</td><td>20</td><td></td> </tr> <tr> <td>21</td><td>22</td><td>23</td><td>24</td><td>25</td><td>26</td><td>27</td><td>28</td><td>29</td><td>30</td><td></td> </tr> </table>										A	A	A	A	A	A	A	A	A	A	A	11	12	13	14	15	16	17	18	19	20		21	22	23	24	25	26	27	28	29	30	
		A	A	A	A	A	A	A	A	A	A	A																																
11	12	13	14	15	16	17	18	19	20																																			
21	22	23	24	25	26	27	28	29	30																																			
TITLE: VR-3H040 ENHANCED FRONT END BOARD TOP DATE: 25 MARCH 1997 BOARD NO: 50041-01 DWG No: 01-T-01-01 REV DATE: 5 APRIL 2004																																												

ENHANCED FRONT END SCHEMATIC DIAGRAM

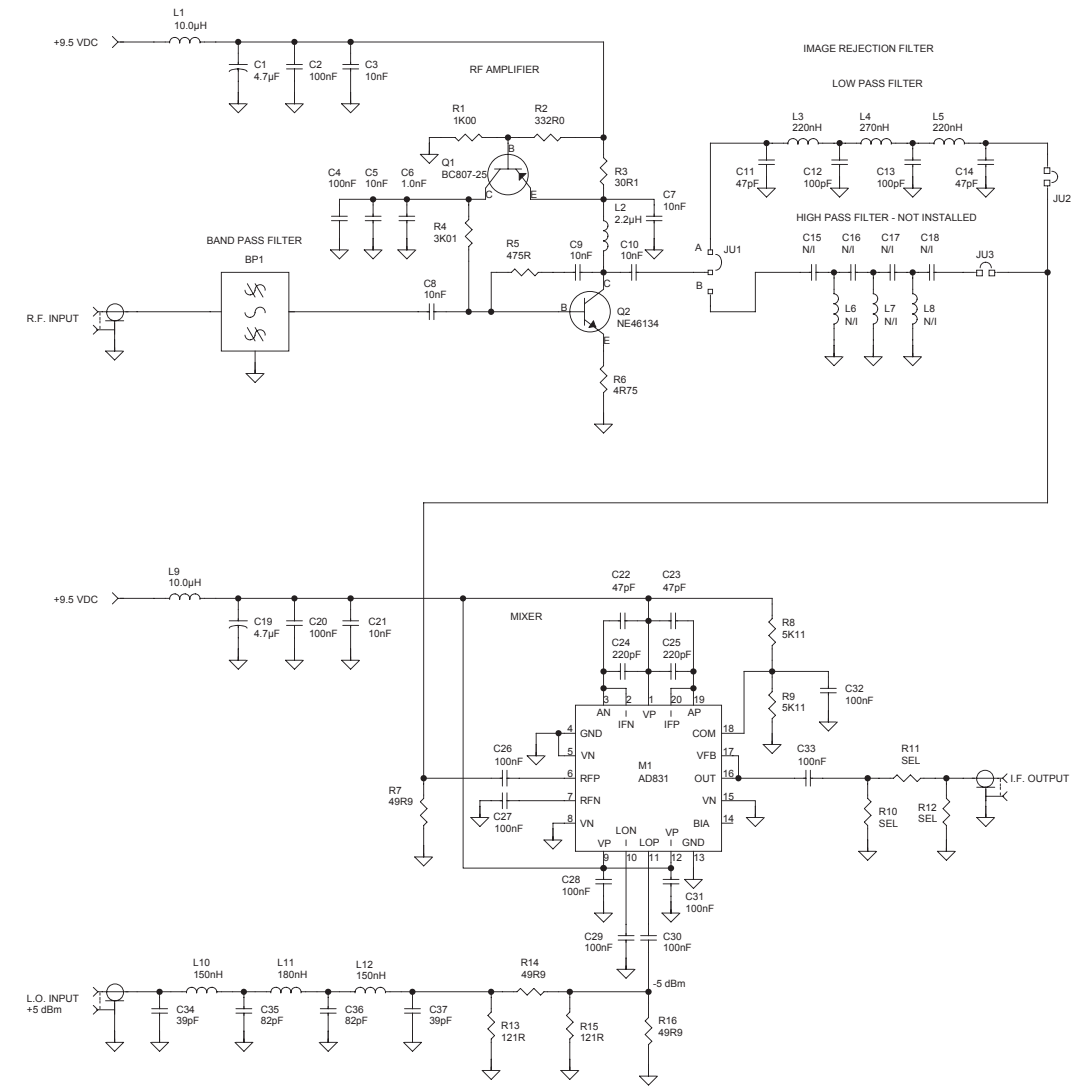

COMPONENT LOCATION TABLE

DES	LC	DES	LC	DES	LC	DES	LC	DES	LC
BP1	C4	G3	C29	E3	B1	E4	L12	C8	Q1
	C15	F4	C30	E8	JU2	G3	M1	Q2	R13
C1	C2	F4	C31	E7	JU3	G4	M1	E8	R14
C2	C2	F4	C32	E8	JU3	G4	M1	R1	R15
C3	C2	F4	C33	F7	L1	B2	Q1	D3	R2
C4	C3	F4	C34	B8	L2	E3	Q2	E4	R3
C5	C3	F4	C35	D8	L3	F3	R4	D3	R4
C6	D3	C21	C36	D8	L4	F3	L19	F3	R5
C7	E3	C22	E8	C37	D8	L5	G3	L20	G3
C8	B4	C23	E8	L6	F4	L21	G3	R7	D7
C9	E4	C24	E8	J1	B4	L7	F4	L22	B3
C10	E4	C25	E8	J2	G7	L8	G4	L23	B3
C11	F3	C26	D7	J3	B8	L9	B6	L24	C3
C12	F3	C27	D7	J4	B8	L10	B6	L25	C3
C13	G3	C28	E7	J5	B2	L11	C8	L26	C3

HIGHEST REFERENCE DESIGNATORS

C37	JU3	L12
M1	Q2	R16
---	---	---

UNUSED REFERENCE DESIGNATORS

---	---	---
---	---	---
---	---	---

DE DANIELS
ELECTRONICS LTD. VICTORIA BC.

TITLE: VR-3H040 ENHANCED FRONT END BOARD SCHEMATIC DIAGRAM

DATE: 19 MARCH 1997 DWN BY: BRAD KOSSIANCE APRVD:

DWG No.: 01-S-01-01 REVISED BY: NIKKI B

BOARD No.: 50041-01 REV: 01 DWG REV DATE: 6 APRIL 2004

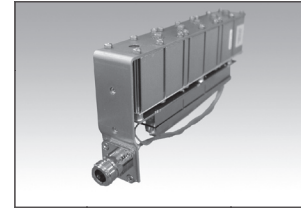

PARTS LISTS

ENHANCED FRONT END BOARD ELECTRICAL PARTS LIST

Ref		
Desig	Description	Part Number
C1	CAP., SM, 4.7uF TANT., 10%, 16V	1055-5B475K16
C2	CAP., SM, 100nF CER,0805,X7R,50	1008-5A104K5R
C3	CAP., SM, 10nF CER,0805,X7R,50V	1008-4A103K5R
C4	CAP., SM, 100nF CER,0805,X7R,50	1008-5A104K5R
C5	CAP., SM, 10nF CER,0805,X7R,50V	1008-4A103K5R
C6	CAP., SM, 1nF CER,0805,X7R,50V	1008-3A102K5R
C7	CAP., SM, 10nF CER,0805,X7R,50V	1008-4A103K5R
C8	CAP., SM, 10nF CER,0805,X7R,50V	1008-4A103K5R
C9	CAP., SM, 10nF CER,0805,X7R,50V	1008-4A103K5R
C10	CAP., SM, 10nF CER,0805,X7R,50V	1008-4A103K5R
C11	CAP., SM, 47pF CER., 0805, C0G	1008-1A470J1G
C12	CAP., SM, 100pF CER., 0805, C0G	1008-2A101J1G
C13	CAP., SM, 100pF CER., 0805, C0G	1008-2A101J1G
C14	CAP., SM, 47pF CER., 0805, C0G	1008-1A470J1G
C19	CAP., SM, 4.7uF TANT., 10%, 16V	1055-5B475K16
C20	CAP., SM, 100nF CER,0805,X7R,50	1008-5A104K5R
C21	CAP., SM, 10nF CER,0805,X7R,50V	1008-4A103K5R
C22	CAP., SM, 47pF CER., 0805, C0G	1008-1A470J1G
C23	CAP., SM, 47pF CER., 0805, C0G	1008-1A470J1G
C24	CAP., SM, 220pF CER., 0805, C0G	1008-2A221J1G
C25	CAP., SM, 220pF CER., 0805, C0G	1008-2A221J1G
C26	CAP., SM, 100nF CER,0805,X7R,50	1008-5A104K5R
C27	CAP., SM, 100nF CER,0805,X7R,50	1008-5A104K5R
C29	CAP., SM, 100nF CER,0805,X7R,50	1008-5A104K5R
C30	CAP., SM, 100nF CER,0805,X7R,50	1008-5A104K5R
C31	CAP., SM, 100nF CER,0805,X7R,50	1008-5A104K5R
C32	CAP., SM, 100nF CER,0805,X7R,50	1008-5A104K5R
C33	CAP., SM, 100nF CER,0805,X7R,50	1008-5A104K5R
C34	CAP., SM, 39pF CER., 0805, C0G	1008-1A390J1G
C35	CAP., SM, 82pF CER., 0805, C0G	1008-1A820J1G
C36	CAP., SM, 82pF CER., 0805, C0G	1008-1A820J1G
C37	CAP., SM, 39pF CER., 0805, C0G	1008-1A390J1G
L1	INDUCTOR, SM, 10.0uH, 10%, 1812	1255-4G10000K
L2	INDUCTOR, SM, 2.2uH CER, 10%, 1008	1256-3B2R200K
L3	INDUCTOR, SM, 220nH CER, 10%, 1008	1256-2BR2200K
L4	INDUCTOR, SM, 270nH CER, 10%, 1008	1256-2BR2700K

Enhanced Front End Board Electrical Parts List cont'd

Ref Desig	Description	Part Number
L5	INDUCTOR,SM,220nH CER,10%,1008	1256-2BR2200K
L9	INDUCTOR, SM, 10.0uH, 10%,1812	1255-4G10000K
L10	INDUCTOR,SM,150nH CER,10%,1008	1256-2BR1500K
L11	INDUCTOR,SM,180nH CER,10%,1008	1256-2BR1800K
L12	INDUCTOR,SM,150nH CER,10%,1008	1256-2BR1500K
M1	IC, AD831AP, MIXER-L/D, PLCC20	2360-83100P20
PCB	PCB, FRONT END AMP/MIX.,LB VHF	4310-72500411
Q1	TRANSISTOR, BC807-25,PNP,SOT23	2120-BC807025
Q2	TRANSISTOR, NE46134, RF,SOT-89	2127-NE461340
R1	RES., SM, 1K00 0805, 1%,100ppm	1150-3A1001FP
R2	RES., SM, 332R 0805, 1%,100ppm	1150-2A3320FP
R3	RES., SM, 30R1 1206, 1%,100ppm	1150-1B30R1FP
R4	RES., SM, 3K01 0805, 1%,100ppm	1150-3A3011FP
R5	RES., SM, 475R 0805, 1%,100ppm	1150-2A4750FP
R6	RES., SM, 4R75 1206, 1%,400ppm	1150-0B4R75FG
R7	RES., SM, 49R9 0805, 1%,100ppm	1150-1A49R9FP
R8	RES., SM, 5K11 1206, 1%,100ppm	1150-3B5111FP
R9	RES., SM, 5K11 1206, 1%,100ppm	1150-3B5111FP
R11	RES., SM, ZERO OHM JUMPER,0805	1150-0A0R0000
R13	RES., SM, 121R 1206, 1%,100ppm	1150-2B1210FP
R14	RES., SM, 49R9 1206, 1%,100ppm	1150-1B49R9FP
R15	RES., SM, 121R 1206, 1%,100ppm	1150-2B1210FP
R16	RES., SM, 49R9 0805, 1%,100ppm	1150-1A49R9FP

BANDPASS FILTER BOARD ELECTRICAL PARTS LIST

Ref Desig	Description	Part Number	A10-FE3H035	A10-FE3H045
C1	CAP., SM, 68pF CER., 0805, COG	1008-1A680J1G		•
	CAP., SM, 82pF CER., 0805, COG	1008-1A820J1G	•	
C2	CAP., SM, 10pF CER., 0805, COG	1008-1A100J1G		•
	CAP., SM, 15pF CER., 0805, COG	1008-1A150J1G	•	
C3	CAP., SM, 56pF CER., 0805, COG	1008-1A560J1G		•
	CAP., SM, 68pF CER., 0805, COG	1008-1A680J1G	•	
C4	CAP., SM, 12pF CER., 0805, COG	1008-1A120J1G	•	
	CAP., SM, 8.2pF CER., 0805, COG	1008-0A829J1G		•
C5	CAP., SM, 68pF CER., 0805, COG	1008-1A680J1G		•
	CAP., SM, 82pF CER., 0805, COG	1008-1A820J1G	•	
C6	CAP., SM, 12pF CER., 0805, COG	1008-1A120J1G	•	
	CAP., SM, 8.2pF CER., 0805, COG	1008-0A829J1G		•
C7	CAP., SM, 56pF CER., 0805, COG	1008-1A560J1G		•
	CAP., SM, 68pF CER., 0805, COG	1008-1A680J1G	•	
C8	CAP., SM, 10pF CER., 0805, COG	1008-1A100J1G		•
	CAP., SM, 15pF CER., 0805, COG	1008-1A150J1G	•	
C9	CAP., SM, 68pF CER., 0805, COG	1008-1A680J1G		•
	CAP., SM, 82pF CER., 0805, COG	1008-1A820J1G	•	
L1	INDUCT/VAR., 162-252uH, TAP3+3/8	1263-10C05U27		•
	INDUCT/VAR., 193-306uH, TAP4+3/8	1263-10C06U35	•	
L2	INDUCTOR/VAR., 162-252nH, UNSHLD	1262-110C207U	•	
	INDUCTOR/VAR., 193-306nH, UNSHLD	1262-110C250U		•
L3	INDUCTOR/VAR., 162-252nH, UNSHLD	1262-110C207U	•	
	INDUCTOR/VAR., 193-306nH, UNSHLD	1262-110C250U		•
L4	INDUCTOR/VAR., 162-252nH, UNSHLD	1262-110C207U		•
	INDUCTOR/VAR., 193-306nH, UNSHLD	1262-110C250U	•	
L5	INDUCT/VAR., 162-252uH, TAP3+3/8	1263-10C05U27		•
	INDUCT/VAR., 193-306uH, TAP4+3/8	1263-10C06U35	•	
PCB	PCB, FRONT END/COIL MTG, LB VHF	4310-75500341	•	•

MECHANICAL PARTS LIST

Description	Part Number	Qty
BRACKET, CAP. MTG,V/UHF 5P F/E	3702-65001005	1
CABLE, CONFORM., 30mm/8mm/8mm	7489-C1070200	1
CABLE,SMB PLUG-OPEN,RG316,15CM	7910-WP007015	1
CABLE,SMB PLUG-OPEN,RG316,19CM	7910-WP008019	1
CABLE,SMB STR/PL-N(CSK)JK,21CM	7910-WS7NJ021	1
CASE, LB VHF, RF AMP/HELICAL	3702-65801050	1
CONN., SMB, JACK,BULKHEAD,REAR	5121-J1SC01BG	1
LOCKWASHER,M2.5,SPLIT,A2 STEEL	5814-2M5LK00S	18
NUT, PRESS,M2.5,5.6mmOD,PC MNT	5833-T2M55615	12
SCREW, M2.5 x 25 PAN/PHIL., A2	5812-2M5PP25S	18
SCREW, M3 X 6, FLAT/PHIL., A2	5812-3M0FP06S	4
SHIELD, V/UHF F/E AMP-LO DIVDR	3702-67301122	1
SHIELD, V/UHF F/E AMP-RF DIVDR	3702-67301123	1
SHIELD, V/UHF F/END AMP - WALL	3702-67301120	1
STANDOFF,5.56mmOD,4mmL,M2.5,SW	5927-5S4BM25T	6
WIRE, TFE/STRAND., 24AWG, RED	7121-24S19362	20cm

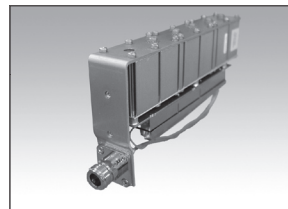

REVISION HISTORY

Revision	Date	ECO	Description
1	July 97		First Issue
1-0-1	Apr 2004		Updated document to new format

