

Selectone

Tone Signalling • Remote Controls

Manual Number: M501-6040

June 3, 1991

Revision: (91015)

USER'S GUIDE TO INSTALLATION AND OPERATION

MODEL ST-150 DCS/CTCSS ENCODER/DECODER

TABLE OF CONTENTS

SPECIFICATIONS	3
DESCRIPTION:	
General	4
CTCSS Operation	4
DCS Operation	5
Transmit Limit Time	5
Transmit Penalty Time	5
Channel Busy Lockout	5
RADIO INTERFACE	6
OUTPUT LEVEL:	
CTCSS Applications	8
DCS Applications	8
INSTALLATION:	
Factory Shipping Conditions	9
Mounting	9
Solder Jumpers	9
TONE SELECTION	10
MEMORIZING:	
DCS Code or Special Tone	11
DCS Transmit Signal Inversion	13
CUSTOM CONFIGURATION:	
Transmit Limit Time	14
Penalty Time	15
Changing Interface Conditions	15
Changing Decode/Mute Output	15
SPECIAL FEATURES:	
Channel Busy Inhibit	16
Four-code Single-Ground Operation	17
Remote Tone Selection Operation	17
WARRANTY POLICY	20

TABLES/DIAGRAMS

Frequency Look-Up Table (Table 1)	10
Jumper Table (Table 2)	10
Look-Up Table for Special Frequencies and/or Codes (Table 3) ..	13
Schematic Diagram	18 & 19
Component Locator	18 & 19

SPECIFICATIONS

Operating Voltage:	5.5Vdc to 16Vdc
Operating Current:	Less than 10mAdc
Frequency/Code Range:	38 EIA frequencies + 8 Memorized CTCSS or DCS codes
Temperature Range:	-30°C to +60°C
Frequency Accuracy:	Exceeds EIA RS-220A within $\pm .2\%$ of EIA standard
Encode Output Level:	Adjustable 0 to greater than .77Vrms
Encode Distortion:	Less than 3% THD
Decode Input Level:	15mVrms to 1Vrms
Decode Input Z:	Greater than 100K
Hi-Pass Filter:	May be muted by decode output
Decode Activate:	Field selectable (+) or (-) logic
Decode Output:	Open-collector sink to (-) Supply or source (+) voltage. Four possible output conditions or Hi-Pass filter muting.
Decode/Mute Output:	40mAdc
PTT Output	200mAdc
Channel Busy Input:	Adjustable level
Interface:	18" flying leads terminated on the board (ST-150L) or at miniature low profile connector (ST-150)
Size ST-150:	1.900" L x .825" W x .225" H 48mm x 21mm x 6mm
ST-150L:	1.900" L x .825" W x .193" H 48mm x 21mm x 4mm

Specifications are subject to change without notice.

DESCRIPTION

GENERAL

The ST-150 is a DCS/CTCSS Encoder/Decoder with a Transmit Limit Timer. Its small size is derived from use of surface mount and "chip on board" manufacturing technologies. It features a universal design for easy interface to most radio squelch circuits, and is small enough to be mounted in a mobile or portable radio where space is a factor. A Busy Channel Lock-out feature is provided for systems requiring this.

The ST-150L is a low-profile version of the ST-150 without the connector and with the radio interface wires soldered directly to the P.C.B.

Like other Selectone CTCSS products, the ST-150 is fully compatible with all major CTCSS systems, including Motorola "Private Line", General Electric "Channel Guard", and E.F.Johnson "Call Guard". In addition, the ST-150 is also compatible with DCS (Digital Coded Squelch) systems similar to Motorola's "Digital Private Line" and General Electric's "Digital Channel Guard".

The ST-150 is shipped configured as a basic programmable CTCSS Encode/Decode unit with 37 EIA standard CTCSS tones and 97.4Hz available. The required CTCSS frequency is selected by installation of solder-pad jumpers. The interface input and output conditions have been factory set to suit most applications. These conditions may be changed by "sensing" the condition as connected to the radio and memorizing that condition. Refer to the INSTALLATION and TONE SELECTION sections of this manual.

The ST-150 may be configured in the field as a DCS (Digital Coded Squelch) Encode/Decode unit. DCS codes are selected by memorizing an "ON THE AIR" code. Refer to the MEMORIZING section of this manual.

For high volume or OEM applications the ST-906 Programming Fixture is available. This fixture allows programming of all of the ST-150 codes, frequencies, and other operating parameters directly from an IBM P.C. compatible computer. The 46 possible user addresses may be customized to suit a unique binary address scheme.

Multiple tone/code selection is also possible. Refer to the CUSTOM CONFIGURATION section of this manual.

We encourage you to take advantage of our free application assistance, particularly for DCS applications since most radios do not support DCS application by connection to a dedicated connector. Application information is available or can be developed for most radio models. If you would like application details for a specific radio, please call us TOLL FREE at (800) 227-0376. Together we may be able to save you some time and money.

CTCSS OPERATION

The required CTCSS frequency may be set by installation of solder-pad jumpers. The six jumpers are a binary input to a look-up table that follows the binary selection pattern used by our ST-138. Refer to the TONE SELECTION section.

For special field applications, eight binary codes have been reserved to memorize any tone between 15 and 255Hz. The memorized tone is then stored in a non-volatile EEPROM memory. Once memorized, the tone attains the same crystal controlled accuracy and stability as non-memorized tones/frequencies. Refer to the MEMORIZING section for specifics.

For flexibility of application, six wire hole pads have been provided for installations where it is desirable to remote the tone selection lines. Four of these wires may be used to operate the ST-150 as a single-ground multi-code unit. Refer to the SPECIAL FEATURES section.

DCS OPERATION

The ST-150 is set to the required DCS code by selecting one of the eight special binary codes reserved for memorizing, then memorizing the desired code from an "ON THE AIR" signal. The memorized code is then stored in a non-volatile EEPROM memory. Once memorized, the code attains the same crystal controlled accuracy and stability as non-memorized tones/frequencies. Refer to the MEMORIZING section of this manual.

It is possible to memorize up to 8 DCS codes and use them as required by selecting the appropriate look-up table position. Refer to MEMORIZING section for specifics.

TRANSMIT LIMIT TIME

The ST-150 is capable of providing a Transmit Limit Time function to reduce system interference susceptibility or to comply with government requirements. To use this function, the PTT line from the microphone must be opened. The ST-150 is then placed in series with the PTT line. The Transmit Limit Time is preset-set at the factory to 120 seconds (2 min.). Refer to the CUSTOM CONFIGURATION section to make changes.

TRANSMIT PENALTY TIME

In applications where there are system abusers, the use of a simple Transmit Limit Timer may not prove effective since the abuser simply un-keys then immediately keys up again. The ST-150 provides a solution for this problem. Upon timeout of the Limit Timer, transmission is inhibited for the period of the penalty time. During the penalty time, any time spent attempting to transmit is added to the penalty time. This feature is disabled as shipped from the factory. Refer to the CUSTOM CONFIGURATION section to enable this feature.

CHANNEL BUSY LOCKOUT

In some shared repeater systems it is desirable to prevent co-users from "capturing" the channel in the midst of a conversation. The Busy Channel Lockout feature senses the presence of signal and if tone decode has occurred. If signal is present but tone decode has not occurred, PTT is inhibited. On a repeater system this would require the current users' tone to be encoded during transmit hang time. This feature is disabled as shipped from the factory. Refer to the SPECIAL FEATURES section to enable.

RADIO INTERFACE

[3] Positive (+) Supply (RED)

Connect to (+) Supply (5.5Vdc to 16Vdc)

[9] Negative (-) Supply (BLACK)

Connect to System (-) (Ground)

[12] Tone Input (GREEN)

Jumpered to Hi-Pass Filter Input by JU7. Connect directly to the FM receiver detector audio output. Opening the audio path at this point will allow insertion of the Hi-Pass Filter. If it is not practical to open the audio path at this point, refer to Hi-Pass Filter Input (BLUE).

[11] Hi-Pass Filter Input (BLUE)

Required only when Tone Input (Green) cannot be used for Hi-Pass Filter Input. Remove JU7 for applications where separate decoder input and tone filter input is necessary. Hi-Pass Filter Input audio should be taken at the most convenient point.

[1] Hi-Pass Filter Output (WHT/BLU)

Connect to place the Hi-Pass Filter in series with receiver audio path.

NOTE



NOTE: The Hi-Pass Filter will not work in high level audio stages, such as speaker leads.

[4] Decode/Mute Output (WHT/ORG)

One of three basic output conditions with invert is available:

1. For applications where the radio mute point must be held at Negative (-) Supply (Ground) during mute, JU12 must be installed and JU10 and JU11 must be removed. (factory shipping condition)
2. For applications where the radio mute point must be held Positive (+) during mute, JU11 must be installed and JU10 and JU12 must be removed.
3. For applications where neither 1 nor 2 are applicable, Hi-Pass Filter muting is available by installing JU10 and removing JU11 and JU12.

Refer to the INSTALLATION and/or MEMORIZING sections of this manual to invert the operation of this output.

[7] Decode Enable Input (BROWN)

Primary control of Decode/Mute functions. Connect to Negative (-) Supply (Ground) through your Monitor/Hook-Switch to mute the radio. Open from Negative (-) Supply (Ground) to monitor. If your monitor switch closes to Negative (-) Supply (Ground) to monitor, Refer to the CUSTOM CONFIGURATION section of this manual to invert this input.

[2] Channel Busy Input (VIOLET)

This input is referenced to an adjustable threshold. Adjustment is made by R20. Connect this input to a point in the radio providing channel busy indication. This point should be a D.C. level change and should indicate carrier only (no Decode/Mute Output interaction). If you will be using this feature, refer to SPECIAL FEATURES section for detailed instructions.

[13] Tone Output (WHT/GRN)

Most F.M. two-way radios make provisions for CTCSS modulation. This point is generally after the speech modulation limiter, and near the voice deviation control. The Encode Output level is adjusted by R29. The Tone Output impedance (Z) of the ST-150 as shipped from the factory is approximately 150K. This may be reduced by shorting JU8 and/or JU9. JU8 will parallel a 51K resistor, reducing the output Z. JU9 will parallel a 1.0K resistor further reducing the output Z. Refer to OUTPUT LEVEL for more details.

[6] PTT Input (YELLOW)

This input is required to enable CTCSS or DCS encode and PTT Output (timed/delayed). Connect to PTT from microphone. For DCS, Channel Busy Inhibit, or where the Transmit Limit Timer is used, the PTT output from the mic to the transmitter must be opened and the ST-150 placed in series with the PTT circuit. This is the PTT input to the ST-150.

[10] PTT Output (timed/delayed) (BLK/YEL)

Produces closure to Negative (-) Supply (Ground) during transmit. For applications using the Transmit Limit Timer, Channel Busy Inhibit and/or DCS squelch tail elimination function, the PTT line from the mic must be opened and the ST-150 placed in series. Connect to the transmitter PTT input. This is the PTT output from the ST-150.

[5] Warning Tone Output (BLK/ORG)

A warning tone is output on this line when the Transmit Limit Time has been exceeded, Channel Busy Inhibit is active, or Penalty Time is imposed. The tone will continue until the PTT input is removed. Connect to a point in the radio where the warning tone may be heard through the speaker. Directly to the speaker is NOT acceptable. Remember: though the PTT from the microphone is active (keyed), the ST-150 has UN-KEYED the transmitter when the warning tone is active.

[8] Programming Input (BLK/BRN)

Not used in normal operation. When connected to Negative (-) Supply at power-up has the same function as JU13 shorted. Use of this wire during installation might be preferable. Refer to the INSTALLATION and MEMORIZING sections for details.

OUTPUT LEVEL

The Encode Output level is adjusted by R29. A CTCSS or DCS deviation of $\pm 750\text{Hz}$ is recommended for narrow band FM. The Tone Output impedance (Z) of the ST-150 as shipped from the factory is approximately 150K. This may be reduced by shorting one or two jumpers. Refer to Tone Output (WHT/GRN). The radio MUST be direct F.M. for DCS applications. You may be successful in applying DCS with a specific code to one or more P.M. transmitters. However, your success may not be repeatable even in a radio of similar manufacture. Please note that DCS presents special applications problems. Contact the Selectone Applications Engineering Department for radio application specifics.

CTCSS APPLICATIONS

If the CTCSS deviation is too low even with R29 set to maximum, short JU8 to provide a correct tone level without loading the radio modulator circuit and reducing voice modulation. If still too low, short JU9 and check the results. The ST-150 has a .22uF output coupling capacitor. Some installations may require by-passing this to obtain good low frequency modulation. Install JU15 to by-pass the capacitor. If the tone input of the radio is D.C. coupled, you should add a non-polarized capacitor in series with the Tone Output lead. Choose a value large enough to pass CTCSS.

DCS APPLICATIONS

The ST-150 has a .22uF output coupling capacitor. DCS will require by-passing this to obtain good low frequency modulation. Install JU15 to by-pass the capacitor. If the tone input of the radio is D.C. coupled or the coupling capacitor is less than 1.0uF you should add a non-polarized capacitor ($\geq 1.0\text{uF}$) in series with the Tone Output lead. If necessary, short the capacitor in the radio. If you notice significant "droop" of the DCS code, i.e. modulation level of the trailing edge of the DCS code much lower or zero from the leading edge, try a higher value capacitor to minimize "droop". Otherwise, the code input point or the radio modulator may not be suitable for DCS. If the DCS deviation is too low even with R29 set to maximum, short JU8 to provide a correct tone level without loading the radio modulator circuit and reducing voice modulation. If still too low, short JU9 and check the results.

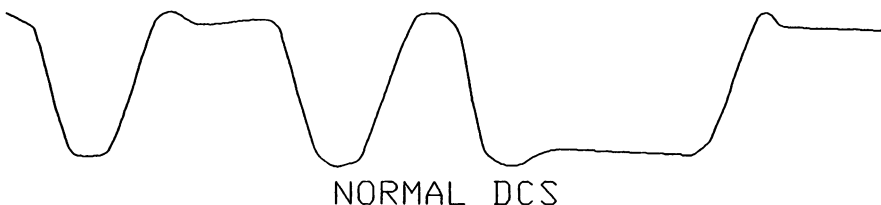
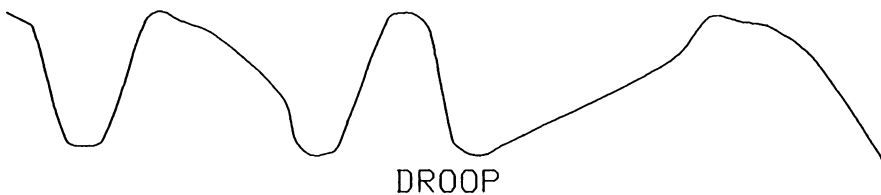

INSTALLATION

We have attempted to configure the ST-150 to require minimum installation time for most radios. If you do not have applications information for your particular radio, please call us TOLL FREE at (800) 227-0376.

The interface between the ST-150 board and the radio is by 13 wire leads on a miniature low profile connector. Most applications will not require the use of all leads. Unused leads should be removed from the connector by carefully lifting the small tab near each connection pin and pulling the wire from the connector. We recommend this method (rather than cutting wires) because it provides for reusing pins if an error is made.

FACTORY SHIPPING CONDITIONS

The ST-150 has been configured at the factory with the following conditions:

- Decode Enable Input = Ground to mute
Open to Monitor
- Decode/Mute Output = Sink to Ground
Normally ON until decode.
- PTT Input = Ground to enable encode and
PTT output High or Open during
receive
- Channel Busy Inhibit = Disabled
- CTCSS Operation = 67Hz

STOP



*If the **FACTORY SHIPPING CONDITIONS** are suitable for your application, no further set-up is necessary. Use of **DCS** or **Special Features** will require further programming. See the **MEMORIZING** and **CUSTOM CONFIGURATION** sections.*

MOUNTING

Use of a double-sided adhesive pad eliminates hardware requirements. Mount the ST-150 on a clean, dry surface, oriented to allow easy routing of the wiring to the radio. Press firmly after mounting to ensure good adhesive contact. Do not touch the adhesive or attempt to re-position the unit after mounting. If use of the adhesive pad is not practical, we have included a length of polyester tubing which may be used to insulate the ST-150 from contact with other parts of the radio. The ST-150 has been designed for maximum immunity to RF interference. However, you should locate the unit as far as possible from the radio's RF power stages. To further minimize RF problems, twist the leads together and maintain all leads at minimum length.

SOLDER JUMPERS

Due to the small size of these boards, programming and application characterization is accomplished by small solder jumper pads. Jumpers should be installed only when power is off. Use a fine tip solder iron (600° – 700° F) with a grounded tip to place a small dab of solder on the pad. A clean tip on the same iron will easily remove a jumper.

STONE SELECTION

There are 37 standard CTCSS tones and 97.4Hz available from the ST-150. Find your desired standard tone in the Frequency Look-Up Table and place solder pad jumpers at the FREQUENCY/CODE selection pads (JU1 [F1] thru JU6 [F6]) according to the table.

FREQUENCY LOOK-UP TABLE

Frequency selection is done by installing or removing the jumpers according to the following Look-Up Table.

JUMPERS: (0=IN; 1=OUT)

FREQ IN Hz	JUMPER SECTION						FREQ IN Hz	JUMPER SECTION					
	1	2	3	4	5	6		1	2	3	4	5	6
67.0	1	1	1	1	1	1	131.8	0	0	1	0	0	1
71.9	0	1	1	1	1	1	136.5	0	1	1	0	0	0
74.4	1	1	1	1	1	0	141.3	0	0	1	0	0	0
77.0	0	0	1	1	1	1	146.2	0	1	0	1	1	1
79.7	1	1	1	1	0	1	151.4	0	0	0	1	1	1
82.5	0	1	1	1	1	0	156.7	0	1	0	1	1	0
85.4	1	1	1	1	0	0	162.2	0	0	0	1	1	0
88.5	0	0	1	1	1	0	167.9	0	1	0	1	0	1
91.5	1	1	1	0	1	1	173.8	0	0	0	1	0	1
94.8	0	1	1	1	0	1	179.9	0	1	0	1	0	0
97.4	1	1	1	0	1	0	186.2	0	0	0	1	0	0
100.0	0	0	1	1	0	1	192.8	0	1	0	0	1	1
103.5	0	1	1	1	0	0	203.5	0	0	0	0	1	1
107.2	0	0	1	1	0	0	210.7	0	1	0	0	1	0
110.9	0	1	1	0	1	1	218.1	0	0	0	0	1	0
114.8	0	0	1	0	1	1	225.7	0	1	0	0	0	1
118.8	0	1	1	0	1	0	233.6	0	0	0	0	0	1
123.0	0	0	1	0	1	0	241.8	0	1	0	0	0	0
127.3	0	1	1	0	0	1	250.3	0	0	0	0	0	0
							OFF	1	1	0	0	0	0

Table #1

JUMPER TABLE

JUMPER	DESCRIPTION	USE
JU1-JU6	Tone/Code address selection	Short according to the Look-Up Table.
JU7	Connects Tone Input to High Pass Filter Input	Shorted at factory. Open for separate inputs.
JU8	Changes Tone Output Impedance	Short to parallel 51K with 150K.
JU9	Changes Tone Output Impedance	Short to parallel 1.0K with 150K.
JU10	Provides High Pass Filter Mute	Short for High Pass Filter Mute. (JU11 & JU12 MUST be OPEN)
JU11	Provides switched +Vdc to Decode/Mute Output	Short for +Vdc at Decode/Mute Output. (JU10 & JU12 MUST be OPEN)
JU12	Provides switched (-) supply to Decode/Mute Output	Short for (-) supply at Decode/Mute Output. (JU10 & JU11 MUST be OPEN)
JU13 ONLY	Enables Tone and Interface memorize	Short before Power-up to memorize. Open for operate.
JU14 ONLY	Enables DCS and Interface memorize	Short before Power-up to memorize. Open for operate.
Both JU13 & JU14	Enables Custom Configure MODE #1	Short before Power-up to configure Transmit Limit Timer and Decode/Mute Output.
JU15	By-pass Encode Output Coupling capacitor	Short for direct coupling. Open for DC blocking.
JU16	Enables Custom Configure MODE #2	Short before Power-up to configure Penalty Time and Enable/Disable Channel Busy Inhibit.

Table 2

MEMORIZING

DCS CODE or SPECIAL TONE

The MEMORIZE method must be used for DCS. You can memorize any valid DCS code or any tone from 15 to 255Hz. The decode bandwidth for tone will be equal to or less than $\pm 1.5\%$ of the memorized frequency.

The Decode/Mute output is used to indicate successful completion of most of the operations in the following procedures. Therefore, it is necessary to configure this output to the "Muted" condition first.

1. Remove power
2. Short JU10, JU11, or JU12 (only one!) for the desired output.
3. Decode/Mute Output Normally ON or Normally OFF
 - a. Normally ON: Leave Decode Enable Input open or high.
 - b. Normally OFF: The Decode Enable Input should be Grounded or low.
4. Short BOTH JU13 and JU14.
5. Apply power.
6. Remove power.
7. Open JU13 and JU14

NOTE

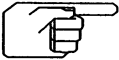

This has only determined Decode/Mute. Decode Enable Input will be Memorized later.

The MEMORIZE mode is enabled by shorting one of two jumpers, JU13 or JU14. Short one or the other (NOT both). JU13 is shorted to memorize a tone and the interface connections. JU14 is shorted to memorize a DCS code and the interface connections.

While in the Memorize mode the ST-150 will "sense" the status of the following radio interface connections: Decode Enable Input, PTT Input, and Channel Busy Input. It is best to follow this procedure after all of the necessary connections to the radio have been made. The ST-150 "assumes" the radio is in the receive mode with signal present and microphone off hook, i.e., if PTT Input is "sensed" high, then the opposite (low) must be transmit. If using Channel Busy Inhibit feature, refer to SPECIAL FEATURES section.

Up to eight (8) DCS codes and/or tones may be memorized. When operating the ST-150 as a single code device, jumpers JU1 through JU6 will be used to select the memory address. For multi-code/tone operation wire-outs F1 through F6 will be used. In both cases JU3 [F3] is used to cause transmit DCS code to be inverted. SHORT (0) is inverted. This has no effect on TONE.

1. Remove power
2. Short JU1 [F1] through JU6 [F6] to select one of the eight special memory addresses. SP1 (1 0 1 1 1 1) is recommended for single code operation since a maximum of two jumpers are required. Refer to the Look-Up Table for Special Frequencies and/or Codes (Table 3)
3. TONE or DCS
 - a. TONE: Short JU13 leave JU14 Open
 - b. DCS: Short JU14 leave JU13 Open.
4. Place the Decode Enable Input in the OFF-HOOK or MONITOR state.
5. Apply a fully quieting RF signal modulated with the desired CTCSS tone or DCS code to the receiver
6. Apply power.
7. The receiver will MUTE upon successful completion of memorization (even though the Decode Enable Input seems to be in Monitor).
8. Remove power.
9. Remove JU13 or JU14, which ever was selected in step 3.

NOTE

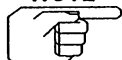

The Tone/Code and all of the input/output states have now been Memorized according to your radio installation/operation.

For multi-code/tone applications repeat steps 1 through 7 for each additional memory location.

DCS TRANSMIT SIGNAL INVERSION

JU3 is used to invert the transmit signal of the DCS code. To determine JU3 [F3] simply transmit from this radio to another radio in the system (same radio as used for the ON THE AIR signal). If it does not decode, short JU3 (ground F3) and check the results. If installing a new system using a bench DCS encoder, program two radios with ST-150 decoders. Transmit from one ST-150 installed radio to the other. If it does not decode, short JU3 (ground F3) on the transmitting unit and check the results. The JU3 [F3] setting should be the same for all radios of the same model and manufacturer in the system.

LOOK-UP TABLE FOR SPECIAL FREQUENCIES and/or CODES

JUMPERS: (0=IN; 1=OUT)

X = TONE - don't care

DCS - Encode Invert = 0

LOCATION	JUMPER SECTION					
	1	2	3	4	5	6
SP1	1	0	X	1	1	1
SP2	1	0	X	1	1	0
SP3	1	0	X	1	0	1
SP4	1	0	X	0	1	1
SP5	1	0	X	1	0	0
SP6	1	0	X	0	1	0
SP7	1	0	X	0	0	1
SP8	1	0	X	0	0	0

Table 3

Note that locations SP1, SP2, SP3, and SP4 may be used to provide a four-code single-ground unit. Refer to FOUR-CODE SINGLE-GROUND.

CUSTOM CONFIGURATION

There are two configuration modes. Configuration mode #1 is enabled by shorting BOTH JU13 and JU14. Configuration mode #2 is enabled by shorting JU16 only. Interface connections are NOT memorized in either of these modes.

Mode #1 will allow adjustment of the Transmit Limit Timer and allow setting Decode/Mute output normally ON or normally OFF until decode.

Mode #2 will allow setting Penalty Time and Enable or Disable Channel Busy Inhibit.

The Transmit Limit Time and the Penalty Time are changed by memorizing a tone that meets the following equation:

$$\text{TIME in Minutes} = F_p / 100$$

Where F_p is the programming frequency and can be any frequency between 30Hz and 900Hz

EXAMPLES: (30Hz/100 = .3 Min = 18 Sec)
(900Hz/100 = 9 Minutes).

Programming a frequency of 975Hz \pm 2.5% (950Hz to 1000Hz), disables the function.

TRANSMIT LIMIT TIME

Although this procedure is for setting the limit timer, the Decode/Mute Output condition is also set. This procedure may be used at any time without effecting other previously memorized items. Factory set to 2.0 minutes (120 sec.).

1. Remove power.
2. Install JU13 and JU14, (both).
3. Decode/Mute Output Normally ON or Normally OFF
 - a. Normally ON: Decode Enable Input should be open or high.
 - b. Normally OFF: The Decode Enable Input should be Grounded or low.
4. Send the required tone (F_p) to the radio via an R.F. signal generator. On reapplication of power the radio will be un-muted and the programming tone will be heard in the radio speaker until the memorizing sequence is complete (approx. 5 sec.). When memorizing is complete the radio will mute.
5. Apply power. When memorizing is complete the radio will mute.
6. Remove power.
7. Open JU13 and JU14.

PENALTY TIME

Although this procedure is for setting the penalty time, the Channel Busy Inhibit will also be effected. This procedure may be used at any time without effecting other previously memorized items. The Penalty Time is Disabled as shipped from the factory.

1. Remove power.
2. Install JU16 only.
3. Channel Busy Inhibit Enable/Disable
 - a. Enable: Decode Enable Input should be Grounded or low.
 - b. Disable: Decode Enable Input should be High or open. (Must be disabled if NOT used)
4. Send the required tone (Fp) to the radio via an R.F. signal generator. On reapplication of power the radio will be un-muted and the programming tone will be heard in the radio speaker until the memorizing sequence is complete (approx. 5 sec.). When memorizing is complete the radio will mute.
5. Apply power. When memorizing is complete the radio will mute.
6. Remove power.
7. Open JU16.

CHANGING INTERFACE CONDITIONS

The ST-150 will "sense" and memorize the status of the following radio interface connections: Decode Enable Input, PTT Input, and Channel Busy Input. To set the ST-150 according to your radio's parameters, make all of the necessary connections to the radio. Then set up the radio in the receive mode with signal present and microphone off hook. With power removed, ground the Programming Input (BLK/BRN) or short JU13. Momentarily apply power (OFF/ON/OFF). Disconnect the BLK/BRN wire (open JU13). The ST-150 now "knows" the interface parameters of your radio. If using Channel Busy Inhibit feature, refer to SPECIAL FEATURES section.

CHANGING DECODE/MUTE OUTPUT

The Decode/Mute output is factory set to be normally ON until decode. If you need to change this use the following procedure.

1. Remove power
2. Short JU10, JU11, or JU12 (only one!) for the desired output. (JU12 shorted at factory) Refer to DECODE MUTE OUTPUT in the RADIO INTERFACE section and to the JUMPER TABLE.
3. Decode/Mute Output Normally ON or Normally OFF
 - a. Normally ON: Leave Decode Enable Input open or high.
 - b. Normally OFF: The Decode Enable Input should be Grounded or low.
4. Short BOTH JU13 and JU14.
5. Apply power.
6. Remove power.
7. Open JU13 and JU14

SPECIAL FEATURES

CHANNEL BUSY INHIBIT

This feature is disabled as shipped from the factory. Use of this feature requires connection of the **Channel Busy Input (VIO)**, **PTT Input (YEL)**, and **PTT Output (BLK/YEL)**. The Channel Busy Input has an adjustable threshold reference which you will have to set according to your radio and the connection point you have chosen. Choose a point that is a D.C. level change on carrier only. After connection to the radio, determine the proper threshold setting from the following steps:

1. Set up the radio in the receive mode, carrier squelch, squelch closed (no noise), no signal present.
2. Measure the voltage at the VIOLET wire. Note this Voltage [V_{sq}].
3. Apply a fully quieting signal to the receiver.
4. Measure the voltage at the VIOLET wire. Note this Voltage [V_{usq}].
5. Add the figure from step 2 to the figure from step 4 and divide the sum in half [$(V_{sq} + V_{usq})/2$].
6. Multiply the result of step 5 by 0.15 [Voltage divider factor]. This figure is your threshold reference. (V_{ref})

To adjust the Channel Busy Input for this reference, measure the voltage at the wiper of R20. This may be done directly on the adjusting screw or at pin 2 of U1. Adjust R20 until you obtain the figure determined in step 6. (V_{ref})

In summary:

$$V_{ref} = \frac{(V_{sq} + V_{usq})}{2} \times 0.15$$

Where: V_{ref} = Threshold Reference voltage.

V_{sq} = Voltage at Channel Busy Input, Rx squelched, no signal.

V_{usq} = Voltage at Channel Busy Input, Rx unsquelched, signal.

0.15 = Voltage divider factor.

With the threshold reference properly adjusted you will now have to "write" to the microprocessor what the SIGNAL PRESENT condition is.

1. set up the radio in the receive mode, signal applied, and microphone off hook.
2. Remove power.
3. Ground the Programming Input (BLK/BRN) wire or short JU13.
4. Momentarily apply power, OFF/ON/OFF.
5. Disconnect the BLK/BRN wire or open JU13.

You will now have to enable the Inhibit function.

1. With power OFF short JU16.
2. The Decode Enable Input (BRN) should be grounded or low when power is reapplied.
3. Momentarily apply power, OFF/ON/OFF.
4. Open JU16.

The ST-150 is now set up to inhibit transmit PTT if the channel is busy by a user whose tone is not the same as this user.

FOUR-CODE SINGLE-GROUND OPERATION

You can memorize up to four tones/codes in the special memory and select the desired tone/code via a single ground on one of three wires. To use this feature, short JU2 [F2] and install wires at F4, F5 and F6. Refer to the MEMORIZING section and memorize tones/codes in memory locations SP1 to SP4 (as many as you require up to four). Once that is done, no wires grounded will encode/decode memory SP1, F6 grounded will encode/decode SP2, F5 grounded selects SP3, and F4 grounded selects SP4. The status of these wires is observed only during decode, any change during encode (transmit) will not affect the tone/code.

REMOTE TONE SELECTION OPERATION

By adding wires to F1 through F6, remote tone/code selection is possible. The address lines are internally pulled high and may be externally held low. Selection of factory loaded tones and the special memory addresses is possible. By use of the ST-906 a unique binary address and tone/code scheme may be used. For more detailed information please contact the factory TOLL FREE at (800) 227-0376.

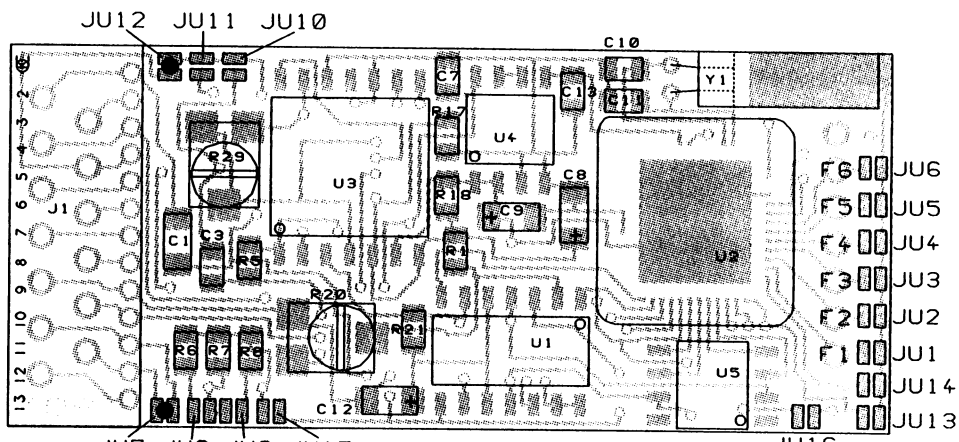
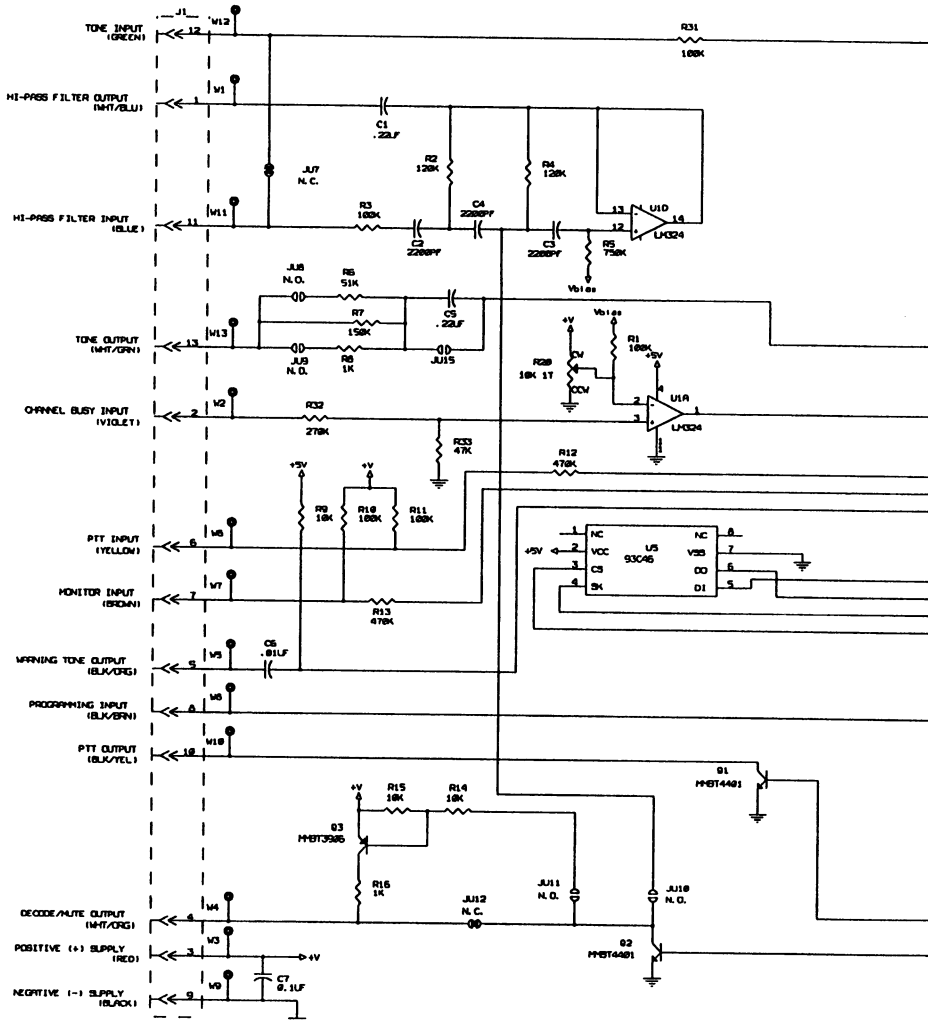

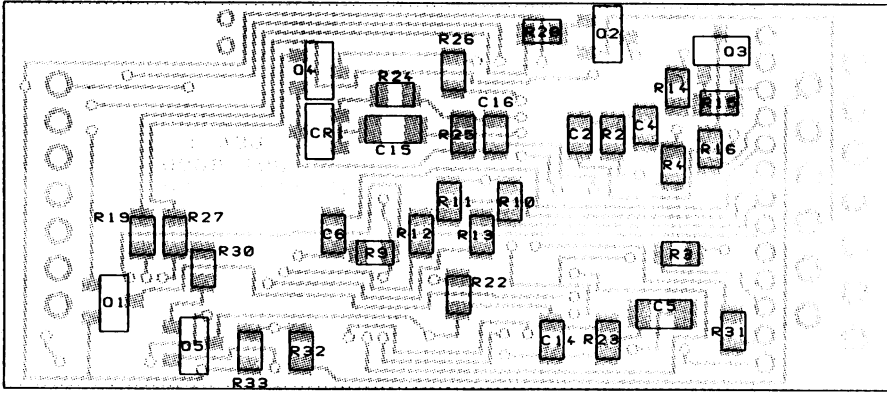
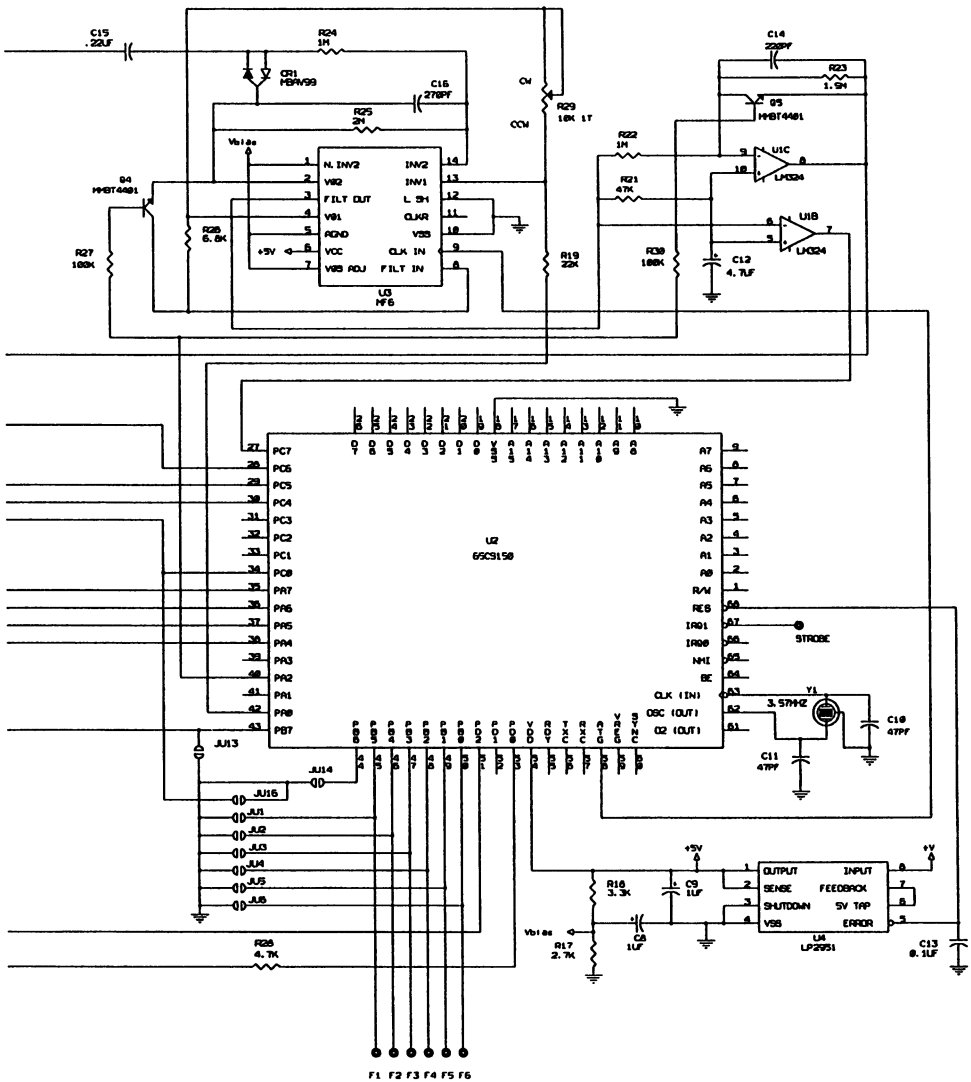

BOTTOM SIDE
19

WARRANTY POLICY

All standard Selectone products are guaranteed to meet or exceed published performance specifications and are warranted against defects in material and workmanship for a period of five years from date of purchase. Special configurations and nonstandard systems are warranted for a period of one year.

If any standard Selectone product fails to operate within the first 90 days from the date of purchase, Selectone will immediately send a replacement unit postpaid via airmail or UPS Blue Label (air), and will issue full credit, including freight, upon the return of defective unit(s). For special warranty replacement service, call the Selectone Customer Service Department TOLL FREE at 1-800-227-0376. C.O.D. customers must return defective equipment prior to exchange or will receive the replacement C.O.D. with credit issued only on return of the defective equipment.

After 90 days, this warranty is specifically limited to correction of the defects by factory repair or replacement of faulty equipment or parts.

All warranty repairs must be performed at the Selectone factory in Hayward, California. No credit will be given for unauthorized repair work attempted by the customer. Any unauthorized alteration or modification of the equipment, damage by external sources, or removal or alteration of the serial number label or date code, will void the warranty. Specifically excluded from this warranty are batteries, LED's, fuses, lamps, and damage caused by lightning, power surges, or mechanical abuse.

Equipment for repair may be returned to the factory without prior written authorization; however, a note must be sent with the packing list briefly describing the nature of the defect.

REVIEWED BY:

Engr: JNS

Mktg: PHOR

Prod: FAB

Print Date: 6-15-91

Manual #: M501-6040

Revision: (91015)

Last Edit Date: June 3, 1991

By: Bambi Benne

Selectone

FOR FURTHER INFORMATION OR TECHNICAL ASSISTANCE,
CONTACT OUR APPLICATION ENGINEERING DEPARTMENT:

23278 Bernhardt Street • Hayward, CA. 94545

(415) 887-1950 • TOLL FREE: (800) 227-0376

FAX: (415) 887-4011