

**COMMUNICATIONS  
SPECIALISTS  
MODEL TP-3200  
SHARED REPEATER  
TONE PANEL**

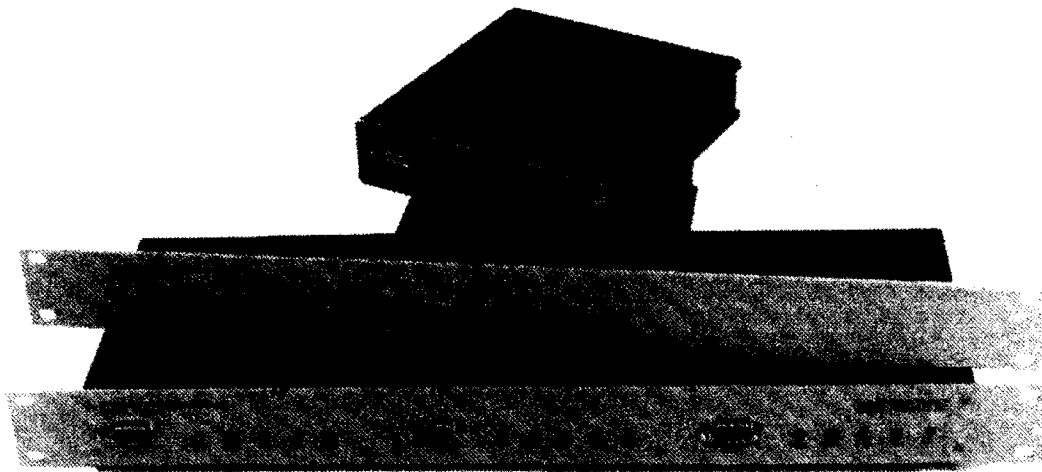

**COMMUNICATIONS SPECIALISTS, INC.**  
426 WEST TAFT AVENUE • ORANGE, CA 92865-4296  
(714) 998-3021 • FAX (714) 974-3420  
Entire U.S.A. (800) 854-0547 • FAX (800) 850-0547  
<http://www.com-spec.com>

**FULL  
FEATURED**

## **TP-3200 SHARED REPEATER TONE PANEL**

The TP-3200 is the complete tone and control interface between the repeater receiver and transmitter. It is microprocessor controlled for excellent frequency accuracy and stability. DSP Algorithms are incorporated into the software for enhanced decode sensitivity and talk-off rejection. The TP-3200 also functions as a desktop CTCSS, DCS, and DTMF decoder with its RS-232 port and advanced, comprehensive tone logging features for shop use. Programming is accomplished through its RS-232 port to a basic terminal or any PC with communications software.

### **STANDARD FEATURES**

- ◆ 51 CTCSS Tones
- ◆ 106 DCS Codes
- ◆ Supports 157 Repeater Subscribers
- ◆ Signaling Formats; CTCSS, DCS & DTMF
- ◆ On-Line Computer Help
- ◆ Remote Programming over the air with DTMF or with Modem over Landline
- ◆ Guaranteed Remote Reset
- ◆ Time & Hit Accumulation of ALL 157 Tones and Codes per subscriber
- ◆ Air Time Loading & Analysis Graphs
- ◆ COS Input, Polarity Selectable
- ◆ Non Volatile Memory retains programming even if power loss occurs
- ◆ Static & Lightning Protection built-in
- ◆ EMI Filtering for complete immunity to RF
- ◆ Auto Self-Test
- ◆ Ultra Low Current Drain for Solar & Battery operated sites, 100ma Nominal @ 12VDC
- ◆ Rear Panel Adjustments
- ◆ Will not False on Adjacent Tones, even those with Reverse Burst
- ◆ Pre-Paid Airtime Feature
- ◆ Busy Channel Lockout prevents "Barge-In's"
- ◆ Stuck Mic Identification
- ◆ Time-Out Warning Tones
- ◆ Five LED's Display Status
- ◆ Carrier Access Mode
- ◆ Hooded DB-9 Connector with 7 Color-Coded 6' Flying Leads (3 shielded)
- ◆ Size: TP-3200RM 19" wide x 6" deep x 1.7" high  
TP-3200D 5.4" wide x 5.8" deep x 1.4" high
- ◆ Toll-Free Support
- ◆ Five Year Warranty when returned to the factory for repair
- ◆ One Day Delivery
- ◆ "Start-up Kit" includes Wall Mount D.C. Power Supply with DB9 Connector attached, two 10' RS-232 Computer Interface Cables and a 3.5" Communications Software Disk. (Please specify if 5-1/4" disk is needed.)

<b>TP-3200RM-A</b> Single Rack Mount Version with one TP-3200.....	<b>\$279.95 each</b>
<b>TP-3200RM-B</b> Triple Rack Mount Version with one TP-3200.....	<b>\$279.95 each</b>
<b>TP-3200D</b> Table Top Version.....	<b>\$269.95 each</b>

# TP-3200 SHARED REPEATER TONE PANEL

## PROGRAMMING FEATURES

- ◆ 51 CTCSS Codes
- ◆ 106 DCS Codes
- ◆ Repeater Enable/Disable
- ◆ Repeater CW ID
- ◆ Programmable CW ID per subscriber
- ◆ CW ID Interval per subscriber
- ◆ CW ID Interval (System)
- ◆ Anti-Kerchunk Timer
- ◆ Stuck Mic Activity Timer
- ◆ DCS Input Polarity
- ◆ DCS Output Polarity
- ◆ COR with Polarity Select
- ◆ Programming Mode Access Code is programmable
- ◆ Hog Timer, Hog Idle & Hog Monitor Timers
- ◆ Programmable Courtesy Tone per subscriber
- ◆ Programmable Reserve Tone
- ◆ Time & Hit Counters Record the time of ALL CTCSS & DCS Codes on the repeater channel
- ◆ Regenerated Tone can be the same or different for ALL CTCSS & DCS Codes
- ◆ Real Time Display shows all Received Tones & Codes as they occur, even if not active in the panel
- ◆ Panel can be used as Stand Alone Tone & Code Display of ALL 51 CTCSS, 106 DCS & 16 DTMF Codes
- ◆ Will not False on Adjacent Tones, even those with Reverse Burst
- ◆ Remotely Programmable by DTMF or Local Programming through menu driven RS-232 Port, or with Modem on Landline
- ◆ Pre-Paid Customer Time Blocks
- ◆ Remote Enable/Disable of ALL Tones & Codes
- ◆ DTMF-DTMF Regeneration
- ◆ Global User Programming
- ◆ Programmable Hang Time (Carrier Delay) per subscriber
- ◆ Barge-In Enable/Disable per subscriber
- ◆ Hog Timer Enable/Disable per subscriber
- ◆ Regenerated CTCSS Tone or DCS Code Programmable to turn off at the start or end of the Carrier Delay per subscriber
- ◆ Cross Tone, Cross Code Encoding per subscriber
- ◆ Direct CTCSS Frequency and DCS Code Entry
- ◆ Test Procedure to set all Repeater Levels is built-in

## ALL TONES & CODES LISTED BELOW ARE INCLUDED IN THE TP-3200

51 CTCSS Tones					106 DCS Codes										DTMF Tones
63.0	94.8	136.5	177.3	218.1	017	053	125	172	251	315	411	462	565	712	0 *
67.0	97.4	141.3	179.9	225.7	023	054	131	174	252	325	412	464	606	723	1 #
69.4	100.0	146.2	183.5	229.1	025	065	132	205	255	331	413	465	612	731	2 A
71.9	103.5	151.4	186.2	233.6	026	071	134	212	261	332	423	466	624	732	3 B
74.4	107.2	156.7	189.9	241.8	031	072	143	223	263	343	431	503	627	734	4 C
77.0	110.9	159.8	192.8	250.3	032	073	145	225	265	346	432	506	631	743	5 D
79.7	114.8	162.2	196.6	254.1	036	074	152	226	266	351	445	516	632	754	6
82.5	118.8	165.5	199.5		043	114	155	243	271	356	446	523	654		7
85.4	123.0	167.9	203.5		047	115	156	244	274	364	452	526	662		8
88.5	127.3	171.3	206.5		050	116	162	245	306	365	454	532	664		9
91.5	131.8	173.8	210.7		051	122	165	246	311	371	455	546	703		

# MODEL TP-3200 SHARED REPEATER TONE PANEL

## TABLE OF CONTENTS

SECTION	DESCRIPTION	PAGE
I	STANDARD FEATURES	
II	PROGRAMMING FEATURES	
III	TABLE OF CONTENTS	
IV	GENERAL DESCRIPTION	1
V	OPERATION Indicators Power up Remote Reset	1
VI	INSTALLATION PROCEDURE	3
VII	COMPUTER PROGRAMMING	5
VIII	ON LINE MENUS Main Menu User Menu Global User Menu AirTime Accumulators System Parameters 1 System Parameters 2 Level Adjustments	6
IX	SCHEMATIC DIAGRAM	10
X	DTMF PROGRAMMING	15
XI	DATA INTERROGATION	19
XII	PICTORIAL DIAGRAMS Printed Circuit Board Layout Block Diagram	20
XIII	PARTS LIST	22
XIV	WARRANTY STATEMENT	Back Cover

## SECTION IV

### GENERAL DESCRIPTION

The Communications Specialists Model TP-3200 is a compact 19" rack mount Shared Repeater Tone Panel for use on shared repeater stations that utilize CTCSS signaling tones and/or Digital Coded Squelch (DCS) codes for access and control. It is the complete repeater control interface between the repeater transmitter and receiver. The microprocessor based design uses the latest state of the art non-volatile memory chips for data retention, and uses a proprietary digital algorithm for CTCSS tone detection. This eliminates adjacent tone falsing, provides for superior tone decoding response time and permits up to 157 subscriber capacity.

The TP-3200 Shared Repeater Tone Panel is field programmable, allowing the technician to program the individual repeater subscribers from a laptop computer, or by DTMF signaling from any base station. A five digit security code insures only authorized personnel may re-program the unit. The TP-3200 has built-in time and hit accumulators which record the activity of all CTCSS tones and DCS codes on the repeater channel. This data is stored in the non-volatile memory chips and can be recalled for observation at any time by a computer or DTMF signaling using the Communications Specialists Model DI-16 DATA INTERROGATOR.

The TP-3200 operates from 12 VDC obtained from the repeater power supply. Low power consumption is ideal for solar site applications. A wall transformer allows the TP-3200 to operate from 120 VAC. All RF connections are made through the DB-9 connector on the rear panel of the unit. The TP-3200 is enclosed in an RF tight metal enclosure, and is protected against static and lightning discharges that are common at mountain top sites.

## SECTION V

### OPERATION

The TP-3200 has two modes of operation. The primary mode of operation is the Normal Repeater Mode. The secondary mode of operation is the Programming Mode. The Normal Repeater Mode allows the TP-3200 to operate as a conventional shared repeater station. The TP-3200 will encode and decode 157 different CTCSS tones and DCS codes. If a repeater user is enabled, then the TP-3200 will key the transmitter, pass the repeat audio, and regenerate a new CTCSS tone for transmission. If a user is not enabled, the TP-3200 will decode the user, however, the transmitter will not key.

## **Front Panel Indicators**

Five front panel LEDs show the current operating status of the TP-3200. The five LEDs operate as follows:

**POWER LED-** Indicates that power is supplied to the unit.

**XMIT LED-** This RED LED indicates when the TP-3200 is keying the repeater transmitter.

**ENCode LED-** This LED indicates when the TP-3200 is regenerating a CTCSS encode tone or DCS code.

**CARrier LED-** This LED indicates when the TP-3200 is receiving a carrier signal from the repeater receiver.

**DECode LED-** This LED will illuminate when the TP-3200 decodes a CTCSS tone, DCS code, or DTMF digit.

## **Power up**

Upon application of the proper DC voltage to the TP-3200, the POWER LED will illuminate, and the ENCode LED will flash indicating proper operation. Upon power up, the TP-3200 goes through an automatic test of various parts of the circuit. If the TP-3200 finds any problems in the system, the ENCode LED will stay lit for an extended period of time. After the automatic test, the TP-3200 will operate in the normal repeater mode.

When the TP-3200 is first received from the factory, the non-volatile memories are initialized to a predetermined state. The memory contents can be modified to suit the particular requirements of the system. For further information see instructions in the Computer Programming and DTMF Programming section of this manual.

## **Remote Reset**

The TP-3200 is well protected against static and lightning damage that could upset the operation of the microprocessor. In the event the microprocessor is in an unusual state, it can be remotely reset by transmitting the DTMF digit '#' on the repeater input channel for at least 10 seconds. This will return the TP-3200 back to normal repeater operation.

## SECTION VI

### INSTALLATION

Installation of the Communications Specialists Model TP-3200 Shared Repeater Tone Panel should be done by qualified service personnel. If the TP-3200 is retrofitted to an existing repeater, remove or disable all repeat audio cards, timeout timers, and any other repeater control cards, since these will no longer be needed.

#### Jumper Options

The first step in the installation procedure is to configure the internal jumpers for your application. All modifications should be made with the POWER OFF to the TP-3200.

The TP-3200 contains five internal jumpers on the circuit board which provide flexibility for various installation requirements. The jumpers are installed at the factory for the most common application. Therefore, altering the jumper options will probably not be necessary for your installation. Please read over the jumper options to verify that they are correctly installed.

To access the internal jumpers, first remove the four screws on the bottom of the TP-3200 enclosure, then remove the rear panel, and slide the circuit board out.

#### **JP1- REPEAT AUDIO PROCESSING** **default- IN**

The audio signal from the repeater receiver discriminator is normally pre-emphasized. JP1 will de-emphasize the discriminator signal resulting in a flat audio response. This audio is then properly processed to be injected into a repeater transmitter. If the transmitted repeat audio has low high frequency response, or sounds bassy, then remove JP1 to increase the high frequency response of the circuit.

#### **JP2- TRANSMIT AUDIO GAIN** **default- IN**

If the input to the repeater transmitter is high impedance, then JP2 should be removed. For a low impedance transmitter, JP2 should be installed. If you cannot get enough repeat audio transmit deviation, install JP2.

#### **JP3- CTCSS/DCS OUTPUT RESPONSE** **default- IN**

If the repeater transmitter uses a phase modulator, then JP3 should be installed. If the repeater transmitter uses a direct FM modulator, then remove JP3. This can be tested by generating different CTCSS tones and checking to see if there is any significant output deviation variation as measured on a service monitor tuned to the repeater transmitter channel. If a significant variation exists, remove JP3. Please note that DCS codes **WILL NOT** operate with a phase modulated transmitter!

#### **JP4/JP5- PTT OUTPUT POLARITY** **default- JP4 OUT / JP5 IN**

This jumper controls the PTT voltage. If a ground is required to transmit, install JP5 and remove JP4. If +V is required for PTT, then remove JP5 and install JP4. DO NOT install both jumpers at the same time.

## RF Interface Connections

All TX and RX connections are made to the DB-9 RF Interface connector on the rear panel. All audio lines should use coaxial type shielded wire to reduce any RF interference. Shields should be terminated at both ends. The TP-3200 should be mounted as close as possible to the repeater transmitter-receiver. All audio lines should be kept as short as practical for the installation. See the Typical Installation diagram for wiring. The pin numbers on the rear panel RF Interface connector, J1, are arranged as follows:

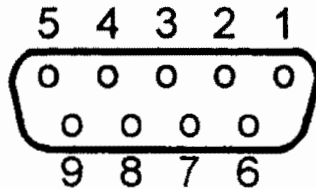

**J1-1 DC POWER INPUT-** Power input to the TP-3200 should be 12.6 VDC +/-20% regulated or unregulated obtained from the repeater power supply.

**J1-2 TRANSMITTER PTT OUTPUT-** This pin will provide PTT keying for the repeater transmitter by an internal relay.

**J1-3 RECEIVER DISCRIMINATOR-** Connect the repeater receiver discriminator to this pin. Please note that this connection should be made in the receiver before any de-emphasis circuit so the TP-3200 can process unfiltered audio.

**J1-4 COS INPUT-** This pin is used to control the length of the squelch tail that is heard when the mobile stops transmitting. Connect this pin to the receiver COS output. If this is not provided, connect this pin to the collector of the squelch switch transistor in the repeater receiver. The collector voltage should change from less than .4 volts, to at least 2.0 volts when squelched and unsquelched. The polarity is not important since it is programmable in the TP-3200.

**J1-5 TRANSMIT REPEAT AUDIO OUTPUT-** This pin can be connected to the microphone input or repeat audio input on the repeater transmitter.

**J1-6 GROUND-** Use this pin as the main power supply ground.

**J1-7,8 GROUND-** Connect the shield of all audio lines to these pins.

**J1-9 CTCSS OUTPUT-** This pin outputs the regenerated CTCSS tone or DCS code for transmission, and should be wired to the sub-audible tone input on the repeater transmitter. This connection is usually near the modulator circuit, and after any voice processing circuits in the repeater transmitter.

### LEVEL ADJUSTMENTS

Four level adjustments are located on the rear panel of the TP-3200. Adjustments are done by computer control using the Level Adjustments Menu and the On-Line Help. Please refer to the next section on Computer Programming.



## SECTION VII

### COMPUTER PROGRAMMING

Computer programming can be done by any computer or terminal with communications software and an RS-232 compatible serial port. Communications software such as PROCOMM is very common and popular. Communication parameters are 9600 baud, 8 data bits, 1 stop bit and no parity. Computer programming must be used to access all of the programmable features of the TP-3200. The front panel serial Programming Port is used for this purpose. **The TP-3200 can also be programmed remotely from the Programming Port by using an external 9600 baud modem.** Minimal instructions for programming are contained in this manual since 'On-Line Help' is provided in the TP-3200 programming software, and explains all of the unique and advanced features. Please note that if the TP-3200 is left in the Programming Mode with no activity for 5 minutes, the TP-3200 will automatically revert back to normal repeater operation.

To program the TP-3200 by a computer, connect an RS-232 cable from your computer's serial port to the DB-9 connector, J3, on the front panel of the TP-3200. After the connection is made, power up the TP-3200 and your computer, then activate your computer's communications software. **To access the TP-3200 computer programming mode, press the carriage return key.** The TP-3200 will respond with a request for password. Please note that the **DEFAULT PASSWORD = 12345**. Enter the five digit password and press carriage return. The Main Menu will then appear. Complete programming instructions and assistance for programming the TP-3200 are provided in the "On-Line Help" selections in each menu.

The pin numbers on the front panel Programming Port connector, J3, are arranged as follows:

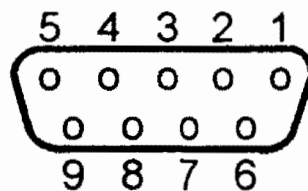

If you cannot communicate with the TP-3200 using your computer, check to make sure that the serial cable is wired properly. Make sure the cable you are using is a 'straight thru' cable. That is, pin 1 connects to pin 1, pin 2 connects to pin 2, and so on. Your computer's serial port should be configured as a standard DTE device. The TP-3200 is configured as a standard DCE device. If you are still having trouble, try using a 'null modem cable adapter'.

If for any reason you wish to reprogram the TP-3200 back to the factory default values, use the Global User Menu to initialize all user memory data, and then the System Parameters 2 Menu to load all default system parameters.

**COMMUNICATIONS SPECIALISTS**  
Shared Repeater Tone Panel TP-3200  
**MAIN MENU**      v1.1

- A>>      User Menu
- B>>      Global User Menu
- C>>      Air-Time Accumulators
- D>>      System Parameters 1
- E>>      System Parameters 2
- F>>      Level Adjustments
- O>>      On-line Help
- Q>>      Quit...Terminate Programming Session

Select LETTER >>

**MAIN MENU ONLINE HELP**

**USER MENU-** This menu is used for setting the operational parameters of each individual CTCSS or DCS repeater user. All CTCSS tones and DCS codes programmed in the tone panel can be associated with a user group on the repeater. The CTCSS tones and DCS codes are referred to as "users".

**GLOBAL USER MENU-** This menu will set the operational parameters of all CTCSS and DCS repeater users on a global basis. The Global User Menu is normally used during initial setup of the repeater panel to expedite user programming by the system operator. For example, if you want the Busy Channel Lockout feature to be disabled for ALL USERS, it is easier to use this menu to globally change the parameter for all users at once, than to disable the feature for each individual user by using the User Menu. See the User Menu on-line help for information on most of the items in this menu.

**AIR-TIME ACCUMULATORS-** This menu displays the air time and hit accumulators for repeater statistics and analysis. User prepay airtime is also programmed from this menu.

**SYSTEM PARAMETERS 1/2-** These menus set the primary operational characteristics and features of the repeater system. All of these parameters operate on a global basis, and will effect all repeater users.

**LEVEL ADJUSTMENTS-** This menu is used for first time repeater setup of the transmit deviation and other level settings.

**QUIT-** This menu item will exit the programming mode, and return the repeater panel to normal repeater operation.

## USER MENU

A >>	Select User	→	254.1
B >>	User Status		Off
C >>	Reserve Tone		Off
D >>	Busy Channel Lockout		On
E >>	Hold TX Encode Tone		On
F >>	Courtesy Tone		Off
G >>	Air Time Hog Penalty		Off
H >>	Prepaid Airtime User		Off
I >>	TX Carrier Hold Time		3.0 seconds
J >>	Cross Tone/DCS Code		
K >>	User CW Callsign		
L >>	View CTCSS User Table		
M >>	View DCS User Table		
O >>	On-line Help		
Q >>	Quit... Return to Main Menu		

Select LETTER >>

### USER MENU ONLINE HELP

**SELECT USER-** Use this menu item for displaying the parameters of a specific user. Enter a CTCSS tone or DCS code. If you are not sure about the correct tone or code to enter, view the user tables for a listing of all valid tones and codes.

**USER STATUS-** This identifies the status of a user as ON or OFF. If a user is ON, the user will have access to the repeater and the repeater TX will key. If the user is OFF the user will be denied access to the repeater, but the user will still decode. All users on your repeater must be set to the ON condition.

**RESERVE TONE-** A user set for reserve tone status will key the repeater, but repeat audio will not be passed. A low frequency beep tone is generated when the user keys. A user set for reserve tone must also have the USER STATUS set to ON.

**BUSY CHANNEL LOCKOUT-** Once the repeater is in use by one of the repeater users, any other repeater users on a different tone, will be locked out from accessing the repeater as long as the repeater is transmitting.

**HOLD TX ENCODE TONE-** If this feature is ON, the transmitted encode tone will continue until the repeater stops transmitting. If this feature is OFF, the repeater encode tone will drop as soon as the user stops transmitting.

**COURTESY TONE-** This feature generates a BEEP tone after a user stops transmitting.

**HOG PENALTY-** This menu item will activate the hog penalty feature for this user. The Hog Penalty feature limits the amount of continuous time a user may use the repeater.

**PREPAID AIRTIME-** This menu item will only allow a user to operate on the repeater for the amount of time programmed in the Users Pre-paid Airtime Accumulator. When this feature is activated, the Users Pre-paid Airtime Accumulator must also be programmed in the Air-Time Accumulator Menu.

**TX CARRIER HOLD TIME-** After a repeater user unkeys, the repeater will continue to transmit for this programmed duration of time.

**CROSS TONE/DCS CODE-** This is the CTCSS tone or DCS code that is generated by the repeater for a particular user. If no entry is entered, the tone or code generated by the repeater is the same as the decoded tone or code.

**USER CW CALLSIGN-** A Morse code callsign may be generated for each user on the repeater. The callsign is transmitted after the end of the users first transmission. Up to 8 characters may be entered for the callsign.

**VIEW USER TABLES-** These items allow you to view the status of all tones and codes programmed in the tone panel. Press any key to stop the listing at any time.

## **GLOBAL USER MENU**

- A>> User Status
- B >> Reserve Tone
- C >> Busy Channel Lockout
- D >> Hold TX Encode Tone
- E >> Courtesy Tone
- F >> Air Time Hog Penalty
- G >> Prepaid Airtime User
- H >> Global TX Carrier Hold Time
- I >> View CTCSS User Table
- J >> View DCS User Table
- K >> Initialize User Memory
- O >> On-line Help
- Q >> Quit...Return to Main Menu

Select LETTER >>

### **GLOBAL USER MENU ONLINE HELP**

See the User Menu for details on most of these menu items.

**INITIALIZE USER MEMORY-** This menu item will re-program the entire user memory to the factory default condition. Any data that you have programmed will be lost. The tone panel comes from the factory in this condition.

## **AIR-TIME ACCUMULATORS**

- A>> Display 24 Hour Loading Graph
- B>> Display User Time Accumulator Records
- C>> Display User Hit Accumulator Records
- D>> Display Total Transmit Time
- E>> Load User Pre-paid Airtime
- F>> Clear Time and Hit Accumulators
- O>> On-line Help
- Q>> Quit...Return to Main Menu

Select LETTER >>

### **AIR-TIME ACCUMULATOR ONLINE HELP**

**24 HOUR LOADING GRAPH-** This graph shows the repeater channel loading percentage on an hourly basis over the last 24 hours. For example, a 10% loading for hour #4 (4 hours ago) indicates the repeater was active for 6 minutes (10% of 60 minutes).

**TIME AND HIT ACCUMULATOR RECORDS-** These menu items will display the time and hit records for all CTCSS tones and DCS codes. A graphical display also indicates loading between different users.

**TOTAL TX TIME-** This shows the total amount of time the repeater transmitter has been on the air. This is not the same as the accumulation of all user time records.

**LOAD PRE-PAID AIRTIME-** This menu item is used for entering the Pre-paid Airtime for each user. The amount of airtime is programmed into the users time accumulator, and the accumulator is reduced to zero as the airtime is used. Warning beeps are generated when the pre-paid airtime is less than 5 minutes. When the a users airtime is reduced to zero, the user is placed in the reserve tone mode until more airtime is programmed. Be sure to also enable the pre-pay user selection for a user in the User Menu. Press <CR> at Users Tone/Code prompt to exit.

**CLEAR ACCUMULATORS-** This menu item will reset and clear to zero all time and hit accumulators.

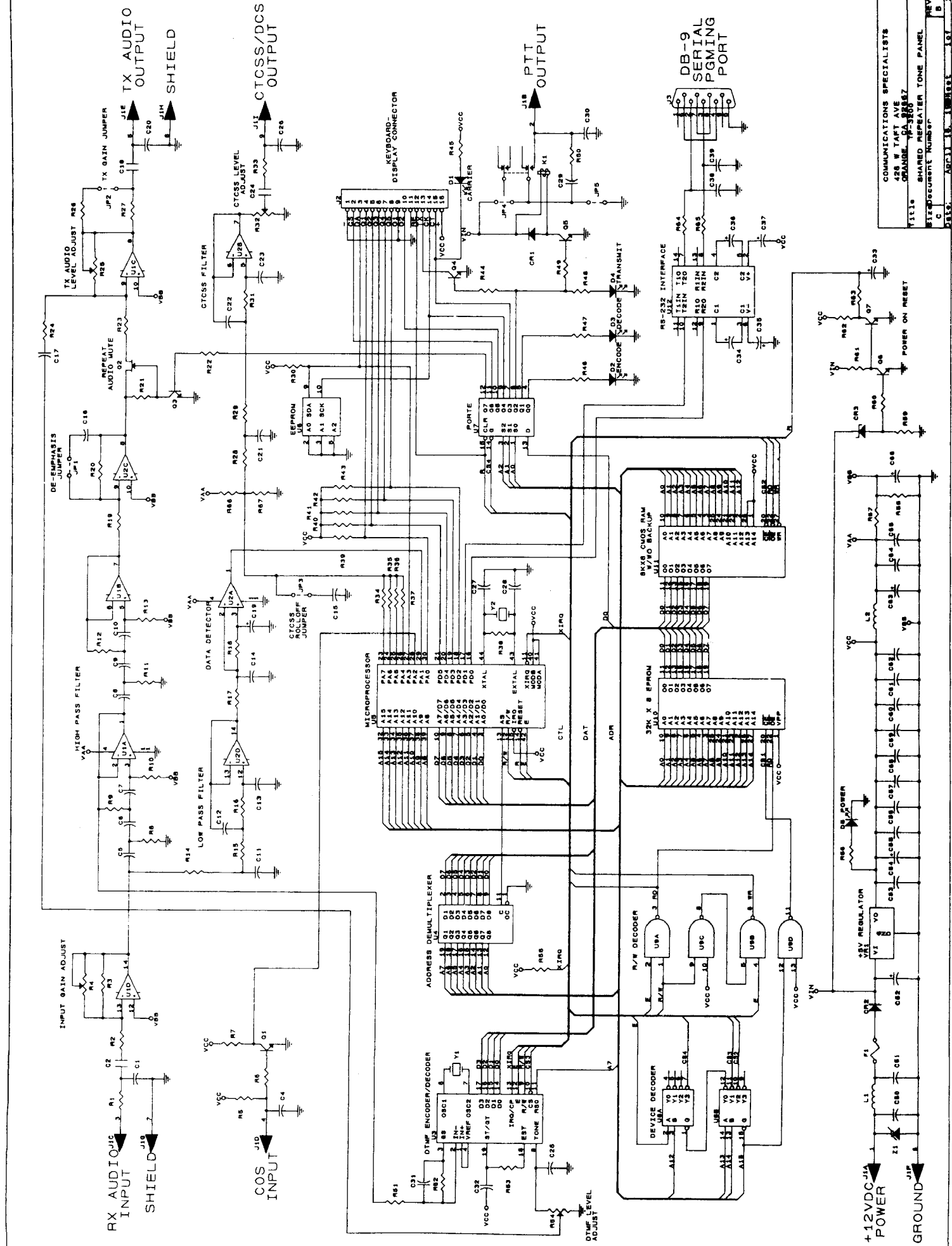

COMMUNICATIONS SPECIALISTS  
 424 W TAFT AVE  
 ORANGE, CA 92667  
 FILE # SHARED REPEATER TONE PANEL  
 DOCUMENT NUMBER  
 REV. C  
 APR 11 1993

## SYSTEM PARAMETERS 1

A >>	Transmit Time-Out-Timer	0180 seconds
B >>	Change Password	12345
C >>	System CW Station ID	
D >>	System CW ID Interval	0900 seconds
E >>	User CWID Interval	0180 seconds
F >>	Program Signon Message	SIGN-ON MESSAGE
G >>	Anti-Kerchunk Time	0.0 seconds
H >>	Hog Time Limit	0300 seconds
I >>	Hog Idle Time	0010 seconds
J >>	Hog Penalty Time	0300 seconds
O >>	On-line Help	
Q >>	Quit Return to Main Menu	

Select LETTER >>

### SYSTEM PARAMETERS 1 ONLINE HELP

**TRANSMIT TIME OUT TIMER-** Once the repeater transmitter is keyed up by a user, it will automatically unkey if a user's signal remains on the repeater input channel for a duration that exceeds the time programmed in this timer. Warning beeps are generated 20 seconds prior to a user transmit time out.

**CHANGE PASSWORD-** The 5 digit number used to access the programming mode may be changed with this menu item. **DO NOT LOSE THE PASSWORD** as access to the repeater panel programming will be impossible. If the **PASSWORD** is lost, please contact the factory for assistance.

**SYSTEM CW STATION ID-** This menu item will program the Morse characters that can be used for a main system station ID. Up to 8 characters may be entered for the callsign. The callsign is transmitted at 25 WPM.

**SYSTEM CW ID INTERVAL-** This interval determines how often the repeater will generate a Morse station ID for the system. The ID is only sent if the time interval has expired, and the repeater transmitter is active.

**USER CW ID INTERVAL-** This interval determines how often the repeater will generate a Morse station ID for an individual user. The ID is only sent when a user is active on the repeater, and if the time interval has expired.

**SIGN-ON MESSAGE-** When the tone panel requests the programming access password, a "sign-on message" is displayed at the top of the screen. This message is used to identify the repeater station by a name, frequency pair or other criteria.

**ANTI-KERCHUNK TIME-** If a mobile keys for a duration that is shorter than the programmed anti-kerchunk time, the repeater transmitter will not stay keyed for the duration of the users TX Carrier Delay Time, but will unkey immediately.

**HOG TIME LIMIT-** This is the maximum time allowed for a single user to tie up the repeater in a single communication exchange. Warning beeps are generated 20 seconds prior to a hog time out.

HOG IDLE TIME- This is the amount of time required for a user to be inactive on the repeater before the Hog Time Limit is reset. HOG PENALTY TIME- If a user exceeds the Hog Time Limit, the user will be placed in the Reserve Tone mode for the duration of the time programmed in the Hog Penalty Time.

## SYSTEM PARAMETERS 2

A>>	Real-Time Display	On
B>>	COS Signal Polarity	Normal
C>>	DCS Encode Polarity	Normal
D>>	DCS Decode Polarity	Normal
E>>	Stuck Mic Identification	Off
F>>	User DTMF Regeneration	Off
G>>	Carrier Only Operation	Off
H>>	Load Default Parameters	
O>>	On-line Help	
Q>>	Quit...Return to Main Menu	

Select LETTER >>

### SYSTEM PARAMETERS 2 ONLINE HELP

**REAL-TIME DISPLAY-** The Real Time Display will show decoded CTCSS tones, DCS codes and DTMF tones on the computer serial port as they are decoded by the repeater panel.

**COS POLARITY-** This menu item sets the logic level that indicates a receive carrier is present. Normally, a high level voltage indicates a carrier is present, while a low level voltage, or ground indicates no signal is present. Set this menu item so that the CARRIER LED illuminates when a carrier signal is present at the receiver.

**DCS ENCODE/DECODE POLARITY-** This menu item will invert the data polarity of the encoded and decoded DCS signal. The DCS data polarity is normally determined by trial and error in your repeater system.

**STUCK MIC ID-** If a users transmission exceeds the duration of the TX Time Out Timer, this feature will transmit the users CTCSS or DCS code using DTMF just before the transmitter unkeys.

**USER DTMF REGENERATION-** DTMF characters transmitted by users that are received can be regenerated to provide a lower distortion re-transmission.

**CARRIER ONLY OPERATION-** This feature allows the repeater to operate in a conventional carrier only repeater mode. Only carrier is required to access and use the repeater.

**LOAD DEFAULT PARAMETERS-** This menu item will reset all System Parameters to the factory default values. Any parameters that you have programmed will be lost. The default parameters are set to the most commonly used values. Use these as a reference.



## LEVEL ADJUSTMENTS

A>>	Key Transmitter	
B>>	Unkey Transmitter	
C>>	Set RX Input Gain Level	[R4]
D>>	Set TX Voice Modulation	[R25]
E>>	Set DTMF Encode Modulation	[R54]
F>>	Set CTCSS Tone Modulation	[R32]
G>>	Test DTMF decoder	
O>>	On-line Help	
Q>>	Quit...Return to Main Menu	

Select LETTER >>

### LEVEL ADJUSTMENTS ONLINE HELP

**KEY TRANSMITTER** - This menu item will close the PTT Relay and key the transmitter.

**UNKEY TRANSMITTER** - This menu item will unkey the transmitter.

**SET RX INPUT GAIN** - This menu item is used for setting the proper RX signal level to the repeater panel. Set a service monitor to generate a full quieting signal on the repeater input frequency. Then modulate the carrier with a CTCSS tone of 100.0 hz, and a deviation level of only 100 hz. Now adjust R4 from the fully counterclockwise position until the DECode LED illuminates on the front panel. Always set this adjustment first.

**SET TX VOICE MOD** - This item will key the transmitter, and open the RX to TX audio path. Generate a modulated signal on the repeater input with the appropriate deviation, and then monitor the TX output channel with a deviation scope and adjust R25 for the proper deviation for your system. Always set this adjustment after the RX Input Gain.

**SET DTMF ENCODE MOD** - This item will key the transmitter, and generate a DTMF digit on the TX output channel. Monitor the TX output channel with a deviation scope and adjust R54 for the maximum undistorted deviation level for your system. Always set this adjustment after the TX Voice Mod.

**SET CTCSS MOD** - This item will key the transmitter, and generate a CTCSS or DCS code on the TX output channel. First, enter the tone/code you wish to generate, then monitor the TX output channel with a deviation scope and adjust R32 for the subaudible deviation level for your system (.5 to 1.0 khz).

**TEST DTMF DECODER** - This menu item will display DTMF digits as they are received on the repeater input channel.

## SECTION X

### DTMF PROGRAMMING

Programming the TP-3200 by DTMF is accomplished by a control station on the repeater channel equipped with a 12 or 16 button DTMF encoder, or the Communications Specialists Model DI-16 DATA INTERROGATOR. A standard DTMF encoder will allow the radio shop to control many programmable features in the TP-3200 that must be altered from time to time from a remote location. In order to recall data from the TP-3200, the DI-16 DATA INTERROGATOR or a DTMF display decoder must also be used.

The first step in programming the TP-3200 is to enter the Programming Access Code by DTMF signaling on the repeater input channel. To enter the programming mode, transmit the five digit programming access code followed by the '#' key on the repeater channel. Please note that the DEFAULT PROGRAMMING ACCESS CODE = 12345. As soon as the proper code is received, the TP-3200 will key up and transmit a double beep. Signals received by the TP-3200 will not be repeated while in the programming mode.

When you have finished programming, revert the TP-3200 back to normal repeater operation by pressing the '#' key, and hold it down for at least 10 seconds. This will reset the TP-3200, and it will revert to normal repeater operation. If the TP-3200 is left in the Programming Mode with no activity for 5 minutes, the TP-3200 will automatically revert back to normal repeater operation.

The following table summarizes the DTMF programming commands:

#### PROGRAMMING

CODE	FUNCTION	DEFAULT
10#	User Enable-Disable Status	OFF
11#	User Enable-Disable Reserve Tone	OFF
12#	User Enable-Disable Busy Channel Lockout	ON
13#	User Enable-Disable Hold TX Encode Tone	ON
14#	User Enable-Disable Courtesy Tone	OFF
15#	User Enable-Disable Hog Penalty	OFF
16#	User Enable-Disable Prepay Airtime	OFF
17#	User TX Carrier Delay Time	3.0 sec
18#	User Cross Tone Encode	NONE
19#	User Station ID	NONE
20#	Recall User Time Accumulator	
21#	Recall User Hit Accumulator	
22#	Recall the Total TX time	
23#	Load User Prepay Airtime	
24#	Reset and Clear Time and Hit Accumulators	
25#	High Speed Time and Hit Counter Recall	

After a parameter is programmed, the TP-3200 will key up and transmit a high frequency double beep. If an error is detected while programming the TP-3200 will key up and transmit three low frequency beeps.

Program codes 10 thru 16 use the following format:

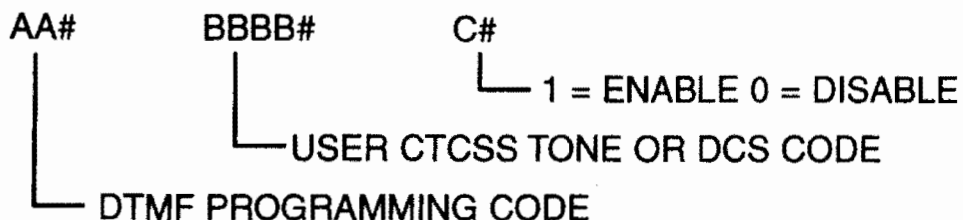

These programming codes are derived from the computer programming User Menu. A two digit DTMF programming code is used to select the parameter to program. A user can be any CTCSS tone or DCS code. When entering a user tone frequency, such as 100.0 hz., use the '\*' key as the decimal point followed by the '#' key (100\*0#). When entering a user DCS code, simply use the three digit DCS code number followed by the '#' key (023#). The parameter selected is then enabled or disabled. Enter a '1#' to enable or a '0#' to disable the feature. When the last key is pressed, the TP-3200 will key up and transmit two beep tones to acknowledge the programming sequence.

EXAMPLE: A new user using 203.5 Hz is placed on the repeater. This subscriber can use the repeater by having the CTCSS tone, 203.5 Hz enabled using the programming code '10#'. To enable this user, transmit the following DTMF tones:

10# 203\*5# 1#

EXAMPLE: To disable a DCS user 023, transmit the following DTMF tones:

10# 023# 0#

### **PROGRAMMING CODE 17#- USER TRANSMIT CARRIER-DELAY TIME**

This programming code sets a users TX carrier-delay timer in 0.1 second steps, ranging from 0.0 seconds to 9.9 seconds. This delay is the amount of time that the repeater transmitter will stay on the air after the input carrier disappears. A users TX carrier-delay time is programmed by entering the programming code '17#', followed by the users CTCSS tone or DCS code followed by the '#' key, and then the time, in .1 second steps, for the TX carrier delay. Terminate the time with the '#' key.

EXAMPLE: To set the TX carrier delay for user 67.0 hz to 2.5 seconds, transmit the following DTMF tones: 17# 67\*0# 2\*5#

## PROGRAMMING CODE 18#- USER CROSS TONE ENCODE

This parameter tells the TP-3200 to regenerate a different CTCSS tone or DCS code than the one currently being received on the input channel of the repeater. A users cross tone is programmed by entering the programming code '18#', followed by the users CTCSS tone or DCS code followed by the '#' key, and then the cross CTCSS tone or DCS code to encode. Terminate with the '#' key.

EXAMPLE: To set user 203.5 hz for a cross tone of 100.0 hz, transmit the following DTMF tones: 18# 203\*5# 100\*0#

EXAMPLE: To cancel a cross tone for user 203.5, transmit the following DTMF tones: 18# 203\*5# #

## PROGRAMMING CODE 19#- USER STATION ID

This programming code programs in the Morse code station call sign for a user. A maximum of eight characters may be programmed. The call sign is sent at 25 words per minute after the end of a users first transmission, and again at the users station ID programmed interval. To program a users station call sign, dial the programming code, '19#', followed by the users CTCSS tone or DCS code followed by the '#' key, and then dial the two digit number to the right of the letters or numbers that you wish to program for that user. Continue to program additional characters in the same manner. Follow each number code with the '#' key. At the completion of the call sign entry, fill up the remaining locations with '00#' until all eight characters have been entered.

N/L	#	N/L	#	N/L	#
0	48	C	67	O	79
1	49	D	68	P	80
2	50	E	69	Q	81
3	51	F	70	R	82
4	52	G	71	S	83
5	53	H	72	T	84
6	54	I	73	U	85
7	55	J	74	V	86
8	56	K	75	W	87
9	57	L	76	X	88
A	65	M	77	Y	89
B	66	N	78	Z	90

EXAMPLE: To program in the station call sign of 'KMG365' for user 250.3 hz, dial the following number sequence:

19# 250\*3# 75# 77# 71# 51# 54# 53# 00# 00#

Notice that all eight characters must be programmed. When the TP-3200 sends the identification, the following sequence will be transmitted: 'KMG365'  
To clear out a call sign for user 250.3 hz, enter the following sequence:

19# 250\*3# 00# 00# 00# 00# 00# 00# 00# 00#

### **PROGRAMMING CODE 20#- RECALLING USER TIME ACCUMULATOR DATA**

This programming code will recall the time accumulator data for any CTCSS or DCS user. To recall time data for a user, enter in the programming code '20#', followed by the users CTCSS tone or DCS code that you want to recall, followed by the '#' key.

EXAMPLE: To recall data for DCS user 114, transmit  
the following DTMF tones: 20# 114#

The TP-3200 will transmit the total accumulated time for the user in minutes using DTMF. This data can be displayed and printed when the DI-16 DATA INTERROGATOR is used, or a DTMF display decoder may be used.

### **PROGRAMMING CODE 21#- RECALLING USER HIT ACCUMULATOR DATA**

This programming code will recall the hit accumulator data for any CTCSS or DCS user. To recall hit data for a user, enter in the programming code '21#', followed by the users CTCSS tone or DCS code that you want to recall, followed by the '#' key. The TP-3200 will transmit the total accumulated hits for the user using DTMF. This data will then be displayed and printed on the DI-16 DATA INTERROGATOR, or a DTMF display decoder.

### **PROGRAMMING CODE 22#- RECALLING THE TOTAL TX TIME**

This programming code will display the total accumulated time for the repeater transmitter. Please note that the time accumulated for all users will not add up to the same number as the time for the repeater transmitter since the individual time counters do not include the carrier delay time duration. This data is useful for doing loading studies on different repeaters, and calculating the duty cycle of different repeaters. This data can be recalled by entering in the programming code '22#', The TP-3200 will transmit the total accumulated time using DTMF. This data will then be displayed and printed on the DI-16 DATA INTERROGATOR, or a DTMF display decoder.

### **PROGRAMMING CODE 23#- LOAD USERS PREPAY AIRTIME**

This programming code will program a users prepay airtime. To program a users prepay airtime, enter the programming code '23#', followed by the users CTCSS tone or DCS code you wish to program, followed by the '#' key, and then the amount of prepay airtime, in minutes, to program for the user. Maximum time is 9999 minutes. Follow this by the '#' key. Also, make sure the users prepay airtime feature is enabled with programming code '16#'.

EXAMPLE: To program the user 123.0 hz for 1200 minutes of airtime  
(20 hours), transmit the following DTMF tones: 23# 123\*0# 1200#

### **PROGRAMMING CODE 24#- CLEAR TIME AND HIT ACCUMULATORS**

This programming code will clear and reset to zero, all time and hit accumulators. All previous data in the counters will be erased.

### **PROGRAMMING CODE 25#- HIGH SPEED TIME AND HIT RECALL**

This programming code is used for high speed recall of time and hit accumulation counter data for all users. This can be used with the DI-16 DATA INTERROGATOR for printing out all counter data on the Printer Option. When the programming code, '25#' is entered, the TP-3200 will begin to transmit the time and hit counter data for all users.

## SECTION XI

### **DATA INTERROGATION**

The TP-3200 has the capability to transfer data to and from a control station on the repeater channel using DTMF signaling. Instructions can be sent to the TP-3200, via the input channel of the repeater, in order to recall data which is stored in the nonvolatile memory chips. This data comes back to the control station, by DTMF, on the output channel of the repeater station. By using the DI-16, data can be recalled from the TP-3200 regarding time and hit accumulator data. This data is very useful for locating new CTCSS tones for new repeater subscribers, since the TP-3200 records all the activity on the channel. This data can also be used for subscriber time billing.

In order to receive the data from the TP-3200, the Communications Specialists Model DI-16 DATA INTERROGATOR can be used. The DI-16 is a microprocessor controlled DTMF encoder and DTMF decoder in a desk top unit. Optionally, any DTMF display decoder could be used in conjunction with a 12 or 16 button DTMF encoder. The DI-16 has a serial printer output which allows the recalled data to be listed out on the DI-16 Printer Option.

Data is recalled from the TP-3200 by first entering in the 5 digit Security Code from a control station on the repeater channel that is equipped with a DTMF encoder. Then, enter in the proper programming code from the Programming Section of this manual for recalling data. Within a few seconds after the last keystroke is entered, the TP-3200 will start sending the DTMF data down the repeater output channel. This information will be shown in the LED display of the DTMF display decoder. Please refer to the Programming Section of the DI-16 instructions for more detailed information on recalling data from the TP-3200. To terminate the programming session, and to return to normal repeater operation, press the '#' key, and hold it for at least 10 seconds.

The TP-3200 uses a monolithic decoder for receiving DTMF signaling. This chip is designed to be used on RF channels, and therefore has good sensitivity to noise, and twist. However, care must be observed when sending DTMF signals to the TP-3200. If the DTMF decoding seems unreliable, then try changing the deviation level of the DTMF tones either up or down. The TP-3200 should also be receiving a signal which is as full quieting as possible.

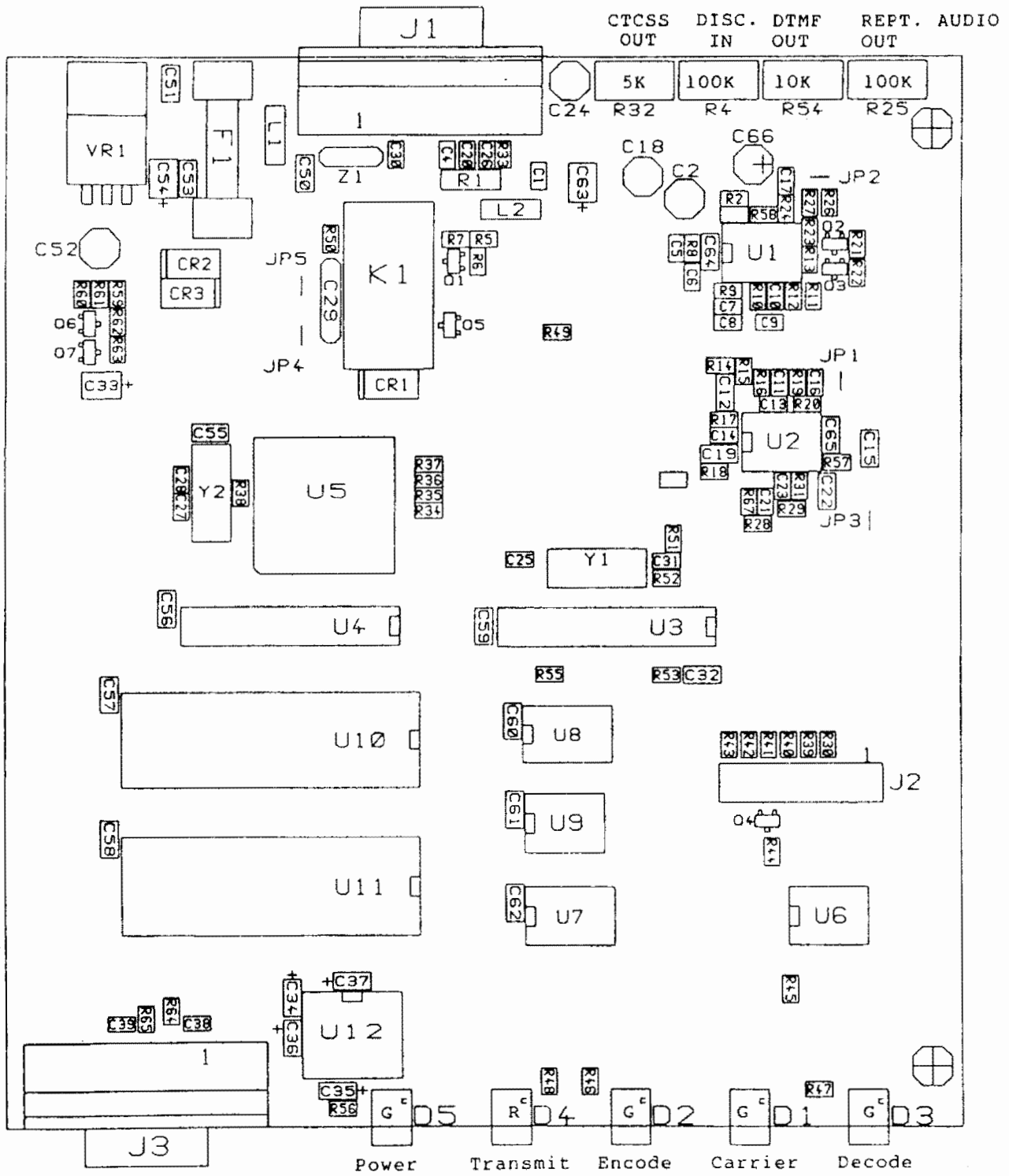

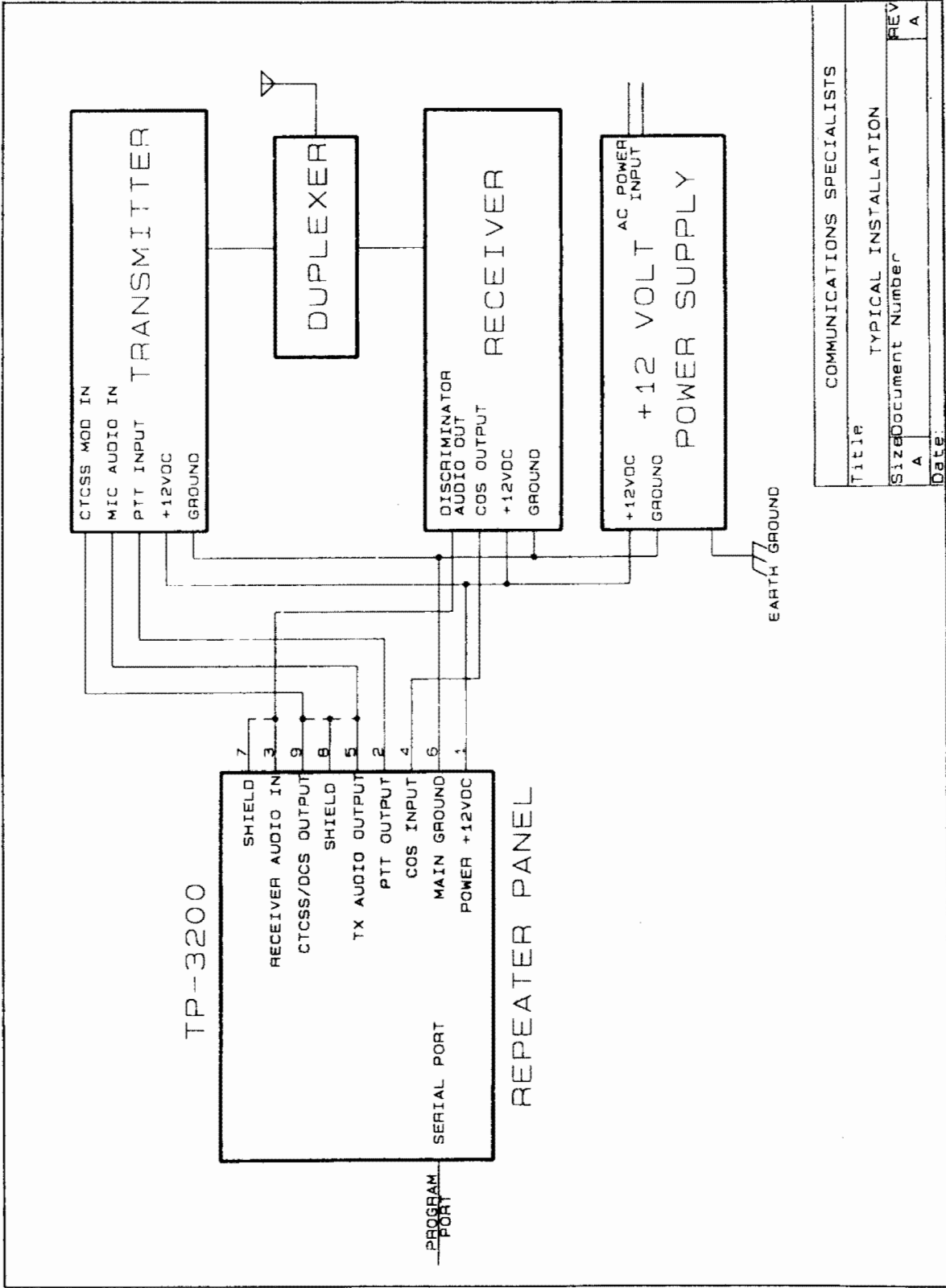

Title		COMMUNICATIONS SPECIALISTS
Size		TYPICAL INSTALLATION
Document Number	REV	A
Date:		



# PARTS LIST

DESIGNATION	CSI P/N	DESCRIPTION	PRICE
U5	51-6811	MC68HC11DOFN CMOS Microprocessor	14.68 ea
U10	51-2256	TMS27C256-20JL 32Kx8 CMOS EPROM Programmed	25.00 ea
U11	51-6264	HM6264ALP-15 8Kx8 CMOS RAM	10.00 ea
U3	51-8880	MT8880CE DTMF Transceiver	9.84 ea
U12	51-0232	MAX232CWE RS-232 Interface	6.72 ea
U7	51-4259	MC74HC259D Addressable Latch	1.60 ea
U4	51-4573	MC74HC573N Transparent Latch	2.08 ea
U8	51-4139	MC74HC139AD Two of Four Decoder	.86 ea
U9	51-7400	MC74HC00D Quad Nand Gate	1.28 ea
U1,U2	51-3240	LM324D Quad Op-Amp	1.08 ea
U6	51-1614	X24C16S14 16K CMOS EEPROM	14.44 ea
VR-1	48-4011	MC7805CT 5.0v TO-220 Regulator	2.19 ea
CR1,CR2	48-4002	1N4002 Silicon Diode	.16 ea
CR3	48-5236	1N5236B 7.5v Zener Diode	.24 ea
D4	48-5381	Red LED with Mounting	1.24 ea
D1,D2,D3,D5	48-5385	Green LED with Mounting	1.24 ea
F1	65-1009	.5A 5x20MM Fast Blow Fuse	.16 ea
K1	80-1003	LM44D00 DPDT 12vdc Relay, 2A Contacts	5.10 ea
L1,L2	25-1014	43LS104 100uh RF Choke	.57 ea
Q1,Q3,Q4,Q5,Q6,Q7	48-4401	B MMBT4401 NPN Silicon Transistor (2x)	.30 ea
Q2	48-2010	SST201 N-Channel FET (P1AD)	1.40 ea
Y1	48-0358	3.579Mhz HC-49US Crystal	1.68 ea
Y2	48-8000	8.000Mhz HC-49US Crystal	2.20 ea
Z1	06-5270	ERZ-C05DK270 5MM Surge Absorber	.68 ea
C66	23-1012	100uf-25v Radial Alum. Elect. Capacitor	.21 ea
C2,C18,C24,C52	23-1013	10uf-25v Bipolar Alum. Elect. Capacitor	.26 ea
C33,C54,C63	19-1063	10uf-16v Tant. 1311 Chip Capacitor	.84 ea
C34 - C37	19-1056	1uf-16V Tant. 1206 Chip Capacitor	.78 ea
C50,C51	22-2246	.22uf-50v 1206 Z5U Chip Capacitor	.20 ea
C12,C5,C22,C32,C53,C55,-C62,C64,C65,C19	22-1040	.1uf-50v 1206 X7R Chip Capacitor	.20 ea
C14	22-1040A	.1uf-25v 0805 X7R Chip Capacitor	.20 ea
C1,C11,C16,C17,C21,C25	22-1030	.01uf-50v 0805 X7R Chip Capacitor	.20 ea
C5 - C10	22-4720	4700pf-50v 0805 X7R Chip Capacitor	.20 ea
C29	24-1020	1000pf-1Kv Ceramic Disc Capacitor	.24 ea
C4,C26,C30,C31,C38,C39	22 1026	1000pf-50v 0805 X7R Chip Capacitor	.20 ea
C13,C20,C23	22-1510	150pf-50v 0805 NPO Chip Capacitor	.20 ea
C27,C28	22-2706	27pf-50v 0805 NPO Chip Capacitor	.20 ea
R1	06-5124	5.1K 1/4w Carbon Film Resistor	.10 ea
R63,R64,R65	06-1016	100 OHM 0805 Chip Resistor	.10 ea
R45,R46,R47,R48	06-2416	240 OHM 0805 Chip Resistor	.10 ea
R56	06-2716	270 OHM 0805 Chip Resistor	.10 ea
R50	06-4716	470 OHM 0805 Chip Resistor	.10 ea
R26,R33	06-2226	2.2K 0805 Chip Resistor	.10 ea
R58	06-4326	4.3K 0805 Chip Resistor	.10 ea
R22,R30,R44,R49,R55,R59,R60	06-4726	4.7K 0805 Chip Resistor	.10 ea
R17	06-5626	5.6K 0805 Chip Resistor	.10 ea
R57,R23	06-6826	6.8K 0805 Chip Resistor	.10 ea
R61	06-1036	10K 0805 Chip Resistor	.10 ea

## PARTS LIST

DESIGNATION	CSI P/N	DESCRIPTION	PRICE
R9,R12	06-2736	27K 0805 Chip Resistor	.10 ea
R34	06-3036	30K 0805 Chip Resistor	.10 ea
R2,R6,R7,R39 - R43	06-3336	33K 0805 Chip Resistor	.10 ea
R20,R67	06-3936	39K 0805 Chip Resistor	.10 ea
R5,R21,R62	06-4736	47K 0805 Chip Resistor	.10 ea
R35	06-6236	62K 0805 Chip Resistor	.10 ea
R8,R11,R24	06-7536	75K 0805 Chip Resistor	.10 ea
R27,R19	06-1046	100K 0805 Chip Resistor	.10 ea
R36	06-1246	120K 0805 Chip Resistor	.10 ea
R51,R52	06-1546	150K 0805 Chip Resistor	.10 ea
R28,R29,R31	06-1646	160K 0805 Chip Resistor	.10 ea
R14,R15,R16	06-1846	180K 0805 Chip Resistor	.10 ea
R37	06-2446	240K 0805 Chip Resistor	.10 ea
R53	06-3346	330K 0805 Chip Resistor	.10 ea
R10,R13	06-5146	510K 0805 Chip Resistor	.10 ea
R18	06-7546	750K 0805 Chip Resistor	.10 ea
R38	06-2756	2.7 MEG 0805 Chip Resistor	.10 ea
R32	18-3502	5K 3/8" Square Potentiometer	2.40 ea
R54	18-0103	10K 3/8" Square Potentiometer	2.40 ea
R4,R25	18-0104	100K 3/8" Square Potentiometer	2.40 ea
J3	09-8722	DB9 PCB Female EMI Screw-In Connector	6.92 ea
J1	09-8723	DB9 PCB Female EMI Snap-In Connector	7.12 ea
J2	09-8726	16 Pin Dual Row Male Header	.88 ea
JP1,2,3,5	30-7035	Factory Installed Jumpers	.03 ea
	09-8528	28 Pin Socket for U10	.50 ea
	09-8520	20 Pin Sockets for U3 and U4	.35 ea
	09-1213	SMARTSOCKET with Battery for U11	34.20 ea
	65-1008	5MM PCB Fuse Clips	.18 ea
	43-1008	Crystal Spacers	.16 ea
	84-3200	TP-3200 Printed Circuit Board	19.52 ea
	15-3201	Single Unit Mounting Rack	19.68 ea
	15-3203	Triple Unit Mounting Rack	20.40 ea
	15-3204	Desk-Top Front Panel	11.61 ea
	15-3202	Rear Panel	11.61 ea
	15-3200	Enclosure Extrusion	15.72 ea
	43-1020	.25" 4-40 Spacer	.38 ea
	43-1021	Hex Threaded Posts (Jackscrews)	.36 ea
	03-1002	4-40x114 Phillips Pan Head Screw	.05 ea
	03-1027	4-40 Small Nut	.05 ea
	04-1000	#4 Internal Tooth Lockwasher	.05 ea
	03-1011	4-40x3/16 Phillips Pan Head Screw	.05 ea
	03-1008	4-40x3/8 Phillips Pan Head Screw	.05 ea
	03-1026	#4x1/2 Oval Head Self Tapping Screw	.10 ea
	75-1001	Rubber Feet	.05 ea
	68-3200	Instruction Manual	1.00 ea
	09-8724	DB9 Male Connector (Loose)	1.40 ea
	09-8725	DB9 Plastic Hood (Loose)	1.60 ea
	01-1046	Start-up Kit (see inside front cover)	15.95 ea

## **WARRANTY**

The TP-3200 is warranted to be free from defects for a period of five (5) years from the date of purchase. Just return the unit to the factory and we will repair or replace it (at our option) at no charge.



**COMMUNICATIONS SPECIALISTS, INC.**

426 WEST TAFT AVENUE • ORANGE, CA 92865-4296  
(714) 998-3021 • FAX (714) 974-3420

Entire U.S.A. (800) 854-0547 • FAX (800) 850-0547

<http://www.com-spec.com>