

SS-32 INSTRUCTION SHEET

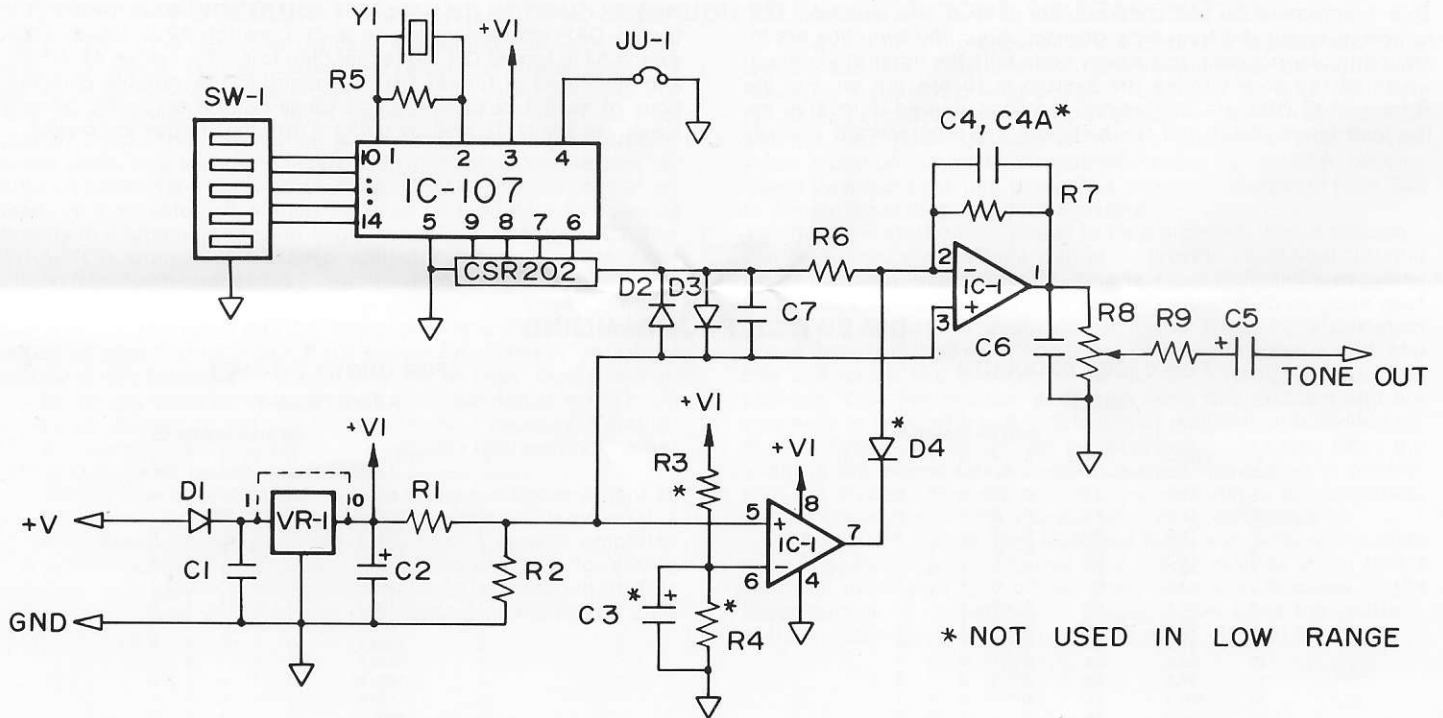

Communications Specialists
 426 W. Taft Ave., Orange, CA 92667
 (714) 998-3021 (California) / (800) 854-0547



SS-32 ENCODER PARTS LIST

R1 -	10K	1/8 watt	5%	resistor, carbon film	\$.31 ea.
R2 -	9.1K	"	"	" " "	.31 ea.
R3 -	470K	"	"	" " "	.31 ea.
*R4 -	1Meg	"	"	" " "	.31 ea.
R5 -	10Meg	"	"	" " comp.	.31 ea.
R6 -	15K	"	"	" " film	.31 ea.
R7 -	120K	"	"	" " "	.31 ea.
R8 -	5K	Mepco pot			1.39 ea.
R9 -	1.2K	1/8 watt	5%	resistor, carbon film	.31 ea.
C1 -	.033uf	50v	CW15	capacitor, mono.	1.75 ea.
C2 -	1uf	35v	tantalum	capacitor	1.05 ea.
*C3 -	1uf	"	"	"	1.05 ea.
C4 -	.01uf	50v	CW15	capacitor, mono.	1.50 ea.
*C4A -	470pf	"	"	"	1.00 ea.
C5 -	1uf	35v	tantalum	capacitor	1.05 ea.
C6 -	100pf	50v	CW15	capacitor, mono.	1.00 ea.
C7 -	100pf	"	"	"	1.00 ea.
D1 -	1N4148	silicon	diode		.15 ea.
D2 -	1N4148	"	"		.15 ea.
D3 -	1N4148	"	"		.15 ea.
*D4 -	1N4148	"	"		.15 ea.
Y1 -	1Mhz	crystal			7.50 ea.
VR-1 -	78L08A	regulator			1.00 ea.
CSR202 -	Resistor network				2.30 ea.
SW-1 -	5 position	DIP switch			2.45 ea.
IC-107 -	Com-Spec	microcircuit			17.50 ea.
IC-1 -	TL062	microcircuit			2.20 ea.
2 -	9 pin	socket strips			.39 ea.
2 -	4 pin	socket strips			.35 ea.
3 -	AMP	chassis pins			.10 ea.
1 -	Printed	circuit board			5.00 ea.
JU-1 -	Jumper	wire			.01 ea.
	33 pos.	binary switch (for remote operation)			9.95 ea.

*These items not used on sub-audible board.

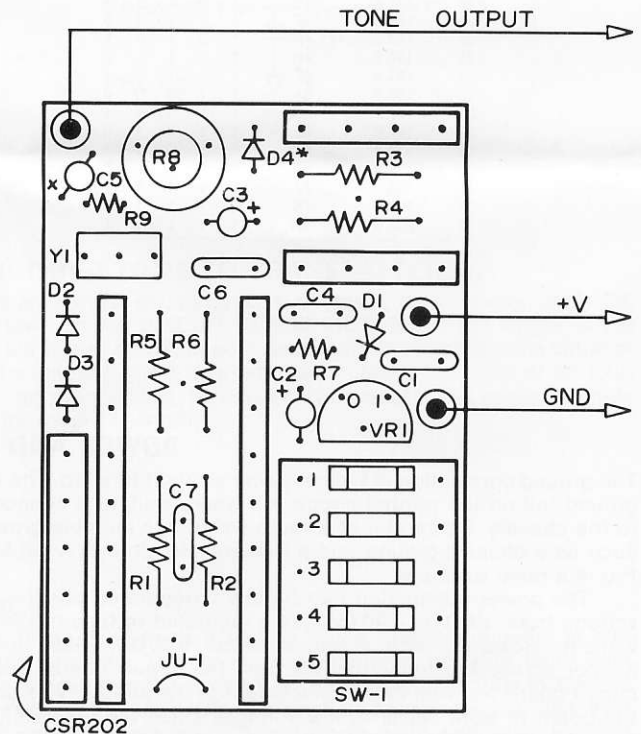

* REMOVE FOR CONTINUOUS TONE

MOUNTING

Mount the unit with the mounting items supplied. Do not mount the unit with silicon seal or any other type glues as this will void warranty. When making connections to the board be sure to use

the plug on wires supplied. Do not solder the wires to the circuit board terminals.

PROGRAMMING

This programmable line of products uses a five position DIP switch to select the frequency desired. When the switches are in any particular position, this binary code tells the integrated circuit which of the coded tones the system is to operate on. For instance, if 1Z (100.0Hz.) is desired, the code required is located on the instruction sheet and the switches are programmed accord-

ingly. For example, the code for a 1Z is "11010", thus switch #1 is turned OFF (corresponding to a "1"), switch #2 is turned OFF, switch #3 is turned ON (corresponding to a "0"), switch #4 is OFF, and switch #5 is turned ON. By selecting the variable combinations of switch positions, all 32 tones can be accessed. Special tones are available also by using a different frequency crystal.

DIP SWITCH PROGRAMMING

FOR CTCSS PRODUCTS GROUP A

#	FREQ.	CODE	SWITCH NUMBER*				
			5	4	3	2	1
1	67.0	XZ	0	0	0	0	0
2	71.9	XA	0	0	0	0	1
3	74.4	WA	0	0	0	1	0
4	77.0	XB	0	0	0	1	1
5	79.7	SP	0	0	1	0	0
6	82.5	YZ	0	0	1	0	1
7	85.4	YA	0	0	1	1	0
8	88.5	YB	0	0	1	1	1
9	91.5	ZZ	0	1	0	0	0
10	94.8	ZA	0	1	0	0	1
11	97.4	ZB	0	1	0	1	0
12	100.0	1Z	0	1	0	1	1
13	103.5	1A	0	1	1	0	0
14	107.2	1B	0	1	1	0	1
15	110.9	2Z	0	1	1	1	0
16	114.8	2A	0	1	1	1	1
17	118.8	2B	1	0	0	0	0
18	123.0	3Z	1	0	0	0	1
19	127.3	3A	1	0	0	1	0
20	131.8	3B	1	0	0	1	1
21	136.5	4Z	1	0	1	0	0
22	141.3	4A	1	0	1	0	1
23	146.2	4B	1	0	1	1	0
24	151.4	5Z	1	0	1	1	1
25	156.7	5A	1	1	0	0	0
26	162.2	5B	1	1	0	0	1
27	167.9	6Z	1	1	0	1	0
28	173.8	6A	1	1	0	1	1
29	179.9	6B	1	1	1	0	0
30	186.2	7Z	1	1	1	0	1
31	192.8	7A	1	1	1	1	0
32	203.5	M1	1	1	1	1	1

*CLOSED = 0 (ON)
OPEN = 1 (OFF)

FOR GROUP B TONES REMOVE JU-1

#	FREQ. (Hz)	SWITCH NUMBERS*				
		5	4	3	2	1
1	600.0	0	0	0	0	0
2	1000.0	0	0	0	0	1
3	1500.0	0	0	0	1	0
4	1600.0	0	0	0	1	1
5	1650.0	0	0	1	0	0
6	1700.0	0	0	1	0	1
7	1750.0	0	0	1	1	0
8	697.0	0	0	1	1	1
9	1800.0	0	1	0	0	0
10	1850.0	0	1	0	0	1
11	1900.0	0	1	0	1	0
12	770.0	0	1	0	1	1
13	1950.0	0	1	1	0	0
14	852.0	0	1	1	0	1
15	941.0	0	1	1	1	0
16	2000.0	0	1	1	1	1
17	2100.0	1	0	0	0	0
18	2150.0	1	0	0	0	1
19	2200.0	1	0	0	1	0
20	2250.0	1	0	0	1	1
21	2300.0	1	0	1	0	0
22	2350.0	1	0	1	0	1
23	2400.0	1	0	1	1	0
24	1209.0	1	0	1	1	1
25	2450.0	1	1	0	0	0
26	2500.0	1	1	0	0	1
27	2550.0	1	1	0	1	0
28	1336.0	1	1	0	1	1
29	2175.0	1	1	1	0	0
30	1477.0	1	1	1	0	1
31	1633.0	1	1	1	1	0
32	2805.0	1	1	1	1	1

*CLOSED = 0 (ON)
OPEN = 1 (OFF)

POWER AND GROUND CONNECTIONS

The ground connection is typically very straight forward. The main ground foil on the printed circuit foil works well, or a connection to the chassis. Be careful of a radio which has multiple grounds, such as a chassis ground and a true vehicle ground. A GE Mastr Pro is a good example.

The power connection can be any unregulated positive D.C. voltage from +6.0 to +30.0V. Use a regulated voltage if it is convenient. However, with voltages below 9.0VDC, place a wire jumper across the regulator (VR-1) on the circuit board. See the circuit board pictorial for the placement of the jumper. This allows the board to work better at low voltages since the regulator only operates above 9.0V. Higher voltage can also be used, however an external limiting resistor will be required so the input does not ex-

ceed 30VDC. To determine the value of the resistor (in Kohms) use the following formula: $R = (V - 22) / 8$. A two watt resistor should be sufficient for voltages up to 200VDC. Refer to figures 1, 2, 3 for additional information. If polarity is reversed to the unit, it will not operate but will not be damaged. Use the following as a guide for obtaining proper operating voltage in different environments:

Mobiles, 12V negative ground—standard hook-up (see above).
Mobiles, 12V positive ground—reverse board +V and GND connections.

Mobiles, 6V pos. or neg. ground—use B+ dropping method.
Bases—use appropriate figure 1, 2, 3.

Portables, 9V or less—by-pass regulator, VR-1.

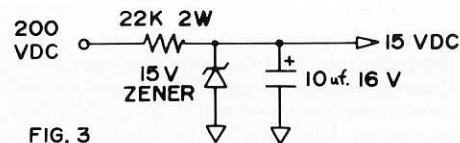
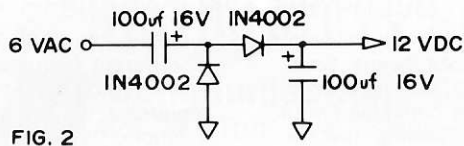
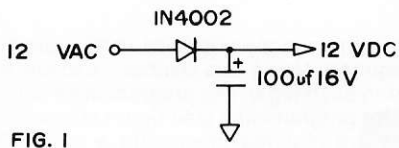

PROCEDURE FOR CONNECTING SUB-AUDIBLE ENCODER TONE TO TRANSMITTER

The encoder tone output is typically connected just prior to the modulator stage. Typical connections would be to the center of the deviation control, to the input of the final audio driver, to the varactor modulator diodes or to the manufacturer's normal connection point. This connection point varies with each different model radio, and you must determine which provides the best results. In a tube type transmitter, the grid of the modulator is often used, or a varactor kit should be used to modulate the crystal directly in a tube type or solid state transmitter, see figure E1. The VARACTOR (transistor base to collector junction of an NPN silicon transistor) changes A.C. voltage into changing capacitance which truly FM modulates the transmitter. No intermoding or distortion of the voice will be noted with this method. Various values of coupling capacitors are shown for different frequency ranges of the transmitter. A higher value of capacitance will increase the deviation level, however if the capacitance is too high, it may be difficult to set the transmitter on frequency. Varactor Kits are available from us for \$3.00 each. Use this method if other connection points prove unsuccessful.

DO NOT connect the encoder tone to the microphone input as this invariably causes excessive tone and harmonic distortion due to the frequency response of the transmitter's speech amplifier. The speech amplifier has a typical response of 300Hz to 3000Hz and does not permit the fundamental tone to be transmitted. This is the usual cause of a distorted tone output as monitored on a deviation scope.

The output of our encoder is low Z, so it is capable of driving low Z loads. Insufficient level output should never be a problem. However, if you are driving a high Z load such as 100k deviation pot, then a series isolation resistor should be used so the encoder will not load down the normal voice modulation. This resistor value must be determined experimentally, but a 100k resistor would be a good starting point. This value could change from 10K to 1 meg depending on the radio used.

If tone distortion continues to be a problem, then a capacitor can be placed on the tone output to provide additional filtering where required, see figure E2. This is most noticeable in phase modulators since the frequency response seems to be quite poor at the low end of the audio range. If you are using a deviation scope, then little spikes will be riding on the sine wave output, and this will sound like a buzz. The additional filtering will cure the problem. True FM modulators do not have this problem and are very easy to work with and interface very well with sub-audible encoders. These modulators can be identified quite easily since the audio is fed into a varactor which is often connected in parallel with the crystal. If the purity of the encoder output is in question, look at the output of the encoder with an oscilloscope.

Most UHF transmitters interface quite well with sub-audible encoders. This is primarily due to the high multiplication factor from the modulator to the final amplifier stage. Because of the lower number of multiplication stages in low band transmitters, sufficient deviation level can sometimes be difficult to obtain.

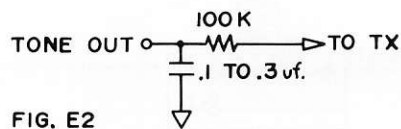
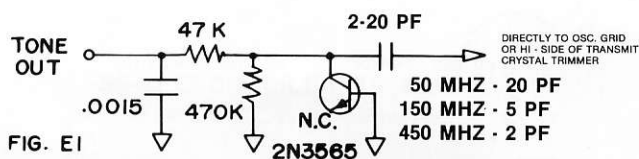

PROCEDURE FOR CONNECTING AUDIBLE ENCODER TONE TO TRANSMITTER

Audible tone can be connected directly to the microphone input. When driving a high impedance load, a series isolation resistor will be required so the voice modulation will not be affected. If insufficient level seems to be a problem, then inject the tone at the input of the next amplifier stage in the transmitter. Be sure to use a series resistor if modulation level is reduced. If continuous tone

is required when encoding from Group B, then remove diode D4, as shown on the CIRCUIT BOARD PICTORIAL. The length of the tone burst may be changed if necessary by adjusting the value of R3. If a longer burst is desired, then increase the value of R3 100k ohms for every 100ms. increase in tone length. The opposite holds true for reduced length.

RF INTERFERENCE

Although our encoders are not susceptible to RF, care must be taken when locating the unit, and how the wires are routed. In most cases of RF interference it has been found that the RF is coupled into the leads of the encoder and then fed back into the radio itself where the RF upsets the bias conditions in the transmitter. This causes distortion and other unusual effects. But

under these conditions it will be noted that the encoder is still working properly. This is most common in portable hand held radios, since often the circuitry is compromised slightly to achieve the small size required. Often a small by-pass capacitor such as a 100pf. on the radio's circuit board works quite well. Also, keeping all leads as short as possible or re-routing the wires helps.

MULTI-TONE APPLICATIONS

By adding a little additional circuitry, our programmable line of products may be frequency programmed by remote means. Since these products all use DC signals for switching, any number of tones may be switched in or out without being concerned with additional lead length, or stray capacitance affecting the frequency. This is a typical problem associated with tunable or reed type units.

There are a number of ways of changing frequencies from a remote location. The easiest way is to use a 33 position binary switch (available from us) which connects in parallel with the 5 position DIP switch on the circuit board. Thus all 32 tones may be accessed by rotating through all positions on the switch, with the first position on the switch being the off condition (see figure M1). When connections are made in this manner, position ONE will be the off condition, and the path from "G" to "H" will be open thereby removing power from the programmable board. Position TWO would be 67.0Hz (Group A), position three would be 71.9Hz, and so on up to position 33 which would be 203.5Hz. When using the binary switch be sure all five positions on the DIP switch are in the OFF condition.

The other method for adding additional frequencies is to use

a single pole rotary switch with as many positions as the number of different frequencies required. Using this method, a diode for line isolation must be used in each leg of the program code which requires a "0" or a ground for programming (see figure M2). In this example, three frequencies are required to operate a three site repeater system. The sub-audible tones required to access all three sites are 5Z (151.4Hz), 4B (146.2Hz), and YZ (82.5Hz). The frequency code is located on the programming chart for each of the three frequencies and these codes are converted to the appropriate diode array for each frequency. For example, position number two on the rotary switch must be 146.2Hz. This corresponds to "10110" on the program chart. By looking at this code, it is determined that 2 diodes will be required on the locations containing a "0", and no connection is required in the locations containing a "1". Thus the lines from pin 11, and pin 14, on IC-107 are pulled to ground through the series diodes when the rotary switch is in position number two. This method works quite well where space is a factor, and is best when only a few frequencies are required. Be sure all five positions on the DIP switch are in the OFF condition when changing frequencies remotely.

