

TS-64/84-7000 SPECIAL MODIFICATION SHEET

DANIELS VERSION

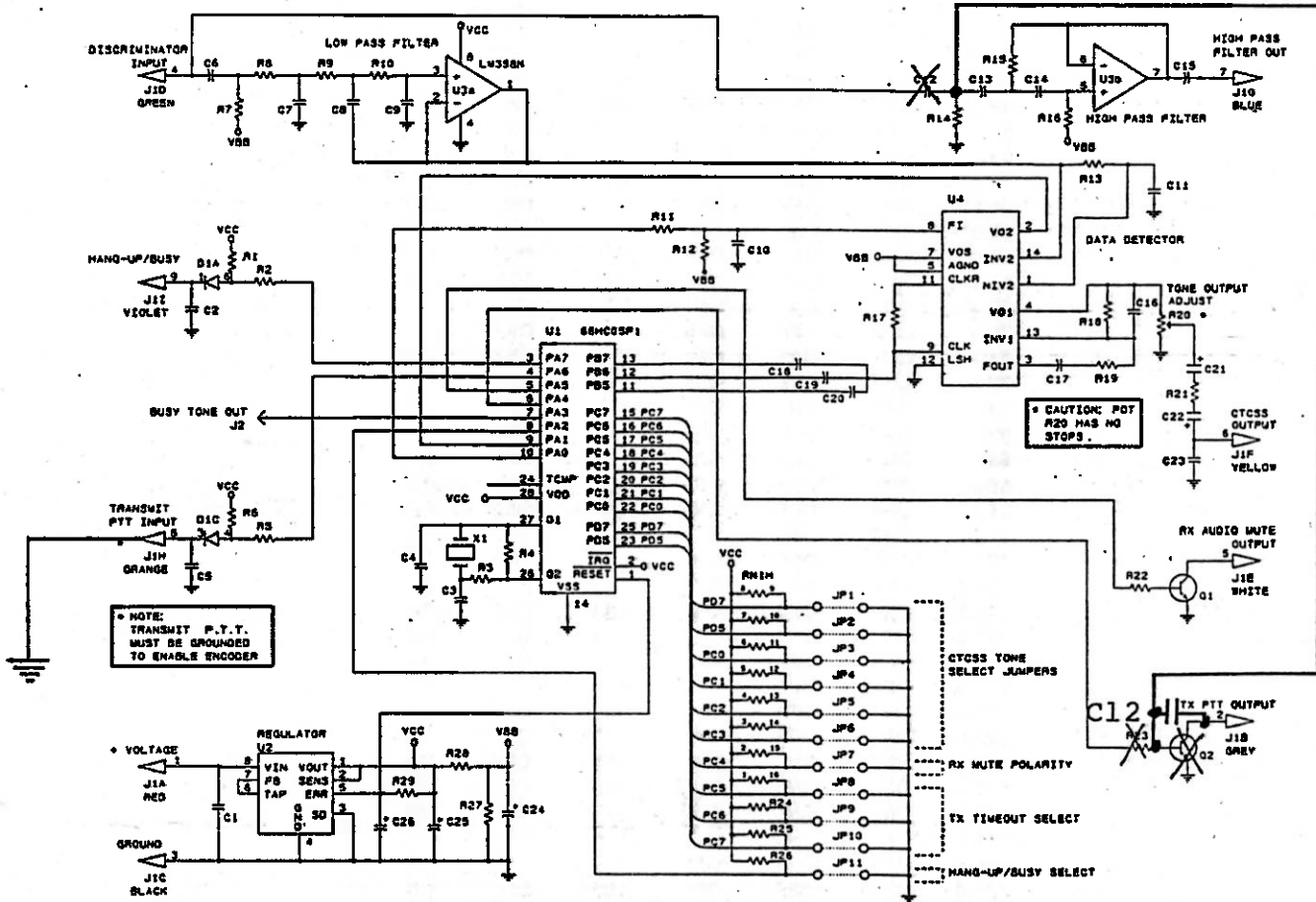

84-7000

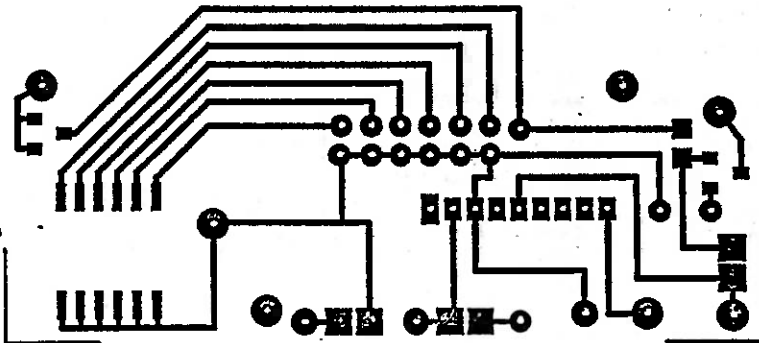

JU-3 JU-2

84-7000 JUMPER PLACEMENT

- JU-1 (IN) Same as JU-1 on TS-32P
- JU-2 (IN) To allow "Split Input Mod" above
- JU-3 (IN) To continuously enable tone output

TS-64 MODIFICATIONS

1. Remove C12 from bottom of PCB.
2. Remove R23 and Q2 from top of PCB.
3. Add C12 (4700pf) from base to collector of Q2.
4. Add jumper from junction of R14/C13 on bottom of board to base of Q2 on top of PCB.
5. This makes Pin 2 (grey TX PTT Out) the INPUT to the High Pass Audio Filter.
6. JP-7 on TS-64 is (IN).
7. Supply BOTH SS-64 AND TS-64 instruction sheets to allow tone programming with dip switch on 84-7000 PCB.

Please Note:
 The TS-32P is no longer available
 and has been replaced by the
 enclosed TS-64DS, CTCSS
 Encoder/Decoder with Dip Switch

TS-64DS DIP Switch Programming Chart

TONE	#1	#2	#3	#4	#5	#6
33.0*	OFF	ON	ON	OFF	OFF	OFF
35.4*	ON	ON	ON	OFF	OFF	OFF
36.6*	OFF	OFF	OFF	ON	OFF	OFF
37.9*	ON	OFF	OFF	ON	OFF	OFF
39.6*	OFF	ON	OFF	ON	OFF	OFF
44.4*	ON	ON	OFF	ON	OFF	OFF
47.5*	OFF	OFF	OFF	ON	ON	OFF
49.2*	ON	OFF	OFF	ON	ON	OFF
51.2*	OFF	ON	OFF	ON	ON	OFF
53.0*	ON	ON	OFF	ON	ON	OFF
54.9*	OFF	OFF	ON	ON	ON	OFF
56.8*	ON	OFF	ON	ON	ON	OFF
58.8*	OFF	ON	ON	ON	ON	OFF
63.0*	ON	ON	ON	ON	ON	OFF
67.0	OFF	OFF	OFF	OFF	OFF	OFF
69.4*	ON	ON	ON	OFF	ON	OFF
71.9	OFF	OFF	OFF	OFF	OFF	ON
74.4	ON	OFF	OFF	OFF	OFF	OFF
77.0	OFF	OFF	OFF	OFF	OFF	ON
79.7	OFF	ON	OFF	OFF	OFF	OFF
82.5	ON	OFF	OFF	OFF	OFF	ON
85.4	ON	ON	OFF	OFF	OFF	OFF
88.5	ON	OFF	OFF	OFF	ON	ON
91.5	OFF	OFF	ON	OFF	OFF	OFF
94.8	OFF	ON	OFF	OFF	OFF	ON
97.4*	ON	OFF	ON	OFF	OFF	OFF
100.0	OFF	ON	OFF	OFF	ON	ON
103.5	ON	ON	OFF	OFF	OFF	ON
107.2	ON	ON	OFF	OFF	ON	ON
110.9	OFF	OFF	ON	OFF	OFF	ON
114.8	OFF	OFF	ON	OFF	ON	ON
118.8	ON	OFF	ON	OFF	OFF	ON
123.0	ON	OFF	ON	OFF	ON	ON
127.3	OFF	ON	ON	OFF	OFF	ON
131.8	OFF	ON	ON	OFF	ON	ON
136.5	ON	ON	ON	OFF	OFF	ON
141.3	ON	ON	ON	OFF	ON	ON
146.2	OFF	OFF	OFF	ON	OFF	ON
151.4	OFF	OFF	OFF	ON	ON	ON
156.7	ON	OFF	OFF	ON	OFF	ON
159.8*	OFF	ON	ON	OFF	ON	OFF
162.2	ON	OFF	OFF	ON	ON	ON
165.5*	ON	OFF	ON	OFF	ON	OFF
167.9	OFF	ON	OFF	ON	OFF	ON
171.3*	OFF	OFF	ON	OFF	ON	OFF
173.8	OFF	ON	OFF	ON	ON	ON
177.3*	ON	ON	OFF	OFF	ON	OFF
179.9	ON	ON	OFF	ON	OFF	ON
183.5*	OFF	ON	OFF	OFF	ON	OFF
186.2	ON	ON	OFF	ON	ON	ON
189.9*	ON	OFF	OFF	OFF	ON	OFF
192.8	OFF	OFF	ON	ON	OFF	ON
196.6*	OFF	OFF	OFF	OFF	ON	OFF
199.5*	ON	ON	ON	ON	OFF	OFF
203.5	OFF	OFF	ON	ON	ON	ON
206.5*	OFF	ON	ON	ON	OFF	OFF
210.7	ON	OFF	ON	ON	OFF	ON
218.1	ON	OFF	ON	ON	ON	ON
225.7	OFF	ON	ON	ON	OFF	ON
229.1*	ON	OFF	ON	ON	OFF	OFF
233.6	OFF	ON	ON	ON	ON	ON
241.8	ON	ON	ON	ON	OFF	ON
250.3	ON	ON	ON	ON	ON	ON
254.1*	OFF	OFF	ON	ON	OFF	OFF

*NON EIA STANDARD TONES

NOTE:

1. If it becomes necessary to remove the TS-64 from the 84-7000 PCB, extract the solder from the holes in the bottom of the 84-7000 only.

TS-64 INSTRUCTION SHEET

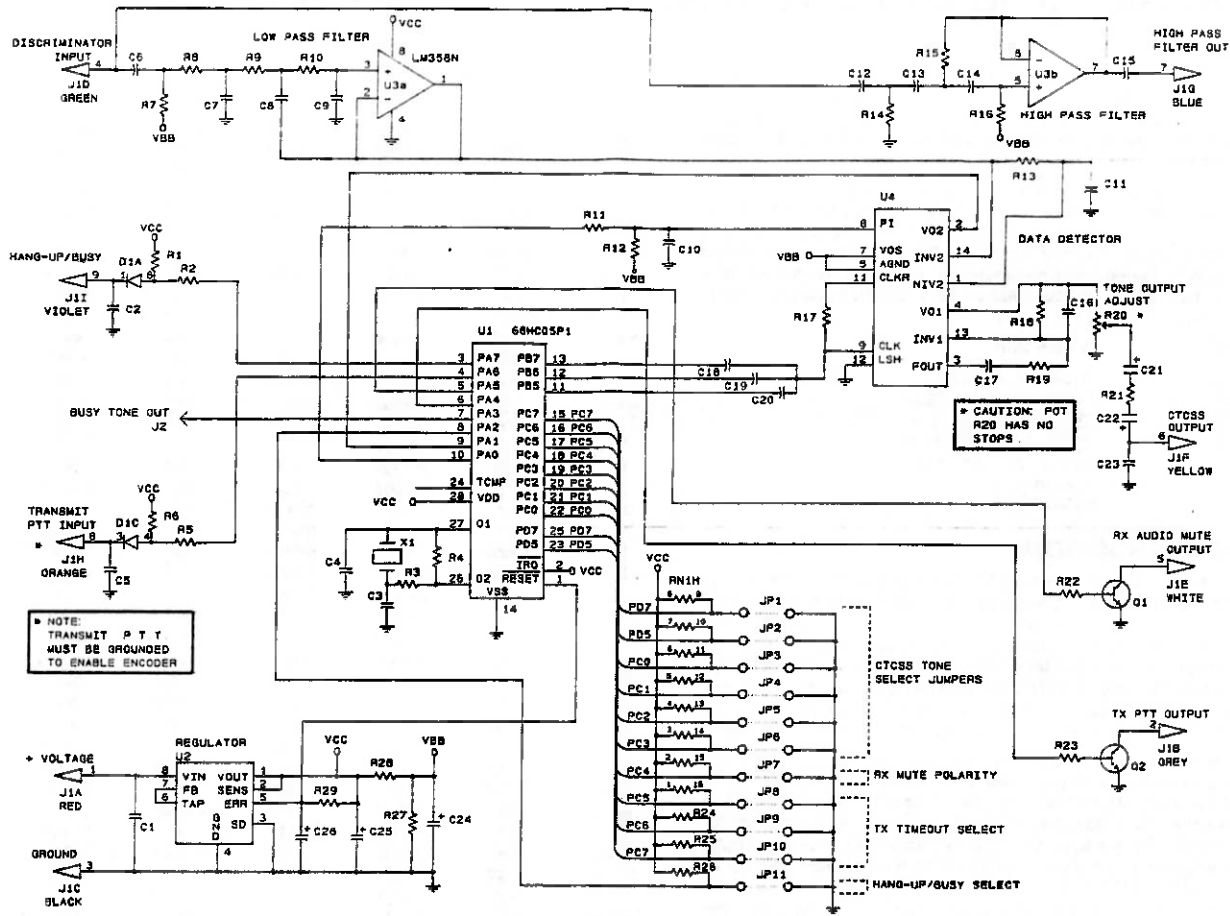

PARTS LIST

DESIG.	CSI NO.	DESCRIPTION	PRICE	DESIG.	CSI NO.	DESCRIPTION	PRICE
U1	51-6805	CMOS Microprocessor	15.50 ea.	R21,R23	06-2226	2.2K, 1/8w, 5%, 0805 Chip Resistor	.10 ea.
	TS-64			R15	06-3626	3.6K, 1/8w, 5%, 0805 Chip Resistor	.10 ea.
U2	48-2951	LP2951CM Low Dropout Regulator	2.85 ea.	R22,R27	06-4726	4.7K, 1/8w, 5%, 0805 Chip Resistor	.10 ea.
U3	51-0358	LM358D Dual OP-AMP	.66 ea.	R28	06-7526	7.5K, 1/8w, 5%, 0805 Chip Resistor	.10 ea.
U4	51-6500	MF6CWM-50 Low Pass Filter	5.82 ea.	R3,R17	06-1136	11K, 1/8w, 5%, 0805 Chip Resistor	.10 ea.
D1	48-0010	IMN10 Triple Diode Array	.43 ea.	R11,	06-3336	33K, 1/8w, 5%, 0805 Chip Resistor	.10 ea.
Q1	48-4200	MMBTA42LT1 NPN Si Transistor	.28 ea.	R12,R14			
Q2	48-0056	BCX56 NPN Si SOT-89 Transistor	.80 ea.	R1,R2,R5,	06-4736	47K, 1/8w, 5%, 0805 Chip Resistor	.10 ea.
X1	48-3835	AT38-3.587M Crystal	1.80 ea.	R6,R24,			
C24	19-6826	6.8 µf, 4v, 20% Tant. Chip Capacitor	.84 ea.	R25,R26			
C21,C22	19-2226	2.2 µf, 16v, 20% Tant. Chip Capacitor	.54 ea.	R19	06-8236	82K, 1/8w, 5%, 0805 Chip Resistor	.10 ea.
C25,C26	19-1056	1µf, 20v, 20% Tant. Chip Capacitor	.78 ea.	R7,R18	06-9136	91K, 1/8w, 5%, 0805 Chip Resistor	.10 ea.
C1,C6,	22-1040	.1µf, X7R, 50v, 10%, 1206 Mono,	.25 ea.	R9,R10,R29	06-1648	160K, 1/8w, 5%, 0805 Chip Resistor	.10 ea.
C8,C15,C17		Chip Cap.		R8	06-2046	200K, 1/8w, 5%, 0805 Chip Resistor	.10 ea.
C7,C10,	22-1030	.01µf, X7R, 50v, 10%, 0805 Mono,	.25 ea.	R13	06-6846	680K, 1/8w, 5%, 0805 Chip Resistor	.10 ea.
C11		Chip Cap.		R4,R16	06-2756	2.7Meg, 1/8w, 5%, 0805 Chip Resistor	.10 ea.
C20	22-6820	6800pf, X7R, 50v, 10%, 0805 Mono.	.25 ea.	R20	18-5026	5K,3MM Chip Trimmer Pot	.82 ea.
		Chip Cap.		RN1	51-1215	47K x 8 Chip Resistor Network	.75 ea.
C12,C13,	22-4720	4700pf, X7R, 50v, 10%, 0805 Mono,	.25 ea.	J1	09-8717	9 Pin Sub-Miniature Header	.87 ea.
C14,C19		Chip Cap.			01-1023	9 Pin Plug-In Cable Assembly	2.50 ea.
C16,C18	22-3320	3300pf, X7R, 50V, 10%, 0805 Mono.	.25 ea.		84-1056	TS-64 PCB	8.75 ea.
		Chip Cap.			68-2084	TS-64 Instruction Sheet	.50 ea.
C2,C5,C9,	22-1810	180pf, NPO, 50v, 10%, 0805 Mono.	.25 ea.		75-1002	Double Sided Tape Squares	.07 ea.
C23		Chip Cap.			56-1001	CSI Tuning Tool	.20 ea.
C3,C4	22-2200	22pf, NPO, 50v, 10%, 0805 Mono.	.25 ea.				
		Chip Cap.					

MODEL TS-64

MINIATURE 64 TONE CTCSS ENCODER-DECODER

The Communications Specialists Model TS-64 Miniature 64 Tone CTCSS Encoder-Decoder is a microprocessor based product used for encoding and decoding subaudible tones. The TS-64 is compatible with continuous tone controlled squelch systems (CTCSS) used in land mobile radio such as 'Private Line', 'Channel Guard', and 'Quiet Channel'.

Because of its small size and low power consumption, advanced engineering has resulted in a product that is ideal for mobile and portable two-way FM radio installations. Simple field programming by PCB jumper straps allows the radio service shop to configure the CTCSS tone, Receive Audio Mute polarity, Transmit Time-out-timer, and the Hang-up/Busy function. Squelch tail elimination is achieved by the use of a 'reverse phase burst' at the end of each transmission. An audio high pass filter eliminates the CTCSS signal from the recovered audio.

Section	Description
1.0	Operating Instructions
2.0	Programming the TS-64
2.1	CTCSS Code
2.2	Transmit Time-out-timer
3.0	Installation Instructions
3.1	Adjustments
4.0	TS-64 Specifications

1.0 OPERATING INSTRUCTIONS

The TS-64 is designed to encode and decode CTCSS transmissions in conjunction with an associated FM radio transceiver. Upon receipt of a programmed CTCSS coded transmission, the TS-64 will unmuter the receiver audio and allow audio to pass. While the TS-64 is decoding, an internal timer keeps the audio path open for approximately 350 ms during a loss of signal due to signal fade. Upon receipt of the turn off code, the TS-64 will immediately mute the receive audio thus eliminating the squelch tail that is usually heard at the end of a transmission. The Microphone Hang-up input allows the operator to override the decoder and open up the audio path for channel monitoring.

When the PTT switch is keyed on the microphone, the TS-64 will key the transmitter and immediately begin generating the programmed CTCSS tone for transmission. The TS-64 will continue to generate the CTCSS tone for as long as the PTT switch is pressed. Upon release of the PTT switch, the TS-64 will continue to key the transmitter for approximately 160ms. During this time, the TS-64 will generate a reverse phase burst which will mute the decoding unit at the other end of the transmission medium. At the end of the 160 ms period, the TS-64 will unkey the transmitter. If activated, an internal Transmit Time-out-timer will limit transmissions to a programmed length, thus eliminating problems with stuck microphones and the like.

2.0 PROGRAMMING THE TS-64

This section of the instructions describes how to program the TS-64 to suit the needs of your radio system. These programming features are designed to be programmed by the installing technician. The TS-64 may be programmed before or after it is installed in the associated radio set. The TS-64 is programmed by installing 'solder bridges' across the various jumper straps, JP1-JP11 on the TS-64 printed circuit board. A low wattage soldering iron with a small tip should be used to place a small solder bridge across the various jumper straps. When programming the unit, be careful not to damage the TS-64 printed circuit board. The TS-64 comes from the factory with the jumper straps set for the most common configuration. See the Parts Layout diagram for the location of the jumper straps.

2.1 CTCSS TONE

The CTCSS tone is programmed by Jumper Straps, JP1-JP6. A total of 64 different subaudible tones can be selected. The table below indicates how to program a CTCSS tone. In the case where the table indicates 'out', this means that no solder bridge should be installed across the jumper strap. In the case where the table indicates 'bridge', this means that a solder bridge should be installed across that jumper strap. Please note that tones marked with a '*' are not EIA tones, should only be used for special applications, and may not work in harmony with adjacent EIA tones.

TONE	JP1	JP2	JP3	JP4	JP5	JP6
33.0*	out	bridge	bridge	out	out	out
35.4*	bridge	bridge	bridge	out	out	out
36.6*	out	out	out	bridge	out	out
37.9*	bridge	out	out	bridge	out	out
39.6*	out	bridge	out	bridge	out	out
44.4*	bridge	bridge	out	bridge	out	out
47.5*	out	out	out	bridge	bridge	out
49.2*	bridge	out	out	bridge	bridge	out
51.2*	out	bridge	out	bridge	bridge	out
53.0*	bridge	bridge	out	bridge	bridge	out

TONE	JP1	JP2	JP3	JP4	JP5	JP6
54.9*	out	out	bridge	bridge	bridge	out
56.8*	bridge	out	bridge	bridge	bridge	out
58.8*	out	bridge	bridge	bridge	bridge	out
63.0*	bridge	bridge	bridge	bridge	bridge	out
67.0	out	out	out	out	out	out
69.4*	bridge	bridge	bridge	out	bridge	out
71.9	out	out	out	out	out	bridge
74.4	bridge	out	out	out	out	out
77.0	out	out	out	out	bridge	bridge
79.7	out	bridge	out	out	out	out
82.5	bridge	out	out	out	out	bridge
85.4	bridge	bridge	out	out	out	out
88.5	bridge	out	out	out	bridge	bridge
91.5	out	out	bridge	out	out	out
94.8	out	bridge	out	out	out	bridge
97.4*	bridge	out	bridge	out	out	out
100.0	out	bridge	out	out	bridge	bridge
103.5	bridge	bridge	out	out	out	bridge
107.2	bridge	bridge	out	out	bridge	bridge
110.9	out	out	bridge	out	out	bridge
114.8	out	out	bridge	out	bridge	bridge
118.8	bridge	out	bridge	out	out	bridge
123.0	bridge	out	bridge	out	bridge	bridge
127.3	out	bridge	bridge	out	out	bridge
131.8	out	bridge	bridge	out	bridge	bridge
136.5	bridge	bridge	bridge	out	out	bridge
141.3	bridge	bridge	bridge	out	bridge	bridge
146.2	out	out	out	bridge	out	bridge
151.4	out	out	out	bridge	bridge	bridge
156.7	bridge	out	out	bridge	out	bridge
159.8*	out	bridge	bridge	out	bridge	out
162.2	bridge	out	out	bridge	bridge	bridge
165.5*	bridge	out	bridge	out	bridge	out
167.9	out	bridge	out	bridge	out	bridge
171.3*	out	out	bridge	out	bridge	out
173.8	out	bridge	out	bridge	bridge	bridge
177.3*	bridge	bridge	out	out	bridge	out
179.9	bridge	bridge	out	bridge	out	bridge
183.5*	out	bridge	out	out	bridge	out
186.2	bridge	bridge	out	bridge	bridge	bridge
189.9*	bridge	out	out	out	bridge	out
192.8	out	out	bridge	bridge	out	bridge
196.6*	out	out	out	out	bridge	out
199.5*	bridge	bridge	bridge	bridge	out	out
203.5	out	out	bridge	bridge	bridge	bridge
206.5*	out	bridge	bridge	bridge	out	out
210.7	bridge	out	bridge	bridge	out	bridge
218.1	bridge	out	bridge	bridge	bridge	bridge
225.7	out	bridge	bridge	bridge	out	bridge
229.1*	bridge	out	bridge	bridge	out	out
233.6	out	bridge	bridge	bridge	bridge	bridge
241.8	bridge	bridge	bridge	bridge	out	bridge
250.3	bridge	bridge	bridge	bridge	bridge	bridge
254.1*	out	out	bridge	bridge	out	out

Alternatively, a binary switch can be connected to the jumper straps, this will allow the user to change the CTCSS code at any time. When connecting a switch to the jumper straps, connect the switch common to ground, and the wires from the switch to the side of the jumper strap closest to the microprocessor chip U1 that has the hole.

2.2 TRANSMIT TIME-OUT-TIMER

The Transmit Time-out-timer is used to limit the duration of a continuous transmission to a maximum length as programmed by the Jumper Straps, JP8, JP9, and JP10. The timer can be programmed with eight different timeout intervals. These are listed in the table below. The Transmit Time-out-timer is disabled when received from the factory.

TIMEOUT INTERVAL	JP8	JP9	JP10
DISABLED	out	out	out
15 seconds	bridge	out	out
30 seconds	out	bridge	out
45 seconds	bridge	bridge	out
1 minute	bridge	out	bridge
2 minutes	out	bridge	bridge
3 minutes	out	out	bridge
5 minutes	bridge	bridge	bridge

TOP SIDE PARTS LAYOUT

JP10
 JP9
 JP8
 JP7
 JP6
 JP5
 JP4
 JP3
 JP2
 JP1

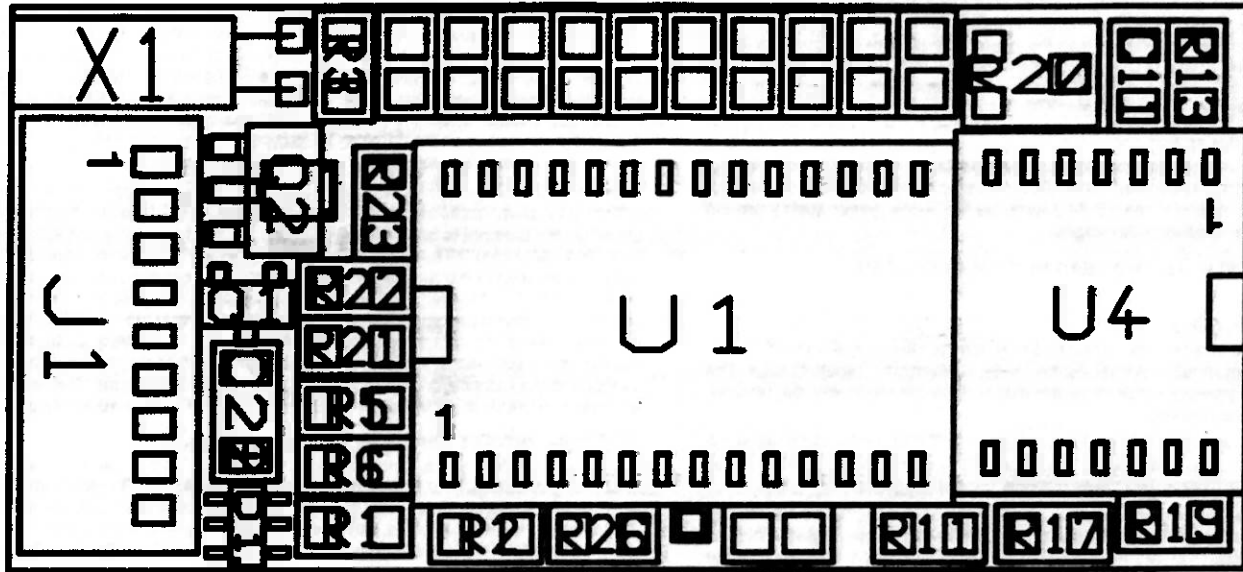

JP11
 J2

BOTTOM SIDE PARTS LAYOUT

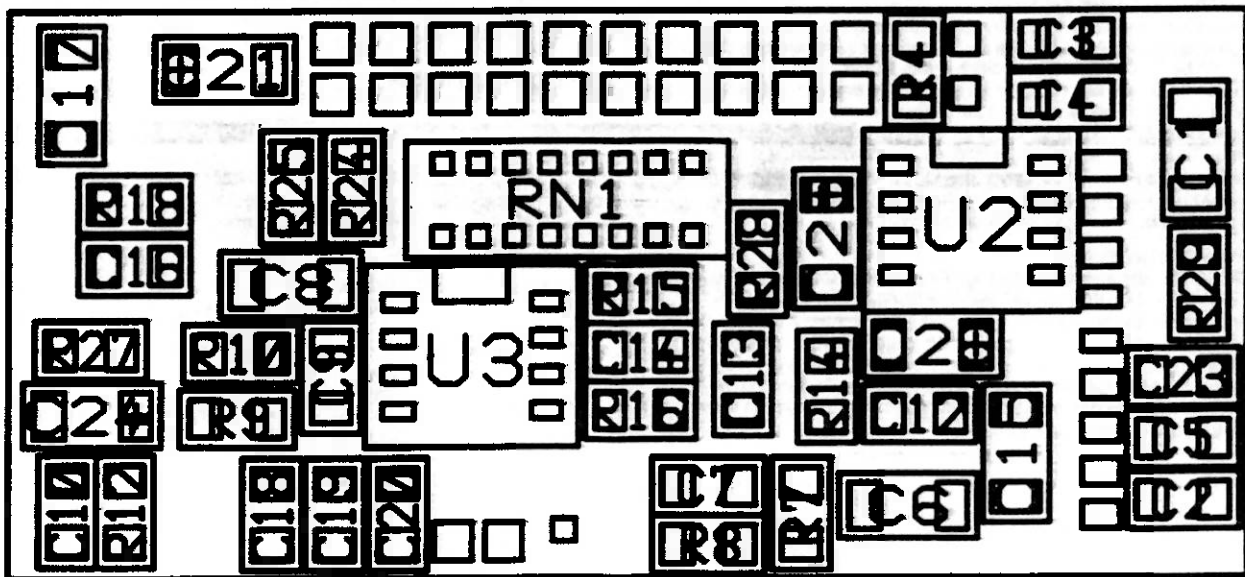

COMMUNICATIONS SPECIALISTS, INC.

426 WEST TAFT AVENUE • ORANGE, CA 92865-4296

(714) 998-3021 • FAX (714) 974-3420

Entire U.S.A. (800) 854-0547 • FAX (800) 850-0547

<http://www.com-spec.com>

3.0 INSTALLATION INSTRUCTIONS

Installation of the TS-64 should be done by a qualified two-way radio technician. When installing the TS-64 be careful not to twist or bend the printed circuit board as this can damage the surface mount components. In addition, use static protection techniques while handling the unit. Be sure that all power is removed before installing or programming the TS-64. The following paragraphs describe each of the external connections on the TS-64:

+ VOLTAGE (RED) (Pin 1)

This wire should be connected directly to a filtered source of continuous positive DC voltage in the range of +8.0VDC to +20.0VDC. This connection should be made "downstream" from the power switch, and the power supply filter components in the radio set. If a regulated source of DC voltage is available, it may be used. Using a quiet and stable source of DC voltage inside the radio set will reduce the possibility of picking up power supply noise.

GROUND (BLACK) (Pin 3)

The Ground wire should be connected to a location inside the radio set which will supply a DC power ground return to the TS-64. To eliminate ground loops and power supply noise, the ground return to the TS-64 should be the same power supply ground used in the transmit or receive audio stages.

PTT INPUT (ORANGE) (Pin 8) THIS LEAD MUST BE GROUNDED TO ENCODE TONE

PTT OUTPUT (GREY) (Pin 2)

The PTT Input detects a transmit condition by sensing a 'pull to ground' on the PTT line of the radio set. This information is used by the TS-64 to determine transmit status. The PTT Output line is an open collector transistor that pulls to ground to key the transmitter during CTCSS transmission.

To install the PTT Input and PTT Output lines, cut the PTT line on the radio set at the microphone connector, and insert the PTT Input and PTT Output on the TS-64 in series with the transmitter's PTT line. The TS-64 will now control the transmit PTT line.

As an alternative to simplify the installation, the PTT Input line on the TS-64 may be permanently grounded, and the PTT Output line can be left unconnected. This will enable the TS-64 encoder at all times. If this arrangement is used, be sure that the Transmit Time-out-timer on the TS-64 is disabled. A reverse phase burst will of course not be sent.

CTCSS OUTPUT (YELLOW) (Pin 6)

This output generates the CTCSS encode tone. The most common place to connect this line is just prior to the modulation stage in the transmitter. Typical connections would be to the center of the deviation pot, to the varactor diode in the modulator circuit, or to the manufacturer's suggested connection point. This connection point can vary from radio to radio. Do not connect the CTCSS Output to the microphone input as the microphone audio stages will distort and attenuate the CTCSS signal.

Since the CTCSS Output on the TS-64 is low impedance, you may have to install a series resistor to reduce the loading effects of the CTCSS Output depending on the interface impedance. This is evident in the case of connecting to the center of a 100K deviation pot. In this case, a 100K series resistor will compensate for the impedance difference. In addition, a slight adjustment of the voice deviation may be required to compensate for the CTCSS Output circuit loading.

RECEIVE AUDIO MUTE OUTPUT (WHITE) (Pin 5)

This output is an open collector transistor that either pulls to ground to mute receive audio, or pulls to ground to open receive audio. The configuration is determined by the PCB jumper strap JP7 on the TS-64 PCB. The Receive Audio Mute Output is usually connected to the collector of the 'squelch switch transistor' in the receiver. To find the correct connection point for the Receive Audio Mute Output, locate a point in the receiver squelch circuit that will either 'mute' or 'open' the receiver audio upon application of a ground potential. This will be the correct point for connection. Then configure JP7 for the correct audio mute polarity. To configure the TS-64 for the most common configuration (pull to ground to mute the receive audio) do not install JP7. For a pull to ground to open the receive audio, place a solder bridge across JP7.

DISCRIMINATOR INPUT (GREEN) (Pin 4)

This wire feeds the CTCSS decoder and the Audio High Pass Filter in the TS-64. This connection MUST be made directly to the receiver discriminator output in the receiver. Please note that many discriminator circuits have a low pass filter on the discriminator output that consists of a small inductor and a capacitor. This filter network is used to attenuate very high frequency components. In the case where this network is used, the TS-64 Discriminator Input should be connected AFTER this network. Connecting the Discriminator Input after any audio processing circuitry in the receiver may distort and attenuate the CTCSS signal and produce unreliable decoding.

HIGH PASS FILTER OUTPUT (BLUE) (Pin 7)

The High Pass Filter Output removes the CTCSS signal from the receiver discriminator audio so that the operator will not hear it. In many cases, the audio response of the receiver will not pass the CTCSS signal, and the High Pass Filter on the TS-64 will not be required. In those cases where the High Pass Filter must be utilized, break the discriminator audio path in the receiver just after the point where the TS-64 Discriminator Input was connected. Then install the High Pass Filter Output so that it is in series with the audio path in the receiver.

HANG-UP/BUSY INPUT (VIOLET) (Pin 9)

This is a dual function input that is determined by the PCB Jumper Strap, JP11. When this jumper is removed, this input will operate as a Microphone hang-up input, and control the 'channel monitoring' function in the TS-64. When the Hang-up Input is floating or above ground potential (mic is off-hook), the TS-64 will be in the monitor mode, and will unmute the receiver audio. If this input is grounded, such as through a mic hang-up button, the receiver audio will be muted. The audio path in the receiver will only be enabled upon receipt of the correct CTCSS code. Connect the Hang-up Input to the microphone hookswitch connection on the microphone jack.

When the PCB Jumper Strap, JP11 is installed, the Hang-up/Busy Input will operate as a Busy Input, and disable the transmit function in the TS-64 if the operator tries to transmit when the channel is busy. However, if the TS-64 is currently decoding a CTCSS tone, and the channel is busy, the transmit function will be allowed. Connect the Busy Input to a location in the receiver that will provide an indication as to the status of the channel. The usual location is the squelch switch transistor in the receiver. A busy channel is defined as a logic high, or a voltage level greater than 1.5VDC. Please note that this is the same connection point as the Receive Audio Mute Output. The Busy Input must be connected AHEAD of the Receive Audio Mute Output with a diode in series, and the cathode of the diode connected to the Busy Input. This arrangement will isolate the Busy Input from being controlled by the Receive Audio Mute Output.

BUSY TONE OUTPUT (DIRECT PCB CONNECTION) (J2)

The Busy Tone Output is a connection on the TS-64 PCB that generates a busy tone under two conditions. First, if the programmed interval for the Transmit Time-out-timer is exceeded, the Busy Tone Output will generate the busy tone until the microphone PTT switch is released. Second, if the Hang-up/Busy Input is configured for Busy operation, and the PTT switch is pressed while the channel is busy, the Busy Tone Output will generate the busy tone until the microphone PTT switch is released.

This Output can be connected to the input of the audio amplifier stage in the receiver. The busy tone will then be heard in the speaker of the radio set. A 100K resistor and a .01uf capacitor must be placed in series with the Busy Tone Output in order to provide isolation between the TS-64 and the associated receiver.

3.1 ADJUSTMENTS

The CTCSS Output Adjustment, R20, is the only adjustment required on the TS-64. This control sets the level of the CTCSS Output. A very small slotted alignment tool should be used to make the adjustment on the TS-64 PCB. To adjust the CTCSS Output level to the correct deviation, key the PTT switch on the microphone, and while watching a deviation scope tuned to the transmit output frequency, carefully adjust the CTCSS Output Adjustment. The deviation level of the CTCSS Output should be set to 0.75 kHz (750 Hz). Please note that R20 has no stops.

A deviation scope on a service monitor is best for adjusting the CTCSS deviation. The CTCSS waveform on the scope will appear as a sine wave. If the CTCSS signal appears distorted, this indicates that the interface connection is incorrect, and must be changed to a more suitable location.

4.0 SPECIFICATIONS

Number of tones	64
Tone Accuracy	better than 0.05 Hz.
Tone Stability	crystal controlled
Encode Output Z	2.2 K ohms AC coupled
Encode Output Level	Adjustable from 0V to 3.0V
Discriminator Input Z	60K ohms AC coupled
Decode Input Level	15 Mv minimum
Signal to Noise	Better than 4 dB Sinad
Decode time	150 ms. Nominal
Fade Time	350 ms. Nominal
Squelch tail elimination	160ms reverse phase burst
CTCSS Tone Programming	by 6 PCB jumper straps
RX Mute Output	Open collector transistor
TX PTT Output	Open collector transistor
Receive Audio Filter	3 pole 330Hz High-pass filter
Busy Tone Output	5V pk-pk at 1000Hz
Temperature Range	- 30°C to + 65°C
Supply Requirements	6.0 to 20.0 VDC @9 Ma.
Size	0.78" x 1.70" x 0.25"



COMMUNICATIONS SPECIALISTS, INC.

426 WEST TAFT AVENUE • ORANGE, CA 92865-4296

(714) 998-3021 • FAX (714) 974-3420

Entire U.S.A. (800) 854-0547 • FAX (800) 850-0547

<http://www.com-spec.com>