



[Home](#) | [Contact Us](#) | [Company Info](#) | [Dealer Login](#) | [Products](#) | [Support](#) | [Employment](#) | [Search](#)

[Back To Product Manuals Main Page](#)

CES RM-10 Repeater Maker Installation and Programming Instructions

Obsolete Product

I - INTRODUCTION:

The CES RM-10 Repeater Maker is a compact repeater control unit that can make a repeater out of just about any two transceivers. The standard features and versatility make this an ideal choice for amateur or commercial use.

The RM-10 Repeater Maker Includes:

Courtesy Beep or Roger Beep

Auxiliary Relay

Adjustable Hang-Time

Remote Repeat Inhibit

Compact Attractive Case

Adjustable Time-Out Timor

Power. COR (Carrier Operated Relay), and Push to Talk L.E.D.s

Connections for CTCSS Decoder/Encoder

(sub-audible tone squelch)

Repeat Inhibit Front Panel Switch

Inputs for Full or Half Duplex Telephone Interconnect

MAKE SURE RADIOS ARE IN PROPER WORKING ORDER AND SUITABLE FOR THE APPLICATION BEFORE BEGINNING INSTALLATION OF THE REPEATER MAKER. PROBLEMS RELATED TO PROPER ANTENNA SEPARATION AND/OR DUPLEXERS AND MEASURES TO ELIMINATE RECEIVER DESENSING SHOULD BE ADDRESSED BEFORE ATTEMPTING TO PUT ANY REPEATER ON THE AIR.

II. CONNECTIONS:

All connections to the radio equipment are made via the rear panel edge connector. Care should be taken when soldering wires to the connector to avoid possible shorts between pins which could damage the Repeater Maker and radio equipment. An optional 40 inch cable with a mating connector is also available from CES. This cable significantly simplifies installation and allows for positive connection and disconnection.

DO NOT MAKE ANY CONNECTIONS UNTIL READING THE ENTIRE MANUAL. CONNECTIONS FOR RECEIVE AUDIO AND COR (CARRIER OPERATED RELAY) ARE ESPECIALLY IMPORTANT TO FULLY UNDERSTAND BEFORE SET UP .

The following tables show all required and optional connections:

CARD EDGE CONNECTOR

CONNECTOR PIN FUNCTION/CONNECTION

- 1 +12 VDC / power supply +
- 2 Telephone Interconnect PTT (option)
- 3 TX CTCSS Tone / to transmitter if used
- 4 Receive audio / receiver discriminator *
- 5 -COR- / negative going COR *1
- 6 Key - no connection
- 7 Remote Tx Disable (optional - ground to disable)
- 8 Transmit Audio / to TX microphone high
- 9 Telephone Interconnect Tx Audio (option)
- 10 Telephone Interconnect Rx Audio (option)
- 11 +COR+ / positive going COR *1
- 12 PTT / Transmitter PTT
- 13 PTT Relay Normally Closed (not used)
- 14 PTT Ground / Transmitter Ground

14 PTT Ground / Transmitter Ground

15 Auxiliary Relay Common

16 Auxiliary Relay Normally Closed

17 Auxiliary Relay Normally Open

18 Ground / Power Supply Ground

OPTIONAL CABLE CONNECTIONS

CABLE WIRE COLOR CONNECTION/FUNCTION

WHITE BAND Shield Receiver Ground

RECEIVER Green Receiver or Discriminator Audio *

Brown COR-(neg.) *I

Orange COR+(pos.) *I

Red +12 VDC

RED BAND Shield Transmitter Ground

TRANSMITTER Yellow Tx Audio

Orange CTCSS Tone (if deck is installed only)

Brown PTT

Black PTT Ground

* Receiver or Discriminator Audio: The receiver audio connections should be made directly to the discriminator output of the receiver before any filtering if possible. If the COR connection is not made (see **I COR), discriminator audio must be used. Also, if the receive audio connection is made to other than the discriminator, capacitor C11 should be removed from the board to defeat the audio de-emphasis built into the Repeater Maker. (see layout drawing).

** Carrier Operated Relay: COR connection is not mandatory (see above) but is suggested if a COR signal is available in the receiver.

Only one of the COR connections is to be used. If the COR goes high when a received signal is present connect the +COR+. If the COR goes low (ground) when a received signal is present connect the -COR-. Negative going COR must go from greater than 2.5 volts DC to less than 1.5 volts DC. Positive going COR must go from less than 0.7 volts DC to greater than 1.5 volts DC.

JUMPER PLUGS OR WIRE JUMPERS: Several functions or operational parameters are controlled by jumper plugs or wire jumpers. See the assembly drawing for jumper locations. The jumper programming is shown in the following table:

JUMPER FUNCTION AND INSTRUCTION

JP1 CTCSS - without CTCSS deck installed - IN

with CTCSS deck installed - OUT

JP2 CTCSS - No Tx Tone on repeater hang-time - IN

Tx Tone on repeater hang-Time - OUT

(leave in if no tone deck)

JP3 PATCH - No telephone interconnect installed,

Normal - OUT

Telephone interconnect installed - IN

(disables repeat audio when patch PTT is

present)

JP4 REPEAT AUDIO - More gain on Repeat audio - IN

Less gain on Repeat audio - OUT

JP5 COURTESY BEEP - Beep enabled - IN

or ROGER BEEP - Beep disabled - OUT

JP6 COURTESY BEEP - Immediate when carrier drops - IN

or ROGER BEEP - Approx. 1 second delay - OUT

JP7 TX AUDIO LEVEL - For High Impedance - IN

For Low Impedance - OUT

JP10 CTCSS TONE FILTER - No CTCSS Tone Deck installed-IN

- CTCSS Tone Deck installed - OUT Connect wires from Tone Deck as shown in layout drawing.

CTCSS - refers to optional Model TS-32P Encoder/Decoder. If the TS-32P is used, install it as shown on the drawing, and program tone according to the chart in the back of this manual.

Note:When using the TS-32P, if your application requires that both jumpers JUI and JU2 on the TS-32P to be connected, then JUI should be

replaced with a germanium diode. Place the diode so that the cathode goes to the collector of Q1 and the anode goes to the base of Q2

DO NOT CONNECT TONE OUTPUT, (E6) AND DO NOT REMOVE JP1 UNTIL AFTER THE REPEAT AUDIO LEVEL HAS BEEN SET LATER IN THE SETUP PROCEDURE.

SWITCHES:

S1 switch bank controls timers for Hang-Time and Time-Out Timer. Switch S3 selects COR source used. Switch functions and timing are shown in the table below:

SWITCH SETTINGS

X-ON 0 - OFF

S1 SECTIONS 1 THROUGH 3 CONTROL REPEATER TIME TIMER.

(TIMES ARE APPROXIMATE)

30 sec. 1 min. 2.5 min. 3 min.

1 2 3 1 2 3 1 2 3 1 2 3

x x x x x 0 x 0 x x 0 0

7.5 min. 9 min. 10 min.

1 2 3 1 2 3 1 2 3

0 x x 0 0 x 0 0 0

S1 SECTIONS 4 THROUGH 6 CONTROL REPEATER HANG TIME.

(TIMES ARE APPROXIMATE)

No Hang-Time 1 sec. 2 sec. 3 sec.

4 5 6 4 5 6 4 5 6 4 5 6

x x x x x 0 x 0 x x 0 0

4 sec. 5 sec. 6 sec.

4 5 6 4 5 6 4 5 6

0 x 0 0 0 x 0 0 0

S-3 SELECTS COR SOURCE.

A Position Repeater Maker COR (discriminator audio)

B Position External COR (radio's COR)

III. INSTALLATION:

Connections should be made with the power to all equipment disconnected.

+12 Volts, DC, POWER SUPPLY - PIN #1

Connect to a source of regulated, filtered, positive 12 volts DC. If separate power supplies are used for the transmitter and receiver units, the power source for the Repeater Maker should be the one used to power the receiver. This will lessen the chance of problems due to voltage fluctuations when the transmitter keys up or unkeys.

TELEPHONE INTERCONNECT PUSH TO TALK (option) - PIN #2

The Push To Talk lead from an Interconnect unit connects to this point if used.

TX CTCSS TONE/TO TRANSMITTER (if used) - PIN #3

If CTCSS is to be used on the repeater system and the optional TS-32 Encoder/Decoder board is installed, this connection must be made to a suitable tone injection point in the transmitter. Consult the manual and/or schematic for your transmitter for this connection.

RECEIVE AUDIO/RECEIVER DISCRIMINATOR - PIN #4

Connect this pin to the discriminator of the receiver. Discriminator audio is necessary for proper operation of the Repeater Maker's built in COR. If your receiver has a suitable COR output (see COR sections) you may connect the receiver audio to an audio stage after the squelch control in the receiver. This is discouraged since the receiver squelch control will control the repeater operation. If de-emphasized audio is used it is necessary to remove C11 from the board to defeat the internal de-emphasis in the Repeater Maker.

-COR-/NEGATIVE GOING COR - PIN #5

If the previous connection (pin #4) was made to Discriminator audio then COR connections are optional. COR sources in the receiver must be measured before making connections. Measure the DC voltage on the proposed source. If the voltage is greater than 2.5 VDC with the receiver squelched and it drops quickly to less than 1.5 VDC when the receiver is unsquelched it is suitable for connection to PIN #5. If the voltage does not meet the above parameters do not connect PIN # 5. If the voltage is less than 0.7 VDC with the receiver squelched and it quickly rises to greater than 1.5 VDC when unsquelched then the COR connection should be made to +COR+/PIN #11. If available COR sources do not fall within either of the above parameters no COR connection should be made. If this is the case the receive audio connection (previous step) MUST be made to the discriminator.

REMOTE TRANSMITTER DISABLE - PIN #7 (optional) Ground to disable transmitter.

TRANSMIT AUDIO - PIN #8

Connect to transmitter Microphone High Input.

TELEPHONE INTERCONNECT TRANSMIT AUDIO - PIN #9 (option)

The Transmit Audio lead from a telephone Interconnect unit is connected to this point if used.

TELEPHONE INTERCONNECT RECEIVE AUDIO - PIN #10 (option)

The Receive Audio lead from an interconnect unit is connected to this point if used.

+COR+/POSITIVE GOING COR - PIN #11

SEE CONNECTION INSTRUCTIONS FOR -COR- PIN #5 (above)

PTT /TRANSMITTER PUSH TO TALK - PIN #12

Connect a wire from this pin to the Push To Talk line of the Transmitter. Usually this is connected at microphone PTT.

NO CONNECTION IS MADE TO PIN #13

PTT GROUND - PIN #14

Most transmitters use ground for transmitter keying. In this case PIN #14 is connected to the transmitter's ground. Some radios require positive voltage for keying the transmitter. In this case PIN #14 should be connected to that voltage source in the transmitter.

AUXILIARY RELAY COMMON - PIN #15 (optional)

AUXILIARY RELAY NORMALLY CLOSED - PIN #16 (optional)

AUXILIARY RELAY NORMALLY OPEN - PIN 817 (optional)

This is a spare set of relay contacts that works with the push to talk of the Repeater Maker.

GROUND/POWER SUPPLY GROUND - PIN #1 8

Connect a wire from this point to the power supply negative or receiver ground. It is recommended that both radio and the RM-10 have their grounds (and/or chassis) connected together.

IV. ADJUSTMENT AND TESTING: ALL TESTING SHOULD BE DONE WITH THE TRANSMITTER CONNECTED TO A SUITABLE DUMMY LOAD.

COR THRESHOLD:

This adjustment is made if the receive audio is connected to the discriminator and the internal COR in the Repeater Maker is being used. (check S3). Disable the transmitter via the TX Disable switch on the front panel of the Repeater Maker. Turn on the power supply and radio. Observe the COR LED and turn the COR Threshold control (R5) until the LED goes on. Turn the control back until the LED just goes off. The COR is now set correctly.

If the COR of the receiver is being used instead of the Repeater Maker then this adjustment is made by setting the squelch control on the radio to threshold.

REPEAT AUDIO:

Inject a strong (10uV) on frequency signal modulated with 1 KHz tone at 4 KHz deviation into the receiver. Set the Repeat Audio control (R8) at approximately the midpoint of its range. Enable the transmitter (front panel switch) and adjust the Repeat Audio control for 4 KHz deviation measured with a deviation meter on the transmitter output. If it is difficult to obtain a 4 KHz output jumpers may have to be removed as follows: If deviation is above 4 KHz and the control is at minimum then remove JP4 and readjust. If deviation is below 4 KHz and the control is at maximum then remove JP7 and readjust.

COURTESY BEEP or ROGER BEEP: (if enabled)

Apply and remove the signal from the receiver and listen for the courtesy beep. If adjustment is needed, repeatedly inject a signal into the receiver and remove it to activate the beep. Adjust the BEEP control (R33) between beeps until the desired level is obtained.

CTCSS (if used):

With power removed from the RM-10, remove JP10 (wire jumper) and install the TS-32 as shown in the layout drawing. Program the desired CTCSS tone according to the chart on the following page. Remove JP1 to enable CTCSS tone decode function. Only signals modulated with the proper CTCSS tone will be repeated. Make sure all connections have been made properly and power up the RM-10 and radios.

Inject an on frequency signal modulated with the proper CTCSS tone into the receiver. The transmitter will turn on as long as the correct tone is present. Observe the transmitter output deviation and set the tone output level.

TELEPHONE INTERCONNECTS: Follow normal installation procedure for the Interconnect unit except that connections are to be made to the appropriate inputs and outputs of the Repeater Maker instead of the radio. JP3 should be in place for interconnect use to disable repeat audio when the Interconnect PTT is present.

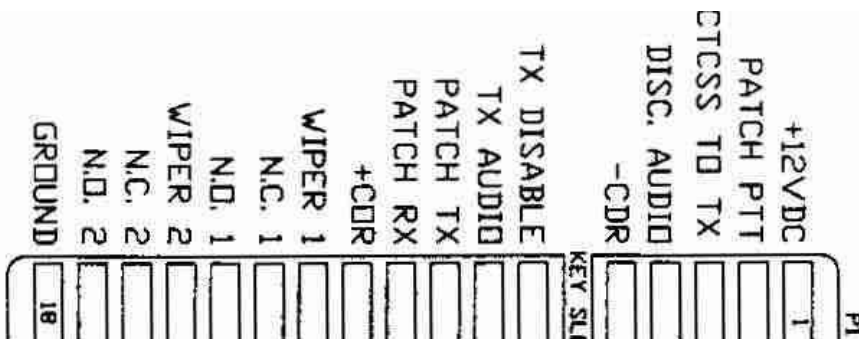

* MODEL TS-32 ENCODER/DECODER NOT INCLUDED IN BASIC RM-10

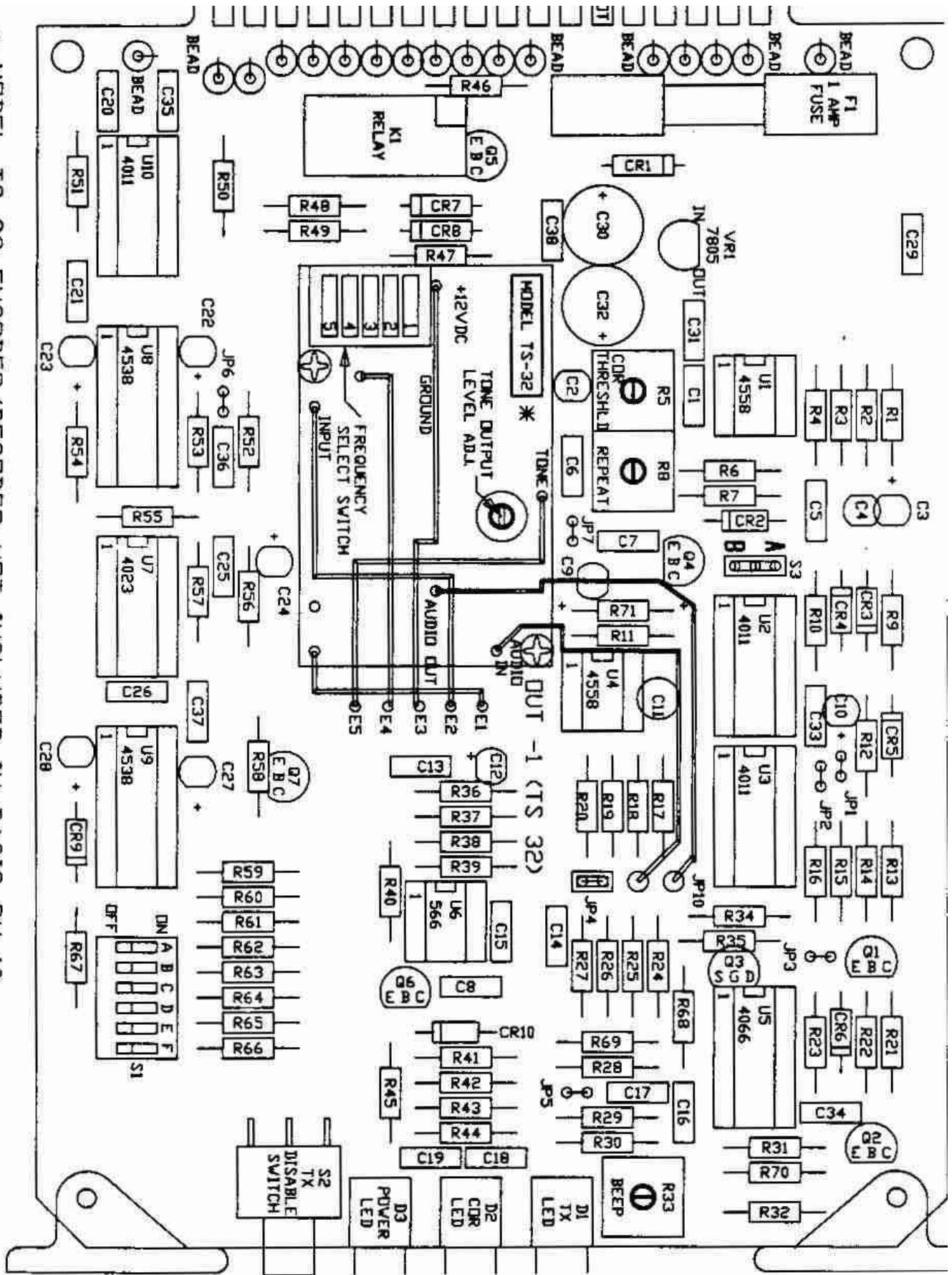

[Back To Product Manuals Main Page](#)

CES RM-10 Programing Info

Send mail to webmaster@ces.com with questions or comments about this web site.

This page last updated on 01/10/13

This site developed and maintained by [Qro-Tech Systems](#)