

HIGH EFFICIENCY BATTERY CHARGER USING POWER COMPONENTS⁽¹⁾

By Marco Panizza
Senior Application Engineer Vicor



TPB 101

INTRODUCTION

An offline battery charger — using the Unitrode UC3906 battery charger controller chip and a Vicor Maxi, Mini, Micro Series DC-DC converter module — provides design flexibility, small size, and high efficiency. The system is described, and an estimate of overall efficiency of the battery charger is derived.

A common method utilized in the proper care and feeding of lead-acid batteries recommends the use of a dual-level charging current: high current for the discharged state and a trickle current for the fully charged state. A 12 V lead-acid battery voltage can vary from below 10.5 V when deeply discharged to over 14.4 V while being charged; hence, the charger IC needs to control the DC-DC converter's voltage and current over this range. A key feature of Maxi, Mini, Micro Series DC-DC converters that makes them well suited for battery charging applications is their wide trim range from 10% to 110% of the nominal output voltage. This allows a 15 V output unit, for example, to be adjusted from 1.5 V to 16.5 V, well in excess of the range of interest.

A UNIQUE CONVERTER CONTROL SCHEME

All Vicor Maxi, Mini, Micro Series converters have a Secondary Control (SC) pin on the output that allows adjustment or trim of the output voltage. For the battery charging circuit, we will also exploit another feature: the +Sense pin is not internally connected to the +Out pin. Therefore, the output voltage can be varied by impressing a control voltage between +Out and +Sense. When the output voltage is trimmed down to the minimum required, V_{min} , the control voltage, V_c can be used to vary the output voltage in accordance with:

$$V_{out} = V_{min} + V_c \quad (1)$$

Figure 1 shows a simple circuit to accomplish this control. When Q2 is off, the voltage across R13 is zero and the output voltage is at its minimum value (V_{min}) as set by trim down resistor R1⁽²⁾. When Q2 starts conducting, a voltage will develop across R13 such that:

$$V_c = R13 * I \quad (2)$$

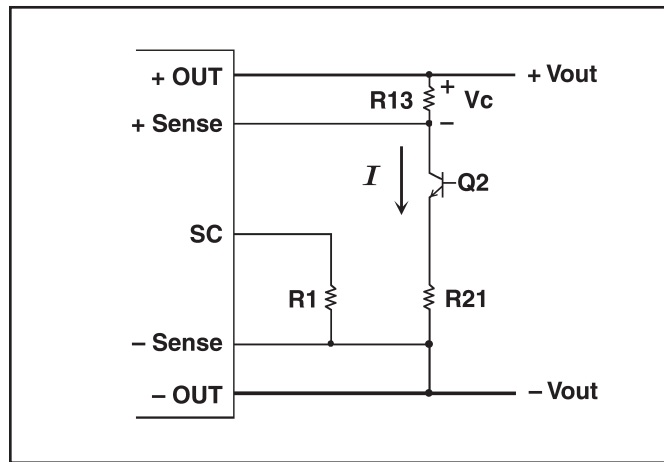

Figure 1. Converter control schematic

The output voltage will increase in accordance with (1). R21 acts as a limiter to ensure that, when Q2 is driven into saturation, the voltage across R13 will not cause the output to exceed its maximum rating. In the case where V_{min} is set to 50% of the nominal output, setting $R13 = R21$ (not including V_{CEsat} of Q2) will result in a V_{out} control range of 50 to 100% of the nominal output voltage of the converter.

THE UC3906 CONTROL CHIP⁽³⁾

The UC3906 is an integrated circuit specifically designed to implement dual-level charging for sealed lead-acid batteries. With the addition of a few external components, it is possible to select the appropriate charging algorithms based on the battery manufacturer's specified voltage and current thresholds and temperature characteristics.

The output of the UC3906 is intended to control an external pass transistor to linearly regulate the charging current and voltage. This is generally appropriate for small capacity battery systems but becomes extremely inefficient for large capacity battery systems. Using the output to drive the control voltage described above, however, results in a very high efficiency, high current charger.

LEAD-ACID BATTERIES

Lead-acid cells have been called the “workhorse of the industry” because they have high-energy storage capacities and long standby and cycle lives. To get the most of their capabilities, however, it is very important that the charging method be carefully matched to the requirements of the manufacturer. (Errors in a float charger’s characteristics of just five percent, for example, can cut expected lifetime in half.)

A lead-acid battery manufacturer often recommends a charging process normally referred to as “dual-level charging”. A dual-level battery charger has three states: a high-current bulk charge state, an equalize charge state, and a float charge state.

A completely discharged battery will be first charged by applying a large current. During this phase, the lead sulfate (PbSO_4) will be converted into metallic lead on the negative plates and lead dioxide on the positive plates. Once most of the lead sulfate is converted, the battery begins an overcharge reaction. At this point, the charging current must be drastically reduced to avoid excessive development of gasses that will dehydrate the battery or cause a sealed lead-acid battery to vent. At the end of the controlled equalize charge cycle, to keep the battery fully charged and ready for use in stand-by mode, the charger will stay in the float charge condition. The charge process will restart when the battery voltage drops below a certain discharge threshold.

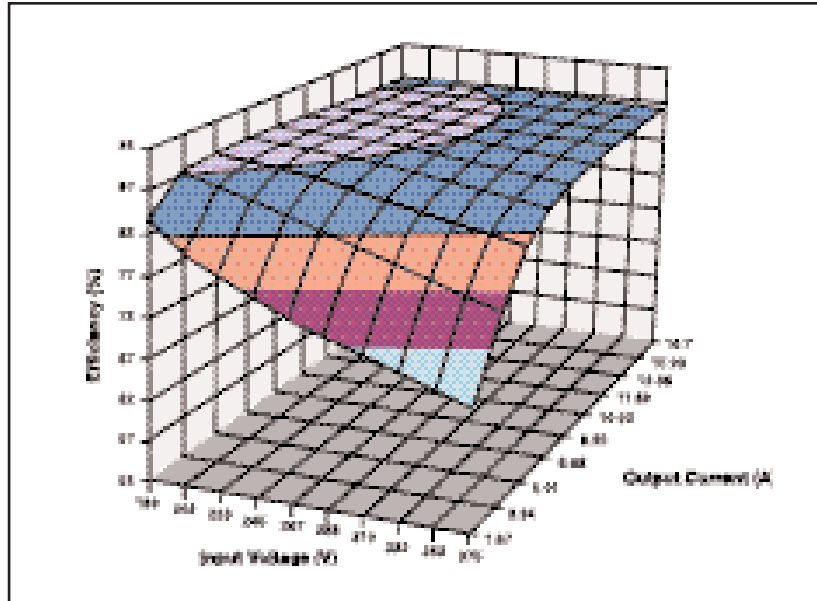

Figure 2. Efficiency versus input voltage and output load

THE BULK POWER ELEMENT

A switch-mode DC-DC converter (with a front-end module) used as the bulk power element can regulate the output power much more efficiently than a linear regulated power supply — and it is smaller. In particular, the quasi-resonant, zero-current switching topology of Vicor DC-DC converters switches the MOSFET at zero current, which minimizes switching power losses and enhances efficiency. Figure 2 shows a surface representing efficiency versus input voltage and output load that is relatively constant over a wide operating range.

Modular power components simplify the design of a switch-mode converter, eliminating steps such as choosing the magnetic parts or performing feedback loop and compensation calculations. With their wide selection of models, covering every input and output voltage range and power level, Vicor building-block modules can — with a few discrete components — be used to implement a complete switching power supply. If input / output power characteristics change, the converter can be replaced by another one with no need for modifications.

THE COMPLETE BATTERY CHARGER

The complete schematic for a 12 V/15 V battery charger is shown in Figure 3. The converter’s control scheme can be identified by the following components: pins 16 and 15 of the UC3906 are the collector and emitter of the pass transistor, resistors R13 and R21 comprise the voltage divider for controlling the voltage on the +Sense pin, and R1 sets the output voltage of the DC-DC converter to 50% of V_{OUT} nom. Resistors R13 and R21 have the same value in order to bring the output up to the nominal value during full saturation of the transistor.

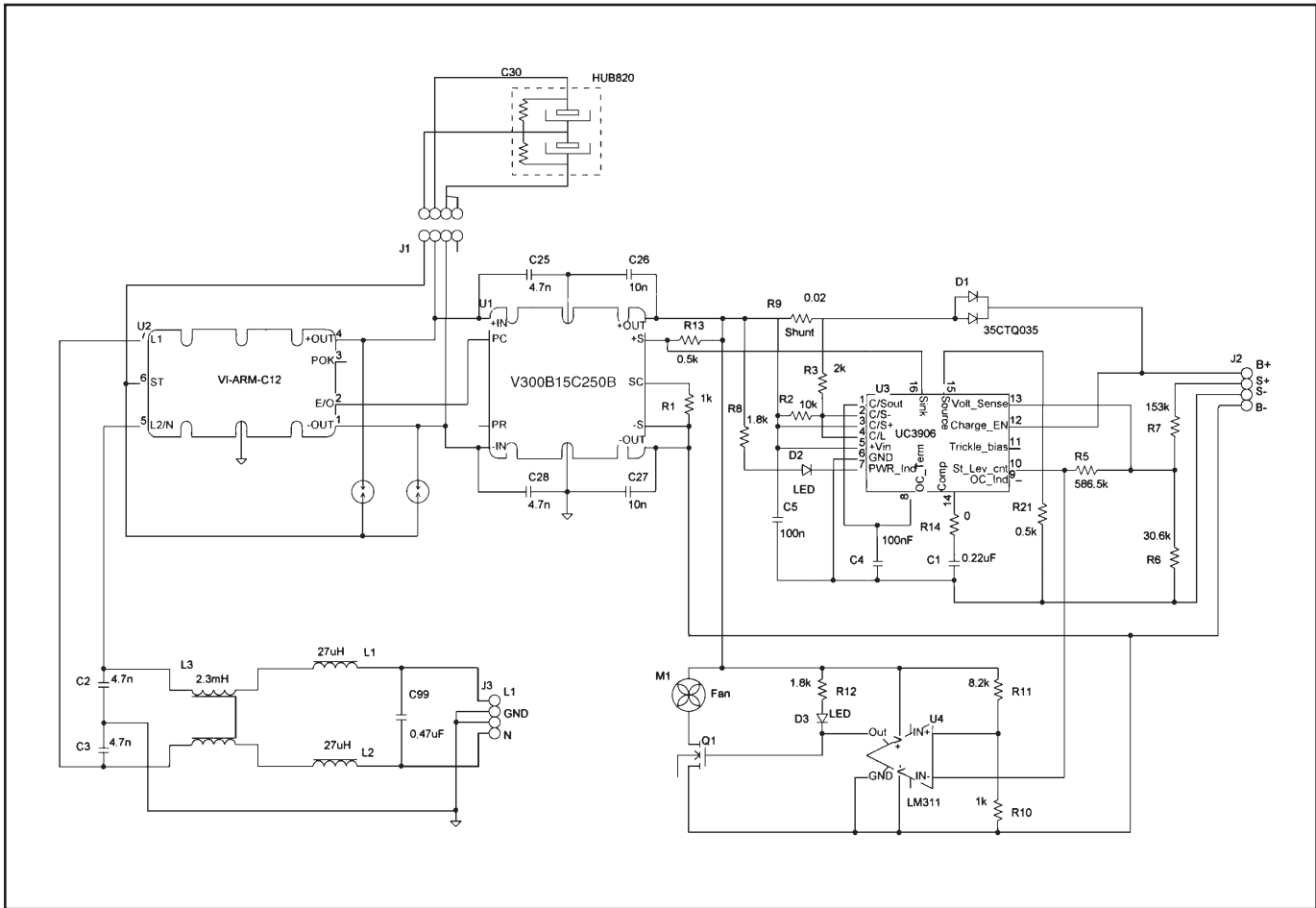

Figure 3. High-efficiency battery charger schematic

The DC-DC converter is chosen with a standard 15 V output which gives enough margin to accomplish the overcharge phase, typically bringing the battery voltage to 14.4 V (equalize voltage). The minimum output voltage can be set to any value by changing R1, although 7.5 V is typically below the limit (Low Voltage Cutoff) reached by a deep discharge. The current limit value is fixed by the shunt resistor R9 and the divider R2 and R3.

With the values for R13 and R21 as indicated, the maximum current that flows through the pass transistor of U3 is limited at 10 mA. This keeps power dissipation on the transistor low to avoid excessive heating of the IC which would affect the precision of the internal voltage reference. Diode D1 decouples the battery from the DC-DC converter and the controller, eliminating self discharge due to bias currents when the charger is in the float condition.

The comparator U4 is used to indicate when the battery is fully charged. When the UC3906 goes into the float charge state, pin 10, Status Level Control, goes high, setting the output of U4 low and turning LED D3 on. At the same time, the MOSFET Q1 will switch off and the cooling fan will stop. In the float charge state, the power demand from the DC-DC converter is almost zero because there is a minimal charging current, negating the need for forced air cooling.

The module VI-ARM-C12, together with the capacitors of the HUB (Hold Up Box) implement the AC-DC conversion section. VI-ARM is a complete AC rectifier with in-rush current limit and autoranging function for operation at 115Vac or 230Vac. The inductor group L1, L2, L3 together with the capacitor group C2, C3, and C99 form an input EMI filter to reduce line-conducted emissions.

EFFICIENCY ESTIMATION

The components with significant power dissipation in this system are the DC-DC converter module, the Schottky diode D1, and the shunt resistor R9. In this derivation of an estimate of system efficiency, other sources of power dissipation will be neglected.

At the end of the over-charge phase, the output power to the battery will be:

$$P_{\text{out}} = V_{\text{oc}} * I_{\text{M}} = 14.4 * 15 = 216 \text{ W}$$

The power dissipated on D1 is:

$$P_{\text{D1}} = V_{\text{f}} * I_{\text{M}} = 0.4 * 15 = 6 \text{ W}$$

The power on the shunt R9 is:

$$P_{\text{R9}} = R * I^2 = 0.02 * 15^2 = 4.5 \text{ W}$$

Therefore, the output power from the DC-DC converter is:

$$P_{\text{outDC-DC}} = P_{\text{out}} + P_{\text{D1}} + P_{\text{R9}} = 226.5 \text{ W}$$

Considering a worst-case efficiency of 85% for the DC-DC converter, the input power will be:

$$P_{\text{in}} = \frac{P_{\text{outDC-DC}}}{\text{Efficiency}} = \frac{226.5}{.85} = 266.5 \text{ W}$$

Neglecting the power losses associated with the input EMI filter, the VI-ARM and the UC3906, the overall efficiency of the battery charger is:

$$\text{Eff}_{\text{tot}} = \frac{P_{\text{out}}}{P_{\text{in}}} = \frac{216}{266.5} = 0.81 = 81\%$$

The worst case efficiency is at the beginning of the charging phase, when the battery is fully discharged. In this case, the output power is reduced but the losses on the diode and the shunt are constant because they depend

on the output current. Also, it should be noted that the battery usually recovers quickly during this bulk charge phase minimizing the amount of time spent at this lower efficiency.

At deep discharge with 7.5 V output, the numbers change as follows:

$$P_{\text{out}} = V_{\text{out}} * I_{\text{M}} = 7.5 * 15 = 112.5 \text{ W}$$

$$P_{\text{outDC-DC}} = P_{\text{out}} + P_{\text{D1}} + P_{\text{R9}} = 123 \text{ W}$$

$$P_{\text{in}} = \frac{P_{\text{outDC-DC}}}{\text{Efficiency}} = \frac{123}{.85} = 144.7 \text{ W}$$

$$\text{Eff}_{\text{tot}} = \frac{P_{\text{out}}}{P_{\text{in}}} = \frac{112.5}{144.7} = 0.777 = 77.7\%$$

SUMMARY

The use of a sophisticated integrated circuit that controls and optimizes the charging process of lead-acid batteries, together with high efficiency / high power density DC-DC converter modules, provides flexibility in the implementation of reliable battery charger systems. Such designs offer the advantages of reduced volume and lower power dissipation as well.

These designs maximize battery operating life and minimize the cost of maintaining large battery banks, such as those for UPS systems or electric vehicles. The availability of a broad choice of modular DC-DC converters provide the flexibility needed to adapt the battery charger for every input voltage range, battery voltage, and capacity.

- ¹ This article was originally published in DESIGN & ELEKTRONIK, 6th Development Forum "Batteries, Charging Concepts & Power Supplies: design 99" held on 30th March 1999 in Munich. This edited version is published with permission.
- ² Calculators for determining the value of trimming resistors are available on the Vicor website: vicorpower.com.
- ³ A detailed description of the UC 3906, together with calculation details, can be found in the Unitrode Application Note U-104, which is available on the Vicor website at vicorpower.com or on the Unitrode website at unitrode.com/apps/apps_pub.htm.