

Note from WA6ILQ:

This article was emailed to me without attribution. I did a bit of research and discovered it's by Tony King W4ZT (SK)

## Astron Power Supply Meter Modification



Both meters were stuck up scale and totally useless. This is how I fixed the problem. This isn't a construction article. If you decide to modify your supply you may have to do things differently or use different parts. The meters I used came from [Marlin P. Jones \(http://www.mpja.com/\)](http://www.mpja.com/) and were part number 12306 ME.



I completely remove the panel and then measured, marked and enlarged the holes.



This is the meter power board mounted in using existing holes in the bottom of the supply.



The meter power board. It has a 7805 regulator to provide +5 volts for the voltmeter and an NE555 oscillator inverter to provide an isolated +5 volts for the ammeter. This is built on a piece of prototype board and the schematic is at the bottom of this page.



Back view of the voltmeter.



Back view of the ammeter showing the connection to the emitter resistor and the 5k (measured 4.8k) potentiometer which parallels the 0.05 ohm emitter resistor. The CCW lead connects to Ground on the meter and to the output voltage end of the emitter resistor. The Arm connects to  $V_{in}$  and the CW lead connects to the end of the 0.05 ohm emitter resistor nearest the emitter connection.



Close-up of the 5k pot used to adjust the voltage to the ammeter. The ammeter is set up as a 200 mv meter and then calibrated using the 5k pot to read properly.



Ammeter



Voltmeter



This is a 2.2k 1/2 watt resistor in series with an LED between the positive and negative of the filter capacitors providing a low current bleeder and indicator when there is voltage in the supply. Without a bleeder, the capacitors will retain a charge for a very long time. After all, there's 100,000 uf there!

Schematic of the power supplies for the Digital Panel Meters. Note that the ammeter must have a floating supply to function properly. Click this small schematic to open a larger one in a separate browser window.

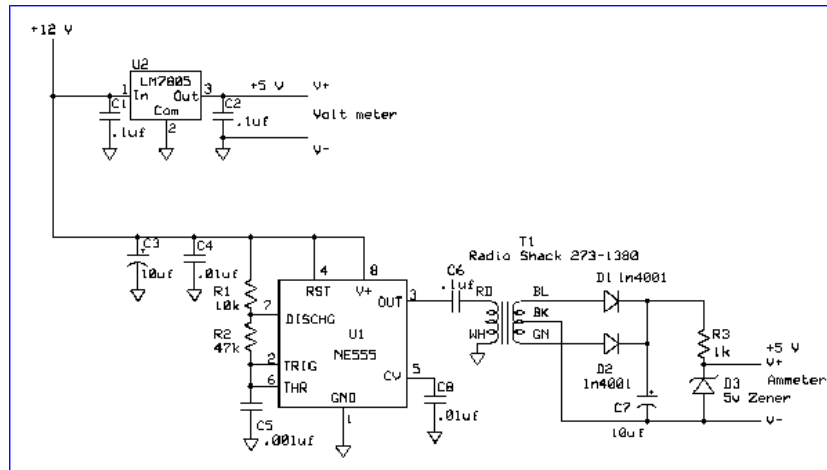

On 09/12/2005 I corrected the schematic to reflect NO ground on the ammeter supply.

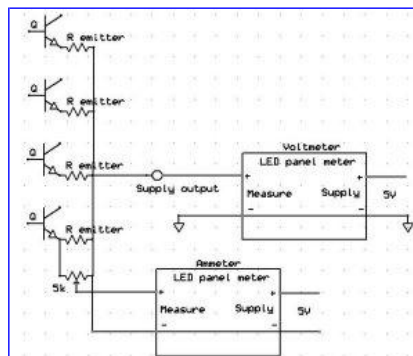

This isn't meant to be a construction article. It's just my way of sharing what I've done. I'll try to answer your questions but there aren't any step by step instructions to go with this.