



INTERFERENCE TECHNICAL APPENDIX

This document provides additional information to the “Best Practices Guide”. It is provided to aid technical evaluation of interference situations and to provide recommendations on how to proactively prevent interference. Comments on how to improve or add additional information to this document are welcomed.

cara33@email.mot.com

TABLE OF CONTENTS

1.0	Introduction.....	1
2.0	Background	1
2.1	Band Structure.....	1
2.2	Hardware History.....	5
3.0	Interference Mechanisms.....	6
4.0	Effective Receiver SENSITIVITY	7
4.1	Receiver Interference Measurement Theory.....	8
4.1.1	Receiver Overload.....	8
5.0	Receiver Desensitization.....	9
6.0	Receiver Blocking.....	10
7.0	Receiver Intermodulation	11
8.0	Receiver Spurious Responses.....	14
9.0	Determining the Source of Interference	15
9.1	Test Equipment Required.....	15
9.2	Evaluation Procedure for Interference to Subscriber Units	15
10.0	Interference Versus Noise Limited Systems	20
11.0	800 MHz Band Example Interference Scenarios	21
11.1	Scenarios.....	22
11.2	Case 1a, LMR Base to LMR Subscriber	24
11.3	Case 1b, iDEN Site to LMR Subscribers.....	26
11.4	Case 1c, Cellular Carrier to Public Safety Subscriber.....	27
11.5	Case 2 LMR Base to Cellular Phone.....	29
11.6	Case 3, Cellular Base to 900 MHz Base	29
11.7	Case 4, LMR Base to Cellular Base.....	31
11.8	Case 5, Cellular Subscriber to LMR Subscriber.....	33
11.9	Case 6, Subscriber to LMR Base	34
12.0	SITE ISOLATION	36
12.1	Definition.....	36
12.2	Down-tilt Antennas.....	38
12.3	Site Photographs	40
13.0	Resolving interference.....	43
13.1	Recommended Resolution Process:	43
13.2	Methods to Reduce Interference of Specific Types.....	43
13.2.1	Possible actions to reduce the effects of transmitter sideband noise.	43
13.2.2	Possible Actions To Reduce The Effects Of Portable Receiver IM	44
13.2.3	Possible Actions To Reduce The Possibility Of Interference In The Future	44
13.3	Interference reduction methods.....	45
13.3.1	Change Frequency Pairs.....	45
13.3.2	Reduce ERP Or Signal Strength Of The Undesired Signal.....	45
13.3.3	Increase ERP Or Signal Strength Of Desired Signal	47
13.3.4	Long Term Avoidance	48
14.0	Acronyms	49

Table of Figures

Figure 1 - 450 MHz Band	2
Figure 2 - 800 MHz Band	3
Figure 3 - Recent 800 MHz Band Allocations	3
Figure 4 - Near - Far Scenarios	4
Figure 5 - Receiver Desensitization Measurement	8
Figure 6 - Typical Receiver	8
Figure 7 - Receiver Desensitization	10
Figure 8 - Receiver Blocking	11
Figure 9 - Receiver IM Above Reference Sensitivity	12
Figure 10 - IMR Performance	13
Figure 11 - Typical Receiver With A Wide Preselector Passband	14
Figure 12 - Initial Evaluation	15
Figure 13 - Evaluation With Spectrum Analyzer	16
Figure 14 - RF Noise Measurement Setup	17
Figure 15 - Noise Appearance	17
Figure 16 - Intermodulation Test	18
Figure 17 - Sideband Noise Determination	19
Figure 18 - 800 MHz Band, Interference Scenarios	21
Figure 19 - Case 1a, LMR Base to LMR Subscriber	24
Figure 20 - Intermodulation Example	25
Figure 21 - Case 1b, SMR iDEN Site to LMR Subscriber	26
Figure 22 - Case 1c, Cellular Carrier Base to Public Safety Subscriber	27
Figure 23 - Base-to-Mobile and Mobile-to-Mobile Interference Pattern	28
Figure 24 - Case 2, LMR Base Station to Cellular Phone	29
Figure 25 - Case 3, Cellular Transmitters to 900 MHz Base Receivers	30
Figure 26 - Case 4, LMR Base to Cellular Base	31
Figure 27 - Typical Motorola iDEN Base Station Internal Bandpass Filter	32
Figure 28 - Case 5, Cellular Subscriber to LMR Subscriber	33
Figure 29 - Case 6a, LMR Subscriber to LMR Base	34
Figure 30 - Case 6b, Cellular Subscriber to LMR Base	35
Figure 31 - Co-Located Cellular System and LMR System	35
Figure 32 - Example of Site Isolation Components	37
Figure 33 - Base Station, Omni-directional and Directional, Antenna Pattern Examples	37
Figure 34 - Worst Case Site Isolation Vs. Tower Height	38
Figure 35 - 10 dB Omni-directional Antenna Site Isolation	39
Figure 36 - 12 dBd Directional Antenna Site Isolation	39
Figure 37 - 40 Ft Tower with Down Tilted Directional Antennas	40
Figure 38 - Directional Antennas On One Story Building	41
Figure 39 - Adjacent Building. Down Tilt Antennas	41
Figure 40 - Directional Antenna Site on Power Pole	42

Table of Tables

Table 1 - 1980 Era Radio Frequency Limitations	6
Table 2 - Spurious Response Formulas	14
Table 3 - Differences between Noise and Interference Limited Systems	20
Table 4 - Generic Interference Scenarios	22

INTERFERENCE TECHNICAL APPENDIX

1.0 INTRODUCTION

This paper is intended for technical personnel. Although many issues are covered at a high level, a true understanding of the issues requires knowledge of test equipment and radio theory.

With the advent of cellular type system deployments in the 800 MHz band and the future 700 MHz band, LMR (Land Mobile Radio) system operators are faced with having to create highly reliable communications for noise limited systems while interference-limited systems are interspersed in the design service area. At this time users are seeing an increasing number of subscriber coverage holes when the LMR radios are in close proximity to high density SMR or cellular base station sites. As more and more radio systems are fielded with varying channel bandwidths and different types of modulation, the prevention, identification and remediation of interference is increasingly important.

- With the newer digital radio systems, interference is often reported as a loss of coverage or no coverage in areas where good coverage was predicted.
- With analog radios, the interference often audibly manifests itself, making the identification somewhat easier.
- Interference can be intermittent or constant. Intermittent interference is more difficult to identify and remedy due to its inconsistent appearance.
- Trunking systems make this more difficult as often interference is for a specific channel and that channel may or may not be assigned while the interference mechanism is active. When the trunking system's control channel is interfered with, system access and Grade of Service on alternate system resources may be affected.
- For data systems, interference from other systems may cause increased loading and response times due to the additional retries, this can affect subscriber roaming.
- The introduction of new radio systems in an existing coverage area may cause a critical point to be reached and suddenly cause degradation of system performance or complete loss of coverage in specific areas.

The purpose of this document is to sensitize system designers and maintenance personnel to these issues. First, there is a review of how the history of various band plans and hardware changes have increased the probability of interference. Next, the various mechanisms that can produce interference are defined. Common scenarios are provided to aid in identification of interference. The document closes with recommendations of hardware, procedures and actions that can greatly reduce the probability of interference both initially and in the future.

2.0 BACKGROUND

2.1 LMR Band Structures

In the very early days of Land Mobile Radio there was only Low Band (25 - 50 MHz) followed later by High Band (132 - 174 MHz). The use of mobile relay (repeater) operation was quite restricted in low band, and simplex operation was the most common configuration. Simplex operation creates a higher potential for base station to base station interference, even with large physical separation. To prevent this type of interference, many systems went to two-frequency simplex, transmitting on one frequency while receiving on a second frequency. This minimizes the base-to-base interference, but prevents mobile units from being able to monitor the channel for activity prior to transmitting. This requires a highly disciplined system, as a dispatcher is the only one that can relay messages between mobile units. Unfortunately, because the mobile units can't monitor the channel before transmitting, they cause intra system interference when more than one radio at a time contends for the channel.

High band operation had more opportunities for mobile relay operation. Unfortunately the band wasn't developed in a standardized fashion. Over time this resulted in mobile relay operation with some systems using reversed frequency plans relative to the other systems. This mixed with various combinations of "close and wide spaced" mobile relay configurations made frequency coordination and interference prevention a difficult process. In fact, before the introduction of the higher frequency bands, much of the system engineering involved designing sites to accommodate the nearly incompatible frequencies and configurations.

The UHF, 450 - 470 MHz, band was an opportunity to organize the new spectrum and prevent many of the problems systemic to the older bands. However at that time the state of the art for mobile and portable transmitter bandwidth was around 6 MHz. So it was decided to organize the band in such a manner that mobile relay systems would be quite common and that mobile radios could switch to the base station transmit frequency and talk directly to another mobile radio in close proximity (talk-around). This allows radios that are out of range of the repeater to still communicate in a simplex mode on the base station talk-out frequency. The protocol was quite simple. The first mobile to transmit would simply switch to the talk-around mode and transmit. The other mobile was already monitoring the correct frequency so the initiating mobile would simply tell the receiving mobile to switch to talk-around. Once accomplished, users could communicate in a simplex mode. No matter what users did, they were always monitoring the base talk-out frequency.

To facilitate this, the band was organized into four 5 MHz blocks with three interfaces between base transmitters and mobile transmitters. Figure 1 shows how the band was organized.

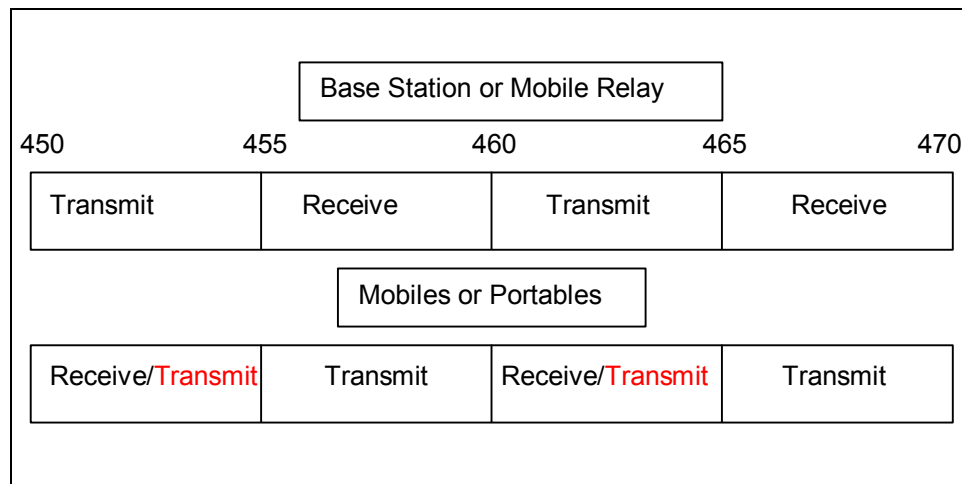

Figure 1 - 450 MHz Band

Later the UHF band was expanded to include sharing with UHF TV channels 14 through 20 (470 MHz - 512 MHz) in the top 13 US markets. Initially, the top ten markets got 2 TV channels each while the next three received a single TV channel. There have been additional allocations for Public Safety in Los Angeles, and some Canadian border issues preclude deployment. See CFR 47 §90.303 for specifics. To handle the different blocks of spectrum, each TV channel's band was divided in half, with land mobile base transmitters on the low half and base receivers on the high half. As a result the transmitter to receiver spacing is only 3 MHz in this portion of the band.

The next band to be allocated was the "take back" of UHF TV channels 70 - 83. This created a large amount of spectrum for private land mobile systems and for the new cellular industry. Once again, lessons from the older bands were incorporated to minimize interference potential. Transmitter/Receiver spacing was standardized at 45 MHz. To minimize the cost of subscriber units, the band was inverted from the 450 MHz band with the subscriber units transmitting on the low portion of the band.

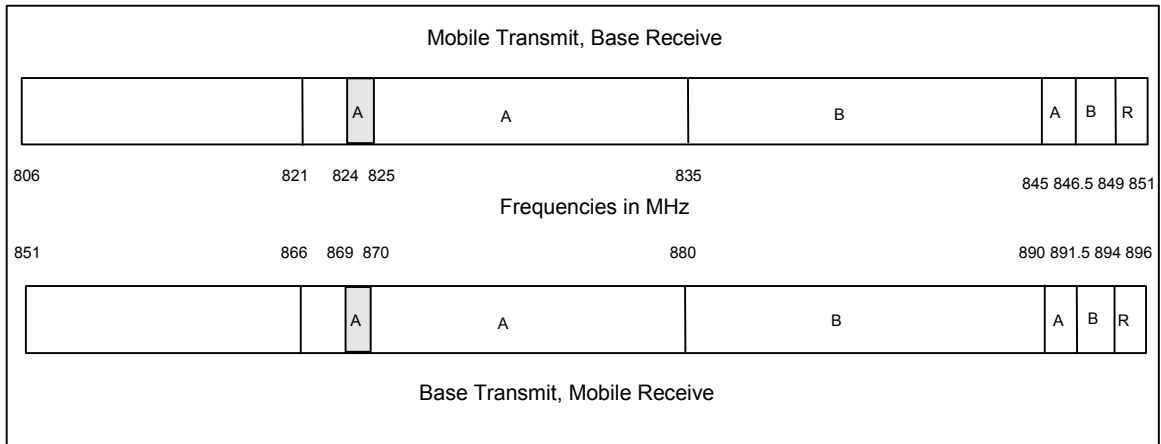

Figure 2 - 800 MHz Band

For trunked systems, channel assignments were made in blocks of up to five, with a constant 1 MHz separation between channels. This allowed for easy transmitter combining and minimizes some potential intermodulation. The cellular band was immediately adjacent to the land mobile band. Some reserve channels were held and later allocated to public safety and expansion of the cellular frequencies. It was the prolonged process of doling the channels out as opposed to assigning separate blocks that created the interleaved incompatible channel allocations.

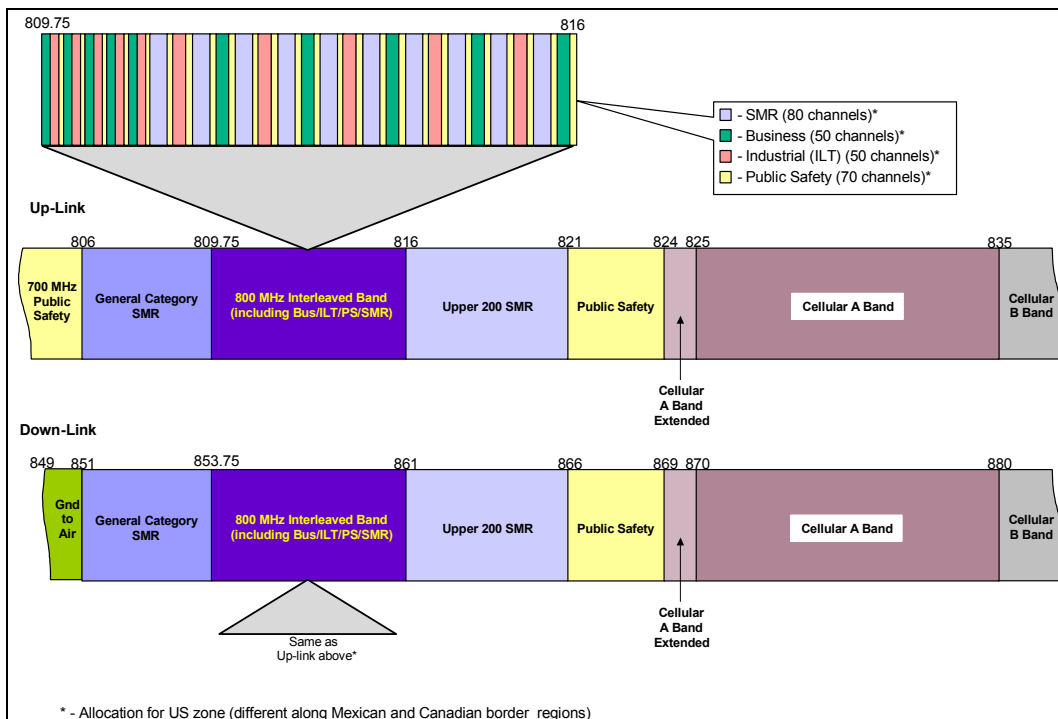

Figure 3 - Recent 800 MHz Band Allocations

Later, around 1988, additional 800 MHz channels were made available exclusively for Public Safety. These new frequencies are often referred to as “821 MHz” rather than the more accurate but complex name 821-824/866-869 MHz bands. Five interoperable channels were assigned on a national basis. At that time, narrow banding to 12.5 kHz channels was difficult and operability with the existing 800 MHz channels was a requirement, so a compromise solution was developed. The channels would be 25 kHz wide, but channel assignments would be granted every 12.5 kHz. Interference would be administratively controlled by a group of Regional Frequency Coordinators. The assumption is that a receiver would provide 20 dB ACIPR and this would be considered a requirement by the frequency coordinators, but not by the FCC. Co channel frequency reuse was generally based on a 35 dB C/I, but local regional frequency planning committees policies may alter this requirement slightly. Local planning committee recommendations must be adhered to.

The last block of frequencies allocated to private land mobile is in the 900 MHz band. This was the first real narrowband allocation. Channels are 12.5 kHz wide. This creates the potential for “near-far” interference scenarios.

The “near-far” situation has two different scenarios, as shown in Figure 4.

- A unit close (near) to a site on a nearby or adjacent undesired channel interferes with a weak (far) unit talking inbound on the desired channel.
- A unit far from its desired site is interfered with when close (near) to a nearby or adjacent undesired channel base station.

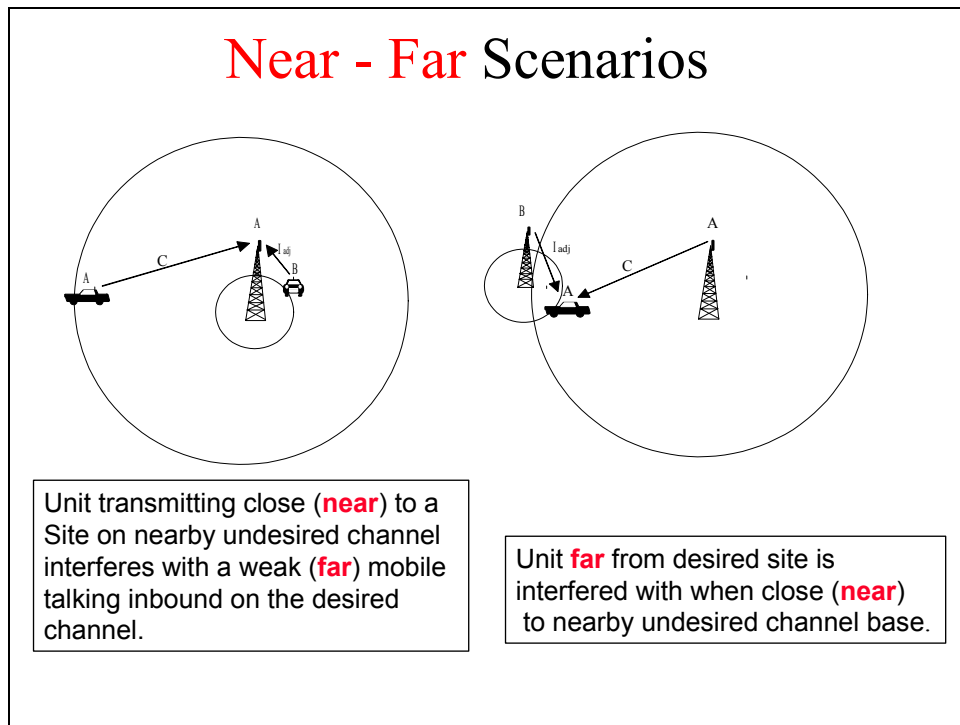

Figure 4 - Near - Far Scenarios

To compensate for this possibility, the channels were allocated in blocks of 10 adjacent channels. The concept was that any money spent to be a “good neighbor” should result in improved system performance for the person that spent the money. Thus this assignment policy created the situation where a user’s adjacent channel assignment belonged to themselves, except for the two end channels of a block. Over

time this assignment structure has changed due to channel swapping and FCC “take-backs” creating increased instances of interference due to the differing coverage areas and sites utilized. This has increased the occurrences of the near-far scenario.

Channels were assigned with a transmit to receive separation of 39 MHz with the same configuration as 800 MHz, base stations transmit on the high split, and mobiles transmit on the lower split. This minimizes the cost of power transistors for the subscriber units as they operate on the lower frequencies.

2.2 Hardware History

Older radios used crystals or channel elements to derive its transmit and local oscillator frequencies. As a result, if a radio had four-frequency capability, it required a total of eight crystals or channel elements to generate the correct frequency sources. This resulted in considerable cost and space being devoted for just the frequency generation.

Crystals are a very high Q component, ~50,000, so they generate a very clean response. To stabilize their performance, heated ovens were used to keep the crystals at a constant temperature. This was a considerable current drain, even in mobiles. As greater frequency stability was required the channel element became the preferred solution. A channel element is a crystal with a temperature compensating circuit that has been calibrated for that specific crystal, thereby eliminating the requirement for heating and its associated current drain.

The channel element eliminated the current drain that had been necessary to provide the temperature stability. However, they were still large and made radios quite large. The next step was to eliminate some of the channel elements by providing an offset oscillator for the receive frequency. In bands where a constant frequency difference from transmitter to receiver exists, one oscillator can be used for the specific transmit oscillator and offset it in frequency to become that pairs associated receiver local oscillator. When talk-around operation was needed, a second offset oscillator was optionally available. Thus a normal 4-frequency radio would have 4 channel elements and one offset oscillator. When equipped with Wide Space Transmit, it would have 4 channel elements and two offset oscillators. Note that the frequency stability was decreased by the additional frequency error of the offset oscillator.

The channel element size limitation allowed receivers to be designed with relatively narrow bandwidths. As a result, helical resonators were commonly used in receiver preselectors. They provided good front-end selectivity, which provided excellent protection from undesired signals and spurious responses. However the next step in providing increased frequency capabilities required more flexibility. This resulted in the replacement of the highly selective front-end with one with a greater bandwidth, resulting in increased interference potential.

The frequency synthesizer was introduced in the early 1980's. The frequency synthesizer is a lower Q device, and only requires a single channel element at its fundamental frequency. The instructions for the synthesizer to be able to generate the appropriate frequencies are stored in a memory module that could be a PROM or code-plug.

A frequency synthesizer costs more than separate channel elements until a critical number of channels is reached. Radios were introduced with more memory to hold the additional instructions and user interfaces were developed to allow the users to keep track of what channels they are on.

To be able to use the increased frequency capability, radios had to have increased bandwidth. Transmitters were widened, as were receivers. Some representative values from that era are shown below in Table 1.

Table 1 - 1980 Era Radio Frequency Limitations

Radio Type	Transmitter BW (MHz)	Receiver BW (MHz)
High Band Mocom 70	1, 2 w/ center tuned ¹	2
UHF Mocom 70	5	1
High Band Syntor	12	2
UHF Syntor	10	2
High Band Syntor X	24	24
800 MHz Syntor X	19	19
High Band MCX100	26/28 ²	4/12 ³
High Band MX300S	6	2
UHF MX300S	12	2

Current radios in the 800 MHz band have transmitter bandwidths in excess of 60 MHz and receiver bandwidths in excess of 18 MHz. The increased bandwidth for receivers with the resultant loss of pre-selector protection has increased the potential for various interference mechanisms.

3.0 INTERFERENCE MECHANISMS

There are a large number of different interference mechanisms that can cause a radio to have degraded performance. To properly determine the root cause or predominant mechanism, field measurements are normally required. By the proper introduction of a step attenuator and/or cavity filter in the receiver's lineup or cavities into the suspect transmitter's lineup, the effect can be measured and from that the root cause determined.

There are several important reference standards that should be considered in making measurements of interference. They are all published by the TIA/EIA:

1. ANSI/TIA/EIA-603-A "Land Mobile FM or PM Measurement and Performance Standards."
2. ANSI/TIA/EIA-102.CAAA, "Digital C4FM/CQPSK Transceiver Measurement Methods"
3. ANSI/TIA/EIA-102.CAAB, "Digital C4FM/CQPSK Transceiver Performance Recommendations."
4. TIA/EIA/TSB-88A, "Wireless Communications Systems – Performance in Noise and Interference-Limited Situations – Recommended Methods for Technology-Independent Modeling, Simulation, and Verification."

The following mechanisms are the most common and will be discussed as well as recommended methods of measurement.

- Receiver Desensitization
 - ACRR - Adjacent Channel Rejection Ratio
 - ACCPR - Adjacent Channel Coupled Power Ratio
 - ACIPR - Adjacent Channel Interference Power Ratio
 - Overload
 - Local Oscillator
 - Sideband Noise
 - Radiation
 - Spurious Responses
- Intermodulation (IM)
 - Receiver
 - Transmitter

¹ A special channel element was used to tune at the average frequency of the highest and lowest frequency.

² Low portion of band / high portion of the band

³ Dual front ends. Two at 4 MHz each, with up to 12 MHz separation.

- External
- Transmitter
 - Sideband Noise (adjacent/alternate channels)
 - OOB Emissions (>250% of channel bandwidth)
 - Spurious Emissions (Discrete frequencies)

4.0 EFFECTIVE RECEIVER SENSITIVITY

Receiver Desensitization occurs when a receiver requires higher signal levels to provide the same performance as when the interference source isn't present. The result is referred to as "Effective Receiver Sensitivity" as it determines what the sensitivity is in the presence of the interference mechanism and compares that to the sensitivity of a receiver when using only a signal generator, eliminating all external sources of interference. The difference between the Effective Sensitivity and the Normal Sensitivity is called Desensitization.

The Effective Receiver Sensitivity method of measurement is shown in Figure 5.

1. Measure and record the reference sensitivity of the receiver. The reference sensitivity is typically 12 dB SINAD for analog receivers or 5% static BER for digital receivers.
2. The receiver under test is connected to an "iso-tee" or directional coupler. Through the isolated leg, a signal generator is connected and the main input leg is terminated in the correct impedance (50Ω).
3. The receiver's reference sensitivity is again measured and recorded.
4. The termination is removed and the input port is connected to the normal external antenna system.
5. The signal generator is increased until the reference sensitivity is once again achieved and the value recorded.

The Effective Sensitivity is determined by determining the increase in required signal level to regain the performance provided at the reference sensitivity [Cs/N]. In this case the Cs/N is now Cs/(1+N).

$$\text{Effective Sensitivity} = \text{Direct Reference Sensitivity (Step 1)} + [\text{Sensitivity (Step 5)} - \text{Sensitivity (Step 3)}]$$

For example, if the direct reference sensitivity is -119 dBm and the value in steps 3 and 5 are -99 dBm and -80 dBm then the effective sensitivity is $-119 \text{ dBm} + (-80 - (-99)) = -100 \text{ dBm}$, or 19 dB of desensitization.

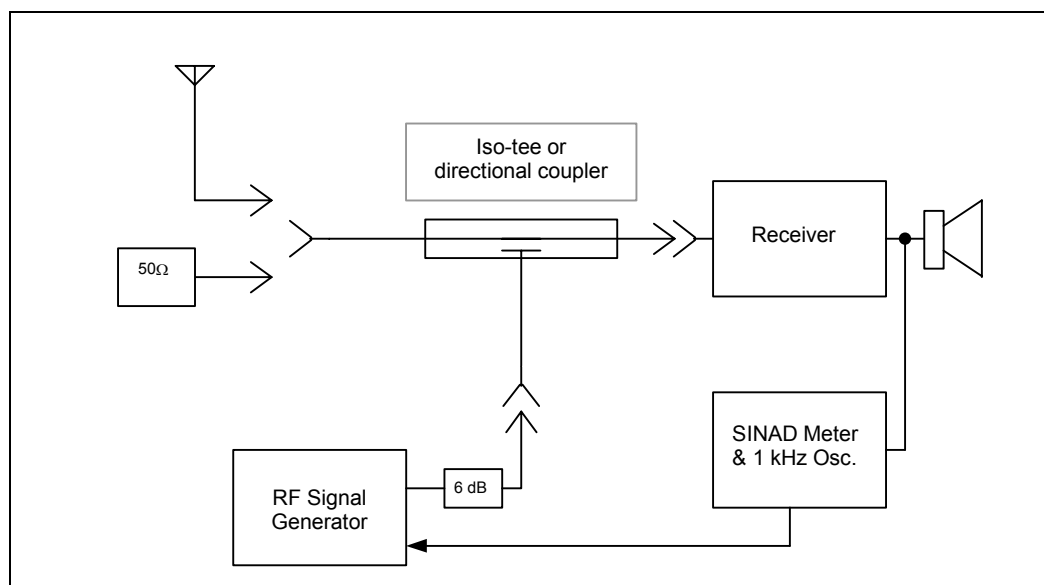

Figure 5 - Receiver Desensitization Measurement

It is important to note that the reference sensitivity is not a performance level for system design. The use of reference sensitivity is merely a method of determining the effective noise contribution by the interference mechanism. System designs require higher effective $C/(I+N)$ levels than does the reference C/N .

4.1 Receiver Interference Measurement Theory

Some receiver specifications are only valid when the desired signal is at reference sensitivity. When the desired is at this weak signal level, the receiver's internal noise floor becomes a way to measure the interfering signal's effect. It is commonly done by injecting a desired signal into a receiver at its reference sensitivity and then boosting the desired signal by 3 dB. The potential interference source(s) is introduced and increased in level so that the original reference sensitivity is regained. This is essentially causing the interference to produce the same effect as the thermal noise floor of the receiver. The two noise floors add up to 3 dB greater than the original noise floor. Then the effect of the mechanism is equivalent to the difference between the original reference sensitivity and the level of the interferer, it produces a noise like impact equivalent to the receiver's own noise floor.

As will be shown later, when the desired signal is considerably above the reference sensitivity, the 3 dB boost is no longer required. Knowing the reference sensitivity C/N is all that is required.

4.1.1 Receiver Overload

When a receiver is exposed to very strong signal levels, enough undesired energy can potentially force its way past the selectivity elements to cause limiters or AGC circuits to be activated. This reduces the available gain for the desired signal resulting in a loss of sensitivity. Figure 6 represents a "typical" receiver. It is general enough so it can be used for most of the receiver examples.

In this case, a strong signal passes easily through the preselector and is amplified and then down converted in frequency. The Intermediate Frequency Filters reduce the amplitude of the desired signal in addition to filtering the undesired signals. Typically it's amplified again and then filtered again. Some receivers have two Local Oscillators (LO). This is not always the case, but for the "typical" case it is included. When two Local Oscillators are being used, there is typically additional filtering at the second IF frequency. In most modern receivers, this filtering is done with Digital Signal Processors (DSP).

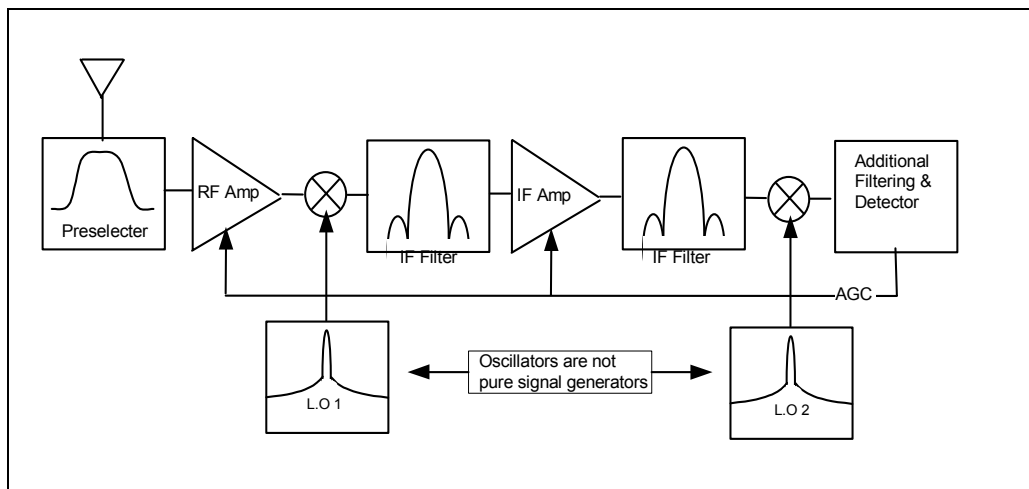

Figure 6 - Typical Receiver

5.0 RECEIVER DESENSITIZATION

Desensitization is the measure of a receiver's ability to reject signals that are offset from the desired signal's frequency. Desensitization of a desired signal at the reference sensitivity level due to an adjacent channel signal is defined as Adjacent Channel Rejection (ACR) in the ANSI/TIA/EIA-603-A and ANSI/TIA/EIA-102CAAA documents. The measurement procedure detailed in these documents for measuring ACR can be used to quantify receiver desensitization at any frequency offset and for higher desired signal levels. [Note that the TIA frequently uses a convention that produces a positive number for specified values. To accomplish this, they use ratios, always placing the largest value in the numerator and then adding an R to the end of the acronym. For example, ACR might be -75 dB, so ACRR would be 75 dB.]

There are several factors that may contribute to a receiver's desensitization characteristic. The receiver IF selectivity may be inadequate to reject strong signals, typically in excess of -50 dBm, on adjacent channels. Historically this has been a major factor determining the receiver's ability to reject strong signals on adjacent channels. With the availability of small and inexpensive ceramic filters and digital signal processing, it is less of an issue with modern equipment. However, interfering signal levels are commonly being measured in excess of - 50 dBm

Receiver LO sideband noise (note in Figure 6 that the LO spectrum is not a "pure" signal source) can heterodyne an undesired signal into the IF pass-band by mixing with a single high level signal, typically in excess of -50 dBm, and usually within 500 kHz of the desired signal. This mechanism is often confused with adjacent channel interference, and it is a contributing factor to the receiver's ability to reject strong signals on adjacent channels.

An additional consideration is the spectrum of the interfering signal. If the interfering signal has a broad spectrum, or a high OOB noise floor, the receiver desensitization measurement will indicate poor desensitization performance even for very well designed receivers. As receivers start utilizing very narrow IF bandwidths (12.5 kHz channel bandwidths or less) the effect due to the modulation components becomes more important. Previously analog (FM) receiver ACRR measurements only required a single 400 Hz tone at 60% of maximum system deviation. This no longer is considered applicable as it severely under estimates the amount of energy that the victim receiver can intercept from a modulated adjacent channel. Currently the TIA recommendations are undergoing changes that will require that the interfering source be modulated so it simulates the spectral energy distribution under actual operating conditions.

Figure 7 shows sensitivity level desensitization performance for a number of generic radios. Also compared in the figure are the desensitization levels due to different off-channel signal sources. One of the sources is a high performance signal generator, modulating a 400 Hz tone at ± 3 kHz deviation. The other source is an iDEN base radio transmitting iDEN Quad-QAM modulation.

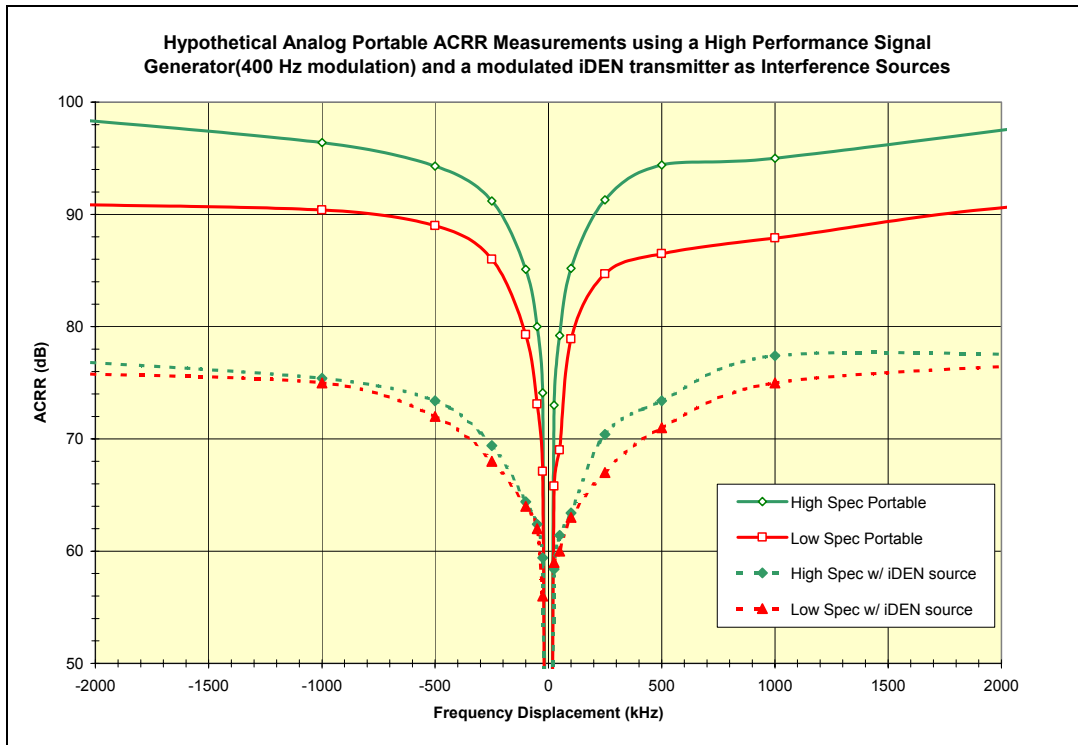

Figure 7 - Receiver Desensitization

Figure 7 shows that when a high performance signal generator is used as the interference source, receivers will typically have ≥ 90 dB rejection of signals that are offset ≥ 500 kHz from the desired channel. Receivers usually will have ≥ 80 dB rejection for offsets exceeding approximately 50 kHz. When an iDEN base radio is used as the interfering signal source, the ACRR desensitization level is approximately 20 dB less than when a high performance signal generator is used. This occurs due to the OOB noise of linear amplifiers. This indicates that high performance receiver designs may not realize improved desensitization performance because the performance is limited by an unfiltered base radio spectrum that contains high OOB (noise). There is a penalty for noise limited systems in the same or nearby bands where interference limited systems are deployed.

6.0 RECEIVER BLOCKING

Excessive desired on-channel signal levels can overload the receiver, usually the result of Automatic Gain Control (AGC) design limitations. The receiver front end can be overloaded by a single high level unwanted signal, not on the desired channel, typically in excess of -25 dBm, or multiple high-level unwanted signals whose total peak instantaneous power exceeds -25 dBm. These scenarios are also known as receiver blocking.

Blocking is measured using a desensitization measurement procedure with progressively higher on-channel signal levels. Figure 8 shows the blocking of a hypothetical portable radio, as a function of frequency offset.

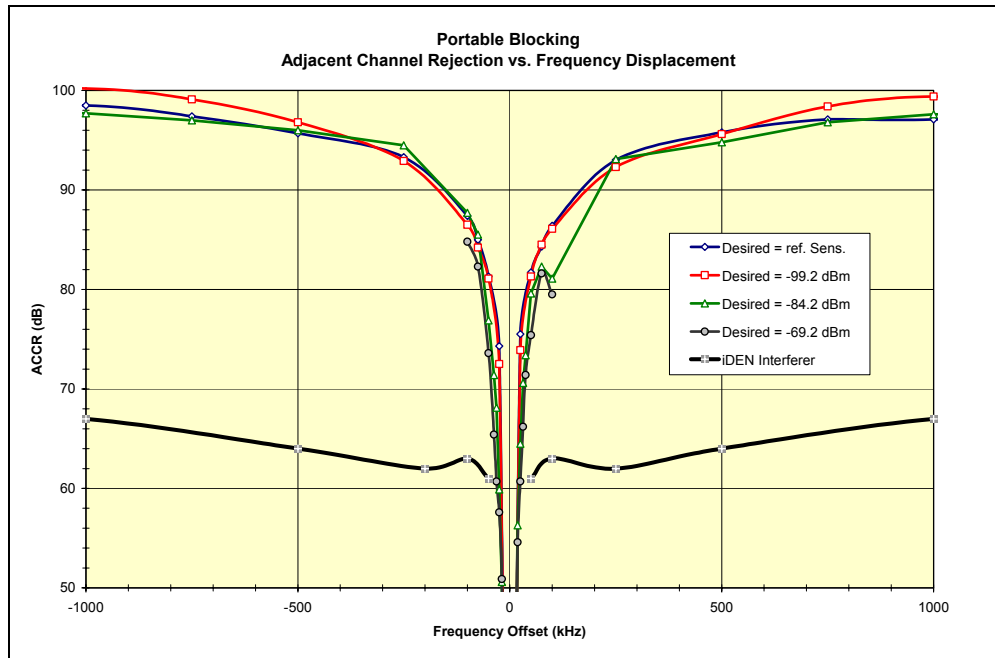

Figure 8 - Receiver Blocking

Figure 8 shows that with desired signal levels as high as approximately -70 dBm signal levels, no blocking phenomena occurs. There is a small degradation of the desensitization performance at offsets ≥ 100 kHz for desired signal levels of ≥ -85 dBm.

Figure 8 also demonstrates the desensitization performance at sensitivity level due to an iDEN base radio used as the interfering signal. The desensitization limit imposed by the iDEN OOB is nearly 20 dB worse than that of the hypothetical radio itself at any desired signal level. From this it can be concluded that **receiver blocking due to high signal levels is not a significant source of interference, at least where the limiting interference source is from the noise contribution of a base radio generating strong OOB emissions.**

7.0 RECEIVER INTERMODULATION

Receiver front-end (RF Amplifier) non-linearity can create intermodulation products on the desired frequency by mixing two or more high level signals, typically ≥ -50 dBm. Figure 9 shows sensitivity level intermodulation rejection (IMR) for typical receivers, relative to the receiver's reference sensitivity signal level. For practical purposes, IMR is not a function of frequency offset, as the preselector doesn't provide additional rejection of potential Intermodulation combinations across the receiver's desired band pass. As a result, the IM performance is essentially flat in the desired band. The preselector does provide additional protection from signals outside the pass band. However, preselectors in portables have to be small and broad to minimize space requirements and low insertion loss respectively. For each additional dB of insertion loss, the IMR products are reduced by the order of the IM product, e.g. 3 dB for 3rd order IM. This insertion loss results in better IM performance, but at a loss of sensitivity and therefore coverage.

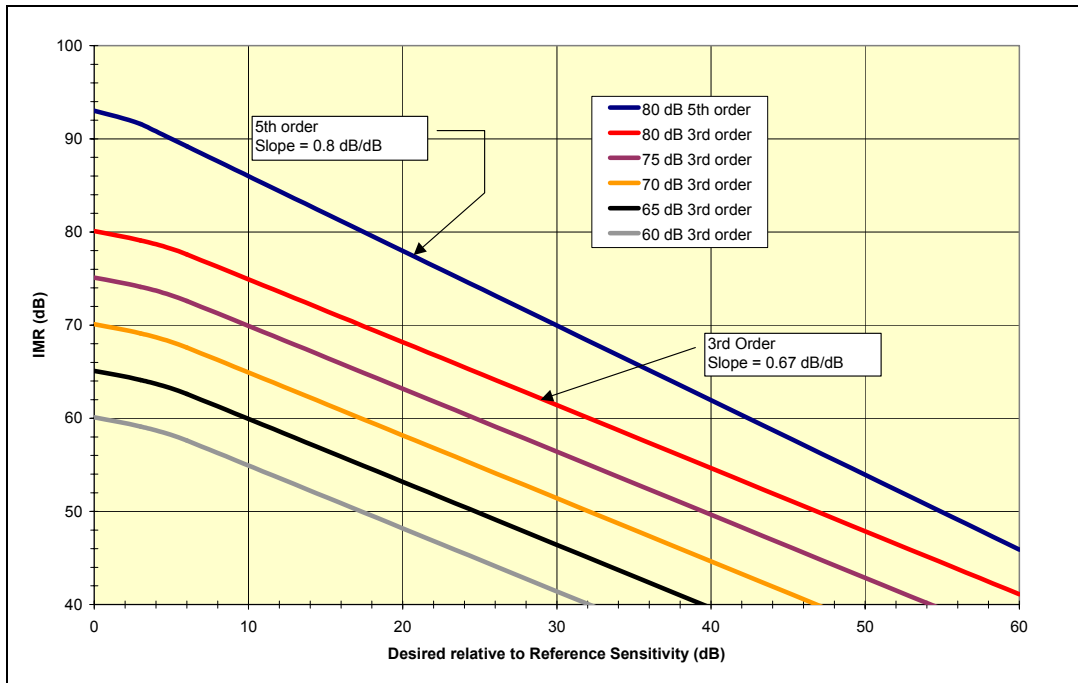

Figure 9 - Receiver IM Above Reference Sensitivity

While IMR is not a function of frequency offset, it is a function of the level of the desired signal. This is because the signal strength of intermodulation products grows at a rate proportional to the order of the intermodulation product. For example, third order intermodulation products grow 3 dB for every 1 dB increase in signal strengths of the carriers that produce them. Because of this, the IMR is reduced by 2/3 dB for each 1 dB increase in the desired signal level. This effect is shown in Figure 9. An example is provided later in this section. For example, if the desired signal is increased by one dB, the interfering signals must be increased by only 1/3 of a dB to produce the same equivalent noise. Thus the difference is 2/3 dB per dB.

Figure 9 shows that all the products normally follow the 2:3 slope expected for IMR with increasing strength of the desired signal. It is important to note at this point that IMR, as measured using TIA methods, is concerned only with a two-generator, third order IM process. Higher order (5th, 7th, 9th, etc., order) processes also exist but are usually of a lesser concern because they require much larger interference signal levels than does the third order process. Three generator IM processes produce a slightly lower measured IMR due to the increased power from the additional signal.

In situations where there is a high concentration of high-powered transmitters with high duty cycles, the higher order IM products can become significant for receivers in close proximity to the site. Figure 9 also shows a 5th order response for an 80 dB (3rd order IMR) receiver. The 5th order IM specification is typically 12 to 15 dB higher than the 3rd order IM specification. Although the 5th order IMR is much higher than the 3rd order IMR, its slope is greater so that 5th order IM can become a problem in situations where there are a large number of carriers. Although not shown, the 1-dB compression point is also very important. The 1-dB compression point exists roughly 10 dB below the IIP³ and represents where the theoretical slope departs by 1 dB from the linear performance. Signal levels greatly in excess of the 1-dB compression point can cause the amplifier to saturate and eventually burn out.

The use of receiver multi-couplers and tower top amplifiers can have a dramatic negative effect on a base station's receiver IMR performance. This is due to the fact that the IIP³ is constant. The reserve gain of the amplifiers in the configuration raise both the desired signal and the potential IM signals, resulting in a

reduction in the system IMR, due to the leverage the IM sources have over the desired signal. Figure 10 graphically demonstrates this.

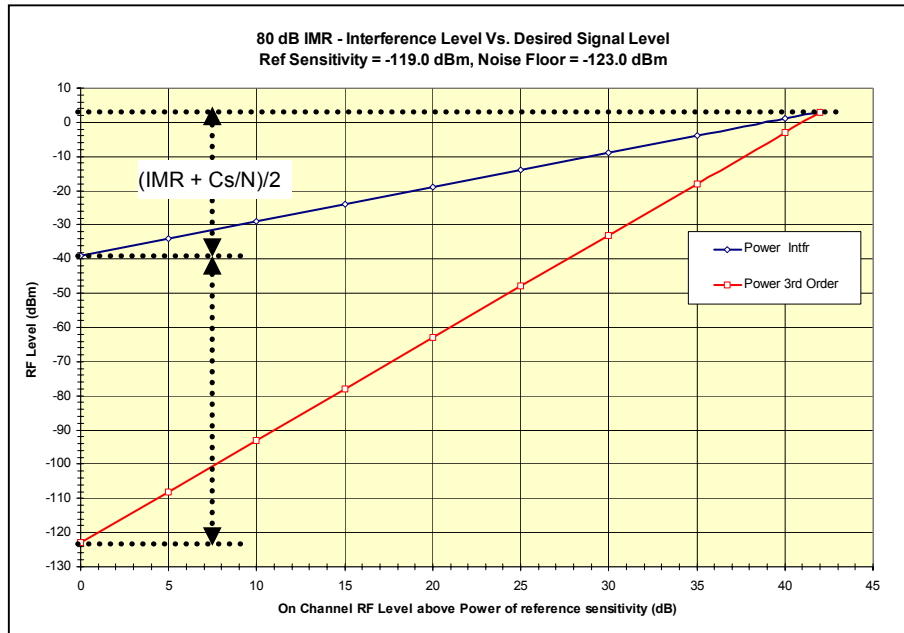

Figure 10 - IMR Performance

In Figure 10, the reference sensitivity for 12 dB SINAD is -119 dBm, Cs/N is 4 dB and the IMR is 80 dB. The noise floor calculates to be -123 dBm. The IIP^3 is $1.5 \times (84)$ or 126 dB above the noise floor (+3 dBm). The individual power level from two equal interferers that produce an IM response on frequency is 42 dB below the IIP^3 , -39 dBm.

To review, using the TIA IMR test methodology, consider the previous example. The -119 dBm produces a 4 dB Cs/N that creates the 12 dB SINAD reference sensitivity. The signal is boosted by 3 dB (-116 dBm) and the equal signal level interferers are increased until 12 dB SINAD is again reached. This indicates that now a 4 dB Cs/(I+N) has been reached but the desired is now -116 dBm. Thus the composite noise floor is -120 dBm, consisting of -123 dBm from the receiver noise floor and -123 dBm, the equivalent noise from the intermodulating signals. The difference between the original signal (-119 dBm) and the level of the IMR signals (-39 dBm) is the IMR performance of the receiver (80 dB). Note that at higher signal levels, the receiver's own noise floor becomes insignificant and the ratio is merely the difference between the desired and the IMR signals required producing 12 dB SINAD. This explains why the slope in Figure 9 tends to flatten out in the region near reference sensitivity, where the receiver noise floor is significant.

If the desired signal for the example 80 dB IMR receiver is 20 dB above reference sensitivity, -99 dBm, the difference between the IMR sources and IIP^3 is 102 dB. The level of 2 equal signal IM generating sources $102/3 = 34$ dB below the IIP^3 . (+3 dBm - 34 dB = -31 dBm). Thus for this example the IMR is now -31 dBm - (-99 dBm) = 68 dB, not 80 dB! In this case the two IMR signals produce an equivalent noise of -102 dBm. The receiver's own noise floor of -123 dBm is insignificant. It is important to note is that even at -99 dBm, the resulting performance is only equivalent to the static reference sensitivity performance. This phenomenon supports the recommendation for deploying higher IMR receivers when the victim receiver can be close to the source that can produce IMR.

8.0 RECEIVER SPURIOUS RESPONSES

Receivers can have spurious responses to strong single signals, typically in excess of -50 dBm, which are on frequencies other than the desired receive frequency. Examples include the 1st IF image response, the 2nd IF image response, the half IF response and any harmonics of the local oscillator mixing with any harmonics of the undesired signal.

Using the typical receiver in Figure 11, if the IF frequency is 11.7 MHz, and the desired signal is 460.0000 MHz, the Local Oscillator must be either 11.7 MHz above or below to cause an 11.7 MHz signal to be generated in the mixer. If the LO is below by 11.7 MHz (448.3 MHz) or above (471.7 MHz) proper operation can occur. With wider preselectors, the image frequency can easily fall within the passband of the preselector. To reduce the possibility of this occurring, the IF frequency should be greater than the preselector's bandwidth. The dashed line in Figure 11 shows how the preselector bandwidth must be less than the IF frequency. Modern wide bandwidth receivers use very high IF frequencies to be able to achieve the desired operational bandwidth without these spurious responses.

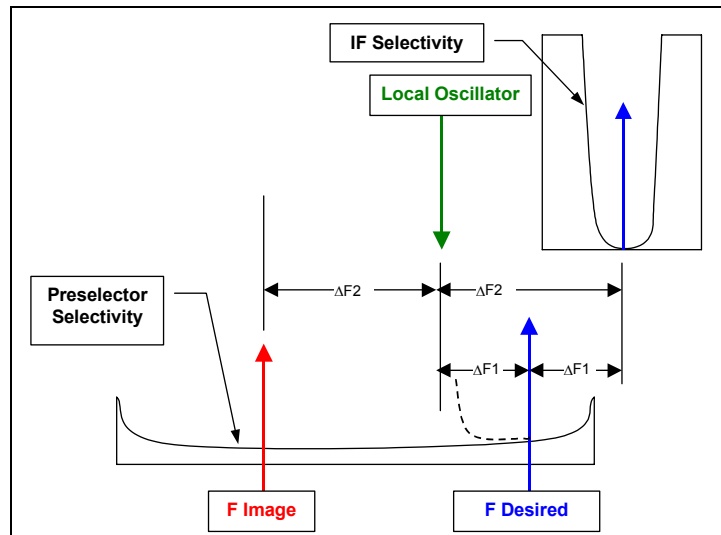

Figure 11 - Typical Receiver With A Wide Preselector Passband

Table 2 - Spurious Response Formulas

Spurious Response	Formula
IF Image	$f = f_{LO} \pm 2f_{IF}$
Half IF Image	$f = f_{LO} \pm \frac{1}{2}f_{IF}$

The spurious responses of a receiver can cause significant degradation to the desensitization properties of the receiver, on the order of 20 dB in some cases. In most cases, when the interfering signal is due to a base radio with high OOB Emission, the desensitization performance is dominated by that noise floor rather than the spurious responses.

9.0 DETERMINING THE SOURCE OF INTERFERENCE

9.1 Test Equipment Required

1. Spectrum analyzer.
2. Low noise RF amplifier.
3. Step attenuator (pad).
4. Cavity, bandpass filter that has a bandwidth (± 3 dB) of at most 300 kHz (± 150 kHz), an insertion loss of at most 2 dB and that can be tuned to the desired channel.
5. Antenna for the frequency band in question.
6. Subscriber unit that can be connected to a coaxial cable.
7. Motorola Radio Service Software (RSS), or equivalent, loaded on a suitable PC laptop computer to read receive signal strength; if applicable. This capability may not exist for all radios in which case one must listen to the radio's speaker and judge the quieting level.

9.2 Evaluation Procedure for Interference to Subscriber Units

The interference evaluation process begins by visiting the affected location, setting up the subscriber unit and connecting the test equipment as shown in Figure 12 below:

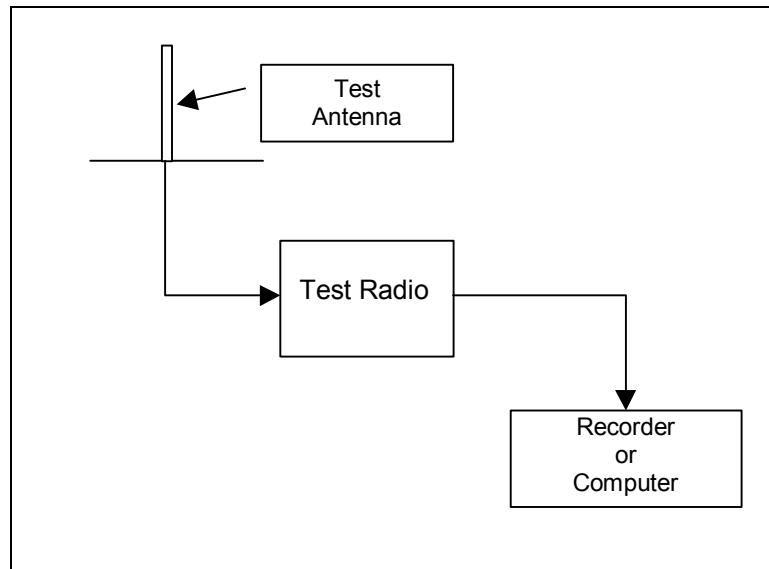

Figure 12 - Initial Evaluation

Tune analog units to the appropriate RF channel, and observe the recovered audio quality by recording about two minutes of the audio while slowly driving the test vehicle around in at least a 100-foot circle. The audio should have noticeable degradation compared to the normal reception expected in the general area. After the recording has been made, replay it several times to become familiar with the type of audio degradation that is occurring.

If the subscriber unit uses digital modulation, and the Radio Service Software (RSS) package includes a signal quality metric, it may be more appropriate to record the data from that output on a computer for analysis.

Next, connect the spectrum analyzer to the antenna as shown in Figure 13:

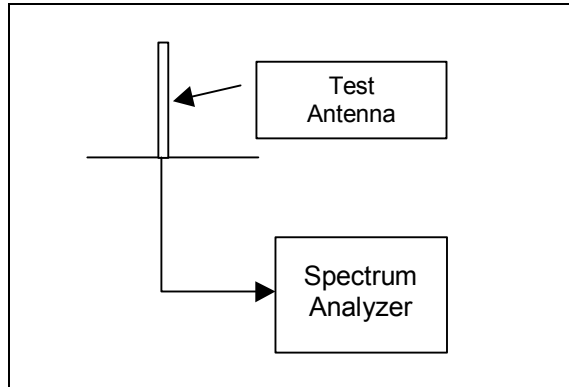

Figure 13 - Evaluation With Spectrum Analyzer

Record all signals in the frequency bands that are above (stronger than) -50 dBm. Pay particular attention to those above -40 dBm, as they are the most likely to cause problems, particularly if there are several of them within a few MHz of the desired frequency. A rough guideline is to suspect receiver front-end overload if the total instantaneous peak RF power being delivered to the receiver is in excess of -20 dBm.

In order to correctly measure the power of any RF signal with a spectrum analyzer, it is necessary to use a resolution bandwidth in excess of the maximum spectral distribution of RF energy expected. For analog FM signals, this is typically 10 kHz. For narrowband cellular type digital modulation formats, this may be up to 30 kHz, and as much as 1.25 MHz for CDMA transmissions. The reason for this is so that the entire signal will be measured at the same time. The best procedure is to adjust the analyzer frequency span range until the desired signal is centered in the display screen and occupies about 20 percent of the width of the display. Then start at a 1 kHz resolution bandwidth and increase it until there is no further increase in the maximum amplitude shown on the display.

Be aware that multiple RF signals of any modulation format will occasionally add in phase, so that four signals each at a level of -25 dBm will have a total peak instantaneous power that is another 12 dB higher, or -13 dBm.

If there are no strong signals, then the cause is either man-made noise, or co-channel interference from another user on the desired frequency. The difference can be resolved by connecting the equipment as shown in Figure 14:

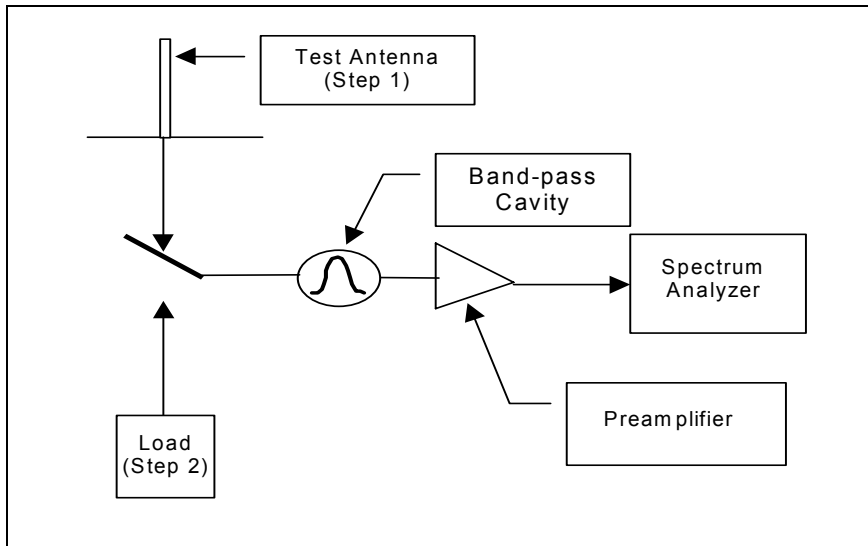

Figure 14 - RF Noise Measurement Setup

Using a resolution bandwidth no wider than 3 kHz and a frequency span no greater than 3 times the desired RF channel bandwidth, measure the noise present on the channel, then connect a 50 ohm load in place of the antenna. The noise level should decrease less than 1 dB if there is no noise or interference present. If there is a noticeable reduction, note the amount, then reconnect the antenna, and note the spectral content of the noise. If it is not restricted to the desired channel (Figure 15a), then it is most likely either from broadband digital services like CDMA systems or from non-RF sources such as power lines, neon signs, ignitions, and the like. If the noise is shaped to fit the channel (Figure 15-b), or a single frequency carrier appears in the channel, then co-channel interference is the cause.

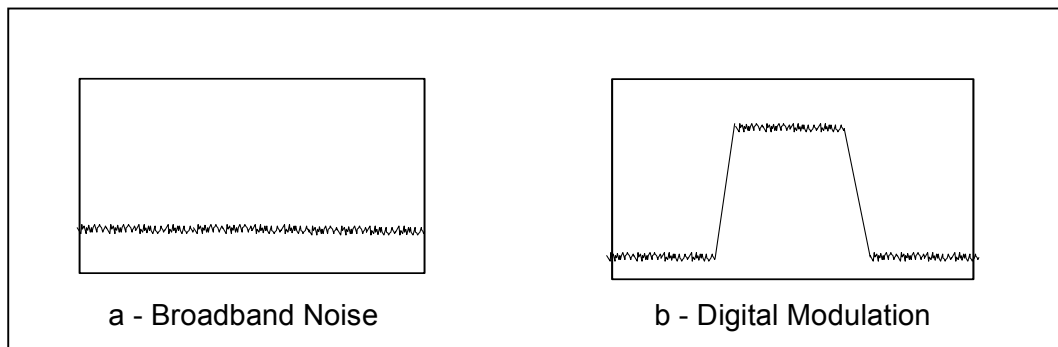

Figure 15 - Noise Appearance

If there is only one strong signal present, and it is the desired one, then the cause is simple receiver overload. The symptom is a very high desired signal strength, typically in excess of -30 dBm, with some degree of audio distortion. This is rare, but if it occurs, the only solution is to move the subscriber unit farther away from the transmitter site, place an attenuator in the receiver's antenna line or reduce the transmit effective radiated power.

If one or more strong signals are present record about two minutes of audio or data on the desired channel using the configuration shown in Figure 16. Listen carefully to the audio recording several times to get familiar with the recovered audio quality.

If the subscriber unit uses digital modulation, compute the average signal strength and signal quality for the entire recording of digital data. Next, add a 5 dB pad in the line between the antenna and the subscriber unit as shown in Figure 16 below:

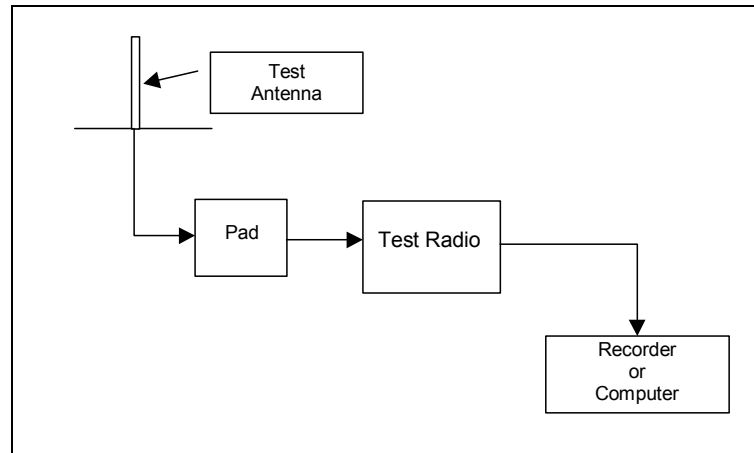

Figure 16 - Intermodulation Test

Record another two minutes of audio or data while driving the exact same route as in step 1 and note the differences from the non-attenuated readings. The received signal strength should have been reduced by 5 dB, but if the audio or signal quality **improved** noticeably, then the root cause is a high order intermodulation product being generated in the receiver.

Subscriber units using digital modulation will clearly show the reduction in received signal strength while simultaneously indicating the improved signal quality. This type of response usually results from two or more strong signals at the receiver input.

If the received signal strength decreases by 4 dB or less when the 5-dB pad is switched in, the cause is receiver front-end overload, resulting from one or more extremely strong signals anywhere in the frequency band. The reason for this is that one of the amplifier stages in the receiver is being driven into saturation by the extremely strong input signals. This effectively reduces the gain of that stage for all signals passing through it. When the strong signals are attenuated by 5 dB, the saturation is reduced, and the effective gain of the amplifier stage increases, so the measured signal strength decreases less than 5 dB. If the audio quality or signal quality remains unchanged when the 5-dB pad is switched in, then the problem is either due to receiver local oscillator noise, or received RF noise from nearby transmitters.

If there are no strong signals closer than 500 kHz away from the desired channel, the cavity filter can resolve whether the receiver is at fault, or the interference is being radiated on frequency from the nearby transmitters. First, connect the external antenna to the analog subscriber unit as shown in Figure 17. Record about two minutes of audio or data on the desired channel. Listen carefully to the audio recording several times to get familiar with the recovered audio quality.

If the subscriber unit uses digital modulation, compute the average signal strength and signal quality for the entire recording of digital data.

Next, connect the antenna through the cavity filter as shown in Figure 17 below:

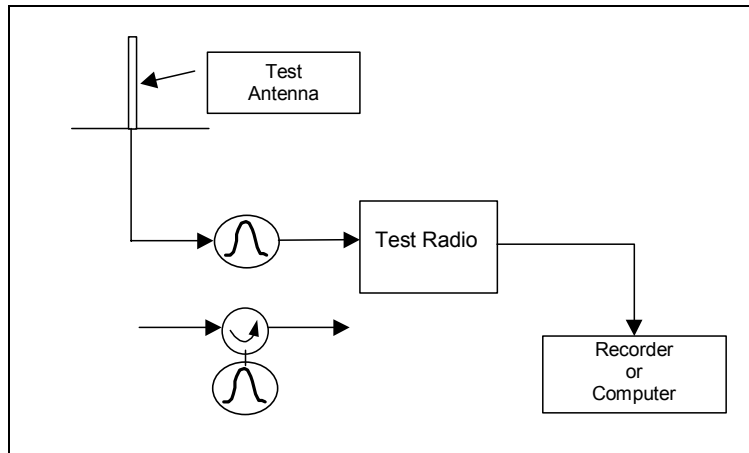

Figure 17 - Sideband Noise Determination

Record another two minutes of audio or data on the desired channel. Again listen carefully to the audio recording several times to become familiar with the recovered audio quality. Average the data recorded from digital subscriber units. If the audio quality or average signal quality has improved, the problem is a result of receiver performance limitations.

If it remains about the same, the problem is a result of unwanted RF power being radiated on the desired channel.

It is a special case if any strong signals are less than 300 kHz away from the desired channel. If there are, they are under suspicion right away, especially if they are iDEN signals. A high Q notch filter is needed to perform the above procedure instead of a cavity bandpass filter. This can be achieved by using a bandpass cavity and circulator.

If the above procedures have determined that the problem lies with nearby transmitters, the usual procedures for identifying the exact source(s) apply: If the transmitters are on continuously, shutting them down one at a time can isolate the offender. As this is unpopular with the system operators, a less intrusive method that can be applied if the transmitters are not continuously keyed is to observe the timing of the interference compared to the activity of the nearby transmitters as observed on the spectrum analyzer display.

10.0 INTERFERENCE VERSUS NOISE LIMITED SYSTEMS

Table 3 provides a condensed comparison between Interference Limited and Noise Limited systems.

Table 3 - Differences between Noise and Interference Limited Systems

Differences between Noise and Interference Limited Systems		
Characteristic	Noise Limited Systems	Interference Limited Systems
Frequency Plan	Static Very little change once established	Dynamic Constant changes to increase capacity and resolve Intra-system interference issues. Dynamic Channel Allocation (DCA) rearranges channel assignments throughout the day.
Co-Channel Reuse	35 dB C/I established by frequency coordination with co-channel user and defined static service areas	Intra System Issue Under control of the system operator
Adjacent Channel Allocations	Frequency Coordination based on ACCPR and defined service areas	Intra System Issue Under control of the system operator
Number of Sites	Minimum number to control costs. Maximum coverage from each site	Maximum number of sites to create large system capacity. High power to provide in-building coverage
Site Information	Available from FCC license	Area Licensed. No specific site information
Frequency Information	Available from FCC license	Area Licensed. No specific frequency deployment information
Site Separation Distance	Large based on maximum coverage per site	Small Decreasing over time as additional sites are added to increase capacity
Transmitter Filtering	Very selective filters to allow transmitter combining. This reduces OOB	Band filtering only to maintain maximum flexibility for dynamic frequency plan. Exposes noise limited systems to OOB
Tower Heights	Tall to provide maximum coverage per site. This provides excellent site isolation	Short and getting shorter. This limits intra system interference and allows more reuse of the channels to create more capacity. This reduces the site isolation thereby increasing Interference to Noise limited systems
Receiver IM Requirements	Normally moderate, but when interspersed with Interference limited systems this becomes a critical requirement due to strong interfering signals and moderate desired signal levels (FCC limitations). Limited ability to increase beyond 75 dB for hand-held radios due to increased current drain, resulting in less transmit time or increased physical size.	Moderate as there is a strong desired signal always present to overcome any intermodulation products. Subscriber units have power control to minimize up-link intermodulation

11.0 800 MHz BAND EXAMPLE INTERFERENCE SCENARIOS

In most band plans (except Low Band and High Band) there are transition points where the base transmit block of frequencies are adjacent to the base receive block of frequencies. High band and Low band do not follow this due to their earlier development before mobile relay became the dominant type of system deployment. Across this transition there is the potential for base station T to base station R interference in one direction and mobile T to mobile R in the other direction. Within the blocks there is potential for the classic near/far interference scenarios. This can occur as base – mobile interference or mobile – base interference. Recently the frequency of occurrences in the 800 MHz band has become more common, as summarized in Figure 18.

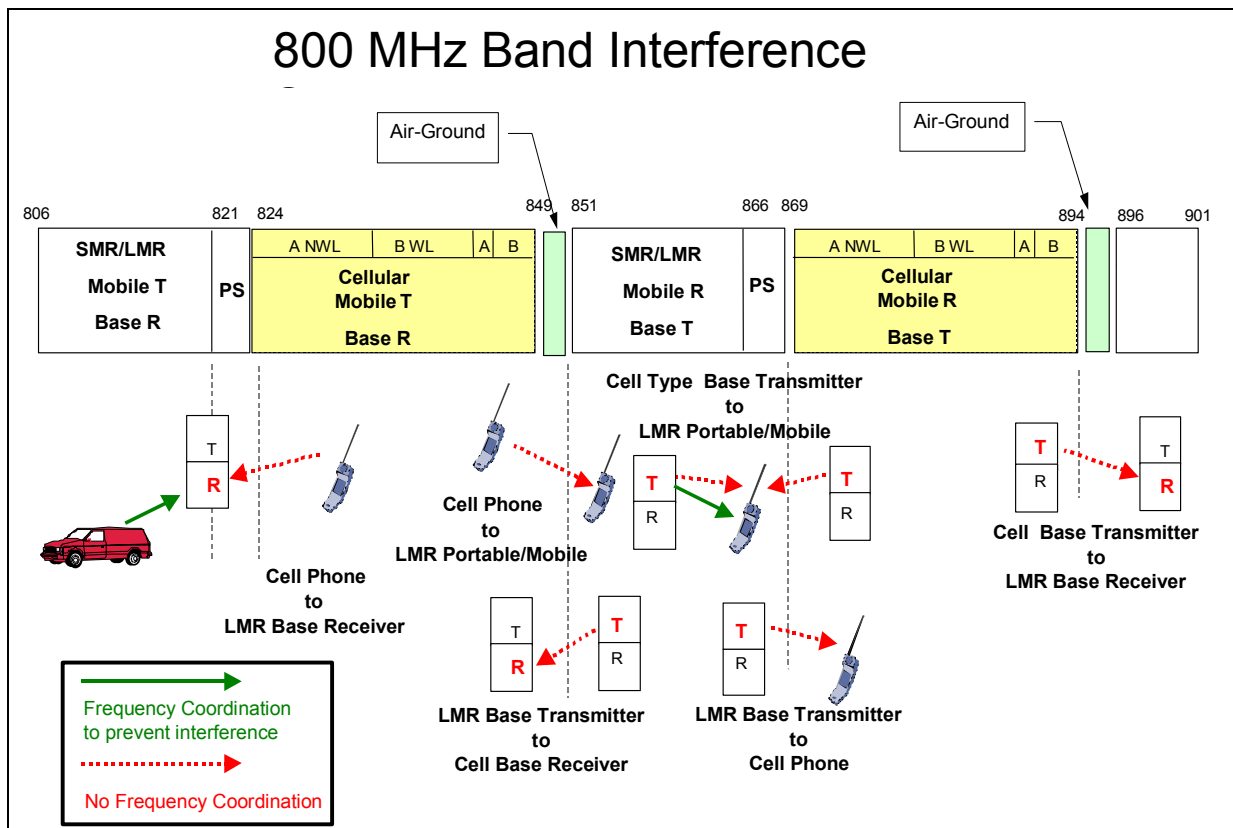

Figure 18 - 800 MHz Band, Interference Scenarios

The following examples (Transmitter to Receiver Cases) will be individually diagrammed, with a table like Table 4 to show the factors that can create interference, and methods to minimize or prevent that interference.

The logic of the example groupings is that a number describes the type of interference, e.g. Base to Subscriber, but there are different situations because of band breaks, how the systems are deployed and other variables that are involved in the specific configuration.

11.1 Scenarios

1. A) LMR⁴ Base to LMR Subscriber
 B) SMR Base to LMR Subscriber
 C) Cellular Carrier Base to Public Safety Subscriber
2. LMR Base to Cellular Phone
3. Cellular Base to 900 MHz Base
4. LMR Base to Cellular Base
5. Cellular Subscriber to LMR Subscriber
6. A) LMR Subscriber to LMR Base
 B) Cellular Subscriber to LMR Base

Table 4 - Generic Interference Scenarios

Source of Interference Transmitter Type					
	Cellular Analog	Cellular TDMA	Cellular CDMA	LMR/SMR Analog	LMR/SMR Digital
Transmit Interferor Characteristics					
Combining/ Filtering	High Q Cavity	Hybrid	Multi-CXR Amp	Band Only	
Multiple Transmitters	Yes	No			
Duty Cycle	Intermittent	Continuous			
Power Control	Yes	No			
Isolation From Source	High	Low			
Antenna Type	Omni	Directional			
Victim of Interference Receiver Type					
	Cellular Analog	Cellular TDMA	Cellular CDMA	LMR/SMR Analog	LMR/SMR Digital
Receive Characteristics					
IMR > 75 dB	Yes	No			
Filtering Possible	Yes	No			
Frequency Coordination					
Frequency Coordination	Yes	No			
Type Of Coordination	Co-Channel	Adjacent Channel	Adjacent Band	Guard Band	Reuse Plan
Frequencies Are Closed Spaced	Yes	No			
Sources Are Physically Close (distance)	Yes	No			

For each example, only the appropriate table sections for that interference scenario will remain legible. Those not appropriate will be darkened. For understanding the table, the rows contain the important information. The columns are not related to each other, other than representing the specific variables being considered in each row by remaining unshaded.

There are two considerations as far as the band is concerned. The cellular band is specifically identified and treated differently than the LMR/SMR band, which includes the exclusive public safety (NPSPAC) portion of the band. For cellular, there are currently three different types of modulations deployed. They

⁴ LMR is Land Mobile Radio

include analog, which is referred to as AMPS or NAMPS. AMPS is the original 30 kHz channel bandwidth assignments while NAMPS is a Motorola narrowband version that limits the channel bandwidth to 10 kHz. The Time Division Multiple Access (TDMA) is the 3:1 - 30 kHz channel bandwidth version. Code Division Multiple Access (CDMA) is the 1.23 MegaChip version currently being deployed across markets in the United States. Typically combinations of these modulations can be deployed at any given site. Each cellular carrier selects what they wish to deploy.

In the LMR/SMR band there is currently only analog and some digital, with the digital being principally deployed in the Public Safety band as Project 25 (P-25) systems. However, Nextel has deployed iDEN systems throughout the LMR/SMR band.

Different systems use different transmitter combining techniques. Because LMR systems are narrow band utilizing static frequency plans, they typically use Hi-Q cavity combiners, while SMR's frequently uses broadband hybrid combiners to allow frequent frequency changes without requiring site visits.

The Multiple transmitter indication is there to identify where intermodulation products are the easiest to generate.

The duty cycle indicates whether the transmitter(s) are continuous as cellular type deployments require or intermittent as typical of LMR systems use. Note that when a trunking system is involved, the control channel may be continuous while the voice channels are intermittent.

Power Control applies primarily to subscriber units. When power control is available, the subscriber unit limits its output power based on information from the base site. This requires a full duplex path so that the feedback information is constantly updated. For the base station to use power control requires that only a single path be used per base station or that "smart antennas" allow ERP controlled full duplex paths to individual units. This is possible for "interconnect" type calls but isn't possible for dispatch as most of the units are only monitoring the "channel".

The isolation indicated as either High or Low refers to the typical losses involved. There are two different methods used to calculate site isolation. The simplest is to use the port-to-port isolation between the input to one antenna to the output of the other antenna (see the Site Isolation Section 12). The other is to use a propagation model and adjust for the specific antenna gains and propagation losses. The reason for differentiating them is that for the typical scenario being discussed, there is typically between 50 & 75 dB of port-to-port isolation to subscriber units operating in relatively close proximity of the site. Note that the port-to-port isolation includes the antenna gains. This makes estimating the effect of OOB emissions much easier. If the OOB emission is -50 dBm, then 70 dB of isolation would produce a -120 dBm interferer at the output of the victim's antenna. However when base-to-base interference is being analyzed, the paths are typically point-to-point and the antenna gains and minimal free space losses can dramatically reduce the amount of attenuation experienced by the OOB emission. The recent increased usage of "stealth" sites, with very short towers, has caused a reduction in the amount of site isolation available.

Antenna types are important due to potential directionality.

The victim receiver flag for IM performance is based on the recommendation that 75 dB IMR be considered as a minimal specification. Portable antennas allow some reduction in this requirement as the loss of efficiency acts like an attenuator to potential IM.

The filtering refers to what can be done at the receiver. Components that are already on frequency cannot be filtered at the victim receiver; they must be filtered at the source. However IM producing components can be filtered before reaching the active stages of a receiver where the IM occurs.

Lastly, the issue of frequency coordination is highlighted as a yes or no. This is an extremely important but not well understood aspect of interference potential. Frequency coordination normally requires that

someone (a frequency coordinator) evaluates the use of different candidate frequencies in various defined service areas and then recommends the candidate frequency that doesn't cause interference, or is the best choice from a limited selection. This normally involves evaluating only co-channel usage, but is being expanded to include adjacent channel interference potential. The frequencies are licensed based on the specific site and the ERP being used (referred to as site licensed). SMR's and cellular carriers have special circumstances where they can use any of their inventory of frequencies anywhere in their defined service area, subject to some co-channel reuse limitations where others may be licensed on the same frequencies. As a result, there is no available database of which and where their frequencies are deployed (referred to as area licensed). This allows them the capability of rapidly changing their frequency plan to allow new sites to be deployed thereby adding capacity or dynamically changing the plan to eliminate intra-system interference. A frequency plan covers a wide area and may be coordinated nationwide. A single change can ripple across the entire system, making exceptions more difficult.

The types of coordination are also listed. In some cases a guard band is provided to take the place of frequency coordination. It is implied that when a different band is used, the requirement for frequency coordination is eliminated. Unfortunately, with the wide band and high OOB of some of the more complex modulations, this assumption is not longer true. The wide band OOB is radiated into the adjacent or guard band and must be dealt with to minimize interference potential. Cellular type systems utilize frequency reuse plans. This allows a structured starting point for doing internal frequency coordination. The key point is that they are primarily concerned with their own intra-system interference. This type of frequency planning (interference limited) is based on the fact that when the interference gets strong enough, the system will be able to provide an alternative resource that isn't being interfered with.

The other two references under frequency coordination refer to whether or not the frequencies are close (a small frequency offset) or whether units can get into close physical proximity, thereby causing the interference.

11.2 Case 1a, LMR Base to LMR Subscriber

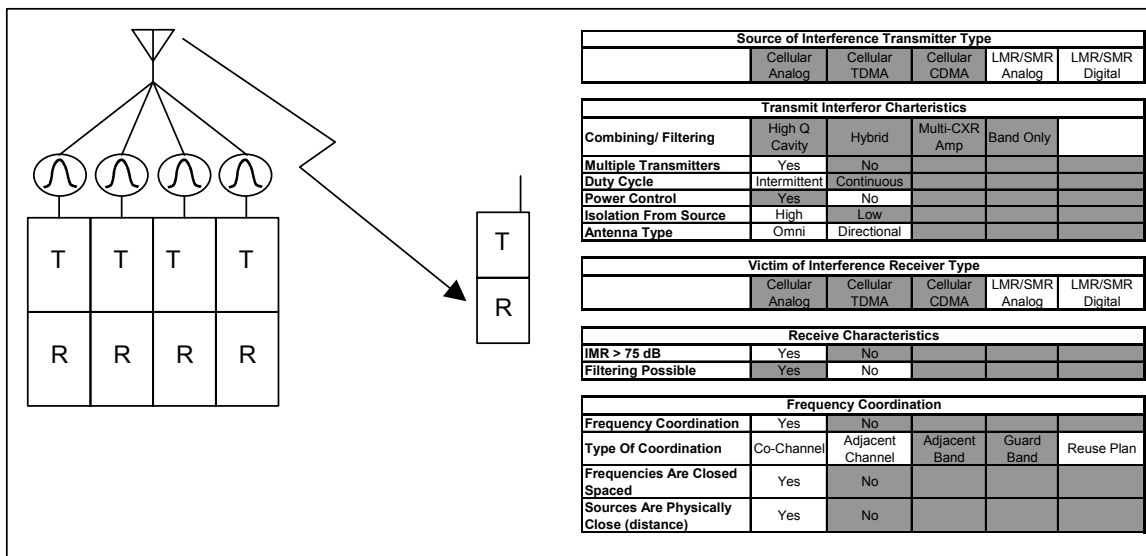

Figure 19 - Case 1a, LMR Base to LMR Subscriber

This is a very common scenario where a subscriber unit can be very close to a site that generates interference. In this case, the transmitters have Hi-Q cavities to limit the OOB. The frequency coordination should have eliminated co-channel and adjacent channel interference. If the receiver has an

IMR specification of ≥ 75 dB this scenario would normally be interference free. However, if the undesired IM sources are considerably stronger than the desired signal, the IM "Noise" can prevent the required $C/(I+N)$ from being realized.

However there are some situations where intra site interference can occur for users of that site when they are in close proximity. Figure 19 doesn't show the base receive site configuration. If there is low isolation between the base Transmit and base Receive combiners, then when two subscribers in close proximity to the site transmit a temporary lockup scenario can occur.

Consider the simple two-transmitter/receiver configuration shown in Figure 20. When the subscribers are close to the site, they produce strong signals that can enter the transmitter antenna system. Here the difference in frequencies cross modulate at a loose connector producing the necessary products which are re-radiated to keep the receivers satisfied that they are seeing the correct CTCSS tone or Trunking Connect Tone. When one subscriber de-keys, the cross modulation generates an on frequency interferer that continues to repeat the weak interferer with the other users audio. It is not until the second subscriber de-keys that the lockup will be released.

This can only be resolved by isolating the Transmit and Receive systems, e.g. by vertical antenna separation, and making sure that there are no extraneous locations for this IM to occur. This can also occur externally on the site, such as on rusted tower bolts, etc. For trunking, the use of transmission trunking forces the repeater to also immediately dekey thereby preventing this phenomenon.

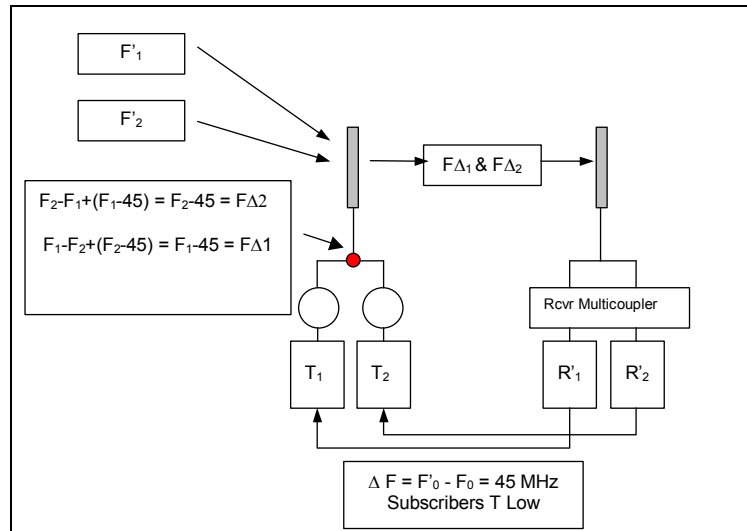

Figure 20 - Intermodulation Example

11.3 Case 1b, iDEN Site to LMR Subscribers

In Case 1b, the interferer is an iDEN site deploying multiple transmitters as shown in Figure 23. This is a high potential interference scenario due to the fact that the transmitters are hybrid combined and therefore only have limited in-band filtering. The carriers are continuously keyed and subscribers can get in close proximity both in frequency and space with no frequency coordination.

The worst case involves combinations of frequencies that cause on-frequency receiver IM products. This is especially detrimental to receivers with low IMR specifications. If there is sufficient desired signal strength, inserting an attenuator in front of the receiver will reduce both the desired and undesired signals but the IM product of the multiple undesired signals will be suppressed more than the desired signal is attenuated. A building acts much as an attenuator. Building attenuation will reduce the desired by a given amount amount, but it also reduce the IM^3 product by three times the building attenuation, allowing the desired to achieve a usable $C/(I+N)$.

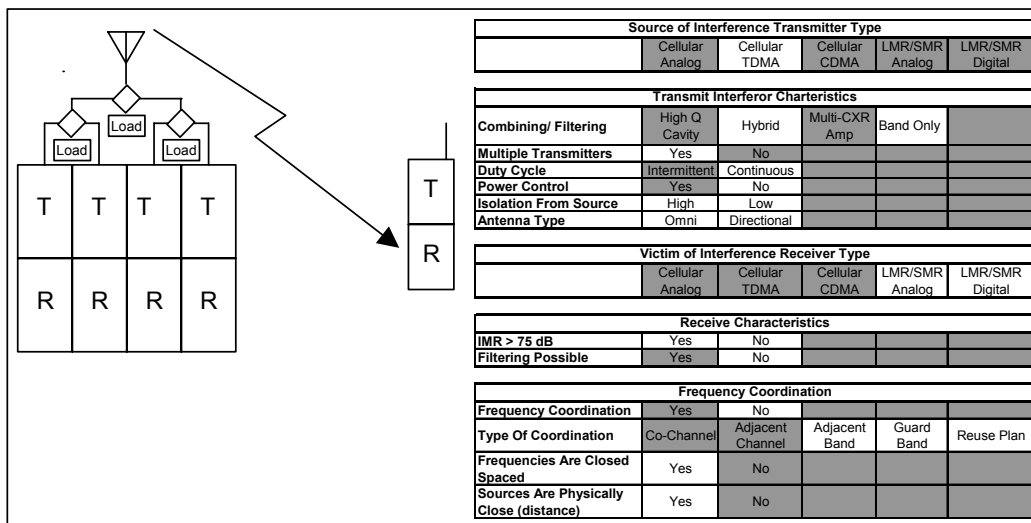

Figure 21 - Case 1b, SMR iDEN Site to LMR Subscriber

The coordination and reassignment of frequencies deployed at a particular site can eliminate the IMR, allowing the situation to be resolved. Long term resolution requires constant monitoring of frequency plan changes, proactively preventing IM creating combinations from being deployed.

11.4 Case 1c, Cellular Carrier to Public Safety Subscriber

Case 1c is similar to the other Case 1 scenarios except that the interference emanates from transmitters in an adjacent band (Figure 22). The symptoms are similar to the other Case 1 scenarios as this produces coverage holes around the offending site. Due to pressures for minimizing antenna sites, many of the cellular carriers are co-locating. This greatly increases the potential for IMR due to the extremely high number of frequencies involved. The interference potential is increasing as cellular carriers abandon analog for the digital transmitters with higher OOB and eliminates Hi-Q cavities, deploying multi-carrier transmitters with only band filtering.

This scenario is especially destructive with older portables with 65 dB IMR specifications and preselectors that are designed for International in addition to Domestic distribution. That is because the International band for LMR extends 1 MHz into the Domestic cellular band. This situation is further aggravated if the portables utilize vehicular adapter consoles as this eliminates the portable antenna inefficiency and may even have mobile gain antennas.

Under these circumstances, 5th order IM becomes commonplace. It is not unreasonable for a 20 channel trunked system that has units that operate within ¼ mile of a combined carrier site to have over 1000 IM products distributed randomly over the various frequencies in the 866 - 869 MHz band. For this case, the highest receiver IM performance is mandatory!

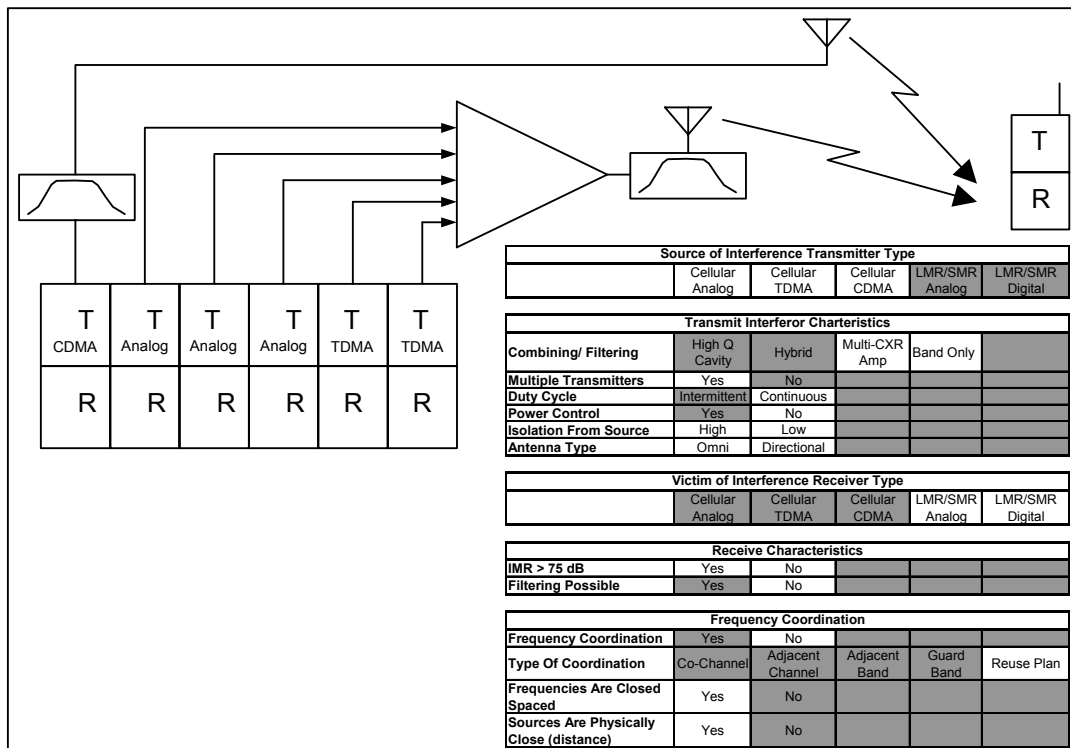

Figure 22 - Case 1c, Cellular Carrier Base to Public Safety Subscriber

The Case 1 scenarios all have a similar pattern of interference, wherein the interference potential is maximized where the desired signal is weakest while the interferers are the strongest. This is the classic Near/Far problem (discussed earlier in this document). A typical system wide scenario might look something like Figure 25 with the LMR base in the center. In this case, both Base-to-Mobile and Subscriber-to-Subscriber interference is portrayed. Only consider the size of the red zones around interfering sites at this time. The green distribution will be discussed later (Case 5).

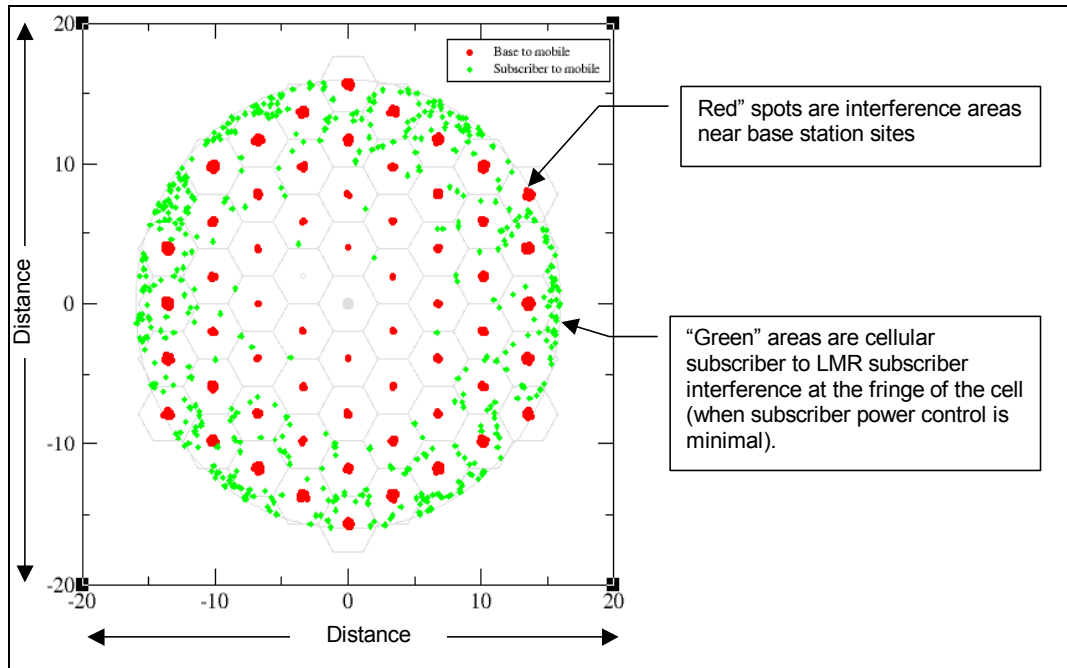

Figure 23 - Base-to-Mobile and Mobile-to-Mobile Interference Pattern

11.5 Case 2 LMR Base to Cellular Phone

Case 2 essentially is the opposite direction from Case 1. Now the LMR base station creates coverage holes around its sites for cellular subscribers (Figure 24). Although this case could cause limited interference, it is unlikely due to the fact that the stations are well filtered and the cellular subscribers have alternate sites to be handed over to in case of IMR type interference. Only Public Safety stations operate in the 866 -869 MHz band so their deployment density is quite low compared to the cellular deployment. The LMR transmitters have an internal band pass filter that provides protection above 869 MHz in addition to the HI-Q cavities. Together these greatly suppress any OOB emissions.

Tall towers, used in most LMR systems, provide high site isolation thereby resulting in low interfering levels even in close proximity to the sites.

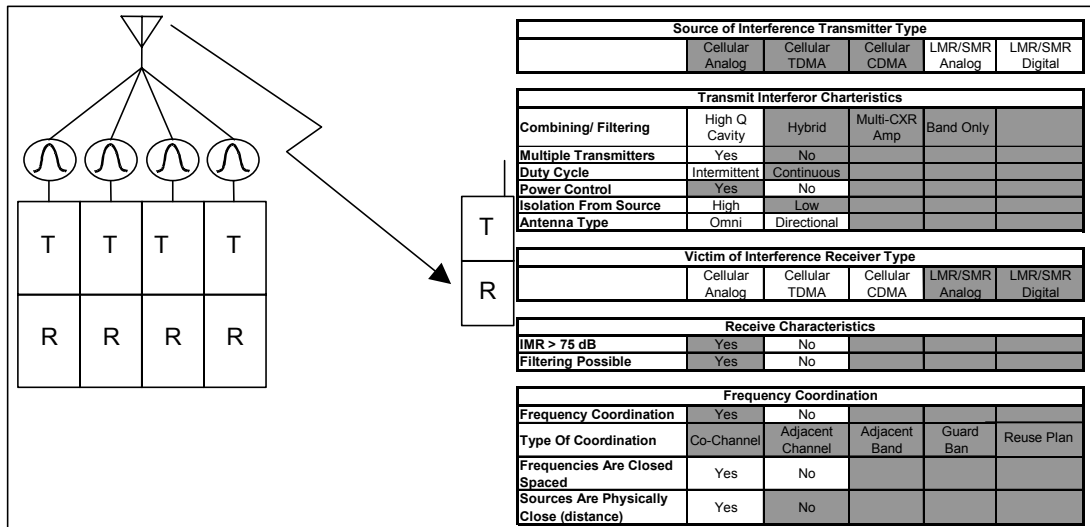

Figure 24 - Case 2, LMR Base Station to Cellular Phone

11.6 Case 3, Cellular Base to 900 MHz Base

Case 3 is the only 900 MHz scenario that will be evaluated (Figure 27). There are several documented cases of this type of interference, primarily caused by the Cellular B carrier. The high OOB of the various modulations and combinations of modulations along with only band filtering can produce a fairly high noise floor. In this case the noise is amplified by the gain of the transmit antenna and also the receive antenna. Because it is base-to-base interference, the paths often have only free space losses associated with them. At 900 MHz the free space loss between dipoles at 1 mile is 91 dB, but this is reduced by as much as 23 dB of antenna gains. Thus the isolation is less than 70 dB at one mile. However, sites can be closer than one mile and have even stronger interference potential. When CDMA and mixtures of analog or narrow band analog are present, the potential of IM increases. There is potential IM in the cellular antenna structure that would prevent any filtering at the 900 MHz LMR site from being effective. If CDMA is deployed, then there is also the potential of multiple sources of interference being received. When coupled with high performance TTA's (Tower Top Amplifiers) to compensate for low power 900 MHz products, the probability of interference is increased.

The configuration shown in Figure 25 is very important. Note that the CDMA is on a separate antenna from the narrow band modulations. If they were combined, the resulting IM of the CDMA with the narrow band carriers can create a very strong and wide noise source. Therefore the combining of wide band and narrow band signals in a linear amplifier is not recommended and should be avoided!

Interference from nearby Paging transmitters operating without cavity filtering is also a frequent source of reduced coverage for 900 MHz base receivers. Excess reserve gain in the TTAs on sites with high ambient noise levels will also reduce coverage.

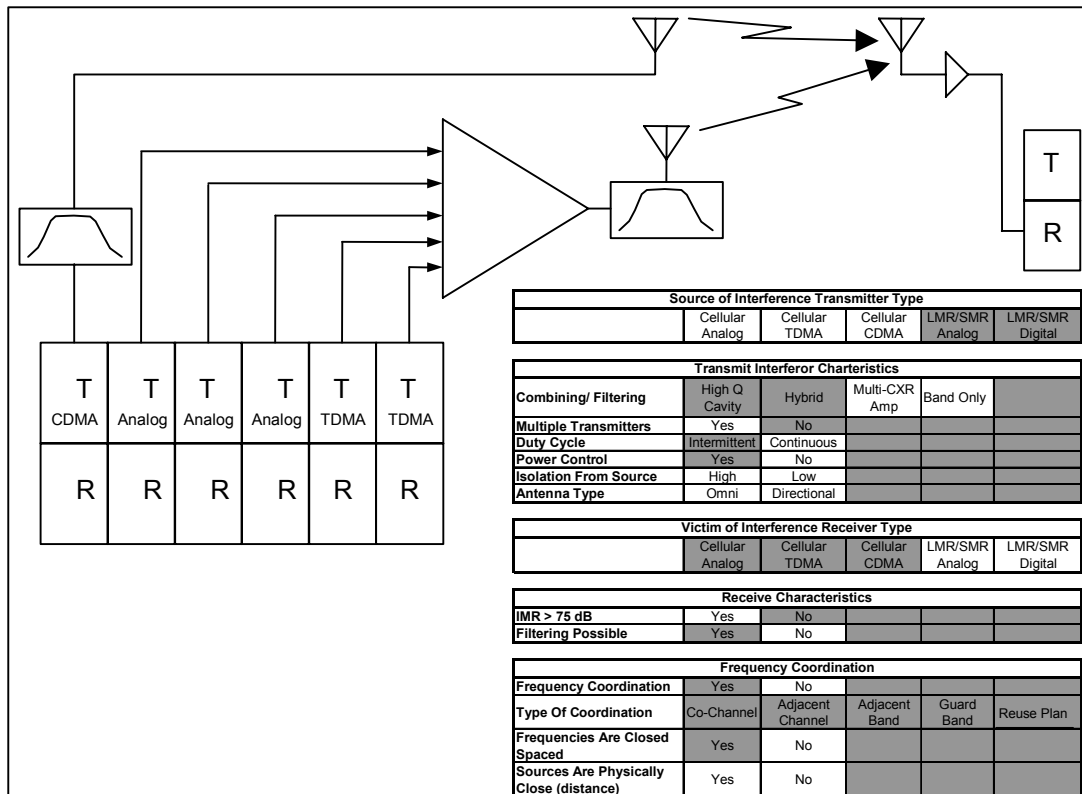

Figure 25 - Case 3, Cellular Transmitters to 900 MHz Base Receivers

11.7 Case 4, LMR Base to Cellular Base

Case 4 has LMR base stations causing potential interference to Cellular Base station receivers (Figure 26). There is little likelihood of this because there is a 2 MHz guard band between the LMR band and the cellular band. Motorola LMR base stations are heavily filtered and provide over 50 dB of suppression at the high end of the cellular base receive band, 849 MHz, as shown in Figure 27. The aeronautical band provides a 2 MHz guardband. This coupled with Hi-Q cavity filters should suppress OOB emissions adequately to prevent cellular base stations from being interfered with. Even if they were interfered with, the density of LMR base stations is quite low compared to cellular base stations. The cellular system's ability to hand over subscribers to other resources make this type of interference even less likely.

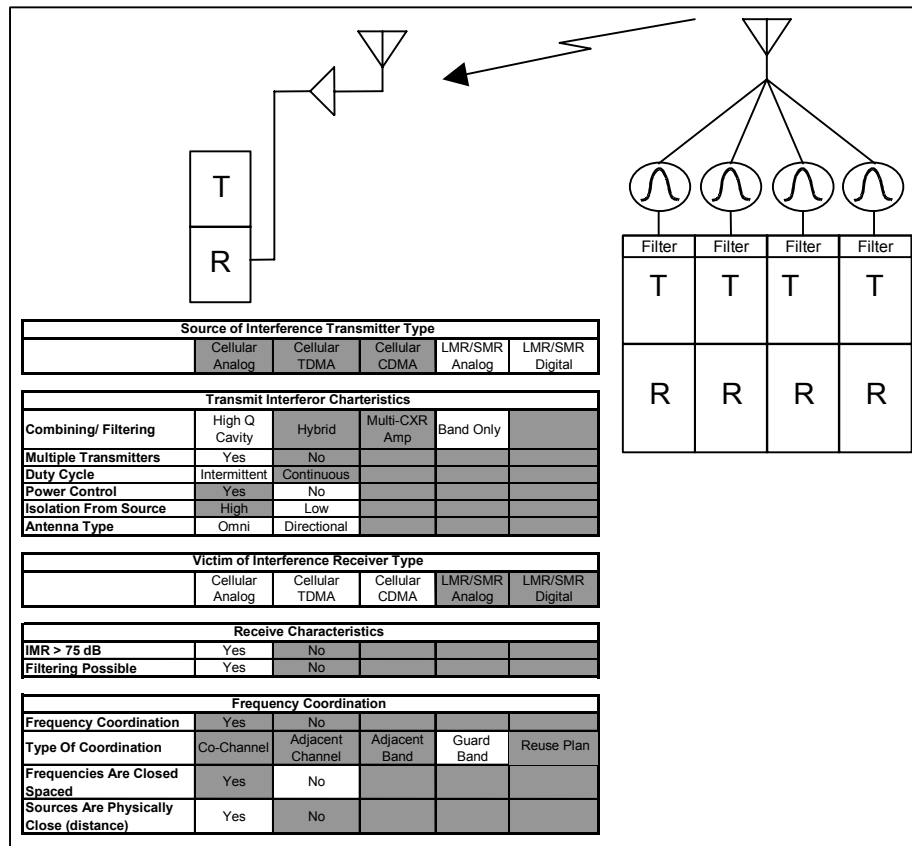

Figure 26 - Case 4, LMR Base to Cellular Base

Typical SMR Transmitter Filter

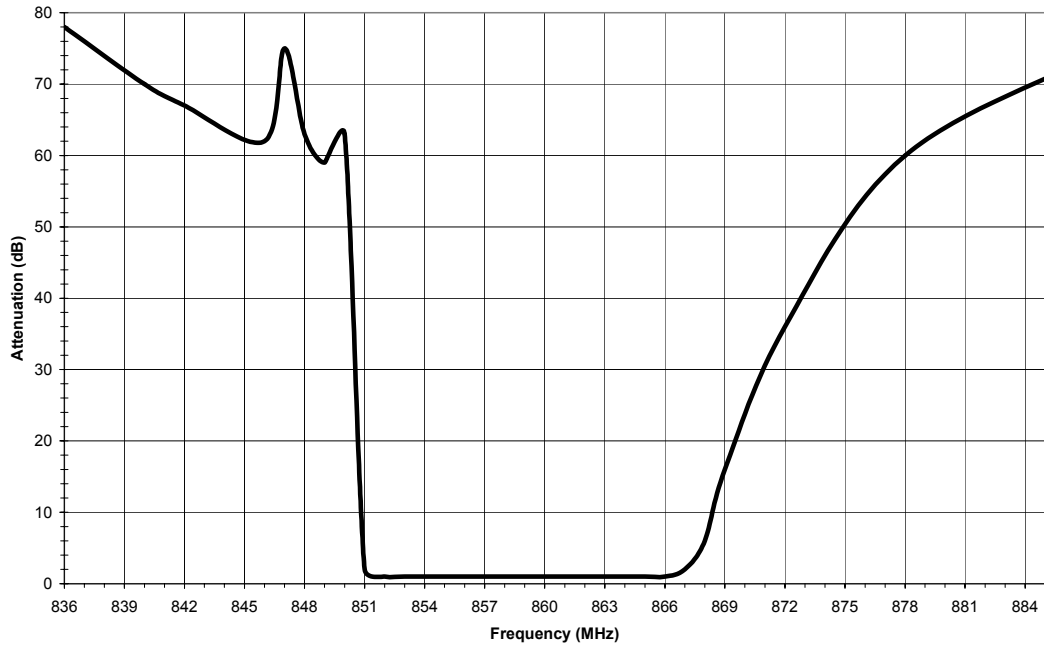

Figure 27 - Typical Motorola iDEN Base Station Internal Bandpass Filter

11.8 Case 5, Cellular Subscriber to LMR Subscriber

Case 5 is where Cellular Subscriber units can interfere with LMR subscriber units (Figure 28). There are several mechanisms that need to be discussed. First there is the direct subscriber-to-subscriber interference. Here the high allowable OOB of cellular subscriber units can cause localized interference around those units when the cellular units are far from their sites (power control doesn't limit the power output) and the LMR unit is far from its desired signal. Figure 21 shows this as the light green blotches associated with the fringe of the cell sites.

The use of CDMA subscriber units is more worrisome as multiple units can be transmitting simultaneously on the same wideband frequency. Often a large population of cellular users coincident with a major public safety event can occur. Now the large population of subscribers in close proximity both in frequency and distance can increase the potential for interference. In addition, if the public safety event is close to a cellular site and a large population of cellular subscribers occurs, then there is also the opportunity for receiver IM to occur. In a documented case in Canada⁵, intermittent interference occurred to the direct mode of fire fighter portables. See Figure 28, where the green locations represent LMR subscribers trying to receive a weak desired signal while Cellular subscribers are at full power due to their distance from their site.

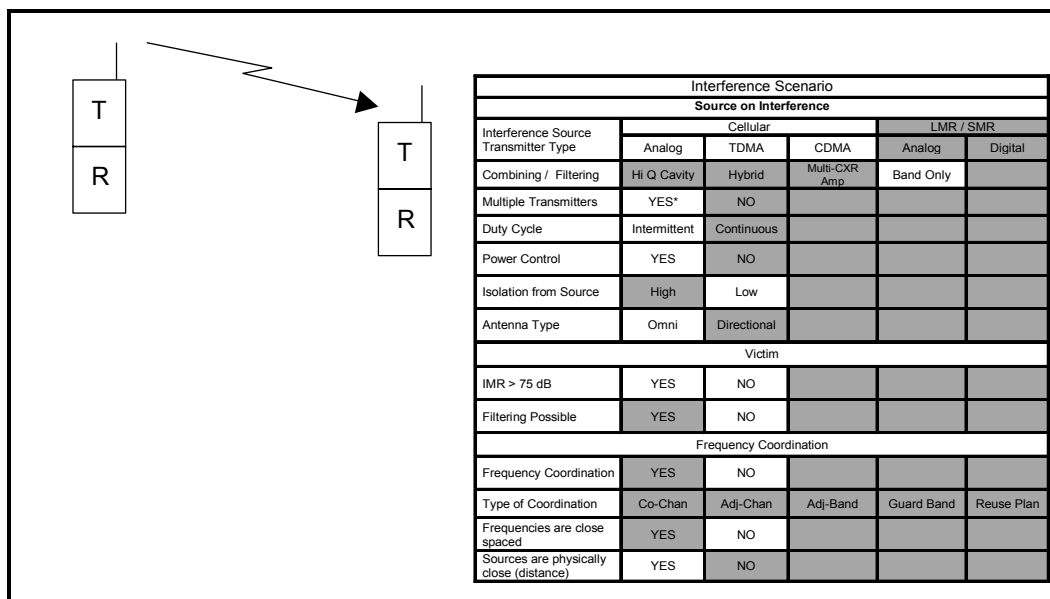

Figure 28 - Case 5, Cellular Subscriber to LMR Subscriber

⁵ Industry Canada, "Analysis into Potential Interference from Out-of-Band Emissions to Public Safety Operations in the 821-824/866-869 MHz Band", December 4, 1998.

11.9 Case 6, Subscriber to LMR Base

Case 6 involves interference from subscriber units to LMR base receivers (Figure 29 & Figure 30). Again this is a classic Near/Far scenario. Receiver voting in the LMR system is the best defense for this type of interference, recognizing that for analog systems strong interference can be misinterpreted as a desired signal. Proper use of sub-audible codes can mitigate the undesired voting potential with the voting offering the decreased likelihood that multiple interfering scenarios occur simultaneously.

Case 6a involves the in-band LMR case. In many systems, TTA's are used to increase sensitivity for fringe talk-in. However, this also increases the susceptibility to interference. A special case is where the LMR subscriber is a control station. This can produce the example of system cross talk and temporary lockup previously described. The area of maximum impact is a reduction in the base talk-in coverage.

Case 6b is the cellular case. Here subscriber units have power control so they would have minimal impact if the cellular site and LMR sites are co-located.

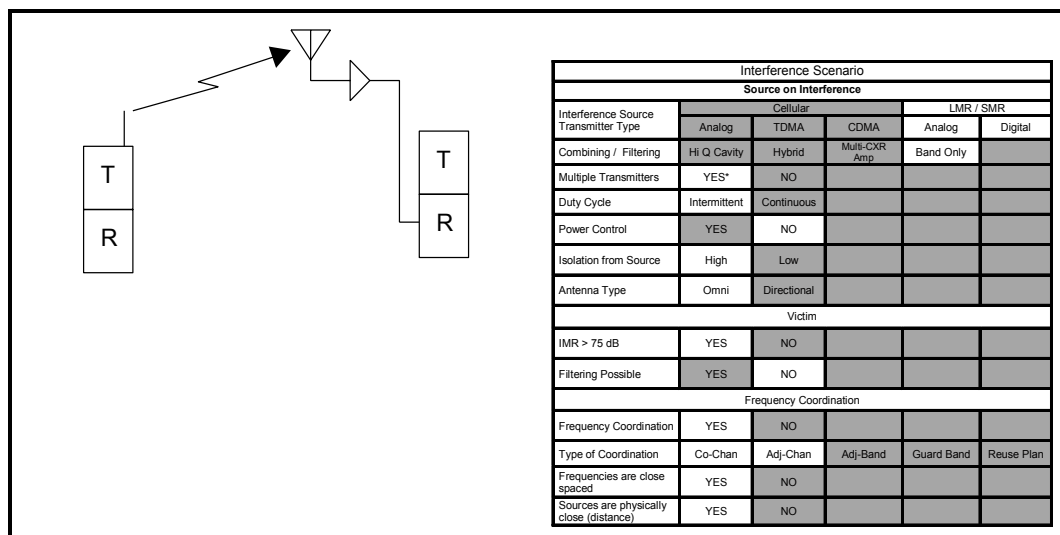

Figure 29 - Case 6a, LMR Subscriber to LMR Base

The use of macro diversity (voting) is the best tool for the prevention of this type of interference.

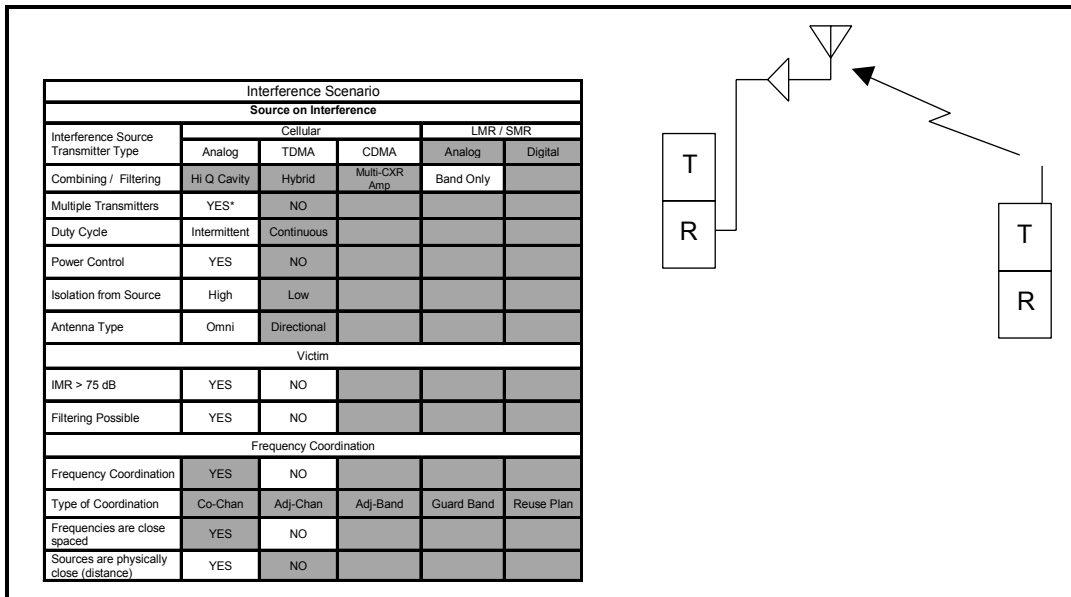

Figure 30 - Case 6b, Cellular Subscriber to LMR Base

Figure 31 - Co-Located Cellular System and LMR System depicts a special case where the cellular system and LMR system are co-located. This essentially minimizes the size of the reduced coverage. If a LMR site were at the junction of three cells, then the potential for multiple interferers transmitting at maximum output power would produce a much worse case. Fixed cellular units, similar to LMR control stations are also a potential problem. In this case the small red diamonds represent the cellular type deployment of sites.

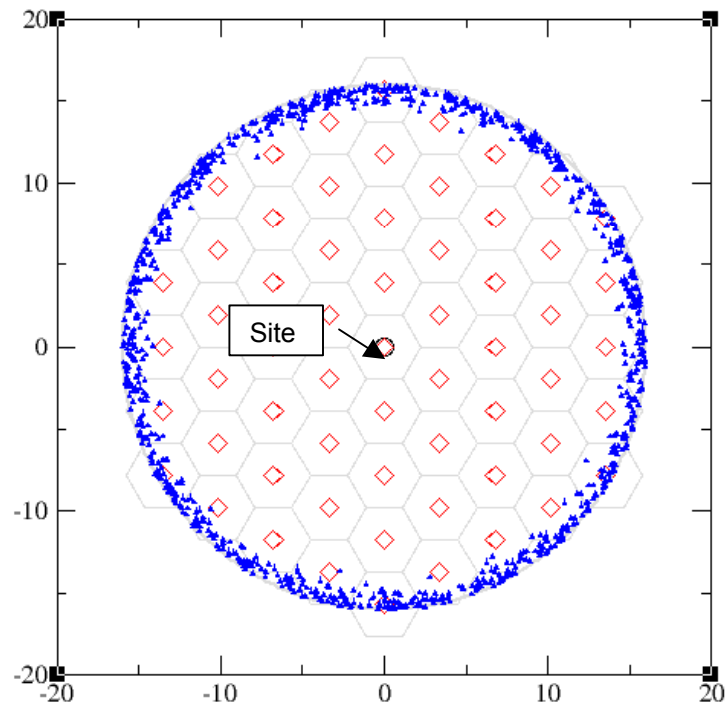

Figure 31 - Co-Located Cellular System and LMR System

12.0 SITE ISOLATION

This section is heavily revised over earlier releases due to more recent evidence of very strong interfering signal levels.

12.1 Definition

As described earlier, there are two ways of predicting the signal losses between a base station and a subscriber unit at close distances. The antenna patterns aren't completely formed and in many cases there are little to no obstructions to increase the losses over Free Space loss.

Path loss is used to define the reduction in field strength as a signal moves further away from its' antenna launching point and is spread out over an ever increasing surface area. Path loss at these relatively short distances is Free Space and can be computed from the Equation

$$\text{Free Space loss between } \frac{\lambda}{2} \text{ dipole antennas (dB)} = 32.2 + 20\text{Log}_{10}(f_{(MHz)}) + 20\text{Log}_{10}(d_{(ft)}) \text{ dB.}$$

The total loss is the sum of the Free Space Loss, offset by the gain of the transmit and the receive antennas. However, only an isotropic antenna theoretically transmits (or receives) energy perfectly in all directions. As gain is created in an antenna, the energy is redirected such that it is concentrated into directional beams. Thus, at any given point, the total signal loss is a function of the distance and the antenna pattern gain to that location.

In the land mobile industry, antennas are normally referenced to a half wave $\left(\frac{\lambda}{2}\right)$ dipole antenna. To achieve gain, the energy has to be launched from multiple segments and shaped into the desired beam pattern. Omni-directional antennas achieve their gain by distributing the energy amongst linear radiators that will sum the desired energy into a narrow vertical beam in all directions. This gain is achieved by minimizing the energy that would normally go in other vertical directions. This results in gain in the main beam (at the horizon), and loss in other slant directions.

Directional antennas achieve gain in a similar method, but also redirect the energy that would go in an undesired direction of the main beam such that it reinforces the energy in the desired direction. As a result, directional antennas of a given vertical dimension have greater gain than omni directional antennas. They also have wider vertical beamwidths for the same reference gain.

Site isolation combines the loss due to increasing distance and includes the patterns of the transmit and the receive antennas. It also makes the determination of the interfering energy easier as the Site isolation is the difference (dB) between the power into the base of the transmit antenna and the energy at the base of the receive antenna.

Figure 32 shows how these three elements combine to determine the Site Isolation value.

- Free Space Path Loss along diagonal (slant) distance (dB)
- Transmit Antenna Pattern, Gain or Loss (dBd)
- Receive Antenna Pattern, Gain or Loss (dBd). Assumed to be a half wave dipole for this evaluation.

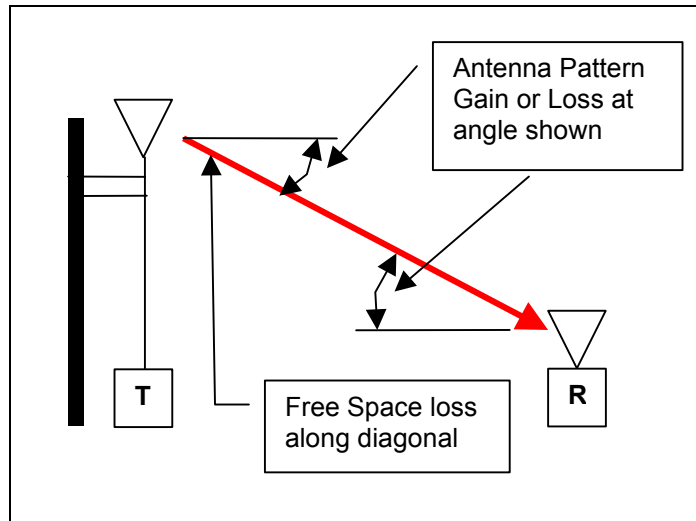

Figure 32 - Example of Site Isolation Components

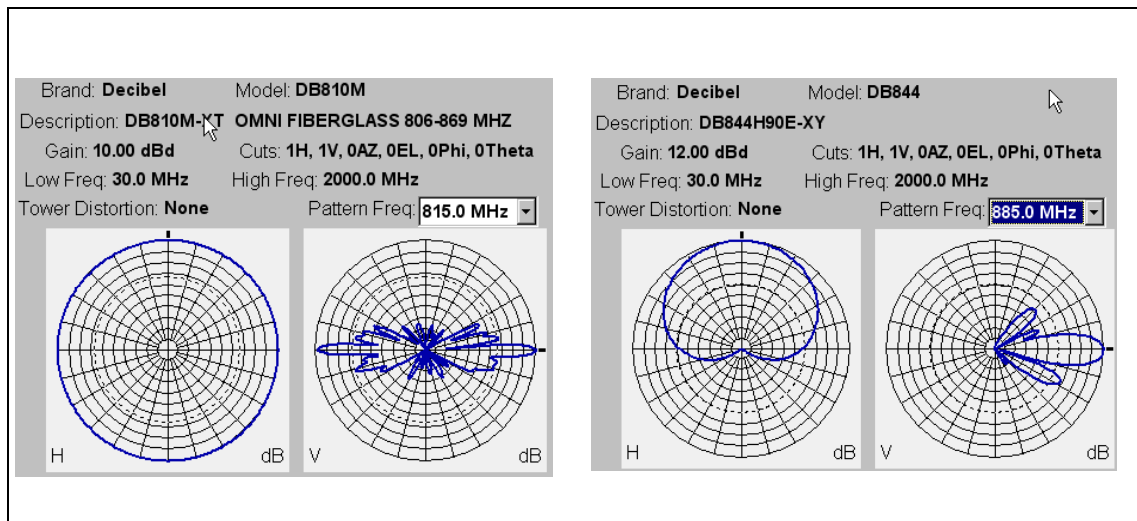

Figure 33 - Base Station, Omni-directional and Directional, Antenna Pattern Examples

As can be seen in Figure 32 when the included angles are steep, there is considerable isolation due to the losses in the antenna patterns. The portable antenna is defined as a vertically polarized half wave dipole for the purpose of these calculations. The pattern of a portable is affected by the antenna, body absorption of the user and polarization variations due to its orientation relative to true vertical polarization.

The results of the different tower height scenarios have been combined to graph the worst case isolation. This worst case isolation will occur at different exact distances. Several examples are included as Figures to demonstrate this affect. The directional antenna provides less site isolation due to its wider beam width even though it has higher gain.

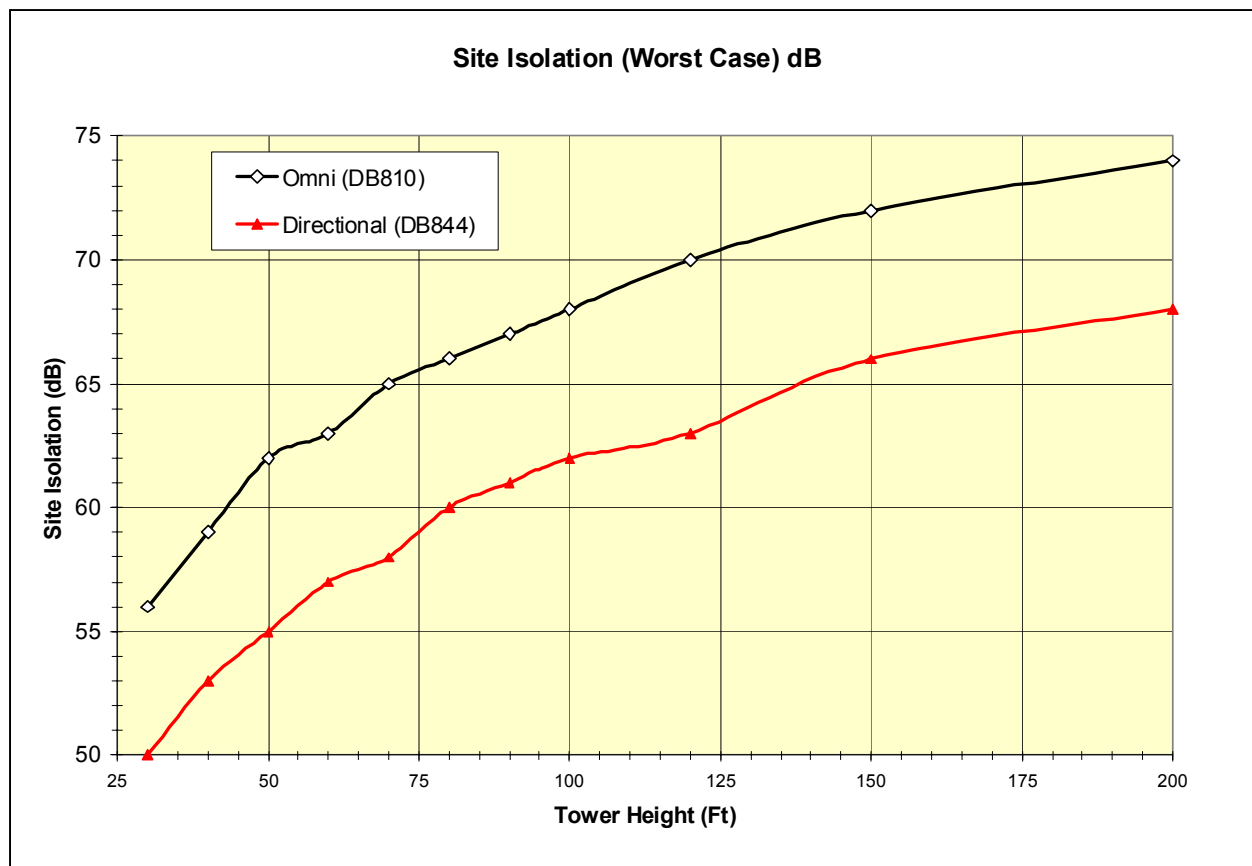

Figure 34 - Worst Case Site Isolation Vs. Tower Height

The simulations for a tower height, more accurately stated as the center of radiation of the antenna above ground level, is shown for the different antenna types for 100 feet.

The worst case isolation doesn't occur at the same distance. However, the exact distance is of little concern when generalizing the scenarios. The deep nulls will fill in due to local reflective scattering so the worst case is more likely to occur than the more optimistic deep nulls that are predicted.

12.2 Down-tilt Antennas

The use of down tilting of antennas even further reduces site isolation, resulting in extremely strong interfering signal levels in close proximity to sites. Phasing of the various radiating antenna elements normally electrically tilts omni-directional antennas. This produces a uniform tilt angle in all horizontal directions. Directional antennas are normally physically tilted. Adjustments to the mounting brackets provide this capability. As a result the amount of down tilt is easily adjusted in the field. When high gain directional antennas are excessively tilted, the affect is even more dramatic than predicted in Figure 36.

The trend in the industry is to use directional antennas with down tilt on short towers or on low buildings. A quick tour locally produced the following pictures of some typical sites. In many cases, the sites are very close to each other, which increases the potential for intermodulation type interference. FCC rules do not account for the concentration of signal levels close to sites. The FCC only considers ERP.

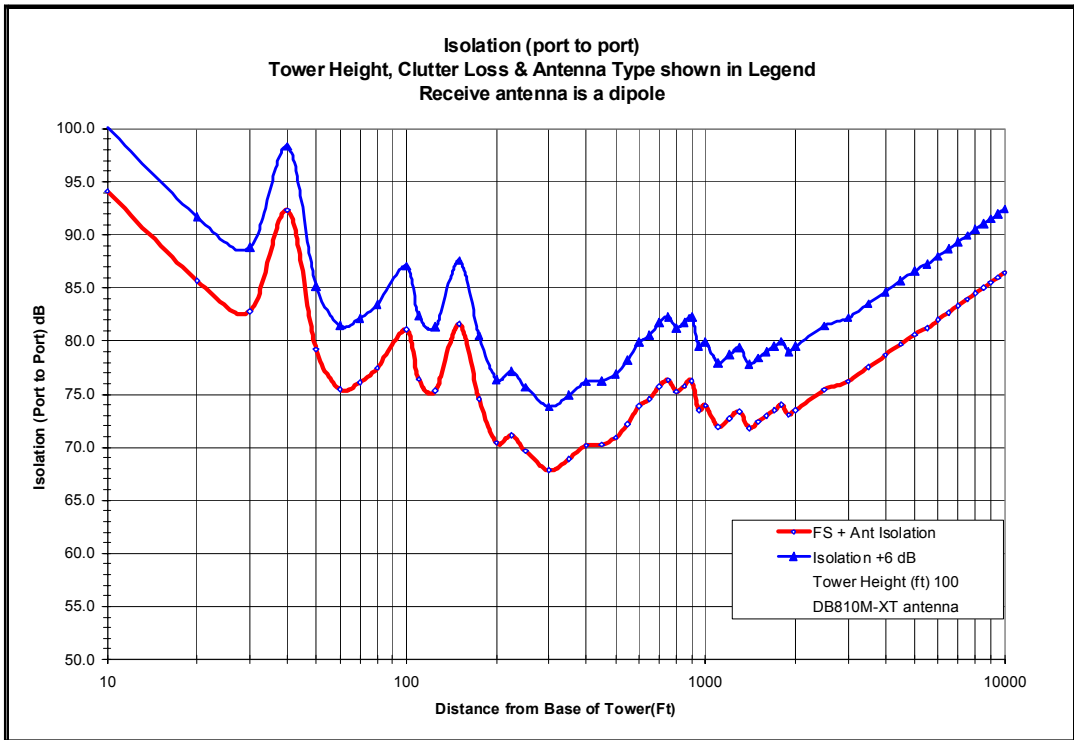

Figure 35 - 10 dB Omni-directional Antenna Site Isolation

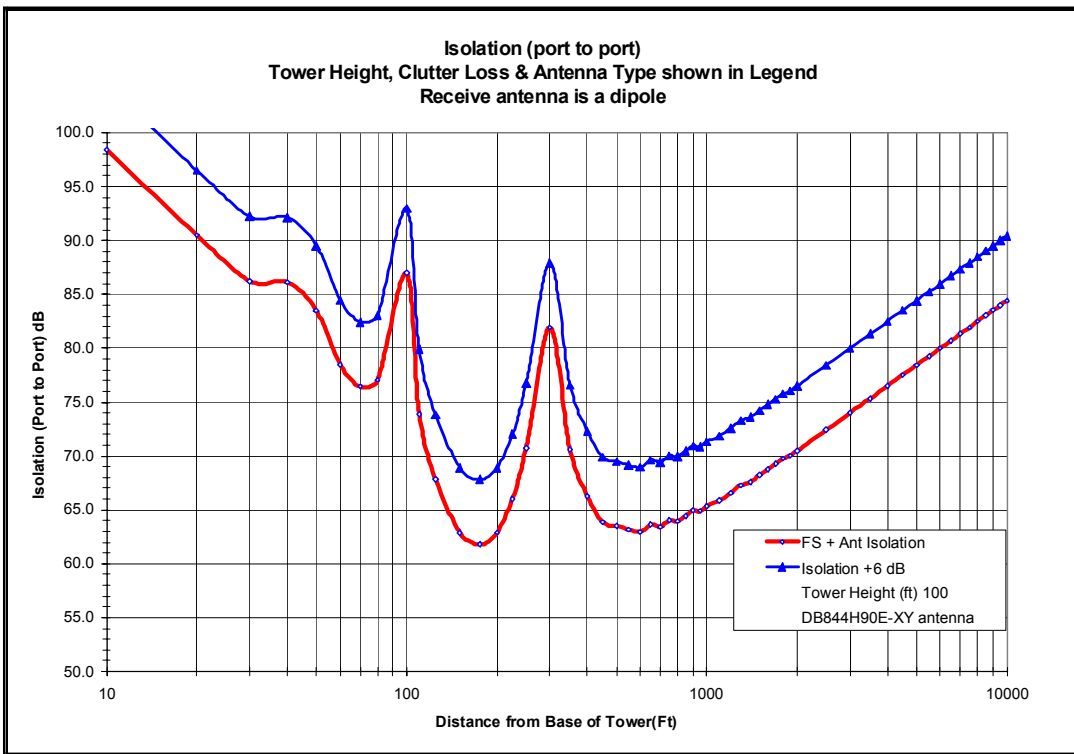

Figure 36 - 12 dBd Directional Antenna Site Isolation

12.3 Site Photographs



Figure 37 - 40 Ft Tower with Down Tilted Directional Antennas



Figure 38 -Directional Antennas On One Story Building



Figure 39 - Adjacent Building. Down Tilt Antennas



Figure 40 - Directional Antenna Site on Power Pole

As the photographs show, antenna heights are now much lower than in the past and antenna tilting to control intrasystem co-channel interference and increase local signal strengths is much more common.

13.0 RESOLVING INTERFERENCE

The following sections describe actions that can be taken to minimize Radio Frequency Interference (RFI) between systems operating at 800 MHz within the same geographical location. These guidelines are general in nature and these same techniques and philosophies can be applied to most any systems experiencing RFI. Thorough testing will determine actual causes (in some cases, multiple causes) and sources of interference that the system is experiencing. Therefore, thorough testing should precede and follow the application of any solutions proposed below to determine the appropriate actions required and the effectiveness of the deployed solution.

13.1 Recommended Resolution Process:

- A. Identify performance issue as RF Interference.
- B. Identify potential source(s) of the interference.
- C. Contact other system operators to cooperatively identify the interference issue. The correct and accurate assessment of the interference mechanism is critical to developing an action plan that will rectify the situation.
- D. FCC rules stipulate that the two system licensees must work cooperatively to resolve any reports of interference.
- E. Implement required changes.
- F. Monitor performance.
- G. Maintain communications with other operators as the site/system evolves.

13.2 Methods to Reduce Interference of Specific Types

13.2.1 Possible actions to reduce the effects of transmitter sideband noise.

- A. Verify interfering systems are within the maximum ERP allowed by FCC license.
- B. Change site frequencies to increase frequency spacing between the source and victim channels.
- C. Swap licensed frequencies or segregate spectrum. These alternatives would require FCC approval.
- D. Lower the interfering transmitter's power as much as possible. This can reduce coverage and move traffic to surrounding sites if there is sufficient coverage overlap. The resulting reduction in carried load may allow a reduction in the number of transmitters that will also reduce the noise floor rise due to transmitter sideband noise.
- E. Increasing the center of radiation on the undesired transmit antennas, > 80' AGL, this will increase the local site isolation to the affected units.
- F. Change antennas in an attempt to reduce the undesired signal level in the immediate area of a site. This may require a change of antenna pattern or the elimination of antenna down-tilt, thereby producing less energy in the antenna's lower lobes. A higher gain (narrower vertical beamwidth) with lowered transmitter power can produce the same ERP while decreasing near-by interfering levels.
- G. Increase desired signal level. This may be accomplished by increasing desired ERP (more power or higher gain antennas) or adding desired sites.
- H. Co-locating sites will maximize the desired signal strength where the undesired energy is strongest.

- I. Use cavity combiners instead of hybrid combiners. Use cavity combiners when the recommended tests have demonstrated that they will help. Note that some auto-tune cavity combiners may not work properly with iDEN's Quad-QAM modulation.
- J. Escalate the construction of new sites in surrounding areas to allow further reduction in ERP.

13.2.2 Possible Actions To Reduce The Effects Of Portable Receiver IM

- A. Increase desired signal strength by adding sites or changing antennas.
- B. Avoid using portables with an IM specification < 74 dB. Portables with higher IM specifications are much more immune to IM interference.
- C. Design Public Safety systems for portable in-building coverage. This will produce higher desired signal levels "on-the-street", overriding IM interference where it is more likely to occur - on the street near low sites. (The undesired signal strengths are attenuated inside buildings and the strength of the IM mix is typically insufficient to interfere with the desired signal.) This may allow portables with lower IM specifications (i.e. $IM \leq 70$ dB) to be utilized.
- D. Determine the frequencies being used by each operator. Attempt to coordinate, to prevent creating 3rd and 5th order Intermodulation (IM) products on protected channels in their identified service areas. Proactively monitor the frequency plan so that IM products are routinely checked for, prior to implementing changes.
- E. Reduce the ERP of the undesired transmit channels as much as possible. A 1 dB reduction in ERP will reduce 3rd order products by 3 dB and 5th order products by 5dB. This reduction in ERP is likely to reduce the number of transmitters that can contribute to mixes as the traffic is offloaded to surrounding sites.
- F. Change portable antennas on victim receivers. Reduce portable antenna gain if there is sufficient desired signal. Each 1 dB reduction in gain will reduce 3rd order products in the receiver front-end by 3 dB and 5th order products by 5 dB. Although the desired signal is reduced, the net effect is a 2 dB or 4 dB improvement in the $C/(I+N)$ respectively.
- G. Use voting receivers to minimize the impact of portable interference to base receivers.
- H. Sweep the transmitter's antenna system or check the tuning on the combiners to reduce transmitter generated IM.
- I. Swap frequencies or segregate spectrum. These alternatives would require FCC approval. Consolidated spectrum would tend to create tightly clumped IM products. Existing interlaced frequency allocations spread out the IM products across much of the band.

13.2.3 Possible Actions To Reduce The Possibility Of Interference In The Future

- A. Maintain constant communication between license holders to coordinate frequency deployments and system expansion plans and actions.
- B. Co-locate sites whenever possible.
- C. Swap frequencies between entities to remove interlaced frequency assignments - requires FCC approval.
- D. Segregate frequencies into sub-bands and either minimize use of frequencies at sub-band edge or establish guard bands between sub-bands.

13.3 Interference reduction methods

The following section describes in more detail various methods for minimizing or eliminating interference. Frequently the interference may not be totally eliminated, but is reduced to levels where acceptable communications can be maintained or relocated to an area where it is less disruptive.

Multiple methods may be employed. One method may reduce a certain kind of interference and then a different type of interference may then be revealed, e.g. if IM is eliminated, then OOB noise may be discovered at a level that was obscured by the stronger mechanism. Only thorough testing will completely characterize the interference types that are occurring in any given situation. The “best” solution for any given case will depend on many factors including the individual circumstances of the location. What worked in one case may not work as well in another case. For example, a change of frequencies in one case may not be possible in another case.

The following options are offered as a menu of possible solutions. The optimal applications of the various solutions will be determined by the specific details of each situation.

13.3.1 Change Frequency Pairs

Changing frequencies is a relatively easy solution to avoid Side Band Noise (SBN), Out of Band Emissions (OOBE) and Intermodulation (IM) interference, if this flexibility exists is an option. Changing frequencies in a cellular type frequency reuse system creates multiple effects that can ripple across many sites if not the entire service area.

Increase the frequency spacing between source and victim channels to reduce SBN and OOBE issues. Moving one or more close spaced frequencies can reduce the amount of noise that can fall in these nearby channels. Frequency spacings of ≥ 150 kHz permit the use of transmitter cavity combiners. Greater frequency spacings generally offer increased protection.

Changing transmit frequencies involved in an IM product can be used to move the mix to a channel that is not used in the area or to a frequency that is more immune to the IM product. Receiver frequencies can be moved from channels where IM mixes occur. When frequency plans are dynamic (changed frequently) proactively evaluate changes before implementing.

In some cases an exchange of frequencies between licensees is another possibility where and when this is permitted. Ideally, a segregation of frequency utilization into sub-bands offers greater protection relative to situations where frequency assignments are interlaced as occurs in the middle of the band. IM may be generated, but it is more likely to be within ones own sub-band where the system design can mitigate it. IM products generated at the source that fall outside the sub-band can be filtered.

13.3.2 Reduce ERP Or Signal Strength Of The Undesired Signal

Reduce the signal strength of undesired signal(s) is a way to reduce interference. This may be difficult, as the degree of reduction required may have a negative performance impact on those channels. When possible, this can be a very effective solution. When IM is the mechanism, the leverage of reducing the effect by the order of the IM magnitude is very powerful.

In some cases the reduction may be aimed solely at the SBN / OOBE energy on a specific or set of channels. In other cases, a reduction in the radiated power of the main carrier is required.

Adding filters (typically high Q cavity filters) between a transmitter and the antenna may be used to reduce the energy radiated into other offset channels. Cavity filters typically offer little reduction within ± 150 kHz of the carrier frequency. Cavity filters will typically offer more protection at increasing frequency

separations. Ceramic “auto-tune” cavity filters and combiners provide higher Q filters while offering flexibility to change frequencies when needed. Note that some auto-tune cavities may not function with iDEN modulation, consult manufacturers for additional information.

Lowering transmitter ERP can help control both emitted noise levels as well as the power in an IM mix. Due to the nature of IM interference, a 1 dB reduction in ERP on frequencies involved in a 3rd order mix can reduce the IM product level inside a victim portable receiver by 3 dB. For 5th order mixes, the same 1 dB reduction can reduce the IM level by 5 dB. A 1 to 2 dB reduction in transmitter ERP may be enough to reduce the IM levels to more acceptable levels. A reduction in transmit ERP may reduce the size of a cell and the traffic carrying capacity of that cell. A drop in offered load may also allow one or two transmitters to be turned off, thereby decreasing the interference potential of that cell.

ERP can be simply reduced by reducing each transmitter’s output power. This change affects the entire cell. A more selective way to change all ERPs at a specific location is to change the antenna gain and its pattern. The area where a reduction is desired may be a specific spot or it may be the area within a certain distance of the site. Increasing antenna gain with a corresponding reduction in output power, reducing antenna down-tilt, or using an antenna with greater lobe reduction can, separately or combined, be used to reduce the signal strength near a site where there is excessive signal strength.

There are several more creative ways to reduce IM interference by reducing the levels of the signals involved in the process. A portable with increased immunity against the IM products is one of the best methods of protecting oneself from IM interference no matter what the sources are. Such a portable generally has better all around performance and the added expense is well worth the investment, especially given the growth in wireless and the increased chances of operating near other wireless devices. A portable with an IM spec of 75 dB or greater has greater protection against IM in studied and expected scenarios, particularly where in-building coverage is also provided. Receiver specification improvements beyond 75 dB typically require a substantial increase in battery drain. That is why mobile and base station radios tend to have better IM performance than portables.

Oddly enough, using a lower gain antenna on a portable that is experiencing IM interference is one way to lower the amount of undesired signal reaching a portable receiver’s front-end. This lowers the desired signal a few dB but reduces the IM products by the order of the product times the number of dB reduction. This then creates a better C/(I+N) ratio. This can be an effective solution when there is sufficient desired signal strength and the interference is due to intermodulation. Note that a lower gain antenna may reduce the portables’ effective range in other situations.

Another method to decrease an undesired signal’s impact is to increase the distance between the source and victim. Path loss increases logarithmically with distance. Distance also changes the amount of gain in the antenna pattern. Increased antenna heights with decreased ERP increase site isolation and produce the similar coverage. Raising the center of radiation of transmit antennas can reduce interference. Zoning rules and aesthetic are forcing antennas to lower levels and there may be “stealth” sites behind store-front facades and many more low antenna sites. A more conventional tower or building installation provides increased protection from RFI. Note that increasing demands for wireless services is a factor resulting in more sites that are heavily loaded. Frequency reuse can be enhanced when sites are deployed below tree top or building top levels.

Lowering the ERP and reducing the number of transmitters on any one site may shrink the coverage area of a given cell and off load traffic to surrounding cells. Adding additional cells (otherwise known as cell splitting) adjacent to a cell is one way to accommodate these reductions while maintaining offered service levels.

Regularly sweeping transmission lines and antennas at sites to find transmitted IM (IM) is required to insure legal operation. Reducing transmitted IM levels and maintaining low radiated IM levels is an effective method to reduce the possibility of interference of this type.

13.3.3 Increase ERP Or Signal Strength Of Desired Signal

A number of methods exist for reducing or eliminating interference by increasing the desired signal level. This method can override many forms of interference including noise and receiver IM in weak coverage areas.

It is increasingly common for communications systems users to desire or demand coverage when inside buildings. The mobility of portables requires in-building coverage. Providing in-building coverage will require more sites or equipment but it will also provide protection against many forms of interference. Many of the interference problem areas occur near other sites while the victim is on the street. The building loss can reduce the interference below troublesome levels, especially where IM is occurring in the portable's receiver. Every dB of attenuation to the undesired signal(s) produces a 3 times or 5 times reduction in the level of their IM product.

Increasing the transmitter's output power on desired frequencies can improve the down-link performance by overriding the interference, increasing the $C/(I+N)$. The ERP can also be raised into a particular area by changing the antenna pattern or by increasing antenna gain. Increasing the antenna height above ground level on the desired transmitters can also increase the level of the desired signal.

Adding additional sites on the desired channel(s) is another available option. This has the added benefit of increasing coverage inside buildings. Simulcasting provides enhanced robustness to interference as well as increased reliability, both inside and outside buildings.

Deploying Bi-Directional Amplifiers (BDA) or single channel (channelized) amplifier(s) are also possible ways to improve coverage into specific areas that would benefit from enhanced coverage. A BDA amplifies all signals within a specific band or sub-band, increasing the desired signal inside buildings or into underground facilities such as subways or tunnels. A channelized amplifier only amplifies a specific channel and retransmits it into a contained area. Both have characteristics that need to be understood. A BDA can amplify and retransmit interfering signals as well as desired signals. Careful engineering is required for successful deployment. Channelized amplifiers introduce noticeable delay between the direct and amplified signals. This delay difference can cause coverage problems similar to ghosts in a TV receiver. Both require isolation between the input and output to prevent "feedback" oscillation, where the output signals loops back into the input causing instability. Some channelized repeaters actually can shift the new output frequency from the input frequency. This eliminates the potential for oscillation but the type of system deployment and availability of additional frequencies can limit the application of this type solution.

The co-location of transmitter sites ensures that the desired signal is stronger than any interfering signal. This may not always be possible when mixing systems of different types such as high user density cellular utilizing many low sites and a lower user density two-way radio system utilizing a few high sites. This option reduces talk-out interference but it can increase talk-in interference, requiring "voting" receivers to minimize this effect, see Case 6 scenarios.

As previously mentioned, the use of portables with higher performance specifications is another way to reduce the probability of interference. The specifications of interest are the selectivity and IM performance of the radio. Radios with specifications in the area of > 70 dB are needed to offer reasonable protection for use in typical environments where there are high levels of desired RF. Increased protection is offered by improved specifications, as qualified by Figure 7 where the spectral purity of the source must also be considered.

Increasing the desired signal strength is an effective method for minimizing interference and these choices should be considered as alternatives in most cases.

13.3.4 Long Term Avoidance

Long term strategies for minimizing or eliminating interference may involve an exchange of frequencies or a segregation of frequencies to move the operations of different system types to their own and separate spectrum allocation(s). Recently a white paper from Nextel⁶ was sent to the FCC, proposing a band reorganization to separate noise limited and interference limited systems. It is not the purpose of this paper to comment on this proposal. There are numerous issues that need to be resolved.

It is anticipated that the FCC will issue a notice on this issue in the first quarter of 2002.

Segregating frequencies would separate system types into different sub-bands and offer each service a higher level of protection against interference. There still may be some interference where the sub-bands are located next to each other, or have deployments of very complex or “noisy” modulation, but the interference in such cases would be easier to predict, identify and create an engineered solution when it does occur. To fully realize the benefits of segregating band segments, equipment redesigns may be required and over the long term, the retirement of older radios that are statically configured for the original band structure.

Currently, swapping between users, one or more frequency pairs may provide an opportunity to address an individual case or set of cases throughout a small area. Proactively monitoring all changes to prevent interference is still required.

Prevention using the “Best Practices Guidelines”, can really work as demonstrated at the Salt Lake City area 2002 Winter Olympics. Tight coordination prevented interference issues.

⁶ “Promoting Public Safety Communications”, Nextel Communications, 11/21/2001

14.0 ACRONYMS

ACCP	Adjacent Channel Coupled Power
ACCPR	Adjacent Channel Coupled Power Ratio
ACIPR	Adjacent Channel Interference Protection Ratio
ACPR	Adjacent Channel Power Ratio
ACRR	Adjacent Channel Rejection Ratio
AMPS	Advanced Mobile Phone System
C4FM	Compatible 4 level FM
CDMA	Code Division Multiple Access
Cf/N	Faded Carrier to Noise Ratio
CQPSK	Compatible Quadrature Phase Shift Keying
Cs/N	Static Carrier to Noise Ratio
DSP	Digital Signal Processor
EIA	Electronics Industry Association
IDEN™	Integrated Digital Enhanced Network
IF	Intermediate Frequency
IIP ³	Third Order Input Intercept Point
IM	Inter Modulation
IMR	Inter Modulation Receiver
LMR	Land Mobile Radio
LO	Local Oscillator
NAMPS	Narrowband Advanced Mobile Phone System
NPSPAC	National Public Safety Planning & Advisory Committee
Oobe	Out Of Band Emissions
PROM	Programmable Read Only Memory
Q	Figure of Merit for filter selectivity
SBN	Sideband Noise
SMR	Specialized Mobile Radio (Service)
TDMA	Time Division Multiple Access
TIA	Telecommunications Industry Association
TTA	Tower Top Amplifier