

DR-570T/E

Service Manual



Index

●SPECIFICATIONS	2	●UHF PLL, VCO SCHEMATIC DIAGRAM.....	28
●PARTS LIST	3~9	●UHF PLL, VCO PC BOARD	28
●DISASSEMBLING PROCEDURE	10~13	●VOL PC BOARD	29
●CABINET PARTS LOCATION	14	●POWER SUPPLY PC BOARD	29
●ADJUSTMENT (VHF)	15	●CPU SCHEMATIC DIAGRAM	30
●ADJUSTMENT (UHF)	16	●CPU PC BOARD	31
●BLOCK DIAGRAM	17	●CONTROL SCHEMATIC DIAGRAM	32
●SCHEMATIC DIAGRAM	18	●CONTROL PC BOARD	33
●VHF MAIN SCHEMATIC DIAGRAM.....	19, 20	●X'CON SCHEMATIC DIAGRAM	34
●VHF MAIN PC BOARD	21, 22	●X'CON PC BOARD	35
●UHF MAIN SCHEMATIC DIAGRAM	23, 24	●FINAL, DUPLEXER SCHEMATIC DIAGRAM..	36
●UHF MAIN PC BOARD	25, 26	●VHF FINAL PC BOARD	37
●VHF PLL, VCO SCHEMATIC DIAGRAM.....	27	●UHF FINAL PC BOARD	37
●VHF PLL, VCO PC BOARD	27	●CTCSS SCHEMATIC DIAGRAM	38
		●CTCSS PC BOARD	39
		●DUPLEXER PC BOARD	40
		●TONE SQUELCH SCHEMATIC DIAGRAM ..	40

SPECIFICATIONS

■ General

Frequency Coverage	144.00–147.995 MHz (TX), 130–169.995 MHz (RX) 440.00–449.995 MHz (TX) (RX) (U. S. Version) 144.00–145.9875 MHz (TX), 130–169.9875 MHz (RX) 430–440 MHz (Europe Version)
Frequency Resolution	5, 10, 12.5, 20 and 25 kHz, steps
Antenna Impedance	50 ohms unbalanced
Power Supply	
Requirement	13.8 Volts D. C.
Current Drain at 13.8 V	Receiving Squelched: does not exceed 600 mA Transmitting High: 45 W approx. 10.0 A at VHF Low: 5 W approx. 4.0 A at VHF High: 35 W approx. 11.0 A at UHF Low: 5 W approx. 4.0 A at UHF
Dimension	150 mm (W) × 50 mm (H) × 173 mm (D) (5 ⁷ / ₈ " × 2" × 6 ⁷ / ₈ ")
Weight	Approx. 1.6 kgs (3.74 lbs.)

■ Transmitter

Output Power	High: Approx. 45 Watts at VHF, Approx. 35 Watts at UHF Low: Approx. 5 Watts at both bands
Emission Mode	F3 (FM)
Modulation System	Variable Reactance F. M.
Max. Frequency	
Deviation	±5 kHz
Spurious Emission	More than 60 dB below carrier
Microphone	Electret Condenser Microphone
Operating Mode	Simplex Duplex: ±600 kHz from receive frequency at VHF : ±5 MHz from receive frequency at UHF
DTMF Encoder	Built in (DR-570T)

■ Receiver

Receiving System	Superheterodyne, dual Conversion
Modulation acceptance	F3 (FM)
Intermediate Frequency	1st 10.7 MHz 2nd 455 kHz at VHF 1st 30.825 MHz 2nd 455 kHz at UHF
Sensitivity	12 dB SINAD – 16 dB μ
Selectivity	More than ±6 kHz at –6 dB Less than ±12 kHz at –60 dB
Audio Power Output	More than 2.0 ± 0.5 W
Speaker Impedance	8 ohms

■ PARTS LIST

Ref. No.	Part Code	Part Name and Number	Ref. No.	Part Code	Part Name and Number	Ref. No.	Part Code	Part Name and Number
VOL Unit			D2	XD0112	Varicap, 1SV128	R61	RK0076	Chip R, MCR10 330 kΩ
VR1	RV0013	Volume, RK0972211	D3	XD0097	Diode, 1SS268	R62	RK0039	Chip R, MCR10 2.2 kΩ
VR2	RV0012	Volume, RK0972210	D4	XD0100	Varicap, 1SV164	R63	RK0018	Chip R, MCR10 100Ω
Ⓝ	UE0062	Post with Base, PI22B09M	D5	XD0100	Varicap, 1SV164	R64	RK0006	Chip R, MCR10 27Ω
VHF Main Unit			D6	XD0100	Varicap, 1SV164	R65	RK0039	Chip R, MCR10 2.2 kΩ
R1E	RK0054	Chip R, MCR10 15 kΩ (DR-570E only)	D7	XD0100	Varicap, 1SV164	R66	RK0018	Chip R, MCR10 100Ω
R2E	RK0052	Chip R, MCR10 10 kΩ (DR-570E only)	D8	XD0100	Varicap, 1SV164	R67	RK0035	Chip R, MCR10 1 kΩ
R3E	RK0052	Chip R, MCR10 10 kΩ (DR-570E only)	D9	XD0057	Diode, 1SS184	R71	RK0052	Chip R, MCR10 10 kΩ
R4E	RK0052	Chip R, MCR10 10 kΩ (DR-570E only)	D10	XD0103	Diode, 1SS226	R72	RK0052	Chip R, MCR10 10 kΩ
R5E	RK0072	Chip R, MCR10 180 kΩ (DR-570E only)	D11	XD0057	Diode, 1SS184	R73	RK0052	Chip R, MCR10 10 kΩ
R6E	RK0069	Chip R, MCR10 100 kΩ (DR-570E only)	D12	XD0057	Diode, 1SS184	R74	RK0056	Chip R, MCR10 22 kΩ
R7E	RK0039	Chip R, MCR10 2.2 kΩ (DR-570E only)	D13	XD0057	Diode, 1SS184	R75	RK0018	Chip R, MCR10 100Ω
R8E	RK0045	Chip R, MCR10 4.7 kΩ (DR-570E only)	D14	XD0057	Diode, 1SS184	R76	RK0018	Chip R, MCR10 100Ω
R9E	RK0018	Chip R, MCR10 100Ω (DR-570E only)	D15	XD0104	Zener Diode, 02C26.2Y	R77	RK0039	Chip R, MCR10 2.2 kΩ
R10E	RK0086	Chip R, MCR10 1 MΩ (DR-570E only)	D16	XD0097	Diode, 1SS268	R78	RK0035	Chip R, MCR10 1 kΩ
R12E	RK0039	Chip R, MCR10 2.2 kΩ (DR-570E only)	D17	XD0058	Diode, 1SS181	R79	RK0056	Chip R, MCR10 22 kΩ
C1E	CU8002	Chip C, C2012B1H 0.01 μF (DR-570E only)	D18	XD0113	Zener Diode, 02C24.3Y	R80	RK0045	Chip R, MCR10 4.7 kΩ
C2E	CU8002	Chip C, C2012B1H 0.01 μF (DR-570E only)	D19	XD0100	Varicap, 1SV164	R81	RK0014	Chip R, MCR10 68Ω
C3E	CU8002	Chip C, C2012B1H 0.01 μF (DR-570E only)	D20	XD0103	Diode, 1SS226	R82	RK0018	Chip R, MCR10 100Ω
C4E	CU8002	Chip C, C2012B1H 0.01 μF (DR-570E only)	D21	XD0038	Diode, 1SS133	R83	RK0025	Chip R, MCR10 330Ω
C5E	CE0200	Chemical C, UW 50 V 2.2 μF (DR-570E only)	R1	RK0039	Chip R, MCR10 2.2 kΩ	R84	RK0037	Chip R, MCR10 1.5 kΩ
C6E	CS0059	Chip Tantal, TMC0J226 (DR-570E only)	R2	RK0048	Chip R, MCR10 6.8 kΩ	R85	RK0011	Chip R, MCR10 47Ω
C7E	CU8038	Chip C, CM316Y1E 1 μFZ (DR-570E only)	R3	RK0052	Chip R, MCR10 10 kΩ	R86	RK0001	Chip R, MCR10 10Ω
C8E	CE0189	Chemical C, TWSS 100 μF/16 V (DR-570E only)	R4	RK0039	Chip R, MCR10 2.2 kΩ	R87	RK0069	Chip R, MCR10 100 kΩ
IC1E	XA0097	IC, NJM 4558M (DR-570E only)	R5	RK0045	Chip R, MCR10 4.7 kΩ	R88	RK0069	Chip R, MCR10 100 kΩ
IC2E	XA0093	IC, NJU 4069UBM (DR-570E only)	R6	RK0052	Chip R, MCR10 10 kΩ	R89	RK0028	Chip R, MCR10 470Ω
IC3E	XA0092	IC, NJU 4020BM (DR-570E only)	R7	RK0059	Chip R, MCR10 33 kΩ	R90	RK0076	Chip R, MCR10 330 kΩ
Q1E	XU0022	Digital Transistor, DTA114EK (DR-570E only)	R8	RK0018	Chip R, MCR10 100Ω	J1	RK0107	Chip R, MCR10 0Ω
X1E	XB0001	FAR, C4CA03580000K01 (DR-570E only)	R9	RK0052	Chip R, MCR10 10 kΩ	J2	RK1107	Chip R, MCR18 0Ω
CN TB	UE0070	Post with Base, PI22A04M (DR-570E only)	R10	RK0018	Chip R, MCR10 100Ω	J3	RK0107	Chip R, MCR10 0Ω
IC1	XA0070	IC, MC3361D	R11	RK0069	Chip R, MCR10 100 kΩ	C1	CU8001	Chip C, C2012B1H 0.001 μF
IC2	XA0079	IC, μPC1241H	R12	RK0069	Chip R, MCR10 100 kΩ	C2	CU8001	Chip C, C2012B1H 0.001 μF
IC3	XA0091	IC, TMA247	R13	RK0069	Chip R, MCR10 100 kΩ	C3	CU8001	Chip C, C2012B1H 0.001 μF
Q1	XE0013	FET, 3SK184S	R14	RK0069	Chip R, MCR10 100 kΩ	C4	CU8001	Chip C, C2012B1H 0.001 μF
Q2	XE0017	FET, 3SK179L	R15	RK0035	Chip R, MCR10 1 kΩ	C5	CU8001	Chip C, C2012B1H 0.001 μF
Q3	XT0081	Transistor, 2SC2714Y	R16	RK0062	Chip R, MCR10 47 kΩ	C6	CU0027	Chip C, C2012CH1H 47 pF
Q4	XT0031	Transistor, 2SC2712Y	R17	RK0045	Chip R, MCR10 4.7 kΩ	C7	CU8001	Chip C, C2012B1H 0.001 μF
Q5	XT0031	Transistor, 2SC2712Y	R18	RK0011	Chip R, MCR10 47Ω	C8	CU8001	Chip C, C2012B1H 0.001 μF
Q7	XT0031	Transistor, 2SC2712Y	R19	RK0074	Chip R, MCR10 270 kΩ	C9	CU8001	Chip C, C2012B1H 0.001 μF
Q8	XT0031	Transistor, 2SC2712Y	R20	RK0018	Chip R, MCR10 100Ω	C10	CU8002	Chip C, C2012B1H 0.01 μF
Q9	XT0031	Transistor, 2SC2712Y	R21	RK0039	Chip R, MCR10 2.2 kΩ	C11	CU8001	Chip C, C2012B1H 0.001 μF
Q10	XT0061	Transistor, 2SB1132Q	R22	RK0042	Chip R, MCR10 3.3 kΩ	C12	CU8001	Chip C, C2012B1H 0.001 μF
Q11	XT0061	Transistor, 2SB1132Q	R23	RK0038	Chip R, MCR10 1.8 kΩ	C14	CU0001	Chip C, C2012CH1H 0.5 pF
Q12	XU0012	Digital Transistor, DTC114EK	R24	RK0038	Chip R, MCR10 1.8 kΩ	C15	CU0029	Chip C, C2012CH1H 56 pF
Q13	XT0081	Transistor, 2SC2714Y	R25	RK0018	Chip R, MCR10 100Ω	C16	CU0001	Chip C, C2012CH1H 0.5 pF
Q14	XT0081	Transistor, 2SC2714Y	R26	RK0045	Chip R, MCR10 4.7 kΩ	C17	CU0029	Chip C, C2012CH1H 56 pF
Q15	XT0081	Transistor, 2SC2714Y	R27	RK0076	Chip R, MCR10 330 kΩ	C18	CU8002	Chip C, C2012B1H 0.001 μF
Q16	XU0022	Digital Transistor, DTA114EK	R28	RK0035	Chip R, MCR10 1 kΩ	C19	CU0035	Chip C, C2012CH1H 100 pF
Q17	XT0077	Transistor, 2SC3326A	R29	RK0065	Chip R, MCR10 68 kΩ	C20	CU0011	Chip C, C2012CH1H 5 pF
Q18	XT0030	Transistor, 2SC3356	R30	RK0059	Chip R, MCR10 33 kΩ	C21	CU8001	Chip C, C2012B1H 0.001 μF
Q19	XT0081	Transistor, 2SC2714Y	R31	RK0042	Chip R, MCR10 3.3 kΩ	C22	CU8001	Chip C, C2012B1H 0.001 μF
Q20	XT0084	Transistor, 2SC2954	R32	RK0048	Chip R, MCR10 6.8 kΩ	C23	CU8001	Chip C, C2012B1H 0.001 μF
Q21	XU0003	Digital Transistor, DTC114TK	R33	RK0076	Chip R, MCR10 330 kΩ	C24	CU0004	Chip C, C2012CH1H 3 pF
D1	XD0057	Diode, 1SS184	R34	RK0076	Chip R, MCR10 330 kΩ	C25	CU0015	Chip C, C2012CH1H 15 pF
			R35	RK0044	Chip R, MCR10 3.9 kΩ	C26	CU8001	Chip C, C2012B1H 0.001 μF
			R36	RK0076	Chip R, MCR10 330 kΩ	C27	CU8001	Chip C, C2012B1H 0.001 μF
			R37	RK0044	Chip R, MCR10 3.9 kΩ	C28	CU8001	Chip C, C2012B1H 0.001 μF
			R38	RK0028	Chip R, MCR10 470Ω	C29	CU0025	Chip C, C2012CH1H 39 pF
			R39	RK0052	Chip R, MCR10 10 kΩ	C30	CU0035	Chip C, C2012CH1H 100 pF
			R40	RK0069	Chip R, MCR10 100 kΩ	C31	CU8003	Chip C, C2012B1H 0.1 μF
			R41	RK0035	Chip R, MCR10 1 kΩ	C32	CU8003	Chip C, C2012B1H 0.1 μF
			R42	RK0025	Chip R, MCR10 330Ω	C33	CU8005	Chip C, C2012B1H 0.0022 μF
			R43	RK0106	Chip R, MCR10 3.3Ω	C34	CU8003	Chip C, C2012B1H 0.1 μF
			R44	RK0056	Chip R, MCR10 22 kΩ	C35	CU8006	Chip C, C2012B1E 0.022 μF
			R45	RK0076	Chip R, MCR10 330 kΩ	C36	CU0035	Chip C, C2012CH1H 100 pF
			R46	RK0056	Chip R, MCR10 22 kΩ	C37	CU8001	Chip C, C2012B1H 0.001 μF
			R47	RK0076	Chip R, MCR10 330 kΩ	C38	CU8002	Chip C, C2012B1H 0.01 μF
			R48	RK0056	Chip R, MCR10 22 kΩ	C39	CS0060	Chip Tantal, TMC1E474
			R49	RK0062	Chip R, MCR10 47 kΩ	C40	CE0188	Chemical C, TWSS 47 μF/16 V
			R50	RK0052	Chip R, MCR10 10 kΩ	C41	CU8003	Chip C, C2012B1H 0.1 μF
			R51	RK0052	Chip R, MCR10 10 kΩ	C42	CU8001	Chip C, C2012B1H 0.001 μF
			R52	RK0038	Chip R, MCR10 1.8 kΩ	C43	CU8001	Chip C, C2012B1H 0.001 μF
			R53	RK0038	Chip R, MCR10 1.8 kΩ	C44	CU8001	Chip C, C2012B1H 0.001 μF
			R54	RK0052	Chip R, MCR10 10 kΩ	C45	CU8006	Chip C, C2012B1E 0.022 μF
			R55	RK0062	Chip R, MCR10 47 kΩ	C46	CU8001	Chip C, C2012B1H 0.001 μF
			R56	RK0062	Chip R, MCR10 47 kΩ			
			R57	RK0052	Chip R, MCR10 10 kΩ			
			R58	RK0056	Chip R, MCR10 22 kΩ			
			R59	RK0035	Chip R, MCR10 1 kΩ			
			R60	RK0018	Chip R, MCR10 100Ω			

Ref. No.	Part Code	Part Name and Number	Ref. No.	Part Code	Part Name and Number	Ref. No.	Part Code	Part Name and Number		
C47	CU8002	Chip C, C2012B1H 0.01 µF	L13	QC0067	Chip Coil, NL322522T-R10M	Q3	XE0013	FET, 3SK 184S		
C48	CE0189	Chemical C, TWSS 100 µF/16 V	L14	QC0062	Chip Coil, NL322522T-039M	Q4	XT0081	Transistor, 2SC2714Y		
C49	CE0188	Chemical C, TWSS 47 µF/16 V	CF1	XC0001	Ceramic Filter, CFW455F	Q5	XT0031	Transistor, 2SC2712Y		
C50	CE0188	Chemical C, TWSS 47 µF/16 V	XF1	XF0004	X'tal Filter, 49/U 10.7 MHz	Q6	XT0031	Transistor, 2SC2712Y		
C52	CE0188	Chemical C, TWSS 47 µF/16 V	X1	XQ0033	X'tal, 49/U 10.245 MHz	Q7	XT0017	Transistor, 2SA1162Y		
C55	CU8003	Chip C, C2012B1H 0.1 µF	X2	XQ0038	X'tal, HC-49/U 12.8 MHz	Q8	XT0041	Transistor, FMW1		
C56	CU8034	Chip C, C2012B1E 0.033 µF	TH1	XS0004	Thermistor, TD5150D	Q9	XT0041	Transistor, FMW1		
C57	CU8001	Chip C, C2012B1H 0.001 µF		TT1001	Elastic Tube, Ø0.7×10 mm	Q10	XT0031	Transistor, 2SC2712Y		
C58	CE0188	Chemical C, TWSS 47 µF/16 V		TZ0030A	Insulating Paper, UM-2 type	Q11	XT0031	Transistor, 2SC2712Y		
C59	CE0181	Chemical C, TWSS 470 µF/10 V	TC1	CT0028	Trimmer C, ECRJA006A12	Q12	XT0087	Transistor, 2SC2759U23		
C61	CS0065	Chip Tantal, TMC1D684	VR1	RH0054	VR, CVR-42A-224AW1D	Q13	XT0077	Transistor, 2SC3326A		
C62	CS0065	Chip Tantal, TMC1D684	VR2	RH0037	VR, CVR-42A-471AW1D	Q14	XU0012	Digital Transistor, DTC114EK		
C63	CS0049	Chip Tantal, TMC1C105	VR3	RH0031	VR, CVR-42A-103AW1D	Q15	XT0087	Transistor, 2SC2759U23		
C64	CU8001	Chip C, C2012B1H 0.001 µF		UE0043	Post with Base, PI22A02M	Q16	XT0048	Transistor, 2SC3357		
C65	CU0019	Chip C, C2012CH1H 22 pF		UE0043	Post with Base, PI22A02M	Q17	XT0078	Transistor, 2SC3369		
C66	CU0035	Chip C, C2012CH1H 100 pF		UE0043	Post with Base, PI22A02M	Q18	XT0061	Transistor, 2SB1132Q		
C67	CU0043	Chip C, C2012CH1H 220 pF		UE0050	Post with Base, PI22A08M	Q19	XT0061	Transistor, 2SB1132Q		
C68	CU8002	Chip C, C2012B1H 0.01 µF		UE0059	Post with Base, PI22A03M	Q20	XU0012	Digital Transistor, DTC114EK		
C69	CU8001	Chip C, C2012B1H 0.001 µF		UE0071	Post with Base, PI22A05M	Q21	XT0031	Transistor, 2SC2712Y		
C70	CU0006	Chip C, C2012CH1H 5 pF		UE0071	Post with Base, PI22A05M	Q22	XT0031	Transistor, 2SC2712Y		
C71	CU8001	Chip C, C2012B1H 0.001 µF		UE0070	Post with Base, PI22A04M (DR-570E only)	Q23	XT0031	Transistor, 2SC2712Y		
C72	CU8001	Chip C, C2012B1H 0.001 µF		UE0070	Post with Base, PI22A04M (DR-570E only)	Q24	XU0003	Digital Transistor, DTC114TK		
C73	CS0049	Chip Tantal, TMC1C105		UE0041	Mini Pin Jack, TMP-J01X-V6	D1	XD0057	Diode, 1SS184		
C74	CU8001	Chip C, C2012B1H 0.001 µF		UX0131	Line Material, 570HX	D2	XD0103	Diode, 1SS226		
C75	CU8002	Chip C, C2012B1H 0.01 µF		UHF Main Unit				D3	XD0057	Diode, 1SS184
C76	CU8002	Chip C, C2012B1H 0.01 µF	TC1	CT0021	Trimmer C, ECRJA010A12	D4	XD0104	Zener Diode, 02CZ6.2Y		
C77	CU8002	Chip C, C2012B1H 0.01 µF	TC2	CT0028	Trimmer C, ECRJA006A12	D5	XD0112	Vacap, 1SV128		
C78	CU8001	Chip C, C2012B1H 0.001 µF	TC3	CT0028	Trimmer C, ECRJA006A12	D6	XD0112	Vacap, 1SV128		
C79	CU8003	Chip C, C2012B1H 0.1 µF	VR1	RH0031	VR, CVR-42A-103AW1D	D7	XD0057	Diode, 1SS184		
C80	CU8001	Chip C, C2012B1H 0.001 µF	VR2	RH0037	VR, CVR-42A-471AW1D	D8	XD0057	Diode, 1SS184		
C81	CU8002	Chip C, C2012B1H 0.01 µF	VR3	RH0031	VR, CVR-42A-103AW1D	D9	XD0115	Zener Diode, 1SS196		
C82	CU8001	Chip C, C2012B1H 0.001 µF	VR4	RH0038	VR, CVR-42A-473AW1D	D10	XD0057	Diode, 1SS184		
C83	CU8001	Chip C, C2012B1H 0.001 µF	VR5	RH0051	VR, CVR-42A-472AW1D	D11	XD0057	Diode, 1SS184		
C84	CE0188	Chemical C, TWSS 47 µF/16 V	VR6	RH0038	VR, CVR-42A-473AW1D	D12	XD0058	Diode, 1SS181		
C85	CU8001	Chip C, C2012B1H 0.001 µF	VR7	RH0031	VR, CVR-42A-103AW1D	D13	XD0058	Diode, 1SS181		
C86	CU0035	Chip C, C2012CH1H 100 pF		UE0072	Post with Base, PI22A06M	D14	XD0113	Zener Diode, 02CZ4.3Y		
C87	CU0035	Chip C, C2012CH1H 100 pF		UE0071	Post with Base, PI22A05M	D15	XD0057	Diode, 1SS184		
C88	CU0035	Chip C, C2012CH1H 100 pF		UE0043	Post with Base, PI22A02M	D16	XD0057	Diode, 1SS184		
C89	CU0004	Chip C, C2012CH1H 3 pF		UE0071	Post with Base, PI22A05M	L1	QK0050	Air Core Coil, 5×5 Square		
C90	CE0178	Chemical C, TWSS 220 µF/10 V		UE0043	Post with Base, PI22A02M	L2	QK0036	Air Core Coil, 3Ø 1.5T		
C91	CU8001	Chip C, C2012B1H 0.001 µF		UE0071	Post with Base, PI22A05M	L3	QA0061	Coil, 435M×2-10 MHz		
C92	CU8001	Chip C, C2012B1H 0.001 µF		UE0071	Post with Base, PI22A05M	L4	QA0061	Coil, 435M×2-10 MHz		
C93	CE0078	Chemical C, MS9 100 µF/25 V		UE0043	Post with Base, PI22A02M	L5	QC0055	Chip Coil, NL322522T-010M (DR-570E only)		
C94	CU0051	Chip C, C2012CH1H 470 pF		UE0072	Post with Base, PI22A06M	L5	QC0057	Chip Coil, NL322522T-015M (DR-570T only)		
C95	CU8001	Chip C, C2012B1H 0.001 µF		UE0072	Post with Base, PI22A06M	L6	QK0050	Air Core Coil, 5×5 Square		
C96	CU0051	Chip C, C2012CH1H 470 pF		UE0075	Mini Pin Jack, TMP-J01X-A2	L7	QC0071	Chip Coil, NL322522T-R22M		
C97	CU8001	Chip C, C2012B1H 0.001 µF		UE0075	Mini Pin Jack, TMP-J01X-A2	L8	QA0042	Coil		
C98	CU8001	Chip C, C2012B1H 0.001 µF		UE0041	Mini Pin Jack, TMP-J01X-V6	L9	QA0043	Coil		
C99	CU0015	Chip C, C2012CH1H 15 pF		XF1	X'tal Filter, UM-2 30.825 MHz	L10	QC0039	Chip Coil, NL322522T-1R0M		
C100	CE0044	Chemical C, MSS 10 µF/16 V		CF1	Ceramic Filter, CFW455F	L11	QA0041	Coil, 455 kHz		
C101	CU0051	Chip C, C2012CH1H 470 pF		X1	X'tal Filter, HC-49/T 30.37 MHz	L12	QC0059	Chip Coil, NL322522T-022M		
C102	CU8001	Chip C, C2012B1H 0.001 µF		TH1	Thermistor, TD5 150D	L13	QC0061	Chip Coil, NL322522T-033M		
C103	CU8001	Chip C, C2012B1H 0.001 µF			TS0023	L14	QC0055	Chip Coil, NL322522T-010M		
C104	CU0051	Chip C, C2012CH1H 470 pF			TZ0030A	L15	QC0055	Chip Coil, NL322522T-010M		
C105	CU8001	Chip C, C2012B1H 0.001 µF		IC1	IC, MC3361D	L16	QC0055	Chip Coil, NL322522T-010M		
C106	CU0019	Chip C, C2012CH1H 22 pF		IC2	IC, NJM78L08UA-TE1	L17	QC0039	Air Core Coil, 0.8-3Ø-2.5T		
C107	CU8001	Chip C, C2012B1H 0.001 µF		Q1	XE0013	L18	QK0054	Air Core Coil, 0.8-3Ø-1.5T		
C108	CU8001	Chip C, C2012B1H 0.001 µF		Q2	XE0002	C1	CU0035	Chip C, C2012CH1H 100 pF		
C109	CU8001	Chip C, C2012B1H 0.001 µF				C2	CU0004	Chip C, C2012CH1H 3 pF		
C110	CU0029	Chip C, C2012CH1H 56 pF				C3	CU0035	Chip C, C2012CH1H 100 pF		
C111	CU0011	Chip C, C2012CH1H 10 pF				C4	CU8001	Chip C, C2012B1H 0.001 µF		
C112	CU0011	Chip C, C2012CH1H 10 pF				C5	CU8001	Chip C, C2012B1H 0.001 µF		
C113	CU8001	Chip C, C2012B1H 0.001 µF				C6	CU8001	Chip C, C2012B1H 0.001 µF		
C114	CU0023	Chip C, C2012CH1H 33 pF				C7	CU0002	Chip C, C2012CH1H 1 pF		
L1	QC0045	Chip Coil, NL322522T-3R3M				C8	CU0025	Chip C, C2012CH1H 39 pF		
L2	QA0057	Coil, Front End BPF				C9	CU8001	Chip C, C2012B1H 0.001 µF		
L3	QA0057	Coil, Front End BPF				C10	CU8001	Chip C, C2012B1H 0.001 µF		
L4	QA0057	Coil, Front End BPF				C11	CU8001	Chip C, C2012B1H 0.001 µF		
L5	QA0057	Coil, Front End BPF				C12	CU0002	Chip C, C2012CH1H 1 pF (DR-570E only)		
L6	QA0058	Coil				C13	CU0023	Chip C, C2012CH1H 33 pF		
L7	QA0039	Coil				C14	CU8001	Chip C, C2012B1H 0.001 µF		
L8	QA0039	Coil								
L9	QA0041	Coil, 455 kHz								
L10	QC0050	Chip Coil, LQH4N-102K								
L11	QC0034	Chip Coil, NL322522T-R39M								
L12	QC0065	Chip Coil, NL322522T-068M								

Ref. No.	Part Code	Part Name and Number
C15	CU0035	Chip C, C2012CH1H 100 pF
C16	CU8001	Chip C, C2012B1H 0.001 μF
C17	CU0006	Chip C, C2012CH1H 5 pF
C18	CU0011	Chip C, C2012CH1H 10 pF
C19	CU0011	Chip C, C2012CH1H 10 pF
C20	CU8001	Chip C, C2012B1H 0.001 μF
C21	CU0007	Chip C, C2012CH1H 6 pF
C22	CU0035	Chip C, C2012CH1H 10 pF
C23	CU8001	Chip C, C2012B1H 0.001 μF
C24	CU8001	Chip C, C2012B1H 0.001 μF
C25	CU8001	Chip C, C2012B1H 0.001 μF
C26	CU0011	Chip C, C2012CH1H 10 pF
C27	CU8001	Chip C, C2012B1H 0.001 μF
C28	CU0025	Chip C, C2012CH1H 39 pF
C29	CU8006	Chip C, C2012B1E 0.022 μF
C30	CU8003	Chip C, C2012B1H 0.1 μF
C31	CU8003	Chip C, C2012B1H 0.1 μF
C32	CU8003	Chip C, C2012B1H 0.1 μF
C33	CU0051	Chip C, C2012CH1H 470 pF
C34	CE0188	Chemical C, TWSS 47 μF/16 V
C35	CU8002	Chip C, C2012B1H 0.01 μF
C36	CU8002	Chip C, C2012B1H 0.01 μF
C37	CU8003	Chip C, C2012B1H 0.1 μF
C38	CU8002	Chip C, C2012B1H 0.01 μF
C39	CS0060	Chip Tantal, TMC1E474
C41	CU8034	Chip C, C2012B1E 0.033 μF
C42	CU8034	Chip C, C2012B1E 0.033 μF
C43	CU8001	Chip C, C2012B1H 0.001 μF
C44	CS0064	Chip Tantal, TMC1A155
C45	CU8001	Chip C, C2012B1H 0.001 μF
C46	CU8024	Chip C, C2012B1H 0.0047 μF
C47	CU8001	Chip C, C2012B1H 0.001 μF
C48	CU8024	Chip C, C2012B1H 0.0047 μF
C49	CS0065	Chip Tantal, TMC1D684
C50	CS0065	Chip Tantal, TMC1D684
C51	CS0049	Chip Tantal, TMC1C105
C52	CU8001	Chip C, C2012B1H 0.001 μF
C53	CQ0009	Film C, ECQB1H 332 kHz
C70	CU8002	Chip C, C2012B1H 0.01 μF
C72	CE0200	Chemical C, UW 50 V 2.2 μF
C73	CU8002	Chip C, C2012B1H 0.01 μF
C74	CU8001	Chip C, C2012B1H 0.001 μF
C75	CS0049	Chip Tantal, TMC1C105
C76	CU8001	Chip C, C2012B1H 0.001 μF
C77	CU8002	Chip C, C2012B1H 0.01 μF
C78	CU8002	Chip C, C2012B1H 0.01 μF
C79	CE0188	Chemical C, TWSS 47 μF/16 V
C80	CU8001	Chip C, C2012B1H 0.001 μF
C81	CU8001	Chip C, C2012B1H 0.001 μF
C82	CE0178	Chemical C, TWSS 220 μF/10 V
C83	CE0178	Chemical C, TWSS 220 μF/10 V
C84	CS0049	Chip Tantal, TMC1C105
C85	CU8002	Chip C, C2012B1H 0.01 μF
C86	CU8001	Chip C, C2012B1H 0.001 μF
C87	CU8001	Chip C, C2012B1H 0.001 μF
C88	CU0035	Chip C, C2012CH1H 100 pF
C89	CU0035	Chip C, C2012CH1H 100 pF
C90	CU0035	Chip C, C2012CH1H 100 pF
C91	CU8001	Chip C, C2012B1H 0.001 μF
C92	CU0004	Chip C, C2012CH1H 3 pF
C93	CU8001	Chip C, C2012B1H 0.001 μF
C94	CU0006	Chip C, C2012CH1H 5 pF
C97	CU8001	Chip C, C2012B1H 0.001 μF
C98	CU8001	Chip C, C2012B1H 0.001 μF
C99	CU8001	Chip C, C2012B1H 0.001 μF
C100	CU8001	Chip C, C2012B1H 0.001 μF
C102	CU8001	Chip C, C2012B1H 0.001 μF
C103	CE0188	Chemical C, TWSS 47 μF/16 V
C105	CU8001	Chip C, C2012B1H 0.001 μF
C106	CU8001	Chip C, C2012B1H 0.001 μF
C107	CU8001	Chip C, C2012B1H 0.001 μF
C108	CU8001	Chip C, C2012B1H 0.001 μF
C109	CU8001	Chip C, C2012B1H 0.001 μF
C110	CU8001	Chip C, C2012B1H 0.001 μF
C111	CU8001	Chip C, C2012B1H 0.001 μF
C113	CU8001	Chip C, C2012B1H 0.001 μF
C114	CU8001	Chip C, C2012B1H 0.001 μF

Ref. No.	Part Code	Part Name and Number
C115	CU8001	Chip C, C2012B1H 0.001 μF
C116	CU8001	Chip C, C2012B1H 0.001 μF
C118	CU8001	Chip C, C2012B1H 0.001 μF
C119	CE0189	Chemical C, TWSS 100 μF/16 V
C120	CU0023	Chip C, C2012CH1H 33 pF
C121	CE0044	Chemical C, MS5 10 μF/16 V
C122	CU0051	Chip C, C2012CH1H 470 pF
C123	CU0051	Chip C, C2012CH1H 470 pF
C124	CU0051	Chip C, C2012CH1H 470 pF
C125	CU0006	Chip C, C2012CH1H 5 pF
C126	CU0051	Chip C, C2012CH1H 470 pF
C127	CU0051	Chip C, C2012CH1H 470 pF
C128	CE0044	Chemical C, MS5 10 μF/16 V
C129	CU0051	Chip C, C2012CH1H 470 pF
C130	CU0051	Chip C, C2012CH1H 470 pF
C131	CU0017	Chip C, C2012CH1H 18 pF
C132	CU0004	Chip C, C2012CH1H 3 pF
C133	CU0051	Chip C, C2012CH1H 470 pF
C134	CU0015	Chip C, C2012CH1H 15 pF
C135	CU0051	Chip C, C2012CH1H 470 pF
C136	CU0051	Chip C, C2012CH1H 470 pF
C137	CE0044	Chemical C, MS5 10 μF/16 V
C139	CU0051	Chip C, C2012CH1H 470 pF
C140	CE0188	Chemical C, TWSS 47 μF/16 V
R1	RK0018	Chip R, MCR10 100Ω
R2	RK0059	Chip R, MCR10 33 kΩ
R3	RK0069	Chip R, MCR10 100 kΩ
R4	RK0018	Chip R, MCR10 100Ω
R5	RK0011	Chip R, MCR10 47Ω
R6	RK0107	Chip R, MCR10 0Ω
R7	RK0006	Chip R, MCR10 27Ω
R8	RK0107	Chip R, MCR10 0Ω
R9	RK0035	Chip R, MCR10 1 kΩ
R10	RK0056	Chip R, MCR10 22 kΩ
R11	RK0056	Chip R, MCR10 22 kΩ
R12	RK0022	Chip R, MCR10 220Ω
R13	RK0042	Chip R, MCR10 3.3 kΩ
R14	RK0011	Chip R, MCR10 47Ω
R15	RK0039	Chip R, MCR10 2.2 kΩ
R16	RK0042	Chip R, MCR10 3.3 kΩ
R17	RK0107	Chip R, MCR10 0Ω
R18	RK0039	Chip R, MCR10 2.2 kΩ
R19	RK0076	Chip R, MCR10 330 kΩ
R20	RK0035	Chip R, MCR10 1 kΩ
R23	RK0052	Chip R, MCR10 10 kΩ
R24	RK0059	Chip R, MCR10 33 kΩ
R25	RK0042	Chip R, MCR10 3.3 kΩ
R26	RK0048	Chip R, MCR10 6.8 kΩ
R27	RK0076	Chip R, MCR10 330 kΩ
R28	RK0044	Chip R, MCR10 3.9 kΩ
R29	RK0076	Chip R, MCR10 330 kΩ
R30	RK0044	Chip R, MCR10 3.9 kΩ
R31	RK0028	Chip R, MCR10 470Ω
R32	RK0052	Chip R, MCR10 10 kΩ
R33	RK0035	Chip R, MCR10 1 kΩ
R34	RK0039	Chip R, MCR10 2.2 kΩ
R35	RK0037	Chip R, MCR10 1.5 kΩ
R36	RK0052	Chip R, MCR10 10 kΩ
R37	RK0052	Chip R, MCR10 10 kΩ
R38	RK0036	Chip R, MCR10 1.2 kΩ
R39	RK0038	Chip R, MCR10 1.8 kΩ
R40	RK0052	Chip R, MCR10 10 kΩ
R41	RK0052	Chip R, MCR10 10 kΩ
R42	RK0056	Chip R, MCR10 22 kΩ
R43	RK0056	Chip R, MCR10 22 kΩ
R44	RK0038	Chip R, MCR10 1.8 kΩ
R45	RK0052	Chip R, MCR10 10 kΩ
R46	RK0062	Chip R, MCR10 47 kΩ
R47	RK0076	Chip R, MCR10 330 kΩ
R48	RK0052	Chip R, MCR10 10 kΩ
R53	RK0006	Chip R, MCR10 27Ω
R54	RK0039	Chip R, MCR10 2.2 kΩ
R55	RK0006	Chip R, MCR10 27Ω
R56	RK0037	Chip R, MCR10 1.5 kΩ
R57	RK0052	Chip R, MCR10 10 kΩ
R58	RK0052	Chip R, MCR10 10 kΩ

Ref. No.	Part Code	Part Name and Number
R60	RK0052	Chip R, MCR10 10 kΩ
R63	RK0056	Chip R, MCR10 22 kΩ
R64	RK0052	Chip R, MCR10 10 kΩ
R65	RK0018	Chip R, MCR10 100Ω
R66	RK0018	Chip R, MCR10 100Ω
R67	RK0039	Chip R, MCR10 2.2 kΩ
R68	RK0052	Chip R, MCR10 10 kΩ
R69	RK0059	Chip R, MCR10 33 kΩ
R70	RK0062	Chip R, MCR10 47 kΩ
R72	RK0107	Chip R, MCR10 0Ω
R74	RK0107	Chip R, MCR10 0Ω
R76	RK0062	Chip R, MCR10 47 kΩ
R77	RK0025	Chip R, MCR10 330Ω
R80	RK0069	Chip R, MCR10 100 kΩ
R81	RK0035	Chip R, MCR10 1 kΩ
R82	RK0045	Chip R, MCR10 4.7 kΩ
R83	RK0035	Chip R, MCR10 1 kΩ
R84	RK0011	Chip R, MCR10 47Ω
R85	RK0018	Chip R, MCR10 100Ω
R86	RK0011	Chip R, MCR10 47Ω
R87	RK0037	Chip R, MCR10 1.5 kΩ
R88	RK0001	Chip R, MCR10 10Ω
R89	RK0020	Chip R, MCR10 150Ω
R90	RK0010	Chip R, MCR10 39Ω
R91	RK0020	Chip R, MCR10 150Ω
R92	RK0020	Chip R, MCR10 150Ω
R93	RK0037	Chip R, MCR10 1.5 kΩ
R94	RK2010	Chip R, MCR50 33Ω
J5	RK1107	Chip R, MCR18 0Ω
J6	RK1107	Chip R, MCR18 0Ω
J7	RK1107	Chip R, MCR18 0Ω
J8	RK0107	Chip R, MCR10 0Ω
VHF PLL Unit		
IC1	XA0090	IC, M54959FP
Q1	XU0014	Digital Transistor, DTC144EK
Q2	XT0031	Transistor, 2SC2712Y
Q3	XT0080	Transistor, 2SC3324B
Q4	XT0080	Transistor, 2SC3324B
Q5	XT0081	Transistor, 2SC2714Y
CN1	UE0079	Pin Header, SB2P-HVQ-CA
CN2	UE0081	Pin Header, SB6P-HVQ-CA
CN3	UE0088	Pin Header, 6027B-07Z003-T
CN4	UE0085	Pin Header, 6027B-04Z003-T
R1	RK0062	Chip R, MCR10 47 kΩ
R2	RK0062	Chip R, MCR10 47 kΩ
R3	RK0062	Chip R, MCR10 47 kΩ
R4	RK0062	Chip R, MCR10 47 kΩ
R5	RK0062	Chip R, MCR10 47 kΩ
R6	RK0056	Chip R, MCR10 22 kΩ
R7	RK0045	Chip R, MCR10 4.7 kΩ
R8	RK0062	Chip R, MCR10 47 kΩ
R9	RK0045	Chip R, MCR10 4.7 kΩ
R10	RK0052	Chip R, MCR10 10 kΩ
R11	RK0052	Chip R, MCR10 10 kΩ
R12	RK0045	Chip R, MCR10 4.7 kΩ
R13	RK0107	Chip R, MCR10 0Ω
R14	RK0022	Chip R, MCR10 220Ω
R15	RK0056	Chip R, MCR10 22 kΩ
R16	RK0052	Chip R, MCR10 10 kΩ
R17	RK0107	Chip R, MCR10 0Ω
C1	CU8006	Chip C, C2012B1E 0.022 μF
C2	CU8001	Chip C, C2012B1H 0.001 μF
C3	CU8006	Chip C, C2012B1E 0.022 μF
C4	CU8003	Chip C, C2012B1H 0.1 μF
C5	CU0035	Chip C, C2012CH1H 100 pF
C6	CU8006	Chip C, C2012B1E 0.022 μF
C7	CU0051	Chip C, C2012CH1H 470 pF
C8	CS0066	Chip Tantal, TMC1D225
C9	CS0066	Chip Tantal, TMC1D225
C10	CU8001	Chip C, C2012B1H 0.001 μF

Ref. No.	Part Code	Part Name and Number
C11	CS0060	Chip Tantal, TMC1E474
C12	CU8002	Chip C, C2012B1H 0.01 µF
C13	CU8001	Chip C, C2012B1H 0.001 µF
C14	CU0006	Chip C, C2012CH1H 5 pF
C15	CU8001	Chip C, C2012B1H 0.001 µF
L1	QC0045	Chip Coil, NL322522T-3R3M
VHF VCO Unit		
Q1	XE0010	FET, 2SK508K52
Q2	XT0081	Transistor, 2SC2714Y
D1	XD0101	Varicap, 1SV166
D2	XD0101	Varicap, 1SV166
L1	QC0045	Chip Coil, NL322522T-3R3M
L2	QC0045	Chip Coil, NL322522T-3R3M
L3	QC0045	Chip Coil, NL322522T-3R3M
L4	QA0059	Coil
L5	QC0069	Chip Coil, NL322522T-R15K
R1	RK0052	Chip R, MCR10 10 kΩ
R2	RK0018	Chip R, MCR10 100Ω
R3	RK0025	Chip R, MCR10 330Ω
R4	RK0011	Chip R, MCR10 47Ω
R6	RK0018	Chip R, MCR10 100Ω
R7	RK0045	Chip R, MCR10 4.7 kΩ
R8	RK0030	Chip R, MCR10 560Ω
R9	RK0018	Chip R, MCR10 100Ω
J1	RK0107	Chip R, MCR10 0Ω
C1	CU8001	Chip C, C2012B1H 0.001 µF
C2	CU8024	Chip C, C2012B1H 0.0047 µF
C3	CU8001	Chip C, C2012B1H 0.001 µF
C4	CU0001	Chip C, C2012CH1H 0.5 pF
C5	CU8024	Chip C, C2012B1H 0.0047 µF
C6	CU8024	Chip C, C2012B1H 0.0047 µF
C7	CU8001	Chip C, C2012B1H 0.001 µF
C8	CU8001	Chip C, C2012B1H 0.001 µF
C9	CU8001	Chip C, C2012B1H 0.001 µF
C10	CU0003	Chip C, C2012CH1H 2 pF
C11	CU0019	Chip C, C2012CH1H 22 pF
UHF PLL Unit		
IC1	XA0090	IC, M54959FP
Q1	XT0080	Transistor, 2SC3324B
Q2	XT0080	Transistor, 2SC3324B
Q3	XT0080	Transistor, 2SC3324B
Q4	XT0082	Transistor, 2SC3120
CN1	UE0079	Pin Header, SB2P-HVQ-CA
CN2	UE0081	Pin Header, SB6P-HVQ-CA
CN3	UE0088	Pin Header, 6027B-07Z003-T
CN4	UE0085	Pin Header, 6027B-04Z003-T
R1	RK0062	Chip R, MCR10 47 kΩ
R2	RK0062	Chip R, MCR10 47 kΩ
R3	RK0062	Chip R, MCR10 47 kΩ
R4	RK0062	Chip R, MCR10 47 kΩ
R5	RK0062	Chip R, MCR10 47 kΩ
R6	RK0022	Chip R, MCR10 220Ω
R7	RK0040	Chip R, MCR10 2.7 kΩ
R8	RK0050	Chip R, MCR10 8.2 kΩ
R9	RK0052	Chip R, MCR10 10 kΩ
R10	RK0039	Chip R, MCR10 2.2 kΩ
R11	RK0079	Chip R, MCR10 470 kΩ
R12	RK0039	Chip R, MCR10 2.2 kΩ
R13	RK0025	Chip R, MCR10 330Ω
R14	RK0045	Chip R, MCR10 4.7 kΩ
R15	RK0039	Chip R, MCR10 2.2 kΩ
R16	RK0052	Chip R, MCR10 10 kΩ
R17	RK0062	Chip R, MCR10 47 kΩ

Ref. No.	Part Code	Part Name and Number
C1	CU8006	Chip C, C2012B1E 0.022 µF
C2	CU8001	Chip C, C2012B1H 0.001 µF
C3	CU8006	Chip C, C2012B1E 0.022 µF
C4	CU8006	Chip C, C2012B1E 0.022 µF
C5	CU8007	Chip C, C2012Y1H 0.047 µF
C6	CU8006	Chip C, C2012B1E 0.022 µF
C7	CS0057	Chip Tantal, TMC0J225
C8	CS0057	Chip Tantal, TMC0J225
C9	CS0063	Chip Tantal, TMC1V104
C10	CU0051	Chip C, C2012CH1H 470 pF
C11	CU8002	Chip C, C2012B1H 0.01 µF
C12	CU8001	Chip C, C2012B1H 0.001 µF
C13	CU0011	Chip C, C2012CH1H 10 pF
C14	CU0011	Chip C, C2012CH1H 10 pF
L1	QC0055	Chip Coil, NL322522T-010M
UHF VCO Unit		
Q1	XE0010	FET, 2SK508K52
Q2	XT0082	Transistor, 2SC3120
Q3	XT0031	Transistor, 2SC2712Y
D1	XD0100	Varicap, 1SV164
D2	XD0100	Varicap, 1SV164
D3	XD0111	Diode, HSK277
D4	XD0100	Varicap, 1SV164
L1	QC0094	Chip L, MLFLER015TR22M
L2	QC0094	Chip L, MLFLER015TR22M
L3	QK0075	Air Core Coil 0.6-2X5T-RM
L4	QC0094	Chip L, MLFLER015TR22M
L5	QC0034	Chip Coil, LER015TR39M
TC1	CT0028	Trimmer C, ECRJA006A12
TC1	CT0028	Trimmer C, ECRJA006A12
R1	RK0107	Chip R, MCR10 0Ω
R2	RK0062	Chip R, MCR10 47 kΩ
R3	RK0045	Chip R, MCR10 4.7 kΩ
R4	RK0045	Chip R, MCR10 4.7 kΩ
R5	RK0050	Chip R, MCR10 8.2 kΩ
R6	RK0045	Chip R, MCR10 4.7 kΩ
R7	RK0011	Chip R, MCR10 47Ω
R8	RK0011	Chip R, MCR10 47Ω
R9	RK0018	Chip R, MCR10 100Ω
R10	RK0062	Chip R, MCR10 4.7 kΩ
R11	RK0028	Chip R, MCR10 470Ω
C1	CU0051	Chip C, C2012CH1H 470 pF
C2	CU0029	Chip C, C2012CH1H 56 pF
C3	CU8001	Chip C, C2012B1H 0.001 µF
C4	CU0006	Chip C, C2012CH1H 5 pF
C5	CU0006	Chip C, C2012CH1H 5 pF
C6	CU0001	Chip C, C2012CH1H 0.5 pF
C8	CU0010	Chip C, C2012CH1H 9 pF
C9	CU0009	Chip C, C2012CH1H 8 pF
C10	CU8001	Chip C, C2012B1H 0.001 µF
C11	CU0002	Chip C, C2012CH1H 1 pF
C12	CU8001	Chip C, C2012B1H 0.001 µF
C13	CU0051	Chip C, C2012CH1H 470 pF
CPU Unit		
IC1	XA0088	IC, µPD75112GF-517-3BE
IC2	XA0089	IC, NJM78L06UA
Q1	XT0031	Transistor, 2SC2712Y
Q2	XT0031	Transistor, 2SC2712Y
Q3	XU0012	Transistor, DTC114EK
Q4	XT0061	Transistor, 2SB1132Q
D1	XD0057	Diode, 1SS184
D2	XD0057	Diode, 1SS184
D4	XD0057	Diode, 1SS184
D5	XD0057	Diode, 1SS184 (DR-570E only)
D6	XD0057	Diode, 1SS184

Ref. No.	Part Code	Part Name and Number
X1	XB0002	FAR, C4CA0419000K01
R1	RK0051	Chip R, MCR10 9.1 kΩ
R2	RK0069	Chip R, MCR10 100 kΩ
R3	RK0079	Chip R, MCR10 470 kΩ
R4	RK0079	Chip R, MCR10 470 kΩ
R5	RK0064	Chip R, MCR10 56 kΩ
R6	RK0062	Chip R, MCR10 47 kΩ
R7	RK0035	Chip R, MCR10 1 kΩ
R8	RK0035	Chip R, MCR10 1 kΩ
R9	RK0035	Chip R, MCR10 1 kΩ
R10	RK0035	Chip R, MCR10 1 kΩ
R11	RK0062	Chip R, MCR10 47 kΩ
R12	RK0062	Chip R, MCR10 47 kΩ
R13	RK0062	Chip R, MCR10 47 kΩ
R22	RK0062	Chip R, MCR10 47 kΩ
R23	RK0062	Chip R, MCR10 47 kΩ
R24	RK0062	Chip R, MCR10 47 kΩ
R25	RK0062	Chip R, MCR10 47 kΩ
R26	RK0062	Chip R, MCR10 47 kΩ
R27	RK0062	Chip R, MCR10 47 kΩ
R28	RK0062	Chip R, MCR10 47 kΩ
R29	RK0062	Chip R, MCR10 47 kΩ
R30	RK0062	Chip R, MCR10 47 kΩ
R31	RK0062	Chip R, MCR10 47 kΩ
R32	RK0062	Chip R, MCR10 47 kΩ
R33	RK0062	Chip R, MCR10 47 kΩ
R34	RK0062	Chip R, MCR10 47 kΩ
R35	RK0062	Chip R, MCR10 47 kΩ
R36	RK0062	Chip R, MCR10 47 kΩ
R37	RK0062	Chip R, MCR10 47 kΩ
R38	RK0062	Chip R, MCR10 47 kΩ
R39	RK0062	Chip R, MCR10 47 kΩ
R40	RK0062	Chip R, MCR10 47 kΩ
R44	RK0052	Chip R, MCR10 10 kΩ
R45	RK0062	Chip R, MCR10 47 kΩ
R46	RK0107	Chip R, MCR10 0Ω (DR-570T only)
R47	RK0070	Chip R, MCR10 120 kΩ (DR-570E only)
R48	RK0035	Chip R, MCR10 1 kΩ
R49	RK0037	Chip R, MCR10 1.5 kΩ
R50	RK0037	Chip R, MCR10 1.5 kΩ
R51	RD1010	R, 3.3Ω ½ W
R52	RD1011	R, 22Ω ½ W
J1	RD0108	Jumper, JPW01R-01
J2	RD0108	Jumper, JPW01R-01 (DR-570T only)
J3	RD0108	Jumper, JPW01R-01 (DR-570E only)
J4	RD0108	Jumper, JPW01R-01 (DR-570E only)
J5	RD0108	Jumper, JPW01R-01
J10	RK1107	Chip R, MCR18 0Ω
J11	RK1107	Chip R, MCR18 0Ω
J12	RK1107	Chip R, MCR18 0Ω
J13	RK1107	Chip R, MCR18 0Ω
J14	RK1107	Chip R, MCR18 0Ω
J15	RK1107	Chip R, MCR18 0Ω
C1	CU8002	Chip C, C2012B1H 0.01 µF
C2	CU8006	Chip C, C2012B1E 0.022 µF
C3	CE0037	Chemical C, MS5 100 µF/6 V
C4	CE0037	Chemical C, MS5 100 µF/6 V
C5	CU8038	Chip C, CM316Y1E 1 µFZ
C6	CU8001	Chip C, C2012B1H 0.001 µF
C7	CU8001	Chip C, C2012B1H 0.001 µF
C8	CU8001	Chip C, C2012B1H 0.001 µF
C9	CU8003	Chip C, C2012B1H 0.1 µF
C10	CU8001	Chip C, C2012B1H 0.001 µF
C11	CE0037	Chemical C, MS5 100 µF/6 V
C12	CU8003	Chip C, C2012B1H 0.1 µF (DR-570E only)
RE1	UR0002	Rotary Encoder, EVQ-WQGF1524B
RE2	UR0003	Rotary Encoder, EVQ-WT2F2006B
LP1	EP0006	Lamp, BQ031-30659A
LP2	EP0006	Lamp, BQ031-30659A
LP3	EP0006	Lamp, BQ031-30659A
LP4	EP0006	Lamp, BQ031-30659A

Ref. No.	Part Code	Part Name and Number
LP5	EP0006	Lamp, BQ031-30659A
LP6	EP0006	Lamp, BQ031-30659A
LB1	ED0001	Lithium Battery, M2BC200
S1	UU0007	Tact Switch, EVQ-QEC-04K
S2	UU0007	Tact Switch, EVQ-QEC-04K
S3	UU0007	Tact Switch, EVQ-QEC-04K
S4	UU0007	Tact Switch, EVQ-QEC-04K
S5	UU0007	Tact Switch, EVQ-QEC-04K
S6	UU0007	Tact Switch, EVQ-QEC-04K
S7	UU0007	Tact Switch, EVQ-QEC-04K
S8	UU0007	Tact Switch, EVQ-QEC-04K
S9	UU0007	Tact Switch, EVQ-QEC-04K
S10	UU0007	Tact Switch, EVQ-QEC-04K
S11	UU0007	Tact Switch, EVQ-QEC-04K
S12	UU0007	Tact Switch, EVQ-QEC-04K
S13	UU0007	Tact Switch, EVQ-QEC-04K
S14	UU0007	Tact Switch, EVQ-QEC-04K
S15	UQ0011	Push Switch, ESB64801
CN1	UE0035	Mic Connector, FM214-8SMPY
	FP0034	Mic Spacer
VR1	RH0031	VR, CVR-42A-103AW1D (DR-570E only)

Control Unit

IC1	XA0097	IC, NJM4558M
IC2	XA0097	IC, NJM4558M
IC3	XA0095	IC, NJU4066BM
IC4	XA0019	IC, μ PD4094BG
IC5	XA0094	IC, NJM78M08FA
Q1	XU0012	Transistor, DTC114EK (DR-570E only)
Q2	XU0012	Transistor, DTC114EK
Q3	XU0012	Transistor, DTC114EK (DR-570E only)
Q4	XT0031	Transistor, 2SC2712Y
Q5	XT0031	Transistor, 2SC2712Y
Q6	XT0031	Transistor, 2SC2712Y
Q7	XT0031	Transistor, 2SC2712Y
Q8	XT0076	Transistor, 2SC3295B
Q9	XT0076	Transistor, 2SC3295B
Q10	XT0031	Transistor, 2SC2712Y
Q11	XT0031	Transistor, 2SC2712Y
Q12	XT0031	Transistor, 2SC2712Y
Q13	XT0031	Transistor, 2SC2712Y
Q14	XT0031	Transistor, 2SC2712Y
Q15	XT0076	Transistor, 2SC3295B
Q16	XT0076	Transistor, 2SC3295B
Q17	XT0031	Transistor, 2SC2712Y
Q18	XU0012	Transistor, DTC114EK (DR-570E only)
Q19	XT0031	Transistor, 2SC2712Y
Q20	XU0012	Transistor, DTC114EK
Q21	XT0077	Transistor, 2SC3326A
Q22	XT0077	Transistor, 2SC3326A
Q23	XT0031	Transistor, 2SC2712Y
D1	XD0103	Diode, 1SS226
D2	XD0103	Diode, 1SS226
D3	XD0103	Diode, 1SS226
D4	XD0103	Diode, 1SS226
R1	RK0052	Chip R, MCR10 10 k Ω
R2	RK0039	Chip R, MCR10 2.2 k Ω (DR-570E only)
R3	RK0057	Chip R, MCR10 27 k Ω
R4	RK0079	Chip R, MCR10 470 k Ω
R5	RK0039	Chip R, MCR10 2.2 k Ω
R6	RK0081	Chip R, MCR10 560 k Ω
R7	RK0062	Chip R, MCR10 47 k Ω
R8	RK0069	Chip R, MCR10 100 k Ω
R9	RK0062	Chip R, MCR10 47 k Ω
R10	RK0040	Chip R, MCR10 2.7 k Ω
R11	RK0081	Chip R, MCR10 560 k Ω
R12	RK0040	Chip R, MCR10 2.7 k Ω

Ref. No.	Part Code	Part Name and Number
R13	RK0020	Chip R, MCR10 150 Ω
R14	RK0052	Chip R, MCR10 10 k Ω
R15	RK0042	Chip R, MCR10 3.3 k Ω
R16	RK0056	Chip R, MCR10 22 k Ω
R17	RK0048	Chip R, MCR10 6.8 k Ω
R18	RK0079	Chip R, MCR10 470 k Ω
R19	RK0069	Chip R, MCR10 100 k Ω
R20	RK0045	Chip R, MCR10 4.7 k Ω
R21	RK0035	Chip R, MCR10 1 k Ω
R22	RK0056	Chip R, MCR10 22 k Ω
R23	RK0061	Chip R, MCR10 39 k Ω
R24	RK0010	Chip R, MCR10 39 Ω
R25	RK0040	Chip R, MCR10 2.7 k Ω
R28	RK0039	Chip R, MCR10 2.2 k Ω (DR-570T only)
R29	RK0035	Chip R, MCR10 1 k Ω
R30	RK0039	Chip R, MCR10 2.2 k Ω
R31	RK0042	Chip R, MCR10 3.3 k Ω (DR-570E only)
R31	RK0037	Chip R, MCR10 1.5 k Ω (DR-570T only)
R32	RK0052	Chip R, MCR10 10 k Ω
R33	RK0076	Chip R, MCR10 330 k Ω (DR-570E only)
R33	RK0071	Chip R, MCR10 150 k Ω (DR-570T only)
R34	RK0030	Chip R, MCR10 560 Ω
R35	RK0047	Chip R, MCR10 5.6 k Ω
R36	RK0054	Chip R, MCR10 15 k Ω
R37	RK0086	Chip R, MCR10 1 M Ω
R38	RK0047	Chip R, MCR10 5.6 k Ω
R39	RK0018	Chip R, MCR10 100 Ω
R40	RK0072	Chip R, MCR10 180 k Ω
R41	RK0073	Chip R, MCR10 220 k Ω
R42	RK0062	Chip R, MCR10 47 k Ω
R43	RK0059	Chip R, MCR10 33 k Ω
R44	RK0062	Chip R, MCR10 47 k Ω
R45	RK0073	Chip R, MCR10 220 k Ω
R46	RK0076	Chip R, MCR10 330 k Ω
R47	RK0067	Chip R, MCR10 82 k Ω
R48	RK0067	Chip R, MCR10 82 k Ω
R49	RK0067	Chip R, MCR10 82 k Ω
R50	RK0052	Chip R, MCR10 10 k Ω
R51	RK0052	Chip R, MCR10 10 k Ω
R52	RK0039	Chip R, MCR10 2.2 k Ω
R53	RK0079	Chip R, MCR10 470 k Ω
R54	RK0022	Chip R, MCR10 220 Ω
R55	RK0069	Chip R, MCR10 100 k Ω
R56	RK0069	Chip R, MCR10 100 k Ω
R57	RK0033	Chip R, MCR10 820 Ω
R58	RK0052	Chip R, MCR10 10 k Ω
R59	RK0039	Chip R, MCR10 2.2 k Ω
R60	RK0052	Chip R, MCR10 10 k Ω
R61	RK0057	Chip R, MCR10 27 k Ω
R62	RK0079	Chip R, MCR10 470 k Ω
R63	RK0039	Chip R, MCR10 2.2 k Ω
R64	RK0028	Chip R, MCR10 470 Ω
R65	RK0081	Chip R, MCR10 560 k Ω
R66	RK0040	Chip R, MCR10 2.7 k Ω
R67	RK0081	Chip R, MCR10 560 k Ω
R68	RK0040	Chip R, MCR10 2.7 k Ω
R69	RK0020	Chip R, MCR10 150 Ω
R70	RK0018	Chip R, MCR10 100 Ω
R71	RK0042	Chip R, MCR10 3.3 k Ω
R72	RK0056	Chip R, MCR10 22 k Ω
R73	RK0052	Chip R, MCR10 10 k Ω
R74	RK0048	Chip R, MCR10 6.8 k Ω
R75	RK0069	Chip R, MCR10 100 k Ω
R76	RK0079	Chip R, MCR10 470 k Ω
R77	RK0045	Chip R, MCR10 4.7 k Ω
R78	RK0035	Chip R, MCR10 1 k Ω
R79	RK0056	Chip R, MCR10 22 k Ω
R80	RK0061	Chip R, MCR10 39 k Ω
R81	RK0040	Chip R, MCR10 2.7 k Ω
R82	RK0010	Chip R, MCR10 39 Ω
R84	RK0069	Chip R, MCR10 100 k Ω
R85	RK0035	Chip R, MCR10 1 k Ω
R86	RK0042	Chip R, MCR10 3.3 k Ω
R87	RK0042	Chip R, MCR10 3.3 k Ω
R88	RK0069	Chip R, MCR10 100 k Ω
R89	RK0045	Chip R, MCR10 4.7 k Ω
R90	RK0045	Chip R, MCR10 4.7 k Ω

Ref. No.	Part Code	Part Name and Number
R91	RK0056	Chip R, MCR10 22 k Ω
R92	RK0056	Chip R, MCR10 22 k Ω
R93	RK0035	Chip R, MCR10 1 k Ω
J1	RK0107	Chip R, MCR10 0 Ω
J2	RK0107	Chip R, MCR10 0 Ω
J3	RK0107	Chip R, MCR10 0 Ω
J4	RK0107	Chip R, MCR10 0 Ω
J5	RK0107	Chip R, MCR10 0 Ω
J6	RK0107	Chip R, MCR10 0 Ω
J7	RK0107	Chip R, MCR10 0 Ω
J8	RK0107	Chip R, MCR10 0 Ω
J10	RK1107	Chip R, MCR18 0 Ω
J11	RK1107	Chip R, MCR18 0 Ω
J12	RK1107	Chip R, MCR18 0 Ω
J13	RK1107	Chip R, MCR18 0 Ω
J14	RK0107	Chip R, MCR10 0 Ω
J15	RK0107	Chip R, MCR10 0 Ω
J16	RK0107	Chip R, MCR10 0 Ω
J17	RK0107	Chip R, MCR10 0 Ω (DR-570E only)
J19	RK1107	Chip R, MCR18 0 Ω
J20	RK1107	Chip R, MCR18 0 Ω
J21	RK1107	Chip R, MCR18 0 Ω
J22	RK1107	Chip R, MCR18 0 Ω
J23	RK1107	Chip R, MCR18 0 Ω
J24	RK1107	Chip R, MCR18 0 Ω
J25	RK1107	Chip R, MCR18 0 Ω (DR-570E only)
J26	RK1107	Chip R, MCR18 0 Ω
C1	CU8003	Chip C, C2012B1H 0.1 μ F
C2	CU0035	Chip C, C2012CH1H 100 pF
C3	CU8002	Chip C, C2012B1H 0.01 μ F
C4	CU8023	Chip C, C2012B1H 0.0039 μ FK
C5	CS0049	Chip Tantal, TMC1C105
C6	CS0052	Chip Tantal, TMC1A336
C7	CU8003	Chip C, C2012B1H 0.1 μ F
C8	CU8001	Chip C, C2012B1H 0.001 μ F
C9	CU8003	Chip C, C2012B1H 0.1 μ F
C10	CU8001	Chip C, C2012B1H 0.001 μ F
C11	CU8035	Chip C, C2012B1E 0.039 μ FK
C12	CS0052	Chip Tantal, TMC1A336
C13	CE0097	Chemical C, MS5 68 μ F/10 V
C14	CU8001	Chip C, C2012B1H 0.001 μ F
C15	CU8001	Chip C, C2012B1H 0.001 μ F
C16	CU8002	Chip C, C2012B1H 0.01 μ F
C17	RK1107	Chip R, MCR18 0 Ω (DR-570E only)
C17	CU8038	Chip C, CM316Y1E 1 μ FZ (DR-570T only)
C18	CU0035	Chip C, C2012CH1H 100 pF
C19	CU0035	Chip C, C2012CH1H 100 pF
C20	CU8034	Chip C, C2012B1E 0.033 μ FK
C21	CU8034	Chip C, C2012B1E 0.033 μ FK
C22	CU8038	Chip C, CM316Y1E 1 μ FZ
C23	CU8024	Chip C, C2012B1H 0.0047 μ FK
C24	CU0053	Chip C, C2012CH1H 560 pF
C25	CU8032	Chip C, C2012B1H 0.01 μ F
C26	CS0049	Chip Tantal, TMC1C105
C27	CU8038	Chip C, CM316Y1E 1 μ FZ
C28	CU0057	Chip C, C2012CH1H 820 pF
C29	CU8008	Chip C, C2012B1H 0.0027 μ FK
C30	CU0035	Chip C, C2012CH1H 100 pF
C31	CU0035	Chip C, C2012CH1H 100 pF
C32	CU8024	Chip C, C2012B1H 0.0047 μ FK
C33	CS0057	Chip Tantal, TMC0J225
C34	CU8003	Chip C, C2012B1H 0.1 μ F
C35	CU0023	Chip C, C2012CH1H 33 pF
C36	CU8002	Chip C, C2012B1H 0.01 μ F
C37	CU8024	Chip C, C2012B1H 0.0047 μ FK
C38	CS0057	Chip Tantal, TMC0J225
C39	CU8002	Chip C, C2012B1H 0.01 μ F
C40	CU8003	Chip C, C2012B1H 0.1 μ F
C41	CS0049	Chip Tantal, TMC1C105
C42	CS0065	Chip Tantal, TMC1D684
C43	CS0052	Chip Tantal, TMC1A336
C44	CU8034	Chip C, C2012B1E 0.033 μ FK
C45	CU8030	Chip C, C2012B1H 0.015 μ FK
C46	CU8034	Chip C, C2012B1E 0.033 μ FK

Ref. No.	Part Code	Part Name and Number
C47	CU8035	Chip C, C2012B1E 0.039 μFK
C48	CU8038	Chip C, CM316Y1E 1 μFZ
C49	CE0097	Chemical C, MS5 68 μF/10 V
C50	CU8002	Chip C, C2012B1H 0.01 μF
C51	CU0053	Chip C, C2012CH1H 560 pF
C52	CU8024	Chip C, C2012B1H 0.0047 μFK
C53	CU8024	Chip C, C2012B1H 0.0047 μFK
C54	CU0023	Chip C, C2012CH1H 33 pF
C55	CU8002	Chip C, C2012B1H 0.01 μF
C56	CU8024	Chip C, C2012B1H 0.0047 μFK
C57	CS0051	Chip Tantal, TMC1C106
C58	CS0057	Chip Tantal, TMC0J225
C59	CU8002	Chip C, C2012B1H 0.01 μF
C60	CU8003	Chip C, C2012B1H 0.1 μF
C61	CS0049	Chip Tantal, TMC1C105
C62	CS0065	Chip Tantal, TMC1D684
C63	CS0052	Chip Tantal, TMC1A336
C64	CU8030	Chip C, C2012B1H 0.015 μFK
C65	CU8034	Chip C, C2012B1E 0.033 μFK
C66	CU8034	Chip C, C2012B1E 0.033 μFK
C67	CS0057	Chip Tantal, TMC0J225
C68	CS0057	Chip Tantal, TMC0J225
C69	CU0035	Chip C, C2012CH1H 100 pF
C70	CU8001	Chip C, C2012B1H 0.001 μF
C71	CU8001	Chip C, C2012B1H 0.001 μF
L1	QC0049	Chip Coil, NL322522T-221K
L2	QC0050	Chip Coil, LQH4N102K
L3	QC0049	Chip Coil, NL322522T-221K
L4	QC0050	Chip Coil, LQH4N102K
Duplexer Unit		
D1	XD0058	Diode, 1SS181
C1	CC5022	Ceramic C, HM60SJSLS270J
C2	CC5022	Ceramic C, HM60SJSLS270J
C4	CU0051	Chip C, C2012CH1H 470 pF
C6	CC5015	Ceramic C, HM60SJSLS060D
C7	CC5014	Ceramic C, HM60SJSLS040C
C8	CC5015	Ceramic C, HM60SJSLS060D
C9	CC5002	Ceramic C, 10 pF 500 V SL
L1	QK0055	Air Core Coil, 3 ∅ 6 T
L2	QK0055	Air Core Coil, 3 ∅ 6 T
L3	QK0054	Air Core Coil, 3 ∅ 1.5 T
L4	QC0039	Chip Coil, NL 322522T-1ROM
L5	QK0054	Air Core Coil, 3 ∅ 1.5 T
L6	QK0054	Air Core Coil, 3 ∅ 1.5 T
RL1	UL0008	Relay, AG201744
Crystal Converter Unit		
IC1	XA0098	IC, NJM78L05UA
Q1	XT0072	Transistor, 2SC3011
Q2	XT0030	Transistor, 2SC3356
Q3	XT0039	Transistor, 2SC2668Y
Q4	XT0019	Transistor, 2SC2407
Q5	XT0035	Transistor, 2SC3429
Q6	XT0039	Transistor, 2SC2668Y
Q7	XU0022	Digital Transistor, DTA114EK
Q8	XU0022	Digital Transistor, DTA114EK
D1	XD0070	Diode, 1SS265
D2	XD0070	Diode, 1SS265
D3	XD0070	Diode, 1SS265
D4	XD0070	Diode, 1SS265
D5	XD0040	Diode, DAN202K
D6	XD0058	Diode, 1SS181
X1	XQ0024	X'tal, UM-1 40.5 MHz
X2	XQ0025	X'tal, UM-1 40.0 MHz
CN⊗	UE0055	Post with Base, PI22B02M
CN⊙	UE0055	Post with Base, PI22B02M

Ref. No.	Part Code	Part Name and Number
	TZ0021	Insulating Paper
R1	RK0064	Chip R, MCR10 56 kΩ
R2	RK0052	Chip R, MCR10 10 kΩ
R3	RK0040	Chip R, MCR10 2.7 kΩ
R4	RK0059	Chip R, MCR10 33 kΩ
R5	RK0052	Chip R, MCR10 10 kΩ
R6	RK0028	Chip R, MCR10 470Ω
R7	RK0022	Chip R, MCR10 220Ω
R8	RK0031	Chip R, MCR10 680Ω
R9	RK0039	Chip R, MCR10 2.2 kΩ
R10	RK0054	Chip R, MCR10 15 kΩ
R11	RK0054	Chip R, MCR10 15 kΩ
R12	RK0033	Chip R, MCR10 820Ω
R13	RK0031	Chip R, MCR10 680Ω
R14	RK0045	Chip R, MCR10 4.7 kΩ
R15	RK0054	Chip R, MCR10 15 kΩ
R16	RK0025	Chip R, MCR10 330Ω
R17	RK0069	Chip R, MCR10 100 kΩ
R18	RK0025	Chip R, MCR10 330Ω
R19	RK0052	Chip R, MCR10 10 kΩ
R20	RK0039	Chip R, MCR10 2.2 kΩ
R21	RK0054	Chip R, MCR10 15 kΩ
R22	RK0033	Chip R, MCR10 820Ω
R23	RK0018	Chip R, MCR10 100Ω
R24	RK0054	Chip R, MCR10 15 kΩ
R25	RK0039	Chip R, MCR10 2.2 kΩ
C1	CU0006	Chip C, C2012CH1H 5 pF
C2	CU0003	Chip C, C2012CH1H 2 pF
C3	CU0003	Chip C, C2012CH1H 2 pF
C4	CU0006	Chip C, C2012CH1H 5 pF
C5	CU0001	Chip C, C2012CH1H 0.5 pF
C6	CU0051	Chip C, C2012CH1H 470 pF
C7	CU0051	Chip C, C2012CH1H 470 pF
C8	CU0006	Chip C, C2012CH1H 5 pF
C9	CU8001	Chip C, C2012B1H 0.001 μF
C10	CU0019	Chip C, C2012CH1H 22 pF
C11	CU0006	Chip C, C2012CH1H 5 pF
C12	CU0002	Chip C, C2012CH1H 1 pF
C13	CU8001	Chip C, C2012B1H 0.001 μF
C14	CU8001	Chip C, C2012B1H 0.001 μF
C15	CU8001	Chip C, C2012B1H 0.001 μF
C16	CU0015	Chip C, C2012CH1H 15 pF
C17	CU0015	Chip C, C2012CH1H 15 pF
C18	CU0027	Chip C, C2012CH1H 47 pF
C19	CU0005	Chip C, C2012CH1H 4 pF
C20	CU0003	Chip C, C2012CH1H 2 pF
C21	CU0004	Chip C, C2012CH1H 3 pF
C22	CU8001	Chip C, C2012B1H 0.001 μF
C23	CU0013	Chip C, C2012CH1H 12 pF
C24	CU8001	Chip C, C2012B1H 0.001 μF
C25	CU8001	Chip C, C2012B1H 0.001 μF
C26	CU8001	Chip C, C2012B1H 0.001 μF
C27	CU8001	Chip C, C2012B1H 0.001 μF
C28	CU0027	Chip C, C2012CH1H 47 pF
C29	CU8001	Chip C, C2012B1H 0.001 μF
C30	CU0005	Chip C, C2012CH1H 4 pF
C31	CU8001	Chip C, C2012B1H 0.001 μF
C32	CU0011	Chip C, C2012CH1H 10 pF
C33	CU0006	Chip C, C2012CH1H 5 pF
C34	CU0008	Chip C, C2012CH1H 7 pF
C35	CU8001	Chip C, C2012B1H 0.001 μF
C36	CU8001	Chip C, C2012B1H 0.001 μF
C37	CU0015	Chip C, C2012CH1H 15 pF
C38	CU8001	Chip C, C2012B1H 0.001 μF
C39	CU0015	Chip C, C2012CH1H 15 pF
C40	CU0027	Chip C, C2012CH1H 47 pF
C41	CU0015	Chip C, C2012CH1H 15 pF
C42	CU0027	Chip C, C2012CH1H 47 pF
C43	CU0005	Chip C, C2012CH1H 4 pF
C44	CU8001	Chip C, C2012B1H 0.001 μF
C45	CU0002	Chip C, C2012CH1H 1 pF
C46	CU0001	Chip C, C2012CH1H 0.5 pF
C47	CU0003	Chip C, C2012CH1H 2 pF
C48	CU0005	Chip C, C2012CH1H 4 pF
C49	CU0006	Chip C, C2012CH1H 5 pF

Ref. No.	Part Code	Part Name and Number
C50	CU8001	Chip C, C2012B1H 0.001 μF
C51	CU8001	Chip C, C2012B1H 0.001 μF
C52	CU8001	Chip C, C2012B1H 0.001 μF
C53	CU0027	Chip C, C2012CH1H 47 pF
C54	CU0051	Chip C, C2012CH1H 470 pF
C55	CE0198	Chemical C, MS5 100 μF/10 V
C56	CE0198	Chemical C, MS5 100 μF/10 V
C57	CU8001	Chip C, C2012B1H 0.001 μF
L1	QK0036	Air Core Coil, 3 ∅ 1.5 T
L2	QK0036	Air Core Coil, 3 ∅ 1.5 T
L3	QK0037	Air Core Coil, 3 ∅ 2.5 T
L4	QK0037	Air Core Coil, 3 ∅ 2.5 T
L5	QA0030	HF Coil
L6	QA0031	HF Coil
L7	QA0032	HF Coil
L8-A	RD0108	JBW01R-01
L8-B	RD0108	JBW01R-01
L9	QA0030	HF Coil
L10	QA0033	HF Coil
L11	QA0034	HF Coil
L12	QA0036	HF Coil
L13	QA0035	HF Coil
L14	QC0071	Chip Coil, NL322522T-R22K
L15	QC0045	Chip Coil, NL322522T-3R3M
TC1	CT0013	Trimmer C, ECR-GA003A30
TC2	CT0013	Trimmer C, ECR-GA003A30
TC3	CT0013	Trimmer C, ECR-GA003A30
TC4	CT0013	Trimmer C, ECR-GA003A30
TC5	CT0001	Trimmer C, ECR-GA010D30
TC6	CT0001	Trimmer C, ECR-GA010D30
Power Source Unit		
C75	CU8001	Chip C, C2012B1H 0.001 μF
C76	CU8001	Chip C, C2012B1H 0.001 μF
C77	CU8001	Chip C, C2012B1H 0.001 μF
C78	CE0193	Chemical C, TWSS 1000 μF/16 V
L21	QL0007	Coil, AF Choke
D12	XD0107	Diode, G3B
CN⊗	UE0069	Post with Base, PI22A03M
VHF Final Unit		
IC1	XA0043	Module, M57726
Q2	XT0020	Transistor, 2SC2538
Q3	XT0041	Transistor, FMW1
O6	XU0012	Digital Transistor, DTC 114EK
D1	XD0057	Diode, 1SS184
D2	XD0106	Diode, UM9401
D3	XD0014	Diode, M308
D4	XD0102	Diode, 1SS101
D5	XD0057	Diode, 1SS184
R1	RK0023	Chip R, MCR10 270Ω
R2	RK0004	Chip R, MCR10 18Ω
R3	RK0023	Chip R, MCR10 270Ω
R4	RK0011	Chip R, MCR10 47Ω
R5	RK0037	Chip R, MCR10 1.5 kΩ
R6	RD1011	R, 1/2 W 22Ω
R10	RK0107	Chip R, MCR10 0Ω
R11	RD1008	R, 1/2 W 150Ω
R13	RK0056	Chip R, MCR10 22 kΩ
R14	RK0056	Chip R, MCR10 22 kΩ
R15	RK0107	Chip R, MCR10 0Ω
R16	RK0056	Chip R, MCR10 22 kΩ
R17	RK0059	Chip R, MCR10 33 kΩ
R19	RK0008	Chip R, MCR10 33Ω
R20	RK0107	Chip R, MCR10 0Ω
R26	RK0076	Chip R, MCR10 330 kΩ

Ref. No.	Part Code	Part Name and Number	Ref. No.	Part Code	Part Name and Number	Ref. No.	Part Code	Part Name and Number
C1	CU8001	Chip C, C2012B1H 0.001 µF	D7	XD0106	Diode, UM9401	CTCSS (EJ-5U) Unit (T Only)		
C2	CU0030	Chip C, C2012CH1H 62 pF	D8	XD0014	Diode, Mi308			
C3	CU0034	Chip C, C2012CH1H 91 pF	D9	XD0102	Diode, 1SS101	CN1	UE0097	Pin Header SB3P-HVQ-CA
C4	CU8001	Chip C, C2012B1H 0.001 µF	D10	XD0102	Diode, 1SS101	CN2	UE0077	Pin Header SB7P-HVQ-CA
C5	CU8001	Chip C, C2012B1H 0.001 µF	R23	RK0107	Chip R, MCR10 0Ω	CN3	UE0045	Post with Base PI22A11M
C6	CU0018	Chip C, C2012CH1H 20 pF	R24	RK0107	Chip R, MCR10 0Ω	IC1	XA0020	IC MN6520
C7	CE0044	Chemical C, MS5 10 µF/16 V	R25	RD1008	R, ½ W 150Ω	IC2	XA0020	IC MN6520
C8	CU8001	Chip C, C2012B1H 0.001 µF	R26	RK0052	Chip R, MCR10 10 kΩ	IC3	XA0019	IC UPD4094BG-T1
C9	CU8001	Chip C, C2012B1H 0.001 µF	R27	RK0006	Chip R, MCR10 27Ω	IC4	XA0019	IC UPD4094BG-T1
C10	CU8001	Chip C, C2012B1H 0.001 µF	L13	QK0054	Air Core Coil, 3 Ø 1.5 T	X1	XB0002	FAR-C4CA-04194000K01
C11	CU8001	Chip C, C2012B1H 0.001 µF	L14	QK0061	Air Core Coil, 0.5-3 Ø-9.5 T-L	Q1	XT0031	Transistor, 2SC2712Y
C12	CU8001	Chip C, C2012B1H 0.001 µF	L15	QK0068	Air Core Coil, 0.8-3 Ø-2.5 T-RS	Q2	XT0031	Transistor, 2SC2712Y
C13	CE0044	Chemical C, MS5 10 µF/16 V	L16	QK0063	Air Core Coil, 0.5-3 Ø-3.5 T-R	Q3	XU0012	Digital Transistor DTC114EK
C14	CE0044	Chemical C, MS5 10 µF/16 V	L17	QK0054	Air Core Coil, 3 Ø 1.5 T	VR1	RH0058	CVR-42A203AW1D
C16	CC5002	Ceramic C, 10 pF 500 V SL	L18	QK0065	Air Core Coil, 0.8-4 Ø-1.25 T-R	R1	RK0086	Chip R, MCR10 1 MΩ
C17	CU8001	Chip C, C2012B1H 0.001 µF	L19	QC0013	Choke Coil, LAL021ROM	R2	RK0039	Chip R, MCR10 2.2 kΩ
C18	CU8001	Chip C, C2012B1H 0.001 µF	C43	CU8001	Chip C, C2012B1H 0.001 µF	R3	RK0044	Chip R, MCR10 3.9 kΩ
C19	CC5016	Ceramic C, HM60SJSJL080J	C44	CU0051	Chip C, C2012CH1H 470 pF	R4	RK0044	Chip R, MCR10 3.9 kΩ
C20	CC5025	Ceramic C, HM60SJSYB102K	C45	CE0044	Chemical C, MS5 10 µF/16 V	R5	RK0039	Chip R, MCR10 2.2 kΩ
C21	CC5019	Ceramic C, HM60SJSJL150J	C46	CU0051	Chip C, C2012CH1H 470 pF	R6	RK0086	Chip R, MCR10 1 MΩ
C22	CU0017	Chip C, C2012CH1H 18 pF	C47	CU0051	Chip C, C2012CH1H 470 pF	R8	RK0045	Chip R, MCR10 4.7 kΩ
C23	CC5021	Ceramic C, HM60SJSJL220J	C48	CE0044	Chemical C, MS5 10 µF/16 V	R10	RK0071	Chip R, MCR10 150 kΩ
C24	CC5021	Ceramic C, HM60SJSJL220J	C49	CU7013	Chip Mica, UC232H0050C	R11	RK0039	Chip R, MCR10 2.2 kΩ
C25	CU0001	Chip C, C2012CH1H 0.5 pF	C50	CC5013	Ceramic C, HM60SJSJL020C	R12	RK0053	Chip R, MCR10 12 kΩ
C26	CC5022	Ceramic C, HM60SJSJL270J	C51	CU0005	Chip C, C2012CH1H 4 pF	R13	RK0055	Chip R, MCR10 18 kΩ
C27	CU0002	Chip C, C2012CH1H 1 pF	C52	CU0001	Chip C, C2012CH1H 0.5 pF	R14	RK0052	Chip R, MCR10 10 kΩ
C28	CU8001	Chip C, C2012B1H 0.001 µF	C53	CC5007	Ceramic C, HM60SJSJL050C	R15	RK0052	Chip R, MCR10 10 kΩ
C29	CC5020	Ceramic C, HM60SJSJL180J	C54	CU0001	Chip C, C2012CH1H 0.5 pF	R18	RK0071	Chip R, MCR10 150 kΩ
C30	CU8001	Chip C, C2012B1H 0.001 µF	C55	CU7021	Chip Mica, UC232H0160J	R19	RK0039	Chip R, MCR10 2.2 kΩ
C31	CU8001	Chip C, C2012B1H 0.001 µF	C56	CU0013	Chip C, C2012CH1H 12 pF	R20	RK0053	Chip R, MCR10 12 kΩ
C33	CU8001	Chip C, C2012B1H 0.001 µF	C57	CU7019	Chip Mica, UC232H0220F	R21	RK0055	Chip R, MCR10 18 kΩ
C34	CU8001	Chip C, C2012B1H 0.001 µF	C58	CC5007	Ceramic C, HM60SJSJL050C	R22	RK0052	Chip R, MCR10 10 kΩ
C35	CU8024	Chip C, C2012B1H 0.0047 µF	C59	CU7021	Chip Mica, UC232H0160J	R23	RK0052	Chip R, MCR10 10 kΩ
C36	CU8001	Chip C, C2012B1H 0.001 µF	C60	CC5007	Ceramic C, HM60SJSJL050C	R24	RK0067	Chip R, MCR10 82 kΩ
C37	CU8024	Chip C, C2012B1H 0.0047 µF	C62	CC5014	Ceramic C, HM60SJSJL040C	R25	RK0067	Chip R, MCR10 82 kΩ
C38	CU8001	Chip C, C2012B1H 0.001 µF	C63	CU0051	Chip C, C2012CH1H 470 pF	C1	CU8003	Chip C, C2012JF1E104Z
C39	CU8001	Chip C, C2012B1H 0.001 µF	C64	CU0051	Chip C, C2012CH1H 470 pF	C2	CU8007	Chip C, C2012JF1H473Z
C40	CU8001	Chip C, C2012B1H 0.001 µF	C66	CU0051	Chip C, C2012CH1H 470 pF	C3	CU8003	Chip C, C2012JF1E104Z
C41	CU8001	Chip C, C2012B1H 0.001 µF	C68	CU0051	Chip C, C2012CH1H 470 pF	C4	CU8007	Chip C, C2012JF1H473Z
C42	CU8001	Chip C, C2012B1H 0.001 µF	C69	CU8001	Chip C, C2012B1H 0.001 µF	C5	CE0116	Chemical C, MS7 6.3 V/47 µF
L1	QC0059	Chip L, NL322522T-022M	C70	CU8001	Chip C, C2012B1H 0.001 µF	C6	CU0005	Chip C, C2012CH1H 4 pF
L2	QC0055	Chip L, NL322522T-010M	C71	CU0051	Chip C, C2012CH1H 470 pF	C7	CU8003	Chip C, C2012JF1E104Z
L3	QK0031	Air Core Coil, 3 Ø-6 T	C72	CU0051	Chip C, C2012CH1H 470 pF	C8	CS0059	Chip Tantal, TMC0J226TR
L4	QK0062	Air Core Coil, 0.6-3 Ø-3 T-LS	C73	CU0051	Chip C, C2012CH1H 470 pF	C9	CU8003	Chip C, C2012JF1E104Z
L5	QK0064	Air Core Coil, 0.8-4 Ø-1.5 T-L (DR-570E only)	C74	CU0051	Chip C, C2012CH1H 470 pF	C10	CS0059	Chip Tantal, TMC0J226TR
L5	QK0054	Air Core Coil, 0.8-3 Ø-1.5-R (DR-570 T only)		UE0080	Penetrating Paper	C11	CS0055	Chip Tantal, TMC0G106TR
L6	QK0044	Air Core Coil, 3 Ø-9.5 T				C12	CS0055	Chip Tantal, TMC0G106TR
L7	QK0067	Air Core Coil, 0.6-3 Ø-7 T-R				C13	CU8002	Chip C, C2012B1H103K
L8	QK0058	Air Core Coil, 0.8-3 Ø-6 T-RS						
L9	QK0044	Air Core Coil, 3 Ø-9.5 T (DR-570 E only)						
L9	QK0067	Air Core Coil, 0.6-3 Ø-7 T-R (DR-570T only)						
L10	QK0060	Air Core Coil, 0.8-3 Ø-5 T-RS						
L11	QK0077	Air Core Coil, 0.8-3 Ø-3 T-RS (DR-570 E only)						
L11	QK0054	Air Core Coil, 0.8-3 Ø-1.5-R (DR-570 T only)						
L12	QC0013	Choke Coil, LAL02-1ROM						
VR1	RH0038	VR, CVR-42A-473AW1D						
VR2	RH0051	VR, CVR-42A-472AW1D						
VR3	RH0038	VR, CVR-42A-473AW1D						
VR4	RH0056	VR, CVR-42A-333AW1D						
JK1	UJ0013	Earphone Jack, JSJ140301010						
TH1	XS0006	Thermistor, TD5-C350DA						
UHF Final Unit								
IC4	XA0077	Module, M57788M						
Q5	XT0064	Transistor, 2SD1761E						

■ DISASSEMBLING PROCEDURE

Removing Upper Case

- (1) Remove 7 screws (A).
- (2) Unplug connector (CN SP).

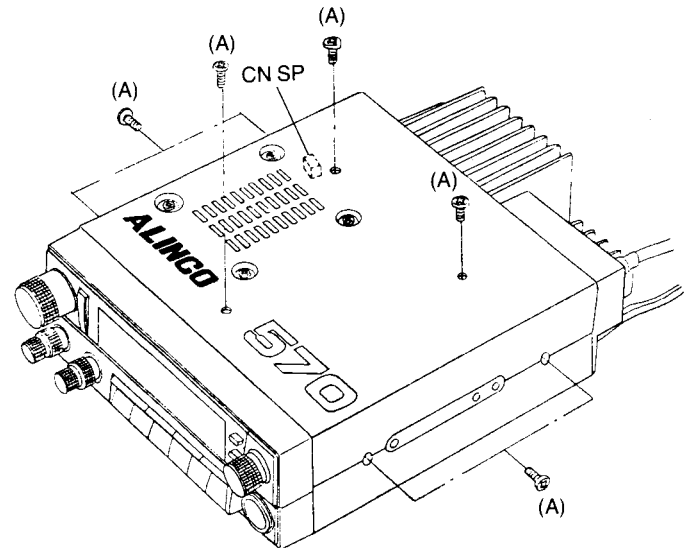

Removing VHF (144 M) Main PCB

- (1) Remove 7 screws (B).
- (2) Unplug 7 connectors (CN C, CN G, CN H, CN I, CN J, CN K, CN L), and remove PCB (EJ4UZ).
- (3) Remove 4 screws (C) on shield plate.

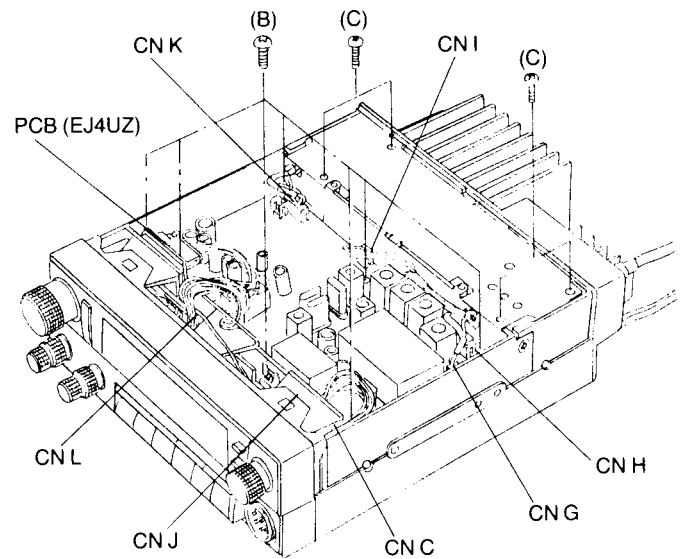

Removing Lower Case

- (1) Turn over Unit, and remove 3 screws (D) beneath Lower Case.

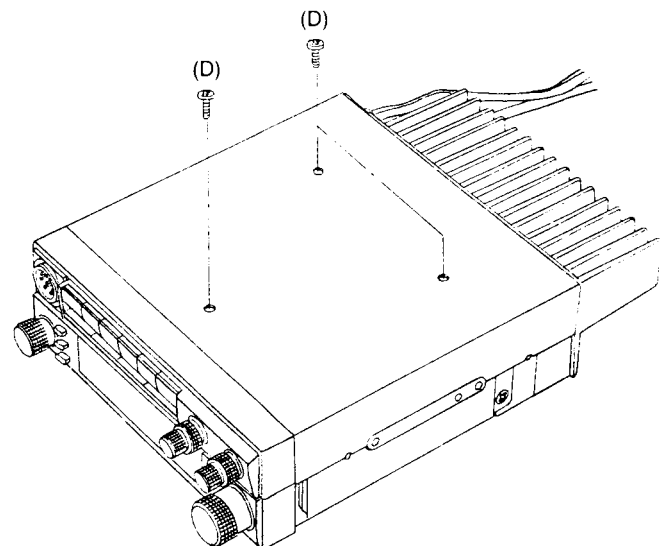

Removing UHF (430 M) Main PCB

- (1) Remove 6 screws (E).
- (2) Unplug 5 connectors (CN A, CN B, CN D, CN E, CN F) and 2 pins (PJ1, PJ2), and remove Tone (CTCSS) PCB.

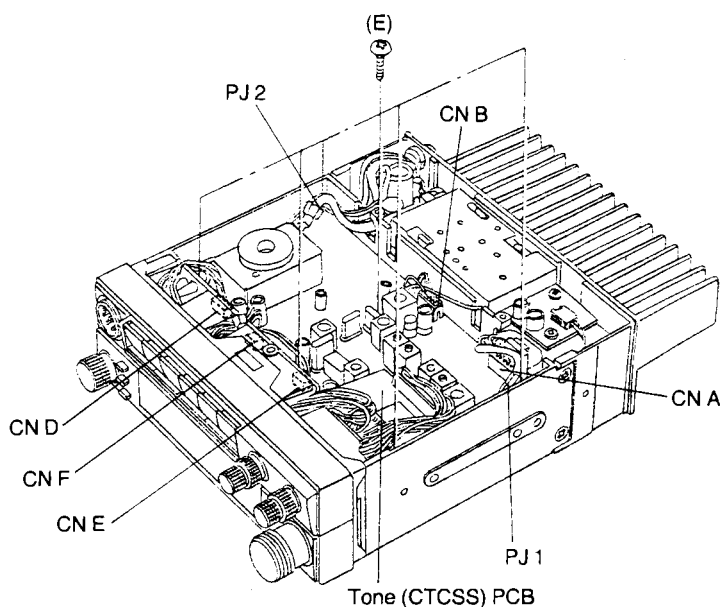

Removing Crystal Converter PCB

- (1) Remove 4 screws (F).
- (2) Unplug 2 connectors (CN X, CN Y).

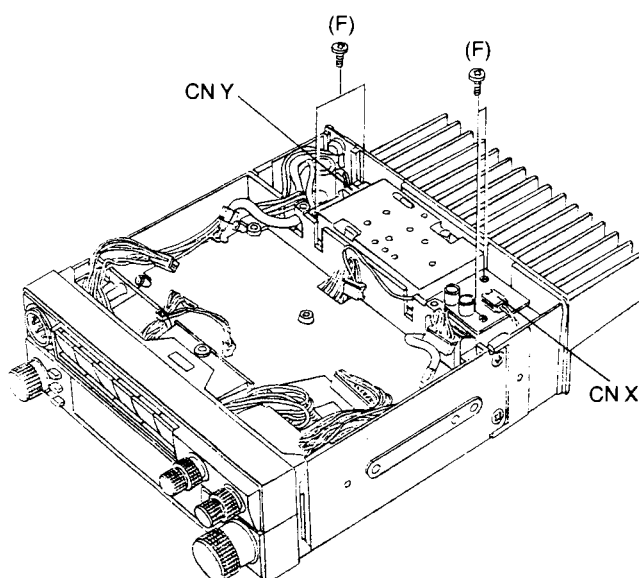

Removing Shield Plate beneath Crystal Converter PCB

- (1) Remove 4 screws (G).

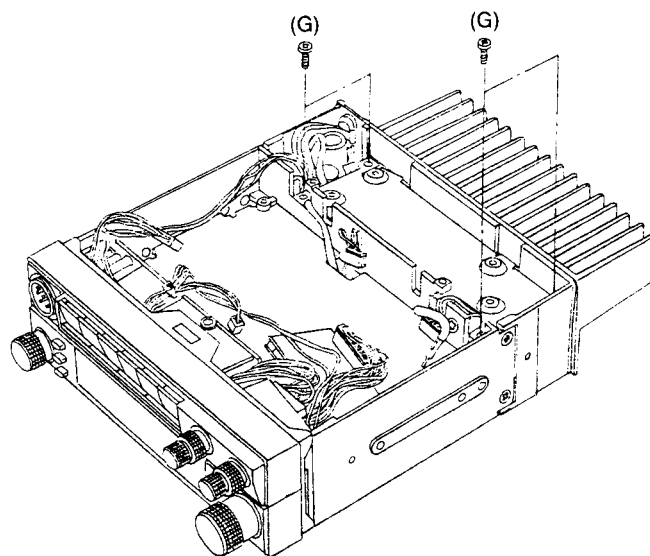

Removing Front Panel

- (1) Remove 4 knobs (H).
- (2) Release 3 hooks (I).
- (3) Remove 2 nuts (Z).

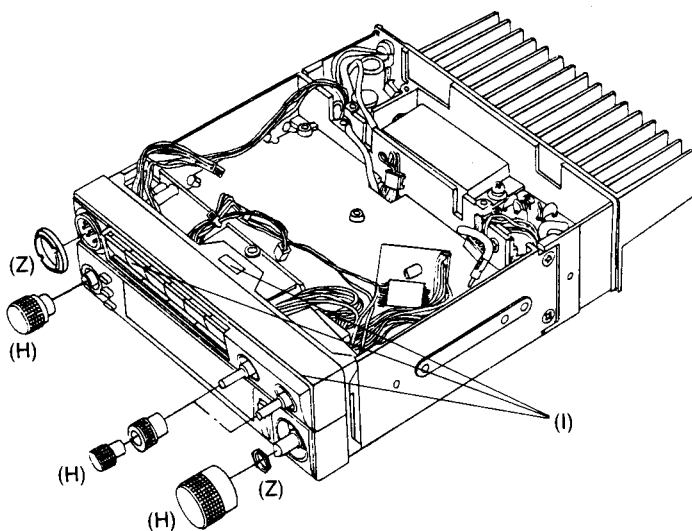

Removing CPU PCB

- (1) Remove 4 screws (J).

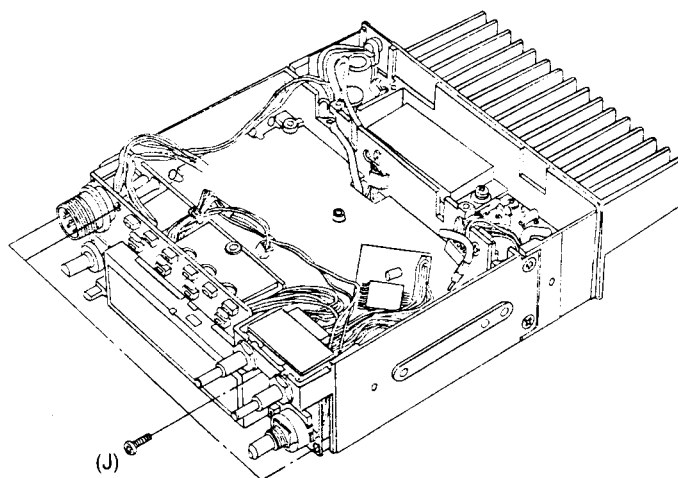

Removing VOL PCB

- (1) Place Unit upright, and remove 2 nuts (K).
- (2) Disconnect connector (CN N).

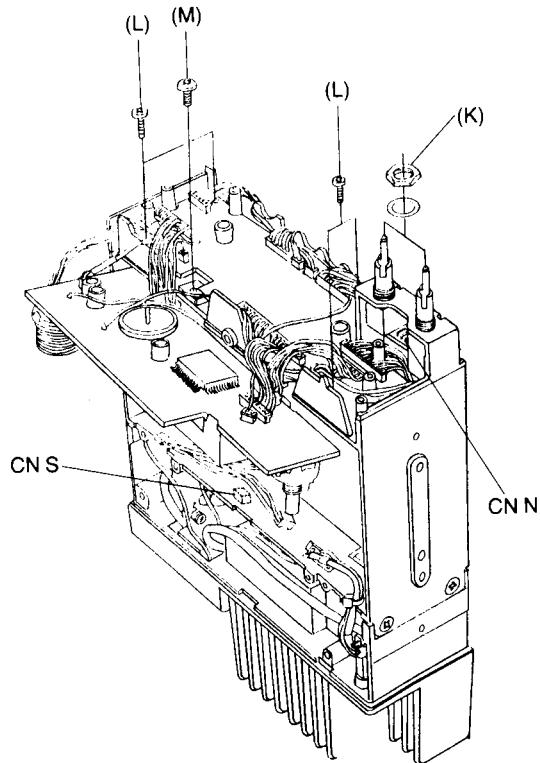

Removing Control PCB

- (1) Remove 4 screws (L) and one screw (M).
- (2) Unplug connector (CN S) on Power Supply PCB at the bottom.

Removing Rear Assembly

- (1) Remove 4 screws (N).

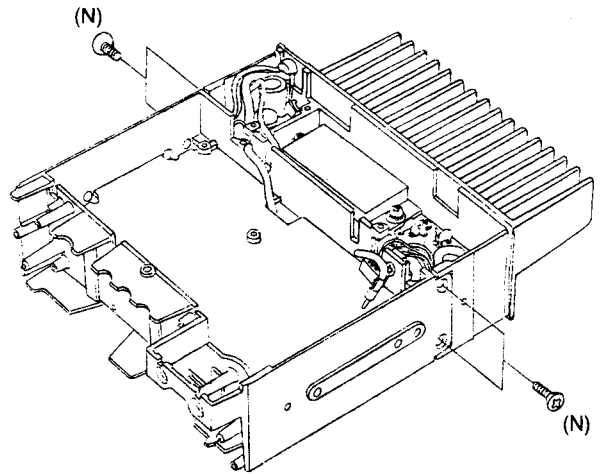

Removing Power Supply PCB

- (1) Turn over assembly, and remove 2 screws (O).
- (2) Disconnect soldered portion (P).
- (3) Remove 6 screws (Q), 2 screws (R), 1 screw (S), and Disconnect 2 soldered portions (T).

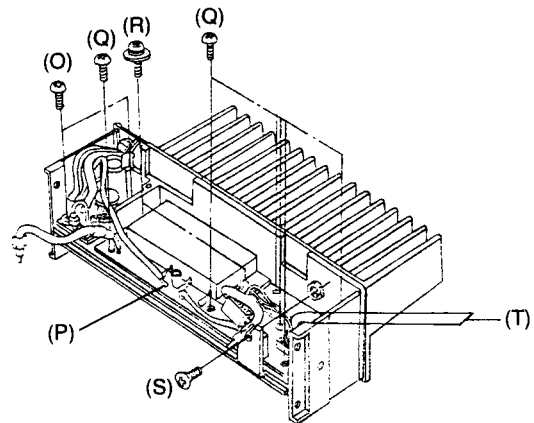

Removing Duplexer PCB

- (1) Turn over Unit, and remove 6 screws (U).
- (2) Disconnect 2 soldered portions (V).

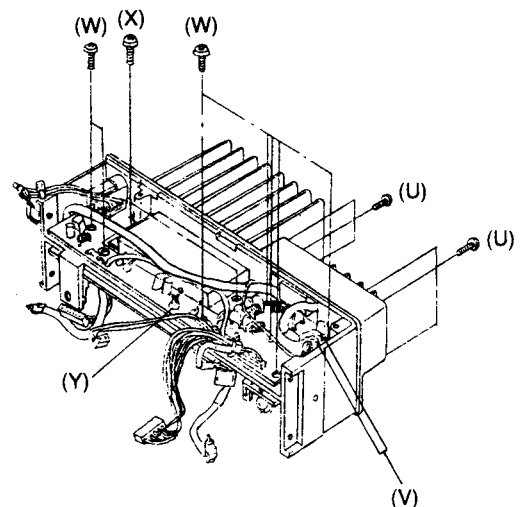

Removing VHF Final and UHF Final PCBs

- (1) Remove 7 screws (W), 2 screws (X), and Disconnect soldered portion (Y).

■ CABINET PARTS LOCATION

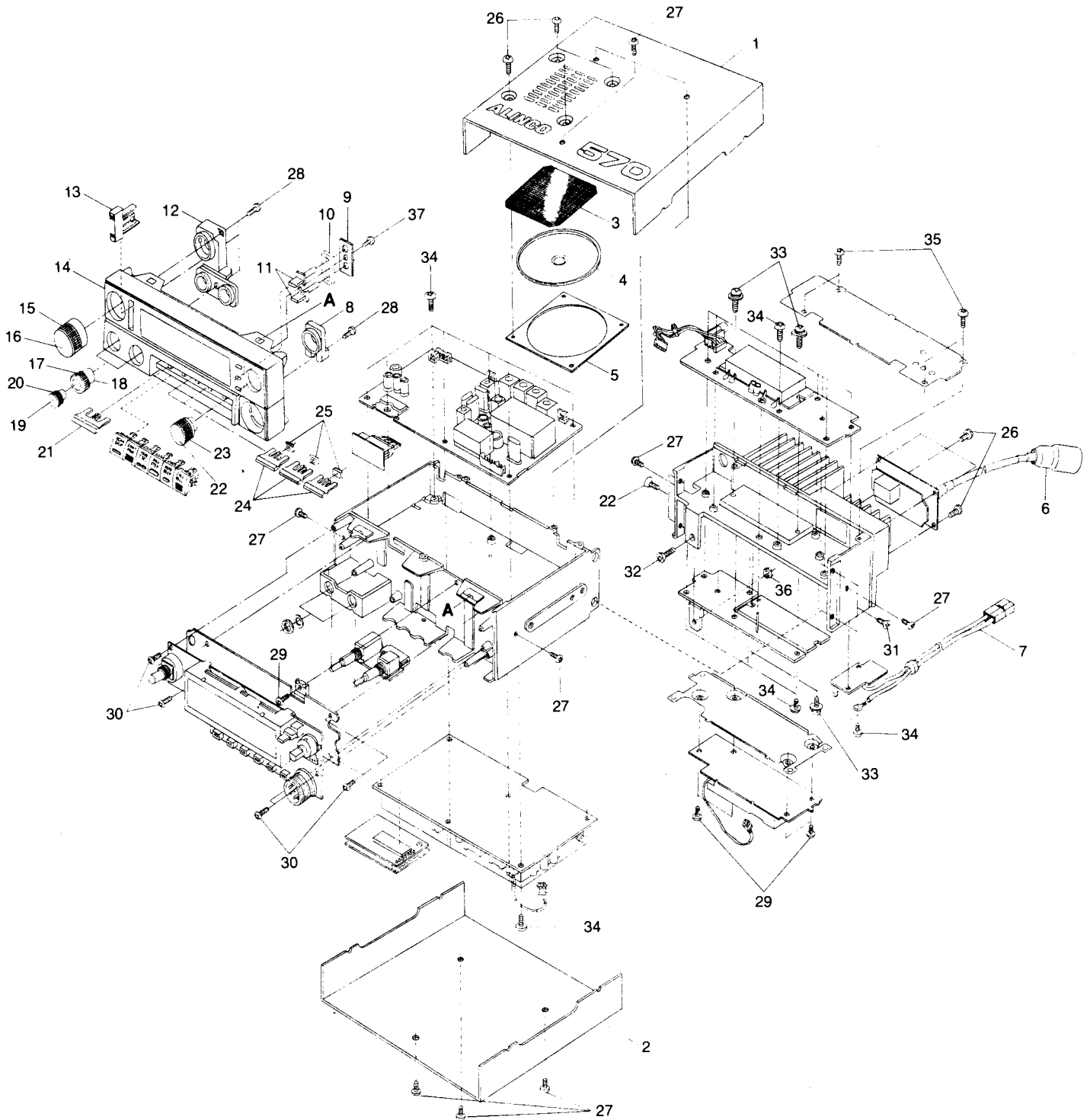

Ref. No.	Part Code	Part Name and Number
Mechanical Parts		
1	KU0061	Upper Case
2	KS0033	Lower Case
3	FF0013	SP Sheet
4	ES0001	Speaker 57S38-1
5	ST0009	SP Metal Crasp
6	UE0082	Coaxial Cable
7	UA0002	DC Power Cable
8	DG0009	Encoder light (S) 32G0009
9	FM0030	TS Plate 37M0030
10	FG0043	Tact Knob Sponge 37G0043
11	NB0023	Tact Switch Knob 33B0023
12	DG0008	Encoder light (L) 32G0008

Ref. No.	Part Code	Part Name and Number
13	NB0024	UD Knob 33B0024
14	KM0059A	Front Panel
15	ND0009	Dial Rubber (L)
16	NK0011	Dial Knob (L)
17	ND0012	Squelch Rubber
18	NW0003	Squelch Knob
19	NK0013	Volume Knob
20	ND0011	Volume Rubber
21	NB0025	Light Knob (L) 33B0025
22	NK0012	Dial Knob (S)
23	ND0010	Dial Rubber (S)
24	NB0026	Light Knob (S) 33B0026
25	FG0042	Light Knob Sponge 37G0042

Ref. No.	Part Code	Part Name and Number
Screws		
26	AA0003	M2.6×5
27	AA0008	M2.6×6
28	AP0006	M2×6
29	AA0030	M2.6×5
30	AA0027	M2×4
31	AA0022	M3×6
32	AA0029	M3×10
33	AD0001	M3×8
34	AJ0015	2.6×6 (tap)
35	AF0011	M2.6×4
36	AN0010	Nut M3-1
37	AF0012	M2×4

■ ADJUSTMENT (VHF)

Item	Adjustment point(s)	Adjustment method
VCO Voltage	<input type="checkbox"/> TC1 TC2 (VCO BOX)	At 445.000 MHz (T) or 435.000 MHz (E), adjust TC1 so that the voltage of TP3 on <input type="checkbox"/> substrate is 1.8 V.
		At 445.000 MHz (T) or 435.000 MHz (E), pressing the PTT button, adjust TC2 so that the voltage of TP3 on <input type="checkbox"/> substrate is 3.8 V.
	<input type="checkbox"/> L4 (VCO BOX)	At 145.000 MHz, adjust TP2 so that the voltage of TP2 on <input type="checkbox"/> substrate is 4.0 V.
Basic Frequency	<input type="checkbox"/> TC1	Pressing PTT button, adjust TC1 so that f-counter indicates 444.950 ±0.1 kHz (T) or 434.950 ±0.1 kHz (E) MHz.
TX Power	<input type="checkbox"/> VR2 VR3	On "LO" position, pressing the PTT button, adjust VR2 and VR3 so that the power is maximum at 145.95 MHz (T) or 144.95 MHz (E).
Power Output	<input type="checkbox"/> VR2 (Hi)	On "Hi" position, turn VR2 for 46 W output at 145.95 MHz (T) or 144.95 MHz (E). Verify the lighting of the entire RF meter.
	<input type="checkbox"/> VR4 (Lo)	On "Lo" position, turn VR4 for 5 W output at 145.95 MHz (T) or 144.95 MHz (E).
RF meter	<input type="checkbox"/> VR1	On "Lo" position, adjust VR1, so that <input type="checkbox"/> on the RF meter lights up at 145.95 MHz (T) or 144.95 (E).
Deviation	<input type="checkbox"/> VR3	Enter the AF level of OdBm, then pressing the PTT button, adjust VR3 so that you obtain 4.6 kHz/Dev at 145.95 MHz (T) or 1449.95 MHz (E) and AF 1 KHz.
Protection Circuit	<input type="checkbox"/> VR3	Disconnect the antenna, then pressing the PTT button and adjust VR3 so that the current consumption is 4.5 A at 145.95 MHz (T) or 144.95 MHz (E).
Subaudible Tone Deviation (DR-570T)		Pressing the tone button and the PTT button at 145.95 MHz, verify 0.5~1 kHz/Dev at tone frequency of 88.5 Hz.
1750 Hz Tone Deviation (DR-570E)		Connect Microphone (EHM-34A or 33A), then pressing the tone button, verify that the tone frequency is 1750 Hz and the deviation is 3.5 kHz ±0.5 kHz.
Discrimination	<input type="checkbox"/> L7, 8, 9	At 146.03 MHz (T) or 145.03 (E) and 60 dBμ input, adjust L7, 8, 9, so that the distortion is minimum at 50 m W.
Sensitivity	<input type="checkbox"/> L2, 3, 4, 5, 6	Adjust L2, 3, 4, 5, 6 so that 12 dB SINAD sensitivity is the highest at 146.03 MHz (T) or 145.03 MHz (E).
Squelch Sensitivity	<input type="checkbox"/> VR1	At 146.03 MHz (T) or 145.03 MHz (E), turn the main squelch knob to the minimum and cut SG output, then adjust VR1 so that the noise is maximum.

■ ADJUSTMENT (UHF)

Item	Adjustment point(s)	Adjustment method
VCO Voltage	<input type="checkbox"/> TC1 <input type="checkbox"/> TC2 (VCO BOX)	At 445.000 MHz (T) or 435.000 MHz (E), adjust TC1 so that the voltage of TP3 on <input type="checkbox"/> substrate is 1.8 V.
		At 445.000 MHz (T) or 435.000 MHz (E), pressing the PTT button, adjust TC2 so that the voltage of TP3 on <input type="checkbox"/> substrate is 3.8 V.
	<input type="checkbox"/> L4 (VCO BOX)	At 145.000 MHz, adjust TP2 so that the voltage of TP2 on <input type="checkbox"/> substrate is 4.0 V.
TX Power	<input type="checkbox"/> VR5	On "Lo" position, pressing the PTT button, adjust VR5 so that the power is maximum at 444.95 MHz (T) or 434.95 MHz (E).
Power Output	<input type="checkbox"/> VR5 (Hi)	On "Hi" position, turn VR5 for 35 W output at 444.95 MHz (T) or 36 W output at 434.95 MHz (E). Verify the lighting of the entire RF meter.
	<input type="checkbox"/> VR7 (Lo)	On "Lo" position, turn VR7 for 5 W output at 444.95 MHz (T) or 434.95 (E).
RF meter	<input type="checkbox"/> VR6	On "Lo" position, adjust VR1 so that <input type="checkbox"/> on the RF meter lights up at 444.95 MHz (T) or 434.95 MHz (E).
Deviation	<input type="checkbox"/> VR3	Enter the AF level of OdBm, then pressing the PTT button, adjust VR3 so that you obtain 4.6 KHz/Dev at 444.95 MHz (T) or 434.95 MHz (E) and AF 1 kHz.
Subaudible Tone Deviation (DR-570T)		Pressing the tone button and the PTT button at 444.95 MHz, verify 0.5~1 kHz/Dev at tone frequency of 88.5 Hz.
1750 Hz Tone Deviation (DR-570E)		Connect Microphone (EHM-34A or 33A), then pressing the tone button, verify that the tone frequency is 1750 Hz and the deviation is 3.5 (± 0.1) kHz.
Helical Filter	<input type="checkbox"/> TC1, 2 L3, 4	Connect a tracking generator to the antenna and a spectrum analyser to TP1, then adjust TC1, 2 and L3, 4 so that the sensitivity is at its peak between 440 and 450 MHz at maximum gain. (570 E: 430–440 MHz)
Discrimination	<input type="checkbox"/> L9, 11	At 445.03 MHz (T) or 435.03 MHz (E) and 60 dB μ input, adjust L9, 11 so that the distortion is minimum at 50m W.
Sensitivity	<input type="checkbox"/> L8, TC3	Adjust L8 and TC3 so that 12 dB SINAD sensitivity is the highest at 445.03 MHz (T) or 435.03 MHz (E).
Squelch	<input type="checkbox"/> VR1	1) At 146.03 MHz (T) or 145.03 MHz (E) of the main band, cut the SG output power and adjust the main squelch knob so that the noise is intermittent. 2) At 445.03 MHz (T) or 435.03 MHz (E) of the main band, cut the SG output power and adjust VR1 so that the noise is intermittent.
S-meter	<input type="checkbox"/> VR2	At 445.03 MHz (T) or 435.03 MHz (E) and -3 dB μ [EMF], adjust VR2 so that <input type="checkbox"/> in the S-meter begins to light.

■ BLOCK DIAGRAM

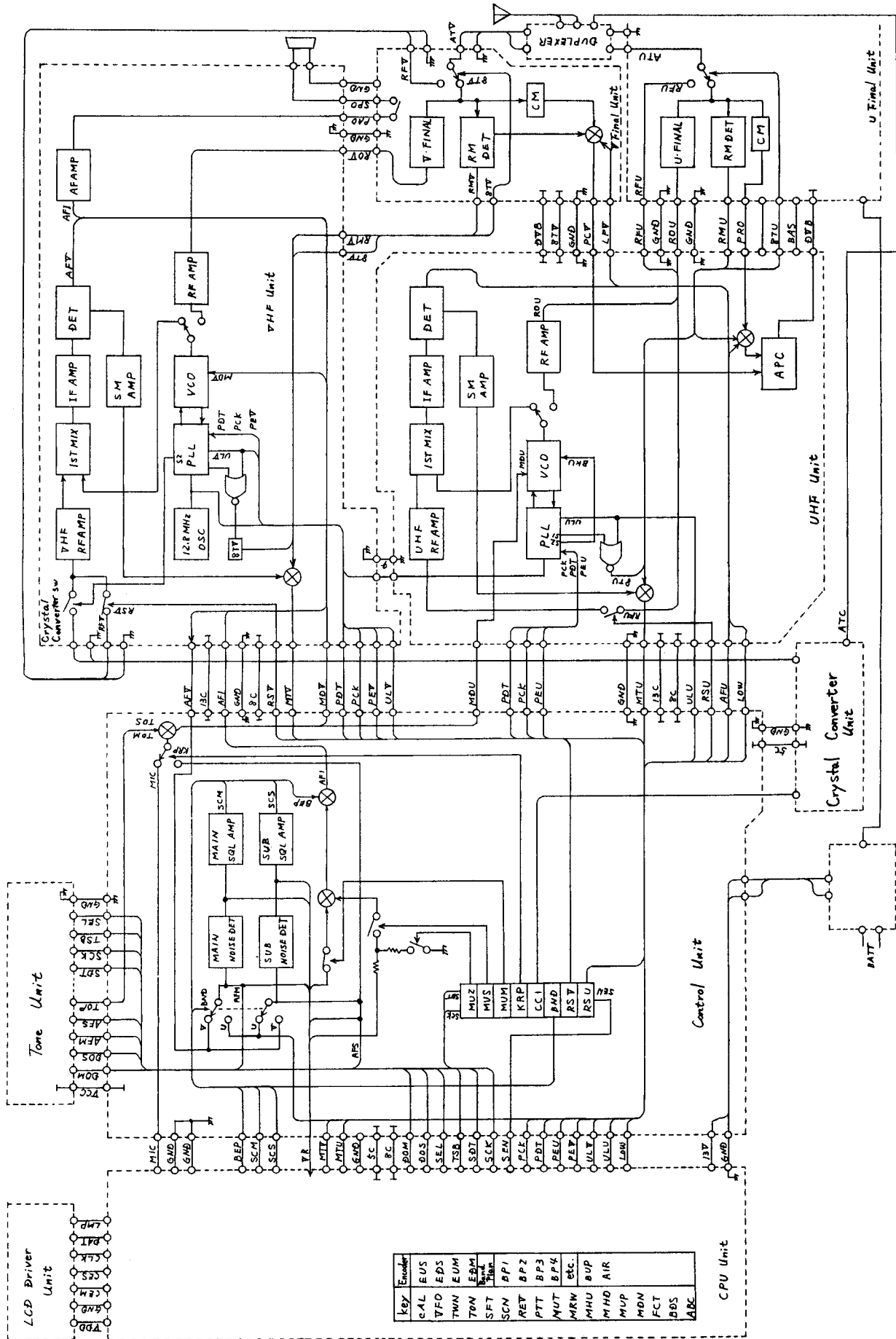

CONNECTION DIAGRAM

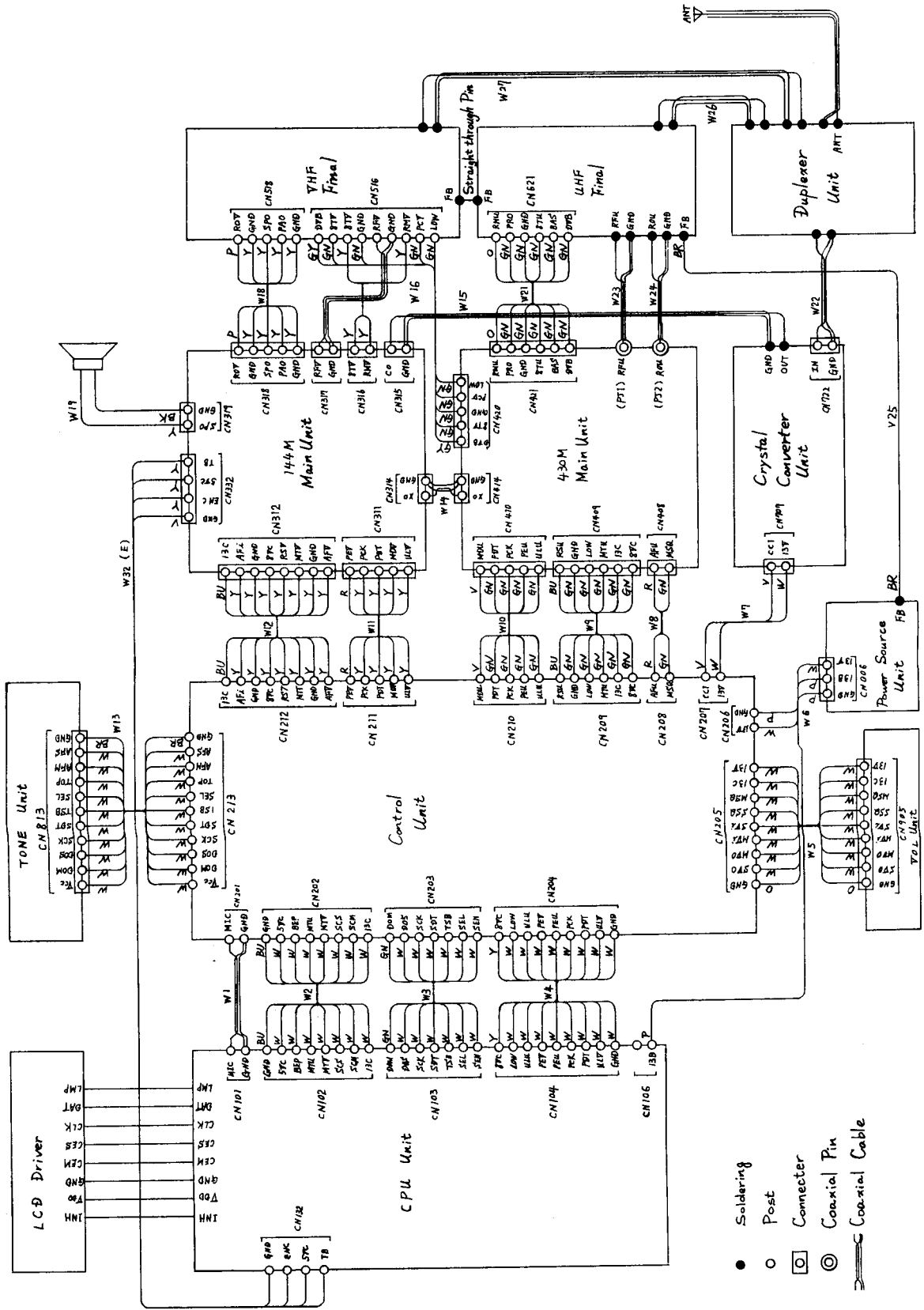

VHF MAIN SCHEMATIC DIAGRAM

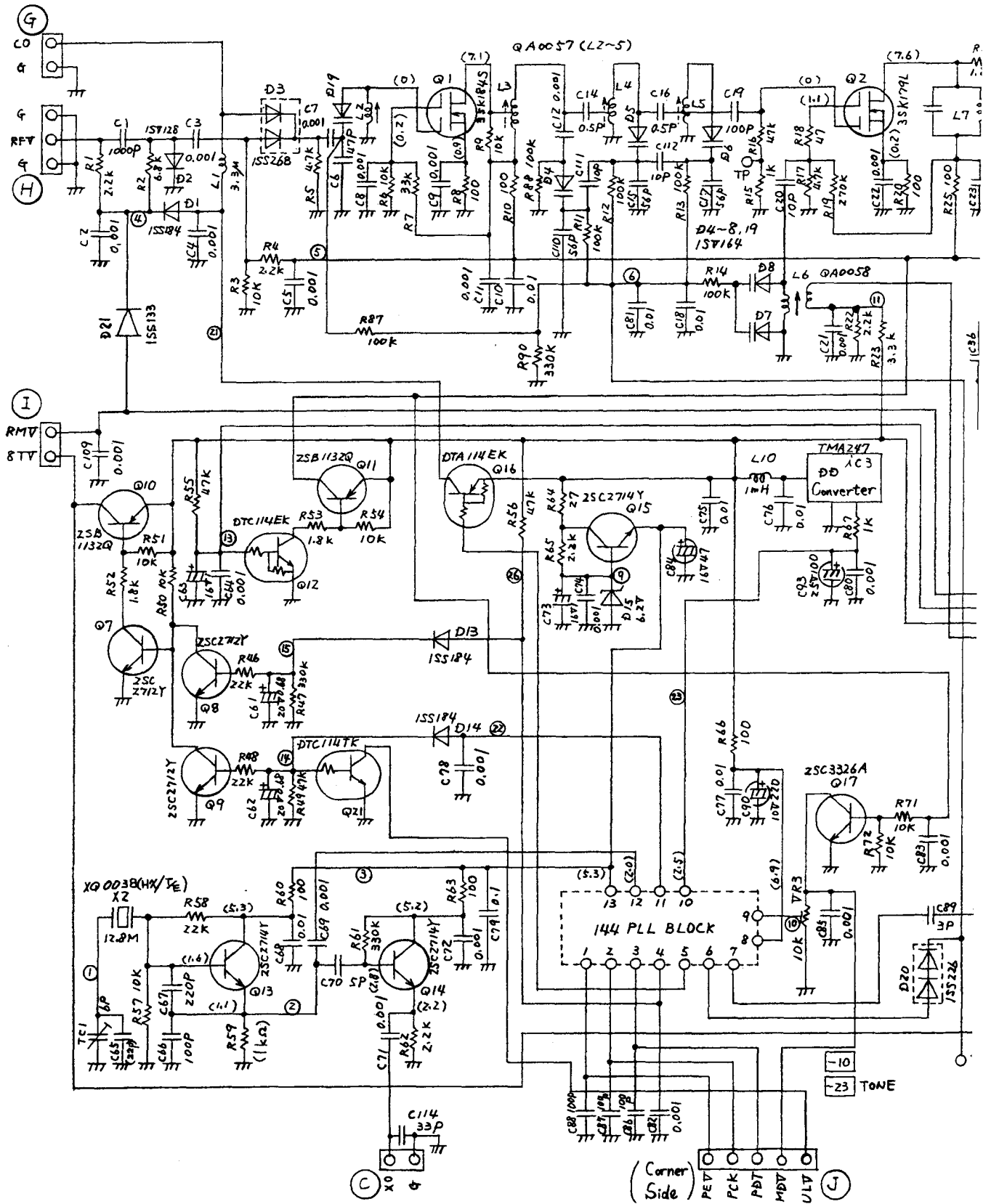

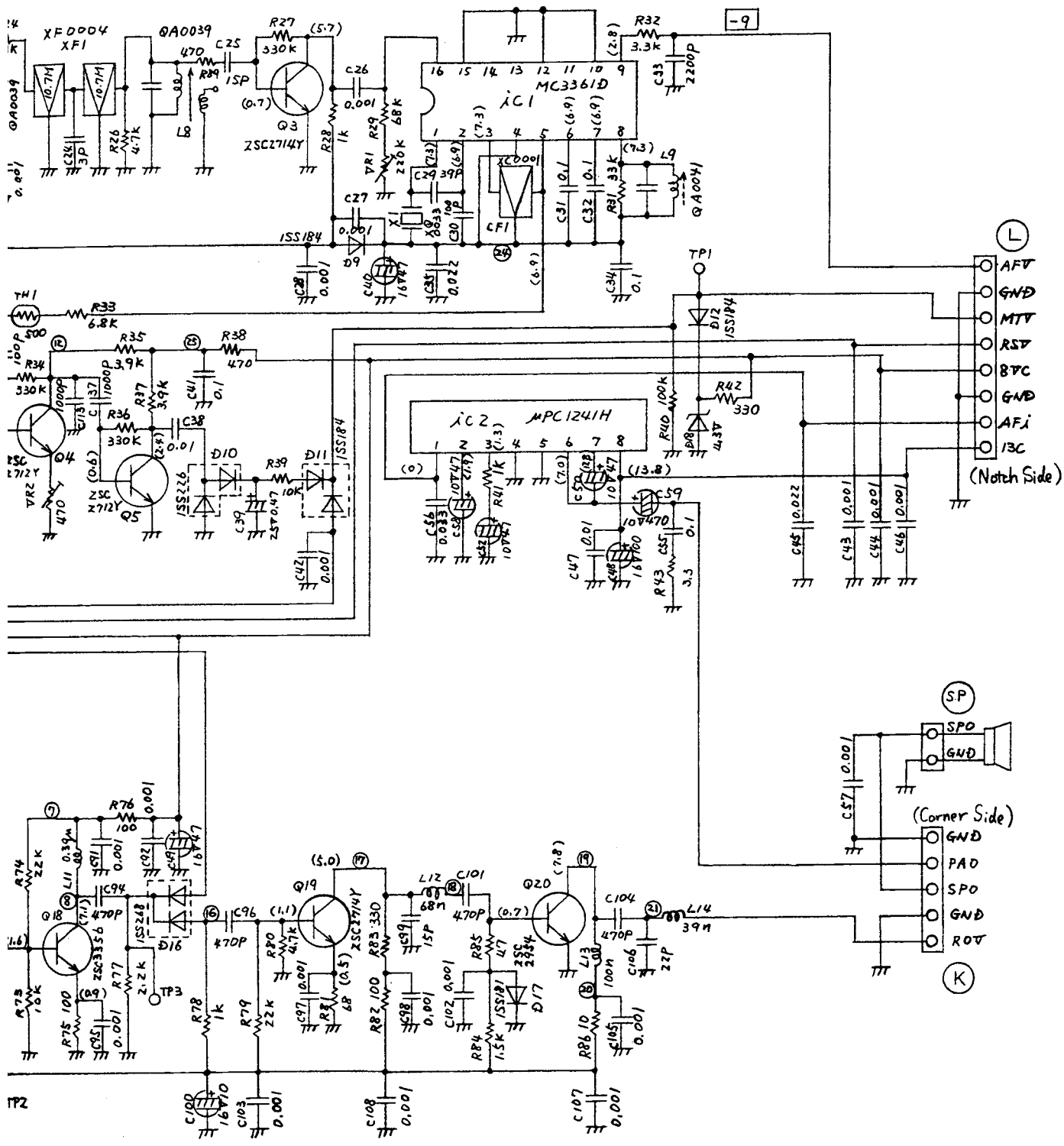

A

UHF MAIN SCHEMATIC DIAGRAM

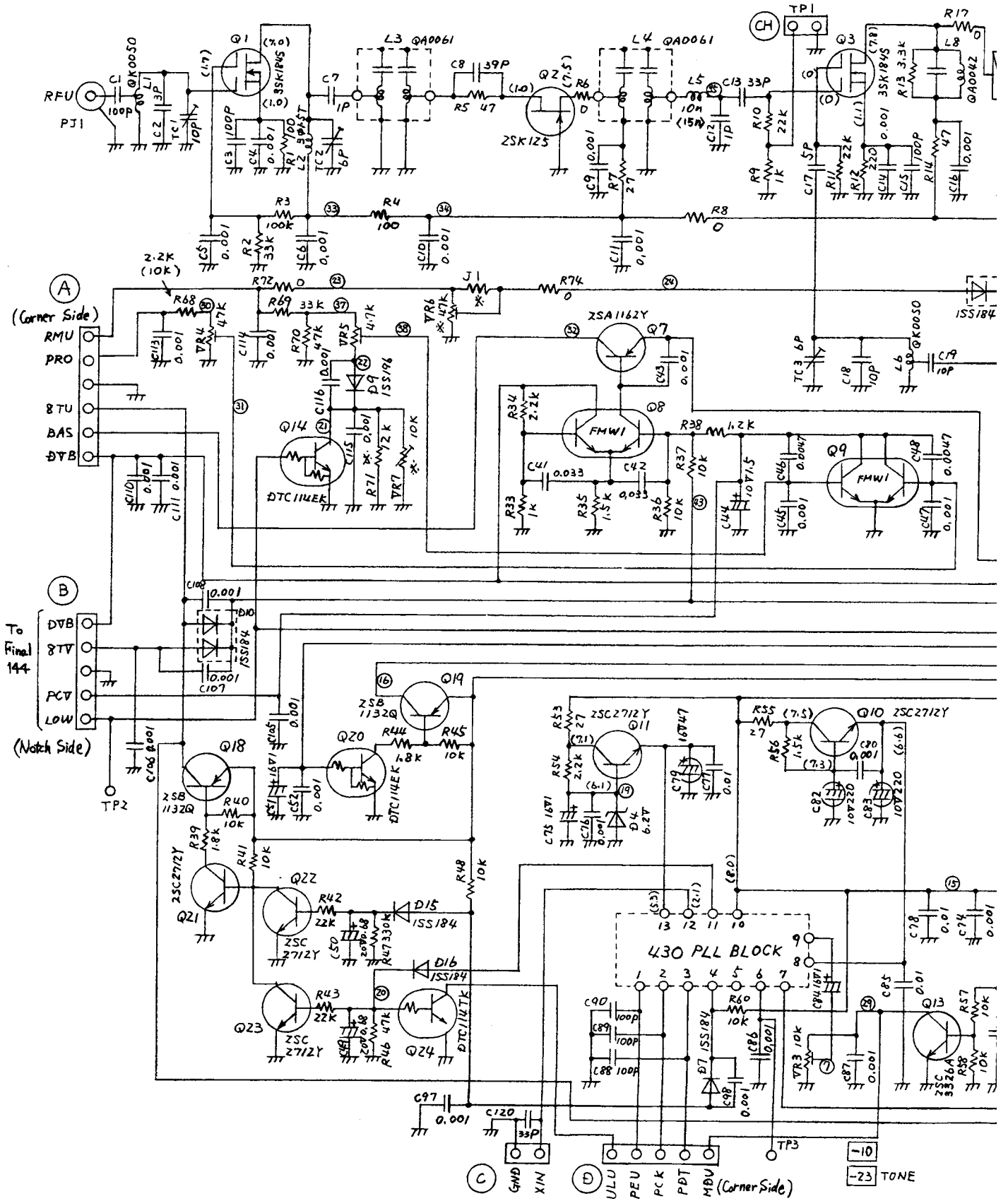

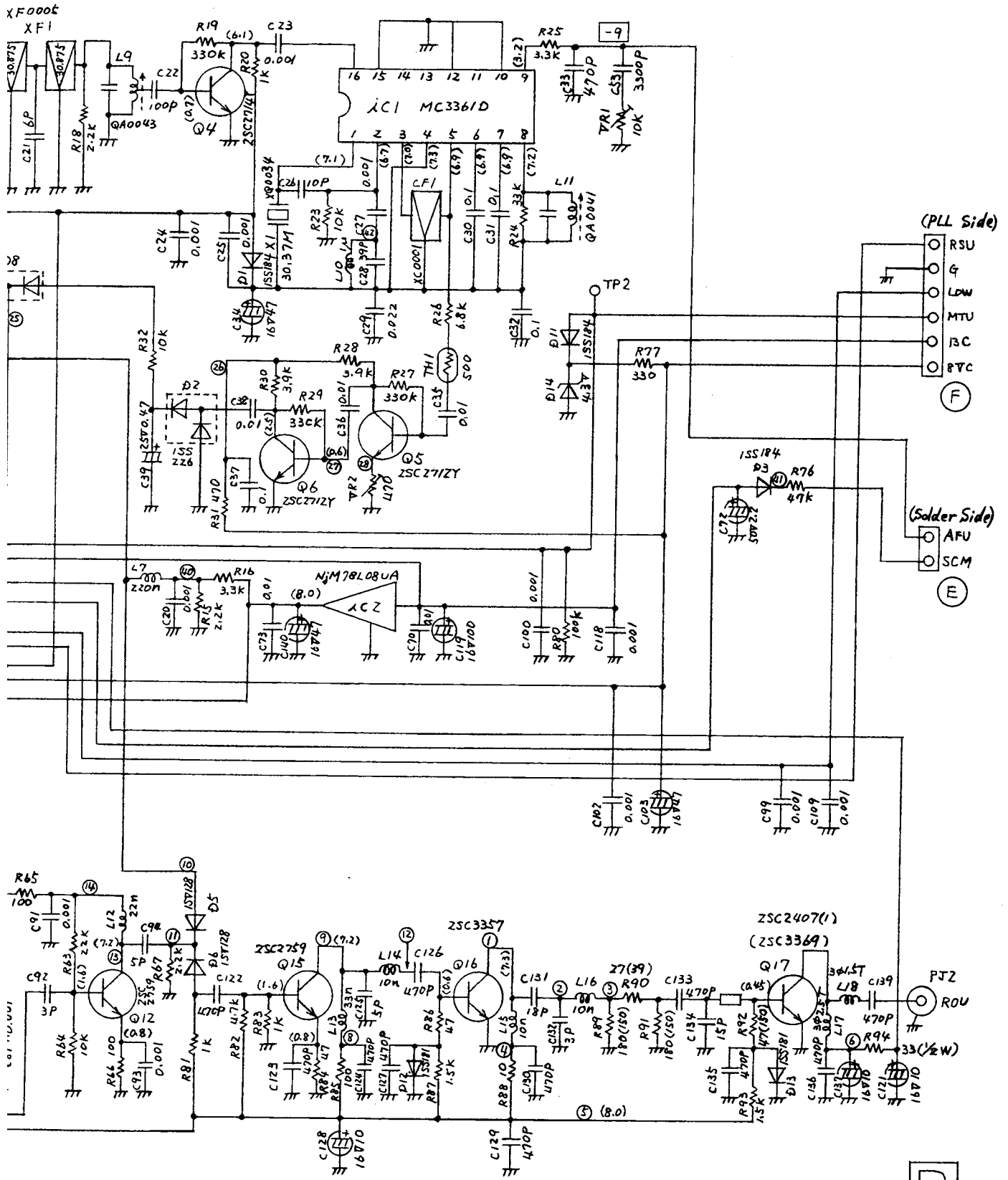

< > : T
 () : HX



VHF MAIN PC BOARD

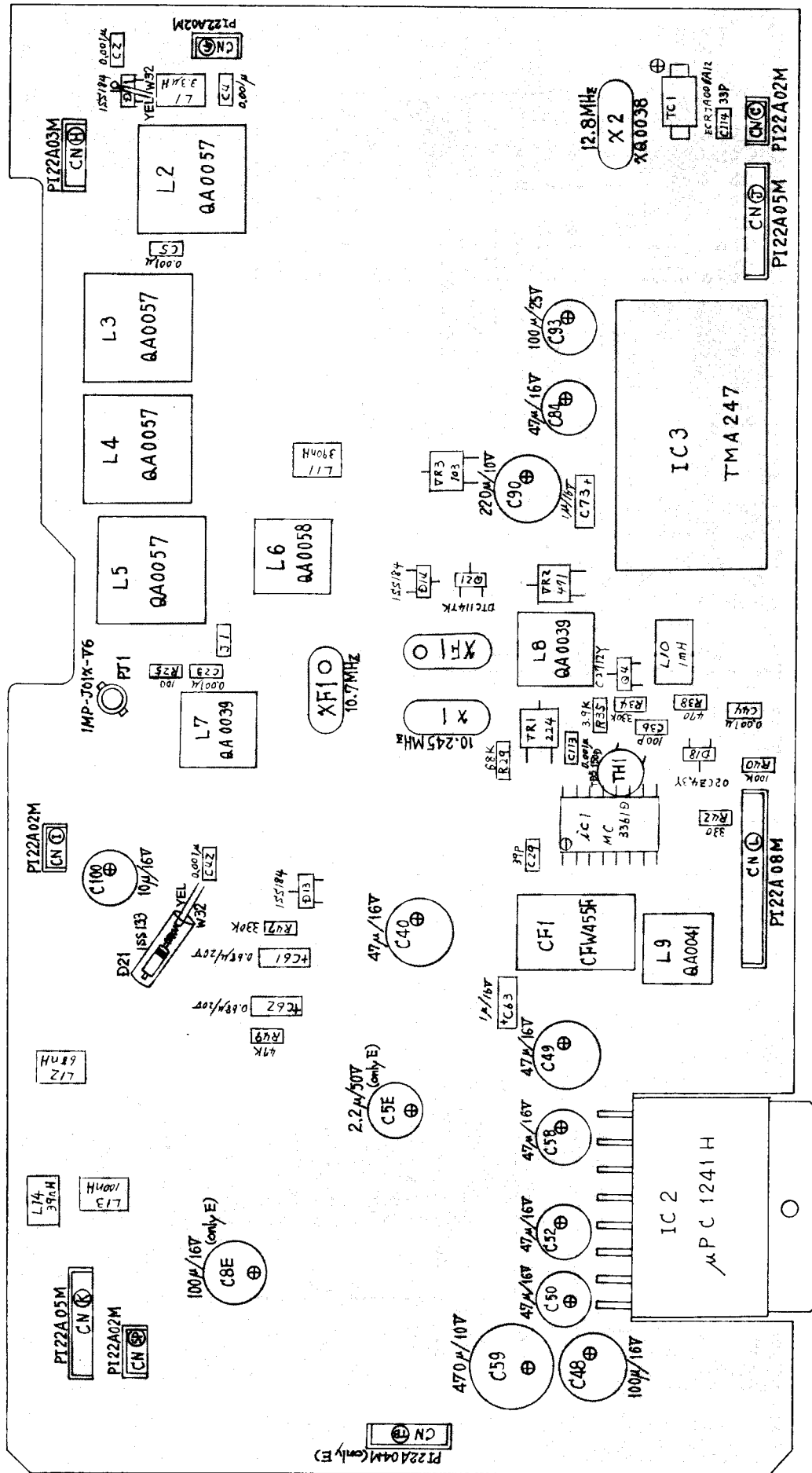

(Part)

■ VHF MAIN PC BOARD

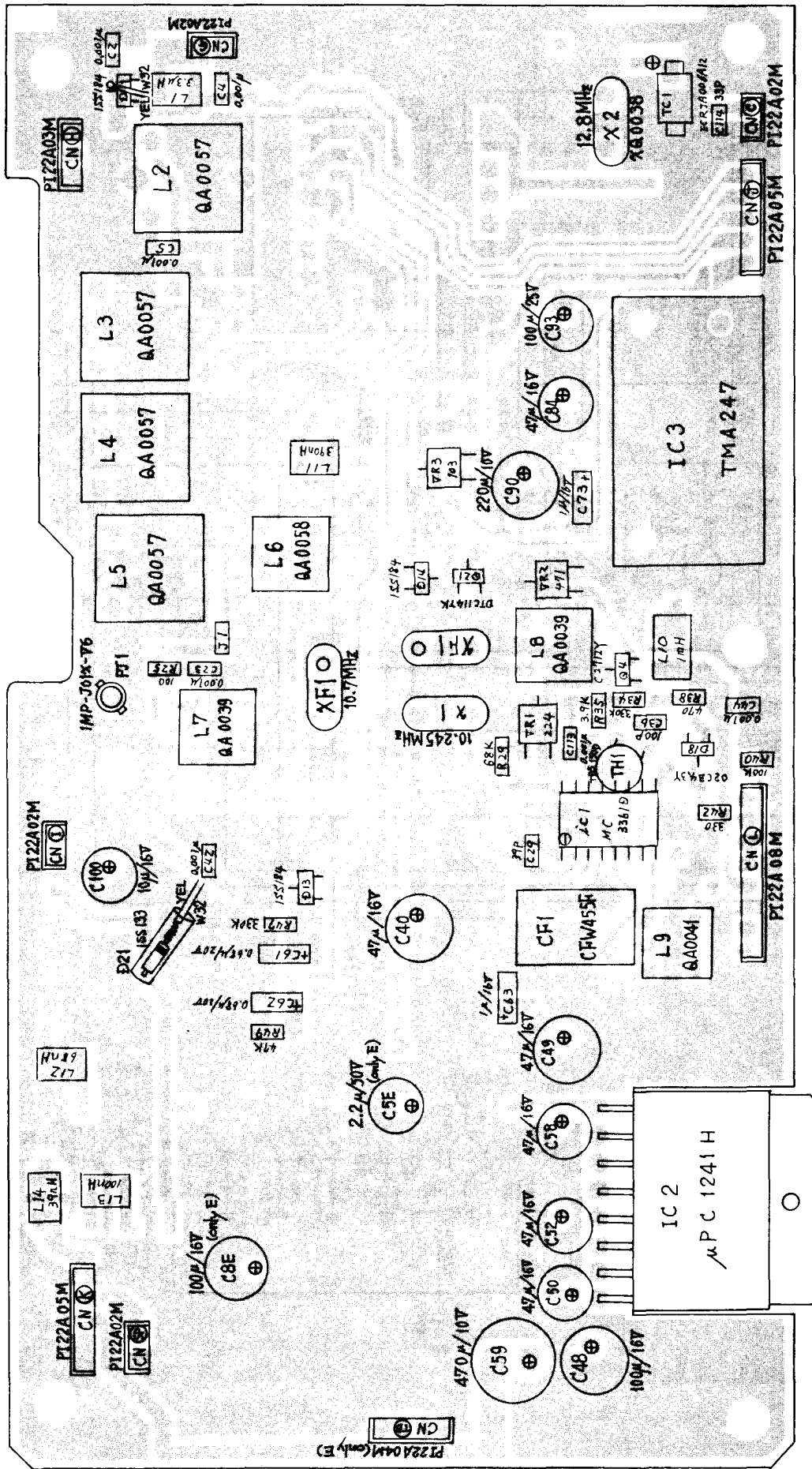

(Part)

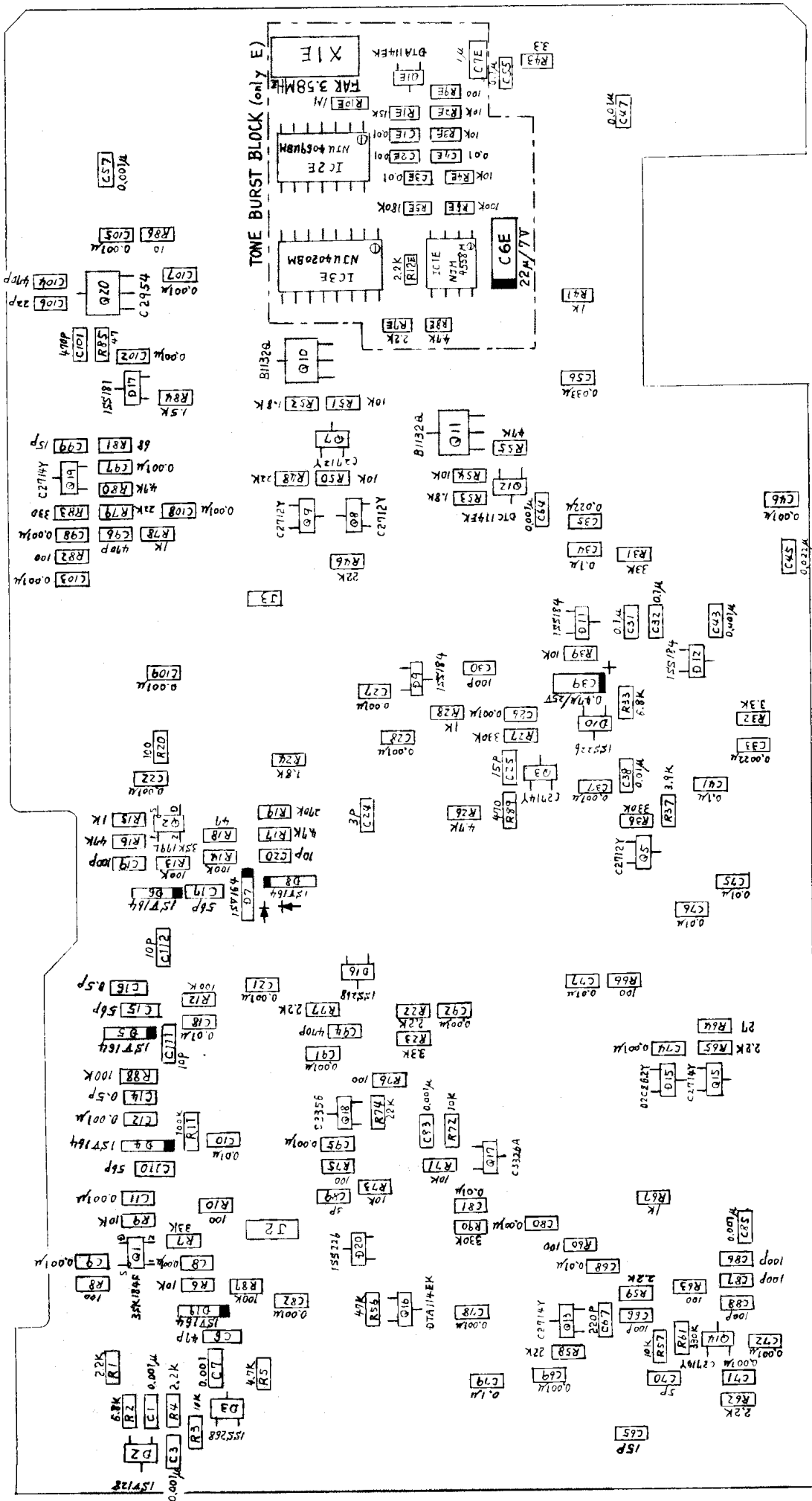

(Solder)

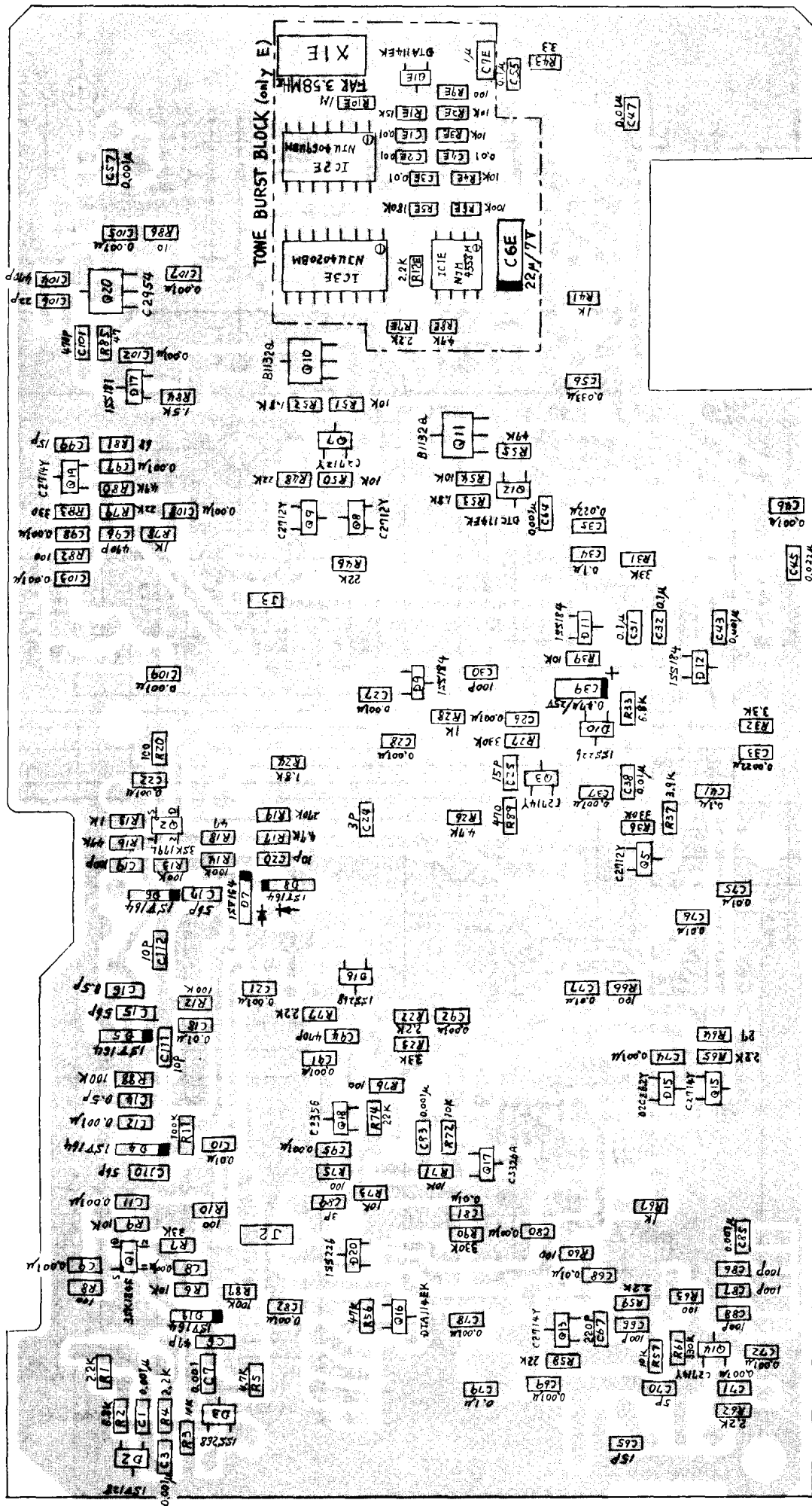

(Solder)

UHF MAIN PC BOARD

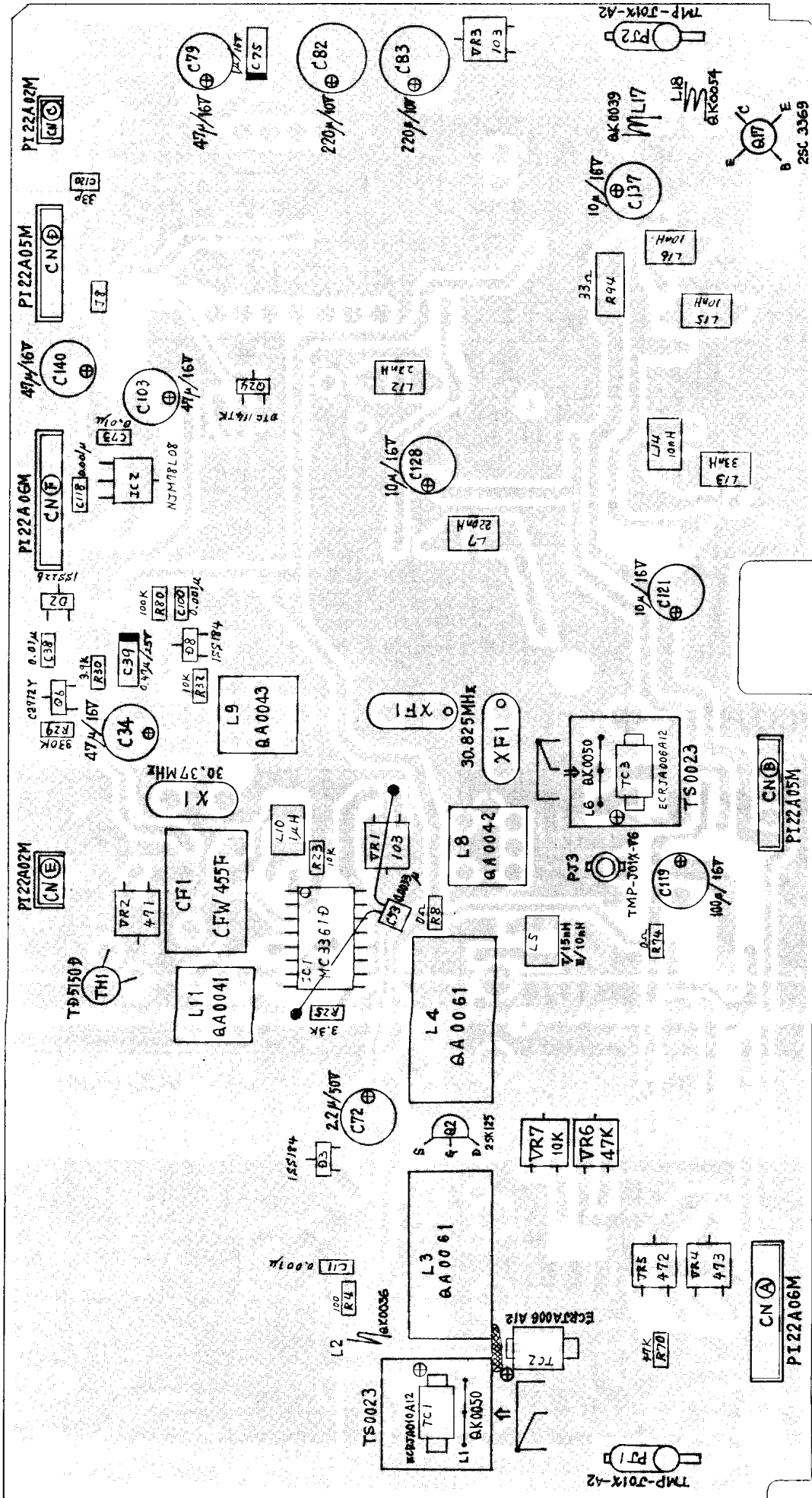

(Part)

UHF MAIN PC BOARD

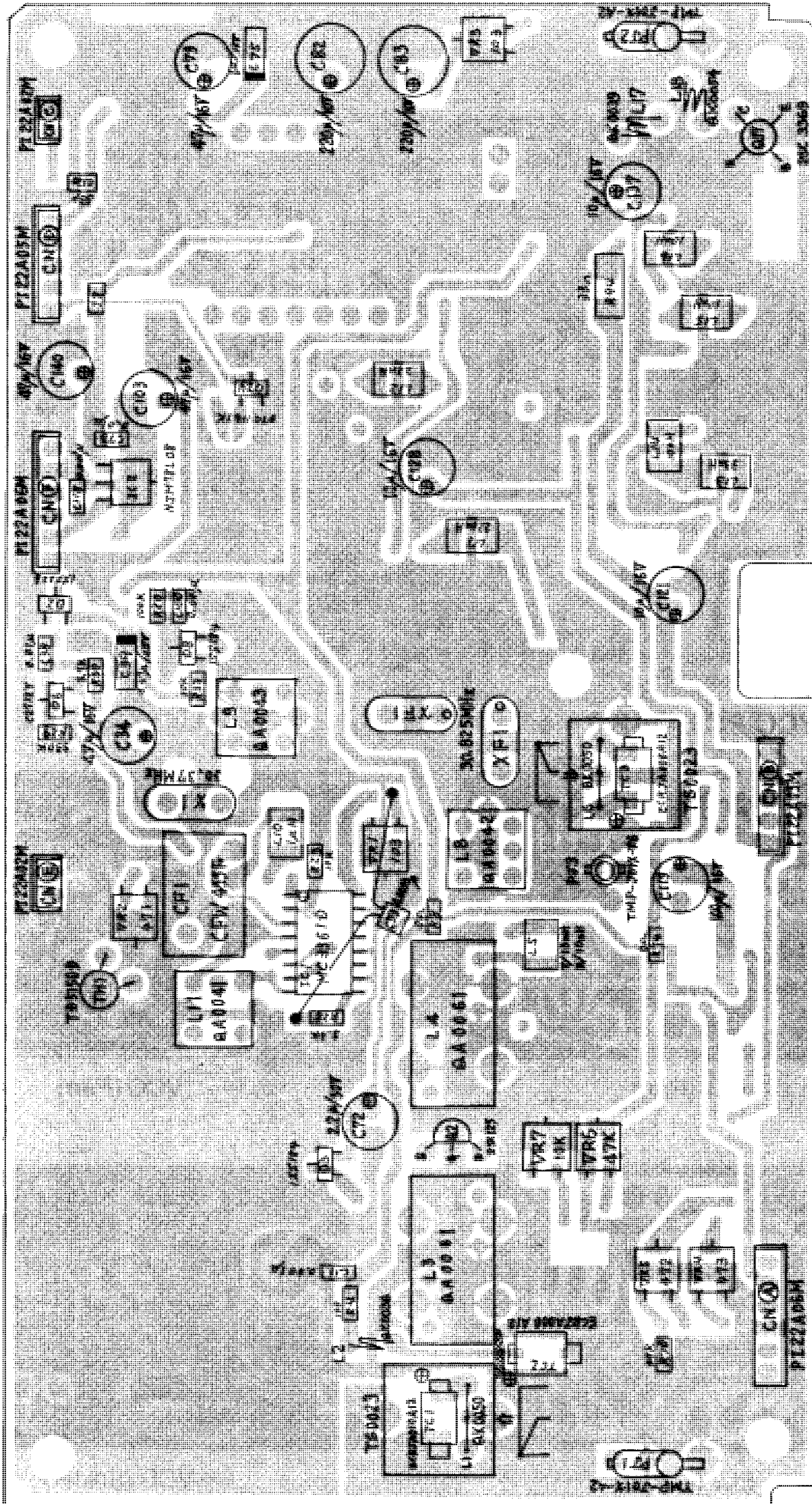

(Part)

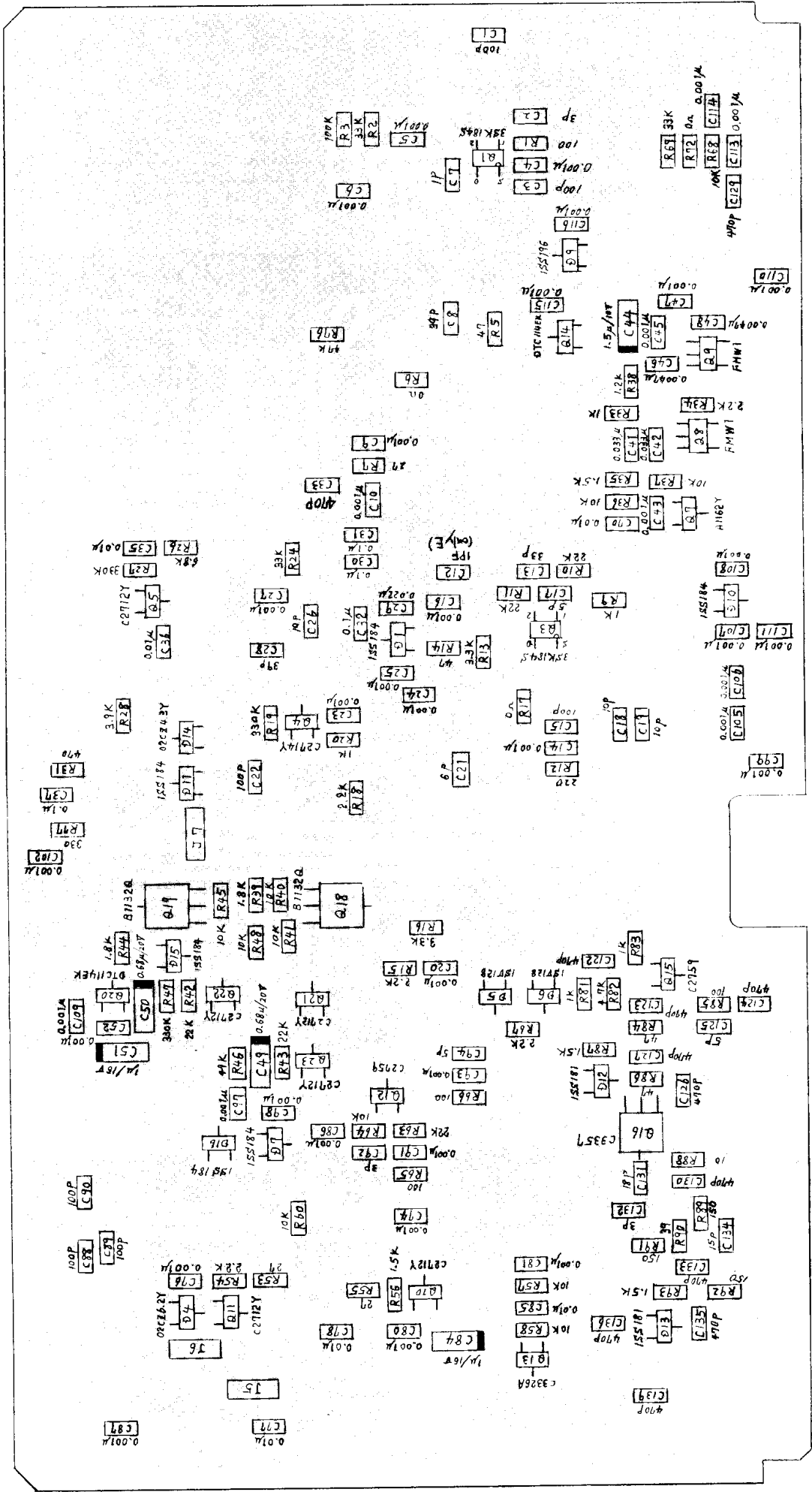

(Solder)

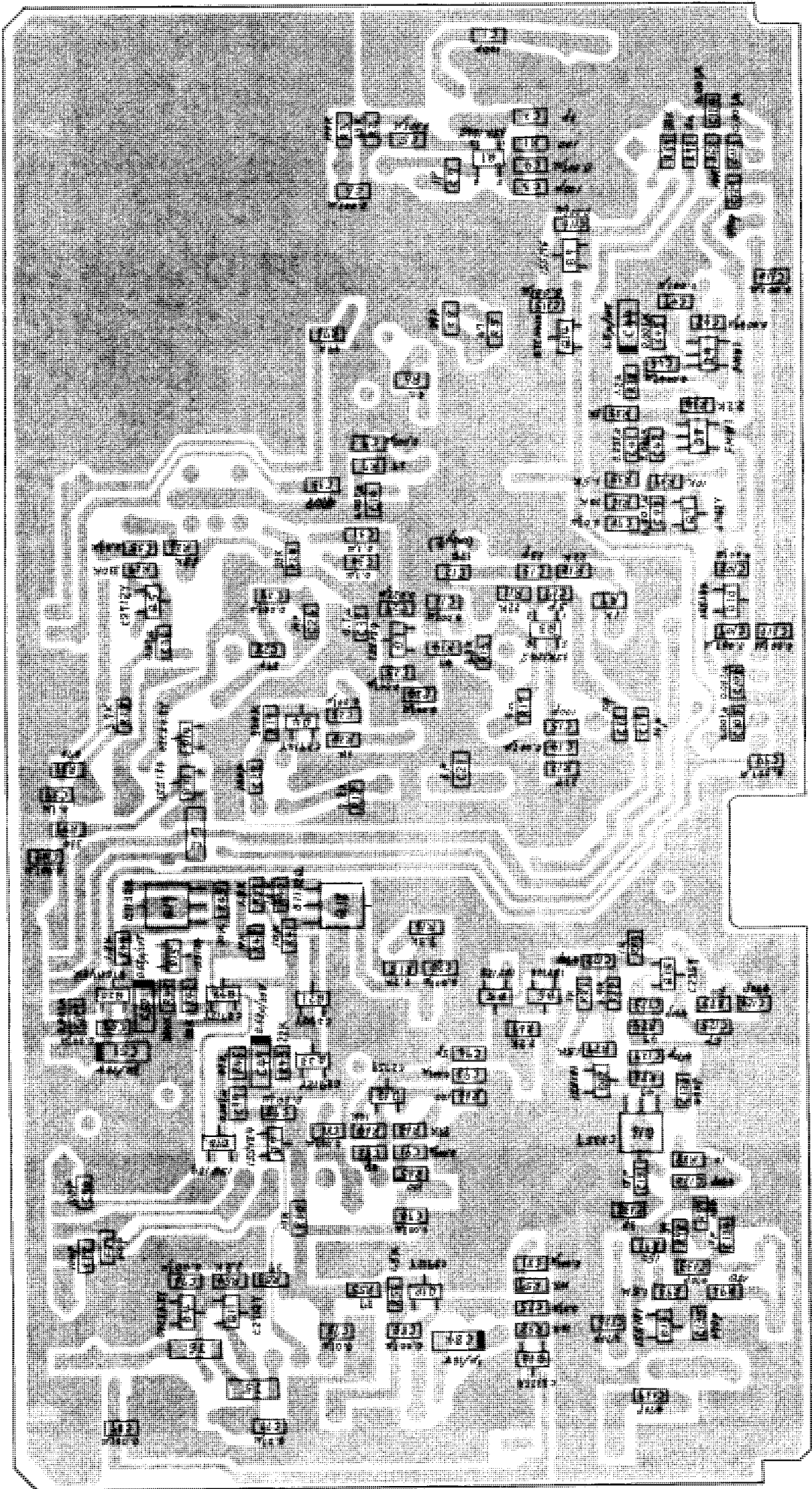

(Solder)

■ VHF PLL, VCO SCHEMATIC DIAGRAM

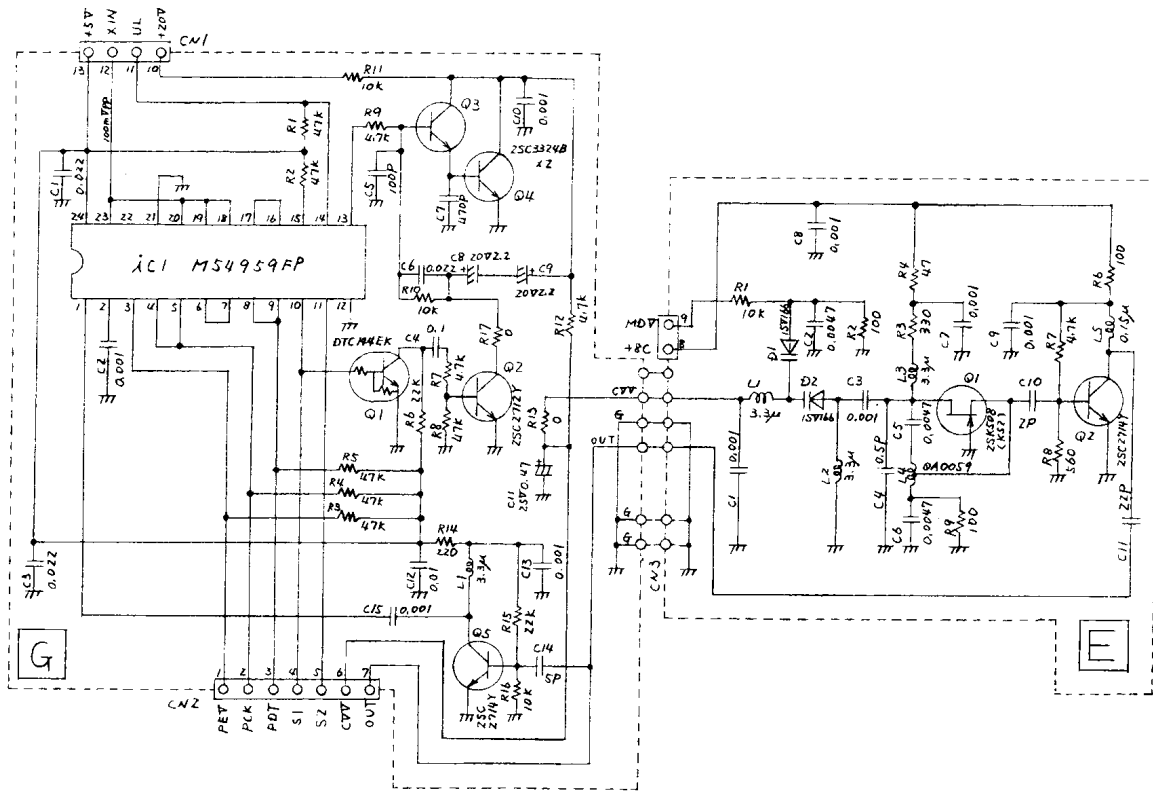

■ VHF PLL, VCO PC BOARD

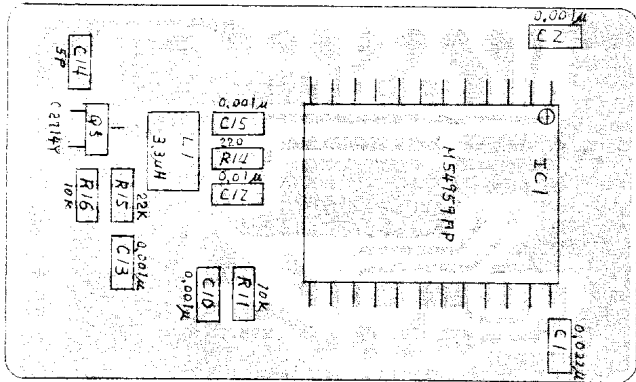

PLL (Part)

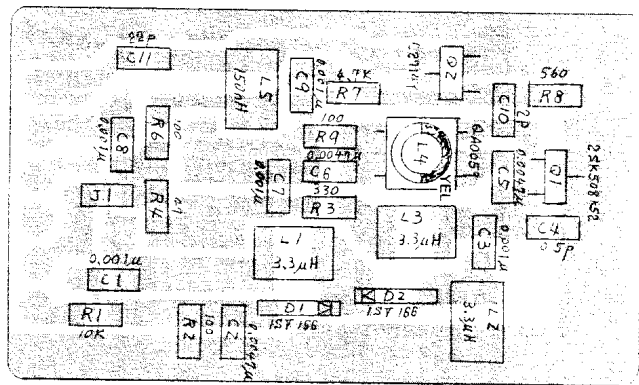

VCO (Part)

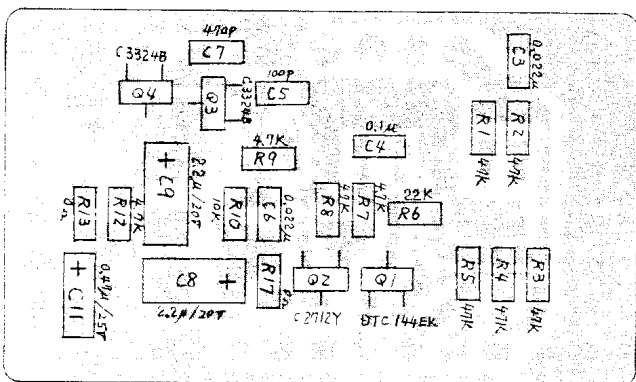

PLL (Solder)

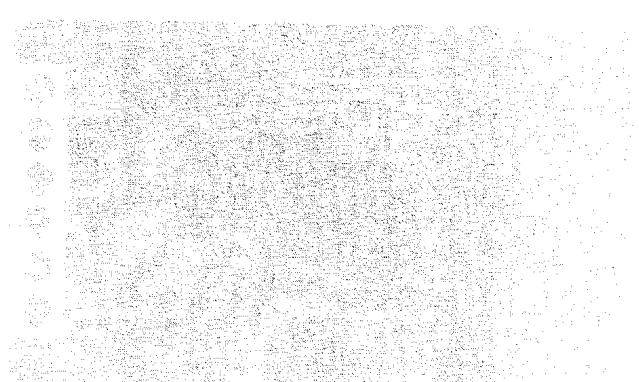

VCO (Solder)

■ VHF PLL, VCO SCHEMATIC DIAGRAM

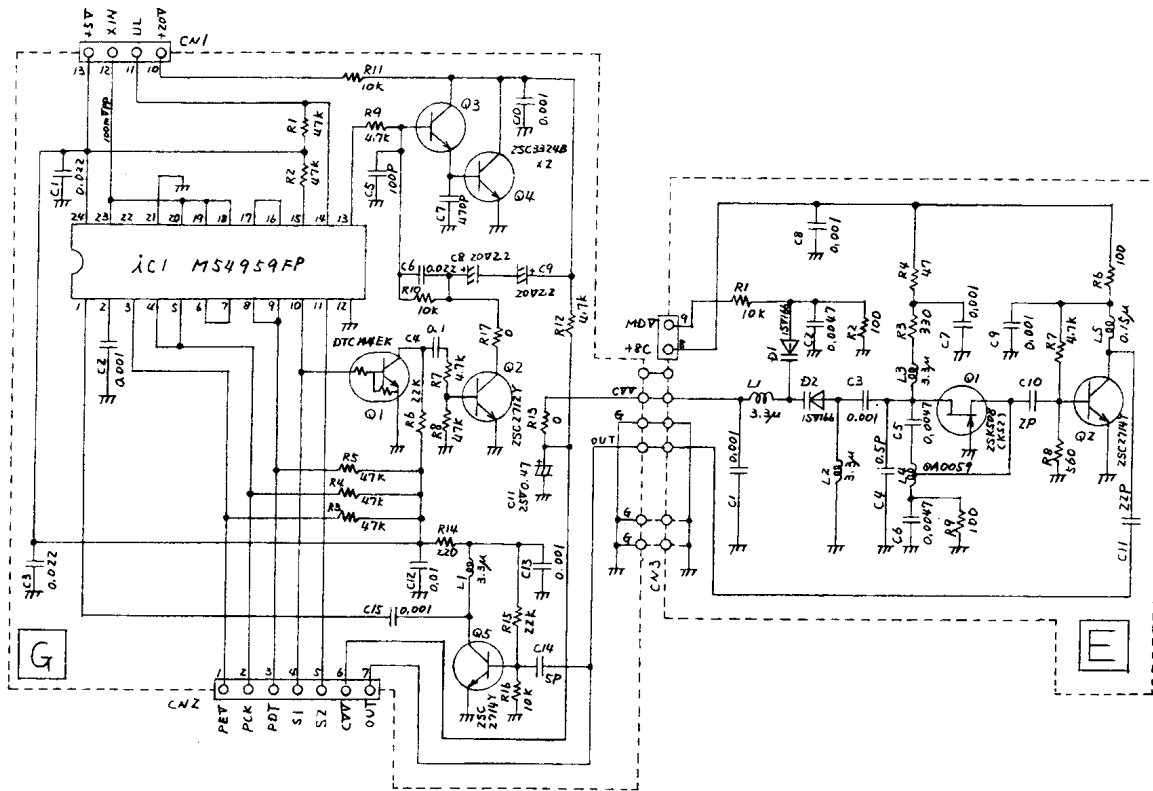

■ VHF PLL, VCO PC BOARD

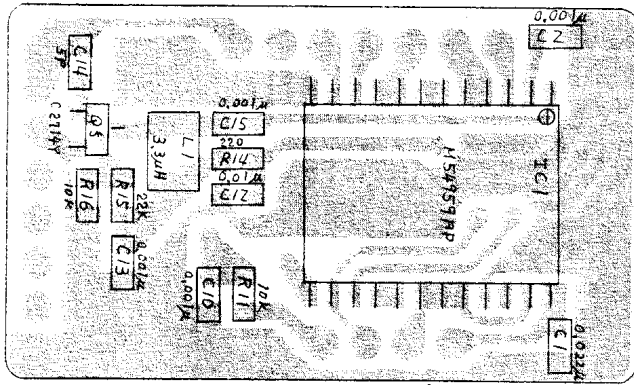

PLL (Part)

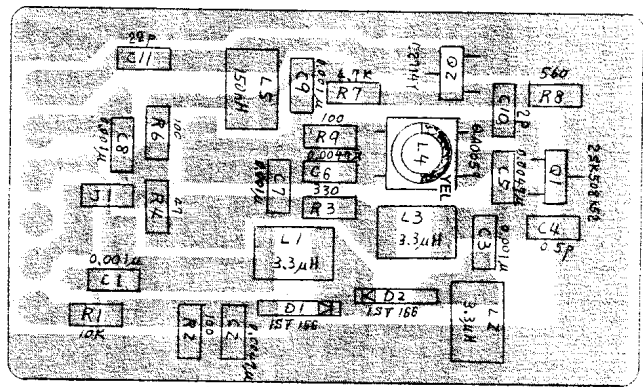

VCO (Part)

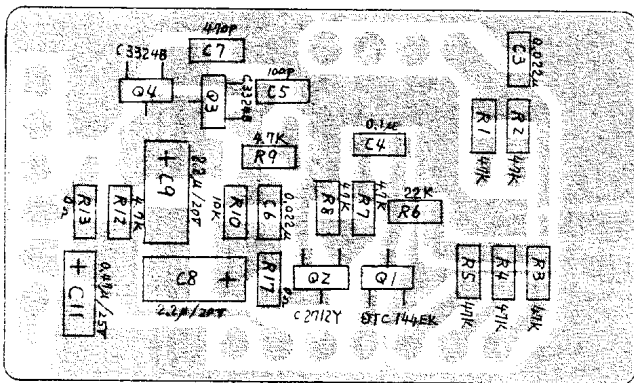

PLL (Solder)

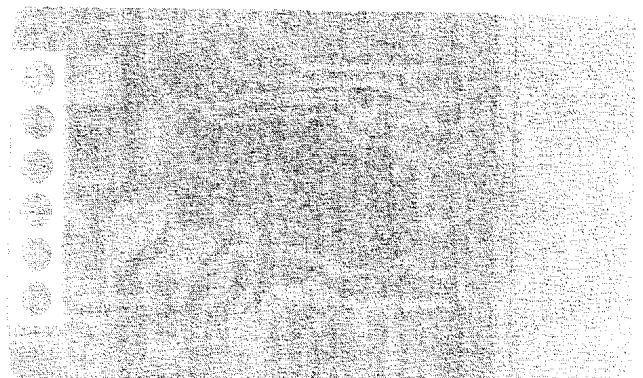

VCO (Solder)

UHF PLL, VCO SCHEMATIC DIAGRAM

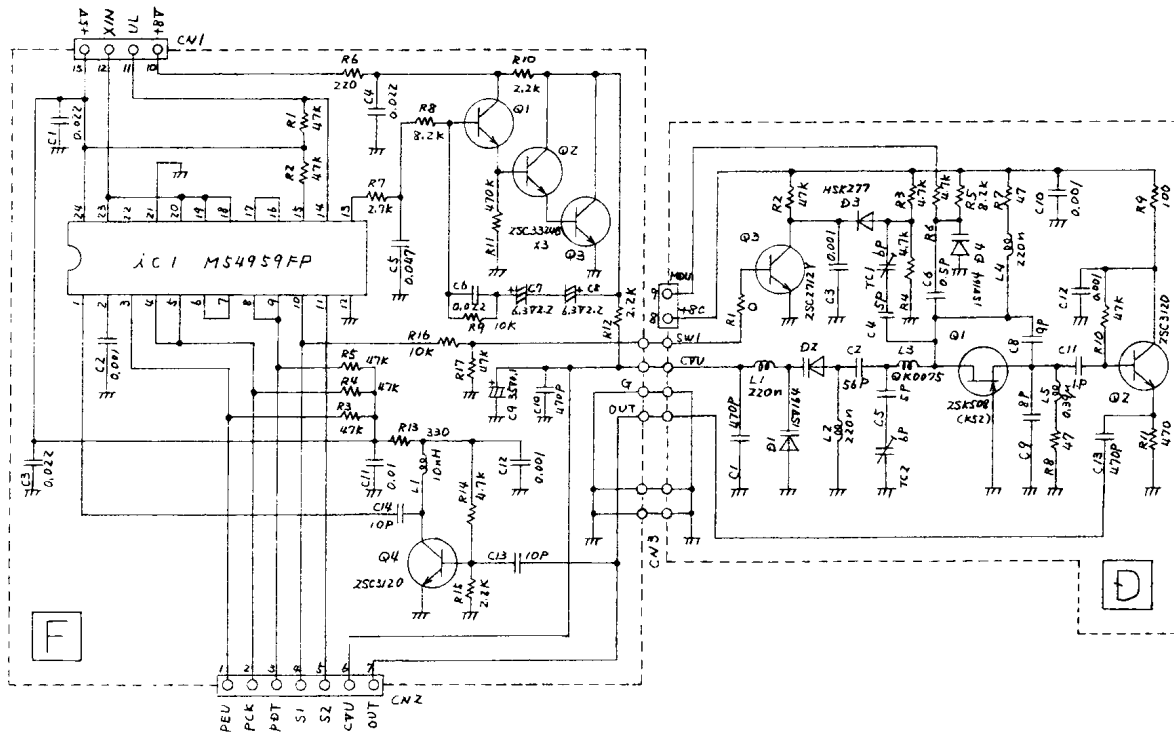

UHF PLL, VCO PC BOARD

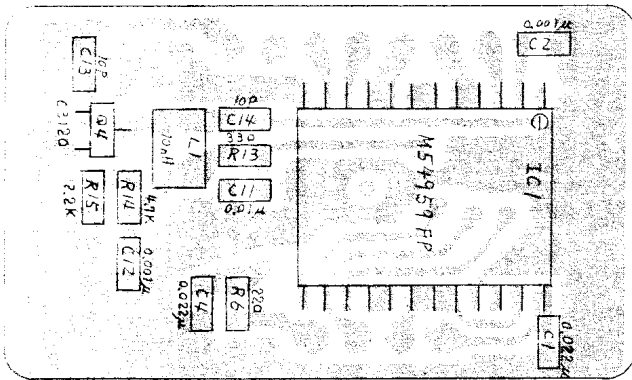

PLL (Part)

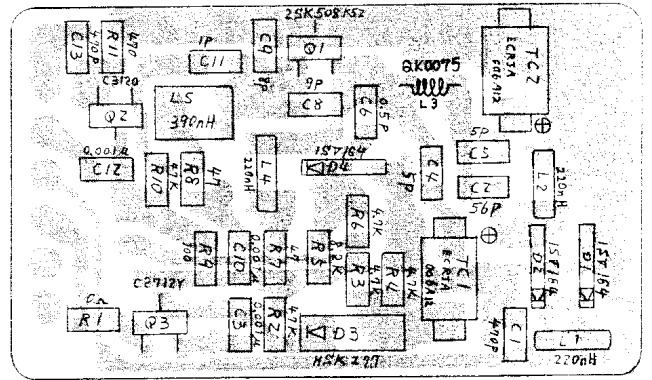

VCO (Part)

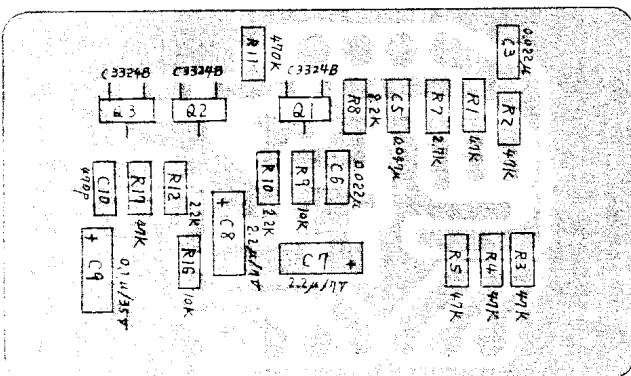

PLL (Solder)

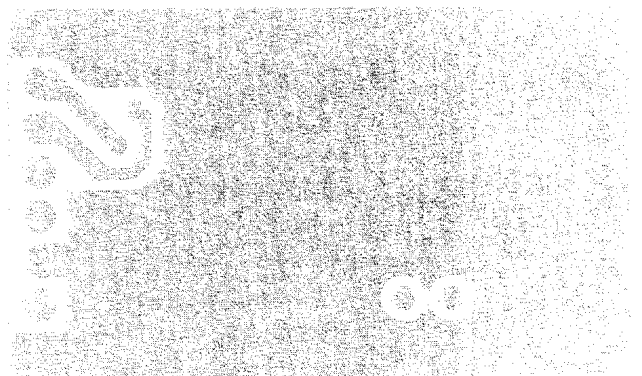

VCO (Solder)

UHF PLL, VCO SCHEMATIC DIAGRAM

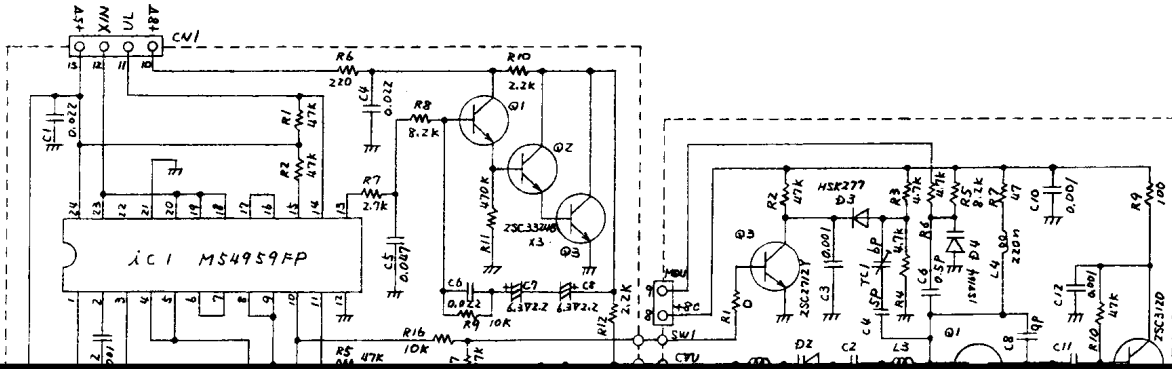

■ VOL PC BOARD

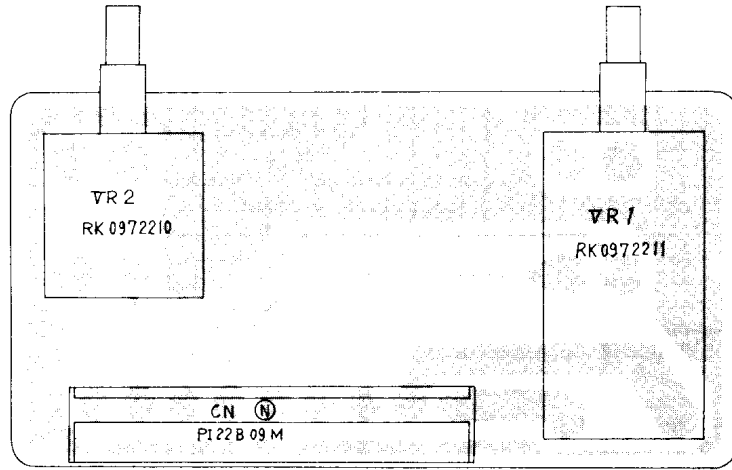

■ POWER SUPPLY PC BOARD

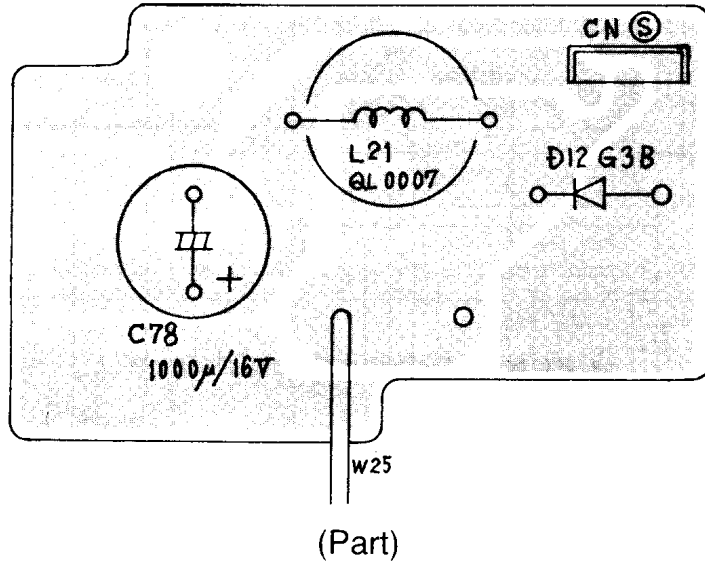

(Part)

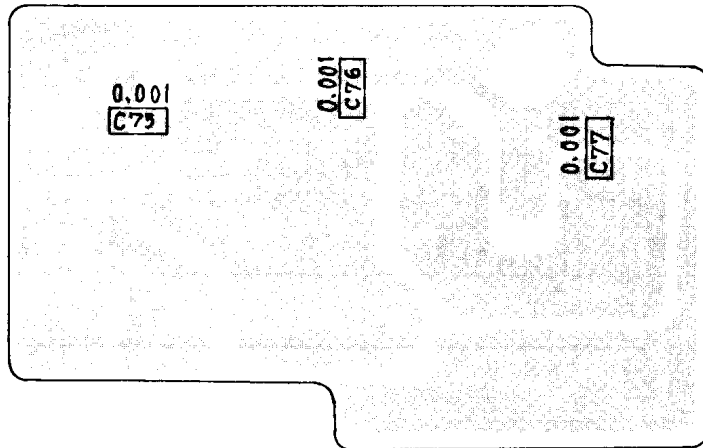

(Solder)

■ CPU SCHEMATIC DIAGRAM

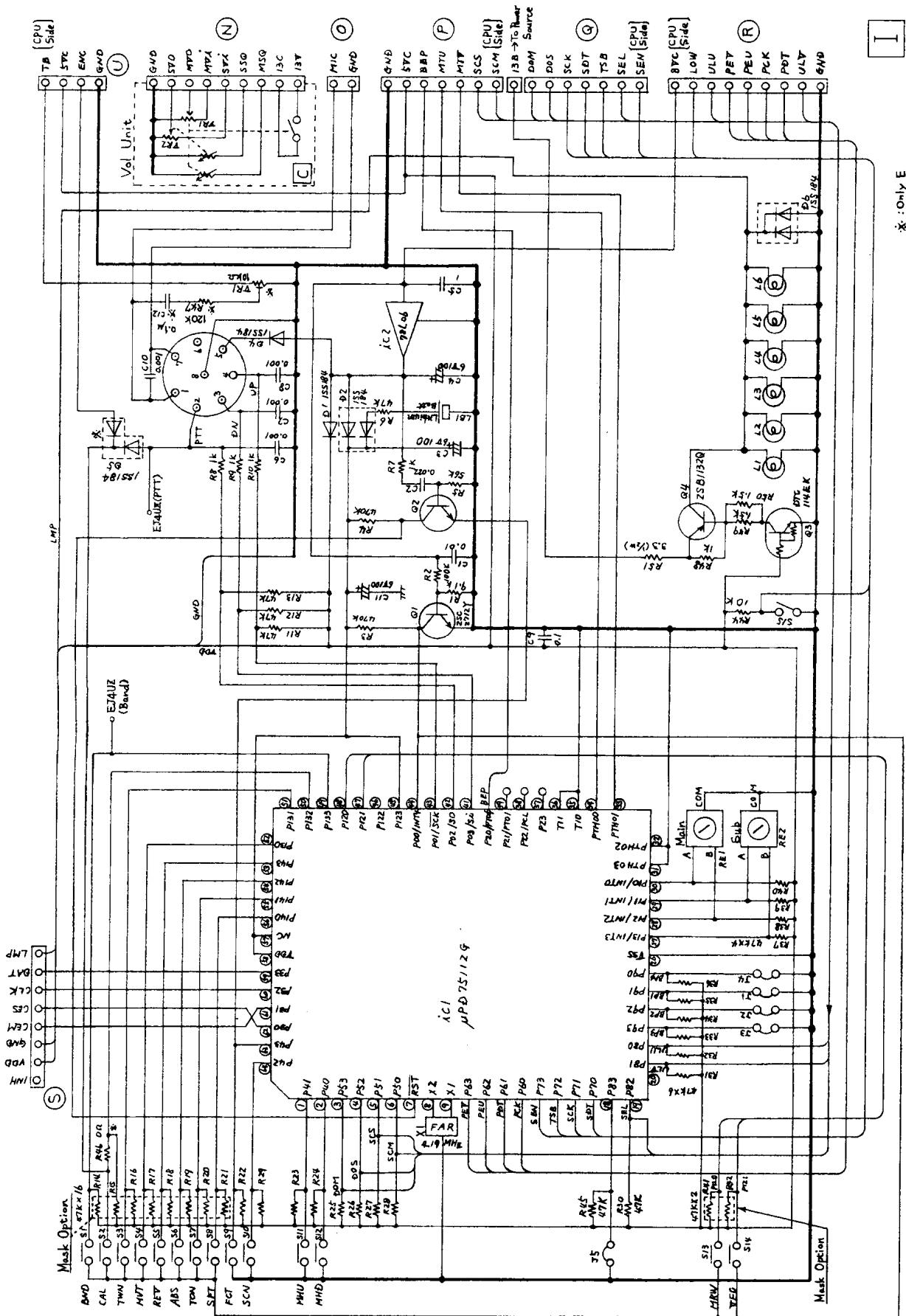

Connection of Unused Terminals

Part	1/2	1/3	1/4	1/5
P21/P20	0	L		
P12/P11	0	L		
P23	0	L		
PTH02	A	L		
PTH03	A	L		
T11	A	L		
T10	A	L		
P122	A	H		
P123	A	H		

Mark

Mark	1/2	1/3	1/4	1/5
R46	X			
R47	X			
C12	X			
D5	X			
T1	X			

■ CPU PC BOARD

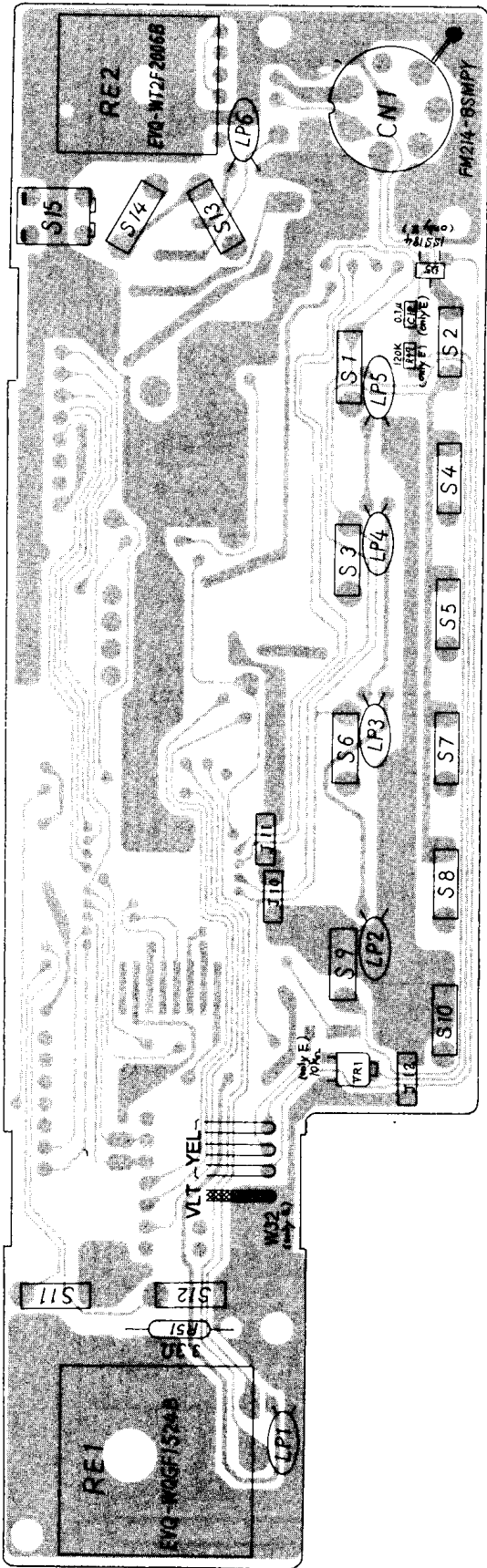

(Part)

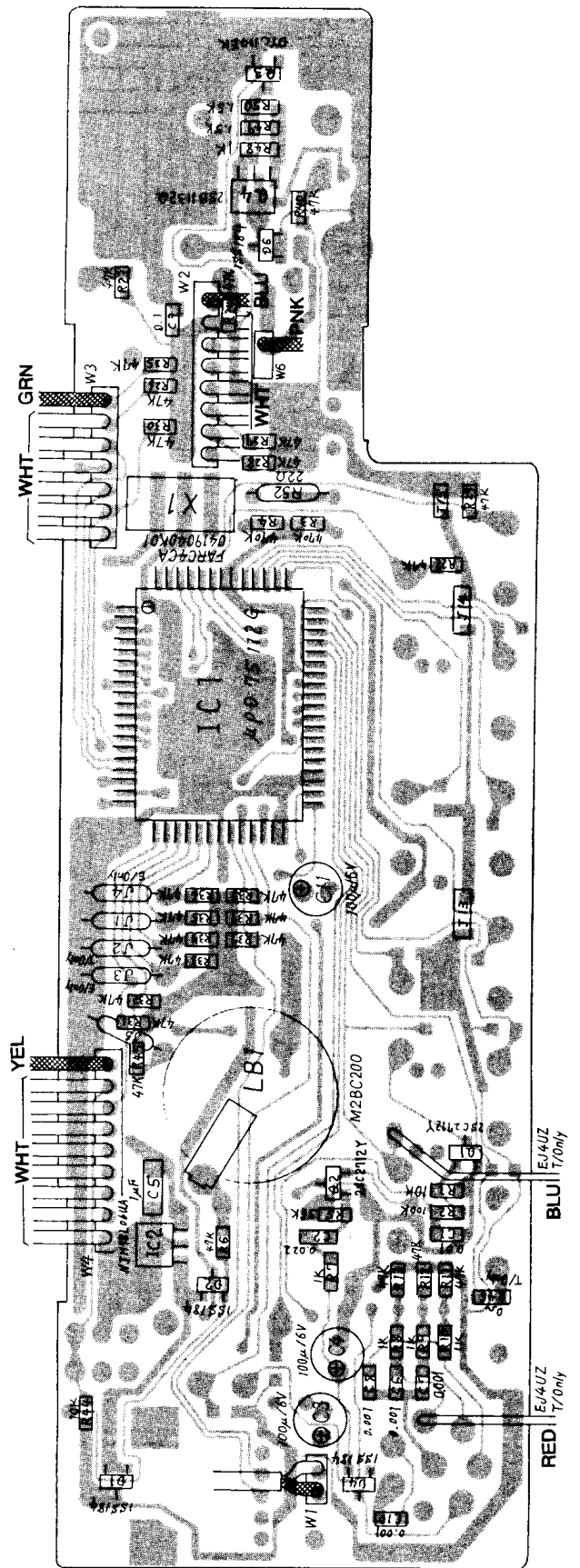

(Solder)

■ CPU PC BOARD

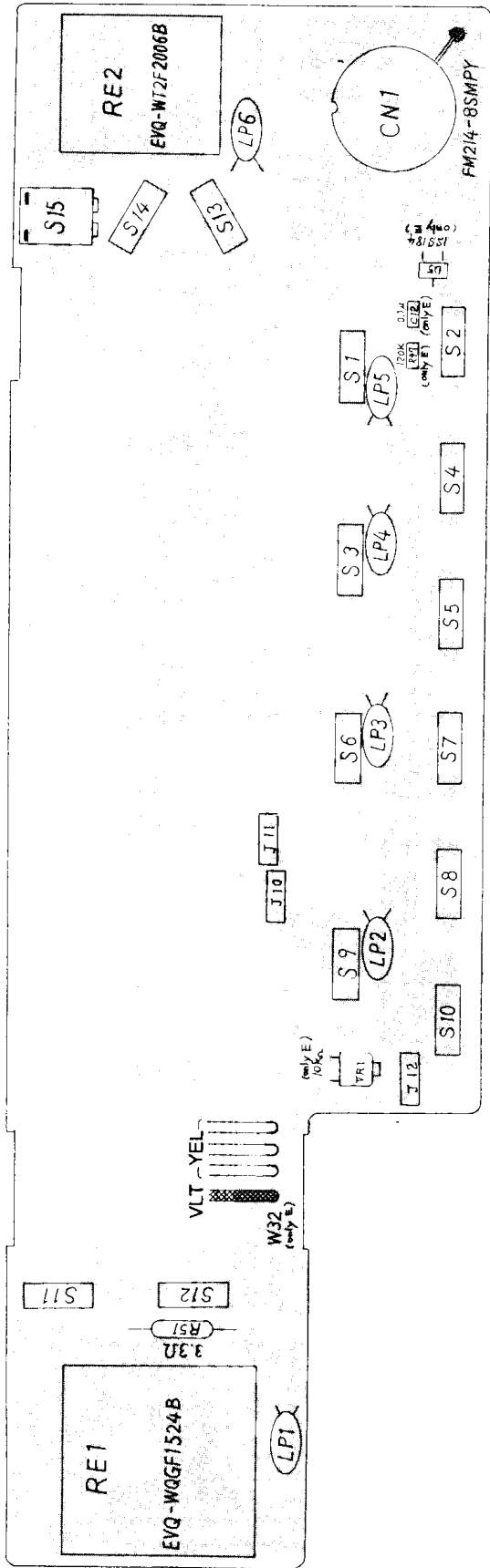

(Part)

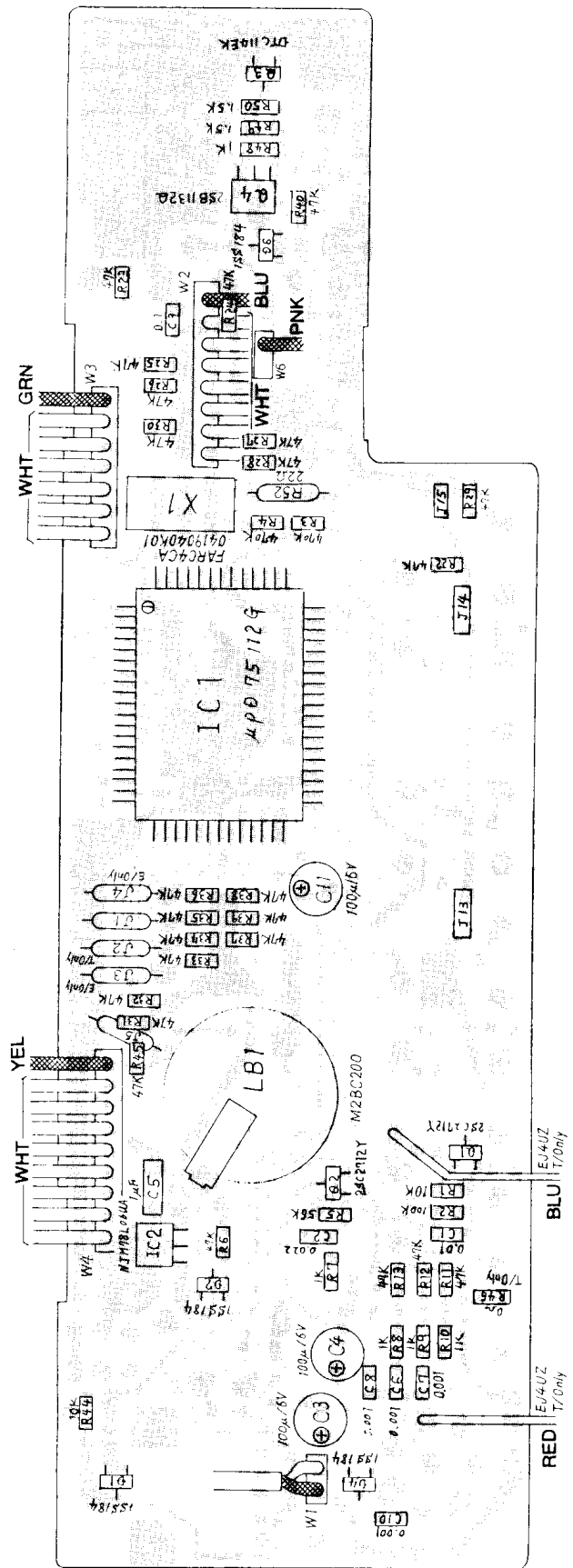

(Solder)

CONTROL SCHEMATIC DIAGRAM

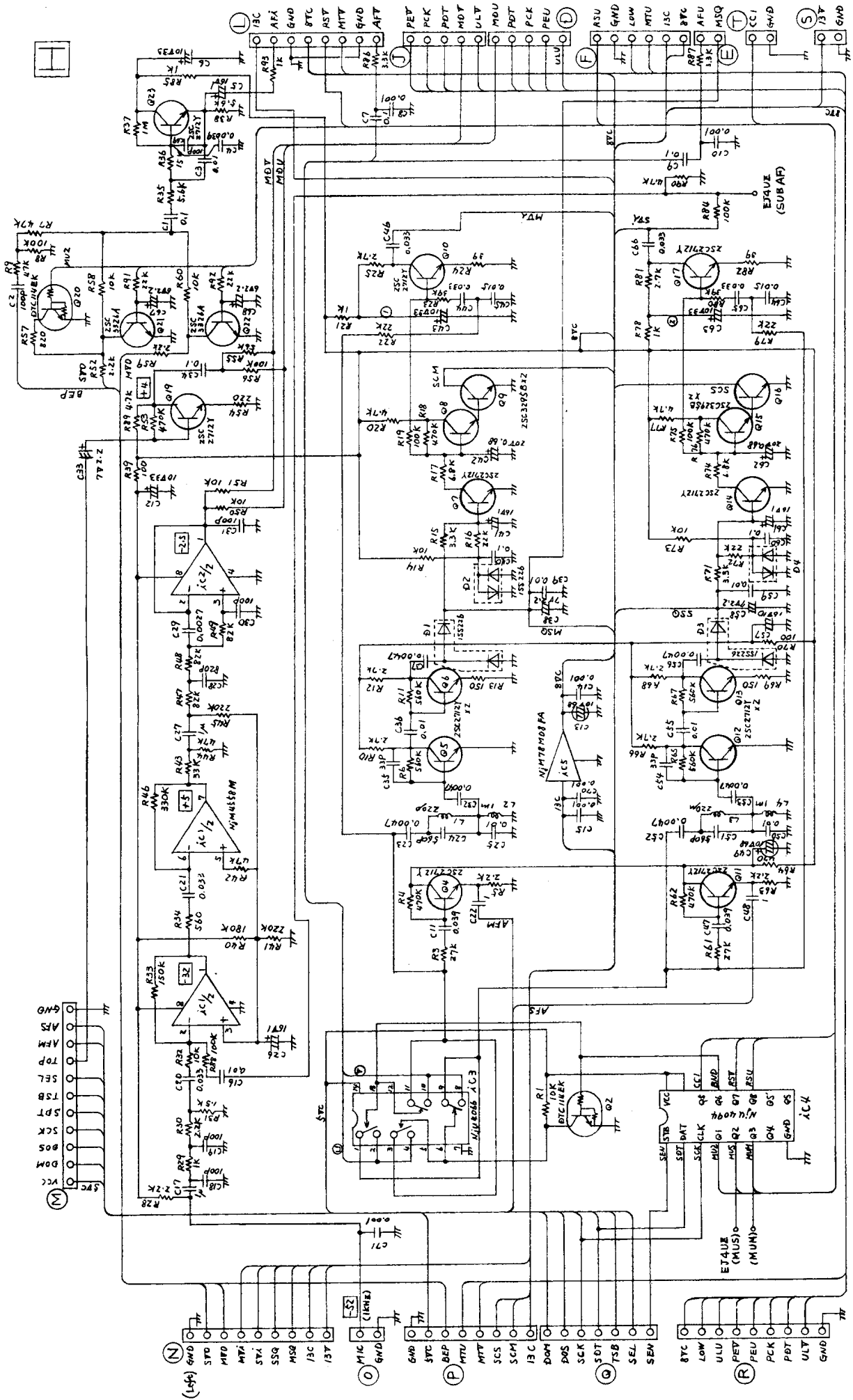

X'CON SCHEMATIC DIAGRAM

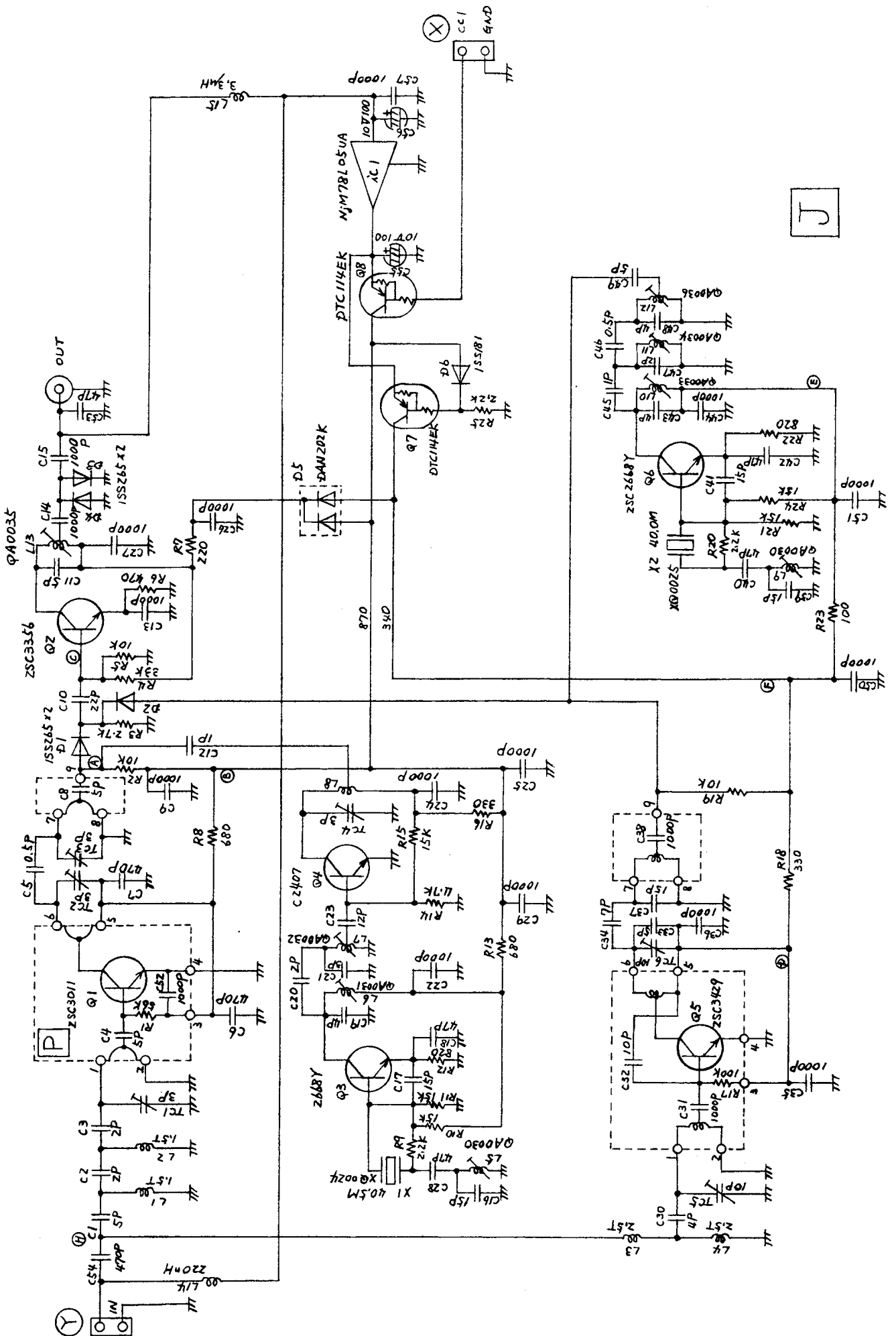

■ X'CON PC BOARD

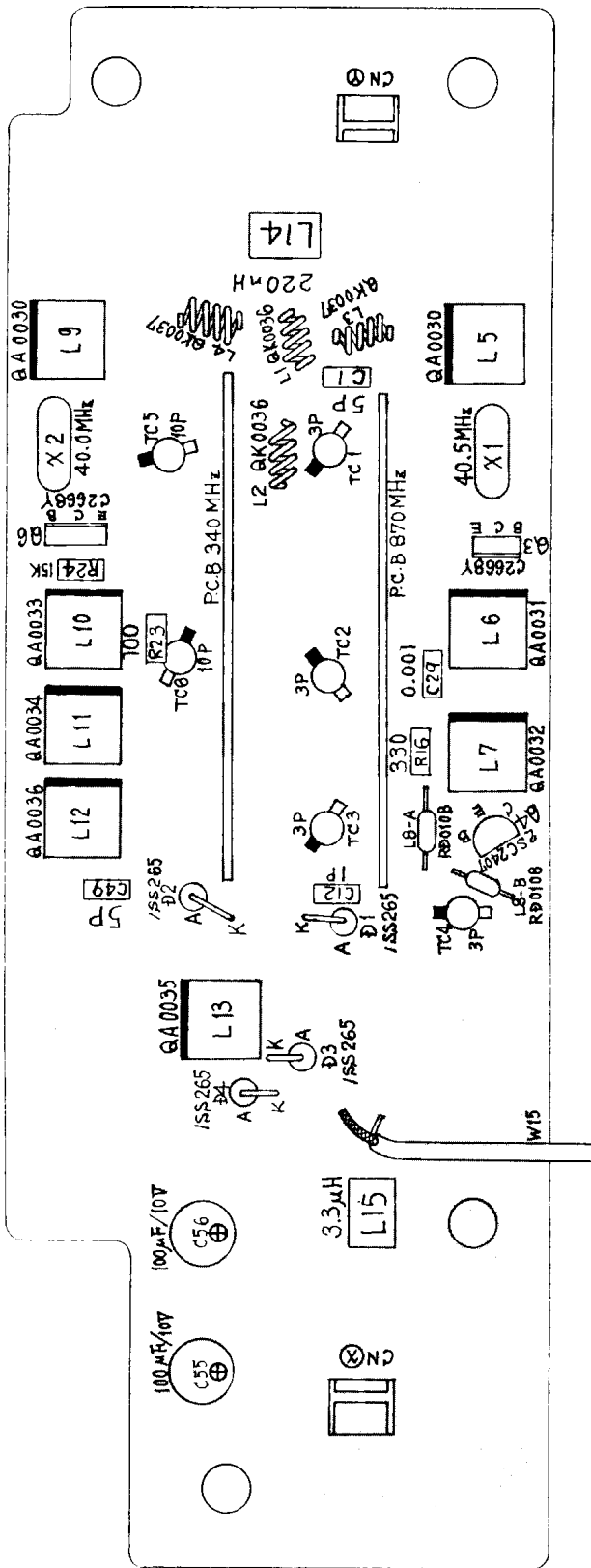

(Part)

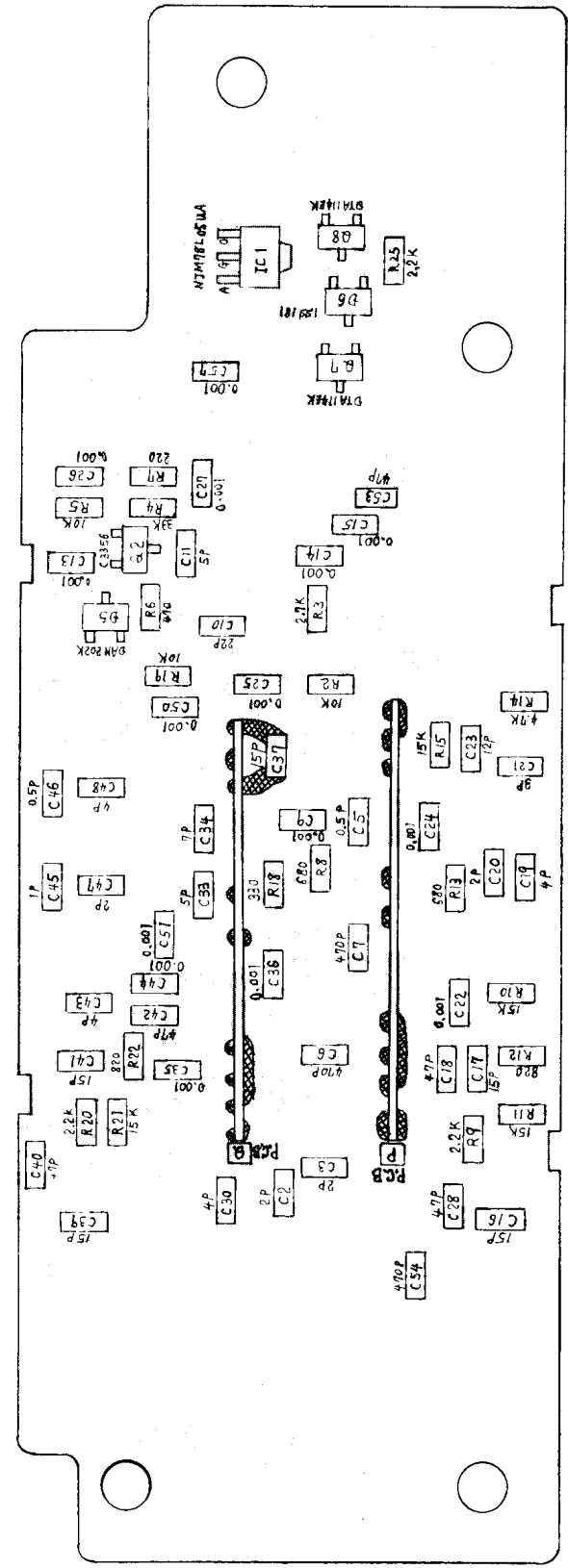

(Solder)

■ X'CON PC BOARD

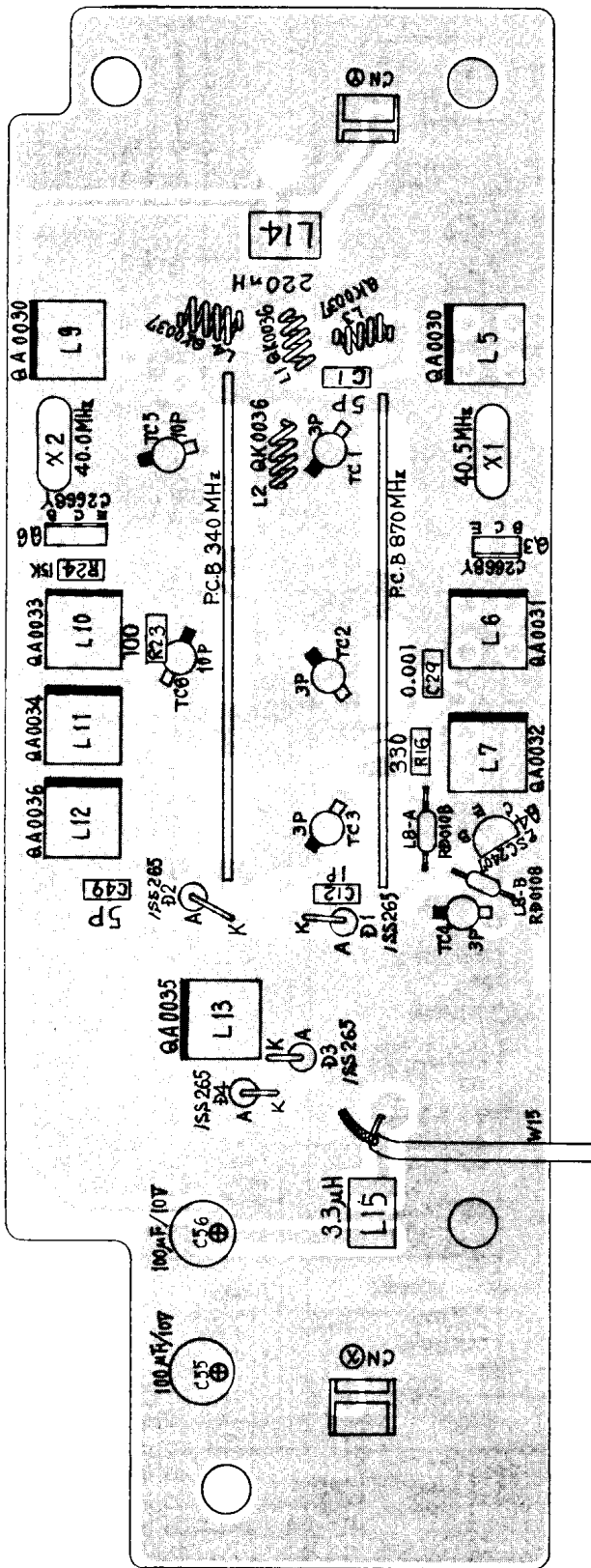

(Part)

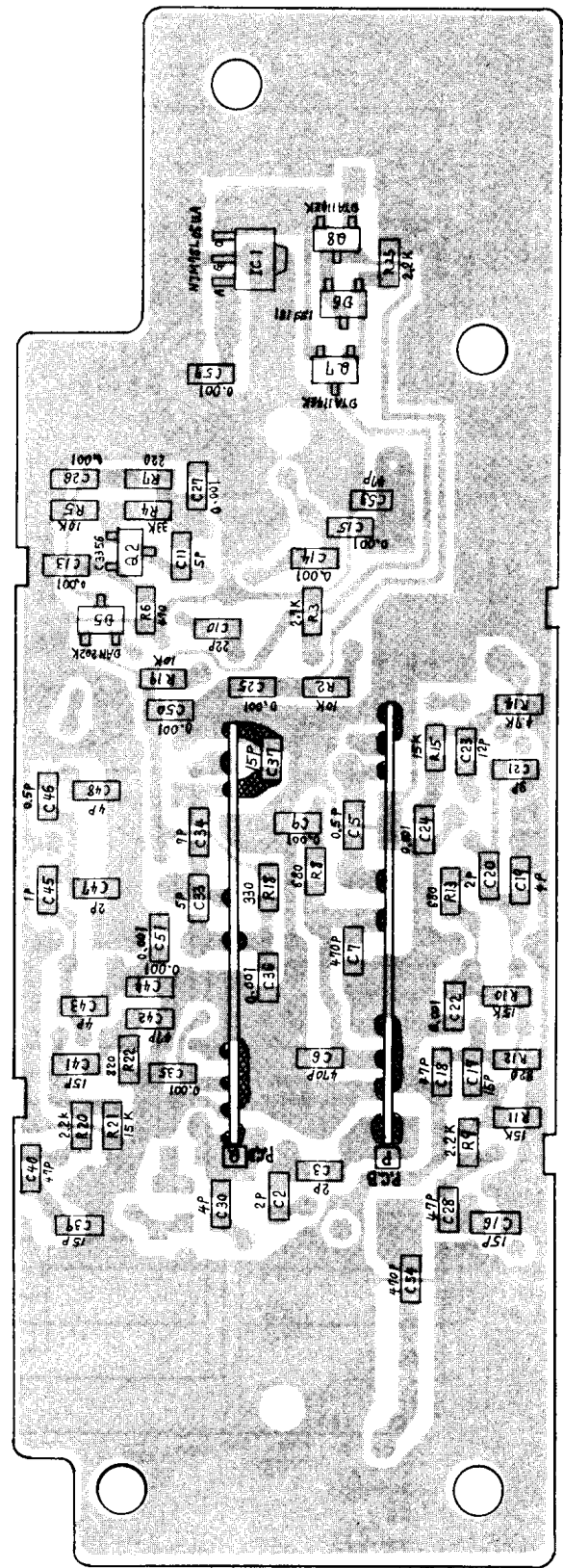

(Solder)

FINAL, DUPLEXER SCHEMATIC DIAGRAM

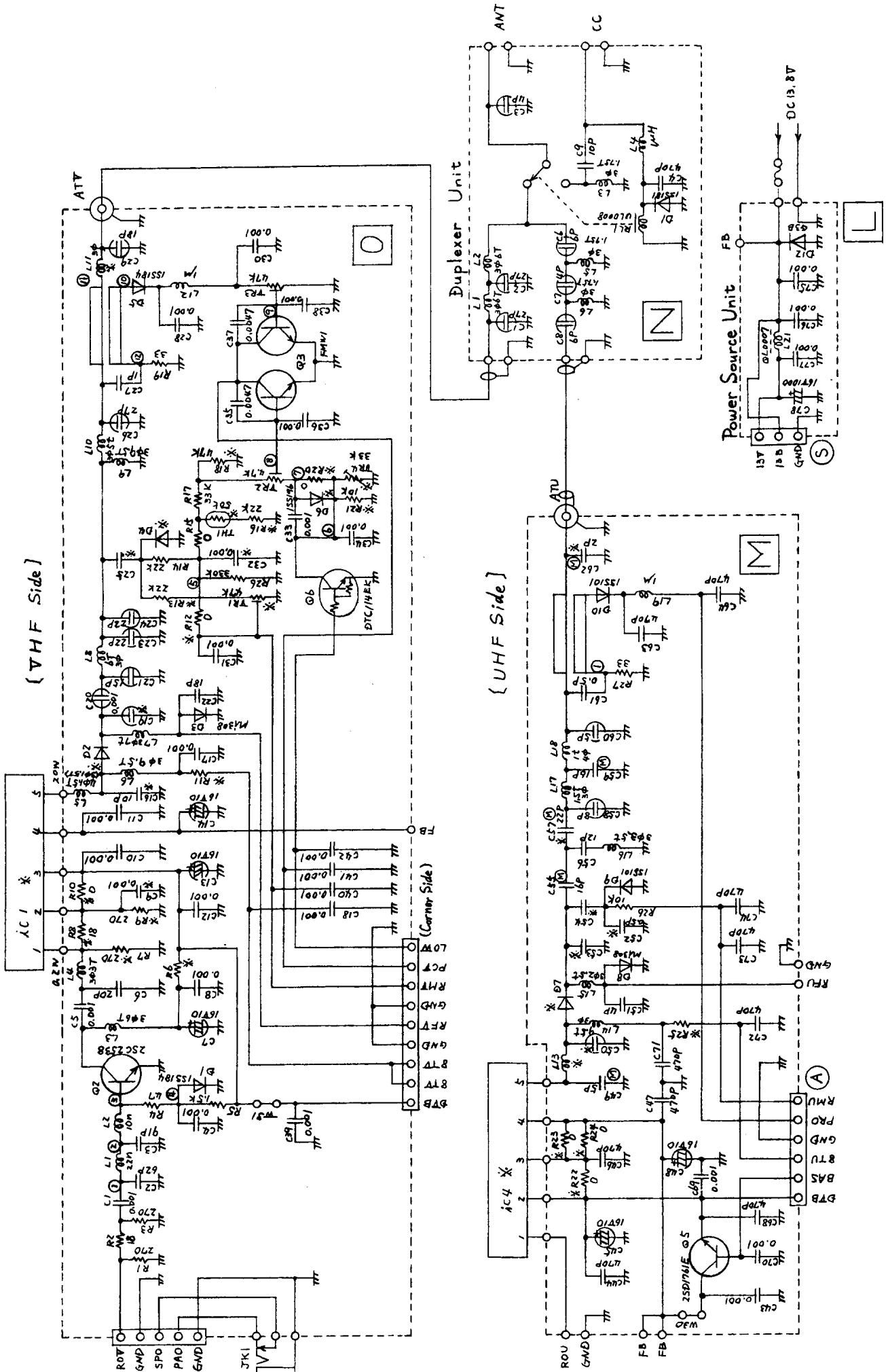

< : T

■ VHF FINAL PC BOARD

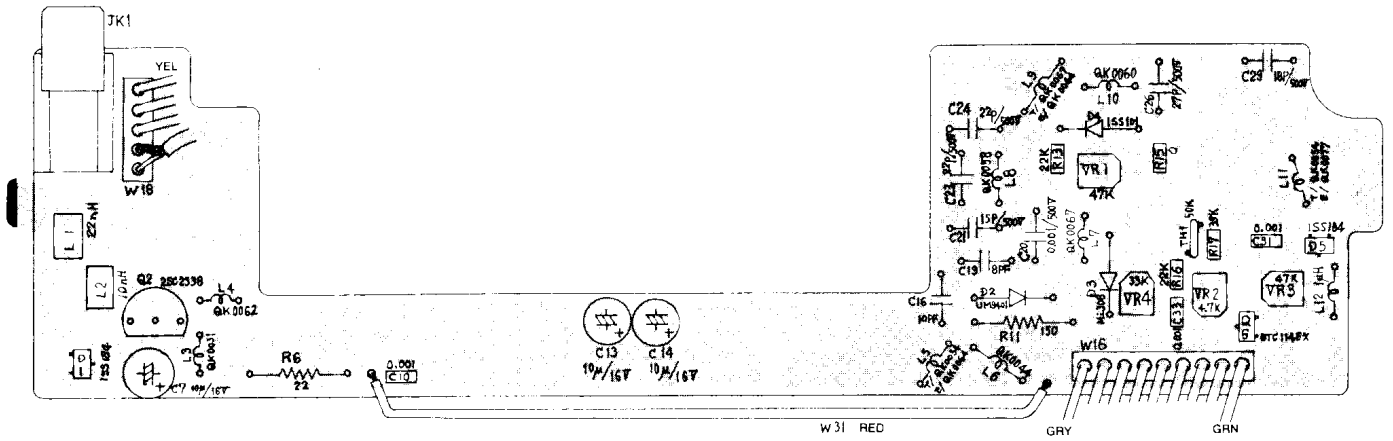

(Part)

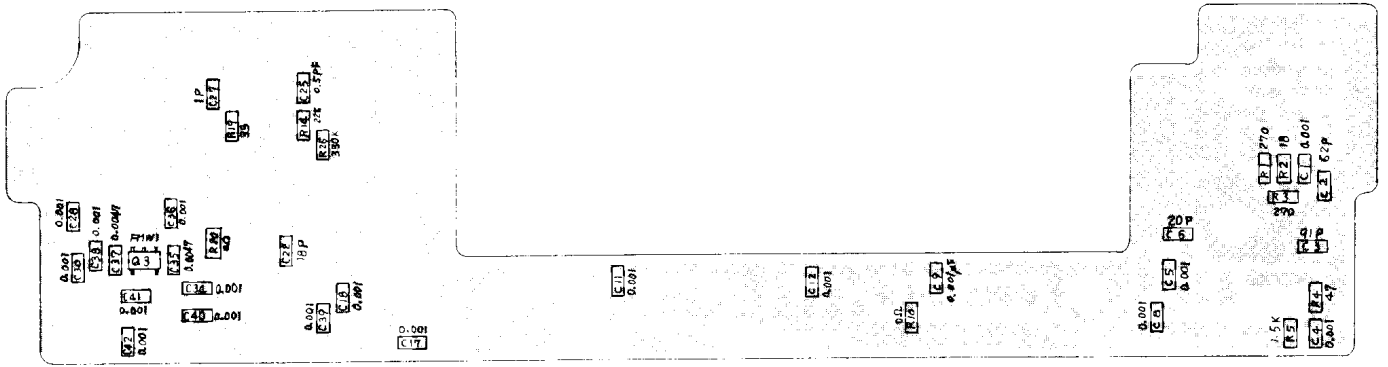

(Solder)

■ UHF FINAL PC BOARD

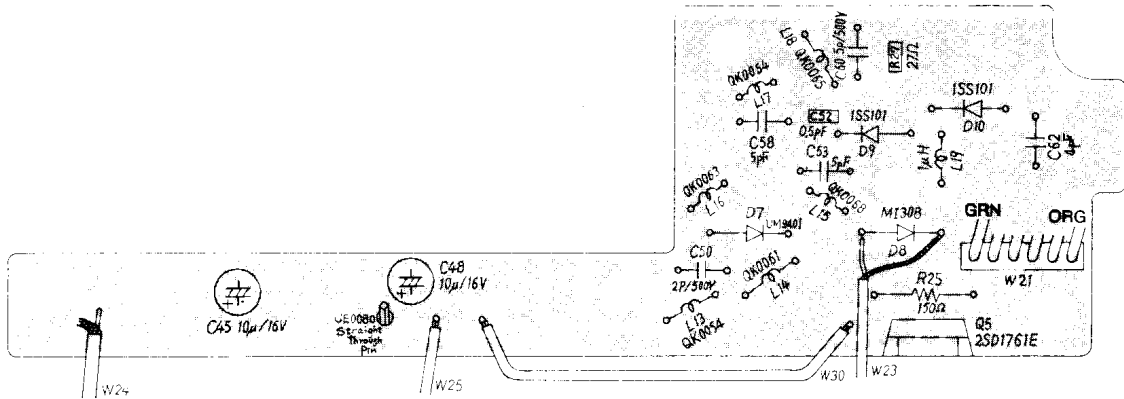

(Part)

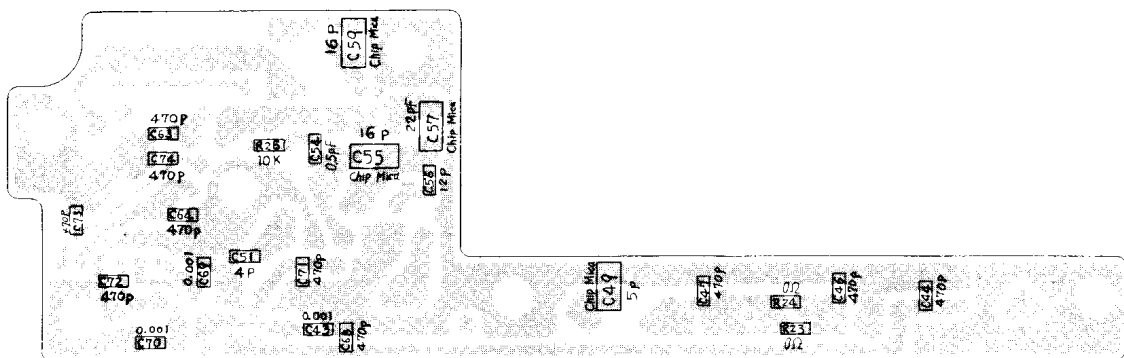

(Solder)

■ VHF FINAL PC BOARD

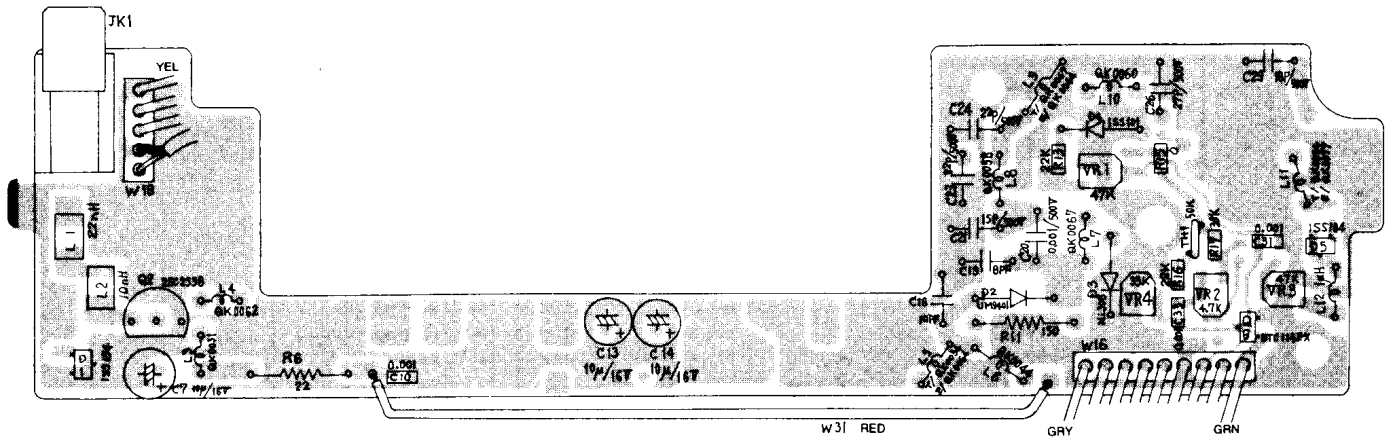

(Part)

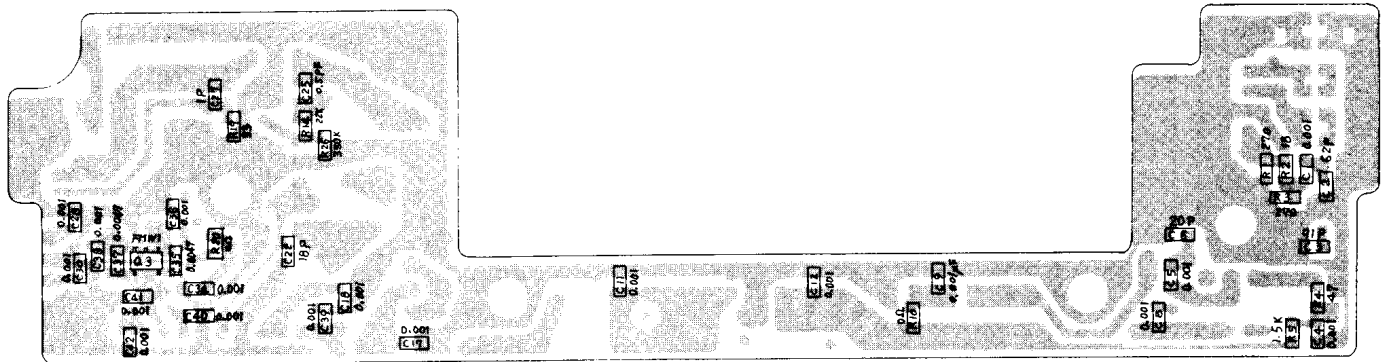

(Solder)

■ UHF FINAL PC BOARD

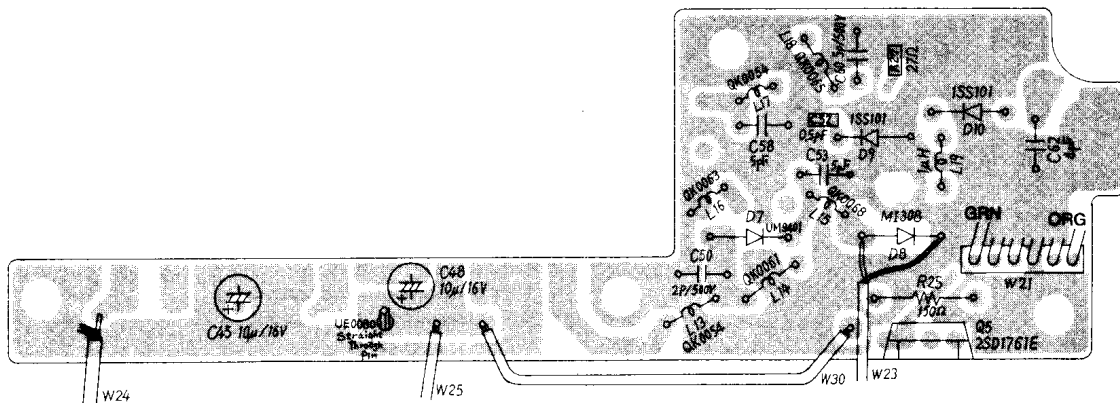

(Part)

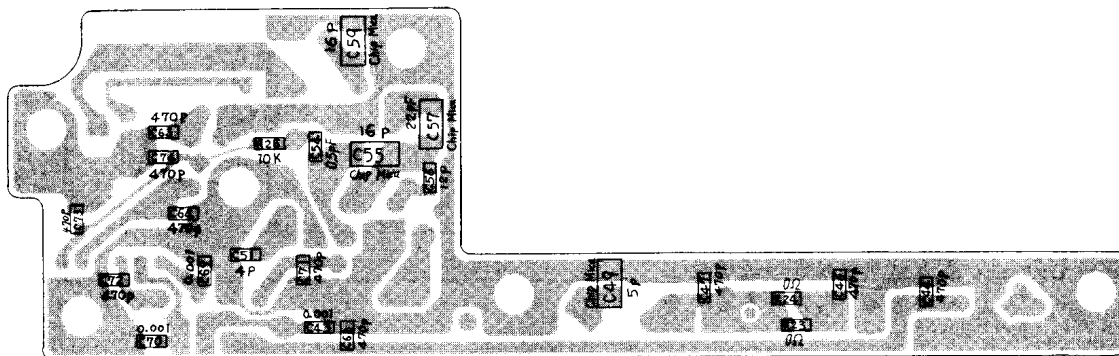

(Solder)

■ CTCSS PC BOARD (T only)

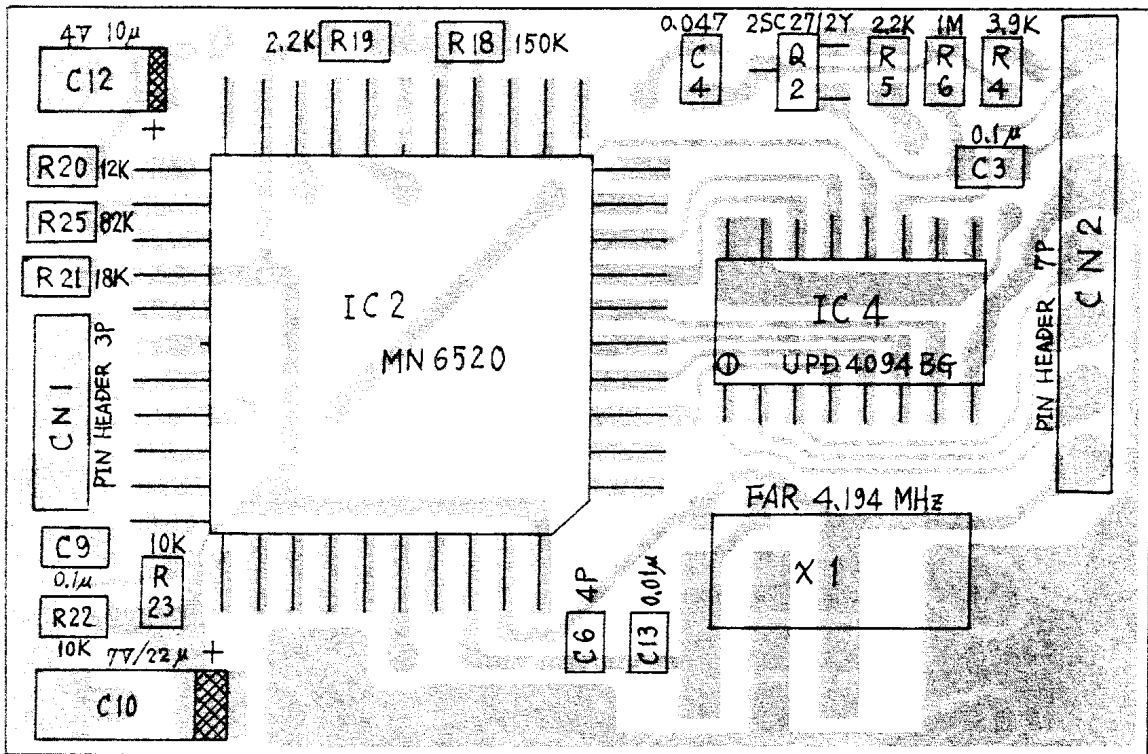

(Main)

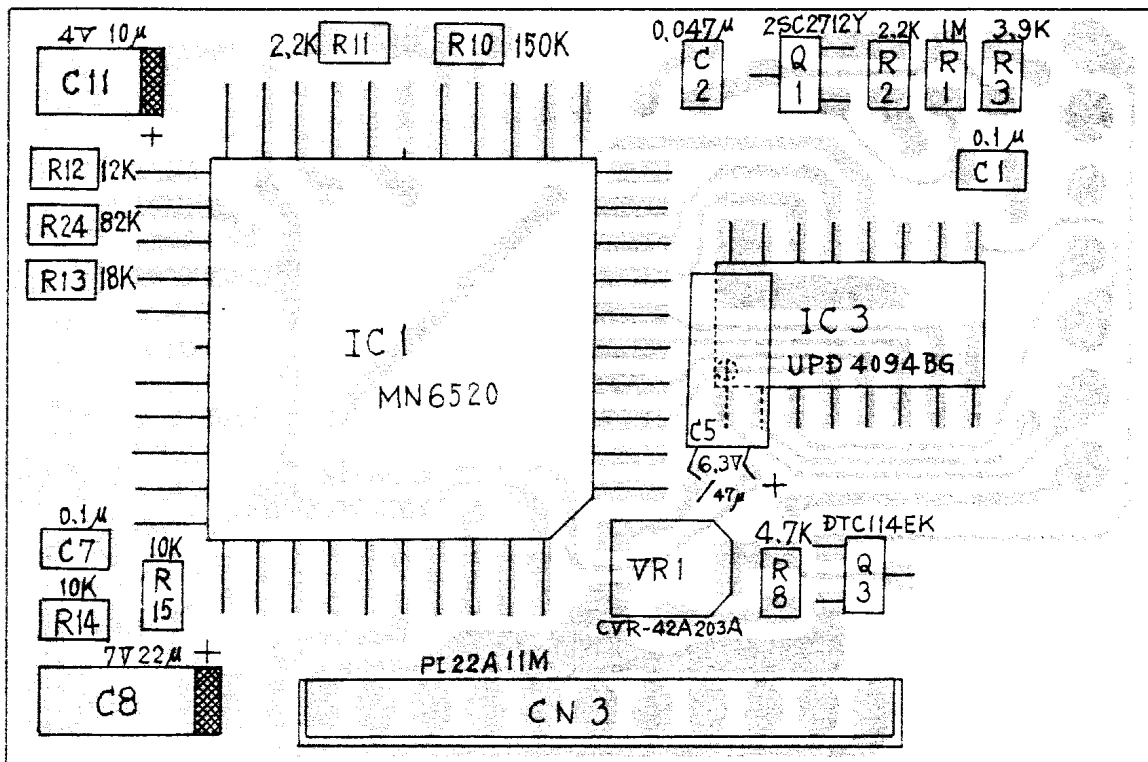

(Sub)

■ DUPLEXER PC BOARD

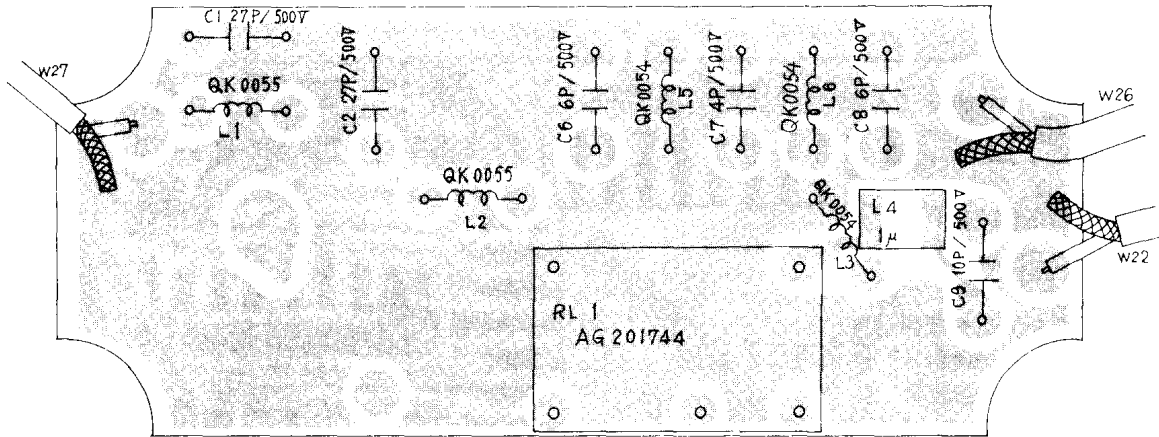

(Part)

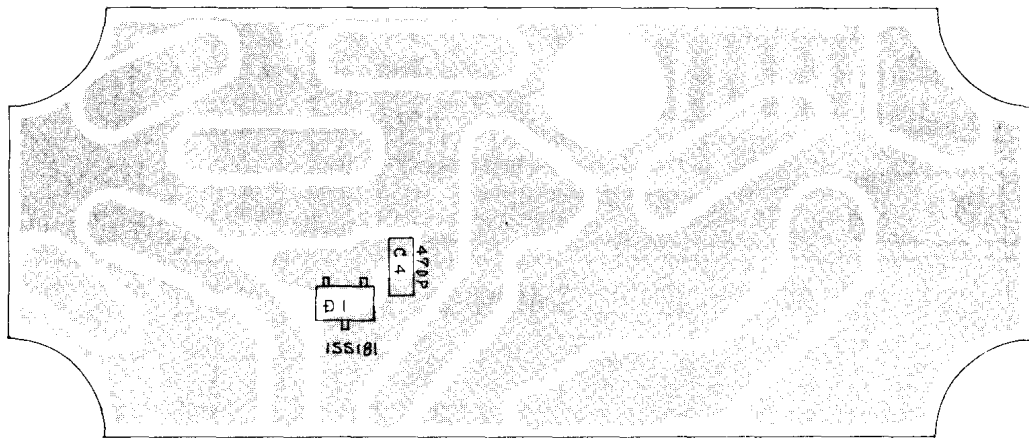

(Solder)

■ TONE SQUELCH SCHEMATIC DIAGRAM

